



ONE WATER LA 2040 PLAN

VOLUME 1

Summary Report

FINAL DRAFT | APRIL 2018



CITY OF LOS ANGELES

ONE WATER LA 2040 PLAN

VOLUME 1 Summary Report

FINAL DRAFT • APRIL 2018

This document is released for the purpose of information exchange review and planning only under the authority of Inge Wiersema • April 30, 2018
State of California • PE License No. 66123



IN COLLABORATION WITH:



1.1 SUMMARY OF ONE WATER LA

The One Water LA 2040 Plan (Plan) takes a holistic and collaborative approach to consider all of the City's water resources from surface water, groundwater, potable water, wastewater, recycled water, dry-weather runoff, and stormwater as "One Water." Also, the Plan identifies multi-departmental and multi-agency integration opportunities to manage water in a more efficient, cost effective, and sustainable manner. The Plan represents the City's continued and improved commitment to proactively manage all its water resources and implement innovative solutions, driven by the Sustainable City pLAn. The Plan will help guide strategic decisions for integrated water projects, programs, and policies within the City.



1.2 PLAN ORGANIZATION

The One Water LA 2040 Plan consists of ten volumes:

- VOLUME 1 - Summary Report
- VOLUME 2 - Wastewater Facilities Plan
- VOLUME 3 - Stormwater & Urban Runoff Facilities Plan
- VOLUME 4 - LA River Flow Study
- VOLUME 5 - Integration Opportunities Analysis Details
- VOLUME 6 - Climate Risk & Resilience Assessment for Wastewater & Stormwater Infrastructure
- VOLUME 7 - Implementation Strategy Supporting Documents
- VOLUME 8 - Technical Support Materials
- VOLUME 9 - Stakeholder Engagement Materials
- VOLUME 10 - Programmatic Environmental Impact Report

The information presented in this Summary Report (Volume 1) represents a summary of the Plan.

1.3 VOLUME 1 OVERVIEW & ORGANIZATION

An overview of information presented in this volume is provided in the Table below.

Chapter No. and Name		Content Overview
ES	Executive Summary	Executive summary of the entire volume that focuses on key findings, conclusions, and recommendations/strategies.
1	Introduction	Provides an introduction to the Plan and Summary Report.
2	Plan Collaboration and Stakeholder Engagement	Describes collaboration and stakeholder engagement that took place during development of the One Water LA 2040 Plan.
3	Existing Water Management Strategies	Summarizes existing water management strategies. A discussion of the current water management challenges and an overview of the City's existing water supplies and water supply goals are provided, with each water supply strategy discussed in more detail. In sequential order, this includes descriptions of the City's current programs in water conservation programs, local groundwater, recycled water, stormwater, and the Los Angeles River.
4	Flows and Demands	Presents existing projects flows and demands for each of the City's water sources.
5	Current Integration Opportunities	Presents the current integration project opportunities that were identified as part of the One Water LA 2040 Plan development. Current integration opportunities are existing and/or planned projects that have or could include a water management component and that require collaboration of multiple City departments and/or regional agencies.
6	Future Integration Opportunities	Presents the future integration opportunities that were identified as part of the One Water LA 2040 Plan development. Future integration opportunities are a mix of projects and programs called "concept options" that support the One Water LA objectives, the Sustainable City pLAN goals, and the supply strategy defined in the 2015 Urban Water Management Plan.
7	Wastewater Facilities Plan	Provides a summary of the Wastewater Facilities Plan (provided in Volume 2).
8	Stormwater and Urban Runoff Facilities Plan	Provides a summary of the Stormwater and Urban Runoff Facilities Plan (Provided in Volume 3).

Chapter No. and Name	Content Overview
<p>9 Plan Recommendations and Implementation Strategy</p>	<p>Presents and summarizes the One Water LA 2040 Plan recommendations, associated timelines, and implementation strategy. Beginning with a description of the categories of Plan recommendations, followed by a discussion of the project timelines and phasing assumptions. Subsequently, the Plan recommendations are presented by category. For each of these categories, phasing assumptions, cost estimates, and a cost summary by phase are discussed. Subsequently, the project timelines summary is presented. The chapter is concluded with the adaptive implementation strategy, which includes a discussion of the wide variety of project triggers that were identified, and used to develop a trigger-based implementation strategy to allow adaptive decision-making as system conditions and needs evolve over time.</p>
<p>10 Funding Needs and Next Steps</p>	<p>Presents the various funding strategies that could be utilized to help finance the recommended projects, programs, and policies presented in the One Water LA 2040 Plan. The chapter concludes with a discussion of the next steps beyond the completion of the Plan.</p>
<p>Appendices</p>	<p>Provides supporting materials including the references, concept option description summaries, wastewater projects, stormwater project database, and policies and programs.</p>

ACKNOWLEDGMENTS

The successful completion of the One Water LA 2040 Plan has been made possible by the significant contribution of the groups and individuals acknowledged below:

LOS ANGELES SANITATION

Executive Management

Enrique Zaldivar Director
Traci Minamide.....Chief Operating Officer
Doug Walters Chief Sustainability Officer
Adel Hagekhalil.....Assistant Director
Pam Perez.....Marketing Manager

Wastewater Engineering Services Division

Ali Poosti Division Manager
Lenise Marrero One Water LA Project Manager & Assistant Division Manager
Regidia Voong.....Assistant Project Manager
Azya Jackson..... Assistant Project Mgr., Lead for Stormwater & LA River
Denise Chow..... Task Lead for Wastewater Facilities Plan & Rancho Park Study
Flor BurrolaCo-Lead Policies and Co-Lead Current Integration Opportunities
Troy Ezeh..... One Water LA Team member
Ani Abassian One Water LA Team member
Aron Sordan One Water LA Team member
Andre Goodridge..... One Water LA Team Member
Rafael Rincon One Water LA Team member
Cesar Cortes One Water LA Team member
Manik Mohandas Wastewater Conveyance Analysis
Rowena Lau (former) Wastewater Conveyance Analysis
Oscar Figueroa GIS Lead
Tim Chen..... One Water LA Team member
Rebecca Drayse.....Task Lead Policies and Stakeholder Engagement
Eliza Jane Whitman Task Lead Climate Resilience and Funding;
Co-lead Stormwater and Wastewater Facilities Plan

Watershed Protection Division

Shahram Kharaghani Division Manager
 Wing Tam Assistant Division Manager
 Hubertus Cox Assistant Division Manager
 Alfredo Magallanes Assistant Division Manager
 Deborah Deets Landscape Architect
 Stefanie Perez One Water LA Team member
 Jane Parathara One Water LA Team member
 Steve Nikaido..... One Water LA Team member
 Ryan Thiha One Water LA Team member
 Susie Santilena One Water LA Team member

Water Reclamation

Timeyin Dafeta..... Hyperion WRP Plant Manager
 Shahrouzeh SaneieHyperion WRP Environmental Engineer
 Roshanak Aflaki..... Donald C. Tillman and LA-Glendale WRPs Plant Manager
 Joline Munoz.....Donald C. Tillman and LA-Glendale WRPs Environmental Engineer
 Mark Starr Terminal Island WRP Plant Manager
 Nasir EmamiHyperion WRP Environmental Engineer Associate

LOS ANGELES DEPARTMENT OF WATER & POWER

Executive Management

Martin Adams Chief Operating Officer
 Richard Harasick Senior Assistant General Manager

Water Resources Division

David Pettijohn Director
 Evelyn Cortez-DavisAssistant Director
 Penny Falcon One Water LA Project Manager & Water Resources Policy Manager
 Serge Haddad Assistant Project Manager & WETS Construction Mgmt. Group Manager
 Anthony Tew.....One Water LA Project Lead
 Bob Sun.....One Water LA Project Lead
 Christine Tran One Water LA Team member
 Darline Truong One Water LA Team member
 Rafael Villegas One Water LA Team member
 Arturo Castro..... One Water LA Team member
 Jevon Lam One Water LA Team member

Delon Kwan One Water LA Team member
Simon Hsu One Water LA Team member
Kimberly Ohara One Water LA Team member
Gregory Reed One Water LA Team member
Christopher Repp One Water LA Team member
Austin Straus One Water LA Team member
Virginia Wei One Water LA Team member
Scott Hungerford One Water LA Team member
Anthony Nercessian One Water LA Team member

Water Engineering and Technical Services Division

William Van Wagoner Assistant Director
Mario Acevedo One Water LA Team member
George Zordilla One Water LA Team member
Amy Lee Webb One Water LA Team member
Yoshiko Tsunehara One Water LA Team member
Terry Nguyen One Water LA Team member

Water Executive Office

Julie Spacht One Water LA Team member

Community Relations Office

Stephanie Spicer One Water LA Team member

LOS ANGELES BUREAU OF ENGINEERING

Kenneth Redd Deputy City Engineer
Alfred Mata Deputy City Engineer
Michael Sarullo Environmental Engineering Services Division Engineer
Susan Shu Street Improvement and Stormwater Senior Engineer
Slavica Hammond Environmental Engineering Services Division Consultant

MAYOR'S OFFICE

Eric Garcetti Mayor of Los Angeles
Liz Crosson Director of Infrastructure at Office of Mayor Eric Garcetti
Michael Affeldt Director of LARiverWorks at Office of Mayor Eric Garcetti

ONE WATER LA ADVISORY GROUP

Brad Cox..... Los Angeles Business Council
 Carolyn CassavanSherman Oaks Neighborhood Council
 David Nahai David Nahai Companies
 Jack Humphreville Greater Wilshire Neighborhood Council
 Kelly Sanders.....University of Southern California
 Ken Murray, MD Wilderness Corps
 Louise McCarthy.....Community Clinic Association of Los Angeles County
 Melanie Winter The River Project
 Mike O'Gara Sun Valley Area Neighborhood Council
 Veronica Padilla.....Pacoima Beautiful

ONE WATER LA STEERING COMMITTEE & REGIONAL PARTNERS

Nishith Dhandha..... Bureau of Street Services
 Robert Gutierrez Bureau of Street Services
 Patty Watanabe Caltrans
 Domenico Barbato Department of Building and Safety
 Osama Younan Department of Building and Safety
 Christopher Pina..... Department of City Planning
 Claire Bowin Department of City Planning
 Diana Kitching Department of City Planning
 Erick Lopez..... Department of City Planning
 Jonathan Hershey..... Department of City Planning
 Michelle Levy Department of City Planning
 Tom Rothmann..... Department of City Planning
 Stephen Box Department of Neighborhood Empowerment
 Tom Gibson..... Department of Recreation and Parks
 David Somers Department of Transportation
 Tomas Carranza Department of Transportation
 Michael Salumon..... General Services Department
 Karl Fielding..... High Speed Rail
 Meg Cederoth High Speed Rail
 Michelle Boehm..... High Speed Rail
 Angela George Los Angeles County
 Daniel Bradbury..... Los Angeles County
 Cris Liban Los Angeles County Metropolitan Transportation Authority

Jacob Lieb Los Angeles County Metropolitan Transportation Authority
Julia Salinas Los Angeles County Metropolitan Transportation Authority
Christos Chrysiliou Los Angeles Unified School District
Talal Balaa Los Angeles Unified School District
Jeffery Smith Los Angeles World Airports
Robert Freeman Los Angeles World Airports
Darryl Pon Los Angeles Zoo
Christine Frey Metropolitan Water District of Southern California
Grace Chan Metropolitan Water District of Southern California
Chris Brown Port of Los Angeles
Stephen Patchan Southern California Association of Governments
Ed De Mesa U.S. Army Corps of Engineers

ONE WATER LA SPECIAL TOPIC GROUP STAKEHOLDERS

Alex Paxton	Deborah Bloome	Matthew King
Andy Lipkis	Denny Schneider	Melanie Winter
Anthea Raymond	Ghina Yamout	Meredith McCarthy
Arthur Pugley	Grant Jean	Natalia Gaerlan
Becky Hayat	Guangyu Wang	Nurit Katz
Bonnie Bentzin	Jack Baylis	Rita Kampalath
Bruce Reznik	Jack Humphreville	Ruth Doxee Shawn
Carolyn Casavan	Johanna Dyer	Warren Stephen
Claire Latane	Katie Mika	Groner Steven
Clint Granath	Ken Murray	Johnson Tom
Craig Kessler	Kevin Fellows	Williams Tony
Cris Sarabia	Lee Alexanderson	Wilkinson Veronica
Daniel Berger	Margot Jacobs	Padilla
David Nahai		

CITY AND OTHER AGENCY PARTICIPANTS

The One Water LA team would like to thank the individuals from the City and other agencies who contributed to the One Water LA 2040 Plan.

Alex Chu	Gene Edwards	Mario Dimzon
Alice Gong	Hagu Solomon-Carry	Marisela Reyes
Ammar Eltawil	Hamid Tadayon	Marisol Ibarra
Ariel Flores	Hassan Rad	Michael Scaduto
Barry Berggren	Heather Johnson	Michael Simpson
Beth Scheafer	Herbert Corleto	Mike Lee
Bladimir Campos	Hi Sang Kim	Mike Ruiz
Brandon Kawaguchi	Ida Meisami-Fard	Ninh Hong
Brian McCormick	Javier Dennis	Paul Blasman
Bruce Lapid	Jennifer Kong	Ray Solomon
Carlos Santos	Joe Linn	Richard Fortman
Chris DeMonbrun	Jon Ball	Robert Vega
Christine Heinrich-Josties	Jose Lozano	Rodell Zorilla
Colin Kumabe	Judy Agustin	Ron Mayuyu
Curtis Tran	Kabew Kassew	Rudy Torres
Darryl Pon	Kosta Kaporis	Seung Tag-Oh
David Takata	Kwasi Berko	Spencer Yu
Dawn Petschaeur	Kyle Yoder	Taraneh Nik-Khah
Eddie Perez	Laura Bauernfeind	Todd Nguyen
Edward Arrington	Lily Zheng	Uriel Matus
Elizabeth Fernandez	Lisa Naples	Vijay Desai
Fernando Gonzalez	Lonnie Ayers	Vivian Marquez
	Loudmilla Vertanessian	Wendy Dinh

CAROLLO ENGINEERS, INC. (PRIME CONSULTANT)

Gil Crozes.....	Principal-in-Charge
Inge Wiersema.....	Project Manager
Tom West.....	(former) Project Manager
Jacquelin Reed	Assistant Project Manager
Matt Huang.....	Task Lead for Future Integration Opportunities
Sarah Deslauriers.....	Task Lead for Climate Resilience Assessment
Ryan Hejka.....	Task Lead for Flow Conditions & Mass Balance Tool
Bronwyn Kelly	Task Lead for Stormwater Facilities Plan
Pavitra Rammohan	(former) Task Lead for Stormwater Facilities Plan & LA River Flow Study
Robb Grantham	Technical Lead Funding Strategies
Chao-An Chiu	Mass Balance Tool Programming Support
Amy Martin.....	Future Integration Opportunities Analysis Support
Aimee Zhao.....	Future Integration Opportunities Analysis Support
Elisa Garvey	Future Integration Opportunities Analysis Support
Pierce Rossum.....	Funding Strategies support staff
David Crosse.....	Funding Strategies support staff
Leneyde Chavez	Stakeholder Engagement Support
Eric Mills.....	Technical Review
Lou Carella.....	Technical Review
Susan Gilbert.....	Technical Review
Charlie He	Technical Review
Jackie Silber.....	GIS Specialist
Lana Luburic.....	Graphic Designer
Silvia Backlund	Graphic Designer
Chris Hurlburt	Document Processing

SUBCONSULTANTS

Arcadis

Venu Kolli..... Project Manager & Technical Coordinator EWWIS Study

Baylis Group

Jack Baylis Special Topic Group Facilitator & Strategic Planning Group Member

CDM Smith

Hampik Dekermenjian Facilitator & Strategic Planning Group Member

Jennifer Thompson..... Project Manager

Robin Nezhad (former) Project Manager

Arthur Goh..... Technical Lead for Rancho Park & MacArthur Park Concept Reports

Tiffany Lin..... Technical Lead for Special Studies – San Pedro Gateway Concept Report

Andrea White Rancho Park Concept Report & On-Site Treatment Financial Impact Study

Theresa Jurotich On-Site Treatment Financial Impact Study

Eric Smith..... On-Site Treatment Study Survey

Andrea Loutsch..... Funding Strategies Support Staff

CH2M

Judi Miller..... Project Manager & Task Lead LA River Flow Study

William McMillin Task Lead for Climate Resilience Assessment

Armin Munévar Climate Resilience Assessment Technical Lead

Amanda Heise Climate Resilience Assessment Support Staff

Tapas Das Climate Resilience Assessment Support Staff

Jeff Friesen Wastewater Flow Projections

Jagjit Kaur LA River Flow Study Support Staff

Cordoba

Danielle Chupa Project Manager & Support Staff

Jenny Morataya Plan Recommendations Timeline Support Staff

Narbeh Issagholian Policy Feasibility Evaluation Framework

DakeLuna

Miguel LunaFacilitator for LA River Stakeholder Workshop

Glen Dake Special Topic Group Facilitator

Fehr & Peers

Jeremy Klop Technical Coordinator on Transportation Elements

Geosyntec

Mark Hanna Project Manager & Task Lead for Stormwater Facilities Plan

Christopher Wessel Stormwater Facilities Plan Technical Lead

Curtis Fang.....Stormwater Facilities Plan Support Staff & GIS mapping

Stacey Luell Stormwater Facilities Plan Support Staff

Megan Otto Stormwater Facilities Plan Support Staff

Kaitlyn Hanley.....Stormwater Facilities Plan Support Staff

Al Preston.....LA River Flow Study Technical Lead

Jai PanthailLA River Flow Study Support Staff

Ken Susilo.....Technical Review

John Robinson Consulting

John Robinson Grant Funding Opportunities Support Staff

Katz & Associates

Karen SnyderStakeholder Engagement Support Lead

Sara KatzStrategic Stakeholder Engagement Planning

Camille StephensStakeholder Engagement Support Staff

Lewis Michaelson Public Participation Strategist and Facilitator

Joan Isaacson.....Public Participation Plan

Patty Post..... Marketing Strategies Plan

Patricia TennysonSpecial Topics Group Facilitator

Kris Helm Consulting

Kris Helm Stormwater Facilities Plan Financial Analysis

Larry Walker & Associates

Tom GrovhougStormwater Facilities Plan Support Staff

M2 Resource Consulting, Inc.

Karen Miller Task Lead – Existing Integration Opportunities & Plan Support

Morcos Group

Sherif Morcos GIS Mapping Lead

Paradigm Environmental

Dustin Bambic Stormwater Facilities Plan Modeling Support

SEITec

Shariar EftekharzadehLA River Flow Study Support Staff

Stephen Groner & Associates

Stephen Groner Special Topic Group Facilitator

Stantec (formerly MWH)

Sarah MungerProject Manager & Task Lead for Wastewater Facilities Plan

Areeba Syed Wastewater Facilities Plan Project Engineer

Jon Abelson Wastewater Facilities Plan Support Staff

Connie Adera Wastewater Facilities Plan Support Staff

Ryan Kristensen Wastewater Facilities Plan Support Staff

Kyleen Marcella Wastewater Facilities Plan Support Staff

Chisa Whelan Wastewater Facilities Plan GIS Support

Jim StahlWastewater Facilities Plan Technical Review

Don BassettWastewater Facilities Plan Technical Review

Tetra Tech

Ira Artz Project Manager & Hydraulic/Hydrologic Analysis LA River

Jeff BarnaBiologic and Habitat Analysis LA River

ONE WATER LA STAKEHOLDERS

We would like to acknowledge and sincerely thank the following individuals and their organizations for contributing to the Plan's development through their participation in One Water LA Workshops and Meetings.

Name	Organization
Aayushi Jain	Los Angeles Cleantech Incubator
Adi Liberman	Proposition O Citizens Oversight Advisory Committee
Agustine Rios	Individual
Alex Paxton	Water Foundation
Alexander Robinson	USC School of Architecture
Alexandra Nagy	Food and Water Watch
Alyssa Go	Edison Water Resources
Amanda Begley	TreePeople
Amanda Griesbach	Heal the Bay

Name	Organization
Amanda Maki	Desal Response Group
Amelia Meyer	ARUP
Andy Hui	Metropolitan Water District of Southern California
Andy Lipkis	TreePeople
Andy Plai	Individual
Angie Song	Trust for Public Land
Anisha Hingorani	Los Angeles Food Policy Council
Anthea Raymond	Los Angeles Kayak Club
Aram Hacobian	Individual
Aram Hernandez	Perkins+Will
Armando Flores	Valley Industry & Commerce Association (VICA)
Arnold Epstein	City of Beverly Hills - Water Technical Committee
Arthur Golding	Arthur Golding & Associates
Azita Yazdani	Exergy
Barbara Ringuette	Silver Lake Improvement Association
Barry Edelman	Tarzana Neighborhood Council
Barry Hibbs	Cal State LA - Department of Geological Sciences
Bill Hopkins	Granada Hills North Neighborhood Council
Bonny Bentzin	UCLA
Brad Cox	Los Angeles Business Council Institute
Brandon Matson	BizFed
Brenna Norton	Food & Water Watch
Brian Baldauf	Mountains Recreation and Conservation Authority
Brian St. German	Canoga Park Neighborhood Council
Bruce Reznik	Los Angeles Waterkeeper
Bryan Shiang	AdvTech Environmental Inc.
Carol N. Hart	North Hills West Neighborhood Council
Caroline Orija	Better Watts Initiative WLCAC
Carolyn Casavan	Sherman Oaks Neighborhood Council
Charles Eddy	FoLAR (board member)
Charles Savinar	North Hollywood West Neighborhood Council
Charlotte Pienkos	Nature Conservancy

Name	Organization
Charlyn Fernandez	Individual
Charming Evelyn	Sierra Club
Chris Sarabia	Greywater Action
Christian Frere	Apartment Association of Greater Los Angeles
Christine Frey	Metropolitan Water District
Christopher McKinnon	Mar Vista Community Council
Christopher Solek	U.S. Army Engineer District, Los Angeles Planning Division
Cindy Cleghorn	Sunland-Tujunga Neighborhood Council
Clint Granath	Forest Lawn Memorial Park
Conner Everts	Southern California Watershed Alliance - Desal Response Group
Craig Cadwallader	Surfrider foundation - South Bay Chapter
Craig Collins	Silver Lake Reservoirs Conservancy
Craig Kessler	Southern California Golf Association
Cris Morris	Los Angeles Regional Water Quality Control Board
Cristina Crespo	Individual
Dan Braun	LAANE
Daniel Berger	TreePeople
Daniel J. Rynn	City of Burbank - Public Works Department
Daniel Sciolini	Baldwin Hills Conservancy
Danielle Bram	Individual
Dasler Jimenez	Individual
Dave Keitel	Silver Lake Neighborhood Council
David Fink	Climate Resolve
David Nahai	David Nahai Companies
DeAndre Valencia	BIA-LAV
Deb Smith	Los Angeles Regional Water Quality Control Board
Debbie Enos	Watershed Conservation Authority
Deborah Weinstein-Bloome	TreePeople
Debra George	Encino Neighborhood Council
Delbara Dorsey	Everfield Consulting LLC
Dennis Knicely	Healing News Network
Denny Schneider	Alliance for a Regional Solution to Airport Congestion
Diana Campos	Los Angeles Community Garden Council
Diana Ward	UCLA Department of Geography
Diane Silva	The Trust for Public Land

Name	Organization
Don Dwiggins	Northridge East Neighborhood Council and NC Sustainability Alliance
Don Gauthier	LA Community College District Academic Senate
Dorothy Napoleon	Individual
Edith de Guzman	TreePeople
Edward Hitti	City of La Cañada
Edward Smith	Empowerment Congress Southwest Area Neighborhood Development Council
Eileen Alduenda	Council for Watershed Health
Elizabeth Hawley	Valley Industry and Commerce Association (VICA)
Eugene Allevato	Pacoima Neighborhood Council
Evelyn Hernandez	Central American Resource Center
Francesca Corra	Studio City Beautification Association
Frank Wada	Lincoln Heights Neighborhood Council
Gary Aggas	Sun Valley Area Neighborhood Council
Genaro Mejia	ASCE - LA Chapter; Metropolitan Los Angeles Branch
George Wolfberg	Santa Monica Canyon Civic Association
Ghina Yamout	Alta Environmental
Ginachi Amah	Los Angeles Regional Water Quality Control Board
Glen Dake	LA Community Garden Council
Glenn Bailey	Los Angeles Neighborhood Council Coalition
Grant Hoag	Office of Public Accountability - Ratepayer Advocate
Grant Jean	The River Project
Gregory Pierce	UCLA Luskin Center
Gregory Wright	SONC Green Committee, Wright Thinking, Tradetech
Grove Pashley	Individual
Guangyu Wang	Santa Monica Bay Restoration Commission
Gwendolyn Henry	Northwest San Pedro Neighborhood Council
Heidi Dexheimer	Individual
Insley Julier	Surfrider Foundation
Jack Humphreville	Greater Wilshire Neighborhood Council
Jacqueline McMillen	Alta Environmental
James Badnar	Metropolitan Water District
Jamie Guzman	CAHSR
Jan Dyer	Mia Lehrer + Associates

Name	Organization
Jeanette Vosburg	Sierra Club
Jennifer Samson	LA River Revitalization Corporation
Jennifer Truong	The River Project
Jenny Low	Occidental College
Jessica Salans	Ground Game LA
Jill Edelman	ZGF Architectes LLP
Jill Sourial	The Nature Conservancy
John Dorsey	Loyola Marymount University / Dept. Civil Engineering & Env. Science
John S. Lang	South Shores Homeowners Association
Johnathan Perisho	The River Project
Jon Bassinger	Individual
Jon Switalski	River LA
Jonathan Katz	Cinnabar
Joseph Dugo	O Green Solutions
Joyce Dillard	Individual
Joyce Greene	Tarzana Neighborhood Council
Julia Potter	California State University Northridge
Justin Yee	Urban Waters Federal Partnership
Karen Reed	USC
Kari Huinker	Greater Echo Park Elysian Neighborhood Council
Katie Mika	UCLA
Keel Robinson	Xylem, Inc.
Kelly Comras	Pacific Palisades Neighborhood Council
Kelly Ryan	The River Project
Ken Dine	Individual
Ken Murray, MD	Wilderness Corps
Ken Russell	Individual
Kenneth Wyrick	Caltek
Kermit Remmsham	SoCal Golf Association
Kevin Fellows	Parsons Brinckerhoff
Kevin Hardy	National Water Research Institute
Kirsten James	Heal the Bay
Kit Cole	Kit Cole Consulting
Lara Weatherly	The Nature Conservancy

Name	Organization
Larry Tudor	Rio Tinto
Laura Allen	Greywater Action
Laura Mack	Neighborhood Council Sustainability Alliance
Laura Saltzman	Mountains Recreation and Conservation Authority
Linda Escalante	Natural Resources Defense Council
Lora Hall	Silverlake Reservoirs Conservancy
Louise McCarthy	Community Clinic Association of Los Angeles
Madelyn Glickfeld	UCLA
Marcos Pinheiro	Hatch Mott MacDonald
Margot Jacobs	Mia Lehrer + Associates (MLA)
Maria Camacho	LA River Revitalization Corporation
Maria Mehranian	Cordoba Corp
Maria Salinas	West Adams Neighborhood Council
Maricela Macias	Consulate General of Canada
Mark Gold, D.Env.	UCLA, Institute of the Environment
Mark Grey	Building Industry Association of Southern California
Mark Hall	Greater Los Angeles County Vector Control District
Mark Mutter	ARCADIS
Mark Osokow	San Fernando Valley Audubon Society
Mark Pampanin	Sierra Club
Maryann Kuk	Silver Lake Reservoirs Conservancy
Maryjane MacLeod	Contech Engineered Solutions
Matt Romero	Mia Lehrer + Associates
Matthew King	Heal the Bay
Maurice Oillataguerre	City of Glendale - Public Works Department
Max Podemski	Pacoima Beautiful
Melanie Winter	The River Project
Melissa Von Mayrhauser	LA Waterkeeper
Meredith McCarthy	Heal the Bay
Michael Rood	Kiewit Infrastructure West Co.
Michael Shiang	AdvTech Environmental Inc.
Michelle Dornfest	East Solution, Inc.
Michelle Krupkin	Mar Vista Community Council
Michelle Lin	LA Waterkeeper
Michelle Mehta	Natural Resources Defense Council

Name	Organization
Mike Antos	California State University Northridge
Mike Meador	California Greenworks
Mike O'Gara	Sun Valley Area Neighborhood Council
Mirko Maher	Michael Baker International
Monobina Mukherjee	UCLA, Institute of Environment and Sustainability =
Nancy Steele	Council for Watershed Health
Natalia Gaerlan	The Trust for Public Land
Noel Sullivan	Individual
Nora Hakkakzadeh	Coalition for our Water Future, EOS
Nurit Katz	UCLA
Omar Brownson	LA River Revitalization Corporation
Paola Machan	Mujeres de La Tierra
Patricia Jones	Southwest Neighborhood Council
Paul Herzog	Surfrider Foundation
Pete Benjamin	Individual
Peter Arnold	Arid lands Institute
Peter J. Kim	Sierra Club, Water Committee
Raissa Dameive	The Art of Living
Ramon Guevara	LA County Emergency Preparedness of Response, Policy & Planning Unit
Raul Medina	LA Regional Water Quality Control Board
Rebecca Fesdwan	Water Foundation
Renee Nahum	Silver Lake Neighborhood Council
Rina Gabbay	Photo Voltaics
Rita Kampalath	County of Los Angeles, Chief Sustainability Office
Robin Mark	The Trust for Public Land
Rocand Chung	AdvTech Environmental Inc.
Romel Pascual	CicLAvia
Rosalie Preston	Harbor Gateway North Neighborhood Council
Ross Zelen	VerdeXchange
Rusty Millar	Silver Lake Neighborhood Council
Ruth Doxsee	Lake Balboa Neighborhood Council
Ryan Allen	LADT

Name	Organization
Sarah Rascon	Mountains Recreation and Conservation Authority
Saud Cistic	WSP
Sayd Randle	Yale University - School of Forestry & Env Studies
Scotty Probert	Friends of the Los Angeles River
Seraphine Logshad	Longshadow Studios
Sergio Lambarri	Atwater Village Neighborhood Council
Sharon Szmolyan Stein	EnviroLine
Sharyn Romano	Los Angeles Beautification Team
Shawn Warren	Friends of the Los Angeles River
Sherri Akers	Mar Vista Community Council
Sherry Sidick	California State University Northridge
Shona Ganguly	The Nature Conservancy
Sonia Lopez	Individual
Stephanie Barton	SLRC
Stephanie Pincetl, PhD	UCLA, Institute of the Environment
Stephanie Taylor	Green LA Coalition
Stephen Mejia	Friends of the Los Angeles River
Steve Johnson	Heal the Bay
Steven Quat	Studio City Neighborhood Council
Steven Williams	Selva International-Eco Gardens; Surfrider Foundation -Eco Friendly Gardens
Sue Ann Ballat	Gang Alternatives Project
Susan Brownstein	California Department of Public Health
Suzanne Sharkey	NWRI
Tamsyn Hunnewell	Sustainable Works
Tawny Valencia	DigDeep
Theresa Deitlin	Individual
Tom Persons	Habitat Works
Tom Williams, M.S., Ph.D.	Citizens Coalition for a Safe Community/Sierra Club Water Committee
Tony Wilkinson	Neighborhood Council MOU Oversight Committee
Tracy Quinn	Natural Resources Defense Council
Tracy Seligman	Individual
Ty Teissere	Greywater Action

Name	Organization
Vanessa Thompson	Arup
Vera Padilla	Lincoln Heights Neighborhood Council
Veronica Padilla	Pacoima Beautiful
Walker Foley	Food and Water Watch
Wendy Ramallo	Council for Watershed Health
Wendy Talaro	Biomimicry Los Angeles
Yareli Sanchez	Council for Watershed Health

* Over three hundred additional stakeholders received meeting invitations and informational updates.

CITY OF LOS ANGELES

VOLUME 1: ONE WATER LA 2040 PLAN – SUMMARY REPORT

TABLE OF CONTENTS

	<u>Page No.</u>
EXECUTIVE SUMMARY	
ES.1	PLAN PURPOSE..... ES-1
ES.2	PLAN BACKGROUND..... ES-1
ES.3	ONE WATER LA VISION, OBJECTIVES, AND GUIDING PRINCIPLES..... ES-2
ES.4	PLAN ELEMENTS AND DEVELOPMENT PROCESS ES-3
ES.4.1	Leveraging Existing Planning Efforts..... ES-3
ES.4.2	Water Management Goals..... ES-4
ES.4.3	Collaboration and Stakeholder Engagement..... ES-5
ES.5	PLAN OUTCOMES..... ES-8
ES.5.1	Integrated Urban Water Cycle..... ES-9
ES.5.2	Integration Outcomes and Momentum..... ES-11
ES.5.3	Planning for a more Resilient Future ES-11
ES.6	STORMWATER AND URBAN RUNOFF FACILITIES PLAN..... ES-11
ES.6.1	Stormwater and Receiving Water Quality Goals..... ES-12
ES.6.2	Stormwater Planning Approach..... ES-13
ES.6.3	Stormwater Improvement Program..... ES-14
ES.6.4	Stormwater and Urban Runoff Facilities Plan Recommendations..... ES-18
ES.7	WASTEWATER FACILITIES PLAN..... ES-19
ES.7.1	Potable and Non-Potable Reuse ES-19
ES.7.2	Water Reclamation Plants ES-20
ES.7.3	Wastewater System Planning Approach ES-20
ES.7.4	Wastewater System Recommendations by Plant..... ES-21
ES.7.5	Recommended Wastewater Projects..... ES-26
ES.8	CURRENT INTEGRATION OPPORTUNITIES..... ES-27
ES.8.1	Recommended Current Integration Opportunities..... ES-31
ES.9	FUTURE INTEGRATION OPPORTUNITIES ES-31
ES.9.1	Water Management Strategies ES-32
ES.9.2	Recommended Future Integration Opportunities ES-41
ES.10	POLICIES AND PROGRAMS ES-44
ES.11	ONE WATER LA IMPLEMENTATION STRATEGY..... ES-49
ES.11.1	Phasing Periods..... ES-49
ES.11.2	Plan Recommendations..... ES-49
ES.11.3	Funding Needs and Recommendations ES-53
ES.11.4	Funding Strategies ES-54
ES.12	NEXT STEPS ES-56
CHAPTER 1 – INTRODUCTION	
1.1	BACKGROUND..... 1-1
1.2	PLAN ELEMENTS AND DEVELOPMENT PROCESS 1-2
1.3	ONE WATER LA VISION, OBJECTIVES, AND GUIDING PRINCIPLES..... 1-3
1.3.1	One Water LA Vision Statement 1-3
1.3.2	One Water LA Objectives and Guiding Principles 1-4
1.4	LEVERAGING EXISTING PLANNING EFFORTS..... 1-7
1.5	PLAN OUTCOMES..... 1-13

1.6 STUDY AREA DESCRIPTION 1-18
 1.6.1 City of Los Angeles 1-18
 1.6.2 Geography and Climate..... 1-18
 1.6.3 Watersheds..... 1-20
 1.6.4 Groundwater Basins..... 1-20
 1.6.5 Potable Water Service Area 1-20
 1.6.6 Wastewater Service Area and Sewersheds 1-22
 1.7 PLAN ORGANIZATION..... 1-24
 1.8 PROJECT TEAM..... 1-25

CHAPTER 2 – PLAN COLLABORATION AND STAKEHOLDER ENGAGEMENT

2.1 INSTITUTIONAL FRAMEWORK 2-2
 2.1.1 City Organization..... 2-2
 2.1.2 Inter-Departmental Focus Meetings 2-2
 2.1.3 Regional Agencies 2-5
 2.1.4 Steering Committee 2-6
 2.2 STAKEHOLDER ENGAGEMENT 2-9
 2.2.1 One Water LA Advisory Group 2-9
 2.2.2 One Water LA Stakeholder Group 2-10
 2.2.3 Special Topic Groups..... 2-13
 2.2.4 Strategic Planning Group 2-15
 2.3 ACCOMPLISHMENTS TO DATE 2-15
 2.4 ONGOING COLLABORATION AND ENGAGEMENT ACTIVITIES 2-18
 2.4.1 Community Engagement..... 2-18
 2.4.2 Continued Inter-Departmental and Agency Collaboration 2-18
 2.4.3 Future Engagement Activities..... 2-19

CHAPTER 3 – EXISTING WATER MANAGEMENT STRATEGIES

3.1 EXISTING WATER MANAGEMENT CHALLENGES 3-1
 3.2 EXISTING WATER SUPPLIES 3-2
 3.2.1 Existing Water Supply Mix..... 3-2
 3.2.2 Reducing Reliance on Imported Water 3-5
 3.2.3 Local Supply Development Goals..... 3-7
 3.3 WATER CONSERVATION..... 3-7
 3.3.1 Existing Conservation Programs..... 3-9
 3.3.2 Accomplishments to Date..... 3-10
 3.3.3 Ongoing and Planned Efforts..... 3-10
 3.4 GROUNDWATER 3-10
 3.4.1 Overview of Groundwater Basins 3-11
 3.4.2 Maximizing Utilization of Other Groundwater Basins..... 3-13
 3.5 RECYCLED WATER 3-14
 3.5.1 Recycled Water Supply Sources 3-15
 3.5.2 Existing Non-Potable Reuse..... 3-17
 3.5.3 Accomplishments to Date..... 3-17
 3.6 STORMWATER..... 3-19
 3.6.1 Watersheds..... 3-19
 3.6.2 Stormwater Quality Goals 3-20
 3.6.3 Existing Stormwater Capture and Use Methods..... 3-20
 3.6.4 Accomplishments to Date..... 3-22
 3.7 LOS ANGELES RIVER 3-24
 3.7.1 LA River Reaches..... 3-26
 3.7.2 Existing LA River Studies and Plans 3-27

CHAPTER 4 – FLOWS AND DEMANDS

4.1 CITY-WIDE FLOW BALANCE OVERVIEW 4-1

4.2 HISTORICAL FLOWS AND DEMANDS 4-2

 4.2.1 Potable Water Demands 4-2

 4.2.2 Wastewater Flows 4-3

 4.2.3 Recycled Water 4-5

 4.2.4 Stormwater 4-8

 4.2.5 River and Ocean Flows 4-12

4.3 FUTURE FLOWS AND DEMANDS 4-13

 4.3.1 Key Assumptions, Targets, and Goals 4-13

 4.3.2 Potable Water 4-14

 4.3.3 Wastewater 4-15

 4.3.4 Recycled Water 4-15

 4.3.5 Stormwater 4-17

 4.3.6 River and Ocean Flows 4-19

4.4 MASS BALANCE TOOL 4-20

4.5 FLOW BALANCE SUMMARY 4-25

CHAPTER 5 – CURRENT INTEGRATION OPPORTUNITIES

5.1 PURPOSE 5-1

5.2 SELECTION AND DEVELOPMENT PROCESS 5-1

 5.2.1 Step 1 - Gathering of Current Integration Opportunity Ideas 5-2

 5.2.2 Step 2 - Screening of Integration Opportunities 5-3

 5.2.3 Step 3 - Development of Project Fact Sheets 5-3

 5.2.4 Step 4 - Ranking of the Top 10 Integration Opportunities 5-4

 5.2.5 Step 5 - Conceptual Development of the Top 5 Case Studies 5-5

5.3 CURRENT INTEGRATION PROJECT DESCRIPTIONS 5-8

 5.3.1 Rancho Park Water Reclamation Facility 5-8

 5.3.2 Advanced Treated Recycled Water Delivery to LAX and Scattergood 5-10

 5.3.3 Capture of Off-Site Stormwater at LAUSD Schools 5-15

 5.3.4 Water Related Opportunities for the LA Zoo's Master Plan 5-18

5.4 ADDITIONAL CURRENT INTEGRATION OPPORTUNITIES 5-22

5.5 NEXT STEPS 5-23

CHAPTER 6 – FUTURE INTEGRATION OPPORTUNITIES

6.1 PURPOSE 6-1

6.2 POTENTIAL FUTURE INTEGRATION STRATEGIES 6-1

6.3 EVALUATION PROCESS 6-3

 6.3.1 Methodology Overview 6-4

 6.3.2 Evaluation Criteria 6-6

 6.3.3 Criteria Weighting Factors 6-10

6.4 CONCEPT OPTIONS 6-12

 6.4.1 Concept Scoring Process 6-15

6.5 PORTFOLIO EVALUATION 6-19

 6.5.1 Portfolio Descriptions 6-23

 6.5.2 Portfolio Evaluation Criteria 6-28

 6.5.3 Portfolio Evaluation Results 6-29

 6.5.4 Preferred Portfolio 6-30

6.6 PREFERRED PORTFOLIO 6-33

 6.6.1 Summary of Preferred Portfolio 6-40

CHAPTER 7 – WASTEWATER FACILITIES PLAN

7.1 WASTEWATER FACILITY PLAN PURPOSE..... 7-1

7.2 BASIS OF PLANNING..... 7-2

 7.2.1 Wastewater System Service Area..... 7-3

 7.2.2 Wastewater Flow Projections..... 7-6

 7.2.3 Non-Potable Reuse..... 7-9

 7.2.4 Potable Reuse 7-10

 7.2.5 Regulatory Drivers..... 7-10

7.3 WASTEWATER COLLECTION SYSTEM 7-12

 7.3.1 Existing Collection System 7-12

 7.3.2 Near-Term Planned Collection System Improvements 7-12

 7.3.3 Long-Term Collection System Improvements 7-13

7.4 WATER RECLAMATION PLANTS..... 7-14

 7.4.1 HWRP 7-15

 7.4.2 DCTWRP 7-17

 7.4.3 LAGWRP 7-19

 7.4.4 TIWRP7-21

7.5 FUTURE WASTEWATER SYSTEM ANALYSIS..... 7-23

 7.5.1 HWRP 7-24

 7.5.2 DCTWRP 7-31

 7.5.3 LAGWRP 7-38

 7.5.4 TIWRP7-43

 7.5.5 Potential Future Water Reclamation Plant Options 7-44

 7.5.6 On-Site Treatment 7-44

7.6 BIOSOLIDS MANAGEMENT..... 7-45

7.7 CLIMATE RISK ASSESSMENT FOR WASTEWATER INFRASTRUCTURE..... 7-46

7.8 WASTEWATER FACILITIES ADAPTIVE CAPITAL IMPROVEMENT PLAN 7-47

 7.8.1 Cost Estimating Assumptions..... 7-47

 7.8.2 CIP Planning Phases and Project Categories 7-48

 7.8.3 In-Progress Projects 7-49

 7.8.4 Current Integration Opportunities 7-50

 7.8.5 Future Integration Opportunities..... 7-50

 7.8.6 Estimated and Projected CIP Summary 7-51

 7.8.7 WWFP Adaptive CIP 7-51

 7.8.8 Escalated CIP..... 7-54

CHAPTER 8 – STORMWATER AND URBAN RUNOFF FACILITIES PLAN

8.1 INTRODUCTION 8-1

8.2 REGULATORY BACKGROUND 8-3

 8.2.1 Water Quality Regulations 8-3

 8.2.2 City of LA Water Supply Directives..... 8-4

 8.2.3 Flood Risk Management..... 8-4

8.3 STORMWATER AND DRY WEATHER RUNOFF FLOW DEFINITIONS 8-5

 8.3.1 Watershed Management Area Overview..... 8-6

 8.3.2 Estimated Stormwater Flows..... 8-6

 8.3.3 Historical Dry Weather Runoff 8-9

8.4 EXISTING STORMWATER SYSTEM 8-9

 8.4.1 Key Players: Roles and Responsibilities 8-9

 8.4.2 Existing System Overview 8-10

8.5 OPERATIONS AND MAINTENANCE 8-11

8.6 INTEGRATED STORMWATER MANAGEMENT APPROACH..... 8-12

8.6.1 The Practical Project Manager – The Three-Legged Stool..... 8-12

8.6.2 Water Quality Improvement Projects 8-12

8.6.3 Water Supply Improvement Projects..... 8-13

8.6.4 Flood Risk Mitigation Projects 8-14

8.6.5 Multi-Benefit Stormwater Projects 8-16

8.7 STORMWATER IMPROVEMENT PROGRAM..... 8-17

8.7.1 Project Database Development..... 8-17

8.7.2 Stormwater Project Selection Overview 8-18

8.7.3 Stormwater Database Overview 8-19

8.8 STORMWATER RELATED POLICY RECOMMENDATIONS..... 8-21

8.9 FINANCIAL STRATEGY..... 8-22

8.9.1 Amortized SIP Cost..... 8-22

8.9.2 Current Funding Mechanisms 8-23

8.9.3 Assumptions for Future Funding 8-24

8.10 CONCLUSIONS AND RECOMMENDATIONS 8-26

CHAPTER 9 – PLAN RECOMMENDATIONS AND IMPLEMENTATION STRATEGY

9.1 CATEGORIES OF PLAN RECOMMENDATIONS 9-1

9.2 PHASING PERIODS 9-3

9.3 CURRENT INTEGRATION OPPORTUNITIES..... 9-4

9.3.1 Phasing Assumptions..... 9-4

9.3.2 Cost Estimates..... 9-6

9.3.3 Cost Summary by Phase 9-7

9.4 FUTURE INTEGRATION OPPORTUNITIES 9-7

9.4.1 Phasing Assumptions..... 9-10

9.4.2 Cost Estimates..... 9-11

9.4.3 Cost Estimate Summary by Phase 9-12

9.5 WASTEWATER PROJECTS..... 9-13

9.5.1 Phasing Assumptions..... 9-15

9.5.2 Cost Estimates..... 9-15

9.5.3 Cost Summary by Phase 9-17

9.6 STORMWATER PROJECTS AND PROGRAMS 9-19

9.6.1 Phasing Assumptions..... 9-21

9.6.2 Cost Estimates..... 9-22

9.6.3 Cost Summary by Phase 9-24

9.7 POLICIES AND PROGRAMS 9-26

9.7.1 One Water LA Phase 1 Quick-Fixes Overview 9-26

9.7.2 Phase 2 Policy and Program Development 9-29

9.7.3 Policy Consolidation and Refinement 9-30

9.7.4 Policy and Program Classification 9-33

9.7.5 Prioritization of Policies and Programs 9-34

9.7.6 Policies Presented to the Water Cabinet..... 9-37

9.7.7 Future Policy and Program Considerations 9-37

9.8 PROJECT TIMELINES SUMMARY 9-38

9.9 ADAPTIVE IMPLEMENTATION STRATEGY..... 9-43

9.9.1 Project Triggers..... 9-43

9.9.2 Trigger-Based Implementation Strategy 9-51

CHAPTER 10 – FUNDING NEEDS AND NEXT STEPS

10.1 FUNDING NEEDS & RECOMMENDATIONS 10-1
 10.2 POTENTIAL FUNDING SOURCES 10-3
 10.2.1 Existing Utility Revenues 10-4
 10.2.2 Voter-Approved Tax Measures 10-4
 10.2.3 Grants and Loan Programs 10-5
 10.2.4 Partnerships 10-8
 10.2.5 Additional Alternatives 10-9
 10.2.6 Funding and Cost-Sharing Methodologies 10-10
 10.3 NEXT STEPS 10-12
 10.3.1 Programmatic Environmental Impact Report 10-13
 10.3.2 Continued Inter-Departmental Collaboration & Coordination 10-14
 10.3.3 Future One Water LA Plan Updates and Reporting 10-16

LIST OF APPENDICES

APPENDIX A References
 APPENDIX B Future Integration Opportunities
 APPENDIX C Wastewater Projects
 APPENDIX D Stormwater Projects
 APPENDIX E Policies and Programs

LIST OF TABLES

Table ES.1 New Concept Options of Preferred Portfolio ES-35
 Table ES.2 Summary of Prioritized Policies and Programs ES-46
 Table ES.3 Potential Fiscal Impacts for Plan Recommendations ES-50

 Table 1.1 One Water LA's Impact on Water Integration 1-16

 Table 2.1 Regional Agencies 2-5
 Table 2.2 Summary of Steering Committee Meetings 2-8
 Table 2.3 Summary of Advisory Group Meetings 2-11
 Table 2.4 Summary of Stakeholder Group Workshops/Meetings 2-12
 Table 2.5 Summary of Special Topic Groups Meetings 2-14

 Table 3.1 Potential Recycled Water Supply Summary by Plant 3-15

 Table 4.1 Existing Recycled Water Demand Summary (2015-16) 4-7
 Table 4.2 Demand and Flow Summary by Planning Year 4-25

 Table 5.1 Number of Current Integration Opportunities by Agency 5-2
 Table 5.2 Scoring and Ranking Criteria 5-4
 Table 5.3 Top 10 Current Integration Opportunities and Top 5 Case Studies 5-6
 Table 5.4 Recycled Water Delivery to LAX and Scattergood Generating Station: Capital
 Cost Estimates 5-13
 Table 5.5 Potential Recycled Water and Stormwater Uses at the LA Zoo 5-19
 Table 5.6 Potential Potable Water Demand Offsets 5-20

Table 6.1	Economic Criteria Definitions.....	6-7
Table 6.2	Resiliency Criteria Definitions	6-8
Table 6.3	Implementation Criteria Definitions.....	6-9
Table 6.4	Environmental Criteria Definitions.....	6-10
Table 6.5	List of Concept Options.....	6-13
Table 6.6	Portfolio Definitions	6-20
Table 6.7	Portfolio Summary	6-22
Table 6.8	In-Progress Projects and Programs.....	6-25
Table 6.9	Planned Stormwater Management Projects	6-26
Table 6.10	Evaluation Metrics Summary	6-28
Table 6.11	Preferred Portfolio - Estimated Yield and Cost of New Concept Options.....	6-32
Table 7.1	Projected Wastewater Flows	7-7
Table 7.2	Future Regulatory Drivers for WRP Planning.....	7-11
Table 7.3	Near-Term Wastewater Collection System Improvements.....	7-13
Table 7.4	Water Reclamation Plant Summary.....	7-14
Table 7.5	Water Reuse Concept Options	7-23
Table 7.6	HWRP Concept Options	7-25
Table 7.7	HWRP Flow Assumptions.....	7-27
Table 7.8	DCTWRP Concept Options	7-32
Table 7.9	DCTWRP Flow Assumptions	7-34
Table 7.10	LAGWRP Concept Options	7-38
Table 7.11	LAGWRP Flow Assumptions.....	7-40
Table 7.12	TWRP Flow Assumptions	7-43
Table 7.13	Summary of In Progress Project Estimated Costs	7-49
Table 7.14	Summary of Concept Option Portfolios.....	7-51
Table 7.15	WWFP Adaptive CIP Summary 2017 (\$M)	7-52
Table 8.1	Distribution of Average Daily and Annual Stormwater Flows	8-8
Table 8.2	Select List of Key Agencies.....	8-10
Table 8.3	Identified Existing Grey Infrastructure in City of LA.....	8-10
Table 8.4	Green Streets Implementation Schedule Comparison.....	8-18
Table 8.5	Green Streets Programs Cost Summary.....	8-20
Table 8.6	Funding Deficit Summary	8-25
Table 9.1	Cost Summary of Current Integration Opportunities	9-6
Table 9.2	Preferred Portfolio Future Integration Opportunities.....	9-8
Table 9.3	Estimated Cost of Future Integration Opportunities	9-11
Table 9.4	Estimated Cost of Wastewater Projects by Treatment Plant.....	9-15
Table 9.5	Estimated Cost of Wastewater Projects by Project Category	9-16
Table 9.6	Cost Summary of Stormwater Projects and Programs by Watershed	9-22
Table 9.7	Cost Summary of Stormwater Projects and Programs by Project Type	9-23
Table 9.8	Summary of Prioritized Policies and Programs	9-35
Table 9.9	Summary of Capital Cost Phasing by Project Category.....	9-38
Table 9.10	Capital Cost Summary by Project Category	9-39
Table 10.1	Available Loan and Grant Funds.....	10-6

LIST OF FIGURES

Figure ES.1 Los Angeles' Future Smart Urban Water Cycle..... ES-10

Figure ES.2 Summary of Stormwater Projects by Watershed ES-17

Figure ES.3 Estimated Cost Distribution of Stormwater Projects by Project Type ES-18

Figure ES.4 Summary of Wastewater Projects by WRP ES-22

Figure ES.5 Estimated Cost Distribution of Wastewater Projects by WRP ES-26

Figure ES.6 Location of Current Integration Opportunities..... ES-28

Figure ES.7 Concept Options Overview Map ES-34

Figure ES.8 Dry Weather Low Flow Diversions ES-36

Figure ES.9 LA River Recharge into LA Forebay using Injection Wells..... ES-37

Figure ES.10 Potable Reuse - MBR at Hyperion WRP to Regional System..... ES-38

Figure ES.11 Potable Reuse Raw Water Augmentation - Tillman WRP to Los Angeles
Aqueduct Filtration Plant ES-39

Figure ES.12 Potable Reuse Treated Water Augmentation - LA-Glendale WRP to
Headworks Reservoir ES-40

Figure ES.13 East-West Valley Interceptor Sewer ES-41

Figure ES.14 Estimated Cost Distribution of Future Integration Opportunities..... ES-42

Figure ES.15 Trigger-Based Implementation Strategy for Future Integration Opportunities..... ES-43

Figure ES.16 One Water LA Policy and Program Development Process ES-44

Figure ES.17 Potential Fiscal Impact by Project Category ES-52

Figure ES.18 Potential Fiscal Impact by Phase and Project Category ES-53

Figure 1.1 One Water LA 2040 Plan Elements 1-2

Figure 1.2 One Water LA Objectives and Guiding Principles 1-5

Figure 1.3 Sustainable City pLAN Goals Supported by One Water LA..... 1-8

Figure 1.4 EWMP Boundaries 1-10

Figure 1.5 Los Angeles' Future Smart Urban Water Cycle..... 1-15

Figure 1.6 Watersheds 1-19

Figure 1.7 Groundwater Basins 1-21

Figure 1.8 City Sewage Service Area 1-23

Figure 2.1 Multiple Levels of Stakeholder Engagement..... 2-1

Figure 2.2 City Department Organization 2-3

Figure 2.3 Steering Committee Members 2-7

Figure 3.1 Existing Sources of Water Supply..... 3-3

Figure 3.2 5-Year Historical Supply Mix Average (2011-2016) 3-4

Figure 3.3 Supply Mix in FY 2015/16 (dry) and Projected for FY 2017/18 (wet) 3-5

Figure 3.4 Water Demand and Population through Time..... 3-8

Figure 3.5 Example of California-Friendly Landscaping 3-9

Figure 3.6 Average Five-Year Groundwater Production by Basin..... 3-11

Figure 3.7 Existing Recycled Water System and Facilities 3-16

Figure 3.8 Recycled Water Deliveries through Time..... 3-18

Figure 3.9 Hansen Spreading Grounds 3-22

Figure 3.10 LA Zoo Parking Lot Stormwater Infiltration..... 3-23

Figure 3.11 Example of a Green Alley..... 3-23

Figure 3.12 LA River and Major Creeks 3-25

Figure 3.13 Example of Unlined Portion of LA River 3-26

Figure 4.1 2016 Supply Mix – with and without Water Conservation 4-2

Figure 4.2 Historical Water Demand 4-3

Figure 4.3 Existing Wastewater Generated by Source (2015)..... 4-4

Figure 4.4 Existing Wastewater Influent Flows by Plant (2015) 4-4

Figure 4.5	Range in Dry and Wet Weather Wastewater Flows (2007-2016).....	4-5
Figure 4.6	Existing Recycled Water Demands by Service Area (2016).....	4-6
Figure 4.7	Existing Recycled Water Supplies by Plant (2016).....	4-7
Figure 4.8	Existing Stormwater Supplies (2016).....	4-8
Figure 4.9	Historical Precipitation from 1922 to 2016.....	4-9
Figure 4.10	Typical Stormwater Flows.....	4-10
Figure 4.11	Existing Sources of Flows to Rivers (Normal Year).....	4-12
Figure 4.12	Existing Sources of Flows to Ocean (Normal Year).....	4-13
Figure 4.13	Projected Supply Mix for Year 2040.....	4-14
Figure 4.14	Baseline Wastewater Forecast.....	4-15
Figure 4.15	Recycled Water Demand Forecast.....	4-16
Figure 4.16	Projected Recycled Water Supplies and Demands (2040).....	4-17
Figure 4.17	Stormwater Flow Estimates.....	4-18
Figure 4.18	Projected Ocean Discharges.....	4-19
Figure 4.19	Mass Balance Tool – Map View.....	4-21
Figure 4.20	Mass Balance Tool – User Dashboard View.....	4-22
Figure 4.21	One Water Diagram of Major Flows and Demands.....	4-23
Figure 5.1	Case Study Selection and Development Process.....	5-2
Figure 5.2	Location of Top 10 Current Integration Opportunities.....	5-7
Figure 5.3	Rancho Park Project Site Location.....	5-9
Figure 5.4	Alternative Project Locations.....	5-9
Figure 5.5	Recycled Water Delivery to LAX and Scattergood: Project Location Map and Layout.....	5-12
Figure 5.6	Conceptual Layout of Off-Site Stormwater Capture and On-Site Infiltration.....	5-16
Figure 6.1	Future Integration Strategy Stakeholder Survey Results.....	6-3
Figure 6.2	Evaluation Methodology.....	6-4
Figure 6.3	Evaluation Categories and Criteria.....	6-6
Figure 6.4	Concept Criteria Weighting Factors.....	6-11
Figure 6.5	Concept Options Overview Map.....	6-14
Figure 6.6	Yield-weighted Unit Costs by Concept and Strategy.....	6-16
Figure 6.7	Concept Options Weighted Scores by Rank.....	6-18
Figure 6.8	Establishing Portfolio Themes.....	6-19
Figure 6.9	Portfolio Sensitivity Analysis Process.....	6-21
Figure 6.10	Benchmark Portfolio Components.....	6-24
Figure 6.11	Preferred Portfolio Map.....	6-31
Figure 6.12	Preferred Portfolio - 2040 Supply Mix for a Normal and Dry Year.....	6-33
Figure 6.13	Dry Weather Low Flow Diversions.....	6-34
Figure 6.14	LA River Recharge into LA Forebay using Injection Wells.....	6-35
Figure 6.15	Potable Reuse - MBR at Hyperion WRP to Regional System.....	6-36
Figure 6.16	Potable Reuse Raw Water Augmentation - Tillman WRP to Los Angeles Aqueduct Filtration Plant.....	6-37
Figure 6.17	Potable Reuse Treated Water Augmentation - LA-Glendale WRP to Headworks Reservoir.....	6-38
Figure 6.18	East West Valley Interceptor Sewer.....	6-39
Figure 6.19	Estimated Cost Distribution of Future Integration Opportunities.....	6-40
Figure 7.1	HSA and TISA Service Boundaries.....	7-4
Figure 7.2	Los Angeles Sewersheds.....	7-5
Figure 7.3	Projected and Historical Average Annual Wastewater Flows.....	7-6
Figure 7.4	Low Flow Diversions.....	7-8
Figure 7.5	Wastewater Flow Projections by WRP.....	7-9
Figure 7.6	Process Flow Diagram for HWRP.....	7-16

Figure 7.7 Process Flow Diagram for DCTWRP 7-18

Figure 7.8 Process Flow Diagram for LAGWRP 7-20

Figure 7.9 Process Flow Diagram for TIWRP 7-22

Figure 7.10 Trigger-Based Implementation Strategy for HWRP 7-26

Figure 7.11 Estimated Flow Availability for Water Reuse from HWRP (2040 Projection) 7-28

Figure 7.12 Process Flow Schematic for Concept Option #13 (MBR at HWRP to Regional System) 7-29

Figure 7.13 Potential Upgrades for Concept Option #13 (MBR at HWRP to Regional System) 7-30

Figure 7.14 Trigger-Based Implementation Strategy for DCTWRP 7-33

Figure 7.15 Estimated Flow Availability for Water Reuse from DCTWRP (2040 Projection) 7-34

Figure 7.16 Process Flow Schematic Concept Option #22 (East-West Valley Interceptor Sewer)..... 7-35

Figure 7.17 Process Flow Schematic for Concept Option #15 (DCTWRP to LAAFP)..... 7-36

Figure 7.18 Potential Expansion Areas for Concept Option #15 (DCTWRP to LAAFP)..... 7-37

Figure 7.19 Trigger-Based Implementation Strategy for LAGWRP 7-39

Figure 7.20 Estimated Flow Availability for Water Reuse from LAGWRP (2040 Projection) 7-40

Figure 7.21 Process Flow Schematic Concept Option #17 (LAGWRP to Headworks Reservoir)..... 7-41

Figure 7.22 Potential Process Location for Concept Option #17 (LAGWRP to Headworks Reservoir)..... 7-42

Figure 7.23 Estimated Flow Availability for Water Reuse from TIWRP (2040 Projection) 7-43

Figure 7.24 WWFP Adaptive CIP Summary by Phase..... 7-53

Figure 7.25 WWFP Adaptive CIP by Category 7-53

Figure 7.26 CIP Comparison of Net Present Values..... 7-54

Figure 7.27 Timeline for Wastewater Facilities Plan..... 7-56

Figure 8.1 Illustration of the "Three-Legged Stool" Stormwater Planning 8-2

Figure 8.2 WMA Boundaries and SCMP Subwatersheds within the City of LA 8-7

Figure 8.3 Water Quality System Considerations..... 8-13

Figure 8.4 Water Supply System Considerations..... 8-14

Figure 8.5 Flood Risk Management System Considerations 8-15

Figure 8.6 Integrated Water Resources System Considerations 8-16

Figure 8.7 Capital Cost Distribution by Project Category and SIP Phase..... 8-21

Figure 8.8 Amortized Annual SIP Cost through Year 2042 8-22

Figure 8.9 Non-monetary Economic Benefits of Stormwater Investments 8-23

Figure 8.10 Deficiencies between Existing Revenues and Project Costs..... 8-24

Figure 8.11 Comparison between Potential Funding and Cost Obligation 8-25

Figure 9.1 Location of Current Integration Opportunities..... 9-5

Figure 9.2 Capital Cost Phasing of Current Integration Opportunities 9-7

Figure 9.3 Location of Future Integration Opportunities 9-9

Figure 9.4 Estimated Cost of Future Integration Opportunities 9-12

Figure 9.5 Estimated Capital Cost Phasing of Future Integration Opportunities 9-13

Figure 9.6 Summary of Wastewater Projects by WRP 9-14

Figure 9.7 Estimated Cost of Wastewater Projects by Treatment Plant..... 9-16

Figure 9.8 Estimated Cost of Wastewater Projects by Project Category 9-17

Figure 9.9 Capital Cost Phasing of Wastewater Projects by Treatment Plant..... 9-18

Figure 9.10 Capital Cost Phasing of Wastewater Projects by Project Type 9-18

Figure 9.11 Summary of Stormwater Projects by Watershed 9-20

Figure 9.12 TMDL Compliance Deadlines by Watershed 9-21

Figure 9.13 Cost Distribution of Stormwater Projects and Programs by Watershed 9-23

Figure 9.14 Cost Distribution of Stormwater Projects by Project Type 9-24

Figure 9.15 Estimated Capital Cost Phasing of Stormwater Projects by Watershed..... 9-25

Figure 9.16	Estimated Capital Cost Phasing of Stormwater Projects by Project Type.....	9-25
Figure 9.17	Recommended Timeline and Cost of Stormwater Projects and Programs	9-27
Figure 9.18	One Water LA Policy Development Process	9-29
Figure 9.19	Stakeholder Engagement Process.....	9-31
Figure 9.20	City's Policy Development Process.....	9-32
Figure 9.21	Policy and Program Classification Exercise.....	9-33
Figure 9.22	Policy & Program Classification Results	9-34
Figure 9.23	Summary of Capital Cost Phasing by Project Category.....	9-38
Figure 9.24	Cost Distribution Summary by Project Category	9-40
Figure 9.25	Summary of Recommended Timelines by Project Category	9-41
Figure 9.26	Trigger-Based Implementation Strategy HWRP.....	9-52
Figure 9.27	Trigger-Based Implementation Strategy for DCTWRP.....	9-55
Figure 9.28	Trigger-Based Implementation Strategy for LAGWRP	9-58
Figure 9.29	Trigger-Based Implementation Strategy for LA River.....	9-60
Figure 10.1	Cost-Sharing Strategy	10-11
Figure 10.2	Adel Hagekhalil (LASAN's Assistant Director) and Marty Adams (LADWP's Chief Operating Officer) led the regional collaboration at a VerdeExchange Water Charette (June, 2017)	10-13
Figure 10.3	Example of a Trigger Tracking Form	10-17

LIST OF VOLUMES

VOLUME 1:	SUMMARY REPORT
VOLUME 2:	WASTEWATER FACILITIES PLAN
VOLUME 3:	STORMWATER & URBAN RUNOFF FACILITIES PLAN
VOLUME 4:	LA RIVER FLOW STUDY
VOLUME 5:	INTEGRATION OPPORTUNITIES ANALYSIS DETAILS
VOLUME 6:	CLIMATE RISK AND RESILIENCE ASSESSMENT FOR WASTEWATER AND STORMWATER INFRASTRUCTURE
VOLUME 7:	IMPLEMENTATION STRATEGY SUPPORTING DOCUMENTS
VOLUME 8:	TECHNICAL SUPPORT MATERIALS
VOLUME 9:	STAKEHOLDER ENGAGEMENT MATERIALS
VOLUME 10:	PROGRAMMATIC ENVIRONMENTAL IMPACT REPORT

Content Overview of Volumes 2-9 of the One Water LA 2040 Plan Summary Report One Water LA 2040 Plan	
Volume & Topic	Volume Title & Technical Memoranda
VOLUME 2	WASTEWATER FACILITIES PLAN
Main Report	Executive Summary
	Chapter 1 - Introduction
	Chapter 2 - Basis of Planning
	Chapter 3 - Wastewater Collection System
	Chapter 4 - Hyperion Water Reclamation Plant
	Chapter 5 - Donald C. Tillman Water Reclamation Plant
	Chapter 6 - Los Angeles-Glendale Water Reclamation Plant
	Chapter 7 - Terminal Island Water Reclamation Plant
	Chapter 8 - Potential Future Water Reclamation Plants
	Chapter 9 - Biosolids Management
	Chapter 10 - Climate Risk and Resilience Assessment for Wastewater Infrastructure
	Chapter 11 - Wastewater Facilities Adaptive Capital Improvement Plan
Appendices	A-H: References, Concept Options, CIP, and Supporting Materials
VOLUME 3	STORMWATER & URBAN RUNOFF FACILITIES PLAN
Main Report	Executive Summary
	Chapter 1 - Introduction
	Chapter 2 - Regulatory Background
	Chapter 3 - Stormwater and Dry Weather Runoff Flows
	Chapter 4 - Existing Stormwater System
	Chapter 5 - Operations and Maintenance
	Chapter 6 - Integrated Stormwater Management Analysis
	Chapter 7 - Stormwater Improvement Program
	Chapter 8 - Financial Strategy
Chapter 9 - Conclusions and Recommendations	
Appendices	A-I: References, Glossary, Figures, and Master Project Database
VOLUME 4	LA RIVER FLOW STUDY
Main Report	TM 12.4 - LA River Flow Study
Appendices	Appendix A - References
	Appendix B - Review of Historical LA River Ecological Surveys
	Appendix C - Los Angeles River Low Flow Study
	Appendix D - Review of ARBOR Project Flows
	Appendix E - LA River Water Storage Potential Study
	Appendix F - Executive Summary of The Nature Conservancy Study

Content Overview of Volumes 2-9 of the One Water LA 2040 Plan Summary Report One Water LA 2040 Plan	
Volume & Topic	Volume Title & Technical Memoranda
VOLUME 5	
INTEGRATION OPPORTUNITIES ANALYSIS DETAILS	
Current Integration Opportunities	TM 1.3 - Project Summary
	TM 3.1 - Current Integration Project Opportunities
	TM 3.2 - Current Integration Opportunities Case Studies
Future Integration Opportunities	TM 5.1 - Basis of Planning
	TM 5.2 - Future Concepts Development
	TM 5.3 - Portfolio Evaluation
VOLUME 6	
CLIMATE RISK AND RESILIENCE ASSESSMENT FOR WASTEWATER AND STORMWATER INFRASTRUCTURE	
Main Report	TM 5.5 - Climate Risk and Resilience Assessment for Wastewater and Stormwater Infrastructure
Appendices	Appendix A - References
	Appendix B - Historical and Potential Future Climate Conditions
	Appendix C - Consequences Categories and Level Descriptions
	Appendix D - Replace-in-Kind and Resilience Improvement Cost Methodologies
	Appendix E - Facility Risk Assessment and Adaptation Summary Sheets
	Appendix F - EPA Los Angeles Sanitation Climate Change Risk Assessment and Adaptation Measure Recommendations for Wastewater Assets
VOLUME 7	
IMPLEMENTATION STRATEGY SUPPORTING DOCUMENTS	
Institutional Framework	TM 1.1 - Roles and Responsibilities
Regulations	TM 2.2 - Expected Future Regulatory Conditions
Policies	TM 13.1 - Policies and Programs
Funding	TM 4.1 - Funding Opportunities
	TM 4.2 - Water Funding Tools

Content Overview of Volumes 2-9 of the One Water LA 2040 Plan Summary Report One Water LA 2040 Plan	
Volume & Topic	Volume Title & Technical Memoranda
VOLUME 8	TECHNICAL SUPPORT MATERIALS
Flow Conditions	TM 1.2 - Existing Flow Conditions
	TM 2.1 - Future Flow Conditions
On-Site Treatment Analysis	TM 12.5.1 - Onsite Treatment Policy Survey
	TM 12.5.2 - Onsite Treatment Evaluation of Impacts
	TM 12.5.3 - Onsite Treatment Policy Recommendations
	TM 12.6 - Onsite Wastewater Treatment Plan Policy Study – Financial Impacts Study
Graywater Impacts and Concerns	Graywater Impacts and Concerns
Recycled Water Usage in Concrete	Evaluating Municipal Recycled Water Usage in Concrete Mixes
Climate Resilient Tree List	Climate Resilient Tree List
VOLUME 9	STAKEHOLDER ENGAGEMENT MATERIALS
Guiding Principles Report	Phase 1 Guiding Principles Report
Stakeholder Engagement	TM 18.1 - Public Engagement Plan
	TM 18.2 - Communication Plan
Meeting Materials	Steering Committee Meetings
	Advisory Group Meetings
	Stakeholder Workshops
	Special Topic Groups Meetings
	Inter-Departmental Focus Meetings
	Academic Partnerships and School Education
Progress Report	One Water LA Progress Report: A Collaborative Approach to Integrated Water Management
One Water LA Brochures	Fact sheets and Progress Summary
Other Engagement Activities	Other meetings and engagement activities
VOLUME 10	PROGRAMMATIC ENVIRONMENTAL IMPACT REPORT

LIST OF ABBREVIATIONS

Abbreviation	Description
\$/AF	dollars per acre-foot
\$M	millions of dollars
°C	degrees Celsius
°F	degrees Fahrenheit
µm	micrometer
AACE	Association for the Advancement of Cost Engineering
AAWRE	American Academy of Water Resources Engineers
ac	acre
ADA	Americans with Disabilities Act
ADF	average day flow
ADWF	average dry-weather flow
AF	acre-feet
AFD	acre-feet per day
AFY or afy	acre-feet per year
AGB	Aerated Grit Basins
AGWO	active groundwater outflow
AMEL	average monthly effluent limitation
AOP	advanced oxidation process
APA	allowable pumping allocation
APHIS	Animal and Plant Health Inspection Service
AQMD	Air Quality Management District
AR4	Fourth Assessment Report
AR5	Fifth Assessment Report
ARBOR	Area with Restoration Benefits and Opportunities for Revitalization
AS	activated sludge
ASBS	Areas of Special Biological Significance
ASCE	American Society of Civil Engineers
ASR	aquifer storage and recovery
ATFs	air treatment facilities
Avg TDS	average TDS
AVORS	Additional Valley Outfall Relief Sewer
AWPF	Advanced Water Purification Facility
AWT	advanced water treatment
AWTF	advanced water treatment facility
BAC	biologically activated carbon
BAF	biological aerated filter
Basin Study	Los Angeles Basin Stormwater Conservation Study
BC	Ballona Creek
BCSD	bias correction and spatial downscaling
BFE	base flood elevation
BM	Burns McDonnell
BMPs	Best Management Practices

Abbreviation	Description
BNR	biological nitrogen removal
BOD	biochemical oxygen demand
BOD/SS/TDS	biochemical oxygen demand/suspended solids/total dissolved solids
BOD ₅	5-day biochemical oxygen demand
BOE	Los Angeles Bureau of Engineering
BOR	U.S. Bureau of Reclamation
BOS	Bureau of Sanitation (aka LASAN)
BPAs	Basin Plan Amendments
BPI	Blue Plan-it®
BRK	brick
BSS	building and safety
BSS	Bureau of Street Services
BTF	biotrickling filters
BWP	Burbank Water and Power
BWRP	Burbank Water Reclamation Plant
BWSC	Boston Water and Sewer Commission
C	conservation
CAL FIRE	California Department of Forestry and Fire Protection
Cal OES	California Office of Emergency Services
CAIRecycle	Department of Recycling and Recovery
Caltrans	California Department of Transportation
CAO	City Administrative Officer
CARB	California Air Resources Board
CASQA	California Stormwater Quality Association
CAT	California Climate Action Team
CB	Central Basin
CBMWD	Central Basin Municipal Water District
cBOD	carbonaceous biochemical oxygen demand
CBWRP	Central Basin Water Rights Panel
CCAMP	California Coastal Analysis and Mapping Project
CCI	Construction Cost Index
CCPP	calcium carbonate precipitation potential
CCR	California Code of Regulations
CCTAG	Climate Change Technical Advisory Group
CCTV	closed circuit television
CDBG	Community Development Block Grant
CDC	Children's Discovery Center
CDPH	California Department of Public Health
CDS®	Continuous Deflector System
CDWR	California Department of Water Resources
CEC	constituents of emerging concern
CEQA	California Environmental Quality Act
CERP	Capital Equipment Replacement Program

Abbreviation	Description
cf _d	cubic feet per day
cf _h	cubic feet per hour
cf _m /lb	cubic feet per minute per pound
cf _s	cubic feet per second
CFSC	Central Flare System Controller
CHSRA	California High Speed Rail Authority
CIP	Capital Improvement Plan
CIRS	Coastal Interceptor Relief Sewer
CIS	Coastal Interceptor Sewer
City	City of Los Angeles
Cl ₂	chlorine gas
CLARTS	Central Los Angeles Refuse Transfer Station
cm	centimeters
CMAS	completely mixed activated sludge
CMIP3	Coupled Model Intercomparison Project Phase 3
CMIP5	Coupled Model Intercomparison Project Phase 5
CMOM	capacity management, operations, and maintenance
CMP	coordinated monitoring plan
CMP	corrugated metal pipe
CO ₂	carbon dioxide
Co-CAT	Coastal and Ocean Working Group of the California Climate Action Team
COD	chemical oxygen demand
CON	unreinforced concrete
CONRAC	Consolidated Rent-A-Car Center
COS	Central Outfall Sewer
CoSMoS	Coastal Storms Modeling System
CRA	Colorado River Aqueduct
CREAT	Climate Resilience Evaluation and Awareness Tool
CREST	Cleaner Rivers through Effective Stakeholder led TMDLs
CRS	Community Rating System
CRWRF	Carson Regional Water Reclamation Facility
CSA	California Sustainability Alliance
CSD	contaminated storm drain
CSDPR	California State Department of Parks and Recreation
CSO	combined sewer overflow
CSWRCB	California State Water Resources Control Board
CT	clay tile
CT mg-min/L	contact time milligram - minute per liter
CTG	combustion turbine generator
CTR	California Toxics Rule
CUP	Central Utility Plant
CWA	Clean Water Act
CWH	Council for Watershed Health

Abbreviation	Description
CWP	Center for Watershed Protection
CWSRF	Clean Water State Revolving Fund
CY	current year
d/D	depth over diameter
DAF	dissolved air flotation
DBP	disinfection byproducts
DC	Dominguez Channel
DCAC	direct contract aftercooler
DCP	Department of City Planning
DCS	distributed control system
DCTWRP	Donald C. Tillman Water Reclamation Plant
DDW	Division of Drinking Water
DFE	design flood elevation
DGB	Dominguez Gap Barrier
DGBP	Dominguez Gap Barrier Project
DGUP	Digester Gas Utilization Project
DHI	Danish Hydraulic Institute, Inc.
DICE	Dewatering Interim Centrifuge Expansion
DJF	December–February
DO	dissolved oxygen
DONE	Department of Neighborhood Empowerment
DPH	Department of Public Health
DPR	direct potable reuse
DSA	Division of State Architect
dtpd	dry tons per day
DTSC	Department of Toxic Substances Control
DWF	dry weather flow
DWFD	dry and wet weather flow diversion
DWP	Department of Water and Power
DWR	California Department of Water Resources
DWRP	Downtown Water Recycling Project
DWSRF	Drinking Water State Revolving Fund
E2B	Education to Business
EBPR	enhanced biological phosphorus removal
ECIS	East Central Interceptor Sewer
ECL	Edward C. Little
ECLWRF	Edward C. Little Water Recycling Facility
ED#5	Executive Directive No. 5
EED	Environmental Engineering Division
EIR	Environmental Impact Report
EIS	Environmental Impact Statement
EL	elliptical
EMCs	event-mean concentrations

Abbreviation	Description
EMPAC	Enterprise Maintenance Planning and Control
EMS	Environmental Management System
ENR	Engineering News Record's
EPA	Environmental Protection Agency
EPP	Effluent Pumping Plant
EQ	equalization
ERA	Exceedance Response Actions
ERIS	Eagle Rock Interceptor Sewer
ERP	Enforcement Response Plan
ESB	engineered storage buffer
ESC	Environmental Significance Category
ESS	effluent suspended solids
ETo	evapotranspiration
EVIS	East Valley Interceptor Sewer
EVRS	East Valley Relief Sewer
EWMP	Enhanced Watershed Management Program
EWVIS	East-West Valley Interceptor Sewer
Facilities Plan	Stormwater and Urban Runoff Facility Plan
FAR	floor area ratio
FAST	Field Automation for Sanitation Trucks
FAT	full advanced treatment
FEMA	Federal Emergency Management Agency
FGTS	fuel gas treating system
FIRMS	flood insurance rate maps
FIS	flood insurance studies
FL	Foreman Line
FMA	Flood Mitigation Assistance
FMD	Financial Management Division
FMP	Floodplain Management Plan
FOG	fats, oil, and grease
fps	feet per second
FRM	Flood Risk Management
FRP	fiberglass-reinforced plastic
FSE	food service establishments
ft	feet (foot)
ft/day	feet per day
ft/sec	feet per second
ft/yr	feet per year
FTC	flow to the city
FY	fiscal year
GAC	granular activated carbon
gal	gallons
gal/ac/day	gallons per acre per day

Abbreviation	Description
gal/yr	gallons per year
GCM	general circulation model
gfd	gallons per square foot per day
GHG	greenhouse gas
GI	green infrastructure
GIS	Geographic Information System
GISP	General Industrial Stormwater Permit
GOX	gas oxygen
GPA	grade point average
gpcd	gallons per capita per day
gpd	gallons per day
gpd/imp acre	gallons per day per acre of impervious area
gpd/sq ft	gallons per day per square foot
gped	gallons per employee per day
gph	gallons per hour
gpm	gallons per minute
gpm/sq ft	gallons per minute per square foot
GPR	Green Project Reserve
GRASS	Greenways to Rivers Arterial Stormwater System
GRIP	Groundwater Reliability Improvement Program
GRRPs	Groundwater Replenishment Reuse Projects
GRRR	Groundwater Recharge Reuse Regulations
GSA	Groundwater Sustainability Agency
GSA	General Services Administration
GSD	General Services Department
GSI	Green Stormwater Infrastructure
GSIS	Groundwater System Improvement Study
GSP	Groundwater sustainability Plan
GWAM	Groundwater Augmentation Model
GWI	groundwater infiltration
GWR	groundwater replenishment
GWRP	Groundwater Replenishment Project
GWRS	Groundwater Replenishment System
Harbor	Los Angeles Outer Harbor
HAWPF	Hyperion Advanced Water Purification Facility
HB	Hollywood Basin
HBEF	Hyperion Bio-Energy Facility
HCF	hundred cubic feet
HEC-RAS	Hydrologic Engineering Center River Analysis System
HGS	Harbor Generation Station
HMA	Hazard Mitigation Assistance
HMGP	Hazard Mitigation Grant Program
hp	horsepower

Abbreviation	Description
HP	high pressure
HPE	high pressure effluent
HPO	high purity oxygen
HPO-AS	high purity oxygen-activated sludge
HRSG	heat recovery steam generators
HRT	hydraulic retention time
HSA	Hyperion Service Area
HSEPS	Hyperion Secondary Effluent Pump Station
HSR	High-Speed Rail
HUD	Housing and Urban Development
HVAC	heating, ventilating and air conditioning
HWRP	Hyperion Water Reclamation Plant
I&C	instrumentation and controls
I/I	inflow and infiltration
I-5	Interstate 5
IBC	International Building Code
IC/ID	illicit connection/illicit discharge
ID	identification number
IDF	intensity, duration, and frequency
IEBL	Inland Empire Brine Line
IEPR	independent external peer review
IFAS	integrated fixed-film activated sludge
IFR	Integrated Feasibility Report
IFWO	interflow volume
in	inch/inches
in/hr	inch/inches per hour
in/yr	inch/inches per year
IOU	investor-owned water utilities
IPCC	Intergovernmental Panel on Climate Change
IPLS	In-Plant Lift Station
IPR	indirect potable reuse
IPS	intermediate pump station
IRP	integrated resources plan
IRWD	Irvine Ranch Water District
IRWMP	Integrated Regional Water Management Plan
IU	industrial user
IWMD	Industrial Waste Management Division
IWP	Industrial Wastewater Permit
IWR	Integrated Water Resources
J2/3	Jurisdictions 2 and 3
J7	Jurisdiction 7
JPA	Joint Powers Authority
JWPCP	Joint Water Pollution Control Plant

Abbreviation	Description
klb/day	kilopounds per day
kW	kilowatt
kWh/AF	kilowatts hour per acre-foot
kWh/year	kilowatts per year
LA	Los Angeles
LA River	Los Angeles River
LA Zoo	Los Angeles Zoo
LAA	Los Angeles Aqueduct
LAAFP	Los Angeles Aqueduct Filtration Plant
LABOE	Los Angeles Bureau of Engineering
LABSS	Los Angeles Bureau of Street Services
LACC	Los Angeles Convention Center
LACDPH	Los Angeles County Department of Public Health
LACDPR	Los Angeles County Department of Recreation and Parks
LACDPW	Los Angeles County Department of Public Works
LACFCD	Los Angeles County Flood Control District
LACSD	Los Angeles County Sanitation District
LADBS	Los Angeles Department of Building and Safety
LADCP	Los Angeles Department of City Planning
LADOT	Los Angeles Department of Transportation
LADPW	Los Angeles Department of Public Works
LADWP	Los Angeles Department of Water and Power
LAFCO	Local Agency Formation Commission
LAGSD	Los Angeles Department of General Services
LAGWRP	Los Angeles-Glendale Water Reclamation Plant
LAMC	Los Angeles Municipal Code
LAMP	Landside Access Modernization Program
LAR	Los Angeles River
LAR Watershed	LA River Watershed
LARAP	Los Angeles Department of Recreation and Parks
LARCC	Los Angeles River Cooperation Committee
LARiverWorks	Los Angeles RiverWorks Office
LARRMP	Los Angeles River Revitalization Master Plan
LARWQCB	Los Angeles Regional Water Quality Control Board
LASAN	Los Angeles Sanitation
LATC	Los Angeles Trailer and Container Intermodal Facility
LAUSD	Los Angeles Unified School District
LAWA	Los Angeles World Airports
LAWINS	Los Angeles Wastewater Integrated Network System
LAX	Los Angeles International Airport
LAZTF	Los Angeles Zoo Treatment Facility
lbs	pounds
lbs/day	pounds per day

Abbreviation	Description
lbs/hr	pounds per hour
lbs/hr/sq ft	pounds per hour per square foot
lbs/LOX/hr	pounds per liquid oxygen per hour
lbs/sq ft/d	pounds per square foot per day
LCIS	La Cienega Interceptor Sewer
LCP	local control panels
LCSFVRS	La Cienega-San Fernando Valley Relief Sewer
LEED	Leadership in Energy and Environmental Design
LFD	low flow diversion
LFTF	low flow treatment facilities
LID	low impact development
LIU	local industrial user
LLARRMP	Lower Los Angeles River Revitalization Master Plan
LMU	Loyola Marymount University
LNOS	Lower North Outfall Sewer
LOCA	localized constructed analogs
LORP	Lower Owens River Project
LOX	liquid oxygen
LP	low pressure
LPE	low pressure effluent
LPP	locally preferred plan
LSI	Langlier's Saturation Index
LSPC	Load Simulation Program in C+
LSS	Life Support Systems
LT	long-term
LVMWD	Las Virgenes Municipal Water District
M	million
MAR	marine habitat
Max TDS	maximum TDS
MBAS	methylene blue-activated substances
MBBR	moving bed biofilm reactor
MBfR	membrane biofilm reactors
MBM	Mass Balance Model
MBR	membrane bioreactor
MBT	Mass Balance Tool
MCC	motor control center
MCL	maximum contaminant level
MCMs	minimal control measures
MCP	master control system
MdR	Marina del Rey
Metro	Metropolitan Transportation Authority
MF	membrane filtration
MF	microfiltration

Abbreviation	Description
MF/UF	microfiltration/ultrafiltration
MG	million gallons
MG/yr	million gallons per year
mg/L	milligrams per liter
mg/yr	milligrams per year
mgd	million gallons per day
MGY	million gallons per year
MH	manhole
MHHW	mean higher high water
mi	miles
MICLA	Municipal Improvement Corporation of Los Angeles
mL	milliliter
MLE	Modified Ludzack Ettinger
ml/L	milliliter per liter
MLLW	mean lower low water
MLSS	mixed liquor suspended solids
mm	millimeter
mm/yr	millimeters per year
MOA	Memorandum of Agreement
MOU	Memorandum of Understanding
MOV	most open valve
MPN	most probable number
MS4	Municipal Separate Storm Sewer System
MSC	Map Service Center
MSC	Midfield Satellite Concourse
MSL	mean sea level
MU	MIKE URBAN software
MUN	municipal and domestic supply
MVA	megavolt amperes
MW	megawatt
MWD	Metropolitan Water District
MWDSC	Metropolitan Water District of Southern California
MWELO	Model Water Efficient Landscape Ordinance
MWRA	Massachusetts Water Resources Authority
N ₂	nitrogen gas
N/A	not applicable
NACWA	National Association of Clean Water Agencies
NALS	numeric action levels
NaOCl	sodium hypochlorite
NaHSO ₃	sodium bisulfite
NAS	National Adaptation Strategy
NAVD88	North American Vertical Datum of 1988
NCB	North Central Basin

Abbreviation	Description
NCDC	National Climatic Data Center
NCOS	North Central Outfall Sewer
NDEA	nitrosodiethylamine
NdeN	nitrification and denitrification
NDMA	nitrosodimethylamine
NDN	nitrification/denitrification
NDPA	nitrosopropylamine
NEIS	North East Interceptor Sewer
NEPA	National Environmental Policy Act
NER	National Ecosystem Restoration
NF	nanofiltration
NFF	National Forest Foundation
NFHL	National Flood Hazard Layer
NFIP	National Flood Insurance Program
NFPA	National Fire Protection Association
ng/L	nanograms per liter
NGO	non-government organization
NH ₃ -N	ammonia nitrogen
NH ₄ OH	ammonia hydroxide
NHIS	North Hollywood Interceptor Sewer
NIS	nature-inspired system
NLs	Notification Levels
NO ₂ -N	nitrite
NO ₃ -N	nitrate
NOAA	National Oceanic and Atmospheric Administration
NOI	Notice of Intent
NORS	North Outfall Relief Sewer
NOS	North Outfall Sewer
NOX	nitrogen oxide
NPCC	New York City Panel on Climate Change
NPDES	National Pollutant Discharge Elimination System
NPR	non-potable reuse
NRC	National Research Council
NRCS	Natural Resources Conservation Service
NRDC	Natural Resources Defense Council
NSF	National Sanitary Foundation
NSFHAs	non-special flood hazard areas
NT	near-term
NTU	nephelometric turbidity unit
NWRI	National Water Research Institute
NYCDEP	New York City Department of Environmental Protection
O&M	operations and maintenance
O ₃ /BAF	ozone with biologically active filters

Abbreviation	Description
OCSD	Orange County Sanitation District
One Water LA	One Water LA 2040 Plan
OOC	Office of Operator Certification
Organic-N	organic nitrogen
ORP	oxidation-reduction potential
OSTFs	on-site treatment facilities
OWLA	One Water Los Angeles
OWTS	onsite wastewater treatment systems
P3	Public/Private Partnerships
PA	Public Assistance Grant Program
PAC	powder activated carbon
PAC	process air compressors
PACE	Property Assessed Clean Energy
PAYGO	Pay-As-You-Go
PBL	Planbureau voor de Leefomgeving (Netherlands Environmental Assessment Agency)
PCE	perchloroethylene
pCi/L	picocuries per liter
PDM	Pre-Disaster Mitigation
PDWF	peak dry weather flow
PE	primary effluent
PEIR	Programmatic Environmental Impact Report
Permit	Industrial Wastewater Permit
PIPP	Public Information and Participation Program
Plan	One Water LA 2040 Plan
pLAN	Sustainable City pLAN
PLC	programmable logic controller
POLA	Port of Los Angeles
POLB	Port of Long Beach
POTW	Publicly Owned Treatment Works
ppm	parts per million
ppmvd	parts per million by volume, dry basis
Precip.	Precipitation
Project	Recycled Water Case Study
Prop O	Proposition O
PROW	Public Right-of-Way
psi	pounds per square inch
psig	pounds per square inch gauge
PSPS	Primary Sludge Pump Station
PVC	polyvinyl chloride
PWWF	peak wet weather flow
QA/QC	quality assurance/quality control
QISP	qualified industrial stormwater practitioner
QSF	quality surcharge fee

Abbreviation	Description
R&R	replacement and rehabilitation
RAA	Reasonable Assurance Analysis
RAP	Los Angeles Department of Recreation and Parks
RAS	return activated sludge
RCH	Rios Clementi Hale
RCLD	replacement cost less depreciation
RCP	reinforced concrete pipe
RCP	Representative Concentration Pathways
RDI/I	rainfall dependent inflow and infiltration
REC-1	Water Contact Recreation
Risk MAP	Risk Mapping, Assessment, and Planning
RIVER	Riparian via Varied Ecological Reintroduction
RFP	Request for Proposal
RM	River Mile
RO	reach outflow
RO	reverse osmosis
ROW	right-of-way
RPA	Request for Public Assistance
RTP	Regional Transportation Plan
RW	recycled water
RW	reclaimed water
RWAG	Recycled Water Advisory Group
RWC	recycled water contribution
RWLs	receiving water limitations
RWMP	Recycled Water Master Plan
RWQCB	Regional Water Quality Control Board
RWQCB-LA	Los Angeles Regional Quality Water Control Board
SARI	Santa Ana River Interceptor
SAT	soil aquifer treatment
SAWPA	Santa Ana Watershed Protection Authority
SBR	sequencing batch reactor
SCADA	supervisory control and data acquisition
SCAG	Southern California Association of Governments
SCAQMD	South Coast Air Quality Management District
SCAR	Sewer Capacity Availability Review
Scattergood	Scattergood Generating Station
SCCB	Southern California Continental Borderland
scfm	standard cubic feet per minute
SCMP	Stormwater Capture Master Plan
SCR	selective catalytic reduction
SCS	Sustainable Communities Strategy
SCWC	Southern California Water Committee
SD	standard deviation

Abbreviation	Description
SD	storm drain
SDWA	Safe Drinking Water Act
SE	semi-elliptical
SFB	San Fernando Basin
SFEM	Sewer Flow Estimation Model
SFHAs	special flood hazard areas
SFV	San Fernando Valley
SG	spreading ground
SGS	Scattergood Generating Station
SIO	Scripps Institution of Oceanography
SIP	street-end interface points
SIP	sewer infiltration and inflow prevention
SIP	Stormwater Improvement Program
SIU	significant industrial user
SLR	sea level rise
SLRAP	Sea Level Rise Action Plan
SMART	Sewer Monitoring and Routing Terminal
SMB	Santa Monica Bay
SMB J2/3	Santa Monica Bay Jurisdictions 2 and 3
SMB J7	Santa Monica Bay Jurisdiction 7
SMB WMA	Santa Monica Bay Watershed Management Area
SMBBB	Santa Monica Bay Beaches Bacteria
SMCL	secondary maximum contaminant level
SMURRF	Santa Monica Urban Runoff Recycling Facility
SNMP	Salt and Nutrient Management Plans
SO ₂	sulfur dioxide gas
SOD	sediment oxygen demand
SOP	Standard Operating Procedure
SOR	surface overflow rate
SPAC	Stormwater Pollution Abatement Charge
SPCC	Spill Prevention, Control, and Countermeasure
sq ft	square feet
sq mi	square miles
SRES	Special Report on Emission Scenarios
SRT	solids retention time
SS	suspended solids
SSC	sewer service charge
SSMP	Sewer System Management Plan
SSO	sanitary sewer overflow
STG	Special Topic Groups
STG	steam turbine generator
SURO	sum of surface outflow
SUSMP	Standard Urban Stormwater Mitigation Plan

Abbreviation	Description
SUSTAIN	System for Urban Stormwater Treatment and Analysis Integration
SVI	sludge volume index
SW	stormwater
SWD	side water depth
SWF	Service Water Facility
SWFP	Stormwater and Urban Runoff Facilities Plan
SWP	State Water Project
SWPPP	Stormwater Pollution Prevention Plan
SWRCB	State Water Resources Control Board
SWRF	Southwest Water Reclamation Facility
SWTP	surface water treatment plant
TO	Future Terminal O
Tapia	Tapia Water Reclamation Facility
TBD	to be determined
TBIT	Tom Bradley Internatinonal Terminal
TCE	trichloroethylene
TDH	total dynamic head
TDS	total dissolved solids
THM	trihalomethane
TI	Terminal Island
TIRE	Terminal Island Renewable Energy
TISA	Terminal Island Service Area
TIWRP	Terminal Island Water Reclamation Plant
TLF	truck loading facility
TM	Technical Memorandum
TMDL	total maximum daily load
TN	total nitrogen
TNC	The Nature Conservancy
TOC	total organic carbon
tpd	tons per day
TPL	Trust for Public Land
TSS	total suspended solids
TUa	acute toxic unit
TUc	chronic toxic unit
UCLA	University of California Los Angeles
UF	ultrafiltration
ULAR	Upper Los Angeles River
ULARA	Upper Los Angeles River Area
ULSFO	ultra-low sulfur fuel oil
UPRS	Uniform Project Reporting System
USACE	U.S. Army Corps of Engineers
USBR	U.S. Bureau of Reclamation
USC	University of Southern California

Abbreviation	Description
USDA	United States Department of Agriculture
USGS	U.S. Geological Survey
UV	ultraviolet
UV/AOP	ultraviolet advanced oxidation process
UV/NaOCl	ultraviolet irradiation/sodium hypochlorite
UWMP	Urban Water Management Plan
VAPP	Venice Auxiliary Pumping Plant
VCP	vitrified clay pipe
VFA	volatile fatty acids
VFD	variable frequency drive
VOC	volatile organic compounds
VORS	Valley Outfall Relief Sewer
VPP	Venice Pump Plant
VS	Valley Springs
VSL	Valley Spring Lane
VSL/FA	Valley Spring Lane/Forman Avenue
WARM	Existing Warm Freshwater Habitat
WARN	Water/Wastewater Agency Response Network
WAS	waste activated sludge
WASTF	Waste Activated Sludge Thickening Facility
Water IRP	2006 Water Integrated Water Resources Plan
WBMWD	West Basin Municipal Water District
WBPC	Water Body Pollutant Combination
WCB	West Coast Basin
WCBBP	West Coast Basin Barrier Project
WCIP	Wastewater Capital Improvement Plan
WDRs	Waste Discharge Requirements
WESD	Wastewater Engineering Services Division
West Basin	West Basin Water Recycling Facility
WET	wetland habitat
WETS	Water Engineering and Technical Services
WHIS	Wilshire-Hollywood Interceptor Sewer
WIFIA	Water Infrastructure Finance and Innovation Act
WIIN	Water Infrastructure Improvement for the Nation Act
WILD	Existing Wildlife Habitat
WLA	waste load allocation
WLA	West Los Angeles
WLAIS	West Los Angeles Interceptor Sewer
WMA	Watershed Management Area
WMMS	Watershed Management Modeling System
WMP	Watershed Management Programs
WPD	Watershed Protection Division
WQ	Water Quality

Abbreviation	Description
WQBELS	water quality-based effluent limits
WQCMPUR	Water Quality Compliance Master Plan for Urban Runoff
WQO	water quality objectives
WRAMPS	Watershed Reporting Adaptive Management and Planning System
WRD	Water Replenishment District
WRF	water reclamation facility
WRP	water reclamation plant
WRP	Water Recycling Project
WRS	Westwood Relief Sewer
WS	Water Supply
WTP	Water Treatment Plant
wtpd	wet tons per day
WW	wastewater
WWFP	Wastewater Facilities Plan
WWPOP	Wet Weather Preparedness and Operation Plan
WWTP	wastewater treatment plant
WY	water year
yd ³	cubic yards

GLOSSARY

Aqueduct	A pipe, conduit, or channel designed to transport water from a remote source, usually by gravity.
Aquifer (Confined)	Soil or rock below the land surface that is saturated with water. There are layers of impermeable material both above and below it and it is under pressure so that when the aquifer is penetrated by a well, the water will rise above the top of the aquifer.
Aquifer (Unconfined)	An aquifer whose upper water surface (water table) is at atmospheric pressure, and thus is able to rise and fall.
Artificial Recharge	Any process where water is put back into ground-water storage from surface-water supplies such as irrigation, or induced infiltration from streams or wells.
Augmentation	The process of adding recycled/reclaimed water that has received advanced treatment to an existing raw water supply (such as a reservoir, lake, river, wetland, and/or groundwater basin) that could eventually be used for drinking water after further treatment.
Base flow	Sustained, low flow discharge rate in a stream derived from groundwater discharge into the stream channel. During extended periods of low precipitation, base flow may account for most, or all, of the stream flow.
Beneficial uses	Designations for water bodies that (in California) Regional Water Quality Control Boards establish so appropriate water quality objectives can be established for that water body. The designated beneficial uses, together with water quality objectives form water quality standards. Such standards are mandated for all water bodies within the state under the California Water Code. In addition, the federal Clean Water Act mandates standards for all surface waters, including wetlands. In the Los Angeles Region, there are 24 Beneficial Use designations. Example designations include Municipal and Domestic Supply (MUN), Water Contact Recreation (REC-1), Wetland Habitat (WET), and Marine Habitat (MAR).
Best Management Practices (BMP)	Any program, technology, process, siting criteria, operating method, measure, or device that controls, prevents, removes, or reduces pollution.
Central Basin	Is the underground water basin or reservoir underlying Central Basin Area, the exterior boundaries of which Central Basin are the same as the exterior boundaries of Central Basin Area.
Clean Water Act (CWA)	The CWA establishes the basic structure for regulating discharges of pollutants into the waters of the United States and regulating quality standards for surface waters.
Collection system	The network of piping and pumping stations that conveys raw wastewater (sewage) from homes, businesses, etc., to a facility for treatment.

Colorado River Aqueduct	A 242-mile structure that transports water from the Colorado River to Southern California.
Commercial Water Use	Water used for motels, hotels, restaurants, office buildings, other commercial facilities, and institutions. Water for commercial uses comes both from public-supplied sources, such as a county water department, and self-supplied sources, such as local wells.
Conservation	Act of using the resources only when needed for the purpose of protecting from waste or loss of resources.
Conserve	To save a natural resource, such as water, through intelligent management and use.
Consumptive use	That part of water withdrawn that is evaporated, transpired, or incorporated into a manufactured product, or consumed by humans or animals, or otherwise removed from the immediate waterbody environment.
Council	The City Council of Los Angeles
Detention Basin	Surface or underground basins that capture flow and store it for later release under controlled conditions or reuse thereof, and additionally as to the Department of Water and Power of the City of Los Angeles, water brought into Central Basin area by that party by means of the Owens River Aqueduct.
Detention time	In storage reservoirs, the length of time water will be held before being used.
Direct potable reuse	The addition of advanced treated recycled water (purified water) directly to a potable water distribution system. See also potable reuse.
Direct Potable Reuse with Raw Water Augmentation	Planned placement of recycled water into a system of pipelines or aqueducts that deliver raw water to a drinking water treatment plant that provides water to a public water system.
Direct Potable Reuse with Treated Water Augmentation	Planned placement of recycled water into the water distribution system of a public water system. This is also called Direct Potable Reuse with Treated Drinking Water Augmentation.
Direct runoff	Water that flows over the ground surface or through the ground directly into streams, rivers, or lakes.
Discharge	The volume of water that passes a given point within a given period of time. It is an all-inclusive outflow term, describing a variety of flows such as from a pipe to a stream, or from a stream to a lake or ocean.
Discharge of pollutants	The rate of flow or volume of water passing a point in a given time. Expressed using a unit of volume over time, typically cubic feet per second. Any addition of any pollutant to navigable waters from any point source.
Domestic wastewater	Also called sanitary wastewater, consists of wastewater discharged from residences and from commercial, institutional, and similar facilities.

Domestic water use	Water used for household purposes such as drinking, food preparation, bathing, washing clothes, and dishes, watering lawns and gardens, flushing toilets etc. Also called residential water use.
Downstream	In the direction of a stream's current. For example, in the City of Los Angeles Hyperion Wastewater Treatment Plant is downstream to Donald C. Tillman Plant and the Los Angeles-Glendale Water Reclamation Plant; these plants are able to provide critical hydraulic relief to the City's major sewers downstream
Drawdown	A lowering of the ground-water surface caused by pumping.
Drought	A long period of below-average precipitation.
Dry Weather Urban Runoff	Runoff to the storm drain system that occurs when there is no measurable precipitation. Typically includes flows from car washing, landscape irrigation, street washing, dewatering during construction activities, and illicit connections and dumping into the storm drains.
Dry Well	An excavated pit lined with gravel or other porous materials to infiltrate stormwater.
Effluent	Municipal sewage or industrial liquid waste (untreated, partially treated, or completely treated) that flows out of a treatment plant, septic system, pipe, etc.
Environmental Protection Agency (EPA)	The U.S. agency responsible for efforts to control air and water pollution, radiation and pesticide hazards, ecological research, and solid waste disposal.
Filtration	A process that separates small particles from water by using a porous barrier to trap the particles and allowing the water through.
First Flush	The delivery of a highly concentrated pollutant loading during the early stages of a storm, due to the washing effect of runoff on pollutants that have accumulated on the land prior to the storm.
Flood	An overflow of water onto lands that are used or usable by man and not normally covered by water. Floods have two essential characteristics: The inundation of land is temporary; and the land is adjacent to and inundated by overflow from a river, stream, lake, or ocean.
Flood, 100-year	A 100-year flood does not refer to a flood that occurs once every 100 years, but to a flood level with a 1 percent chance of being equaled or exceeded in any given year.
Floodplain	A nearly level alluvial plain that borders a channel and is occasionally inundated by floods (unless artificially protected). This is formed by sediment, transport, and deposition from flows over the stream bank and lateral movement of the stream.
Freshwater	Water that contains less than 1000 mg/L of dissolved solids. Water that contains more than 500 mg/L of dissolved solids is undesirable for drinking water and many industrial uses.

Graywater	Gray water includes wastewater from bathtubs, showers, bathroom washbasins, clothes washing machines, and laundry tubs, but does not include wastewater from kitchen sinks or dishwashers.
Green Infrastructure	An adaptable term used to describe an array of products, technologies, and practices that use natural systems – or engineered systems that mimic natural processes – to enhance overall environmental quality and provide utility services. As a general principal, Green Infrastructure techniques use soils and vegetation to infiltrate, evapotranspirate, and/or recycle stormwater runoff.
Groundwater	(1) Water that flows or seeps downward and saturates soil or rock, supplying springs and wells. The upper surface of the saturate zone is called the water table. (2) Water stored underground in rock crevices and in the pores of geologic materials that make up the Earth's crust.
Groundwater Recharge	Inflow of water to a groundwater reservoir from the surface. Infiltration of precipitation and its movement to the water table is one form of natural recharge. Also, the volume of water added by this process.
Groundwater, Confined	Groundwater under pressure significantly greater than atmospheric, with its upper limit the bottom of a bed with hydraulic conductivity distinctly lower than that of the material in which the confined water occurs.
Groundwater, Unconfined	Water in an aquifer that has a water table that is exposed to the atmosphere.
Hardware Savings	A term used to quantify water use efficiency savings that is obtained through rebates, incentives, or direct install programs, that upgrade customers to water efficient fixtures or landscapes.
Hydrologic cycle	The representation of the cycle of water on earth based on all hydrologic processes and the interactions of water between the atmosphere, surface waters, polar ice, glaciers, and groundwater.
Imported Water	Water brought into the City of Los Angeles from a non-tributary source either from the Los Angeles Aqueduct, through purchase directly from the Metropolitan Water District of Southern California or by direct purchase from a member agency.
Indirect Potable Reuse with Groundwater Augmentation	Planned use of recycled water for replenishment of a groundwater basin or an aquifer that has been designated as a source of water supply for a public water system. This is also called Indirect Potable Reuse for Groundwater Recharge.
Infiltration	The absorption of water into the ground. The rate at which infiltration occurs is expressed in terms of depth per unit time, such as inches/hour.

Influent	Water volume flow rate or mass loading of a pollutant or other constituent into a water body or wastewater treatment plant.
Injection well	Refers to a well-constructed for the purpose of injecting treated wastewater directly into the ground. Wastewater is generally forced (pumped) into the well for dispersal or storage into a designated aquifer. Injection wells are generally drilled into aquifers that don't deliver drinking water, unused aquifers, or below freshwater levels.
Integrated Resource Planning (IRP)	A method for looking ahead using environmental, engineering, social, financial, and economic considerations; includes using the same criteria to evaluate both supply and demand options while involving customers and other stakeholders in the process.
Irrigation	The controlled application of water for agricultural purposes through manmade systems to supply water requirements not satisfied by rainfall.
Irrigation Water Use	Water application on lands to assist in the growing of crops and pastures or to maintain vegetative growth in recreational lands, such as parks and golf courses.
Low Flow	Minimum instantaneous stream flow during periods of low water runoff.
Low Impact Development (LID)	A sustainable landscaping approach that can be used to replicate or restore natural watershed functions and/or address targeted watershed goals and objectives.
Membrane Bioreactor MBR	A type of biological wastewater treatment process.
Microfiltration (MF)	The separation or removal from a liquid of particulates and microorganisms in the size range of 0.1 to 2 microns in diameter. (A micron is a millionth of a meter. A sheet of ordinary 20-weight copier paper is about 90 microns thick.)
Multiple Treatment Barriers	Each barrier is designed to provide substantial protection with redundant barriers for each type of treatment. A requirement for multiple barriers assures the overall water treatment process will remain effective if one treatment barrier were to fail.
National Pollutant Discharge Elimination System (NPDES)	A permit issued by the U.S. EPA or a state regulatory agency that sets specific limits on the type and amount of pollutants that a municipality or industry can discharge to a receiving water; it also includes a compliance schedule for achieving those limits. It is called the NPDES because the permit process was established under the National Pollutant Discharge Elimination System, under provisions of the Federal Clean Water Act.
Natural waters	Flowing waterbody within a physical system that has developed without human intervention, in which natural processes continue to take place; streams, rivers, lakes, bays, estuaries and coastal and open ocean are examples of natural waters.

Nonpoint Source	Pollution that is not released through pipes but rather originates from multiple sources over a relatively large drainage area. Non point sources can be divided into source activities related to either land or water use including failing septic tanks, improper animal-keeping practices, forest practices, and urban and rural runoff from a drainage basin.
Non-Potable	Water that may contain objectionable pollution, contamination, minerals, or infective agents and is considered unsafe and/or unpalatable for drinking.
Ocean Outfall	A large pipeline used to dispose of treated wastewater several miles offshore.
Onsite retrofits	Improvements or management practices that manage runoff before it reaches the storm drain system.
Osmosis	The movement of water molecules through a thin membrane. The osmosis process occurs in our bodies and is also one method of desalinating saline water.
Outfall	Location point where wastewater or stormwater flows from a conduit, stream, or drainage ditch into natural waters.
Pathogens	A microorganism capable of producing disease. Pathogens are of great concern to protect human health relative to drinking water, swimming beaches and shellfish beds.
Peak Flow	Maximum instantaneous streamflow during periods of high water runoff.
Per-capita use	The quantity of water used per person per day averaged over a time interval of 1 day; expressed as gallons per capita per day (gpcd).
Percolation	The gradual downward flow of water from the surface of the earth into the soil.
Point source	Pollutant loads discharged at a specific location from pipes, outfalls, and conveyance channels from either municipal wastewater treatment plants or industrial waste treatment facilities. Point sources also include pollutant loads contributed by urban stormwater systems or tributaries to the main receiving water stream or river.
Pollutant	A contaminant in a concentration or amount that adversely alters the physical, chemical, or biological properties of a natural environment. The term includes pathogens, toxic metals, carcinogens, oxygen demanding substances, or other harmful substances.
Porous Pavement	A special type of pavement that allows rain to pass through it and infiltrate into the underlying soil, thereby reducing runoff from the site and surrounding areas.
Potable Reuse	A general term for the use of recycled water to augment drinking water supplies. Potable reuse, which covers both indirect and direct potable reuse, involves various forms of treatment options.
Potable Water	Water that is satisfactory for drinking and cooking.

Public-Supply	Municipal wastewater treatment plant owned and operated by a (POTW) public governmental entity such as a town or city.
Pumping Station	Mechanical devices installed in or water systems or other liquid carrying pipelines that move the liquids to a higher level.
Rain Garden	A rain garden is a depressed area of the ground planted with vegetation, allowing runoff from impervious surfaces such as parking lots and roofs the opportunity to be collected and infiltrated into the groundwater supply or returned to the atmosphere through evaporation and evapotranspiration.
Reach (of a river)	A linear or longitudinal section of a stream or river defined by the upstream and downstream locations of lower stream order tributaries flowing into a higher stream.
Receiving Waters	Creeks, streams, rivers, lakes, estuaries, groundwater formations, or other bodies of water into which surface water and/or treated or untreated wastewater are discharged, either naturally or in man-made.
Recharge	The process by which precipitation seeps into the groundwater.
Recycled Water	Treated wastewater that meets appropriate water quality requirements and is reused for a specific purpose.
Retention Basin	Surface or underground basin that captures flow and retain it until water infiltrates into the soil.
Reverse Osmosis (RO)	A method of removing salts or other impurities from water by forcing water through a semi-permeable membrane.
Reverse Osmosis Reject Water	Waste water released from the reverse osmosis process.
Runoff	The excess portion of precipitation that does not infiltrate into the ground, but “runs off” and reaches a stream, water body or storm drain.
Secondary Treatment	Biological or chemical treatment processes added to a secondary treatment plant including a conventional activated sludge to increase the removal of solids and BOD. Typical removal rates for advanced secondary plants are on the order of 90% removal of solids and BOD.
Sewer	A system of underground pipes that collect and deliver wastewater to treatment facilities or streams.
Stakeholders	Individuals and organizations that are involved in or may be affected by a proposed action, such as construction and operation of a water recycling project.

Title 22 Treatment (Title 22)	A method of tertiary wastewater treatment approved by DHS for many water reuse applications. Title 22, Division 4 of the California Code of Regulations, outlines the level of treatment required for allowable uses for recycled water, including irrigation, firefighting, residential landscape watering, industrial uses, food crop production, construction activities, commercial laundries, road cleaning, recreational purposes, decorative fountains, and ponds.
Total Maximum Daily Load (TMDL)	The sum of the individual waste load allocations and load allocations. A margin of safety is included with the two types of allocations so that any additional loading, regardless of source, would not produce a violation of water quality standards.
Tributary	A lower order stream compared to a receiving waterbody. “Tributary to” indicates the largest stream into which the reported stream or tributary flows.
Turbidity	Measure of the amount of suspended material in water.
Ultraviolet Treatment (UV)	The use of ultraviolet light for disinfection.
Urban Runoff	Water derived from surface runoff or shallow groundwater discharge from urban land use areas.
Urban Water Cycle	The Water Cycle in an urban environment; includes the consequences of increased development. More development and more concrete means less infiltration of rainwater into the soil, and more runoff.
Wastewater	Usually refers to effluent from an industrial or municipal sewage treatment plant.
Wastewater Treatment	Wastewater treatment process that includes combinations of physical and chemical operation units designed to remove nutrients, toxic substances, or other pollutants. Advanced, or tertiary, treatment processes treat effluent from secondary treatment facilities using processes such as nutrient removal (nitrification, denitrification), filtration, or carbon adsorption. Tertiary treatment plants typically achieve about 95% removal of solids and BOD in addition to removal of nutrients or other materials.
Water Cycle	The circuit of water movement from the oceans to the atmosphere and to the Earth and return to the atmosphere through various stages or processes such as precipitation, interception, runoff, infiltration, percolation, storage, evaporation, and transportation.
Water quality	A term used to describe the chemical, physical, and biological characteristics of water, usually in respect to its suitability for a particular purpose.
Water Reclamation	(1) The treatment of water of impaired quality, including brackish water and seawater, to produce a water of suitable quality for the intended use. (2) A term synonymous with water recycling.

<p>Water Reclamation Plant</p>	<p>A facility designed to receive the wastewater from domestic sources and to remove materials that damage water quality and threaten public health and safety when discharged into receiving streams or bodies of water. The substances removed are classified into four basic areas:</p> <ol style="list-style-type: none"> 1. greases and fats; 2. solids from human waste and other sources; 3. dissolved pollutants from human waste and decomposition products; and 4. dangerous microorganisms. <p>Most facilities employ a combination of mechanical removal steps and bacterial decomposition to achieve the desired results. Chlorine is often added to discharges from the plants to reduce the danger of spreading disease by the release of pathogenic bacteria.</p>
<p>Water Recycling</p>	<p>The process of treating wastewater for beneficial use, storing and distributing recycled water, and the actual use of recycled water.</p>
<p>Watershed</p>	<p>The area or region of land draining into a common outlet such as a river or body of water. Synonymous with river basin or drainage basin.</p>

EXECUTIVE SUMMARY

ES.1 PLAN PURPOSE

The purpose of the One Water LA 2040 Plan (Plan) is to increase sustainable water management for the City of Los Angeles (City). The City launched One Water LA with two primary goals:

1. Develop a vision and implementation strategy to more sustainably and cost-effectively manage water.
2. Identify ways for City departments and regional agencies to integrate their water management strategies.

Los Angeles Sanitation (LASAN) and the Los Angeles Department of Water and Power (LADWP) led the Plan's development, partnering with other City departments, regional agencies, academia, the business community, and other stakeholders.

The Plan provides a comprehensive strategy for managing water in a more integrated, collaborative, and sustainable way through new project, program, and policy opportunities. The Implementation Strategy provides a roadmap to make the One Water LA Vision a reality. Additional water projects, programs, or policies that are the sole responsibility of one agency, including LADWP's aqueduct or groundwater remediation project, are contained in each agency's appropriate plans.

ES.2 PLAN BACKGROUND

In 1999, the City started preparing its first Water Integrated Resources Plan (Water IRP). In 2006, the Water IRP was completed with a planning horizon of year 2020. Since then, the City's water situation has changed. Some of the most prominent changes have been triggered by the severe statewide drought that began in 2012. Today, it faces sustainability challenges, new stormwater quality regulations, and the threats of climate change. In response to these challenges and to help achieve water sustainability, the City initiated the Plan, which builds on the success of the Water IRP and extends the planning horizon to year 2040.

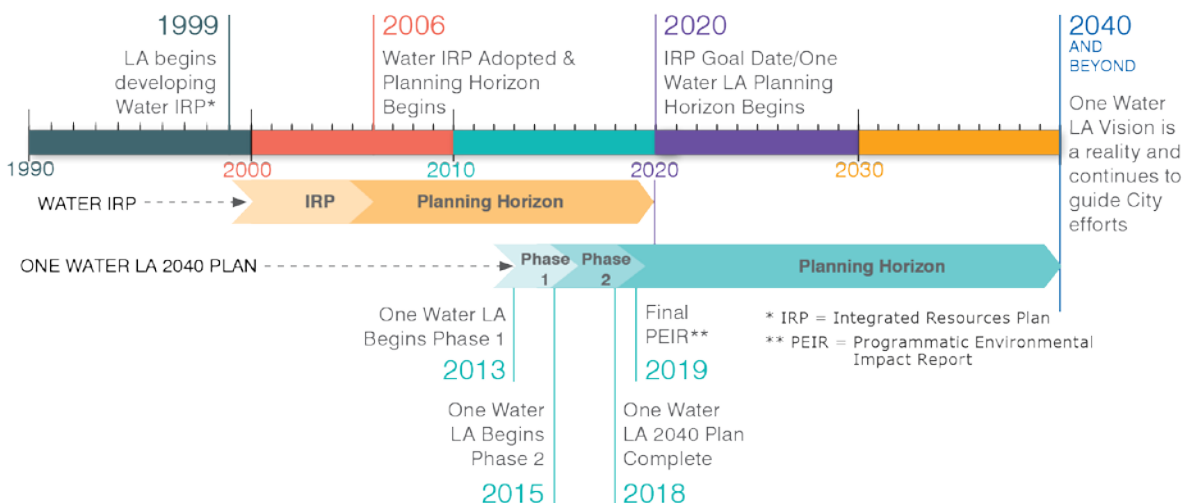

ES.3 ONE WATER LA VISION, OBJECTIVES, AND GUIDING PRINCIPLES

The One Water LA Vision Statement was developed with extensive input from Stakeholders and the One Water LA Advisory Group to guide the One Water LA 2040 Plan development through the planning horizon to the year 2040. The Vision Statement defines the One Water LA Plan's overall purpose and describes the City's aspirations, in broad terms, for accomplishing it, setting the course for future decisions and actions. The One Water LA Vision Statement is as follows:

One Water LA is a collaborative approach to develop an integrated framework for managing the City's water resources, watersheds, and water facilities in an environmentally, economically, and socially beneficial manner.

One Water LA will lead to smarter land use practices, healthier watersheds, greater reliability of our water and wastewater systems, increased efficiency and operation of our utilities, enhanced livable communities, resilience against climate change, and protection of public health.

Collaborating with the Steering Committee, Advisory Group, and Stakeholders (described in ES.4.3), the City developed the One Water LA Guiding Principles Report, which defines 7 Objectives and 38 Guiding Principles. The Guiding Principles Report is included in Volume 9 of the Plan. The seven objectives of One Water LA are as follows:

1. **Integrate management of water resources and policies** by increasing coordination and cooperation between City departments, partners, and stakeholders.
2. **Balance environmental, economic, and societal goals** by implementing affordable and equitable projects and programs that provide multiple benefits to all communities.
3. **Improve health of local watersheds** by reducing impervious cover, restoring ecosystems, decreasing pollutants in our waterways, and mitigating local flood impacts.
4. **Improve local water supply reliability** by increasing capture of stormwater, conserving potable water, and expanding water reuse.
5. **Implement, monitor, and maintain a reliable wastewater system** that safely conveys, treats, and reuses wastewater, while also reducing sewer overflows and odors.
6. **Increase climate resilience** by planning for climate change mitigation and adaptation strategies in all City actions.
7. **Increase community awareness and advocacy for sustainable water** by active engagement, public outreach, and education.

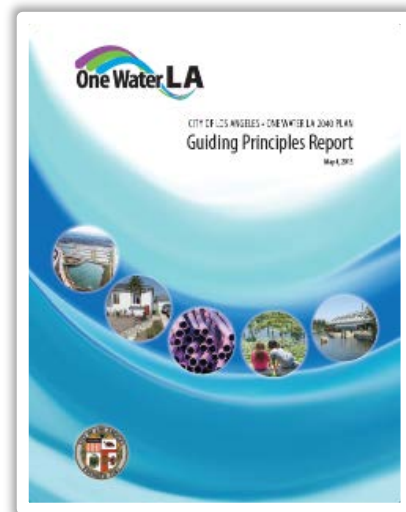

Each Objective is supported by multiple Guiding Principles, which provide specific direction on the desired actions to take to accomplish the Objectives. A complete list of Guiding Principles is provided in Chapter 1.

ES.4 PLAN ELEMENTS AND DEVELOPMENT PROCESS

The One Water LA 2040 Plan was developed in two phases and led by dedicated representatives from both LASAN and LADWP. It was shaped by input received from other City departments, regional agencies, the advisory group, and a large stakeholder group, representing various interests.

Phase 1 defined the Vision, Objectives, and Guiding Principles through an extensive stakeholder-driven process documented in the Guiding Principles Report.

Phase 2 consisted of various elements that combined the findings of strategic planning, analyses, and studies to develop the One Water LA 2040 Plan.

ES.4.1 Leveraging Existing Planning Efforts

One Water LA connects plans, ideas, and people to create more integrated and fiscally responsible water management solutions. By looking at the entire water picture, the City and its partners can create more efficient projects that maximize resources and minimize cost. The City is committed to pursuing projects with multiple benefits, combining financial resources, and identifying funding opportunities to make One Water LA a reality.

One Water LA integrates information developed for numerous existing plans and studies, such as:

- 2006 Water Integrated Resources Plan (IRP).
- 2015 Urban Water Management Plan (UWMP).
- 2015 Stormwater Capture Master Plan (SCMP).
- 2015 Enhanced Watershed Management Plans (EWMP) representing each of LA's five watersheds.



The One Water LA 2040 Plan consists of many elements that form the foundation of the Plan Recommendations and Implementation Strategy



One Water LA leverages many existing plans and studies

- 2015 LA Basin Stormwater Conservation Study.
- 2015 Sustainable City pLAN.

Chapter 1 describes these plans and studies in greater detail. Information and elements from existing plans that present opportunities for integration were incorporated.

ES.4.2 Water Management Goals

LADWP's 2015 UWMP is the City's long-term water resource plan for developing and managing the City's water supply resources. The UWMP evaluated four key areas to improve local water supply reliability and to reduce the City's reliance on imported water. Specifically, the UWMP seeks to increase local groundwater, recycled water, and stormwater, focusing on supplementing them with increased water conservation programs throughout the City.

The Plan supports the UWMP by identifying opportunities for collaboration to create integrated water management that helps achieve these goals.

The future water supply strategies established in LADWP's 2015 UWMP are designed to meet the Sustainable City pLAN goals, which are summarized in the graphic below.

A few examples of the Sustainable City pLAN goals One Water LA supports

Stormwater Quality: Improve beach water quality grade-point average (GPA) to:



3.9 (dry)
3.2 (wet)

2025



4.0 (dry)
3.5 (wet)

2035

 **Reduce the purchase of imported water by 50%**

50% 2025

150,000 AFY  **Capture 150,000 acre-feet per year of stormwater**

2035

50%  **Source 50% of water locally**

2035

LADWP's 2015 UWMP provides a strategy for meeting the local water supply goals under normal year conditions and most dry year conditions. The One Water LA 2040 Plan evaluated numerous new

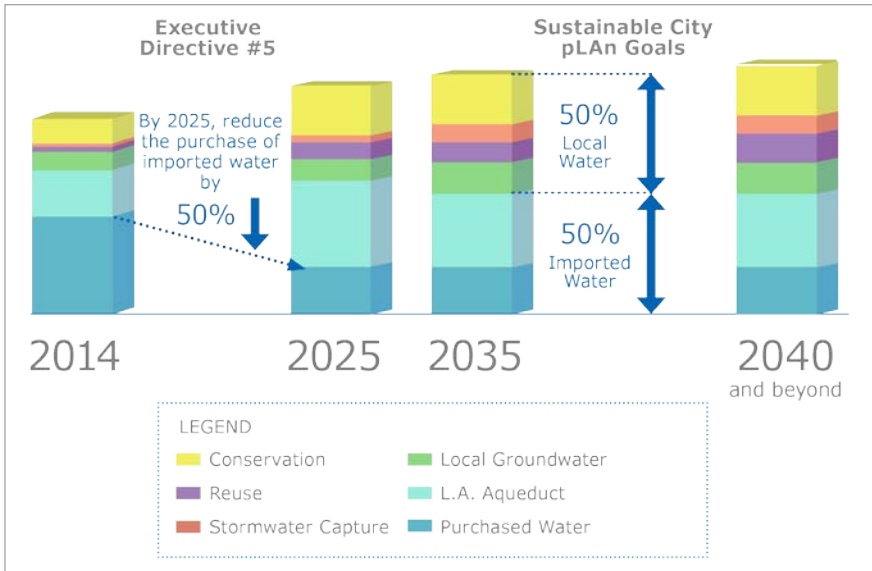

project ideas to support meeting these goals during prolonged dry year conditions. To meet stormwater capture and quality goals, a combination of regional and distributed stormwater projects, programs, and policies are recommended.

To support the Sustainable City pLAN water supply reliability and stormwater capture and quality goals, the One Water LA 2040 Plan recommends additional projects requiring partnerships among multiple City departments and regional agencies.

ES.4.3 Collaboration and Stakeholder Engagement

One of the Plan's unique elements is the extensive cooperation and collaboration at many different levels within the City family. To open channels of communication and build collaboration, all departments engaged in water management were involved in the planning process.



Development of the One Water LA 2040 Plan involves extensive cooperation and engagement from a variety of groups and committees.

The One Water LA 2040 Plan is more than just a planning document – it's the product of many people throughout the city working together to change the way water is managed. By bringing together all parties in the planning stage, a collaborative process was developed that will continue through the Plan's implementation and beyond.

To integrate the management of water-related projects, programs, and policies, One Water LA established a variety of groups and engagement activities to increase coordination and cooperation among City departments, partners, and stakeholders. The various engagement groups are described in more detail below.



One Water LA Steering Committee: The steering committee represents 14 City departments and 6 regional agencies shown in the graphic below that collaborated to:

- Develop the Vision Statement, Objectives, and Guiding Principles with stakeholders.
- Identify water-related project integration opportunities.
- Develop policies to integrate and streamline water-related resource management.



Inter-departmental/agency focus meetings: LASAN and LADWP staff met with individual City departments and regional agencies to discuss potential water-related integration opportunities.



One Water LA Stakeholder Group:

The stakeholder group consists of more than 500 stakeholders representing over 200 organizations, including neighborhood councils, non-profits, business and homeowner associations, academia, and others throughout the greater Los Angeles area. Approximately 250 stakeholders actively participate in workshops and meetings.



Stakeholder Advisory Group:

The Advisory Group represents the larger One Water LA stakeholder group in terms of interests, City geography, and past participation in other water-related stakeholder processes. With a smaller, ten-member group, interaction was more frequent and involved more in-depth discussions to guide the Plan's development.

Stakeholders participated in roundtable discussions on future project opportunities and evaluation criteria at a World Café-style stakeholder workshop.

Special Topic Groups:

Five Special Topic Groups were established to facilitate in-depth discussion with a variety of stakeholders for the following key Plan components:

- Stormwater and Runoff Management.
- Funding and Cost-Benefit Analysis.
- Outreach and Communication.
- Partnership, Collaboration, and Innovation.
- Decentralized/On-Site Treatment.



Stakeholders participating in the Funding Special Topic Group gathered and compared funding ideas incorporated into the One Water LA Plan.

The Plan's stakeholder engagement involved various meetings, workshops, and outreach activities, which are briefly listed and described in Chapter 2, while, future implementation committees and continued stakeholder engagement efforts are described in Chapter 10. Meeting materials and workshop presentations are included in Volume 9.

ES.5 PLAN OUTCOMES

The Plan provides a strategic vision and a collaborative approach to integrated water management through year 2040. Key outcomes include:

- Identification of current and future water-related integration opportunities among City departments, regional agencies, and other stakeholders.
- Identification of strategies and concept options to maximize potable reuse opportunities. Concept options are proposed projects that have been evaluated at the conceptual level and will be considered further in the future.
- Identification of strategies and projects to maximize stormwater capture that consider water quality, flood mitigation, and water supply benefits.
- Policy and program recommendations that help achieve the One Water LA Vision and Objectives.
- Identification of funding sources and mechanisms to further implement the projects, programs, and policies recommended in the Plan.
- Increased stakeholder awareness about the City's water challenges, ongoing collaboration activities, and long-term water management strategies to become a more water-resilient city.
- Increased collaboration between various City departments and regional agencies on water-related projects, programs, and policies due to strengthened and new relationships developed during the One Water LA planning process.



LASAN hosted its first annual Earth Day LA on April 23, 2016 to share the importance of water and zero waste.

ES.5.1 Integrated Urban Water Cycle

Within the One Water paradigm, all of the City's water sources are linked through the urban water cycle. In the urban water cycle, rain becomes stormwater, which infiltrates into the groundwater basin or becomes urban runoff. Groundwater is pumped for use as potable water. Once water is used in homes and businesses, it is discharged as wastewater, before being treated and reused as recycled water or discharged to the ocean. The Plan identifies projects, programs, and policies to enhance the City's urban water cycle to increase water recycling and stormwater capture opportunities and minimize losses to the ocean while reducing reliance on purchased imported water.



The City has a vision for its urban water cycle that maximizes opportunities to achieve a sustainable One Water future for all Angelenos, as shown on Figure ES.1. Key long-term initiatives to optimize and enhance the urban water cycle include:

- Increasing stormwater capture and recharge in the aquifers through distributed green infrastructure projects and programs.
- Increasing stormwater capture, treatment, and reuse at parcel, neighborhood, sub-watershed, and regional levels.
- Increasing use of the groundwater basins for storage through new recharge projects.
- Expanding recycled water for irrigation, commercial, industrial, and groundwater recharge uses.
- Balancing the City's water supply needs with environmental needs, such as preserving the LA River ecosystem.
- Exploring potential potable reuse options using advanced treated wastewater at each of the City's four water reclamation plants (WRPs).
- Exploring potential potable reuse opportunities outside of the San Fernando Groundwater Basin through inter-agency partnerships.

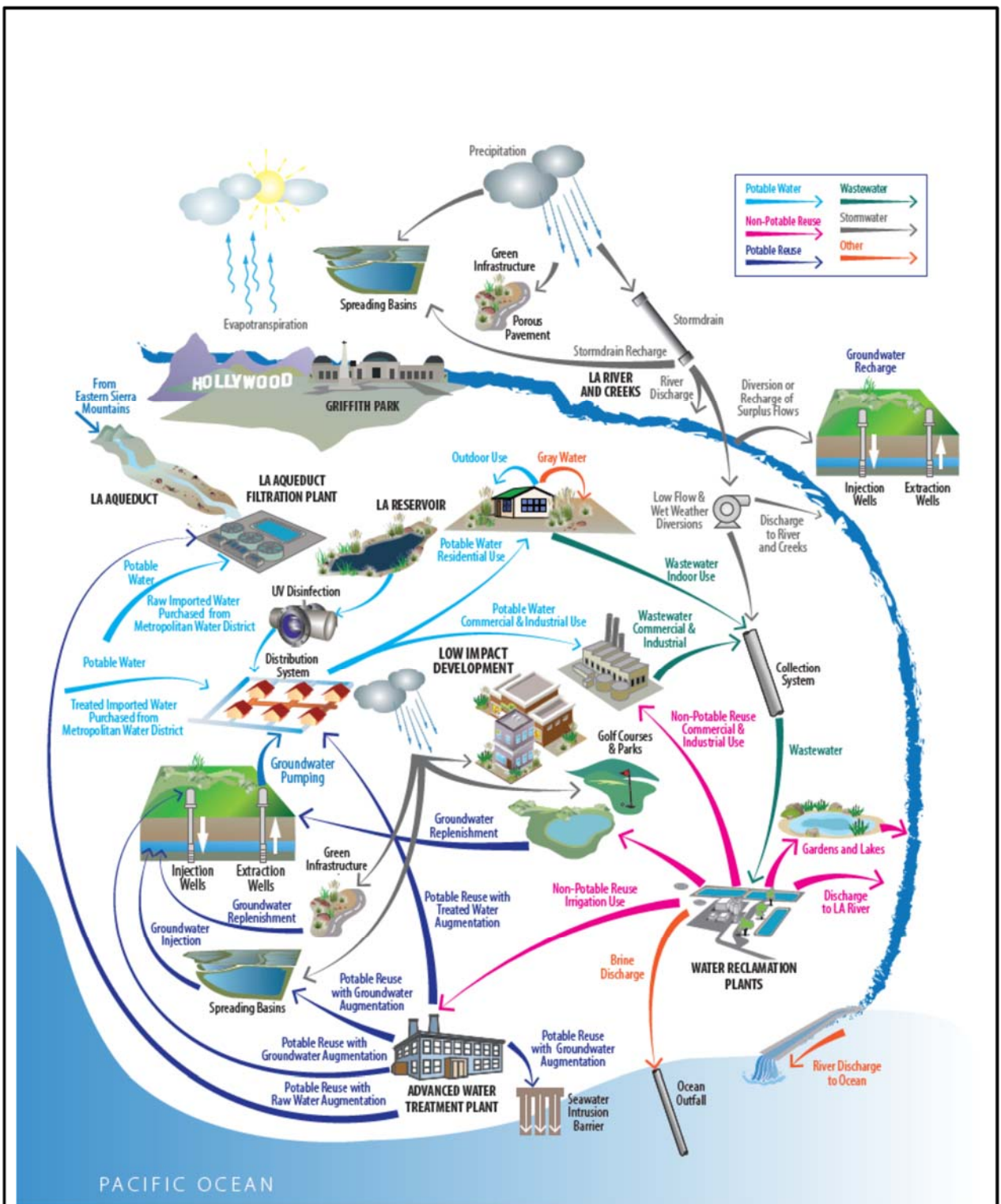

Figure ES.1 - Los Angeles' Future Smart Urban Water Cycle
 One Water LA 2040 Plan
 Summary Report

ES.5.2 Integration Outcomes and Momentum

The One Water LA team has discussed the City's challenges in water integration, project opportunities, and potential partnerships with City departments and regional agencies to establish a better understanding of how water connects projects, programs, and policies. Discussions were, and continue to be held on how water interfaces with each group's projects and programs and how their studies and designs could manage water differently. Through these interactions, many One Water LA partners have had moments of enlightenment, realizing that water is not ancillary, but an integral component of their designs and practices. City departments and regional agencies immediately started implementing planning, pre-design, and design approaches in their policies, projects, and programs. The key successes and outcomes from the One Water LA team's ongoing participation in multiple efforts are summarized in Chapter 1. Specific changes in business practices demonstrate the impact of the One Water LA team's collaborative efforts.

ES.5.3 Planning for a more Resilient Future

LADWP's 2015 Urban Water Management Plan (UWMP) already addresses multiple new strategies in the future smart urban water cycle. The Plan identifies additional integration opportunities that could be implemented by year 2040 and beyond.

The One Water LA 2040 Plan recommendations focus primarily on water-related projects and programs that require multi-departmental and multi-agency coordination and collaboration. The recommendations consist of select projects, programs, and policies developed to further integrate opportunities that help achieve the One Water LA Vision, Objectives, and Guiding Principles.

These plan recommendations were grouped into the following categories, which are described in greater detail in the following Sections:

- Stormwater projects (see Section ES.6).
- Wastewater projects (see Section ES.7).
- Current integration opportunities (see Section ES.8).
- Future integration opportunities (see Section ES.9).
- Policies and programs (see Section ES.10).

ES.6 STORMWATER AND URBAN RUNOFF FACILITIES PLAN

The Stormwater and Urban Runoff Facilities Plan (SWFP) was prepared under the Plan to help City staff, stakeholders, and policymakers better understand the needs of the stormwater infrastructure system over the next 25 years. The SWFP is included in Volume 3 of the Plan, and a comprehensive summary is provided in Chapter 8.

Stormwater and urban runoff facilities are the infrastructure (green and grey) needed to convey or collect wet-weather and dry-weather runoff into, from within, and throughout the city. Collectively, these facilities manage flood risks, meet water quality requirements, recharge the groundwater basins, and provide a local water supply.

ES.6.1 Stormwater and Receiving Water Quality Goals

Stormwater and urban runoff from within the City are subject to many regulations, directives, and policies. To manage these regulations, the City has developed master plans, ordinances, directives, and other documents over the years. These documents help implement these goals and targets at the local level to improve stormwater runoff quality, flood protection, and water supply benefits.

Total Maximum Daily Loads (TMDLs) drive stormwater quality goals, specifying the maximum amount of a pollutant a discharger can discharge into a water body without affecting the designated beneficial uses. These TMDLs also have interim and final compliance milestones. The Stormwater and Urban Runoff Facilities Plan provides guidance to meet the TMDL requirements within the specified timelines.

Currently, 22 TMDLs govern all receiving water bodies within the City. The Stormwater Improvement Program (SIP) projects are grouped and phased according to the various compliance deadlines they must meet and their watershed.



The timeline illustrates the TMDL compliance deadlines by watershed.

ES.6.2 Stormwater Planning Approach

Building from significant previous stormwater infrastructure planning efforts, the Stormwater and Urban Runoff Facilities Plan evaluates various types of studies, plans, projects, and programs. In addition, the plan used a "Three-Legged-Stool" approach to integrate water quality, water supply, and flood risk mitigation where possible.

- Water Quality Improvement** – These projects improve the health of local watersheds by reducing impervious cover, restoring ecosystems, decreasing pollutants in the waterways, and providing environmental and habitat benefits. Stormwater improvement projects intended to improve the quality of a downstream waterbody are typically driven by regulations such as TMDLs and/or 303(d) listings.
- Water Supply Augmentation** – These projects capture runoff to help offset potable water use through direct use projects. They also increase water supply through groundwater augmentation and capture and use wet-weather/dry-weather runoff to offset potable water demand and/or enhance environmental and habitat conditions.
- Flood Risk Mitigation** – These projects protect life and safety and mitigate local flood impacts. Stormwater improvement projects intended to reduce flood risks are typically driven by asset-specific needs, such as whether an asset is located near a known or anticipated area of flooding; insufficient capacity; asset deterioration or expiration of useful life based on age; and known or anticipated impacts from sea level or groundwater rise.



Three-Legged Stool Approach promotes implementation of projects that achieve benefits from these three areas.

Ideally, all projects have some level of flood risk mitigation, water quality improvement, and water supply augmentation, and the SWFP attempts to select projects that achieve benefits in all three areas. Projects were prioritized based on these three benefits, with projects that mitigate flood risks, improve water quality, and augment water supply given the highest priority, followed by projects that achieve only two of these three benefits, etc. In addition to prioritizing a project based on these three benefits, projects that meet stormwater quality deadlines were also prioritized. The majority of projects (95 percent) provide two or more of these benefits. Projects that provide all three benefits also represent the majority (59 percent) of the total SIP cost. In addition to these three benefits, the City recognizes the multitude of quantitative and qualitative benefits that stormwater projects provide.

Implementing an integrated, multi-benefit approach to stormwater management is expected to lower costs in the long run for the following reasons:

- The cost of one multiple-benefit project is anticipated to be less than the cost of multiple single-benefit projects that achieve the same goals.
- Fewer projects may be necessary to meet local goals, leading to long-term savings.



Stormwater project can provide a wide range of benefits to make Los Angeles a more resilient city.

ES.6.3 Stormwater Improvement Program

To help the City meet its stormwater and urban runoff management needs over the next 25 years, a comprehensive Stormwater Improvement Program (SIP) was developed. Building on previous planning efforts, the recommended SIP includes approximately 1,142 stormwater projects and programs that will help meet water quality regulations, address flooding risks, and provide water supply benefits by recharging groundwater in underlying aquifers or offsetting potable water use. The stormwater recommendations are condensed into a comprehensive database and organized into various project categories, as described below.

ES.6.3.1 Stormwater Project Database

As a key component to the stormwater management aspect of the One Water LA 2040 Plan, a single database of planned and potential projects was developed to compile ongoing stormwater management efforts from multiple agencies operating within the City. The database is foundational to the development of the SIP as it provides a common platform to evaluate all projects against standardized stormwater project selection criteria. The database includes approximately 1,201 regional and distributed stormwater project opportunities of which 1,142 are located within the City. Note, the total quantity and estimated cost of stormwater projects provided in Volume 1 is based on the 1,142 projects within the City only.

The projects were aggregated from the EWMPs, LADWP's SCMP, remaining Prop O projects, LASAN's five-year CIP projects, and LA County's projects. The entire stormwater project list is included in Appendix D.

To align project phasing with TMDL milestones, the stormwater projects were organized according to each of the City's four major watersheds. As shown on Figure ES.2, the major watersheds are:

- Upper LA River.
- Ballona Creek.
- Dominguez Channel.
- Santa Monica Bay/Marina Del Rey. (Due to the Marina Del Rey Watershed's size and location, the Plan combined it with the Santa Monica Bay Watershed.)

The vast majority of the projects in the stormwater database are Green Streets projects, which are critical to the City's stormwater management system since they allow distributed stormwater projects to be further developed. Green Streets recommendations were organized in groups called "blocks" (Blocks A, B, C, and D) to help select project phasing to meet each watershed's TMDL milestones. A total of 445 Green Streets block programs were developed, representing a combined length of approximately 225 miles of Green Streets.

ES.6.3.2 Stormwater Project Categories

The stormwater database includes projects that provide flood risk mitigation, water quality improvement, and/or water supply augmentation benefits throughout the city. These projects are also grouped in the following three project categories:

- **Distributed Green Infrastructure Projects –** Green infrastructure consists of both nature-based and mechanical systems designed to mimic natural processes. These projects retain, infiltrate, or treat runoff, offering multiple benefits such as flood protection, water quality improvement, and water supply benefits.

Distributed green infrastructure projects include site-scale detention, porous pavement, infiltration trenches, drywells, cisterns, nature-inspired systems (e.g., bioretention/biofilter cells, bioswales, and green roofs), flow-through BMPs (e.g., downspout filters, flow-through planters, and proprietary units), and source controls (e.g., catch basin retrofits, proprietary units). Examples of distributed green infrastructure projects in the City are Elmer Paseo, Broadway Neighborhood Stormwater Greenway, Woodman Avenue Greenway, Ed P. Reyes Parkway, and Manchester Neighborhood greenway.

Parcel-based solutions are also an important part of the distributed green infrastructure program to help the City accomplish its stormwater goals. Many of the Plan's recommended policies, summarized in Table ES.2 (see page 46) are intended to increase implementation and improve the performance of distributed BMPs.



Elmer Paseo is one the City's "Green Alley" projects, capturing stormwater for infiltration and recharge of groundwater.

- Regional Green Infrastructure Projects –** Regional green infrastructure projects include retention/infiltration, capture-storage-use systems, nature-inspired flow-through treatment wetlands, and low-flow diversions to other regional green infrastructure projects. Examples of regional green infrastructure projects in the City are Hansen Spreading Grounds, Penmar Park, Rory M. Shaw, South LA Wetlands Park, Machado Lake Wetlands park, Harbor City Greenway also known as Wilmington Drain.



The Groundwater Replenishment Project will recharge up to 30,000 acre-feet of purified recycled water per year into the San Fernando groundwater basin at the Hansen Spreading Grounds (shown) and Pacoima Spreading Grounds for percolation.

- Regional Grey Infrastructure Projects –** Grey infrastructure is stormwater conveyance and detention infrastructure historically designed to provide flood protection by collecting runoff, detaining collected runoff to attenuate peak discharge rates when necessary, and ultimately conveying runoff to downstream receiving waters and away from City property. These receiving waters include oceans, reservoirs, and groundwater aquifers. Examples of grey infrastructure include storm drains and open channels, outfalls, Los Angeles Department of Transportation (LADOT) street profiles (road curbs, gutters, and catch basins), pump stations, low-flow diversion structures that divert flows to the sewer system, debris basins, reservoirs, and dams. Examples of regional grey infrastructure projects in the City are the LA Zoo Pumping Plant Facility and the Venice Pumping Plant Facility.



Venice Low Flow Diversion Pump Station

Climate resilience infrastructure projects are also included in the Regional Grey project category. Examples of these projects are the Venice LFD Climate Resilience Retrofit and Tuxford Pumping Plant No.614 Low Flow Diversion Climate Resilience Retrofit. Detailed information on the climate risk assessment for stormwater infrastructure, and the associated recommendations can be found in Volume 5 of the Plan.

Upper Los Angeles River Watershed

- 434 Distributed Green Infrastructure projects (\$1007 M)
- 93 Regional Green Infrastructure projects (\$1894 M)
- 301 Regional Gray Infrastructure projects (\$490 M)
- 69.8 miles of Green Streets
- Total = \$3,391 M**

Ballona Creek Watershed

- 113 Distributed Green Infrastructure projects (\$1001 M)
- 83 Regional Green Infrastructure projects (\$326 M)
- 5 Regional Gray Infrastructure projects (\$43 M)
- 61.3 miles of Green Streets
- Total = \$1,370 M**

Santa Monica Bay - Marina Del Rey Watershed

- 41 Distributed Green Infrastructure projects (\$383 M)
- 15 Regional Green Infrastructure projects (\$124 M)
- 8 Regional Gray Infrastructure projects (\$23 M)
- 14.4 miles of Green Streets
- Total = \$530 M**

Dominguez Channel and LA Harbor Watershed

- 31 Distributed Green Infrastructure projects (\$166 M)
- 6 Regional Green Infrastructure projects (\$108 M)
- 12 Regional Gray Infrastructure projects (\$26 M)
- 8.9 miles of Green Streets
- Total = \$300 M**

Legend

- Existing Water Reclamation Plant (WRP)
 - City of Los Angeles
 - Watershed Boundary
 - Marina Del Rey
 - Los Angeles River
 - Ballona Creek
 - Santa Monica Bay
 - Dominguez Channel and LA Harbor
- Bold text = Priority A**
See Appendix D per detailed priority listing.

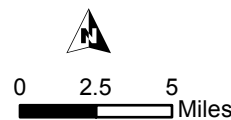

Hillshade Source: CalAtlas
<http://www.atlas.ca.gov>

Figure ES.2
Summary of Stormwater
Projects by Watershed
One Water LA 2040 Plan
Summary Report

ES.6.4 Stormwater and Urban Runoff Facilities Plan Recommendations

To develop the SIP, results from multiple watershed planning efforts from both public and private agencies within the City's jurisdiction were compiled. Projects proposed within the City's jurisdiction from previous watershed planning efforts were gathered and evaluated using the "three-legged stool" evaluation criteria. Only City-involved projects (either as lead agency or partnering with other agencies) were included in the SIP.

Estimated costs are shown on Figure ES.2 according to their watershed. Stormwater projects are summarized on Figure ES.3 according to their project type relative to their respective watershed. As shown, most projects are located in the Upper LA River Watershed, followed by the Ballona Creek Watershed.

The estimated capital cost distribution of stormwater projects, organized by project type, is shown on Figure ES.3. As shown, the SIP's total estimated capital cost is \$5.6 billion, with the vast majority (90 percent) allocated to regional and distributed green infrastructure. Only 10 percent of the SIP is allocated to regional grey stormwater infrastructure projects.

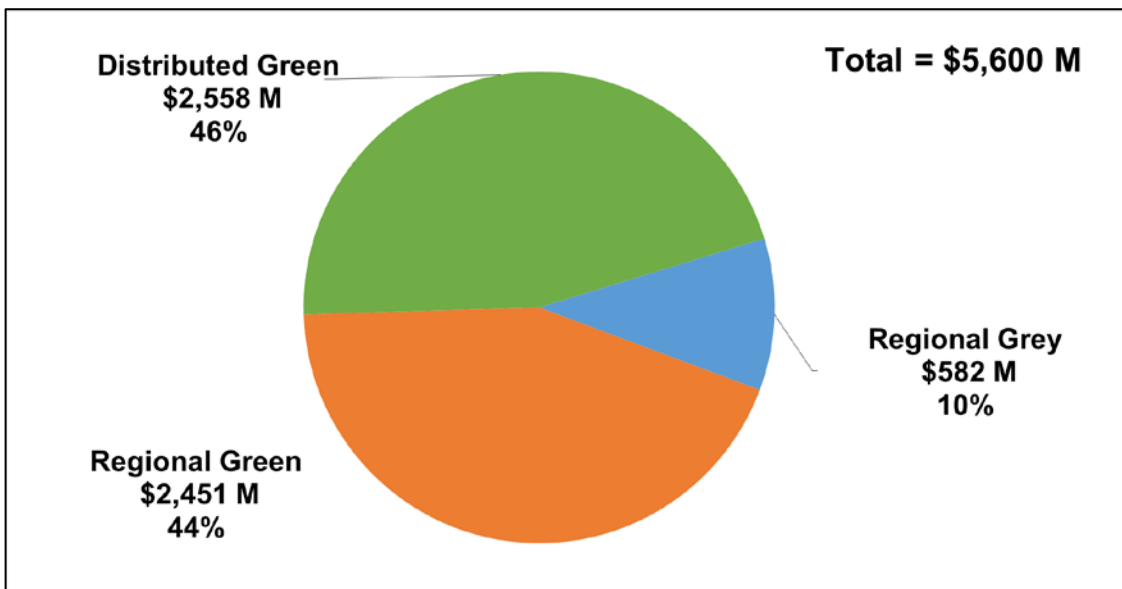

Figure ES.3 Estimated Cost Distribution of Stormwater Projects by Project Type

Green Streets projects make up the vast majority of the 1,142 projects included in the SIP. Green infrastructure also represents approximately 90 percent of the estimated cost. More details on the proposed SIP are included in Chapter 8.

ES.6.4.1 Stormwater Related Policy Recommendations

In addition to the stormwater projects included in the database and SIP, parcel-based solutions are an important part of the distributed green infrastructure program. Many of the Plan's recommended policies are intended to increase the likelihood of implementation and improve the performance of distributed BMPs.

One Water LA policies outline strategies to simplify processes and remove barriers to install green infrastructure, develop incentives and property owner recognition programs, increase training and education, develop maintenance protocols, and increase partnership opportunities with non-profit partners. One of the recommended policies (#5) is to develop robust stormwater pollution source control education measures to increase awareness and public participation. Stakeholders also identified specific recommended action items (AC1 and AC6) related to source control. These policies are summarized in Table ES.2 (see page 46). A full list of the policies and action items can be found in Chapter 9 and Appendix E.

ES.7 WASTEWATER FACILITIES PLAN

The Wastewater Facilities Plan (WWFP) guides LASAN's decisions on implementing system improvements to its wastewater collection and treatment facilities. The WWFP provides the underlying documentation to make informed decisions on investments to repair, replace, or enhance existing facilities and construct new conveyance or treatment facilities through year 2040.

The WWFP is anticipated to be updated in approximately 10 years to incorporate system modifications and changes in flow conditions, regulatory framework, and overall vision for wastewater system operations and water reuse. The WWFP is included in Volume 2 of the Plan, and a comprehensive summary is provided in Chapter 7.

ES.7.1 Potable and Non-Potable Reuse

Water reuse plays an important role in meeting the Mayor's water supply goal of sourcing 50 percent of the City's water supply locally by year 2035. The WWFP recommends ways for each WRP to best reuse water and achieve environmental stewardship. Among the water reuse opportunities explored are:

- Non-potable reuse (NPR).
- Potable reuse with groundwater augmentation.
- Potable reuse with raw water augmentation.
- Potable reuse with treated water augmentation.

A trigger-based capital improvement plan (CIP) was developed for both the WWFP and the overall One Water LA Implementation Strategy to help the City navigate the wide range of future water recycling opportunities. With this approach, the City can adjust the implementation phasing and decisions based on future circumstances, such as changes in wastewater flows, regulatory, institutional, and other conditions.



Expanding the City's non-potable water distribution system is one of many water recycling opportunities evaluated in the Plan.

ES.7.2 Water Reclamation Plants

The WWFP study area coincides with the City's wastewater system service area. Within the wastewater system service area, the City owns and operates four WRPs that serve as a source for non-potable and potable reuse opportunities.

The locations of the WRPs and the seven major sewersheds are shown on Figure ES.4. The two inland water reclamation plants, Donald C. Tillman Water Reclamation Plant (DCTWRP) and Los Angeles-Glendale Water Reclamation Plant (LAGWRP), discharge solids and bypass flows to the Hyperion Water Reclamation Plant (HWRP). Treated flows that are not reused are ultimately discharged to the Pacific Ocean.

Based on the design capacities and the projected future flows of each plant through year 2040, all existing WRPs were confirmed to have sufficient capacity to manage the wastewater flows. Nonetheless, advanced treatment facilities would need to be constructed to maximize the reuse opportunities at each plant.

ES.7.3 Wastewater System Planning Approach

The WWFP analyzed the treatment plant modifications needed for potential potable or non-potable reuse strategies included in the future integration opportunities evaluation (see Section ES.9). This analysis involved preliminary sizing of treatment process modifications, locating the processes, identifying conveyance needs, and making preliminary cost estimates.

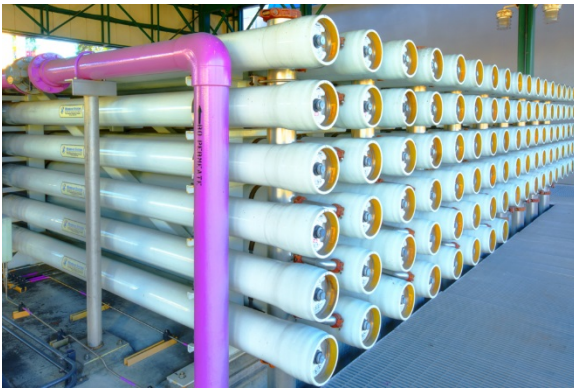

Water is forced through reverse osmosis membranes to remove salt, dissolved chemicals, and viruses (photo from TIWRP).

As shown on Figure ES.7 (see page 34), 16 recycled water concept options were considered for the future integration opportunities evaluation to increase local supply availability and achieve water quality objectives. These options involve various types of water reuse from any of the four water reclamation plants (WRPs), as well as flow-management strategies to increase influent flows to the plants to maximize water recycling opportunities.

The WWFP provides a phased list of recommendations for each WRP. The WWFP also describes the existing wastewater collection system and evaluates potential future WRPs, on-site treatment, and solids handling facility needs. All recommendations in the WWFP were included in a phased wastewater facilities plan capital improvement program (WWFP CIP).

ES.7.4 Wastewater System Recommendations by Plant

The wastewater system and water recycling improvements combined in the comprehensive WWFP CIP can be grouped into the following project categories:

- Capital projects from LASAN's Wastewater Capital Improvement Plan (WCIP).
- Rehabilitation and replacement (R&R) projects from the WCIP.
- Wastewater conveyance projects from the conveyance capacity analysis.
- Climate resiliency projects identified from a separate climate risk assessment study conducted for the Plan (see Volume 6).
- Projected capital and R&R projects beyond the WCIP horizon to year 2040.
- Treatment modifications to accommodate future concept options identified in the future integration opportunities analysis.

A summary of the planned and potential WWFP CIP improvements for each of the City's four WRPs and the collection systems are shown on Figure ES.4. Collectively, these wastewater improvement projects are sized to address existing deficiencies and meet future system needs.

Many of these concept options identified in the future integration opportunities analysis depend on certain triggers, such as regulatory conditions or institutional arrangements, and thus require more detailed feasibility studies. To provide Plan recommendations that can adjust to future changing conditions, a trigger-based implementation strategy was developed for each of the four WRPs. The options identified as Priority A for each WRP coincide with those in the preferred portfolio described in Section ES.9. A detailed discussion of the various triggers and prioritization of the concept options is included in Chapter 9 of Volume 1 and briefly summarized below for each plant.

Donald C. Tillman WRP

WWFP CIP

- 23 Capital Projects from WCIP (\$155 M)
- 8 R&R Projects from WCIP (\$10 M)
- 2 Climate Resiliency Projects (\$12 M)
- Projected Capital Projects (\$240 M)
- Projected R&R Projects (\$200 M)

Total without Future Concepts = \$618 M*

Future Concepts (Priority A,B, C and Other)

- 7) Upper Los Angeles River to DCTWRP
- 9) DCTWRP to San Fernando Basin Injection Wells
- 15) DCTWRP to Los Angeles Aqueduct Filtration Plant**
- 16) DCTWRP to LADWP Distribution System
- 22) East-West Valley Interceptor Sewer**
- 26) Japanese Garden and Sepulveda Basin Lakes Recirculation

LA-Glendale WRP

WWFP CIP

- 2 Capital Projects from WCIP (\$18 M)
- 18 R&R Projects from WCIP (\$56 M)
- 3 Climate Resiliency Projects (\$14 M)
- Projected Capital Projects (\$119 M)
- Projected R&R Projects (\$20 M)

Total without Future Concepts = \$227 M*

Future Concepts (Priority A,B, C and Other)

- 17) LAGWRP to Headworks Reservoir**
- 23) Increase Recycled Water Demand beyond 2015 UWMP

Collection System

WWFP CIP

- 15 Capital Projects from WCIP (\$258 M)
- 105 R&R Projects from WCIP (\$468 M)
- 29 Climate Resiliency Projects (\$15 M)

Total = \$741 M*

Hyperion WRP

WWFP CIP

- 7 Capital Projects from WCIP (\$51 M)
- 37 R&R Projects from WCIP (\$170 M)
- 1 Climate Resiliency Project (\$1 M)
- Projected Capital Projects (\$920 M)
- Projected R&R Projects (\$360 M)

Total without Future Concepts = \$1,501 M*

Future Concepts (Priority A,B,C and Other)

- 10) HWRP to West Coast Basin Injection Wells
- 11) HWRP to Central Basin Injection Wells
- 13) MBR at HWRP to Regional System**
- 14) HWRP to San Fernando Basin Injection Wells
- 18) HWRP to LADWP Distribution System
- 19) HWRP to Headworks Reservoir
- 20) HWRP to Los Angeles Aqueduct Filtration Plant

Terminal Island WRP

WWFP CIP

- 10 Capital Projects from WCIP (\$35 M)
- 18 R&R Projects from WCIP (\$76 M)
- 2 Climate Resiliency Projects (\$14 M)
- Projected Capital Projects (\$140 M)
- Projected R&R Projects (\$38 M)

Total without Future Concepts = \$303 M*

*** Any differences in sum or in comparison to Volume 2 are due to rounding**

Legend

Existing Water Reclamation Plant (WRP)

City of Los Angeles

Sewersheds

Bold Text = Priority A / Preferred Portfolio
See Appendix C for detailed priority listing

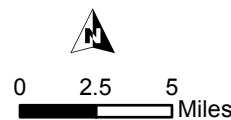

Hillshade Source: CalAtlas
<http://www.atlas.ca.gov>

Figure ES.4
Summary of Wastewater Projects by WRP
One Water LA 2040 Plan
Summary Report

ES.7.4.1 Hyperion Water Reclamation Plant

As shown on Figure ES.4, the WWFP's CIP includes 48 projects with a combined estimated cost of \$1,501 million for the HWRP. Seven concept options were also identified for HWRP. The top four most-beneficial concept options to maximize water recycling from the HWRP, in order of priority, are as follows:

- **Priority A: Concept Option #13** – MBR at HWRP to regional system.
- **Priority B: Concept Option #18** – Potable reuse with treated water augmentation from HWRP to distribution system.
- **Priority C-1: Concept Option #10** – Potable reuse with groundwater augmentation in West Coast Basin
- **Priority C-2: Concept Option #11** – Potable reuse with groundwater augmentation in Central Basin.

The most critical trigger to implement the Priority A Concept Option #13 (Potable reuse from HWRP to regional system) is establishing an institutional agreement with a regional project partner, such as Metropolitan Water District of Southern California (MWD), the Water Replenishment District (WRD), Los Angeles County Sanitation Districts (LACSD), and/or West Basin Municipal Water District (WBMWD). If such an agreement does not materialize, the Priority B and C options should be considered.

The most critical trigger for the Priority B Concept Option #18 is adopting potable reuse with treated water augmentation regulations that would allow for this type of water reuse practice. If the potable regulations are not adopted within the desired timeframe, or the City prefers a more conventional form of water reuse, the third-best potable reuse options from the HWRP are Concept Options #10 and #11. These options consist of groundwater augmentation in the West Coast Basin and Central Basin, respectively. Both options require an institutional agreement with the Water Replenishment District (WRD), which acts as the Watermaster of both groundwater basins. The capacities identified for these concept options can be modified as long as the combined capacity does not exceed the estimated recycled water availability of 95,000 acre-feet per year (AFY) by year 2040.



The City is assessing a wide variety of options to maximize recycling through regional collaboration and partnerships at Hyperion, the City's largest Water Reclamation Plant.

ES.7.4.2 Donald C. Tillman Water Reclamation Plant

As shown on Figure ES.4, the WWFP's CIP includes 36 projects with a combined estimated cost of \$618 million for the DCTWRP. Six concept options were also identified for DCTWRP. The top three most-beneficial concept options to maximize water recycling from DCTWRP are as follows, in order of priority:

- **Priority A: Concept Option #15** – Potable reuse with raw water augmentation from DCTWRP to the Los Angeles Aqueduct Filtration Plant (LAAFP). This concept also requires implementation of **Concept Option #22** – East-West Valley Interceptor Sewer (EWVIS) or another flow management strategy that increases flows at DCT WRP.
- **Priority B: Concept Option #16** – Potable reuse with treated water augmentation from DCTWRP to distribution system.
- **Priority C: Concept Option #9** – Potable reuse with groundwater Augmentation from DCTWRP to San Fernando Basin Injection Wells.

The most critical trigger for implementing the Priority A Concept Option #15 (Raw water augmentation from DCTWRP to LAAFP) is the ability to increase wastewater flow to DCTWRP, which will in turn increase the potential for recycled water. Because of LADWP's water conservation program's success, wastewater flows have reduced. Furthermore, the recycled water produced at DCTWRP is already accounted for by existing and planned non-potable reuse customers as well as the planned GWR project. For these reasons, the first trigger is a decision to pursue and implement a flow management project, such as the EWVIS or the Japanese Garden & Sepulveda Basin Lakes Recirculation concept. For details on these flow management concepts see Appendix B or TM 5.2 in Volume 5. The next most critical trigger for the Priority B concept option relates to adopting potable reuse regulations.

The highest-ranked potable reuse opportunity, Concept Option #15 (the DCTWRP to the LAAFP), requires potable reuse with raw water augmentation regulation approval, while the second-highest concept option, Concept Option #16 (the DCTWRP to LADWP's Distribution System), requires potable reuse with treated water augmentation regulation approval. If the potable regulations are not in effect within the desired timeframe, or the City prefers a more conventional form of water reuse, the third-best potable reuse option from the DCTWRP is Concept Option #9 (Groundwater Augmentation from the DCTWRP to the San Fernando Basin Injection Wells).



The Donald C. Tillman WRP supplies the Japanese Gardens with advanced treated recycled water.

ES.7.4.3 LA-Glendale Water Reclamation Plant

As shown on Figure ES.4, the WWFP's CIP includes 25 projects with a combined estimated cost of \$227 million for the LAGWRP. Two concept options were also identified for the LAGWRP. These concept options, in order of priority, are as follows:

- **Priority A: Concept Option #17** – Potable reuse with treated water augmentation from LAGWRP to Headworks Reservoir.
- **Priority B: Concept Option #23** – Non-potable reuse from LAGWRP to increase NPR demand beyond 2015 UWMP.

The most critical trigger for implementing the Priority A Concept Option #17 (LAGWRP to Headworks Reservoir) is adopting potable reuse with treated water augmentation regulations that would allow this type of water reuse practice.

If the potable regulations are not approved within the desired timeframe, or the City prefers a more conventional form of water reuse, the Priority B Concept Option #23 (Increase NPR demand beyond 2015 UWMP) could be considered for the remaining available flows. The most critical trigger for this option is new customer demand that is cost-effective to serve, considering the customer's location, demand size, demand variability, and water quality requirements.



To increase water recycling at LAGWRP key modifications are in the planning stage such as providing additional equalization capacity.

ES.7.4.4 Terminal Island Water Reclamation Plant

As shown on Figure ES.4, the WWFP's CIP includes 32 projects with a combined estimated cost of \$303 million for the TIWRP. One concept option was initially identified and evaluated for the TIWRP as part of the plant's future integration opportunities, namely Concept Option #23. This option



The advanced treatment capacity at TIWRP was recently expanded to 12 mgd enabling TIWRP to recycle 100 percent of its wastewater with advanced water purification.

involves expanding the NPR from the TIWRP beyond the forecasts identified in the 2015 UWMP. However, the majority of the current plant flow is already reused and future tributary flow increases are limited.

Moreover, installing additional treatment facilities at the TIWRP is not recommended, because the plant was recently upgraded with a 12 million gallons per day (mgd) advanced treatment facility, and there could be conflicts with the conditional discharge requirements during low-demand. As a result, no concept options were recommended for TIWRP.

ES.7.5 Recommended Wastewater Projects

The WWFP's CIP combines capital improvement projects for the wastewater collection system and the four WRPs, as well as in-progress projects, current integration opportunities, future integration opportunities (concept options) pertaining to the wastewater system, and climate resiliency projects. To avoid including projects twice, the Executive Summary's CIP for wastewater projects is limited to the estimated cost of wastewater improvement projects associated with the four WRPs and the collection system.

The total estimated cost of wastewater improvement projects associated with the City's existing four WRPs and the collection system is \$3.4 billion. As shown on Figure ES.5, improvements associated with the Hyperion WRP account for nearly half (44 percent) of the WWFP's CIP, totaling \$1.5 billion. The improvements associated with Donald C. Tillman WRP and the collection system account for a similar share (40 percent), with \$1.4 billion. The remaining \$0.5 billion is associated with improvements at the LA-Glendale WRP and Terminal Island WRP. The WWFP's CIP also includes 37 projects resulting from the climate resiliency analysis with a combined estimated capital cost of \$56 million.

More details on the proposed WWFP's CIP are included in Chapter 7, while the complete WWFP CIP is provided in Appendix C.

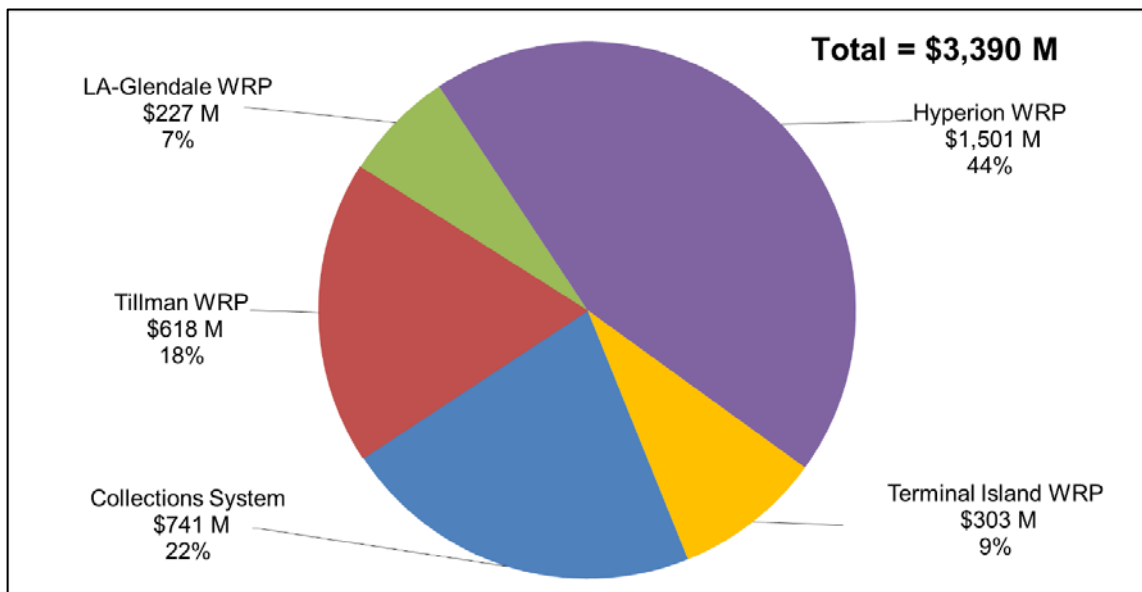

Figure ES.5 Estimated Cost Distribution of Wastewater Projects by WRP

ES.7.5.1 Wastewater Related Policy Recommendations

In addition to the existing wastewater projects and the recommended concept options, the One Water LA policies outline strategies for developing guidelines for on-site treatment facilities (OSTFs). Two of the recommended policies for these OSTFs include (1) developing guidelines that protect public health and outline operations of wastewater and recycled water systems (#38), and (2) providing a fee structure and payment guidelines that reflect collection and treatment system impacts and costs (#39). Stakeholders also recommended expanding education and engagement programs on Potable Reuse (#35).

The recommended wastewater related policies are summarized in Table ES.2. A full list of the policies and action items can be found in Chapter 9 and Appendix E.

ES.8 CURRENT INTEGRATION OPPORTUNITIES

The One Water LA team asked its steering committee members for a list of their top 3 to 5 current projects or planning efforts that provide opportunities for collaboration with other departments or agencies. The purpose is to identify opportunities to integrate water elements and improve the projects' efficiency, cost effectiveness, and sustainability.

The One Water LA team obtained this list to create practical examples of interdepartmental and interagency collaboration, identify agreements and policies needed to resolve complexities hindering project implementation, and to highlight One Water LA "quick success" stories that provide multiple benefits. A total of 44 water-related projects or planning efforts were received from 12 different departments/agencies of the steering committee. The approximate locations of these 44 current integration opportunities with a spatial location are depicted on Figure ES.6, along with the top 5 opportunities.



Note: Agency acronyms are provided in the acronyms list.

A total of 44 water-related current integration opportunities were identified by 12 different steering committee members.

The 44 current integration opportunities were narrowed down to 10 using a screening criteria process. To enable prioritization, additional information was gathered. The top five current integration opportunities were then further developed as case study examples for interdepartmental and interagency collaboration. Three of these five case studies have gained momentum and are already moving forward, namely: Advanced Treated Recycled Water Delivery to LAX and Scattergood Generating Station, Restoration of G2 Parcel at Taylor Yard, and Water Management Strategies for the LA Zoo's Master Plan,

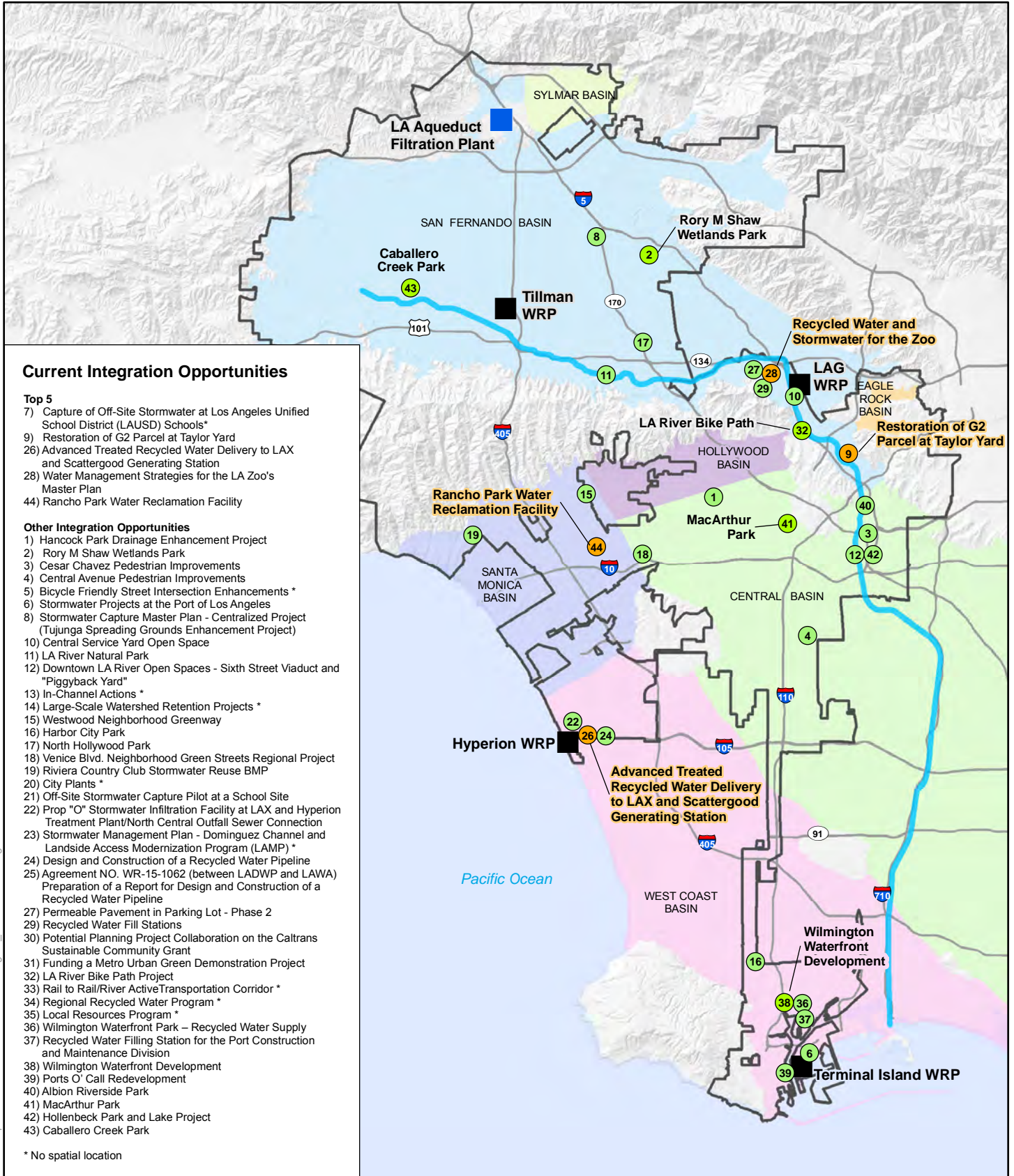

Current Integration Opportunities

- Top 5**
- 7) Capture of Off-Site Stormwater at Los Angeles Unified School District (LAUSD) Schools*
 - 9) Restoration of G2 Parcel at Taylor Yard
 - 26) Advanced Treated Recycled Water Delivery to LAX and Scattergood Generating Station
 - 28) Water Management Strategies for the LA Zoo's Master Plan
 - 44) Rancho Park Water Reclamation Facility
- Other Integration Opportunities**
- 1) Hancock Park Drainage Enhancement Project
 - 2) Rory M Shaw Wetlands Park
 - 3) Cesar Chavez Pedestrian Improvements
 - 4) Central Avenue Pedestrian Improvements
 - 5) Bicycle Friendly Street Intersection Enhancements *
 - 6) Stormwater Projects at the Port of Los Angeles
 - 8) Stormwater Capture Master Plan - Centralized Project (Tujunga Spreading Grounds Enhancement Project)
 - 10) Central Service Yard Open Space
 - 11) LA River Natural Park
 - 12) Downtown LA River Open Spaces - Sixth Street Viaduct and "Piggyback Yard"
 - 13) In-Channel Actions *
 - 14) Large-Scale Watershed Retention Projects *
 - 15) Westwood Neighborhood Greenway
 - 16) Harbor City Park
 - 17) North Hollywood Park
 - 18) Venice Blvd. Neighborhood Green Streets Regional Project
 - 19) Riviera Country Club Stormwater Reuse BMP
 - 20) City Plants *
 - 21) Off-Site Stormwater Capture Pilot at a School Site
 - 22) Prop "O" Stormwater Infiltration Facility at LAX and Hyperion Treatment Plant/North Central Outfall Sewer Connection
 - 23) Stormwater Management Plan - Dominguez Channel and Landside Access Modernization Program (LAMP) *
 - 24) Design and Construction of a Recycled Water Pipeline
 - 25) Agreement NO. WR-15-1062 (between LADWP and LAWA) Preparation of a Report for Design and Construction of a Recycled Water Pipeline
 - 27) Permeable Pavement in Parking Lot - Phase 2
 - 29) Recycled Water Fill Stations
 - 30) Potential Planning Project Collaboration on the Caltrans Sustainable Community Grant
 - 31) Funding a Metro Urban Green Demonstration Project
 - 32) LA River Bike Path Project
 - 33) Rail to Rail/River Active Transportation Corridor *
 - 34) Regional Recycled Water Program *
 - 35) Local Resources Program *
 - 36) Wilmington Waterfront Park - Recycled Water Supply
 - 37) Recycled Water Filling Station for the Port Construction and Maintenance Division
 - 38) Wilmington Waterfront Development
 - 39) Ports O' Call Redevelopment
 - 40) Albion Riverside Park
 - 41) MacArthur Park
 - 42) Hollenbeck Park and Lake Project
 - 43) Caballero Creek Park

* No spatial location

Legend

- Existing Water Reclamation Plant (WRP)
- Existing Water Filtration Plant
- City of Los Angeles
- Groundwater Basin
Source: LACDPW
- Current Integration Opportunity Project Location
Top 5
- Other Integration Opportunities

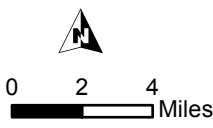

Hillshade Source: CalAtlas
<http://www.atlas.ca.gov>

Figure ES.6
Location of Current Integration Opportunities
One Water LA 2040 Plan
Summary Report

Document Path: \\io-fs-1\Data\GIS\ISBackup\LA ONE WATER\OWLA\MXD\Figs-1_CurrentTermIntegration.mxd



- **Advanced Treated Recycled Water Delivery to LAX and Scattergood Generating Station –**

Under this project, a new advanced water purification facility will be added at the HWRP to deliver advanced treated recycled water to the Los Angeles International Airport (LAX) and the Scattergood Power Plant Generating Station. The project involves collaboration between LASAN, LADWP, and Los Angeles World Airports (LAWA). The multiple benefits provided by this project are as follows:



- Offsets potable water demands by converting all landscape areas to recycled water irrigation, discontinuing irrigation in non-public areas, and converting turf to bark/stone.
- Provides opportunities for extensive educational outreach due to LAX's high passenger count.
- Uses product water from the Advanced Treatment Facility Pilot at HWRP.

- **Capture of Off-Site Stormwater at Los Angeles Unified School District (LAUSD) Schools –** This

pilot study involves capturing and treating off-site stormwater for recharge or reuse at a school site as a demonstration for other LAUSD school sites. This concept option augments stormwater use at school sites, since the LAUSD is already responsible for capturing its on-site stormwater.



The LAUSD would lead the project, while the LASAN, LADWP, and Division of State Architect (DSA) would be supporting agencies. The

project would provide the following benefits:

- Removes trash and solids from stormwater diverted from a local storm drain.
- Conveys diverted stormwater onto the selected school site and uses it for either infiltration or irrigation.
- Focuses on areas where regional stormwater facilities could optimize infiltration and on-site use while meeting multiple objectives and benefits.

- **Rancho Park Water Reclamation Facility –** Under this

project, one or multiple satellite water reclamation facilities would be added to produce recycled water. The recycled water would be augmented with dry weather runoff and stormwater, when available, to serve non-potable water demands near Rancho Park (West LA).



LASAN would lead the project, while LADWP and Los Angeles Department of Recreation and Parks (RAP) would be supporting agencies. This project provides the following benefits:

- Produces recycled water to meet substantial non-potable demands in the Westside area, including industrial uses and irrigation for the UCLA campus, the City's largest municipal golf course, and several other users.

- Captures stormwater to retain, treat, and remove pollutants such as trash, metals, and bacteria.
- Increases climate resiliency and reliability of water supply by being locally sourced.

- **Restoration of G2 Parcel at Taylor Yard** – This project involves developing an approximately 41-acre former rail yard site consisting of stormwater BMPs, potentially using recycled water, and completing site remediation.



The LA River Works office (part of the Los Angeles Bureau of Engineering [BOE]) is the project lead, while LADWP, LASAN, and RAP are the supporting agencies. This project provides the following benefits:

- Implements stormwater BMPs.
- Meets substantial non-potable demands.
- Remediates a large former rail yard site for beneficial uses.

•**Water Management Strategies for the LA Zoo's Master Plan** –

This project includes considering stormwater and recycled water in the LA Zoo Master Plan to promote using stormwater BMPs and recycled water for animal exhibits, washdown, and irrigation at the LA Zoo.

The LA Zoo would lead the project, while LADWP, LASAN, and RAP would be supporting agencies. This project provides the following benefits:

- Decreases the LA Zoo's potable water use.
- Identifies information gaps, water quality requirements for using recycled water in animal exhibits, funding opportunities, and other steps necessary to evaluate recycled water and stormwater capture uses.
- Applies information collected from this effort to other zoos and animal shelters in the region and country.



ES.8.1 Recommended Current Integration Opportunities

In addition to the 44 current integration opportunities, other projects emerged while the Plan was developed, some of which stakeholders provided. The One Water LA team recommends conducting a periodic review and update of the "living" list of integration opportunities to solicit new ideas and identify any missing projects. During these updates, it would also be important to reexamine the current list and further explore or accelerate the most beneficial projects.

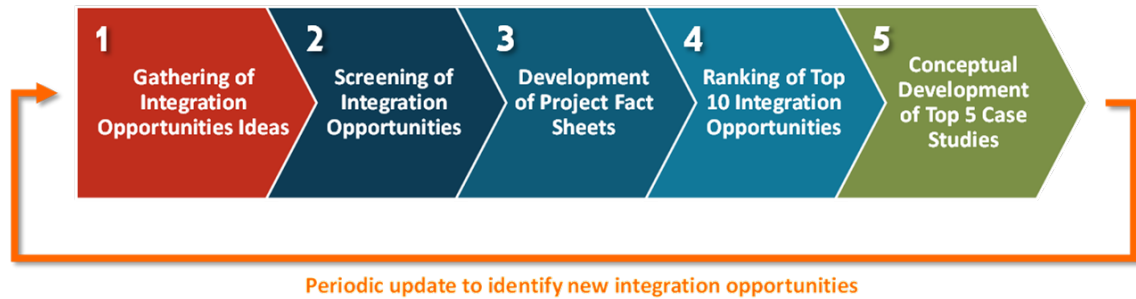

The current integration opportunities case studies were developed in a five step process and it is recommended to periodically assess new integration opportunities.

Since most of these projects are still in the early planning stages, it was assumed that some of the 44 current integration opportunities would not be implemented due to new conditions, cost-effectiveness, or other implementation concerns. As a result, it was assumed that approximately 80 percent of the opportunities would actually be implemented within the planning horizon of 2040. The total estimated cost associated to implement approximately 80 percent or 35 of the 44 near-term integration opportunities is \$1.8 billion. Detailed discussions of the current integration opportunities are included in Chapter 5.

ES.9 FUTURE INTEGRATION OPPORTUNITIES

Future integration opportunities were developed to identify long-term strategies that help achieve the Sustainable City pLAN goals relating to water quality and water supply, and that are also in alignment with the One Water LA Objectives and Guiding Principles.

ES.9.1 Water Management Strategies

Through a series of workshops, stakeholder meetings, and engagement with the One Water LA team, various existing and future water management strategies were identified. For each strategy, one or more new projects (concept options) were identified and developed to a conceptual level. After evaluating 27 concept options and receiving input from stakeholders, recommended future integration opportunities

and associated water management strategies were identified. The recommended concept options include eight different water management strategies, as shown on the graphic to the right. The only strategy that is not included in the Plan recommendations is ocean desalination. Ocean desalination was eliminated because stakeholder surveys indicated desalination as the least favored option and the City has many more attractive potable reuse alternatives and stormwater strategies available that collectively can provide sufficient local supplies while avoiding environmental concerns, such as harm to marine life and the high carbon footprint associated with ocean desalination.



The Plan recommendations include a variety of project concepts that represent eight different water management strategies.

The prioritized list of future integration opportunities was developed to help the City decide which water management strategies and concept options are most viable for further study and could be implemented by 2040 or beyond. Currently, all concepts are still being evaluated and the City has not yet committed to implementation of any of the concept options described.

ES.9.1.1 Concept Options

The Plan's 27 concept options are a mix of projects and programs that maximize recycled water use, enhance stormwater capture, contribute to supply sustainability, and provide multiple water quality benefits. A map of each concept and its respective conceptual water routing location is shown on Figure ES.7. A detailed description of the concept development, evaluation, and prioritization process is included in Chapter 6.

ES.9.1.2 Portfolio Evaluation

The concept options from Figure ES.7 were grouped into themed portfolios based on a possible extreme future scenario ("theme"). For example, if in the future the City decides to only implement projects that maximize environmental benefits, then the concept options that maximize environmental benefits would be prioritized first. The four themes assessed were: 1) minimizing cost, 2) maximizing environmental benefits, 3) maximizing institutional collaboration, and 4) maximizing local water supplies. A scenario planning analysis was conducted to develop a list of the most beneficial concept options under each of the four different themes. The most beneficial concept options from each themed portfolio were then combined into a preferred portfolio.

Although several concept options are not included in the preferred portfolio, some concepts remain strong, viable alternatives if certain decisions anticipated in the future ("triggers") do not materialize. Detailed discussions of the concept options and implementation triggers, are included in Chapters 6 and 9, respectively.

Document Path: E:\JACKIEBKU\UO\WLA\MXD\ConceptOptions_TM52.mxd

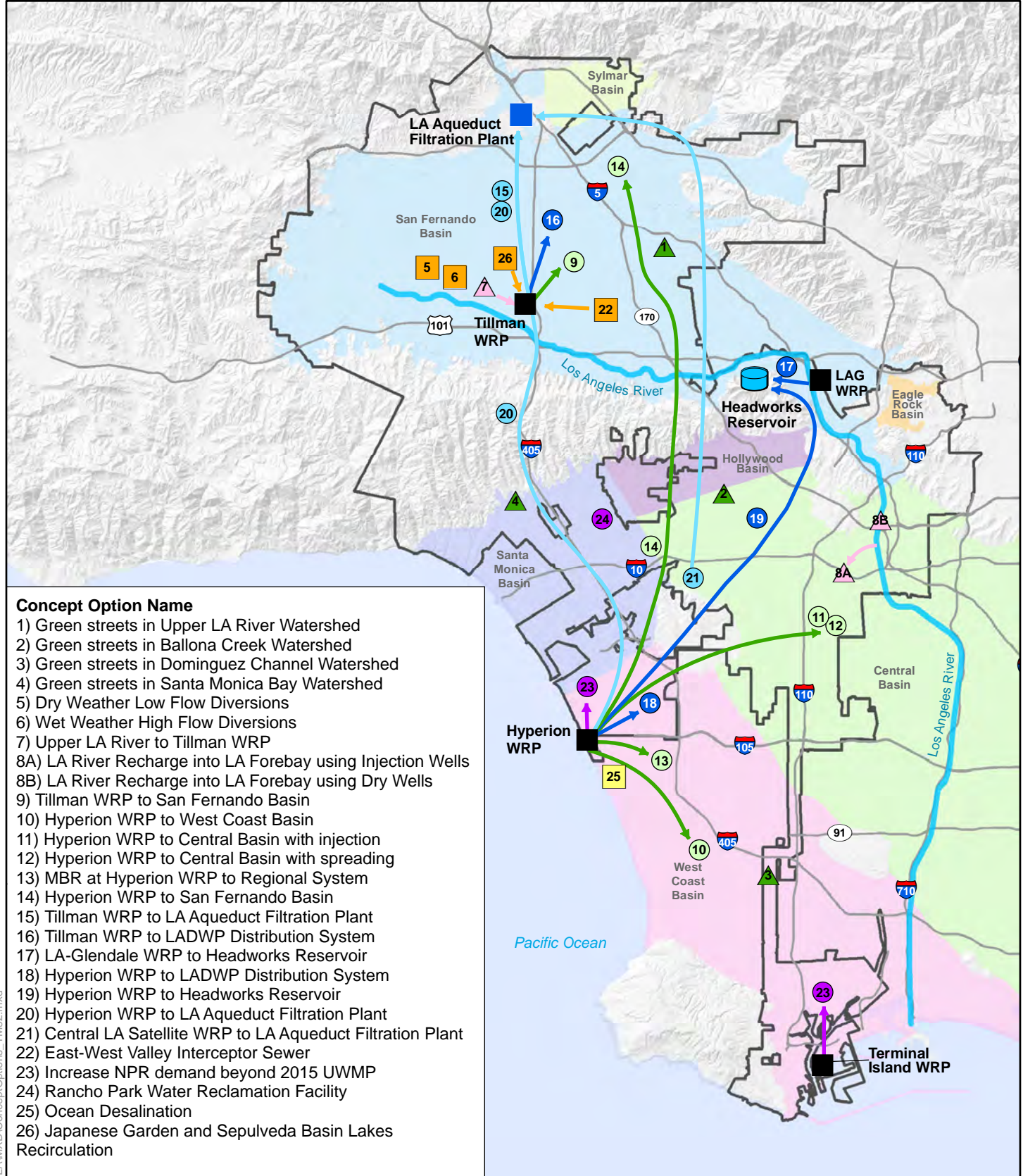

Concept Option Name

- 1) Green streets in Upper LA River Watershed
- 2) Green streets in Ballona Creek Watershed
- 3) Green streets in Dominguez Channel Watershed
- 4) Green streets in Santa Monica Bay Watershed
- 5) Dry Weather Low Flow Diversions
- 6) Wet Weather High Flow Diversions
- 7) Upper LA River to Tillman WRP
- 8A) LA River Recharge into LA Forebay using Injection Wells
- 8B) LA River Recharge into LA Forebay using Dry Wells
- 9) Tillman WRP to San Fernando Basin
- 10) Hyperion WRP to West Coast Basin
- 11) Hyperion WRP to Central Basin with injection
- 12) Hyperion WRP to Central Basin with spreading
- 13) MBR at Hyperion WRP to Regional System
- 14) Hyperion WRP to San Fernando Basin
- 15) Tillman WRP to LA Aqueduct Filtration Plant
- 16) Tillman WRP to LADWP Distribution System
- 17) LA-Glendale WRP to Headworks Reservoir
- 18) Hyperion WRP to LADWP Distribution System
- 19) Hyperion WRP to Headworks Reservoir
- 20) Hyperion WRP to LA Aqueduct Filtration Plant
- 21) Central LA Satellite WRP to LA Aqueduct Filtration Plant
- 22) East-West Valley Interceptor Sewer
- 23) Increase NPR demand beyond 2015 UWMP
- 24) Rancho Park Water Reclamation Facility
- 25) Ocean Desalination
- 26) Japanese Garden and Sepulveda Basin Lakes Recirculation

Legend

Existing Water Reclamation Plant (WRP)	City of Los Angeles	LA River Storage and Use
Existing Reservoir	Strategy Category	Flow Management
Existing Water Filtration Plant	Non-Potable Reuse	Already Proposed Stormwater Management Projects
Groundwater Basin Source: LACDPW	Potable Reuse with Groundwater Augmentation	Ocean Desal Plant
	Potable Reuse with Raw Water Augmentation	
	Potable Reuse with Treated Water Augmentation	

Hillshade Source: CalAtlas
<http://www.atlas.ca.gov>

Figure ES.7
Concept Options
Overview Map
One Water LA 2040 Plan
Summary Report

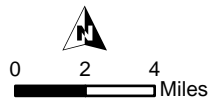

ES.9.1.3 Preferred Portfolio

The preferred portfolio is the recommended group of concept options. By implementing these concept options, the preferred portfolio supports the stormwater and receiving water quality as well as major water-related Sustainable City pLAN goals.

The preferred portfolio also includes existing supply sources, projects that are already in progress (as of November 2016), stormwater management projects that had already been proposed, and six new concept options. These new concept options and the estimated new local water supply yield, estimated capital cost, and yield-weighted unit cost expressed in dollars per acre-foot (\$/AF) are summarized in Table ES.1.

Table ES.1 New Concept Options of Preferred Portfolio Summary Report One Water LA 2040 Plan					
#	Concept Option Name	Estimated New Yield (AFY)	Estimated New Yield (mgd)	Estimated Capital Cost (\$M)	Yield- Weighted Unit Cost (\$/AF)
New Concept Options					
5	Dry Weather Low Flow Diversions	6,200	5.5	\$110	\$1,000
8A	LA River Recharge into LA Forebay using Injection Wells	25,000	22	\$980	\$2,100
13	Potable Reuse Groundwater Augmentation - MBR at HWRP to Regional System ⁽¹⁾	95,000 ⁽²⁾	85	\$900	\$1,500
15	Potable Reuse Raw Water Augmentation - DCTWRP to LA Aqueduct Filtration Plant ⁽²⁾	15,000	14	\$310	\$1,500
17	Potable Reuse Treated Water Augmentation - LAGWRP to Headworks Reservoir ⁽¹⁾	6,000 ⁽²⁾	3.2	\$140	\$1,500
22	East West Valley Interceptor Sewer	n/a ⁽³⁾	11.4 ⁽³⁾	\$85	\$430
Totals of New Concept Options Only⁽⁴⁾		147,200	136	\$2,525	\$1,600
Notes:					
(1) The estimated yield of Concept Options #13 and #17 could not be fully utilized during normal and wet year conditions with the supply mix assumptions obtained from the 2015 UWMP.					
(2) Requires the East-West Valley Interceptor Sewer (Concept Option #22) or other flow management option to increase flows to DCTWRP.					
(3) Estimated capacity of EWVIS is 11.4 mgd and does not provide a new supply, but only a flow increase to DCTWRP due to rerouting.					
(4) Excludes new yield and cost estimates associated with Benchmark Portfolio projects and programs.					

As shown in Table ES.1, the new concept options in the preferred portfolio have an estimated combined yield of 147,200 AFY, excluding the capacity of Concept Option #22 (East-West Valley Interceptor Sewer), since it is merely a flow management concept that does not generate new supply on its own. The Japanese Garden and Sepulveda Basin Lakes Recirculation concept (Concept Option #26) could be an alternative or addition to the EWWIS, see Appendix B for details on Concept Option #26.

The following sections briefly summarize the recommended concept options included in the preferred portfolio. Schematics of all 27 concept options are included in Appendix B. Individual concept description sheets are included in Appendix C of TM 5.2 in Volume 5.

Concept Option 5: Dry Weather Low Flow Diversions

This concept option proposes collecting low flows from the stormwater system and transferring them to the sewer system for treatment. Under normal year conditions, the estimated yield from city-wide implementation is 6,200 AFY, while the yield-weighted unit cost is roughly \$1,000 per AF. The concept flow schematic is shown on Figure ES.8.

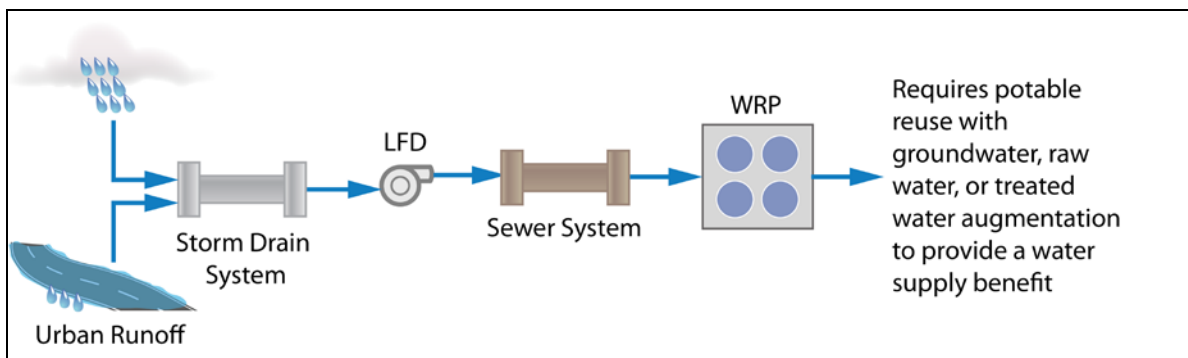

Figure ES.8 Dry Weather Low Flow Diversions

The key benefits associated with this concept option include, but are not limited to:

- Minimizes or eliminates the discharge of potentially polluted dry-weather flow runoff from receiving waters.
- Diverts dry-weather runoff in the stormwater collection system to the sewer collection to be conveyed to a water reclamation plant for treatment and reuse.

Moreover, this concept option helps fulfill the following One Water LA objectives and guiding principles:

- Improve health of local watersheds.
- Improve local water supply reliability.
- Integrate management of water resources and policies.
- Balance environmental, economic, and societal goals.

Concept Option 8A: LA River Recharge into LA Forebay using Injection Wells

This concept option proposes diverting flows from the LA River to the LA Forebay to recharge Central Basin. Under normal year conditions, the estimated yield is 25,000 AFY, while the yield-weighted unit cost is roughly \$2,100 per AF. The concept flow schematic is shown on Figure ES.9. For additional details regarding the LA River refer to the LA River Flow Study, Volume 4 of the Plan.

The key benefits associated with this concept option include, but are not limited to:

- Extracts and reuses water that would otherwise be lost to the ocean.
- Replenishes the Central Basin groundwater aquifer.

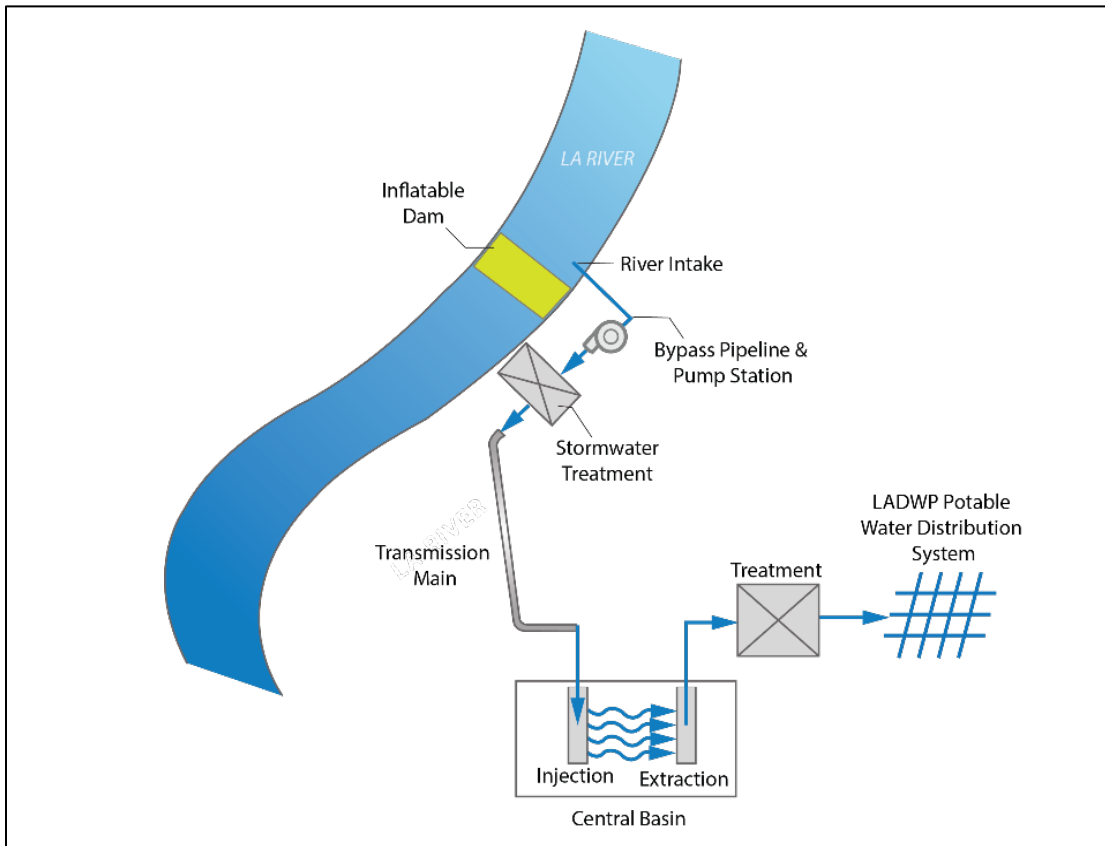

Figure ES.9 LA River Recharge into LA Forebay using Injection Wells

Moreover, this concept option helps fulfill the following One Water LA objectives and guiding principles:

- Improve local water supply reliability.
- Increase climate resilience.
- Increase community awareness and advocacy for sustainable water.

Concept Option 13: Potable Reuse - MBR at Hyperion WRP to Regional System

This concept proposes treating HWRP effluent with a membrane bioreactor (MBR) and delivers water to a regional system for recharge into a groundwater basin, which will be extracted for potable use by other regional systems. This project may also be used in the future for potable reuse with raw water augmentation. Advanced treatment by the regional system will be required. The LADWP could purchase this water from a regional system for potable use.

Under normal year conditions, the estimated yield is 95,000 AFY, while the yield-weighted unit cost is roughly \$1,500 per AF. The concept flow schematic is shown on Figure ES.10.

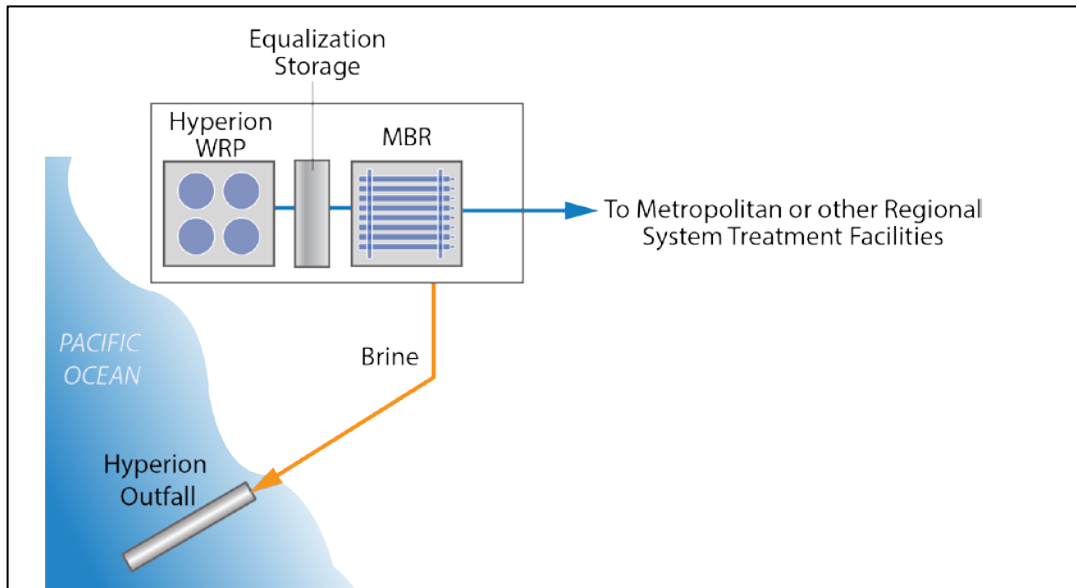

Figure ES.10 Potable Reuse - MBR at Hyperion WRP to Regional System

The key benefits associated with this concept option include, but are not limited to:

- Uses 100 percent of Hyperion Water Reclamation Plant flows for recycling eliminating discharge to the ocean.
- Promotes collaboration with regional partners.
- Delivers water to a regional system for recharge into a groundwater basin, which will be extracted for potable reuse and sold to water retailers at full service rates.

Moreover, this concept option helps fulfill the following One Water LA objectives and guiding principles:

- Implement, monitor, and maintain a reliable wastewater system.
- Improve local water supply reliability.
- Integrate management of water resources & policies.
- Increase climate resilience.

Concept Option 15: Potable Reuse Raw Water Augmentation - Donald C. Tillman WRP to Los Angeles Aqueduct Filtration Plant

This concept option proposes expanding the DCTWRP Advanced Water Purification Facility (AWPF) and conveys potable reuse flows with raw water augmentation to the Los Angeles Aqueduct Filtration Plant (LAAFP), and then to LADWPs system for distribution.

Under normal year conditions, the estimated yield is 15,000 AFY, while the yield-weighted unit cost is roughly \$1,500 per AF. The concept flow schematic is shown on Figure ES.11.

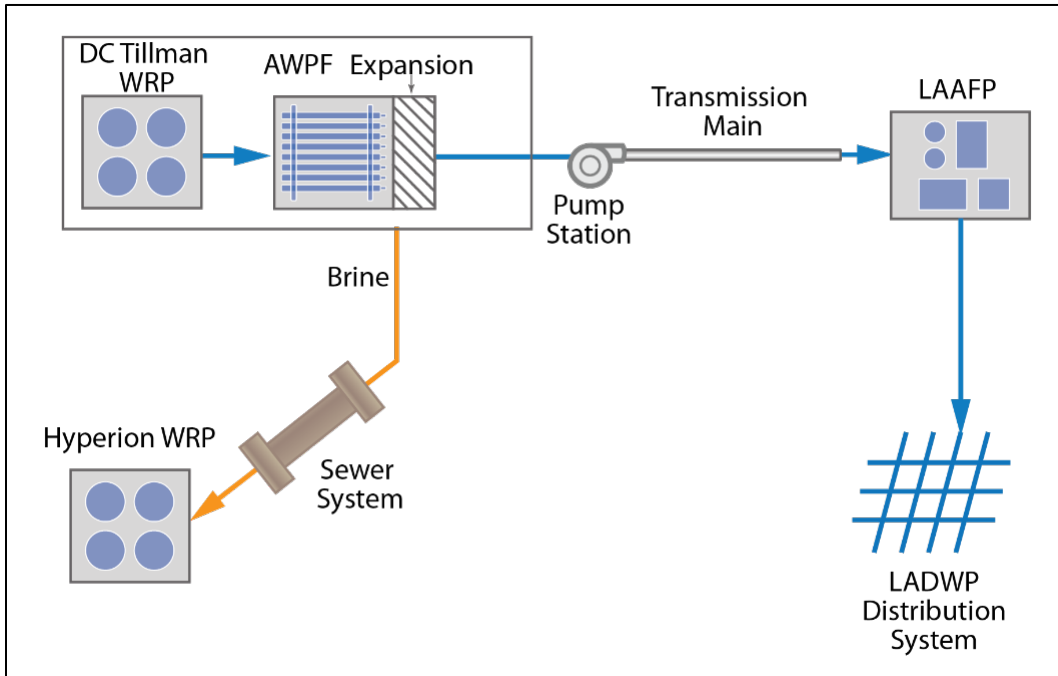

Figure ES.11 Potable Reuse Raw Water Augmentation - Tillman WRP to Los Angeles Aqueduct Filtration Plant

The key benefits associated with this concept option include, but are not limited to:

- Expands use of potable reuse with raw water augmentation.
- Increases DCTWRP's flows for recycling.

Moreover, this concept option helps fulfill the following One Water LA objectives and guiding principles:

- Implement, monitor, and maintain a reliable wastewater system.
- Improve local water supply reliability.
- Integrate management of water resources and policies.
- Increase climate resilience.

Concept Option 17: Potable Reuse Treated Water Augmentation - LA-Glendale WRP to Headworks Reservoir

This concept option proposes treating LAGWRP effluent at an Advanced Water Purification Facility (AWPF) and pumps water directly into the LADWP distribution system at the Headworks Reservoir. Instead of siting the AWPF at LAGWRP, an AWPF could be sited at the Headworks Reservoir, however, this siting location was not part of this evaluation and further studies are required.

Under normal year conditions, the estimated yield is 3,600 AFY, while the yield-weighted unit cost is roughly \$1,500 per AF. The concept flow schematic is shown on Figure ES.12.

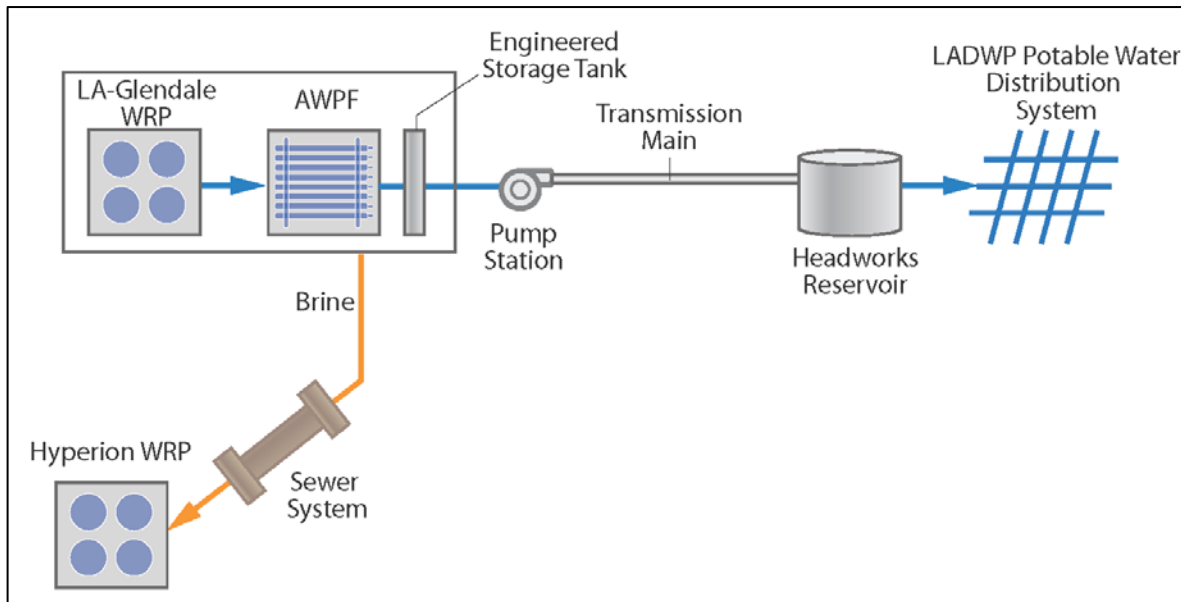

Figure ES.12 Potable Reuse Treated Water Augmentation - LA-Glendale WRP to Headworks Reservoir

The key benefits associated with this concept option include, but are not limited to:

- Expands LAGWRP's treatment technology and increases flows available for recycling.
- Expands use of potable reuse with treated water augmentation.

Moreover, this concept option helps fulfill the following One Water LA objectives and guiding principles:

- Implement, monitor, and maintain a reliable wastewater system.
- Improve local water supply reliability.
- Integrate management of water resources and policies.
- Increase climate resilience.

Concept Option 22: East West Valley Interceptor Sewer

This concept option proposes implementation of the East West Valley Interceptor Sewer (EWWIS) project, which would convey additional wastewater flows from the eastern part of the San Fernando Valley to DCTWRP.

The EWWIS has an estimated capacity of 11.4 mgd and does not provide a new supply. Instead, it merely increases flow to DCTWRP due to rerouting. The yield-weighted unit cost is roughly \$430 per AF. The concept flow schematic is shown on Figure ES.13.

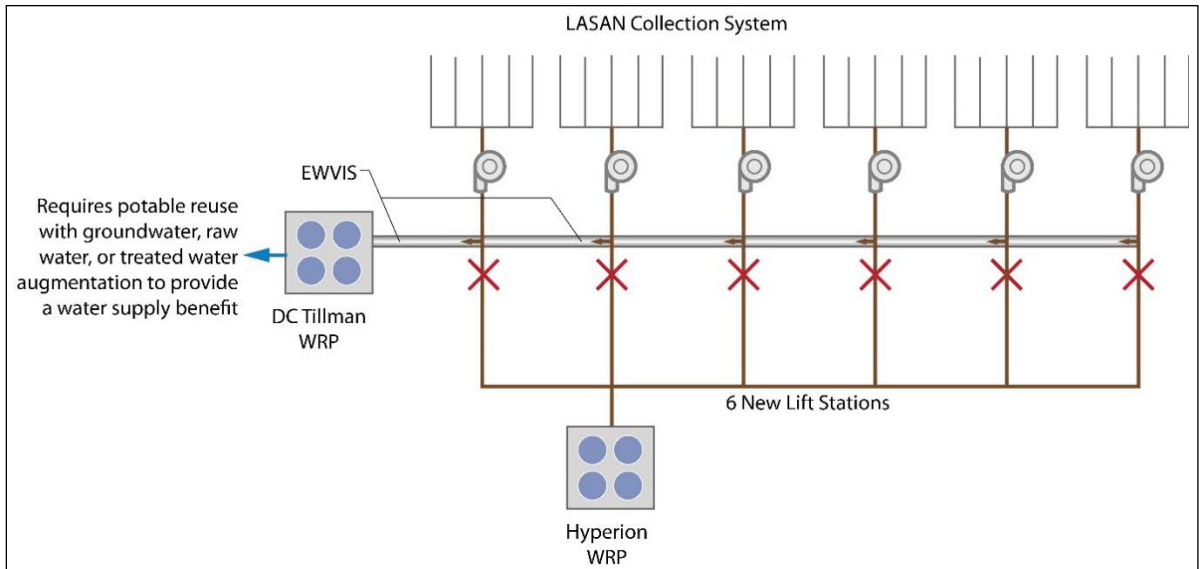

Figure ES.13 East-West Valley Interceptor Sewer

The key benefit associated with the implementation of the EWWIS includes, but is not limited to:

- Maximizing the City water reclamation plants' available production and reuse capacity (i.e. direct water where it is needed) by redirecting wastewater from one sewershed to another.

Moreover, this concept option helps fulfill the following One Water LA objectives and guiding principles:

- Implement, monitor, and maintain a reliable wastewater system.
- Improve local water supply reliability.

ES.9.2 Recommended Future Integration Opportunities

As shown in Table ES.1 and on Figure ES.14, the corresponding estimated cost of the new concept options in the preferred portfolio is approximately \$2.5 billion. Their yield-weighted average unit cost is approximately \$1,600 per acre-foot, assuming that all projects can be fully used continuously.

As shown on Figure ES.14, most of the costs are associated with Concept Option #8A (\$1 billion, or 39 percent) and Concept Option #13 (\$900 million, or 36 percent). The remaining five concept options represent a total cost of \$1 billion, or 35 percent of the total cost. As shown, the cost contribution of these six concepts ranges from 3 percent to nearly 39 percent of the total costs.

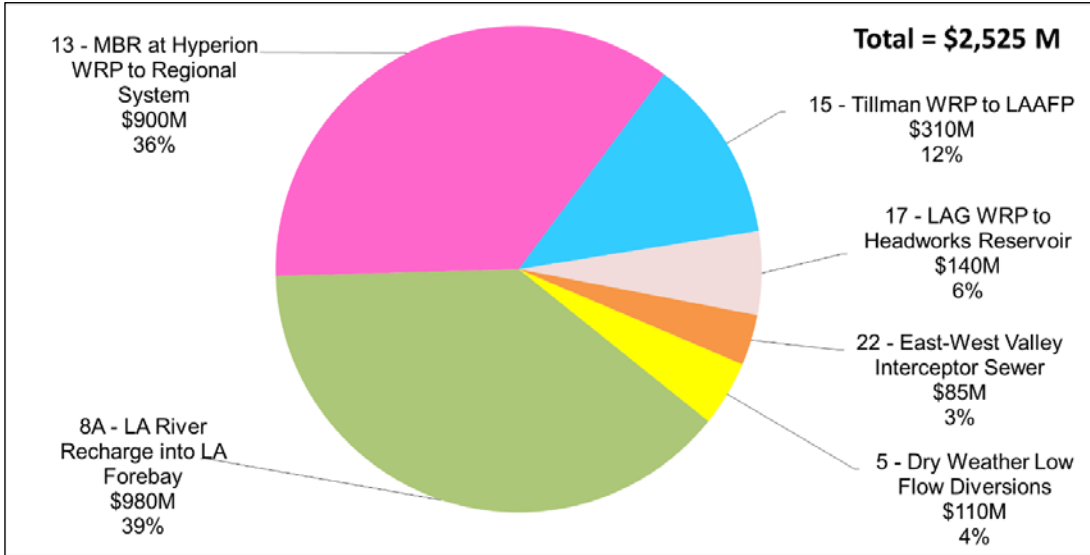

Figure ES.14 Estimated Cost Distribution of Future Integration Opportunities

ES.9.2.1 Trigger-based Implementation Strategy

The future integration opportunities cost phasing described above is based on the concept options in the preferred portfolio. However, as future conditions change, other concept options may become more attractive. To give the City a Plan that adapts to changing conditions, a trigger-based implementation strategy was developed. A trigger-based implementation strategy helps the City decide the best alternate concept options for its needs at a specific time in the future. If certain triggers do not materialize, other concept options could be alternatives to achieve the same overall goals.

As shown on Figure ES.15, the concept options in the preferred portfolio are referred to as Priority A, while alternative concepts are referred to as Priority B and Priority C. The dark blue rectangles indicate concept options providing potable and non-potable reuse solutions, while the light blue rectangles indicate concept options providing flow management solutions. The orange diamonds indicate decision points, called triggers. Each trigger may or may not occur, which is reflected in the "yes" or "no" answers to the question in the orange triangles.

For example, the first trigger question under LA River Storage and Use is "[Is there an] Institutional Agreement with [the] Water Replenishment District (WRD)?" If an agreement is established, one would follow the arrow labeled "yes" to the next trigger. If the City and WRD did not establish an institutional agreement, the arrow labeled "no" would be followed to the end of the flow chart labeled "no change."

City staff can continuously reevaluate all concept option priorities at each decision point (trigger) to account for any future changes in circumstances. In addition, neither project feasibility analyses nor phasing and implementation evaluations have been completed for the concepts. The trigger-based implementation strategy is discussed in detail in Chapter 9.

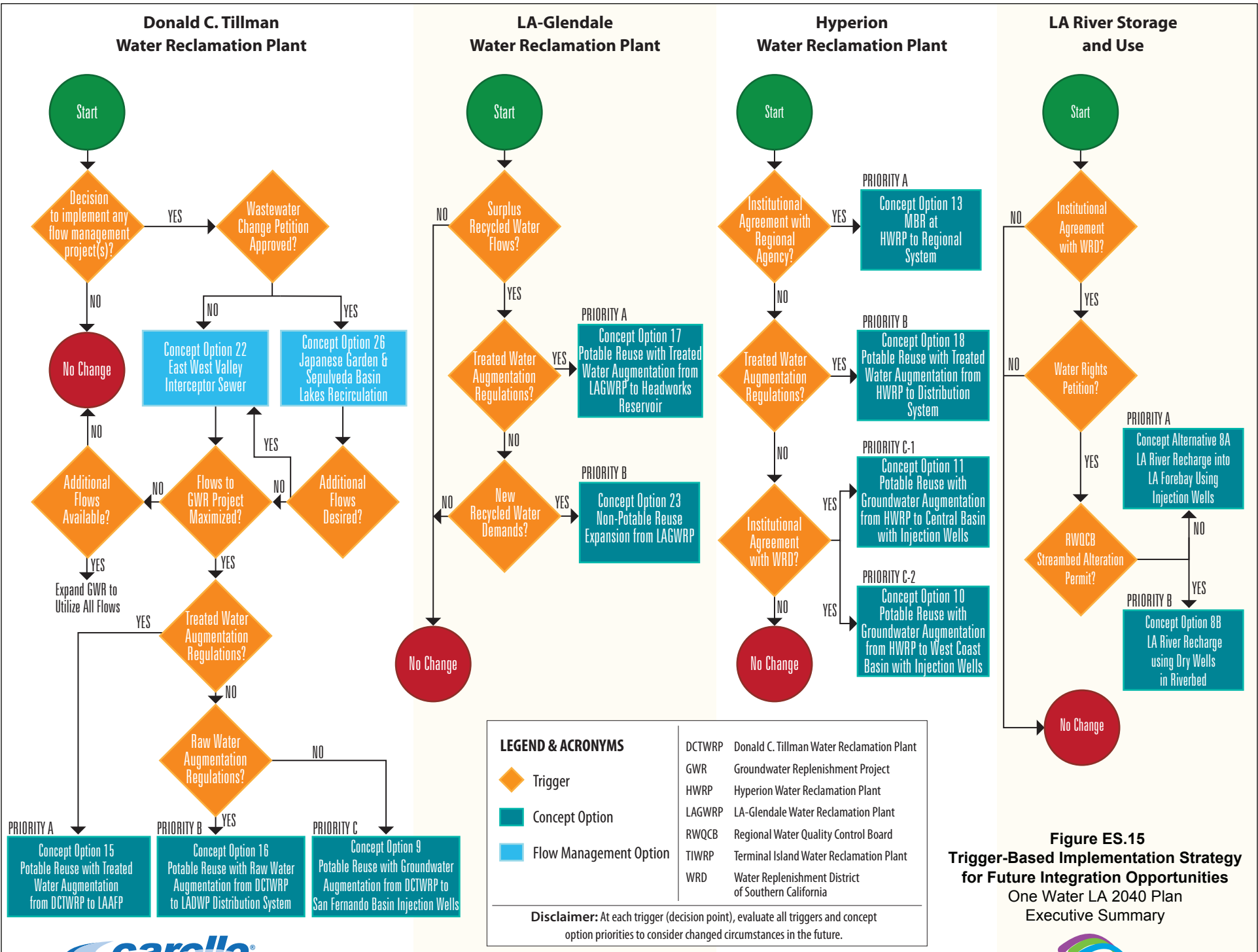

Figure ES.15
Trigger-Based Implementation Strategy
for Future Integration Opportunities
 One Water LA 2040 Plan
 Executive Summary



ES.10 POLICIES AND PROGRAMS

The Plan's policies and programs development approach builds on the experience gained and lessons learned during the Water IRP planning effort and One Water LA Phase 1. During One Water LA Phase 1, the steering committee requested "quick-fix" policies to facilitate better communication between departments and agencies and advance One Water LA Objectives and Guiding Principles more effectively. These policies and programs align with One Water LA's vision and are provided in Appendix E.

Under One Water LA Phase 2, the policy and program development process was expanded to include ideas and suggestions from both the steering committee and stakeholders. In total, over 200 policy and program ideas were collected that covered a variety of topics, such as:

- Integrated Planning and Design.
- Stormwater and Urban Runoff Management.
- Training and Education.
- Streamlining Collaboration and Implementation.
- Funding and Partnerships.
- Sustainability and Climate Change.
- Water Conservation.
- Recycled Water.
- LA River Revitalization.

An overview of the policy and program development process is shown on Figure ES.16. The last two steps, Feasibility Analysis and Phasing and Implementation, have not been completed and are ongoing efforts by the City. Chapter 9 includes a detailed explanation of the policy and program solicitation, development, consolidation, and prioritization process.

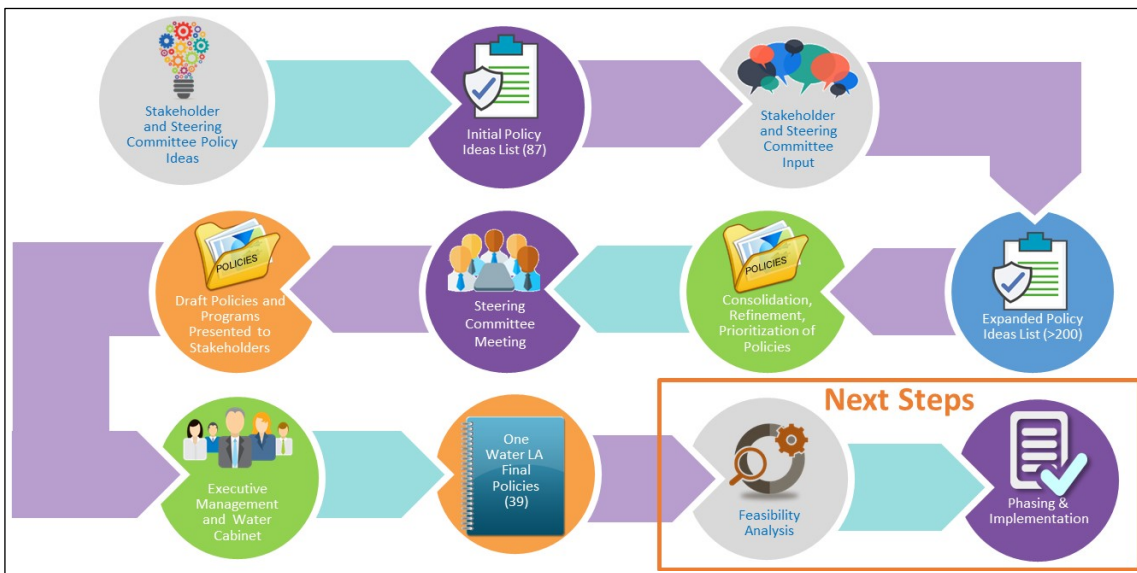

Figure ES.16 One Water LA Policy and Program Development Process

Table ES.2 summarizes the policy or program number, concept language, and lead and support agencies for the 39 recommended policies or programs. Each policy or program has several considerations that provide more context for implementation strategies. A more detailed table, which also includes the considerations, is included in Appendix F. Appendix F also identifies the policy and program prioritization category, the source(s) of the recommendation, if it meets multiple One Water LA Objectives, and if it was recommended to the Water Cabinet.

Policies and programs recommended by multiple sources and meeting multiple objectives were considered a higher priority in the initial prioritization process as they can have the greatest impact on achieving One Water LA Objectives and Guiding Principles and supporting the Sustainable City pLAn Goals.

To help advance policies and programs focused on integration, the One Water LA team presented the top 10 list of integration-related policy and program ideas to Mayor Garcetti's Water Cabinet. The Water Cabinet selected the following three policy and program ideas to champion for further advancement with the associated City departments:

- **Policy #12** – Maximize opportunities to incorporate integrated water management strategies, including green infrastructure, into ongoing and emerging opportunities.
- **Policy #11** – Create a citywide database to identify collaborative opportunities for water-related multi-benefit projects.
- **Policy #8** – Maximize the use of city-owned property for stormwater capture retrofits.

All 39 prioritized policies and programs are intended to remove barriers and increase efficiency. However, continued collaboration with numerous City departments, regional agencies, stakeholders, and elected officials within the City is needed to further refine the policies and conduct thorough feasibility assessments. Implementing the majority of recommended policies and programs will result in cost impacts including rebates, progress monitoring, and administrative support. Future studies on these costs and the anticipated benefits will need to be conducted to help prioritize the policy and program ideas with the greatest benefits. Due to current lack of available cost information, the Plan does not include any cost estimates related to implementing policies and programs. Recognizing that policies and programs are a key component to a One Water approach, the recommended next steps for identifying costs and advancing the policies are described in Chapter 9.

Table ES.2 Summary of Prioritized Policies and Programs Summary Report One Water LA 2040 Plan			
Number	Policy and Program Concept Language	Lead Agencies	Support Agencies
1	Update efficiency requirements in City's retrofit on resale program.	LADBS	LASAN, LADWP
2	Research best method and establish tracking system for graywater installations throughout the city. Consider potential impacts of graywater systems on water supply needs.	LASAN	LADWP, LADBS
3	Develop graywater user education information and signage for areas irrigated with graywater.	LADBS, LASAN, LADWP	County Health
4	Develop best method to encourage drainage water from swimming pools to be discharged into the sewer system rather than a street or storm drain.	LASAN	GSD, RAP, LADWP, and others
5	Develop robust stormwater pollution source control education measures that increase awareness and public participation.	LASAN	Public Works
6	Simplify the process and remove barriers to installing parkway swales and other distributed green infrastructure BMPs in the public right-of-way.	BOE	LASAN, LAFD, BSS, DCP, LADOT
7	Simplify the process and remove barriers to installing distributed green infrastructure BMPs on private properties in the City.	LADBS	LASAN, BOE, DCP, Regional Agencies
8	Maximize use of City-owned property for stormwater capture retrofits.	All City Depts.	LADWP, LASAN
9	Develop templates for standardized maintenance agreements and provide training to ensure maintenance of collaborative stormwater projects in the City.	LASAN	All City Depts., Regional Agencies
10	Maximize water supply opportunities in water quality compliance and improvement projects and programs.	LASAN	All City Depts.
11	Create a city-wide database to identify collaborative opportunities for water-related multi-benefit projects.	LADWP, BOE, LASAN	All City Depts., Regional Agencies
12	Maximize opportunities to incorporate integrated water management strategies, including green infrastructure, into ongoing and emerging opportunities.	LASAN	All City Depts., LACFCD, Other Regional Entities
13	Investigate the development of a stormwater capture retrofit ordinance that would require installing stormwater capture projects in homes upon resale.	LASAN	TBD
14	Update the Street Tree Selection Guide to better address climate change and water concerns.	BSS	LASAN, DCP

Table ES.2 Summary of Prioritized Policies and Programs Summary Report One Water LA 2040 Plan			
Number	Policy and Program Concept Language	Lead Agencies	Support Agencies
15	Identify a sufficient water supply for establishing and maintaining green infrastructure.	LADWP, LASAN	Water Cabinet
16	Create a vehicle that allows for shared operation and maintenance duties between multiple public agencies or public/private entities for stormwater BMPs.	LASAN, LADWP	Water Cabinet, All City Depts.
17	Create a process to expedite approval of public projects that help meet the Sustainable City pLAn, Watershed Management Programs, and One Water LA's objectives.	LASAN, LADWP, LADBS, LADOT, BOE	Water Cabinet
18	Streamline the process and coordinate the timing of approvals for builders implementing LID and Green Building requirements.	DCP	LASAN, DCP, LADBS
19	Identify the process or entity that will coordinate and manage all street and alley improvement efforts in the City.	DCP, BSS, BOE	DOT, LADWP, LASAN
20	Create a vehicle for continued department and regional agency collaboration beyond One Water LA 2040 Plan Development.	LASAN	Water Cabinet, All City Depts.
21	Develop a protocol for when and how private property owners will maintain the City's right-of-way stormwater improvements.	LASAN	BOE, BSS, LADWP
22	Evaluate and implement the most effective methods to incentivize stormwater capture retrofits.	LASAN	LADWP
23	Develop incentive programs to encourage reducing paved areas and increasing permeable pavements.	LASAN	BOE, LADWP
24	Create a "Percent for Green" fund that supports constructing Green Street facilities, and dedicate a minimum percent for green infrastructure.	LASAN	All City Depts.
25	Evaluate the feasibility of a program that allows properties to generate Stormwater Retention Credits (SRCs) for voluntary implementation of green infrastructure that reduces stormwater runoff.	LASAN	LADWP
26	Develop property owner recognition programs to promote and acknowledge stormwater capture retrofits and other sustainable practices.	LASAN	LADWP
27	Create a program to evaluate and facilitate public-private partnerships for water projects.	LADWP, LASAN	All City Depts.

Table ES.2 Summary of Prioritized Policies and Programs Summary Report One Water LA 2040 Plan			
Number	Policy and Program Concept Language	Lead Agencies	Support Agencies
28	Create a program to facilitate partnerships between City departments, regional agencies, and Non-Profit Organizations for water-related projects and programs.	LASAN, LADWP	All City Depts.
29	Develop tools and best methods to facilitate agency cost-sharing for multi-benefit projects and programs.	LASAN	All City Depts.
30	Explore the potential for establishing an Enhanced Infrastructure Financing District or other appropriate funding mechanism to fund capital projects and sustainable operations and maintenance.	LASAN	Mayor's Office (LA RiverWorks, City Services, and Economic Development)
31	Expand partnerships between the City and academia to advance water-related research and innovation.	LADWP, LASAN	Academia
32	Integrate climate adaptation, mitigation, and resilience principles into the planning, design, construction, and operations of water-related projects.	Mayor's Office	All City Depts.
33	Require Green Street implementation to use sustainable elements and native or climate-appropriate flora compatible with local biomes.	BSS, LASAN	All City Depts.
34	Explore the feasibility of requiring the Sustainable Infrastructure Certification program Envision for large projects and create a program for staff certification.	BOE	All City Depts.
35	Expand education and engagement programs on potable reuse.	LADWP, LASAN	none identified
36	Expand "how to" training and education programs to increase understanding of green infrastructure systems, increase implementation participation, and improve performance.	LASAN	All City Depts.
37	Develop BMP training and certification programs for construction industry and landscape professionals.	BOE	LASAN
38	Develop guidelines for On-site Treatment Facilities (OSTFs) that protect public health and outline wastewater and recycled water systems' operation.	LASAN	LADWP
39	Develop a fee structure and payment guidelines for on-site treatment systems that reflect collection and treatment system impacts and costs.	LASAN	none identified

ES.11 ONE WATER LA IMPLEMENTATION STRATEGY

The Plan's recommendations are a compilation of select projects, programs, and policies developed to identify integration and collaboration opportunities that help achieve the One Water LA Vision, Objectives, and Guiding Principles. These plan recommendations are grouped into the following categories:

- Stormwater Projects (see Section ES.6 for details)
- Wastewater Projects (see Section ES.7 for details)
- Current Integration Opportunities (see Section ES.8 for details)
- Future Integration Opportunities (see Section ES.9 for details)
- Policies and Programs (see Section ES.10 for details)

The following sections summarize the phasing periods, plan recommendations, and funding strategies of the Plan.

ES.11.1 Phasing Periods

The recommended projects and programs identified in the Plan are grouped into three separate phases that cover the 23-year period from 2018 to the planning horizon of 2040. The three project phases identified for the Plan are:

- Near-Term Phase: 2018-2020
- Mid-Term Phase: 2021-2030
- Long-Term Phase 2031-2040

Note that the phasing presented in the Plan is subject to change due to the wide range of uncertainty and factors. Underlying assumptions, system conditions, funding opportunities, and regulatory conditions are also likely to change in the coming decades, which could influence future project needs and implementation.

ES.11.2 Plan Recommendations

The potential fiscal impacts of the Plan's recommendations are summarized in Table ES.3 based on the project category and phasing. The potential fiscal impact of all projects recommended in the Plan is \$13.3 billion.

Table ES.3 Potential Fiscal Impacts for Plan Recommendations Summary Report One Water LA 2040 Plan				
Project Category	Near-Term 2018 - 2020 (\$M)	Mid-Term 2021-2030 (\$M)	Long-Term 2031-2040 (\$M)	Total 2018-2040 (\$M)
Stormwater Projects⁽¹⁾	\$2,538	\$761	\$2,292	\$5,591
Regional Grey	\$106	\$0	\$476	\$582
Regional Green	\$739	\$383	\$1,329	\$2,451
Distributed Green	\$1,693	\$378	\$487	\$2,558
Wastewater Projects⁽²⁾	\$1,030	\$423	\$1,937	\$3,390
Donald C Tillman WRP	\$146	\$121	\$350	\$618
LA-Glendale WRP	\$72	\$75	\$80	\$227
Hyperion WRP	\$106	\$116	\$1,280	\$1,501
Terminal Island WRP	\$65	\$33	\$204	\$303
Collection System	\$641	\$78	\$22	\$741
Current Integration Opportunities⁽³⁾	\$297	\$1,000	\$500	\$1,797
Top 5	\$297	\$0	\$0	\$297
30 Other	\$0	\$1,000	\$500	\$1,500
Future Integration Opportunities⁽⁴⁾	\$85	\$1,090	\$1,350	\$2,525
5 - Dry Weather Low Flow Diversions	\$0	\$110	\$0	\$110
8A - LA River Recharge into LA Forebay	\$0	\$980	\$0	\$980
13 - MBR at HWRP to Regional System	\$0	\$0	\$900	\$900
15 - Donald C Tillman WRP to LAAFP	\$0	\$0	\$310	\$310
17 - LAGWRP to Headworks Reservoir	\$0	\$0	\$140	\$140
22 - East-West Valley Interceptor Sewer	\$85	\$0	\$0	\$85
Policies and Programs⁽⁵⁾	TBD	TBD	TBD	TBD
Total	\$3,950	\$3,274	\$6,079	\$13,303
Notes:				
(1) A complete listing of the Stormwater Improvement Program is included in Appendix D.				
(2) A complete listing of the Wastewater Capital Improvement Program is included in Appendix C.				
(3) A complete listing of the Current Integration Opportunities is included in Chapter 5.				
(4) A complete listing of the Future Integration Opportunities is included in Chapter 6 and Appendix B.				
(5) A complete listing of the prioritized policies, programs, action items, and research ideas are included in Appendix E.				

Note the following regarding the information in Table ES.3.

- The Plan's recommendations are not intended as a city-wide capital improvement plan. Many water-related projects planned to be implemented by individual city departments, without the need for extensive collaboration, are not included.
- The Plan's recommendations include projects from other plans, such as the EWMPs and SCMP. The total estimated cost is thus not an entirely new capital improvement program that would require new funding. Instead, many projects, such as the green streets programs, overlap with the City's previous commitments.
- A large portion of the future integration opportunities consist of major water recycling projects, which also include advanced treatment facilities that would need to be constructed at the City's WRPs. To avoid double-counting, the cost associated with the concept options are only included in the future integration opportunities and not included in the wastewater CIP cost presented in Table ES.3.
- All cost estimates are based on high-level planning assumptions and need to be updated and refined as the planning process evolves from conceptual to design.
- The project layout, timing, and sizing of many of the Plan's recommendations come with significant uncertainty. Some project components might not be implemented within the Plan's planning horizon.
- Due to the current lack of available cost information, the Plan does not include any cost estimates related to implementing policies and programs. A thorough feasibility assessment and cost-benefit analysis for each suggested policy and program is planned so the estimated cost can be included in future Plan updates.

The distribution of potential fiscal impacts by project category is shown graphically on Figure ES.17. As shown, stormwater projects and programs contribute to the largest portion of the total cost (\$5.6 billion or 42 percent), followed by wastewater projects (\$3.4 billion or 25 percent) and future integration opportunities and strategies (\$2.5 billion or 19 percent). The smallest cost category is the current integration opportunities (\$1.8 billion or 14 percent).

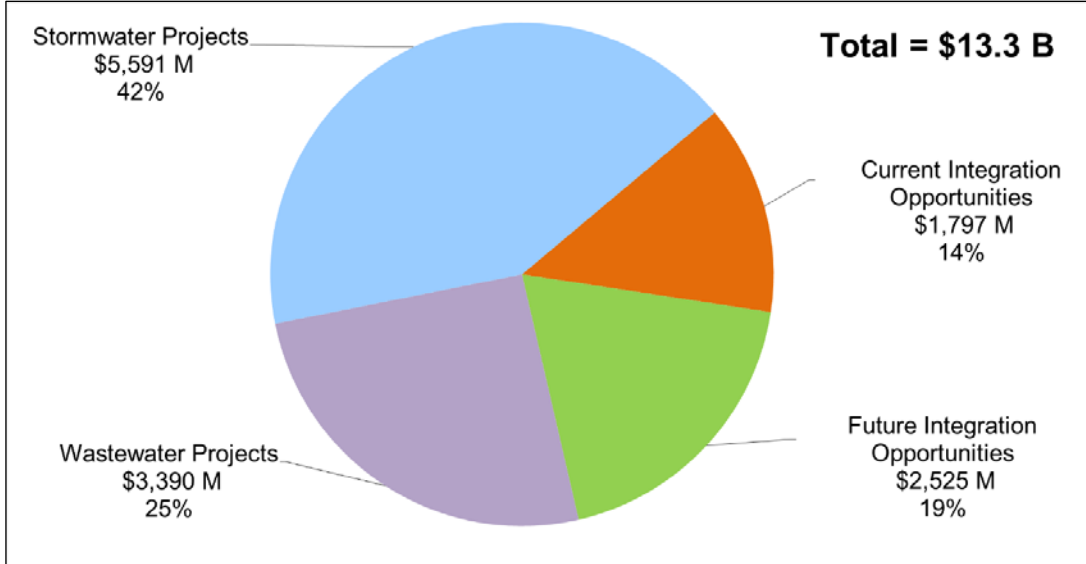

Figure ES.17 Potential Fiscal Impact by Project Category

Given the Plans' adaptive and trigger-based nature, the \$13.3 billion does not necessarily represent a total cost incurred by the City. Instead, it represents the potential fiscal impact of all recommended projects and programs. Because some of these projects may not come to fruition due to trigger monitoring and future conditions, the total cost incurred by the City is likely to differ from the totals presented.

The phasing of potential fiscal impacts by project category is shown on Figure ES.18. As shown, the potential fiscal impact breakdown by phase is as follows:

- \$3.9 billion for the near-term phase
- \$3.3 billion for the mid-term phase
- \$6.1 billion for the long-term phase

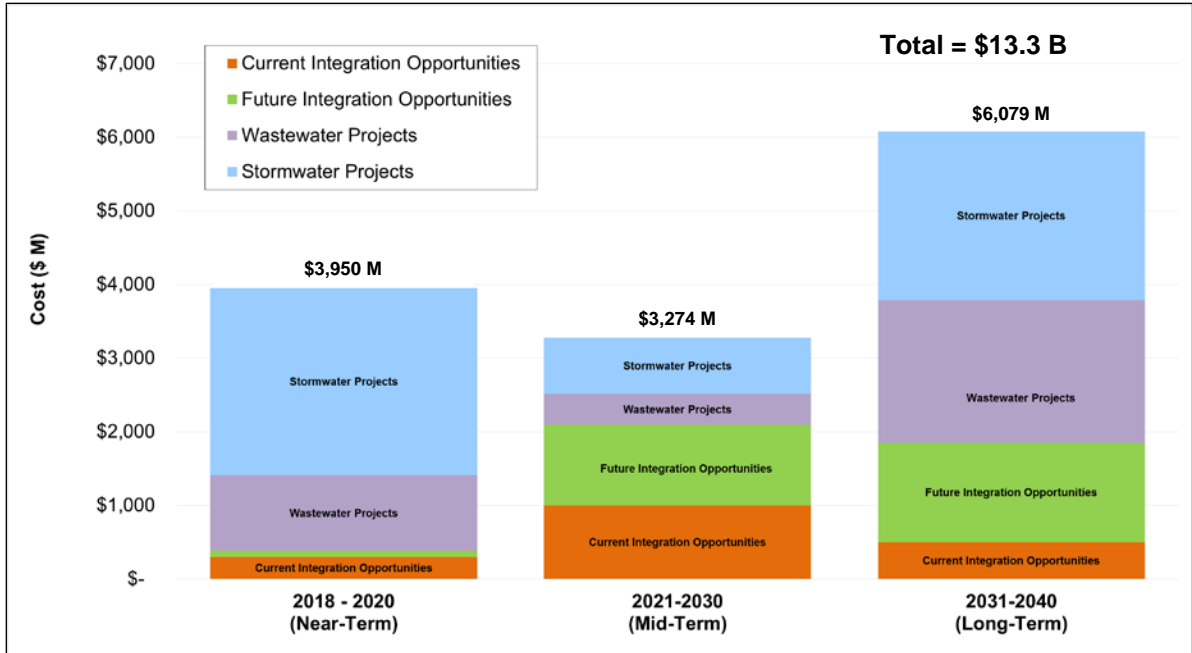

Figure ES.18 Potential Fiscal Impact by Phase and Project Category

In the planning process, several projects might be either infeasible or not required under future circumstances. Furthermore, when reviewing the phasing of projects, programs, and concept options, several events and conditions (known as "triggers") can affect the timing of the recommendations in the Plan.

Due to the complexity and magnitude of the One Water LA 2040 Plan development, a large number of unforeseen conditions and trigger events are possible. As a result, the planned phasing should be considered preliminary and likely to change. Also, phasing the stormwater improvement program (SIP) is heavily front-loaded due to the rapidly approaching TMDL compliance deadlines, which are the primary trigger for most of the SIP projects.

ES.11.3 Funding Needs and Recommendations

The total estimated cost of the projects and programs developed for the Plan is roughly \$13 billion, excluding the recommended policies as noted in Section ES.10. Because a portion of the Plan recommendations supplement the CIPs of individual departments, implementing the Plan would require funding beyond the City's currently planned projects and operations and maintenance (O&M) expenditures.

When the total estimated fiscal impacts of the Plan recommendations is evenly distributed over the next 25 years, the \$13 billion of capital projects equates roughly to \$500 million per year in 2017 dollars, not including the additional O&M costs associated with the new projects. The stormwater improvement program alone is estimated to add another \$250 million in O&M costs annually by 2040. Implementation of these projects will be determined by regulatory requirements, available funding, and resources.

To address the Plan's funding needs, ideas and recommendations were gathered from discussions between City staff and a wide range of stakeholders during the Plan's development. The recommendations related to funding are described in Chapter 10.

ES.11.4 Funding Strategies

The Plan's recommended projects and programs could have access to diverse funding sources. For some funding sources, limitations or restrictions could affect the availability of funding. Consequently, understanding the grants, loans, tax measures, and rate revenue sources available to each participating City department and regional entity provides the first step toward optimizing the use of the sources and selecting the appropriate funding approach.

Departments that participate in the comprehensive One Water LA planning process must also consider how much staff time must be invested. Furthermore, to secure funds, a more involved application and role in dispersing funds are required. Overall, participating agencies must consider their return on the investment that each funding source provides. To provide a foundation for the selection process and approach to pursuing the appropriate source, a list of funding sources available to City departments and regional agencies was compiled. The funding sources include, but are not limited to, the following:

- Existing Utility Revenue
- Voter-Approved Tax Measures (includes Measure A and Measure M)
- Grants and Loan Programs
- Regional Partnerships:
 - Public Private Partnerships
 - Partnerships with private owners and volunteers
- Additional Alternatives

Central to a funding strategy is a discussion of how participating agencies shall fund programs. Due to the integrated nature and regional benefit of the projects identified through One Water LA, many secondary and indirect beneficiaries are anticipated.

Any agency that chooses to receive a benefit and would like to participate in the project may or may not have allocated project costs based on their share of the project benefits. Each participating party's contributions shall be determined on a project- or program-specific basis. Cost-sharing requires a process that will involve some of the following factors:

- Benefits to the respective agency.
- Other secondary partner agencies that might also benefit from the project, either directly or indirectly.
- The ability to participate in and fund the agency's respective share of the program.

As part of the Plan's development, a series of Special Topic Group meetings involved discussing "Funding Strategies." A cost-sharing process was then developed to implement a repeatable and transparent plan for each program or project. The cost-sharing process is shown below, with a more detailed description and considerations for a benefit-based cost allocation of both capital and O&M costs described in Chapter 10.

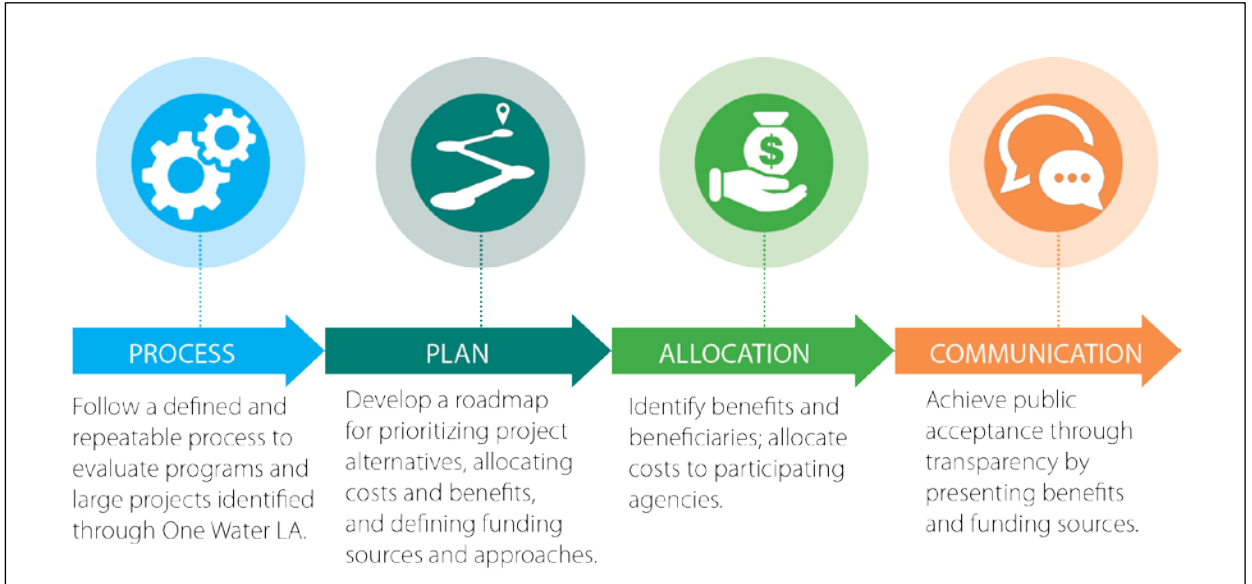

City staff and stakeholders developed a repeatable and transparent cost-sharing process that each program or project could follow.

ES.12 NEXT STEPS

The One Water LA 2040 Plan is intended to be more than a plan – it's a comprehensive strategy for managing water in an integrated way to achieve the One Water LA Vision.

The City will undertake a number of immediate and near-term steps to start implementing the findings and recommendations presented in the Plan. These steps are described below and include the following:

1. Prepare a Programmatic Environmental Impact Report (PEIR).
2. Continue Inter-Departmental Collaboration and Coordination.
3. Continue Stakeholder Engagement and Public Outreach.
4. Further assess and develop policies and programs.
5. Pursue funding strategies to implement the Plan.
6. Complete Future One Water LA Plan Updates and Reporting.

These activities are critical to One Water LA's success, identifying multi-departmental and multi-agency integration opportunities to efficiently, cost-effectively, and sustainably manage water. The One Water LA 2040 Plan represents the City's continued and improved commitment to collaboration and integrated management of all its water resources and implementation of innovative solutions. The Plan will help guide future strategic decisions when prioritizing and implementing integrated water, wastewater, and stormwater infrastructure projects, programs, and policies within the City.



Adel Hagekhalil (LASAN's Assistant Director) and Marty Adams (LADWP's Chief Operating Officer) led the regional collaboration at a VerdeExchange Water Charrette (June, 2017)

The One Water LA 2040 Plan (Plan) is intended to provide a strategic vision and identify collaboration opportunities for integrated water management in the City of Los Angeles (City). Chapter 1 of the Plan's Summary Report introduces the following information:

- Background on the Plan
- An overview of Plan elements and the development process
- One Water LA Vision, Objectives, and Guiding Principles
- A description of how the Plan leverages existing planning efforts
- A description of the Plan outcomes
- An overview of the study area
- The Plan's overall organization
- A summary of the Project Team

Because the Summary Report represents only 1 of 10 volumes in the entire Plan, this chapter primarily describes the Plan's purpose and organization.

1.1 BACKGROUND

In 1999, the City started preparing its first Water Integrated Resources Plan (Water IRP) (Los Angeles Sanitation [LASAN]/Los Angeles Department of Water and Power [LADWP], 2006), beginning a paradigm shift for the City that led to significant achievements after its inception. In 2006, the Water IRP was completed with a planning horizon of year 2020.

Since then, the water landscape in the City has changed drastically. Today, it faces sustainability challenges, new regulations, and the threats of climate change. Some of the most prominent changes have been triggered by the severe statewide drought that began in 2012. Although the drought reduced supply availability and reliability, it resulted in the following key positive changes:

- Tremendous success in water conservation.
- A new way of thinking and more proactive integrated water resource planning.
- A sense of urgency at the state level to finalize indirect potable reuse regulations and develop direct potable reuse (DPR) regulations.

The One Water LA 2040 Plan looked at a wide variety of water-related issues and challenges requiring new integrated water management strategies in the future. These water management challenges are described in more detail in Chapter 3 and are summarized as follows:

- Preparing for more frequent and prolonged drought conditions.
- Meeting stormwater quality regulations.

- Adapting to changing flood management needs.
- Replacing aging infrastructure.
- Preparing for greater water demand.
- Becoming climate change resilient.
- Managing limited funding.

In response to these challenges and to help achieve water sustainability, the City initiated this Plan, which builds on the success of the Water IRP and extends the planning horizon to year 2040. It also takes a holistic and collaborative approach that considers all water resources, from surface water, groundwater, potable water, wastewater, recycled water, dry-weather runoff, and stormwater, as "One Water." The Plan identifies multi-departmental and multi-agency integration opportunities to manage water in a more efficient, cost-effective, and sustainable manner.

The Plan represents the City's continued and improved commitment to proactively manage all of its water resources and to implement innovative solutions driven by the Sustainable City pLAn (2015). Moving forward, it provides a comprehensive strategy for managing water in a more integrated, collaborative, and sustainable way through new project, program, and policy opportunities. Specific water projects, programs, or policies that are the sole responsibility of one agency, including LADWP's aqueduct or groundwater remediation project, are contained in each agency's appropriate plans.

1.2 PLAN ELEMENTS AND DEVELOPMENT PROCESS

The Plan consists of a wide variety of elements and deliverables that bring together the findings of extensive strategic planning, analysis, and studies, all of which were prepared through a stakeholder-driven process (see Chapter 2). The Plan's elements include, but are not limited to, those shown on Figure 1.1.

To date, the One Water LA 2040 Plan development has consisted of two phases, which are described below along with their key purposes and outcomes.

Phase 1 defined the vision, objectives, and guiding principles through active engagement of the One Water stakeholder group, the One Water LA Advisory Group, and One Water Steering Committee. These groups and committees are described in more detail in Chapter 2. Phase 1 resulted in the Guiding Principles Report, which includes the One Water LA Vision, the 7 One Water LA objectives, and 38 guiding principles. The objectives and



Figure 1.1 One Water LA 2040 Plan Elements

guiding principles are summarized in Section 1.3. A detailed summary and description of the development process is provided in the Guiding Principles Report (LASAN, 2015), which is included in Volume 9.

Phase 2 involved developing this One Water LA 2040 Plan. The Plan preparation involved detailed engineering, integrated planning and policy analyses to develop an implementation strategy that met the One Water LA Vision, objectives, and guiding principles. Wastewater and stormwater facility plans were also completed during this phase, and recommended project concepts, policies, and programs were identified to increase coordination, integration, and management of water between all City departments and regional agencies. A series of stakeholder workshops and advisory group meetings gathered input from stakeholders throughout the Plan development.

This Plan is a culmination of Phase 1 and Phase 2.

1.3 ONE WATER LA VISION, OBJECTIVES, AND GUIDING PRINCIPLES

1.3.1 One Water LA Vision Statement

During Phase 1, the One Water LA Vision Statement was developed with extensive input from stakeholders and the One Water LA Advisory Group. The purpose of the Vision Statement is to guide the City through the planning horizon of 2040. The Vision Statement defines the overall purpose of One Water LA and describes what the City aspires to accomplish in the broadest terms, setting the course for future decisions and actions. The One Water LA Vision Statement is defined as follows:

One Water LA is a collaborative approach to develop an integrated framework for managing the City's water resources, watersheds, and water facilities in an environmentally, economically, and socially beneficial manner.

One Water LA will lead to smarter land use practices, healthier watersheds, greater reliability of our water and wastewater systems, increased efficiency and operation of our utilities, enhanced livable communities, resilience against climate change, and protection of public health.

1.3.2 One Water LA Objectives and Guiding Principles

The City, in collaboration with the One Water LA Steering Committee, Advisory Group, and Stakeholder Group, developed 7 objectives and 38 guiding principles to help achieve the One Water LA Vision. These objectives and guiding principles are summarized on Figure 1.2. The guiding principles offer clear direction on desired actions to support the accomplishment of each objective. The objectives and guiding principles are based on stakeholder values and preferences. The guiding principles were created to support the detailed planning that took place during One Water LA Phase 2. They were not intended to define specific targets or mechanisms for project implementation.

The seven One Water LA Objectives are:

- 1) **Integrate management of water resources and policies** by increasing coordination and cooperation between City departments, partners, and stakeholders.
- 2) **Balance environmental, economic, and societal goals** by implementing affordable and equitable projects and programs that provide multiple benefits to all communities.
- 3) **Improve health of local watersheds** by reducing impervious cover, restoring ecosystems, decreasing pollutants in our waterways, and mitigating local flood impacts.
- 4) **Improve local water supply reliability** by increasing capture of stormwater, conserving potable water, and expanding water reuse.
- 5) **Implement, monitor, and maintain a reliable wastewater system** that safely conveys, treats, and reuses wastewater, while also reducing sewer overflows and odors.
- 6) **Increase climate resilience** by planning for climate change mitigation and adaptation strategies in all City actions.
- 7) **Increase community awareness and advocacy for sustainable water** by active engagement, public outreach, and education.

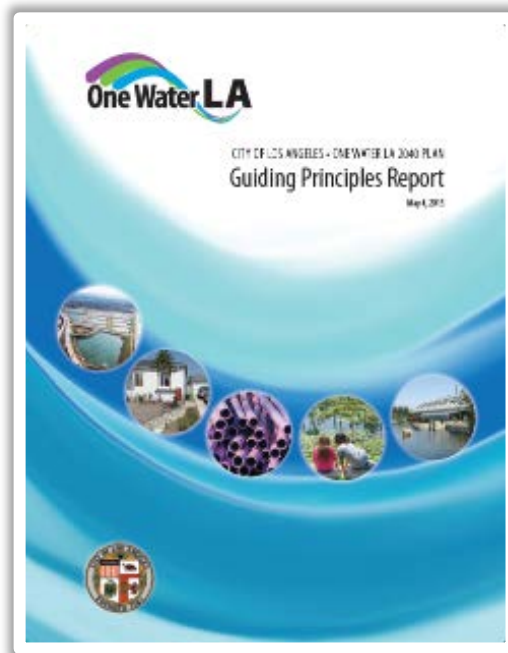

ONE WATER LA GUIDING PRINCIPLES ALIGNED BY OBJECTIVES

1 Integrate management of water resources and policies by increasing coordination and cooperation between all City departments, partners and stakeholders.

- ◆ *Build on the success of the City's Water Integrated Resources Plan and other Mayor and City Council supported water resources plans to advance water sustainability.*
- ◆ *Recognize that water is integral to the actions of City departments and create a framework for integration and collaboration between departments and City Hall.*
- ◆ *Enhance the coordination and partnerships with regional water, transportation, education and other public agencies.*
- ◆ *Engage elected officials and governing boards to support coordination and cooperation to promote integrated management of water resources and policies.*
- ◆ *Enhance coordination with Non-Governmental Organizations, Neighborhood Councils, and other stakeholders to inform integrated planning and broaden community involvement.*
- ◆ *Understand the water balance that summarizes rainfall, runoff, water demands, wastewater flows, and ocean discharges to consider the potential for stormwater capture, water conservation and reuse.*
- ◆ *Continue coordination between City Departments during construction of the City's infrastructure.*

2 Balance environmental, economic and societal goals by implementing affordable and equitable projects and programs that provide multiple benefits to all communities.

- ◆ *Evaluate a "no action" alternative that considers imported water costs, regulatory requirements, water supply reliability, infrastructure reliability, climate change, and other associated risks.*
- ◆ *Develop a transparent process that identifies opportunities for inter-departmental collaboration and cost-sharing based on benefits that are aligned with departmental missions.*
- ◆ *Analyze financial merits of programs using standard financial methodologies.*
- ◆ *Emphasize multi-benefit projects based on measures of social, environmental and economic benefits.*
- ◆ *Partner with academia and private interests to advance measurement of social and environmental benefits and to evaluate new technologies.*
- ◆ *Incorporate environmental justice into decision-making on where projects are implemented and focus on increasing benefits in underserved communities.*
- ◆ *Consider water demands, supply availability, population, regulatory requirements, climate vulnerability, and environmental goals to establish triggers, where appropriate, to plan, implement and/or defer projects.*
- ◆ *Explore private, local, state and federal funding opportunities to implement multi-benefit projects.*

3 Improve health of local watersheds by reducing impervious cover, restoring ecosystems, decreasing pollutants in our waterways and mitigating local flood impacts.

- ◆ *Emphasize upstream solutions in order to mitigate downstream impacts, challenges and costs.*
- ◆ *Support strategies included in LASAN's Enhanced Watershed Management Program (EWMP) Plans and look for opportunities to integrate with LADWP's Stormwater Capture Master Plan, Bureau of Engineering's Flood Management Plan, Green Streets Program, and related updates in order to improve water quality, ecosystem restoration and flood mitigation.*
- ◆ *Align Mayor or City Council supported plans and projects for the Los Angeles River and other significant tributaries within the City with watershed health and other water resources goals.*
- ◆ *Support multi-purpose strategies for reducing impacts of localized flooding, with an emphasis on natural systems and green infrastructure over traditional gray infrastructure*

Figure 1.2 - One Water LA Objectives and Guiding Principles (Page 1 of 2)

One Water LA 2040 Plan
Summary Report



4 Improve local water supply reliability by increasing capture of stormwater, conserving potable water and expanding water reuse.

- ◆ Support recommendations from LADWP's Stormwater Capture Master Plan, LASAN's EWMP Plans, and related updates to increase stormwater capture for water supply.
- ◆ Consider findings from LADWP's Water Conservation Potential Study and related updates to reduce the City's demand for potable water.
- ◆ Improve water sustainability, including water efficiency, water reuse, and stormwater capture, at City facilities and buildings.
- ◆ Explore the use of graywater systems and develop appropriate guidelines for implementation.
- ◆ Support recommendations from the City's Recycled Water Master Planning Documents and related updates to increase non-potable reuse; and indirect potable reuse; and conduct necessary technical, scientific and regulatory evaluations for assessing the potential for direct potable reuse.
- ◆ Recognize the importance of remediating and maintaining the health of the City's groundwater basins and consider recommendations of LADWP's groundwater program.

5 Implement, monitor and maintain a reliable wastewater system that safely conveys, treats and reuses wastewater while also reducing sewer overflows and odors.

- ◆ Optimize the use of existing City assets and infrastructure and explore opportunities for distributed solutions in order to safely convey, treat and reuse wastewater.
- ◆ Optimize water reuse from the City's wastewater system, with particular emphasis on the Hyperion Wastewater Treatment Plant.
- ◆ Optimize recovery and use of nutrients from wastewater and biosolids, and recovery and use of biogases.
- ◆ Seek ways to operate wastewater treatment plants with energy independence.

6 Increase climate resilience by planning for climate change mitigation and adaptation strategies in all City actions.

- ◆ Identify citywide metrics for greenhouse gas emissions and climate change adaptation and mitigation that are used to assess project viability.
- ◆ Consider water-energy-land use nexus (climate adaptation) in the City's General Plan and development zones.
- ◆ Raise the priority of water issues in relevant City plans that impact sustainability, climate adaptation/resiliency, and emergency preparedness.
- ◆ Maximize available state funding and explore financial incentives to reduce greenhouse gas emissions and increase resiliency.
- ◆ Coordinate with regional agencies on water-related climate change mitigation and adaptation strategies.

7 Increase community awareness and advocacy for sustainable water by active engagement, public outreach and education.

- ◆ Explore strategies on how to increase public awareness and education for all water resources issues, with a specific focus on influencing individual behaviors around water use.
- ◆ Expand on current public education programs for water to include climate change impacts and importance of mitigation, adaptation and resiliency.
- ◆ Communicate to neighborhood councils, community groups, and other stakeholders the water related roles, responsibilities, functions, and success stories of each City department.
- ◆ Empower communities and citizens to implement distributed (parcel-scale) solutions within their control to help achieve water sustainability objectives.

Figure 1.2 - One Water LA Objectives and Guiding Principles (Page 2 of 2)

One Water LA 2040 Plan
Summary Report



1.4 LEVERAGING EXISTING PLANNING EFFORTS

One Water LA integrates information developed for numerous existing plans and studies, leveraging a wide variety of existing information. The following section describes the key planning documents, other than the One Water LA Guiding Principles Report, used to develop the Plan.

2006 Water Integrated Resources Plan (Water IRP) –

The Water IRP, adopted in 2006, covers a planning horizon from 2000 to 2020 and represents the first time that wastewater facilities planning was integrated with stormwater, recycled water, and water conservation. This plan was also groundbreaking in its engagement with public stakeholders during the planning process. The Water IRP helped pass Proposition O (Prop O), a \$500 million General Obligation Bond that has funded a number of stormwater and receiving water quality improvement projects in the City since being enacted by the voters in 2004. The Water IRP also identified the Groundwater Replenishment Project in the San Fernando Basin, currently in progress, and a variety of other water projects, programs, and policies.

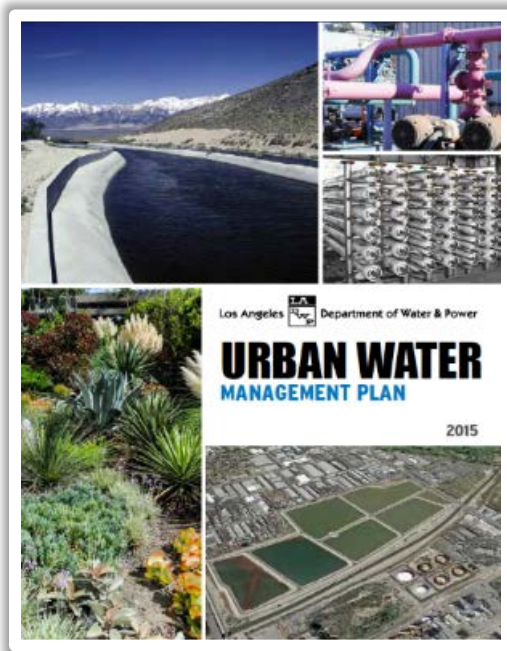
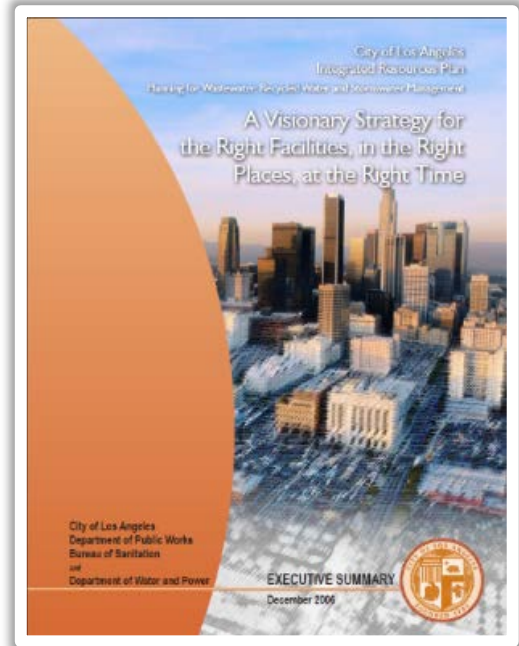

2015 Urban Water Management Plan (UWMP) – Per the Urban Water Management Planning Act, the LADWP updates its UWMP every five years. The main goal of the 2015 UWMP is to plan for meeting all future water demands with water supplies under average and dry-year conditions through year 2040. Additional goals were to identify future water supply projects to meet future demands; update water conservation goals; and develop a single- and multi-year management strategy. The UWMP is the City's master plan for water supply and resources management and guides LADWP's decision-making process to secure a reliable and sustainable water supply for the City. LADWP's 2015 UWMP update provides a strategy for the City to meet the following Sustainable City pLAN (pLAN) goals:

- A 50 percent reduction of purchased imported water by 2025
- A 50 percent local water supply by 2035
- Up to a 25 percent reduction in potable water use by 2035

The UWMP also incorporates the beneficial role of LADWP's San Fernando Basin Groundwater Remediation project by allowing LADWP to further use City investments in groundwater replenishment to facilitate recycled water and stormwater projects.

The Sustainable City pLAn – The pLAn is a comprehensive and actionable directive to produce meaningful results for the City while laying a path to strengthen and transform the City for the future. It addresses the environment, economy, and equity together to move toward a truly sustainable future. In effect, the Sustainable City pLAn sets the course for a cleaner environment and stronger economy, with a commitment to equity. For water, the Sustainable City pLAn calls for a multi-faceted approach to achieving a locally sustainable water supply, reducing per-capita potable water use, scaling back dependence on purchased imported water, maximizing water recycling, and increasing stormwater capture, as shown on Figure 1.3.

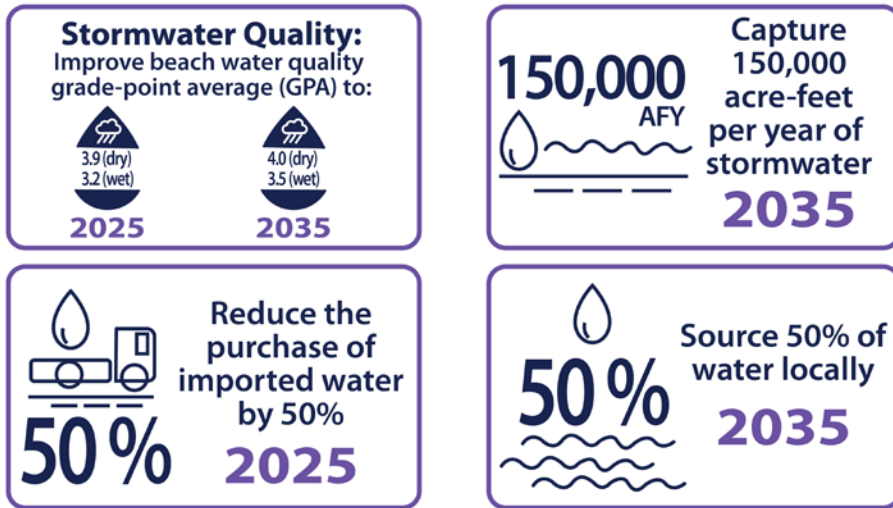
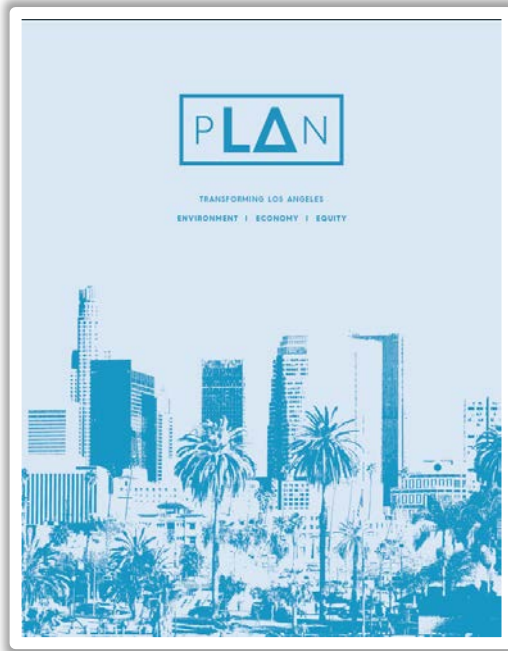
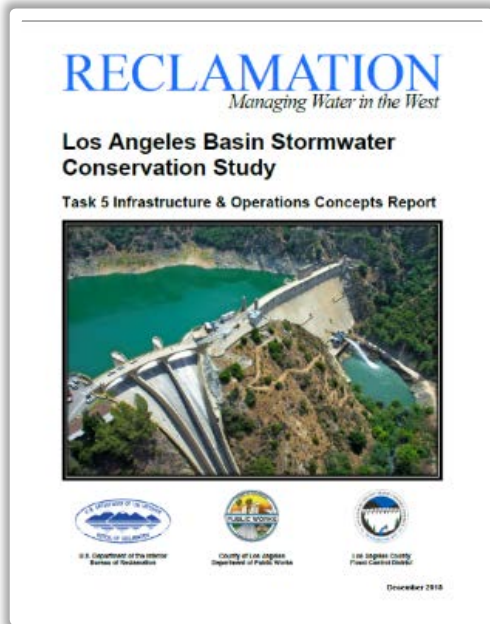

Figure 1.3 Sustainable City pLAn Goals Supported by One Water LA

2015 Stormwater Capture Master Plan (SCMP) – The LADWP SCMP is intended to help reduce the City's dependence on purchased imported water through increased utilization of stormwater as a water supply resource. This master plan outlines strategies for developing projects, programs, and policies to advance centralized and distributed stormwater capture initiatives over the next 20 years. Specifically, the SCMP identifies large-scale stormwater capture projects (such as below-ground stormwater infiltration units) to increase stormwater capture, and evaluates smaller distributed green infrastructure projects (such as bioswales, drywells, rain gardens, and permeable pavement) from a programmatic level. The SCMP will serve as a guiding document for policymakers regarding stormwater capture.



2015 LA Basin Stormwater Conservation Study – The LA Basin Stormwater Conservation Study (US Bureau of Reclamation [USBR], 2015) was prepared by the Department of Interior of USBR in collaboration with the Los Angeles County Department of Public Works (LACDPW) and the Los Angeles County Flood Control District (LACFCD). This study identified alternatives and opportunities to bridge the gap between current and future water supply and demand in the LA Basin watersheds. The following key objectives were identified: evaluate the long-term potential of infrastructure (dams, reservoirs, and spreading grounds) to conserve increased amounts of stormwater for the water supply and analyze the potential for new facilities and operational changes to capture increased stormwater for the water supply.

Enhanced Watershed Management Programs (EWMP) – The National Pollutant Discharge Elimination System (NPDES) MS4 Permit was adopted in 2012. In an effort to protect beaches and marine life, the permit established TMDLs for numerous pollutants, including bacteria, toxics, trash, metals, nutrients, and others. These TMDLs were key drivers for the development of the EWMPs. The City was involved in the preparation of five different EWMPs as its service area overlays portions of five different watersheds, which are shown on Figure 1.4. The EWMPs identify stormwater quality improvement needs to meet various TMDL pollutant loading and compliance deadlines that vary by watershed.

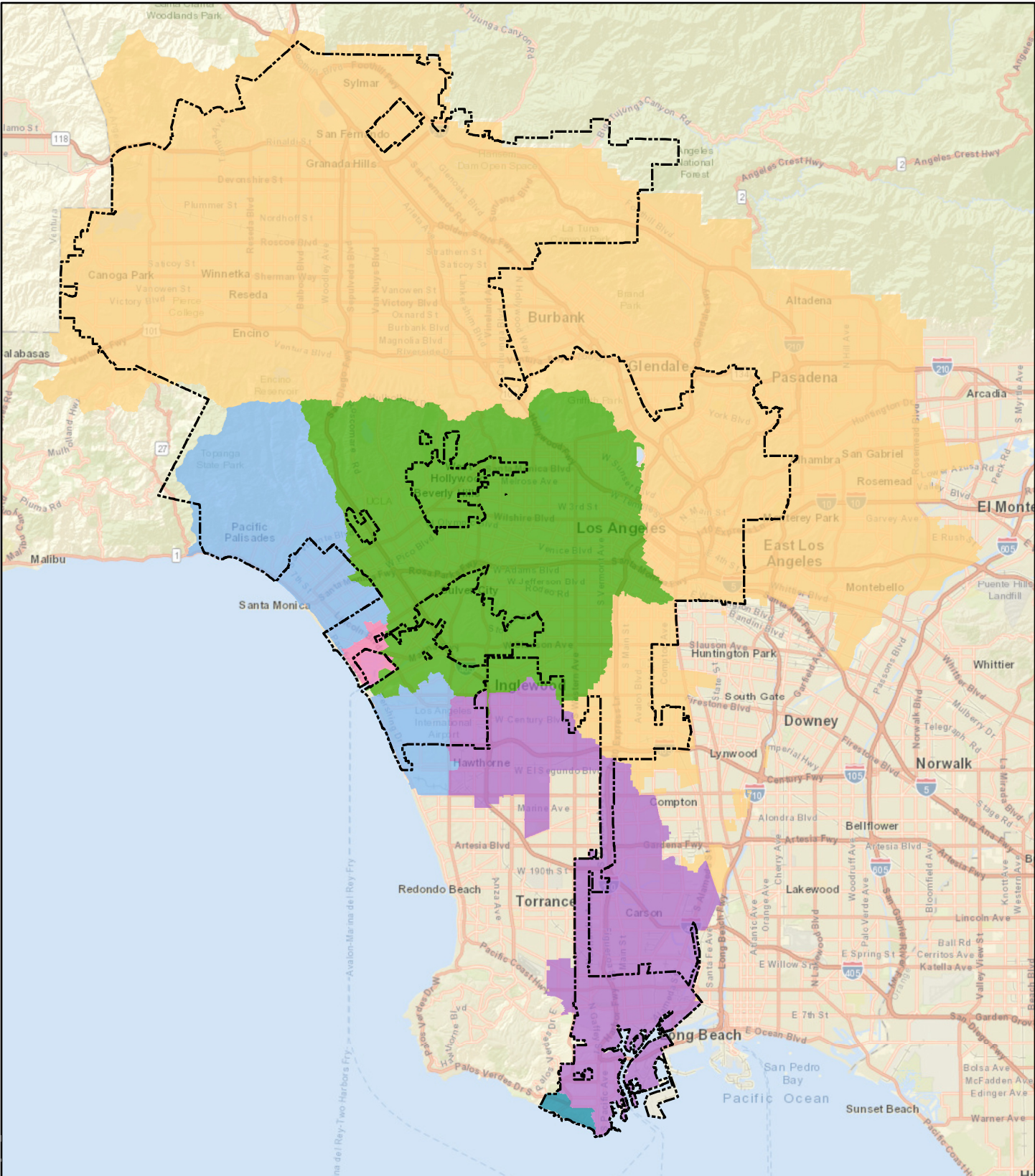

Legend

- City of Los Angeles
- Marina del Rey
- EWMP Boundary**
- Ballona Creek
- Santa Monica Bay J23
- Dominguez Channel EWMP
- Santa Monica Bay J7
- Upper Los Angeles River



0 2.5 5 Miles

Figure 1.4 - EWMP Boundaries
One Water LA 2040 Plan
Summary Report



The City collaborated with nearly 30 other government agencies to prepare an EWMP for each of the five watersheds in Los Angeles County. This effort was carried out to prioritize water-quality issues and identify implementation strategies, control measures, and Best Management Practices (BMPs) so the County can meet pertinent receiving water limitations and water-quality based effluent limits (LASAN, 2015). The five EWMPs that collectively cover the City of Los Angeles are described in the following section.

Upper Los Angeles River Watershed EWMP – This EWMP addresses the stormwater quality improvement needs of the 485 square miles area of the Upper LA River watershed and 55 miles of mainstream LA River from its headwaters to just above the estuary. Major tributaries include Aliso Canyon Creek, Bell Creek, Bull Creek, Tujunga Wash, Burbank Western Channel, Arroyo Seco, Rio Hondo, and Compton Creek. Major water bodies include Reaches 2-6 of the LA River (described in Chapter 3), Lake Calabazas, Echo Park Lake, and Legg Lake. The EWMP Group consists of the cities of Los Angeles, Alhambra, Burbank, Calabasas, Glendale, Hidden Hills, La Canada Flintridge, Montebello, Monterey Park, Pasadena, Rosemead, San Fernando, San Marino, South El Monte, South Pasadena, and Temple City, as well as the County of Los Angeles (Unincorporated County) and the LACFCD.

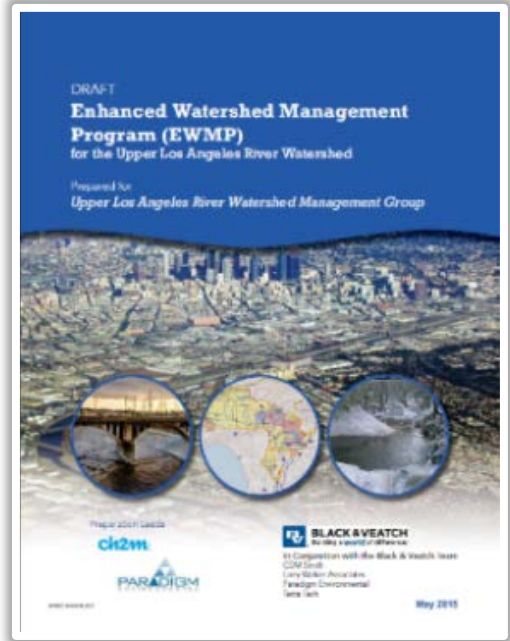

Ballona Creek Watershed EWMP – This EWMP addresses the stormwater quality improvement needs of the 128 square miles area that contains tributaries to Ballona Creek, including Sepulveda Canyon Channel and Centinela Creek. Other water bodies include the Del Rey Lagoon and Ballona Wetlands. The EWMP Group consists of the cities of Beverly Hills and West Hollywood and portions of the cities of Los Angeles, Inglewood, Culver City, and Santa Monica, as well as the County of Los Angeles (Unincorporated County) and the LACFCD.

Santa Monica Bay Watershed EWMP – This EWMP addresses the stormwater quality improvement needs of the 39 square miles area that includes the Santa Monica Bay and the land area that drains into it. Water bodies include Santa Ynez Canyon, La Pulga Canyon, Temescal Canyon, Santa Monica Canyon, and Santa Monica Bay. The EWMP Group consists of the cities of Los Angeles, Santa Monica, and El Segundo, as well as the County of Los Angeles and LACFCD.

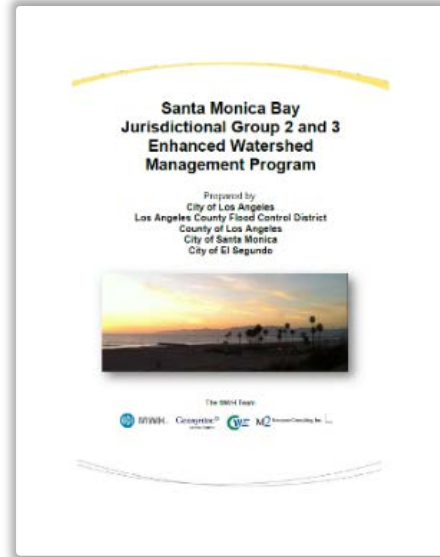

Marina Del Rey Watershed EWMP –

This EWMP addresses the stormwater quality improvement needs of a small sub-watershed located in the larger Santa Monica Bay Watershed, with a tributary area of 1,409 acres (2.2 square miles). It includes the Marina del Rey Harbor. The EWMP Group consists of portions of the cities of Culver City and Los Angeles, as well as the County of Los Angeles (Unincorporated County).

Dominguez Channel Watershed EWMP –

This EWMP addresses the stormwater quality improvement needs of the 133 square miles area of land and water in the southern portion of Los Angeles County. It includes the Dominguez Channel Watershed, Machado Lake Watershed, and the Los Angeles/Long Beach Harbors Watershed. The EWMP Group consists of the cities of El Segundo, Hawthorne, Inglewood, Lomita, and Los Angeles, as well as the County of Los Angeles (Unincorporated County) and the LACFCD.

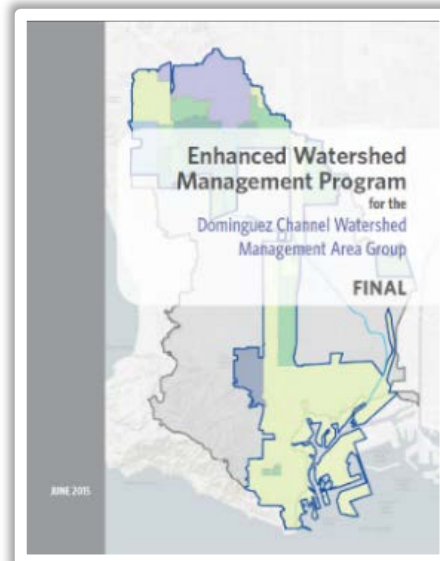

Other Planning Documents

Other planning documents used to develop this Plan include, but are not limited to, the following:

- Beneficial Uses of Inland Surface Water (Los Angeles Regional Water Quality Control Board, Accessed 2014)
- California Climate Change Assessments (State of California, Accessed 2016)

- Climate Change Impacts in the United States: The Third National Climate Assessment (Melillo, Richmond, Yohe, 2014)
- Colorado River Basin Water Supply and Demand Study (Bureau of Reclamation, 2012)
- Executive Directive No. 5 (ED#5): Emergency Drought Response - Creating a Water Wise City (City of Los Angeles, 2015)
- LA River Ecosystem Restoration Integrated Feasibility Report (U.S. Army Corps of Engineers [USACE], 2015)
- LA River Master Plan (Los Angeles Department of Public Works, Parks and Recreation and Regional Planning, 1996)
- LA Sustainable Water Project: Los Angeles River Watershed Report (University of California – Los Angeles, 2017)
- Los Angeles Region Framework for Climate Change Adaptation and Mitigation Current State of Knowledge & Water Quality Regulatory Program Considerations (Smith, Gallon, 2015)
- Sacramento and San Joaquin Rivers Basin Study (Bureau of Reclamation, 2016)
- Safeguarding California: Implementation Action Plans (Natural Resources Agency, 2016)
- Safeguarding California: Reducing Climate Risk (Natural Resources Agency, 2014)
- Sea-Level Rise for the Coasts of California, Oregon, and Washington: Past, Present, and Future (National Research Council, 2012)
- Sun Valley Watershed Management Plan (LACDPW, 2004)

The Plan integrates existing planning efforts by incorporating the wealth of information, data, and results from corresponding reports. In addition to the plans listed above, many other strategic plans, studies, and documents were used to prepare the Plan. A complete list of reference documents is provided in Appendix A.

1.5 PLAN OUTCOMES

The Plan provides a strategic vision and a collaborative approach to integrated water management through year 2040. Key outcomes include:

- Identification of current and future water-related integration opportunities among City departments, regional agencies, and other stakeholders.
- Identification of strategies and concept options to maximize potable reuse opportunities. Concept options are proposed projects that have been evaluated at the conceptual level and will be considered further in the future.
- Identification of strategies and projects to maximize stormwater capture that considers water quality, flood mitigation, and water supply benefits.
- Policy and program recommendations that help achieve the One Water LA Vision and Objectives.

- Identification of funding sources and mechanisms to further implement the projects, programs, and policies recommended in the Plan.
- Increased stakeholder awareness about the City's water challenges, ongoing collaboration activities, and long-term water management strategies to become a more water-resilient city.
- Increased collaboration between various City departments and regional agencies on water-related projects, programs, and policies due to strengthened and new relationships developed during the One Water LA planning process.

1.5.1.1 Integrated Urban Water Cycle

Within the One Water paradigm, all of the City's water sources are linked through the urban water cycle. In the urban water cycle, rain becomes stormwater, which infiltrates into the groundwater basin or becomes urban runoff. Groundwater is pumped for use as potable water. Once water is used in homes and businesses, it is discharged as wastewater, before being treated and reused as recycled water or discharged to the ocean. The Plan identifies projects, programs, and policies to enhance the City's urban water cycle to increase water recycling and stormwater capture opportunities and minimize losses to the ocean while reducing reliance on purchased imported water.



The City has a vision for its urban water cycle that maximizes opportunities to achieve a sustainable One Water future for all Angelenos, as shown on Figure 1.5. Key long-term initiatives to optimize and enhance the urban water cycle include:

- Increasing stormwater capture and recharge in the aquifers through distributed green infrastructure projects and programs.
- Increasing stormwater capture, treatment, and reuse at parcel, neighborhood, sub-watershed, and regional levels.
- Increasing use of the groundwater basins for storage through new recharge projects.
- Expanding recycled water for irrigation, commercial, industrial, and groundwater recharge uses.
- Balancing the City's water supply needs with environmental needs, such as preserving the LA River ecosystem.
- Exploring potential potable reuse options using advanced treated wastewater at each of the City's four water reclamation plants (WRPs).

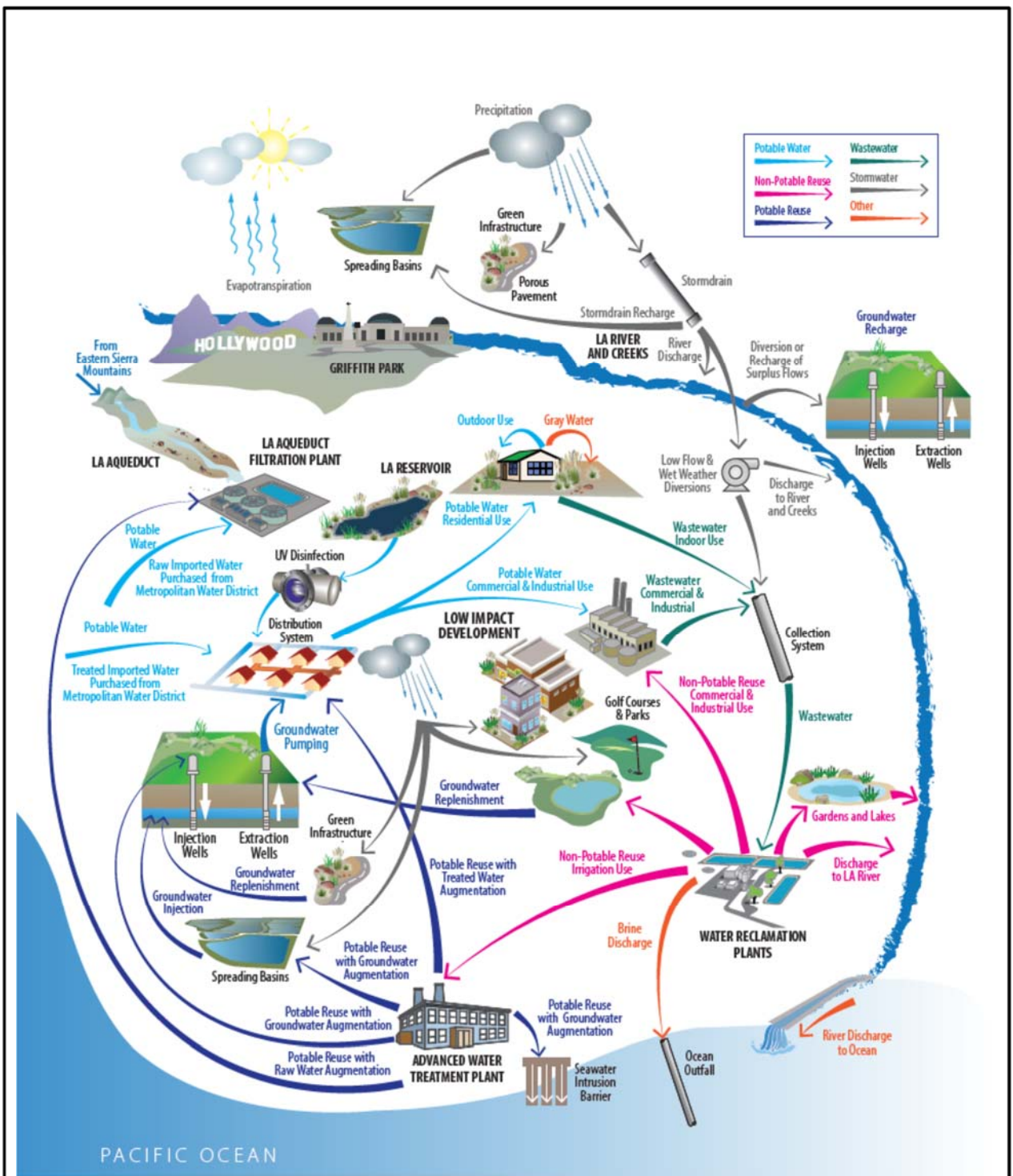

Figure 1.5 - Los Angeles' Future Smart Urban Water Cycle
 One Water LA 2040 Plan
 Summary Report

1.5.1.2 Integration Outcomes and Momentum

The One Water LA team has discussed the City's challenges in water integration, project opportunities, and potential partnerships with City departments and regional agencies to establish a better understanding of how water connects projects, programs, and policies. Discussions were, and continue to be held on how water interfaces with each group's projects and programs and how their studies and designs could manage water differently. Through these interactions, many One Water LA partners have had moments of enlightenment, realizing that water is not ancillary, but an integral component of their designs and practices. City departments and regional agencies immediately started implementing planning, pre-design, and design approaches in their policies, projects, and programs. The key successes and outcomes from the One Water LA team's ongoing participation in multiple efforts are summarized in Table 1.1.

Table 1.1 One Water LA's Impact on Water Integration Summary Report One Water LA 2040 Plan		
Department or Agency	Projects, Programs, or Policies	Water Integration Enhancements
Bureau of Engineering (BOE)	Recycled Water in Concrete; Climate Resiliency; ENVISION; Permitting	<ol style="list-style-type: none"> 1. Evaluating climate resiliency needs in infrastructure designs. 2. Updated engineering specifications allowing recycled water use in all concrete mixes. This includes concrete for sidewalks. 3. BOE cross-training other departments, including LASAN, on the use of ENVISION in planning, pre-design, design and construction process; 4. Streamlined permitting process and decreased fees for Stormwater management projects in the public right of way
Bureau of Street Services (BSS)	Street Tree Selection Guide; Permitting	Climate change impacts and resiliency are now considered when selecting trees (e.g. fewer trees will die due to the increase in number of hot days and temperatures).
Department of City Planning (DCP)	Re:Code LA; Industrial Land Use Pilot (Clean Up Green Up); General Plan Update (OurLA2040); Coastal Commission Study	<ol style="list-style-type: none"> 1. Updated codes and ordinances for integrated Stormwater, Recycled Water, and Climate Change related measures. Decisions and updates made by using One Water LA maps, such as: <ol style="list-style-type: none"> a. Aquifer, Soil Classification, and Stormwater Infiltration Maps b. Recycled Water Distribution Maps c. Climate Change Threat Maps (flood zones, fire zones, etc.) 2. Used One Water LA's recommendations for Industrial Ordinance for improved water conservation and stormwater capture.

Table 1.1 One Water LA's Impact on Water Integration Summary Report One Water LA 2040 Plan		
Department or Agency	Projects, Programs, or Policies	Water Integration Enhancements
General Services Department (GSD)	City-owned facilities and water use	<ol style="list-style-type: none"> 1. Examining and reconsidering operations and maintenance activities for all City facilities to minimize water consumption 2. Provided feedback for better water management of City facilities
Los Angeles Zoo (LA Zoo)	20-year Master Plan; New Event Center	<ol style="list-style-type: none"> 1. Evaluating the use of recycled water in lieu of potable water for LA Zoo operations and exhibit use, including: <ol style="list-style-type: none"> a. Washdown (animal holding areas, walkways, etc.) b. Irrigation and Restrooms c. Exhibits (treatment systems, ponds, aesthetics, etc.) 2. Considering the implementation of water education at LA Zoo entryway, water and island exhibit, and California exhibit/zone. 3. Designing Stormwater infiltration and capture projects for on-site use throughout the Zoo
High Speed Rail (HSR)	Alignments; Partnerships; Union Station	<ol style="list-style-type: none"> 1. Modifying HSR designs and specifications for decreased water consumption, stormwater infiltration, and recycled water use. 2. Reviewing LA River connection in designs 3. Considering Climate resiliency infrastructure design elements 4. Using One Water LA resources, such as: Maps (recycled water distribution, aquifers, climate resiliency), recycled water in concrete report, climate change resilient tree list.
LA County Department of Public Works (LACDPW), LA County Flood Control District (LAFCD)	LA River; Stormwater Facilities	<ol style="list-style-type: none"> 1. Increased coordination on projects and policies 2. Identified shared resources within the City for county-wide stormwater projects, including the LA River, and opportunities for funding and cost-sharing opportunities.
Los Angeles Unified School District (LAUSD)	Integrated Stormwater project	Developing a joint water quality improvement and stormwater capture and infiltration project that helps achieve water quality permit requirements for both entities while also augmenting local water supply.
Port of Los Angeles (POLA)	Innovative projects and technologies	Evaluating all new projects for stormwater infiltration to improve water quality.

Specific changes in business practices identified in Table 1.1 demonstrate the impact of the One Water LA team's collaborative efforts.

1.5.1.3 **Planning for a More Water-Resilient Future**

To achieve a smarter urban water cycle and become a more water-resilient city, there are many projects, programs, and policies that will need to be implemented in the coming decades. LADWP's 2015 Urban Water Management Plan (UWMP) already addresses multiple new strategies in the future smart urban water cycle. The Plan identifies additional integration opportunities that could be implemented by year 2040 and beyond.

The One Water LA 2040 Plan recommendations focus primarily on water-related projects and programs that require multi-departmental and multi-agency coordination and collaboration. The recommendations consist of select projects, programs, and policies developed to further integrate opportunities that help achieve the One Water LA Vision, Objectives, and Guiding Principles.

1.6 **STUDY AREA DESCRIPTION**

This section describes the study area, including a brief overview of its geography and climate, watersheds, groundwater basins, sewersheds, and potable water service area.

1.6.1 **City of Los Angeles**

Although the Plan focuses on water management improvements within the City of Los Angeles' boundaries, its sphere of influence extends beyond them. As shown on Figure 1.6, the City boundary extends from the San Gabriel Mountains in the north to the Pacific Ocean in the west and south, encompassing an area of about 472 square miles inhabited by approximately 4 million people. As noted in the Sustainability City pLAn, the City's population is projected to increase by 500,000 residents by the year 2040.

1.6.2 **Geography and Climate**



The City lies on a hilly coastal plain that stretches from the San Gabriel Mountain foothills to the south and east to the Pacific Ocean, which forms the City's southern and western boundaries. The Santa Monica Mountains create a geographical separation between the San Fernando Valley to the north and Downtown Los Angeles, the Westside, and South Los Angeles to the south. In addition, the City is characterized by a long, narrow stretch of land along Interstate 110 (I-110) that reaches the Los Angeles Harbor at the southernmost edge of the City. The City has five major watersheds within its boundaries, namely: the LA River, Ballona Creek, Dominguez Channel, Santa Monica Bay, and Marina del Rey watersheds. These watersheds are shown on Figure 1.4 and Figure 1.6.

Los Angeles has a mild, Mediterranean climate, with an average monthly maximum temperature of 75 degrees Fahrenheit. Precipitation typically occurs between October and April with rainfall rarely occurring during the summer. As a result, the precipitation totals for water year 2016 occurred from October 1, 2015, through September 30, 2016.

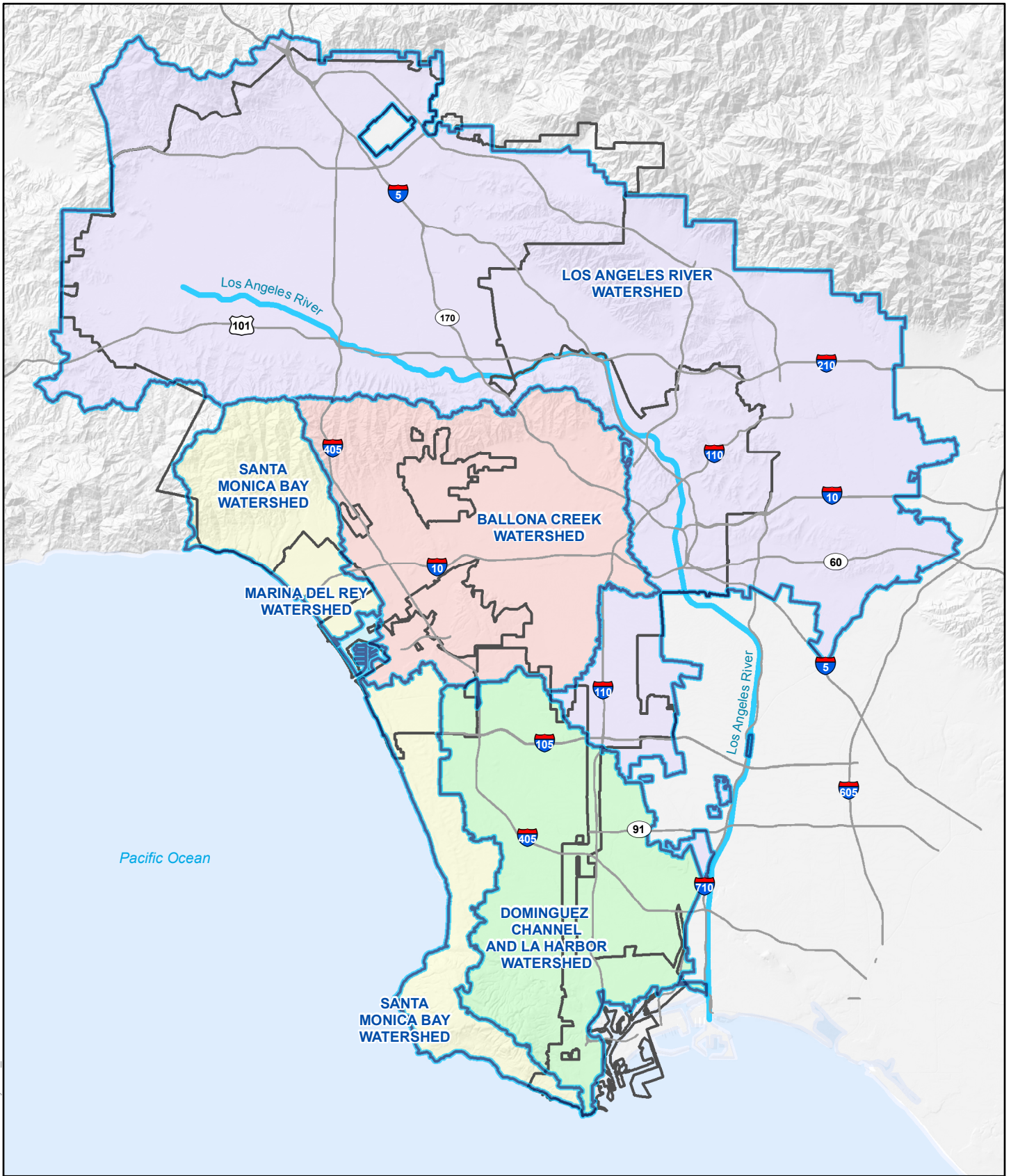
Total precipitation in Downtown Los Angeles averages approximately 14.25 inches per year (LADWP, 2015). This amount varies slightly across the City, with higher precipitation volumes generally occurring at higher elevations or inland areas, and less precipitation generally occurring in lower elevations or coastal areas. Rainfall is either evapotranspired, infiltrated into the ground, or it becomes runoff.



Legend

-  City of Los Angeles
-  Watersheds
Source: LASAN

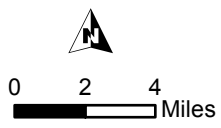

Hillshade Source: CalAtlas
<http://www.atlas.ca.gov>

**Figure 1.6
 Watersheds**

One Water LA 2040 Plan
 Summary Report

1.6.3 Watersheds

The City overlays five major watershed areas that, in general, drain water from outside the City's boundaries into the City, where it infiltrates the underlying groundwater aquifers, gets discharged to the major rivers and streams, or discharges directly to the ocean. These watersheds are shown on Figure 1.4 and Figure 1.6 and are described in Section 1.4 of the EWMP discussion. Additional details on the watersheds are provided in Volume 3.

1.6.4 Groundwater Basins

The City also overlays eight groundwater basins, shown on Figure 1.7, that partially extend beyond the City boundary: San Fernando, Sylmar, Verdugo, Eagle Rock, Hollywood, Santa Monica, West Coast, and Central. Note that other basins shown on Figure 1.7 are for geographical reference only.

As shown on the figures, the largest basin, in terms of both size and groundwater production, is the San Fernando Basin, which is located north of the Santa Monica Mountains. This basin is an important local water supply source for the City, providing up to 92 percent of the City's local groundwater supply. The other three groundwater basins that underlie the northern part of the City are the Sylmar Basin, Verdugo Basin, and Eagle Rock Basin.

The four additional groundwater basins which are also located within the Los Angeles Coastal Plain are the Hollywood Basin, Santa Monica Basin, West Coast Basin, and Central Basin. Key characteristics of these groundwater basins and the agencies that utilize or manage them are discussed in Chapter 3.

1.6.5 Potable Water Service Area



The City's potable water service area closely mirrors that of the City boundary, encompassing approximately 474 square miles, which is only 2 square miles (0.4 percent) greater than the City's jurisdictional service area. LADWP's water system supplied drinking water to over 4 million customers, with nearly 167 billion gallons of treated water sales occurring in FY 2014-2015.

Typically, the LADWP divides the water service area into the following five potable water service areas:

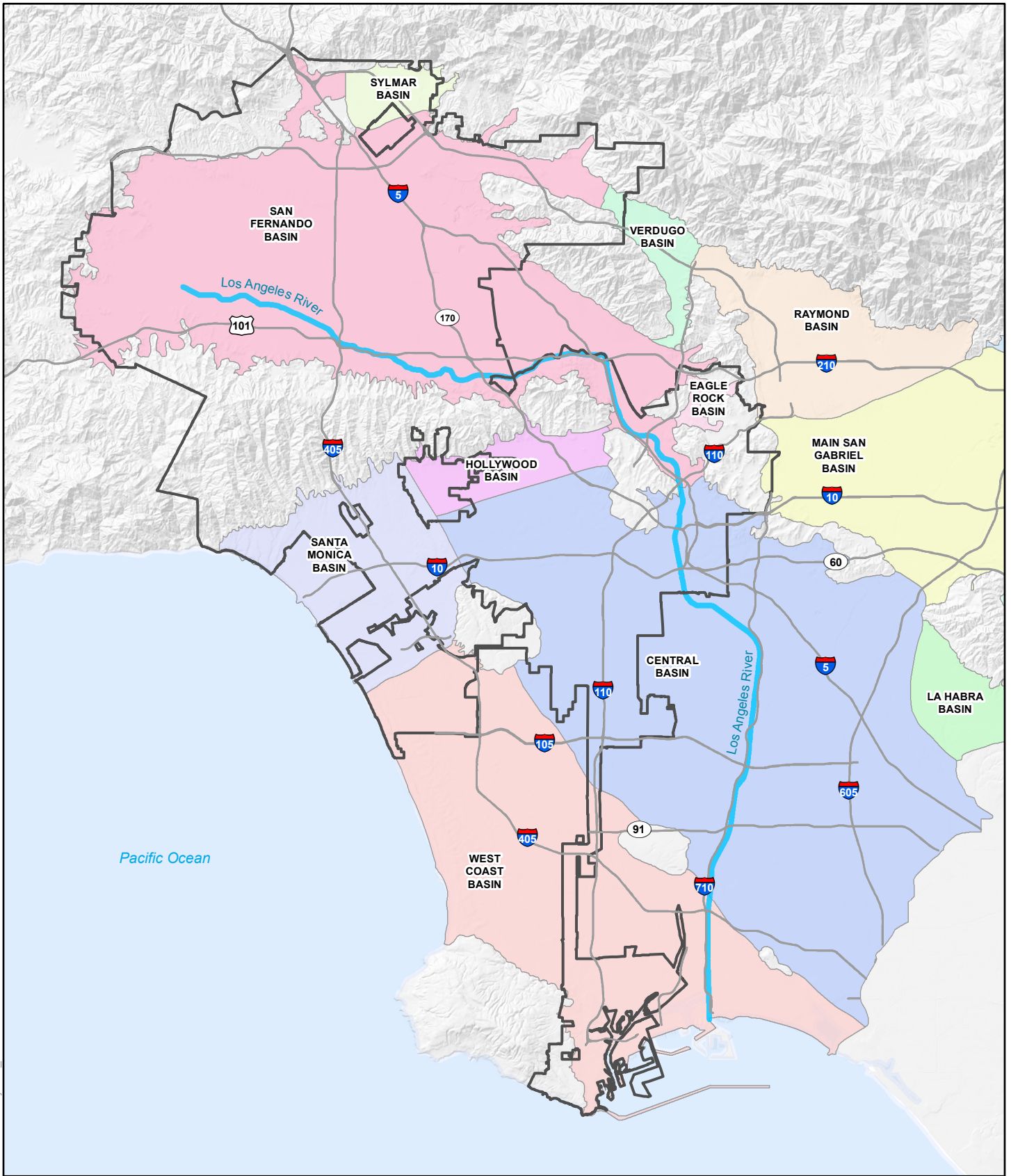
- San Fernando Valley
- Western Los Angeles
- Central Los Angeles
- East Los Angeles
- Harbor



Legend

-  City of Los Angeles
-  Groundwater Basin
Source: LACDPW

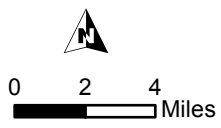

Hillshade Source: CalAtlas
<http://www.atlas.ca.gov>

**Figure 1.7
 Groundwater Basins**

One Water LA 2040 Plan
 Summary Report

Due to topography, most of the City's water distribution system can be supplied by gravity from the Los Angeles Aqueduct Filtration Plant (LAAFP), which is located in the northern end of the City at an elevation of 1,500 feet above mean sea level (MSL). Multiple key reservoirs and transmission lines serve to transport water from north to south, from the Valley to the Harbor. From there, water can reach nearly all areas by gravity, except for portions of Eagle Rock, Highland Park, Mount Washington, and the Harbor. As a result, distributing potential new water supplies from areas at lower elevations will require distribution system enhancements, since the current system is primarily designed to move water from north to south.

1.6.6 Wastewater Service Area and Sewersheds

LASAN owns the City's sewer collection and treatment system. The City's wastewater service area consists of two distinct drainage basin areas: the Hyperion Service Area (HSA) and the Terminal Island Service Area (TISA). The HSA covers approximately 515 square miles and serves the majority of the Los Angeles population. In addition, the service area includes 29 non-city agencies that contract with the City for wastewater service, as shown on Figure 1.8. (In the figure, lighter colors correspond to contract agencies.)

The TISA is approximately 18 square miles and serves the Los Angeles Harbor area. The two service areas are connected by a strip of land extending from South Los Angeles to the City boundary in the harbor area. The Los Angeles County Sanitation Districts (LACSDs) provide wastewater service to the strip of land connecting both service areas.

The wastewater service area is divided into the following seven tributary areas, or sewersheds:

- DCTWRP Sewershed
- Valley Spring Lane Sewershed
- Forman Sewershed
- LAGWRP Sewershed
- HWRP-Metro Sewershed
- HWRP-Coastal Sewershed
- TIWRP Sewershed

As shown on Figure 1.8, the conveyance system routes sewage from City customers and the 29 contract agencies to four different water reclamation plants (WRPs): the Donald C. Tillman Water Reclamation Plant (DCTWRP), Los Angeles-Glendale Water Reclamation Plant (LAGWRP), Hyperion Water Reclamation Plant (HWRP), and Terminal Island Water Reclamation Plant (TIWRP).

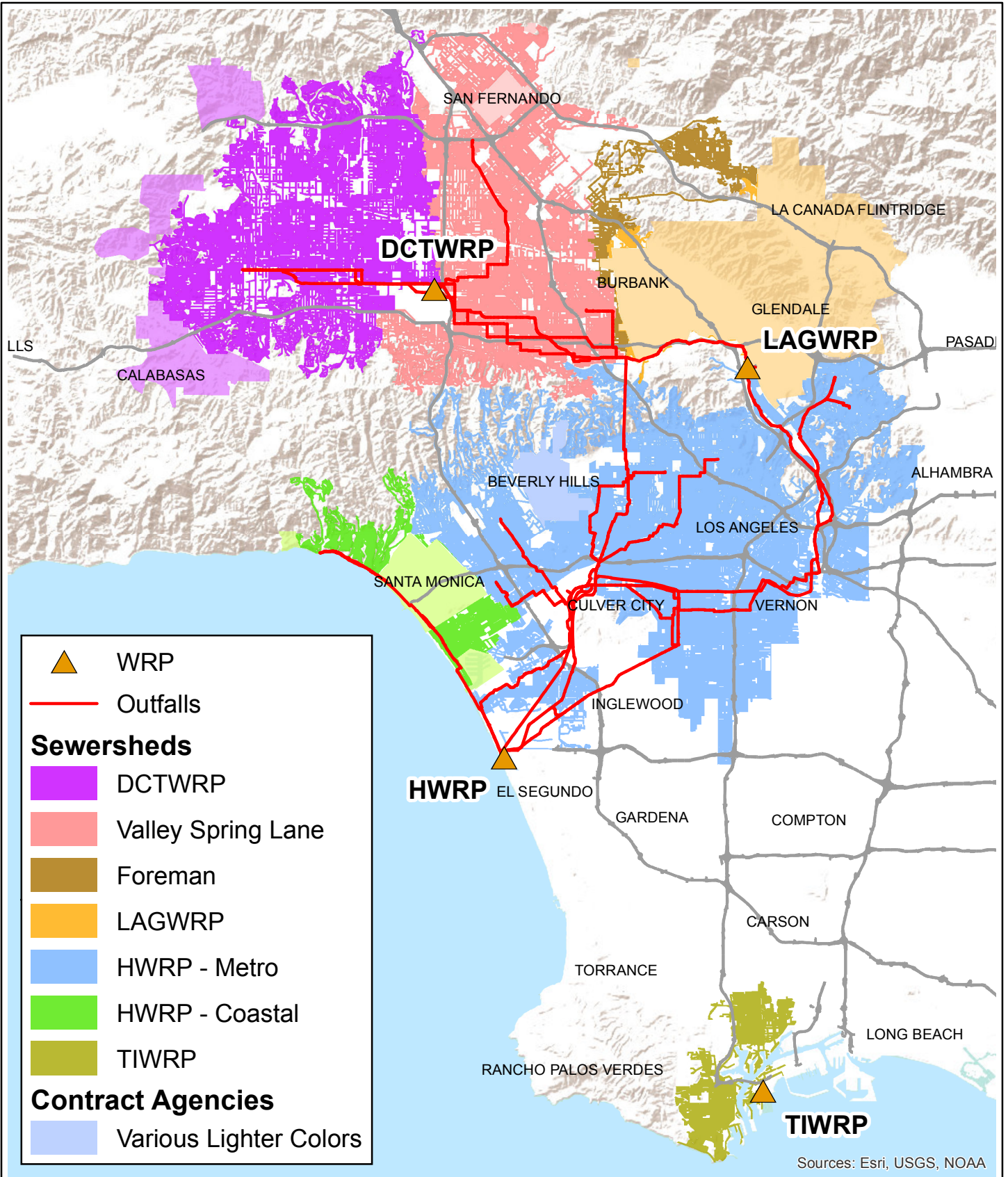
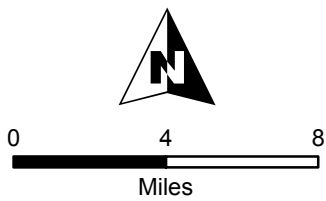

Figure 1.8
City Sewage Service Area
 One Water LA 2040 Plan
 Summary Report



1.7 PLAN ORGANIZATION

The Plan is organized into 10 volumes, with this Summary Report serving as Volume 1. The remaining nine volumes contain more detailed information, plans, and studies. Each volume includes supporting documentation that corresponds to the report volume's technical topic. At the time the Plan was published, it was available in its entirety, except for Volume 10, Programmatic Environmental Impact Report (PEIR). This volume is anticipated to be completed in 2019.

Volume 1: One Water LA 2040 Plan

- Executive Summary
- Chapter 1: Introduction
- Chapter 2: Plan Collaboration and Public Engagement
- Chapter 3: Existing Water Management Strategies
- Chapter 4: Flows and Demands
- Chapter 5: Current Integration Opportunities
- Chapter 6: Future Integration Opportunities
- Chapter 7: Wastewater Facilities Plan
- Chapter 8: Stormwater & Urban Runoff Facilities Plan
- Chapter 9: Plan Recommendations and Implementation Strategy
- Chapter 10: Funding Needs and Next Steps
- Appendix A: References
- Appendix B: Future Integration Opportunities
- Appendix C: Wastewater Projects
- Appendix D: Stormwater Projects
- Appendix E: Policies and Programs

Volume 2: Wastewater Facilities Plan

Volume 3: Stormwater & Urban Runoff Facilities Plan

Volume 4: LA River Flow Study

Volume 5: Integration Opportunities Analysis Details

Volume 6: Climate Risk and Resilience Assessment for Wastewater and Stormwater Infrastructure

Volume 7: Implementation Strategy Supporting Documents

Volume 8: Technical Support Materials

Volume 9: Stakeholder Engagement Materials

Volume 10: Programmatic Environmental Impact Report

1.8 PROJECT TEAM

The Plan was developed by dedicated representatives from both LASAN and LADWP and was shaped with input from other City departments and regional agencies. A Steering Committee, Advisory Group, and a large number of stakeholders also contributed significantly, as described in Chapter 2.

Carollo Engineers, Inc. was the Prime Consultant responsible for developing the Plan. Many other subconsultants also helped with this effort, providing a wide range of technical expertise, administrative support, and guidance with stakeholder engagement and workshops and meetings.

Due to the magnitude of this Plan, not all parties can be listed. However, an acknowledgments list with all key individuals involved in the preparation of this Plan is included in the front of this Summary Report (following the title page). Additionally, the Project Team organization chart, which reflects participants at the end of the project, is provided in TM 1.1 of Volume 7.

-This Page Left Blank Intentionally-

PLAN COLLABORATION AND STAKEHOLDER ENGAGEMENT

Chapter 2 describes the collaboration and stakeholder engagement that took place during development of the One Water LA 2040 Plan (Plan). Development of this Plan depended on close collaboration between City departments and regional agencies to break down the traditional institutional barriers between the management of drinking water, wastewater, recycled water, and stormwater. By integrating the different City departments' projects, adjusting policies, and taking advantage of similar project goals, the City formulated a long-term strategy to improve watershed health, enhance water supply, increase climate resilience, enhance City efficiency, maintain a reliable wastewater system, and protect public health and the environment.

The Plan development involved multiple levels of stakeholder engagement, as illustrated on Figure 2.1. This section describes the stakeholder groups and committees shown in this figure as follows:

- Steering Committee and Focus Meetings - see Section 2.1
- The Advisory Group, Stakeholder Group, Strategic Planning Group, and Special Topic Groups (STGs) - see Section 2.2

The One Water LA 2040 Plan is more than just a planning document – it's the product of many people throughout the city working together to change the way water is managed. By bringing together all parties in the planning stage, a collaborative process was developed that will continue through the Plan's implementation and beyond.

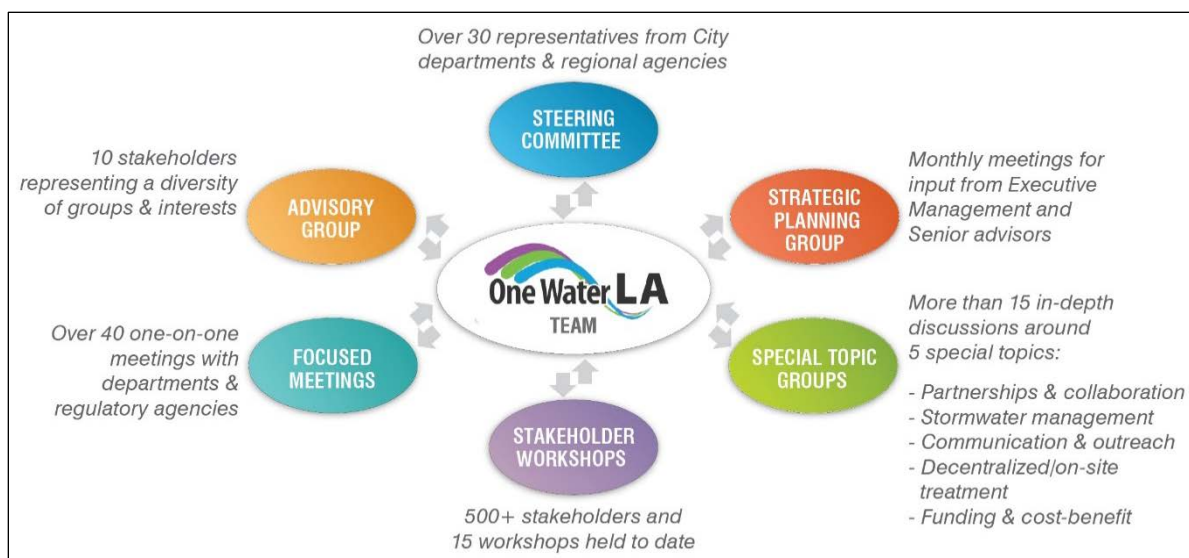

Figure 2.1 Multiple Levels of Stakeholder Engagement

2.1 INSTITUTIONAL FRAMEWORK

This section describes the institutional framework of the various participants that are engaged in One Water LA. The Plan was developed by dedicated representatives from both Los Angeles Sanitation (LASAN) and Los Angeles Department of Water and Power (LADWP), and shaped by input from other City departments and regional agencies. A detailed summary of roles and responsibilities can be found in Technical Memorandum (TM) 1.1 included in Volume 7.

2.1.1 City Organization

The City of Los Angeles is organized in 39 different departments that all report to the Mayor's office. As shown on Figure 2.2, there are 14 departments and bureaus currently involved in the Plan. These 14 City departments are part of the One Water Steering Committee, which was initiated during Phase 1 in February 2014.

LADWP and LASAN are the two leading City departments, working in partnership with other City departments and regional agencies. LASAN's core responsibility is the management and treatment of wastewater, stormwater, and solid waste, while the LADWP's core responsibility is the management and delivery of a high quality reliable potable and recycled water supply to its customers.

One of the unique elements of the Plan is cooperation and collaboration at many different levels within the City family. Integrating all departments involved in water management by opening channels of communication and building a framework for collaboration was vital to the successful development of the Plan. As listed on Figure 2.2, some of these departments and bureaus include multiple divisions that each represent different interests, objectives, and goals. In effect, the One Water LA Plan breaks these traditional silos and promotes a more holistic water management approach.

Together, LASAN and LADWP were responsible for:

- Preparing this Plan with input from the diverse groups shown on Figure 2.1.
- Initiating interactions with all other departments and regional agencies through Focus Meetings and the Steering Committee.
- Engaging stakeholders and the advisory group through meetings, workshops, and other activities.

LASAN and LADWP worked together to identify the key project, program, and policy recommendations of the Plan that will be presented to the Mayor's Water Cabinet.

2.1.2 Inter-Departmental Focus Meetings

Since the start of One Water LA, more than 40 inter-departmental/agency focus meetings were held. During these focus meetings, LASAN and/or LADWP staff met with individual City departments and/or regional agencies to discuss specific topics and potential water-related integration projects.

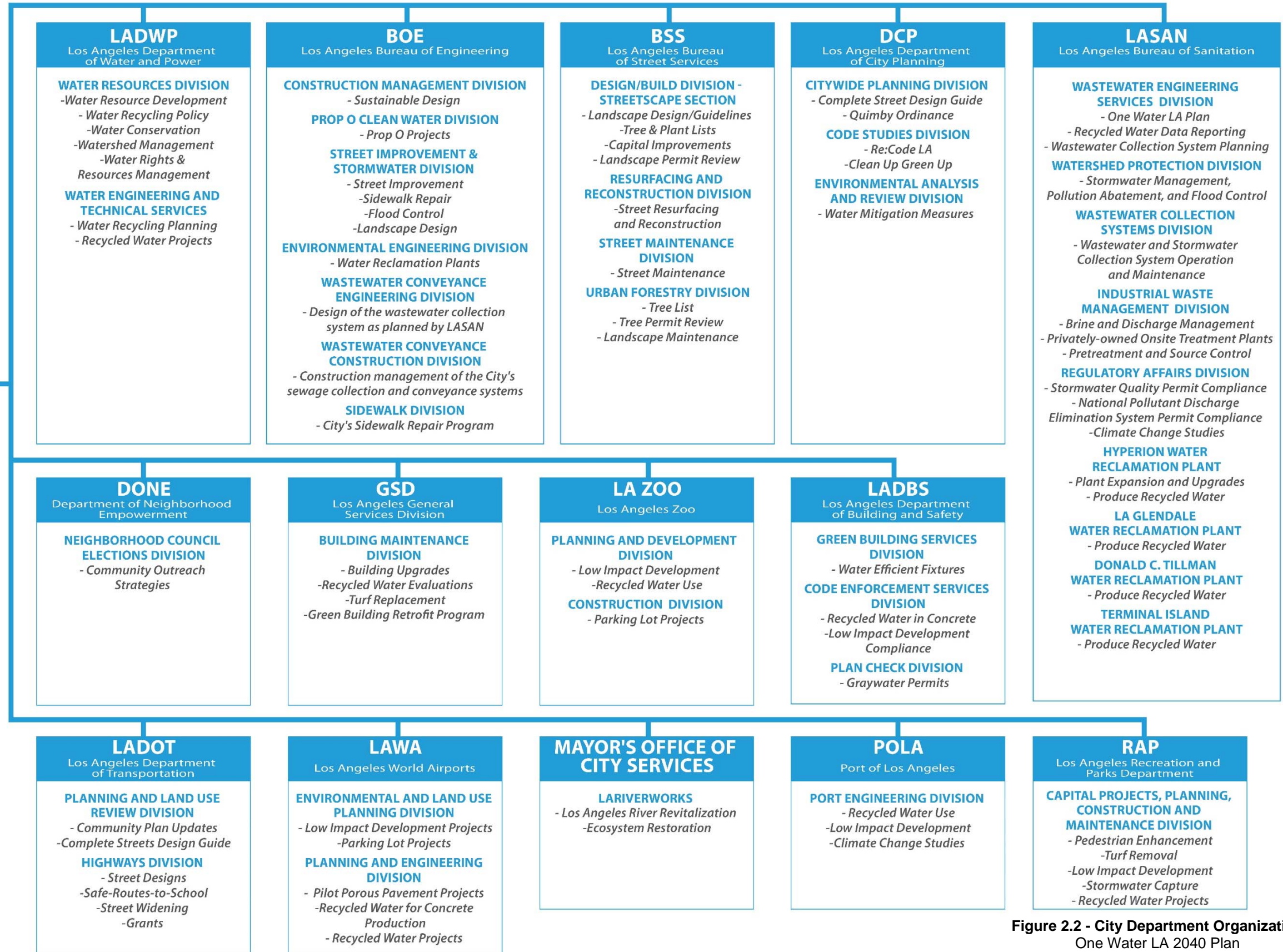

Figure 2.2 - City Department Organization
One Water LA 2040 Plan
Summary Report



2.1.3 Regional Agencies

There are currently ten regional agencies involved in One Water LA through participation in the Steering Committee (described in Section 2.1.4) or through collaboration at different stages in the Plan development. These agencies are shown in Table 2.1, which identifies their general area of interest and jurisdiction. It should be noted that some of the Plan recommendations will require involvement and collaboration with other outside agencies that are currently not engaged in the One Water LA Steering Committee meetings. Hence, the involvement of regional agencies will likely continue to evolve as the City begins implementation of the Plan.

Table 2.1 Regional Agencies Summary Report One Water LA 2040 Plan	
Agency	Jurisdiction/Interest
CALTRANS California Department of Transportation	LANDSCAPE ARCHITECT: DISTRICT 7 <ul style="list-style-type: none"> • Model Water Ordinance Standards • Recycled Water Use in Right-of-Way • Stormwater Capture Corridor Study
HSR High-Speed Rail Authority	SOUTHERN CALIFORNIA REGIONAL DIRECTOR/STAKEHOLDER OUTREACH DIVISION <ul style="list-style-type: none"> • Water Conservation Policy • Tree Planting Program • Recycled Water Projects • Stormwater Capture
LACDPW Los Angeles County Department of Public Works	WATER RESOURCES CORE SERVICE AREA <ul style="list-style-type: none"> • Stormwater Planning • Stormwater Compliance • Stormwater Engineering • Stormwater Maintenance • Watersheds
	DEVELOPMENT SERVICES & EMERGENCY MANAGEMENT CORE SERVICE AREA <ul style="list-style-type: none"> • Sewer Maintenance
	ENVIRONMENTAL SERVICES CORE SERVICE AREA <ul style="list-style-type: none"> • Environmental Programs • Strategic Planning & Sustainability
LACFCD Los Angeles County Flood Control District	<ul style="list-style-type: none"> • Stormwater Planning • Stormwater Engineering • Stormwater Maintenance
LACSD Sanitation Districts of Los Angeles County	ENGINEERING DIVISION <ul style="list-style-type: none"> • Sewer Design • Wastewater and Solid Waste Design
	TECHNICAL SERVICES DIVISION <ul style="list-style-type: none"> • Wastewater Research • Water Quality • Environmental Health and Safety
	WASTEWATER MANAGEMENT DIVISION <ul style="list-style-type: none"> • Joint Water Pollution Control Plant • Water Reclamation Plants • Wastewater Collection Systems

Table 2.1 Regional Agencies Summary Report One Water LA 2040 Plan	
Agency	Jurisdiction/Interest
LAUSD Los Angeles Unified School District	FACILITIES SERVICES DIVISION/MAINTENANCE & OPERATIONS <ul style="list-style-type: none"> • Modernization Program • Critical Repair Program • Drought Response Outreach Program for Schools • Stormwater Capture • Recycled Water Projects
	FACILITIES SERVICES DIVISION/ASSET MANAGEMENT <ul style="list-style-type: none"> • Leasing and Space Utilization • Planning and Design Management • Real Estate
METRO Los Angeles County Metropolitan Transportation Authority	ENVIRONMENTAL COMPLIANCE SERVICES DIVISION <ul style="list-style-type: none"> • Water Action Plan • Union Station Master Plan • Save the Drop Campaign • Dewatering Projects • Stormwater Capture • Recycled Water Projects
REGIONAL WATER UTILITIES	MWDSC <ul style="list-style-type: none"> • Metropolitan Water District of Southern California
	WBMWD <ul style="list-style-type: none"> • West Basin Municipal Water District
	WRD <ul style="list-style-type: none"> • Water Replenishment District
REGULATORY AGENCIES	EPA <ul style="list-style-type: none"> • Environmental Protection Agency
	LACDPH <ul style="list-style-type: none"> • Los Angeles County Department of Public Health
	LARWQCB <ul style="list-style-type: none"> • Los Angeles Regional Water Quality Control Board
	SWRCB <ul style="list-style-type: none"> • State Water Resources Control Board
USACE United States Army Corps of Engineers	SOUTH PACIFIC DIVISION: LA DISTRICT <ul style="list-style-type: none"> • Navigation • Flood Risk Management • Ecosystem Restoration • Disaster Response

2.1.4 Steering Committee

In 2014, the Steering Committee (Figure 2.3) was established to guide the development of the One Water LA Plan. Although this committee mostly consists of City departments, several regional agencies participate, including Los Angeles County Department of Public Works, LA County Flood Control District, Caltrans, High-Speed Rail, Los Angeles Unified School District, Metropolitan Water District of Southern California, Metropolitan Transportation Authority, and the Southern California Association of Governments. In total this group represents 14 City departments and 6 regional agencies.

The purpose of the Steering Committee has been to build needed inter-departmental and inter-agency relationships to formulate and implement One Water LA projects as well as the Plan, and to solicit input from Steering Committee members that are informed by their public outreach on related projects.

The Steering Committee collaborated to:

- Develop the Vision Statement, Objectives, and Guiding Principles with stakeholders.
- Identify water-related project integration opportunities.
- Develop policies to streamline and integrate water management and collaboration.



Figure 2.3 Steering Committee Members

Since the start of One Water LA, a total of nine Steering Committee meetings were held. This included four meetings in Phase 1 and five meetings in Phase 2. The key topics of each meeting are summarized in Table 2.2, while more detailed information on the participants, meeting dates, and outcomes is summarized in Volume 9.

Table 2.2 Summary of Steering Committee Meetings Summary Report One Water LA 2040 Plan		
Date	Meeting Number	Purpose/Objectives
2/26/2014	Steering Committee Meeting (Phase 1) #1	<ol style="list-style-type: none"> 1. Provided Overview of Scope and Schedule for One Water LA. 2. Obtained agreement on Vision and Critical Success factors.
4/15/2014	Steering Committee Meeting (Phase 1) #2	<ol style="list-style-type: none"> 1. Provided Overview of One Water LA. 2. Received feedback on draft Vision Statement and Objectives for the Plan. 3. Reviewed New Planning Baseline for One Water LA.
10/15/14	Steering Committee Meeting (Phase 1) #3	<ol style="list-style-type: none"> 1. Provided One Water LA Update. 2. Departments presented their respective water-related projects, programs, and policies.
1/8/2015	Steering Committee Meeting (Phase 1) #4	<ol style="list-style-type: none"> 1. Received feedback on the draft Guiding Principles for the Plan. 2. Provided Overview for Phase II Scope of Work. 3. Received updates from Steering Committee members on their respective projects and programs.
10/15/2015	Steering Committee Meeting (Phase 2) #1	<ol style="list-style-type: none"> 1. Provided One Water LA Updates. 2. Updates regarding progress on relevant projects/efforts were provided by City departments and regional agencies. 3. Discussed opportunities and challenges for near-term collaboration.
4/19/2016	Steering Committee Meeting (Phase 2) #2	<ol style="list-style-type: none"> 1. Highlighted upcoming work for Phase 2. 2. Held three breakout sessions, each categorized by water agencies, transportation agencies, and site managers to identify integration opportunities, opportunities for collaboration on funding, and joint marketing/promotion. 3. Discussed Branding and Cross Promotion within City departments and regional agencies.
7/28/2016	Steering Committee Meeting (Phase 2) #3	<ol style="list-style-type: none"> 1. Provided overview of Case Study development process and presented gathering and development of short-term integration opportunities (Case Studies). 2. Obtained input from Steering Committee members on Top 10 Case Studies and identified other opportunities for short-term integration. 3. Solicited input on Top 3-5 Case Study Projects. 4. Discussed Cross Promotion.
11/2/2016	Steering Committee Meeting (Phase 2) #4	<ol style="list-style-type: none"> 1. Presented near-term integration opportunities (Case Studies). 2. Obtained input from Steering Committee Meeting on long-term integration opportunities. 3. Brainstormed and gathered ideas on policies to promote inter-departmental/agency collaboration.
4/26/2017	Steering Committee Meeting (Phase 2) #5	<ol style="list-style-type: none"> 1. One Water LA Update presentation. 2. Obtained input from Steering Committee Meeting on the draft integrated policies and programs.

2.2 STAKEHOLDER ENGAGEMENT

During Phase 1 of One Water LA, productive stakeholder dialogue shaped the Vision, Objectives, and Guiding Principles. For Phase 2, a Public Engagement Plan was developed to establish stakeholder involvement programs, with the intent to continue the dialogue and input opportunities in planning tasks and studies, while also increasing and diversifying the stakeholder group. Importantly, Plan collaboration and stakeholder engagement revolved around achieving the following objectives:

- Connect the Plan implementation recommendations to the Vision, Objectives, and Guiding Principles, which reflect significant input from stakeholders.
- Continue to involve stakeholders in identifying ideas, asking questions, and providing feedback in the planning tasks, focusing input where there is greatest opportunity for shaping recommendations.
- Maximize the benefit of stakeholder input by aligning expertise and experience to focused subject matter discussions.
- Create partnerships and awareness to accelerate implementation of the Plan.
- Increase the diversity of stakeholders in order to obtain better representation of the diversity of ideas, interests, and perspectives in communities across Los Angeles.

The stakeholder engagement component of One Water LA is depicted on Figure 2.1. This included formation of an Advisory Group, a Stakeholder Group, a Strategic Planning Group, Special Topic Groups, as well Stakeholder Workshops. One Water LA also engaged stakeholders through:

- Presentations and updates at local conferences and forums in addition to meetings hosted by business interests, neighborhood councils, and other community organizations.
- One Water LA website and informational materials.

2.2.1 One Water LA Advisory Group

The One Water LA Advisory Group was formed to allow for more focused input from stakeholders in a smaller forum and on a more frequent basis. The Advisory Group played an instrumental role in formulating the basic building blocks for the Plan during Phase 1—the Vision, Objectives, and Guiding Principles. For Phase 2, the group's contributions were expanded to provide input to the planning efforts and on a variety of topics and issues that benefited from a diverse set of stakeholder perspectives, ensuring decision-making that is responsive to the needs of Los Angeles and its citizens. The Advisory Group meetings were professionally facilitated to ensure that the discussions are balanced and fair, information is provided in a transparent manner, and discussions stay focused and productive.

The Advisory Group consists of 10 representatives from neighborhood councils, non-profit organizations, business interests, healthcare, and academia in an effort to provide broad representation in terms of interests, geography within Los Angeles, and past participation in other water-related stakeholder processes. This group brings diverse perspectives and interests on integrated water management in Los Angeles. Advisory Group members included:

- Carolyn Casavan (Sherman Oaks Neighborhood Council)
- Brad Cox (Los Angeles Business Council)
- Jack Humphreville (Greater Wilshire Neighborhood Council)
- Louise McCarthy (Community Clinic Association of Los Angeles County)
- Ken Murray, MD (Wilderness Corps)
- David Nahai (David Nahai Companies)
- Mike O'Gara (Sun Valley Area Neighborhood Council)
- Veronica Padilla (Pacoima Beautiful)
- Kelly Sanders (University of Southern California)
- Melanie Winter (The River Project)

Since the start of One Water LA, a total of 13 Advisory Group meetings were held. This included four meetings in Phase 1 and nine meetings and two conference calls in Phase 2. The key topics of each meeting are summarized in Table 2.3, while more detailed information on the participants, meeting dates, and outcomes is summarized in Volume 9.

2.2.2 One Water LA Stakeholder Group

One Water LA included extensive stakeholder engagement, with the formation of the One Water LA Stakeholder Group. This group includes more than 500 stakeholders representing more than 200 organizations, including neighborhood councils, non-governmental organizations (NGOs), business and homeowner associations, academia, individuals, and others throughout the greater Los Angeles area. Approximately 250 stakeholders actively participate in workshops and meetings.

Since the start of One Water LA, a total of 14 Stakeholder Workshops and/or information meetings were held. This included 3 workshops/meetings in Phase 1 and 11 workshops/meetings in Phase 2. The key topics of each workshop/meeting are summarized in Table 2.4, while more detailed information on the meeting dates, key meeting topics, associated meeting materials, and outcomes are included in Volume 9.

Table 2.3 Summary of Advisory Group Meetings		
Summary Report One Water LA 2040 Plan		
Date	Meeting Number	Purpose/Objectives
10/9/2014	Stakeholder Advisory Group Meeting (Phase 1) #1	<ol style="list-style-type: none"> 1. One Water LA Desired Accomplishment. 2. Review Vision Statement and Objectives. 3. Review of Draft Agenda and Breakout Sessions for Workshop #2.
12/3/2014	Stakeholder Advisory Group Meeting (Phase 1) #2	<ol style="list-style-type: none"> 1. One Water LA Phases I and II Schedule. 2. One Water LA Vision and Objectives - Final. 3. One Water LA Workshop #2 Overview and Feedback. 4. Background and How to Develop Guiding Principles.
1/13/2015	Stakeholder Advisory Group Meeting (Phase 1) #3	<ol style="list-style-type: none"> 1. Review of Draft Guiding Principles. 2. Project Status
2/11/2015	Stakeholder Advisory Group Meeting (Phase 1) #4	<ol style="list-style-type: none"> 1. Discuss Revised Draft Guiding Principles. 2. Project Status
11/3/2015	Stakeholder Advisory Group Meeting (Phase 2) #1	<ol style="list-style-type: none"> 1. Provided a summary of Phase 1 and an overview of Phase 2. 2. Discussed role and mission of the Advisory Group. 3. Phase 2 stakeholder participation approach.
4/7/2016	Stakeholder Advisory Group Meeting (Phase 2) #2	<ol style="list-style-type: none"> 1. STG outcomes and Advisory Group input.
8/17/2016	Stakeholder Advisory Group Meeting (Phase 2) #3	<ol style="list-style-type: none"> 1. Get input on the Alternatives Analysis approach. 2. Discuss Evaluation Criteria. 3. Get input on outreach and communications priorities. 4. Share expected future meeting topics.
10/6/2016	Stakeholder Advisory Group Meeting (Phase 2) #4	<ol style="list-style-type: none"> 1. Alternative Analysis and Evaluation Criteria. 2. Projects and Project Concepts discussion. 3. Introduction to Cost Benefit Approach.
12/6/2016	Stakeholder Advisory Group Meeting (Phase 2) #5	<ol style="list-style-type: none"> 1. Debrief of Stakeholder Workshop #4 on 10/26/2016. 2. Debrief of Special Project Ideas Workshop on 11/18/2016. 3. Consensus on Final Evaluation Criteria.
2/19/2017	Stakeholder Advisory Group Conference Call	<ol style="list-style-type: none"> 1. Discuss One Water LA Progress Report document.
3/22/2017	Stakeholder Advisory Group Meeting (Phase 2) #6	<ol style="list-style-type: none"> 1. Draft One Water LA Progress Report Comments from Advisory Group.
5/23/2017	Stakeholder Advisory Group Meeting (Phase 2) #7	<ol style="list-style-type: none"> 1. One Water LA 2040 Plan Implementation Strategy.
6/12/2017	Stakeholder Advisory Group Conference Call	<ol style="list-style-type: none"> 1. One Water LA 2040 Plan Implementation Strategy.
10/23/2017	Stakeholder Advisory Group Meeting (Phase 2) #8	<ol style="list-style-type: none"> 1. Review and provide comments on One Water LA 2040 Plan Executive Summary
2/23/2018	Stakeholder Advisory Group Meeting (Phase 2) #9	<ol style="list-style-type: none"> 1. Review and provide input on Final Stakeholder Workshop on March 5, 2018.

Table 2.4 Summary of Stakeholder Group Workshops/Meetings Summary Report One Water LA 2040 Plan		
Date	Meeting Number	Purpose/Objectives
5/21/2014	Stakeholder Workshop (Phase 1) #1	<ol style="list-style-type: none"> 1. Introduction to One Water LA. 2. Water integrated resources plan updates. 3. One Water LA planning baseline.
11/6/2014	Stakeholder Workshop (Phase 1) #2	<ol style="list-style-type: none"> 1. Guiding Principles development (Breakout Sessions). 2. Breakout Session Topics: Water Supply Reliability, Watershed Health, Climate Change Mitigation and Adaptation, and Economic and Financial Stability.
3/5/2015	Stakeholder Workshop (Phase 1) #3	<ol style="list-style-type: none"> 1. Recap of One Water LA Phase 1 activities. 2. Department of City Planning and Port of Los Angeles Presentation. 3. Advisory Group comments. 4. Discussion of Draft Guiding Principles.
12/10/2015	Stakeholder Workshop (Phase 2) #1	<ol style="list-style-type: none"> 1. One Water LA Phase 2 overview. 2. Phase 2 Stakeholder Involvement Process. 3. Existing and Future Conditions Reports. 4. Special Topic Group sign-up.
6/29/2016	Stakeholder Workshop (Phase 2) #2	<ol style="list-style-type: none"> 1. Recycled Water Advisory Group (RWAG) Integration into One Water LA, GWR Environmental Impact Report. 2. One Water LA Phase 2 Update 3. Special Topic Group report out and Discussion (shared over two workshops).
9/13/2016	Stakeholder Workshop (Phase 2) #3	<ol style="list-style-type: none"> 1. Input on potential project approaches and evaluation criteria. 2. Updates on outcomes from Special Topic Groups. 3. Climate Change analysis approach with interactive quiz. 4. Preview of future workshop topics.
10/26/2016	Stakeholder Workshop (Phase 2) #4	<ol style="list-style-type: none"> 1. Alternatives Evaluation Process. 2. Present the Potential Projects. 3. Evaluation Criteria. 4. Input on Project Portfolio Themes. 5. Preview of future workshop topics.
11/18/2016	Projects Idea Workshop (Phase 2)	<ol style="list-style-type: none"> 1. Present List of Current Project/Program Ideas. 2. Review Project/Program Description Example. 3. Brainstorm of New Ideas.
12/13/2016	Stakeholder Workshop (Phase 2) #5	<ol style="list-style-type: none"> 1. Provide Overview of Policy Ideas Development Process. 2. Familiarization with current Policy Ideas List. 3. Review and Discuss Policy Ideas.
2/16/2017	Informational One Water LA Stakeholder Meeting	<ol style="list-style-type: none"> 1. Provide a better understanding of the overall plan and offer long-time participants a chance to be updated on progress for all of the tasks and to ask questions.
5/11/2017	Informational One Water LA Stakeholder Meeting	<ol style="list-style-type: none"> 1. Wastewater Facilities Plan Presentation and Dialogue. 2. Stormwater Facilities Plan Presentation and Dialogue.
6/19/2017	Stakeholder Workshop (Phase 2) #6	<ol style="list-style-type: none"> 1. One Water LA implementation strategy and triggers.
10/16/2017	Los Angeles River Informational Meeting	<ol style="list-style-type: none"> 1. Information sharing on various Los Angeles River Studies
3/5/2018	Stakeholder Workshop (Phase 2) #7	<ol style="list-style-type: none"> 1. Presentation of Final Draft Plan. 2. Discussion of stakeholder engagement opportunities during Plan implementation.

2.2.2.1 Progress Report

An interim progress report was developed to communicate and share with stakeholders the City's One Water LA accomplishments and progress to date as of July 2017. The information presented in the Progress Report represented a snapshot in time and this Summary Report further refines the goals and strategies discussed in the Progress Report. The One Water LA Progress Report can be found in Volume 9.

2.2.3 Special Topic Groups

To provide an opportunity for in-depth and focused stakeholder engagement, five Special Topic Groups (STGs) were created for key Plan components. The purpose of these groups was to obtain the benefits of outside perspectives during the planning process. The topics identified for these STG discussions include:

- Stormwater and Runoff Management.
- Funding and Cost-Benefit Analysis.
- Outreach and Communication.
- Partnership, Collaboration, and Innovation.
- Decentralized Use and On-Site Treatment.

Stakeholders were invited to sign-up for one or more STGs at the first Stakeholder Workshop of One Water LA during Phase 2. A number of stakeholders representing a wide range of perspectives and backgrounds participated in this process, as shown in Table 2.5. Each STG had three meetings, with the exception of the Funding and Cost-Benefit STG, which met four times. Hence a total of 16 meetings were conducted between January 2016 and October 2016.

Each group discussion was led by a City representative, who was supported by a technical lead from the Consultant Team. In addition, each group had a dedicated facilitator and scribes to record all input provided during the discussions. The key meeting topics discussed in each STG is summarized in Table 2.5, while more detailed information on the meeting dates, associated meeting materials, and outcomes are included in Volume 9.

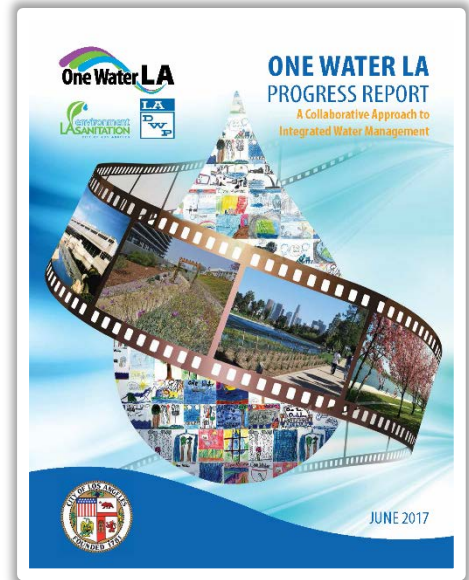

Table 2.5 Summary of Special Topic Groups Meetings Summary Report One Water LA 2040 Plan				
Special Topic Group	No. of Stakeholders	Meeting No.	Meeting Date	Topics/Discussion Items
Stormwater and Runoff Management	21	1	3/24/2016	Share information and resources. Ideas on opportunities, priorities, and solutions.
		2	4/30/2016	Refine and prioritize stormwater policy and program recommendations.
		3	6/23/2016	Draft presentation for stakeholder workshop - STG report.
Funding and Cost-Benefit Analysis	13	1	3/29/2016	Share information and resources, and begin to discuss opportunities, priorities, and solutions.
		2	4/29/2016	Continue discussion of opportunities and solutions, and identify action steps.
		3	6/3/2016	1. Funding Survey Results. 2. Benefit-Based-Cost Breakout Session.
		4	8/18/2016	Review draft summary of outcomes and fine-tune in preparation for presentation at the stakeholders workshop.
Outreach and Communication	7	1	3/18/2016	Share information and resources, begin to discuss opportunities, priorities and solution, and determine STG deliverables.
		2	5/3/2016	Continue discussion of opportunities and solutions, and identify action steps.
		3	6/15/2016	Review draft summary of outcomes and fine-tune in preparation for presentation at the stakeholders workshop.
Partnership, Collaboration, and Innovation	15	1	3/16/2016	Share information and resources, and begin to discuss opportunities, priorities, and solutions.
		2	5/5/2016	Continue discussion of opportunities and solutions, and identify action steps.
		3	6/16/2016	Review draft summary of outcomes and fine-tune in preparation for presentation at the stakeholders workshop.
Decentralized Use and On-Site Treatment	12	1	3/24/2016	On-Site-Treatment Facilities - gain input for content of future policies.
		2	5/9/2016	Graywater - gain input for content of future policies.
		2	6/14/2016	Review draft summary of outcomes and fine-tune in preparation for presentation at the stakeholders workshop.

2.2.4 Strategic Planning Group

The Strategic Planning Group consists of members of the Executive Management staff from both LASAN and LADWP, as well as a representative from the Mayor’s office and a select group of outside technical advisors. The purpose of this group was to obtain direction from and report progress to LASAN and LADWP executive and senior leadership on a consistent basis. During Phase 2, the Strategic Planning Group met on a monthly basis to provide guidance to the Plan development and help make decisions at critical junctures. Updating executive management on a regular basis promoted smooth integration with other relevant ongoing projects, engendered collaboration, and achieved consensus on the overall Plan recommendations.

2.3 ACCOMPLISHMENTS TO DATE

This section serves to share some of the accomplishments One Water LA achieved through ongoing collaboration during the Plan’s development. The accomplishments have been organized to show progress on each of One Water LA’s seven objectives:

1. INTEGRATE MANAGEMENT OF WATER RESOURCES AND POLICIES

- Established One Water LA Steering Committee, Stakeholder Group and Advisory Group to help shape the plan and facilitate collaboration.
- Collaborated with stakeholders to identify policy and program recommendations.
- Developed current integrated project opportunities to serve as role models for future collaboration.
- Showcased linkage between three LA River Studies by One Water LA, University of California Los Angeles (UCLA) and The Nature Conservancy’s (TNC) that provided valuable information to help guide water management alternatives for optimization of flow needs for the LA River.
- Developed a Water Balance Tool that provides estimated flows for potable water, wastewater, recycled water, stormwater, river flows, ocean discharges, and estimated capital and unit costs for various combinations of projects and hydrologic conditions.
- Encouraged by the One Water LA Team, the Port of LA has elevated the importance stormwater capture in their designs. An innovative stormwater design has already been incorporated at one of their major container yards.

2. BALANCE ENVIRONMENTAL, ECONOMIC, AND SOCIETAL GOALS

- Developed 18 project evaluation criteria based on environmental, economic, and societal goals. Invited stakeholders to participate in an exercise to weigh the relative importance of each of the project evaluation criteria.
- Identified funding strategies and cost-sharing opportunities with a knowledgeable and diverse group of stakeholders, including LA County and private companies, to help leverage existing dollars and maximize public investments.
- Developed Stormwater and Urban Runoff Facilities Plan (SWFP) to guide the City and its partners in meeting the City’s goals of increasing stormwater capture, improving water quality, providing flood protection, and building more sustainable and resilient green infrastructure.

- Provided guidance that resulted in a streamlined permitting process and decreased fees for Stormwater management projects in the public right of way.
- Provided input on stormwater measures for the Department of City Planning's Clean Up Green Up ordinance. This initiative aims to address environmental justice issues in communities disproportionately affected by industrial land uses and polluting sources.

3. IMPROVE HEALTH OF LOCAL WATERSHEDS

- The SWFP identifies over 1,200 project opportunities required to help meet the City's goals while providing improved flood protection, water quality benefits, and/or water supply enhancements.
- Strategies were integrated in the stormwater facilities plan from the following reports: LASAN's Enhanced Watershed Management Program (EWMP) Plans, LADWP's Stormwater Capture Master Plan, City of LA Stormwater and Green Infrastructure 5-year CIP, Green Streets Program, LA River Ecosystem Restoration Integrated Feasibility Report, and the County's LA Basin Stormwater Conservation Study.
- Developed a project concept with LAUSD management and staff to capture, treat, and infiltrate off-site stormwater at a school site.
- Developed policy and program recommendations designed to remove barriers and increase implementation of parcel-based and other distributed, nature-based solutions.
- Analyzed dry- and wet-weather flow diversion opportunities to improve waterway quality and increase recycled water availability.

4. IMPROVE LOCAL WATER SUPPLY RELIABILITY

- Updated City of LA's engineering specifications to allow for recycled water use in concrete mixes. Using recycled water decreases potable water demand.
- Identified operations and maintenance alternatives with other City Departments and Regional Agencies to help minimize water consumption.
- Identified potential stormwater and water reclamation plant projects to increase water recycling.
- Identified options to help maximize and optimize potable reuse from the City's Water Reclamation Plants (WRPs).

5. IMPLEMENT, MONITOR, AND MAINTAIN A RELIABLE WASTEWATER SYSTEM

- Prepared a wastewater facilities plan for the City's four Water Reclamation Plants.
- Identified techniques to model and monitor collection system capacity.
- Identified policies and guiding principles with stakeholders for onsite treatment facilities (OSTF) to consider during review of proposed OSTFs.
- Analyzed opportunities for new satellite water reclamation plants to create a distributed system of recycled water production.
- Identified climate resilient strategies to incorporate into design processes for new and existing projects including pumping plants, low flow diversions, stormwater treatment facilities, and water reclamation plants.

6. INCREASE CLIMATE RESILIENCE

- Identified flood, liquefaction, landslide, fire, and tsunami impact zones. Conducted field evaluations of critical and vulnerable wastewater infrastructure facilities.
- Identified and prioritized projects for wastewater and stormwater infrastructure facilities to address climate change associated threats.
- Developed approaches for the City to update design manuals and specifications to be climate resilient for all capital projects. The team is currently sharing the approach and necessary data with City Departments and Regional Agencies.
- Developed a climate-change resilient tree list with local nurseries and Bureau of Street Services. Included ability to withstand increased number of hot days and drought conditions.
- Worked with the Department of City Planning to provide recommendations on how to address climate impacts on infrastructure to the Governor's office of Planning and Research.

7. INCREASE COMMUNITY AWARENESS AND ADVOCACY FOR SUSTAINABLE WATER

- Conducted numerous workshops and informational meetings to involve stakeholders in the Plan's development.
- Identified cross-educational and training opportunities with other City Departments to help increase awareness and education for all water issues.
- Conducted a tour of Ed P. Reyes River Greenway for Dept. of City Planning staff to demonstrate Stormwater improvement projects within the City.
- Partnered with schools and universities to expand water-related education:
 - *Young Citizens Artist Project - semester-long project that challenges students in creating new ideas and solutions to capture, conserve, and reuse water at their community. The project is in its third year.*
 - *One Water LA Curriculum - developed a curriculum with LAUSD and Metropolitan Water District to reduce water use at schools and homes, and to educate and empower students on water conservation.*
 - *GALA STEM - introduced students to STEM careers in the design and engineering of public infrastructure by doing hands on activities with practitioners.*
 - *Pepperdine University – incorporated the student's recommendations into the One Water LA communications plan.*
 - *USC, UCLA, and CSUN – increased coordination and partnerships with local universities on various topics, including: research studies, LA River, onsite treatment facilities, policies, programs, and more.*
- Increased the number and diversity of stakeholders to involve a wide range of groups, and interests including environmental, health, business, and more.
- Maximized the benefit of stakeholder input by aligning expertise and experience to focused subject discussions.
- Co-sponsored a series of five Community Dialogues focused on green infrastructure and the importance of multi-benefit projects. The Community Dialogues, led by the Council for Watershed Health and local partners, were designed to engage a broader audience of community-based stakeholders beyond traditional non-profits and agency participants.

2.4 ONGOING COLLABORATION AND ENGAGEMENT ACTIVITIES

This section provides a brief overview of ongoing collaboration and engagement activities.

2.4.1 Community Engagement

One Water LA engagement and education efforts have been designed to maximize awareness and understanding of the One Water LA Plan and the importance of improving the health of our watersheds and increasing our local water supply through stormwater capture and expanded use of recycled water for both non-potable and potable uses. The One Water LA Team has made numerous presentations to interest groups including Neighborhood Councils, non-profit organizations, business and industry groups, and trade associations. The Team has also hosted informational booths at many area fairs, festivals, and trade events. A full list of community engagement efforts can be found in Volume 9 in Other Engagement Activities.

2.4.2 Continued Inter-Departmental and Agency Collaboration

The Steering Committee will continue as the framework and forum for inter-departmental collaboration during the implementation of this Plan. Smaller focus groups will be developed to support specific aspects and topics of the implementation process. Implementation of projects, programs, and policies will further strengthen collaboration and leadership from multiple departments and increase partnerships with regional agencies. The Mayor's Water Cabinet will continue to review and oversee ideas and new policies from different departments, academia, and technical experts.

Some examples of inter-departmental and agency collaboration includes, but is not limited to, the following:

- Department of City Planning
 - **Re:Code LA** is preparing a new zoning code for the first time since 1946 that will enable the City to apply more tailored zoning that responds to the needs of the community. The One Water LA team has been taking advantage of this unique opportunity by guiding the City's Planning Department on water-related code updates. The new code will be available for the upcoming Community Plans to use in their update efforts and to help implement the vision of the General Plan.
 - **OurLA2040** is an update of the City's General Plan, and the One Water LA team has been working with the Department of City Planning to help draft the water element. The General Plan is the heart and foundation of the City's long-range planning endeavors and serves as the basis for physical, economic, social, cultural, and environmental decision-making.
- Los Angeles Unified School District
 - As described in more detail in Chapter 5 (Current Integration Opportunities), One Water LA is working with LAUSD to identify a school site to demonstrate the benefits of an off-site **Stormwater Capture Infiltration Pilot project**, which can consist of a pre-treatment system, concrete tank, monitoring system, valves, and potential irrigation system.

- Los Angeles Zoo
 - **The new LA Zoo Master Plan** incorporated opportunities to capture and use stormwater as well as utilize recycled water for washdown, irrigation, animal exhibits and more. As described in more detail in Chapter 5 (Current Integration Opportunities), One Water LA has collaborated on the development of the LA Zoo Master Plan. One Water LA will continue to collaborate with the zoo during design, and construction to help implement water management strategies and water educational elements into the zoo.
- Department of Public Works
 - **Review of Design Criteria, Specifications, and Design Manuals** to determine infrastructure performance for climate resiliency. This will also include streamlining permit reviews, approvals, and costs.

2.4.3 Future Engagement Activities

The immediate and near-term steps that the City plans to undertake to implement the findings and recommendations presented in this Plan are:

1. Preparation of a Programmatic Environmental Impact Report (PEIR)
2. Continued Inter-Departmental Collaboration and Coordination through the following committees:
 - a. Implementation Strategy Committees
 - b. Inter-Departmental Committee
 - c. Inter-Agency Coordination Committee(s)
3. Continued Stakeholder Engagement and Public Outreach
4. Future One Water LA Plan Updates & Reporting
5. Implementation of specific projects and programs that are recommended in the Plan.

These activities are critical to make the One Water LA Plan a success and help guide the City with future decision making when prioritizing and implementing water, wastewater, and stormwater infrastructure improvements. Chapter 10 of the Summary Report includes additional details on the future engagement activities.

-This Page Left Blank Intentionally-

EXISTING WATER MANAGEMENT STRATEGIES

Chapter 3 summarizes existing water management challenges and the existing water supplies. The City's existing water supplies and water supply goals are summarized first, followed by more detailed descriptions of the City's current local water supplies, such as water conservation programs, local groundwater supplies, recycled water, and stormwater. The information presented herein presents and builds upon important elements of the LADWP's 2015 Urban Water Management Plan (UWMP). The estimated flows and demands for each of these water sources are discussed in Chapter 4.

3.1 EXISTING WATER MANAGEMENT CHALLENGES

The One Water LA 2040 Plan (Plan) looked at a wide variety of water-related issues and challenges that require new integrated water management strategies in the future to address:

- **Meeting Stormwater Quality Regulations** – To protect beaches and marine life, regulators establish total maximum daily loads (TMDL) for various pollutants found in runoff. These TMDLs are regulated through the new Los Angeles County Municipal Separate Storm Sewer System (MS4) permit that took effect in 2012, as described in Chapter 1. The City has a certain amount of time to comply with these TMDL requirements to avoid fines. These compliance deadlines are approaching rapidly, yet there is no funding mechanism in place to pay for the improvements to meet the MS4 permit limits.
- **Adapting to Changing Flood Protection Needs** – More frequent intense storm events could result in flooding. Increased stormwater capture and recharge is a key strategy to achieve flood protection and water quality goals. The City needs to adopt preventive mitigation and adaptation measures to minimize flooding during these storm events.
- **Replacing Aging Infrastructure** – The City owns thousands of miles of water, sewer, and stormwater pipelines, along with associated facilities. The vast majority of these systems are old and approaching the end of their useful life. Replacing all aging infrastructure in the City at once is not feasible, so the challenge is to prioritize replacements and repairs of the assets. Ancillary challenges of this tremendous undertaking include limited condition assessment data, along with limited funds and resources to repair and replace aging infrastructure.
- **Preparing for More Frequent and Prolonged Drought Conditions** – The City's current supply mix is heavily dependent on imported water from Northern California, the Eastern Sierra, and the Colorado River Watershed. Chronic and more severe droughts reduce the reliability of imported water supplies. The recent drought reduced the State Water Project (SWP) initial delivery allocation to zero percent in 2014 for the first time in history ending the year at only five percent, while Colorado River Aqueduct (CRA) deliveries are also vulnerable due to the 15+ year drought in the Colorado River watershed. The resultant reduction in imported water supplies has both reduced imported water supply reliability and increased stresses on many groundwater aquifers. The City must adapt and execute its plan for more frequent and prolonged drought conditions as described in the UWMP.

- **Preparing for Greater Demands** – Los Angeles continues to grow and it is estimated that it will add approximately 500,000 residents by year 2040, increasing the total population to roughly 4.5 million. As the City grows, demands on water-related resources will continue to increase. To accommodate this increasing demand, the City must continue to plan for the necessary facilities to accommodate water supply, wastewater, recycled water, and stormwater system needs in addition to the maintenance requirements of existing facilities.
- **Becoming Climate Resilient** – The City must prepare for an increasingly unpredictable climate to become a more climate-resilient city. This means not only preparing for droughts, but also increasing temperatures, more intense precipitation events and associated flooding risks, sea level rise, risk of wildfires, and damage from high winds.
- **Limited Funding** – The City has limited funds and resources to address all of its water management challenges and is faced with a lack of resources to properly address operations and maintenance (O&M) needs of some facilities. Integrated planning between City departments would help prioritize needs, develop multi-benefit solutions, and identify funding sources and cost-sharing opportunities.

3.2 EXISTING WATER SUPPLIES

The City uses numerous water supply sources, programs, and practices to meet water demands, drinking water quality standards, wastewater discharge limits, and environmental water quality requirements. As described in LADWP's UWMP, the City's primary water supply sources are groundwater, imported water, and recycled water. Water conservation is seen as both a demand control measure and/or a source of supply. Of the local supplies being pursued, additional planned conservation is the biggest contributor toward reducing imported water purchases and increasing local supply reliability through 2040, and is therefore considered a crucial supply asset. In addition, the City has started with the implementation of stormwater capture projects to provide additional water supply benefits.

3.2.1 Existing Water Supply Mix

LADWP's UWMP identifies three different aqueducts that bring water to the City from the Eastern Sierra region, the Colorado River region, and the Sacramento-San Joaquin Delta in Northern California, as shown on Figure 3.1. These three aqueducts are characterized as follows:

1. **Los Angeles Aqueduct (LAA)** – This aqueduct conveys water from the Eastern Sierras and is owned and operated by LADWP. Water is conveyed the entire distance by gravity alone, with a total length of 338 miles extending from Mono Basin to Los Angeles. The LAA consists of the First LAA completed in 1913, and the Second LAA completed in 1970. The second aqueduct increased the City's capacity to deliver water from the Eastern Sierras from 485 cubic feet per second (cfs) to 775 cfs. LADWP regulates deliveries to the Los Angeles Aqueduct Filtration Plant (LAAFP) through storage control at nine reservoirs. Six reservoirs are used for storage: Grant Lake, Long Valley, Tinemaha, North Haiwee, South Haiwee, and Bouquet Reservoir. The remaining three reservoirs are used to regulate flow for hydroelectric power plant generation, which include Pleasant Valley, Fairmont, and Drinkwater. The total combined reservoir storage capacity of the system is 300,246 acre-feet (AF). Hydroelectric power is generated at 12 power plants along the LAA.

2. **Colorado River Aqueduct (CRA)** – This aqueduct delivers water from the Colorado River Watershed and is owned and operated by MWDSC. The CRA is 242 miles in length. Corresponding MWDSC facilities include pumping plants, pipelines, treatment plants, reservoirs, and hydroelectric recovery power plants.
3. **State Water Project's (SWP) California Aqueduct** – This aqueduct delivers water from the Northern California Sacramento-San Joaquin Delta region and is owned and operated by the California Department of Water Resources (DWR). The SWP system consists of 662 miles of aqueduct, 32 storage facilities (reservoirs and lakes), and 25 power and pumping plants. MWDSC became a contractor for SWP water in 1960 and is the largest of 29 SWP contractors. MWDSC deliveries to Southern California were first received in 1972.



Figure 3.1 Existing Sources of Water Supply

The UWMP also identifies four principal water supply sources used to meet the City's water demands: imported water, groundwater, recycled water, and water conservation. The historical water supply mix of these four sources varies greatly annually and is largely influenced by hydrological conditions and environmental water needs. The average water supply mix distribution from Fiscal Year 2011-2016 is presented on Figure 3.2. As shown, the City has imported approximately 84 percent of its entire water supply from hundreds of miles away, of which 20 percent was imported via the LAA, while the remaining 64 percent consists of imported water purchases from the SWP's California Aqueduct and CRA. The remaining 14 percent of the City's water supply comes primarily from local groundwater (12 percent) and recycled water (2 percent). It should be noted that stormwater contributes indirectly to the City's water supply through infiltration in the City's underlying groundwater basins.

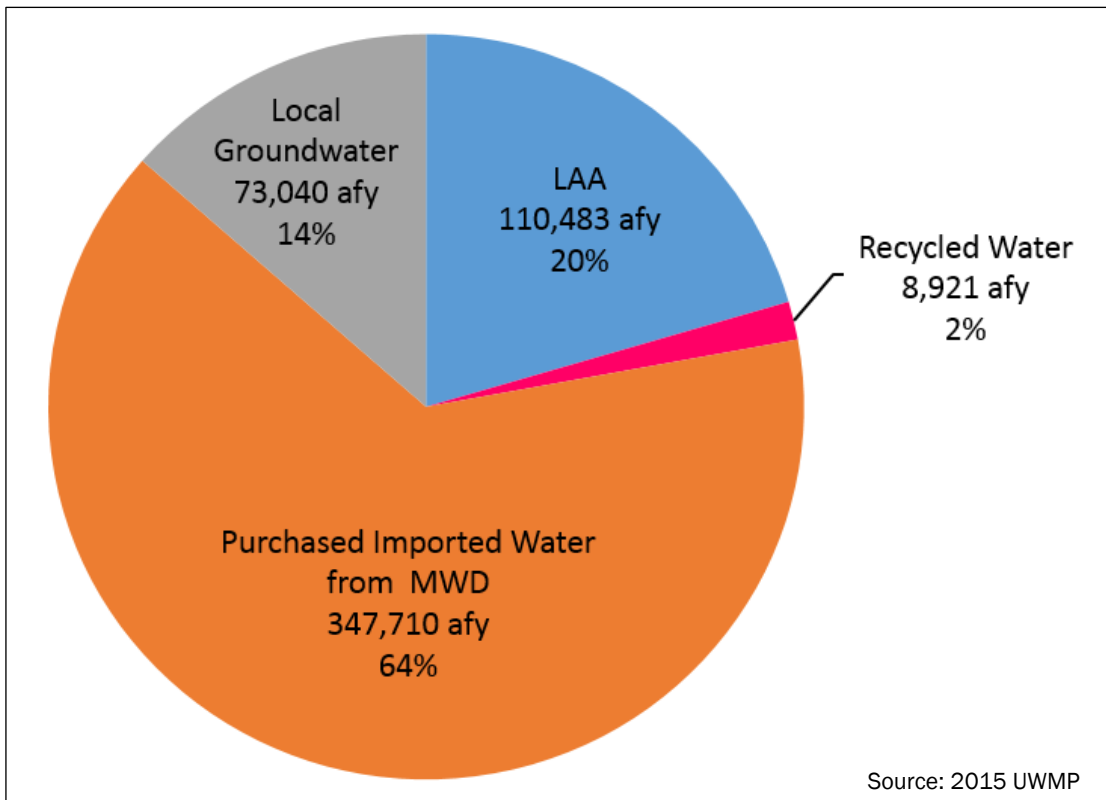

Figure 3.2 5-Year Historical Supply Mix Average (2011-2016)

The City's annual supply mix varies greatly depending on hydrologic conditions as water demands tend to increase during dry years, while snowpack and imported water supply availability decrease during dry years. However, the opposite is true during wet years. Therefore, the distribution of the City's supply sources can greatly vary from year to year, as illustrated on Figure 3.3.

The City's current water supply mix results in a heavy dependence on snowfall and sufficient storage in Northern California, the Eastern Sierra Mountains, and the Colorado River watershed. In recent years, drought conditions and climate change severely impacted the amount of snowfall in the Eastern Sierra and the Colorado River watershed. As these water supplies fluctuate, so does the City's ability to import water from these sources.

Moreover, all three aqueducts cross the San Andreas Fault and are subject to prolonged interruptions in case of a major seismic event. The Plan recognizes that local supply sources are more reliable and a top priority of the City.

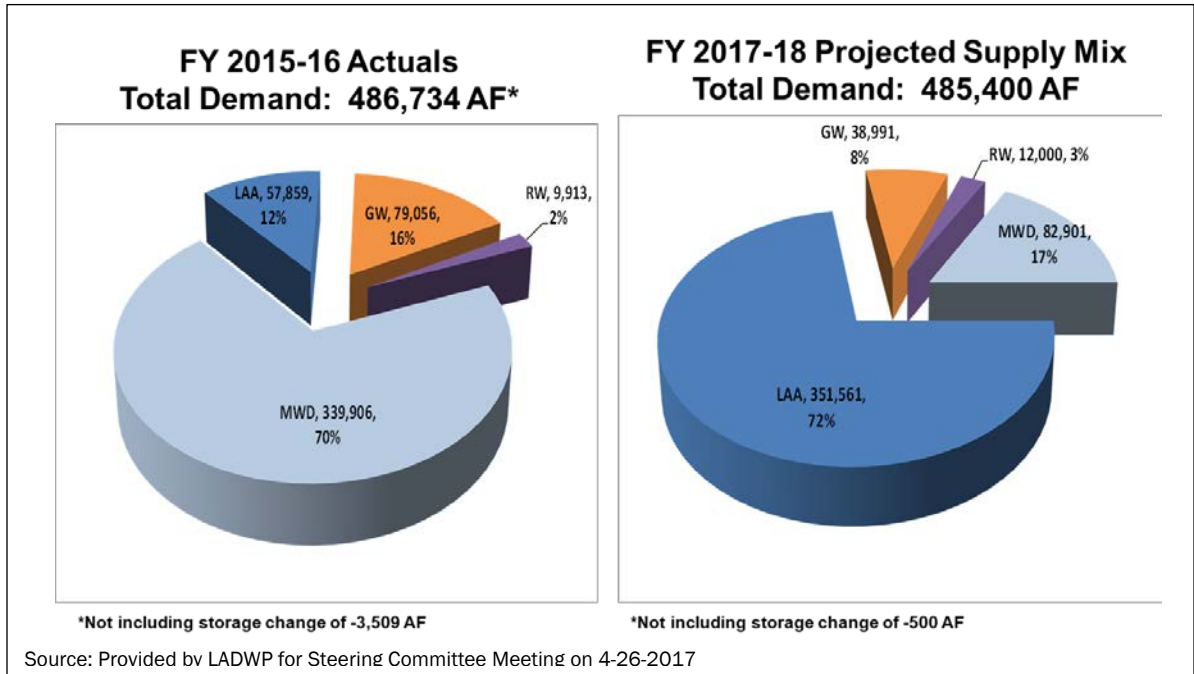

Figure 3.3 Supply Mix in FY 2015/16 (dry) and Projected for FY 2017/18 (wet)

3.2.2 Reducing Reliance on Imported Water

LADWP's 2015 UWMP evaluated groundwater, recycled water, stormwater, and water conservation. The Plan supports the UWMP by identifying a collaborative approach for integrated water management to help achieve these goals through further development of potential collaborative water management strategies that enhance local water supply such as increasing local groundwater recharge, maximizing water recycling, and taking a three-legged stormwater management approach that integrated water supply, flood risk mitigation, and water quality benefits.

Water Conservation – Conservation has had a tremendous impact on Los Angeles' water use patterns and has become a permanent part of LADWP's water management philosophy as outlined in its 2015 UWMP. The City of Los Angeles has long recognized water conservation as the core of multiple strategies to improve overall water supply reliability. Through its investments in conservation, Los Angeles has become a national leader in water-use efficiency. In the future, conservation is expected to be the biggest contributor toward reducing imported water purchases and increasing local supply reliability. By 2040, water conservation is projected to expand with an additional 110,100 acre-feet per year (AFY) in average years or 143,900 AFY in dry years. These do not include the 118,000 AFY of cumulative hardware savings achieved by 2015 since the late 1980s.

Local Groundwater – Local groundwater provides an important resource to supplement imported water supplies. Also, groundwater is very important during an emergency, such as an earthquake when aqueducts could be damaged. The groundwater aquifers function as belowground "water banks" that are replenished with stormwater and imported water used for irrigation and spreading. However, decades of urbanization have greatly increased impervious hardscape, while stormwater runoff has been channelized and diverted away from local aquifers. To enhance groundwater supplies, the City and County of Los Angeles utilize groundwater spreading grounds and associated recharge basins combined with small-scale infiltration mechanisms to capture and recharge stormwater into local aquifers where water can be stored. These water banks can be relied upon for use during drier periods when surface water is scarce. In addition, industrial contamination issues have greatly impaired local groundwater pumping. In the San Fernando Basin (SFB), more than 80 of LADWP's 115 water supply wells have been removed from service or restricted in use. In response to these issues, the City has renewed its focus on protecting and rehabilitating its local groundwater basins, including expanding the remediation efforts for the SFB as a key strategy in the LADWP's 2015 UWMP. Remediating the SFB is expected to remove contamination and restore the beneficial use of the basin, including the recovery of full groundwater rights and supporting groundwater recharge with recycled water and stormwater.

Recycled Water – The City has a long history of utilizing recycled water for non-potable purposes to offset the use of potable water supplies. To further increase the use of recycled water, the City is exploring the expansion of non-potable reuse (NPR), as well as potable reuse with groundwater augmentation, raw water augmentation, and treated water augmentation strategies. Expansion of recycled water use to offset potable demands has been included as one method that would help achieve the pLAN goals to reduce imported water purchases. In addition, the City is pursuing a groundwater replenishment (GWR) project to replenish the San Fernando Groundwater Basin with highly treated recycled water from the Donald C. Tillman Water Reclamation Plant (DCTWRP). Project completion is expected in 2024. According to the 2015 UWMP, recycled water use is projected to increase seven-fold from the current 10,000 AFY to 75,400 AFY by 2040, including 45,400 AFY of municipal/industrial non-potable reuse and 30,000 AFY of indirect potable reuse from the GWR Project. The Plan evaluates opportunities to maximize water recycling production for each of LASAN's four water reclamation plants, as well as the implementation of new satellite water reclamation plants.

Stormwater – The 2006 Water IRP brought a new perspective to stormwater as an important resource, which resulted in the approval of Prop O and completion of approximately \$500 million worth of stormwater projects. Stormwater runoff from urban areas is an underutilized local water resource. Within the City of Los Angeles, the majority of stormwater runoff is directed to storm drains and ultimately channeled into the ocean. This unused stormwater reaching the ocean carries with it many pollutants that are harmful to marine life and public health. In addition, local groundwater aquifers that should be replenished by stormwater are receiving less recharge than in the past due to increased urbanization. In response, LADWP completed a Stormwater Capture Master Plan (SCMP) in 2015 to comprehensively evaluate stormwater capture potential within the City. The City is evaluating stormwater, taking into consideration flood protection, water supply benefits, and water quality compliance requirements as laid out in the City's various Water Management Plans. Opportunities are being identified to increase the utilization of stormwater as a local supply source, to manage flooding,

and to enhance downstream water quality. Stormwater capture can be achieved by increasing infiltration into groundwater basins (i.e., groundwater recharge) and by on-site capture and reuse of stormwater for landscape irrigation (i.e., direct use). Capturing, using and infiltrating more stormwater is a natural way to replenish local groundwater aquifers while improving water quality in our ocean, rivers, and other water bodies. Stormwater capture is projected to increase two- to three-fold by 2035, from 64,000 AFY to 132,000 AFY in the SCMP's conservative case, or 178,000 AFY in the SCMP's aggressive case.

3.2.3 Local Supply Development Goals

The recent multi-year drought resulted in diminished supplies from the LAA and heavy reliance on purchased imported water from MWDSC. When Governor Brown declared the drought emergency in January 2014, Angelinos responded quickly and reduced water use by 22 percent. Subsequently, in October 2014, Mayor Eric Garcetti issued Executive Directive No. 5 (ED#5), which set goals to not only reduce per-capita water use, but also to reduce purchase of imported water supplies. Released in April 2015, the Sustainable City Plan (pLAn) incorporates targets established in ED#5 to set short-term and long-term goals. Although, 2016-2017 was a wetter year, it does not diminish these goals. The long-term strategies laid out in the LADWP 2015 UWMP are aligned to meet the pLAn goals, which target reduced water use, reduced reliance on imported water, and increased local supply development as follows:

- Reduce per-capita water use 20 percent by 2017, 22.5 percent by 2025, and 25 percent by 2035
- Reduce the purchase of imported water by 50 percent by 2025
- Source 50 percent of water locally by 2035
- Capture 150,000 AFY of stormwater by 2035

The 2015 UWMP provides a strategy of how to meet the local water supply goals under normal and dry year conditions. The Plan includes a comprehensive strategy to meet the stormwater capture goals with a combination of centralized and distributed stormwater projects that collectively are estimated to achieve the pLAn goals.

3.3 WATER CONSERVATION

The City has been long-recognized as an early pioneer of water conservation programs, continues to be a national leader in water use efficiency, and has one of the lowest per-capita water uses among large cities in the United States. Since the 1970s, water conservation has been a permanent part of the City's water supply planning. By 2015, the City has a cumulative hardware conservation savings of 118,000 AF annually since the inception of conservation savings tracking in the late 1980s. This accomplishment is also referred to as historical conservation. Due to decades of water conservation efforts, the City's water demand has been relatively flat for the last 40 years, despite an increase of over one million residents, as shown on Figure 3.4.

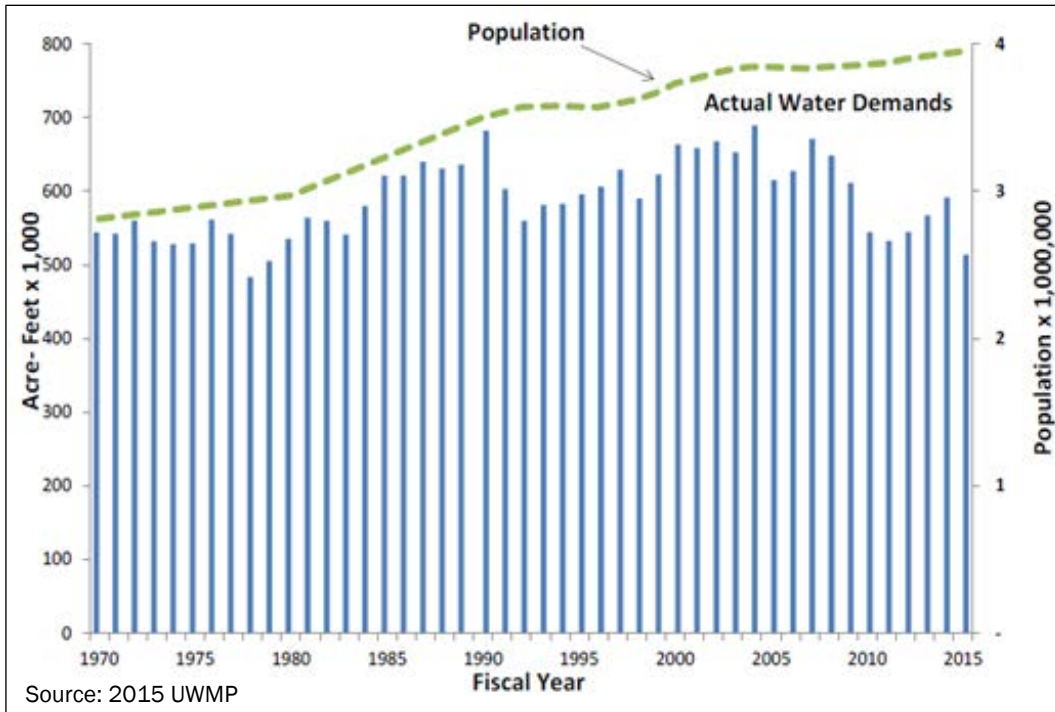

Figure 3.4 Water Demand and Population through Time

Water conservation benefits the City in numerous ways, such as:

- Improvement in water supply reliability.
- Deferment and reduction in the size of water and wastewater system improvements.
- Potential of monetary savings for customers that reduce their water consumption.
- Reduction in dry weather urban runoff from irrigation of landscaping that decreases the amount of pollutants flowing into local rivers and the Pacific Ocean.
- Reduction in energy use for water conveyance (pumping of imported water supplies and within the distribution system), as well as less energy required for water and wastewater treatment.
- Reduction in energy consumption by residents and businesses for water heating/cooling and clothes/dish washing.

The primary beneficiaries of conservation are LADWP's water rate-payers and the natural environment.

In October 2014, Mayor Eric Garcetti issued ED#5. One of the main ED#5 goals was to reduce the City's water use to 104 gallons per capita per day (gpcd) by January 1, 2017. LADWP's water use efficiency accomplishments through the last several decades put the City on a strong foundation, and with the help of Angelinos, the Mayor's ED#5 goal was met.

Building on the momentum of ED#5, the Mayor released the Sustainable City pLAn on April 8, 2015. In addition to incorporating the ED#5 goals, the Sustainable City pLAn includes additional long-term water conservation goals of reducing gallons per capita per day 22.5 percent by 2025 and 25 percent by 2035. These goals have been incorporated by LADWP into its 2015 UWMP.

To help achieve these goals, the City has a multi-faceted water conservation approach that targets both indoor and outdoor uses and reaches across all customer sectors. City conservation programs that are being implemented to achieve these targets are described next.

3.3.1 Existing Conservation Programs

There is a suite of existing conservation methods that serve to reduce water use throughout the City. LADWP, in particular, implements a vast conservation program with conservation measures in the areas of public information, school education, residential, commercial/industrial/government, landscape, system maintenance, and pricing. Existing key strategic conservation strategies include:

Water Loss Reduction Program – In October 2014, LADWP created a Water Loss Task Force to reduce water loss through new initiatives, such as improved pressure management and increased active leak detection. All of these new initiatives are documented in the Water Loss Task Force Action Plan.

Save-the-Drop Campaign – In April 2015, the City launched its Save-the-Drop water conservation outreach campaign, which is a partnership between LADWP and the Mayor's Office. Outreach materials include public service announcements, radio spots, event handouts, and public signage.



Outreach and Education – LADWP has developed extensive public information programs and school education programs. These programs include Los Angeles Times in Education and "Thirsty City" Live Play Performances.



Cash in Your Lawn – The LADWP's Cash in Your Lawn program provides homeowners with rebates to remove thirsty grass and replace it with California-friendly landscaping when also capturing rainfall on-site. Despite having only 10 percent of the State's population, the City has already contributed to more than 95 percent of the State's goal for turf replacement. In addition,

LADWP offers training classes that assist customers in making the switch from turf to sustainable landscapes. An example of California-friendly landscaping is shown on Figure 3.5.

Financial Incentives – For residential customers, LADWP offers rebates for the following devices: high-efficiency washers, premium high-efficiency toilets, weather-based irrigation controllers, and rotating sprinklers. Furthermore, the LADWP gives free water-conserving aerators and showerheads to help customers save money and water in their home. Additionally, the City provides financial incentives for residents to purchase both rain barrels (minimum 50 gallons) and cisterns (minimum 200 gallons), for the purpose of capturing water for on-site reuse.



Figure 3.5 Example of California-Friendly Landscaping

On the commercial side, LADWP provides a large variety of rebates for business customers. Some of the available rebates for commercial devices include premium high-efficiency toilets, zero- and ultra-low-flow water urinals, irrigation controllers, and cooling tower controllers.

Also, LADWP operates a Technical Assistance Program and provides financial incentives for custom water conservation projects. The program offers commercial, industrial, institutional, and multi-family residential customers in Los Angeles up to \$250,000 for the installation of pre-approved equipment and products that demonstrate water savings.

3.3.2 Accomplishments to Date

Existing water conservation strategies have resulted in the following key accomplishments for the City to date:

- Since the start of the LADWP's water conservation program in the 1970s, the City has reduced its water demand by 128,000 AFY.
- Reducing the City's gallons per-capita per-day usage to 104 gpcd, which represents a 20 percent reduction compared to the FY 2013-14 baseline, therefore meeting the Mayor's aggressive ED#5 goal.
- Replacing 48.4 million square feet of turf, thereby reducing water use by 1.9 billion gallons of water per year (approximately 5,800 AF).

3.3.3 Ongoing and Planned Efforts

Existing conservation programs, policies, and ordinances will remain in effect, with ongoing water conservation measures continuing to be implemented. To identify targeted areas of water conservation, LADWP has completed the 2017 Water Conservation Potential Study. This study identifies the City's potential for future indoor and outdoor water conservation measures based on an analysis of current device saturation levels.

The results from the Water Conservation Potential Study are going to help LADWP to develop its long-term strategy to meet the Sustainable City pLAN's 2025 and 2035 gallons per-capita per-day reduction goals.

3.4 GROUNDWATER

Over the past several decades, local groundwater has made up between 10 to 23 percent of the City's water supply. Given the uncertainty of imported water supplies and climate change, local groundwater resources have become increasingly important. However, contamination issues and declining water levels impact the City's ability to fully use the SFB wellfields, which provides the primary groundwater supply for the City. Furthermore, aging wellfields, and aging distribution system infrastructure present challenges to fully utilize the City's local groundwater resources.

The LADWP currently operates three groundwater treatment facilities that treat approximately 20,000 AFY to address groundwater contamination issues in local groundwater basins (see Section 3.4.1). Remediation in the SFB will restore the ability to utilize the groundwater basin, which

is key to future groundwater supply development such as the GWR Project (see Section 3.5.3) and stormwater capture projects (see Section 3.6.4). Collectively, these efforts will help the City with its goal of increasing local groundwater supplies and guarding against future drought conditions.

Per the 2015 UWMP, the City's total groundwater production is planned to reach 114,070 AFY by 2040. This projection does not include the additional pumping attributed to the GWR Project and any stormwater recharge projects implemented.

3.4.1 Overview of Groundwater Basins

Local groundwater is a key resource that the City has relied upon as a major component of its water supply portfolio. The City pumps groundwater from three groundwater basins: San Fernando, Sylmar, and Central. Also, the City overlies four other groundwater basins that are currently not used by the City for potable groundwater production, namely the Eagle Rock, Santa Monica, Hollywood, and West Coast Basins. These seven groundwater basins are shown on Figure 1.7.

The average annual production capacity by basin for the period of fiscal year (FY) 2010/11 through FY 2014/15 is depicted on Figure 3.6. As shown, the total average production in the period was 67,135 AFY, which represents approximately 12 percent of the total water supply for the City over the same five-year period. As shown, the SFB provided the vast majority of the City's groundwater production (88 percent or 58,741 AF). The following paragraphs provide a brief description of each groundwater basin.

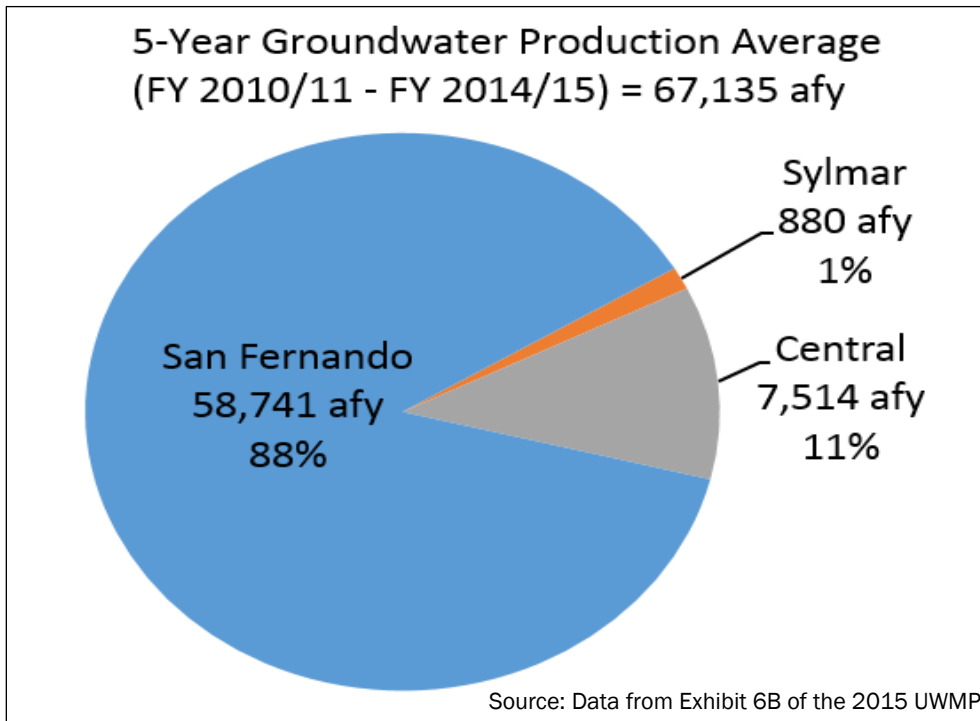

Figure 3.6 Average Five-Year Groundwater Production by Basin

3.4.1.1 San Fernando Basin

The LADWP has 10 wellfields within the SFB, containing a total of 115 wells, with only approximately 30 reliable wells operated at any given time. Based on size and production, the wellfields can be grouped as follows:

- **Tujunga, Rinaldi-Toluca, North Hollywood West, and North Hollywood East Wellfields** – these are the largest and primary wellfields
- **Erwin, Verdugo, and Whitnall Wellfields** – these wellfields provide groundwater pumping flexibility and additional groundwater production capacity
- **Pollock Wellfield** – provides a small amount of groundwater production capacity
- **Crystal Springs and Headworks Wellfields** – historically provided additional pumping capacity, but are no longer in service

Groundwater contamination caused by historical industrial activities in the area has severely degraded groundwater quality in the basin, adversely affecting the use of the groundwater, and requiring cleanup and remediation for environmental and public benefit as well as to prevent further loss of this local water resource. The City is undertaking a remediation program to restore the beneficial use of the SFB to address the organic and inorganic contaminants of concern present (i.e., trichloroethylene [TCE], tetrachloroethylene [PCE], 1,4-Dioxane, hexavalent chromium [Cr(VI)], perchlorate, carbon tetrachloride, nitrate, and others).

The City has recently completed pilot testing, design, and environmental documentation for the GWR Project, which is anticipated to recharge the SFB with up to 30,000 AFY of recycled water from the DCTWRP. More details regarding this project are discussed in Section 3.5.3.

3.4.1.2 Sylmar Basin

The Mission Wellfield in the Sylmar Basin has a total of seven wells, with five of them built between 1961 and 1977, and the remaining two built before 1961. However, only two wells are operable, of which one has been removed from service due to groundwater contamination from primarily TCE. The Mission Wells Improvement Project is installing three replacement wells and associated infrastructure to restore groundwater use and pumping capacity in the basin.

3.4.1.3 Central Basin

The City pumps groundwater from two Central Basin wellfields: the Manhattan and 99th Street Wellfields.

- **Manhattan Wellfield** – The six wells in the Manhattan Wellfield were installed between 1928 and 1974. However, only two wells remain active. The Manhattan wells are approaching the end of their useful life, experiencing mechanical deterioration and water quality issues. The Manhattan Wells Improvement Project is restoring the City's pumping capacity and addressing groundwater contamination issues (primarily TCE). This project will result in the rehabilitation and/or construction of up to eight production wells, along with related infrastructure (pipeline, electrical upgrades, and supervisory control and data acquisition). These improvements are currently underway.

- **99th Street Wellfield** – The four active wells in the 99th Street Wellfield were installed between 1974 and 2002. Although this wellfield does not have the industrial contamination issues that exist in the Manhattan Wellfield, it does contain high amounts of iron and manganese. The wellfield is currently not operating due to construction of new chloramination facilities to be followed by construction of iron and manganese treatment facilities.

3.4.2 Maximizing Utilization of Other Groundwater Basins

In addition to the three groundwater basins described in the previous section, the City overlies four other basins that are currently not used for potable groundwater production. These include the Eagle Rock Basin, West Coast Basin, Santa Monica Basin, and Hollywood Basin. The locations of these basins are depicted on Figure 1.6.

Due to the emphasis of developing more local water supplies, there is a renewed emphasis on utilization of other local groundwater basins that the City does not currently produce groundwater from. Moreover, with the passing of the Sustainable Groundwater Management Act (SGMA) in September 2014, the California Department of Water Resources (DWR) launched the Sustainable Groundwater Management (SGM) Program to implement the law and provide ongoing support to cities with land overlaying unadjudicated groundwater basins that are required to sustainably manage their basins. SGMA requires groundwater-dependent regions to halt overdraft and bring basins into balanced levels of pumping and recharge. Adjudicated basins are those where parties owning property have a right to pump groundwater from the underlying aquifers, and the limited management pumping is defined by the adjudication.

Throughout the development of SGMA, there was broad public consensus that adjudicated basins are well managed, subject to Court jurisdiction, and should not be the primary focus for SGMA. Therefore, the new law only requires managers of adjudicated basins to file a copy of the adjudication with DWR and the annual reports that document basin conditions. Los Angeles overlies both adjudicated and unadjudicated basins; therefore LADWP is working with its regional partners to implement SGMA plans for the unadjudicated basins that are located within the City's boundaries.

SGMA revised the Water Code to direct the DWR to develop a groundwater basin priority, ranging from very low to high priority for all groundwater basins. Prioritization will be used to align resources in the implementation of the California Statewide Groundwater Elevation Monitoring Program, whereby DWR is going to focus on high- and medium-priority groundwater basins first. The characteristics and SGMA priority status of the groundwater basins that the City currently does not use for production are described next.

- **Eagle Rock Basin** – This basin has a very small estimated safe yield of approximately 500 AFY. Given the limited yield, the City does not foresee producing groundwater from this basin at this time. The basin's SGMA priority status is medium.
- **West Coast Basin** – The West Coast Basin is an adjudicated basin that is managed by the Water Replenishment District (WRD). The City owns one wellfield, the Lomita Wellfield. This wellfield has been impacted by localized groundwater contamination and deterioration of water quality (total dissolved solids [TDS], hydrocarbons, and chlorides), such that LADWP has

discontinued operation, and there has not been any City pumping since 1980. The basin's SGMA priority status is medium.

- **Santa Monica Basin and Hollywood Basin** – These two basins are unadjudicated, and the City does not have any production wells in either. Both have some groundwater contamination issues. The Santa Monica Basin has been impacted by methyl tertiary butyl ether [MTBE], VOCs, and elevated TDS. The Hollywood Basin has been affected by localized VOC contamination and also has elevated TDS. Per SGMA, Santa Monica Basin is a medium-priority basin, while the Hollywood Basin is a very-low-priority basin. Any future groundwater development by the City would be anticipated to proceed in a manner that is locally sustainable, in cooperation with these local partners and in accordance with the SGMA.
- **Northern Portion of the Central Basin** – There is an unadjudicated northern area of the Central Basin that is considered a high-priority basin by SGMA.

LADWP is moving forward in collaborating with municipalities and agencies overlying these basins to comply with the SGMA and evaluate how it can maximize utilization from other groundwater basins.

3.5 RECYCLED WATER

Recycled water is highly treated wastewater that is approved for non-potable reuse, such as irrigation of golf courses, cemeteries, freeway medians, and other large landscapes. It is also approved for other uses, such as street sweeping, industrial cooling, dust control, concrete, groundwater replenishment, and environmental benefits. Implementation of recycled water projects is progressing and expected to fill a larger role in Los Angeles' water supply portfolio.

The City built its first water recycling infrastructure in the early 1980s. Today, the City serves more than 50 large-scale customers with recycled water for irrigation, industrial, and environmental beneficial uses. The combined recycled water demand for these non-potable and environmental beneficial uses is approximately 10,000 AFY and 25,000 AFY, respectively.

The 2015 UWMP set a goal to supply 75,400 AFY of recycled water by 2040, which is projected to constitute approximately 12 percent of the total City supply mix, compared to just 2 percent today. To achieve this goal, the City continues to look for cost-effective opportunities to expand its recycled water program through the growth of its recycled water pipeline (purple pipe) network. Additionally, the planned implementation of the GWR Project in the SFB plays a key role to achieve this goal. In addition, this Plan also includes a preliminary evaluation of concept ideas for Potable Reuse, which is described in more detail in Chapter 6.

The following sections provide a more detailed description on the recycled water supply sources, existing recycled water uses, and ongoing recycled water projects.

3.5.1 Recycled Water Supply Sources

The City's wastewater collection system conveys wastewater from both City customers and 29 contract agencies that discharge their wastewater at various locations into the City's sewer system. In turn, wastewater is treated at the City's four water reclamation plants (WRPs): the DCTWRP, with a capacity of 80 mgd, the Los Angeles-Glendale Water Reclamation Plant (LAGWRP) (20 mgd), the Terminal Island Water Reclamation Plant (TIWRP) (30 mgd), and the Hyperion Treatment Plant (HTP) (450 mgd). After various levels of treatment, the recycled water is then supplied to recycled water customers throughout the City. In addition to the City's four WRPs, the City receives recycled water from the City of Burbank in exchange for groundwater pumping water credits.

The City has the following four recycled water service areas:

- **Harbor** – located in the southern portion of the City and currently served by TIWRP
- **Metro** – located in the central/eastern portion of the City and served by LAGWRP
- **Valley** – located in the northern portion of the City and served by DCTWRP
- **Westside** – located in the central/ western portion of the City and served by Hyperion Water Reclamation Plant (HWRP) through the West Basin Municipal Water District's (WBMWD) Edward C. Little Water Recycling Facility (ECLWRF).

The treatment capacity, average wastewater flows, and potential recycled water supply are summarized in Table 3.1. Note, LASAN provided the potential recycled water supply values for year 2016. The existing recycled water system and location of the WRPs are shown on Figure 3.7.

Table 3.1 Potential Recycled Water Supply Summary by Plant Summary Report One Water LA 2040 Plan					
	Units	DCTWRP	LAGWRP	HWRP	TIWRP
Rated Capacity	mgd	80	20	450	30
Average Annual Wastewater Flow (CY 2015) ⁽¹⁾	AFY	51,475	19,265	289,011	18,394
	mgd	47	17	250	14
Potential Recycled Water Supply ⁽²⁾	mgd	28	16	286	19
	AFY	31,000	17,365	320,490	21,792
Notes:					
(1) Values from TM 2.1 Table 11.					
(2) LASAN provided the potential recycled water supply values for 2016.					

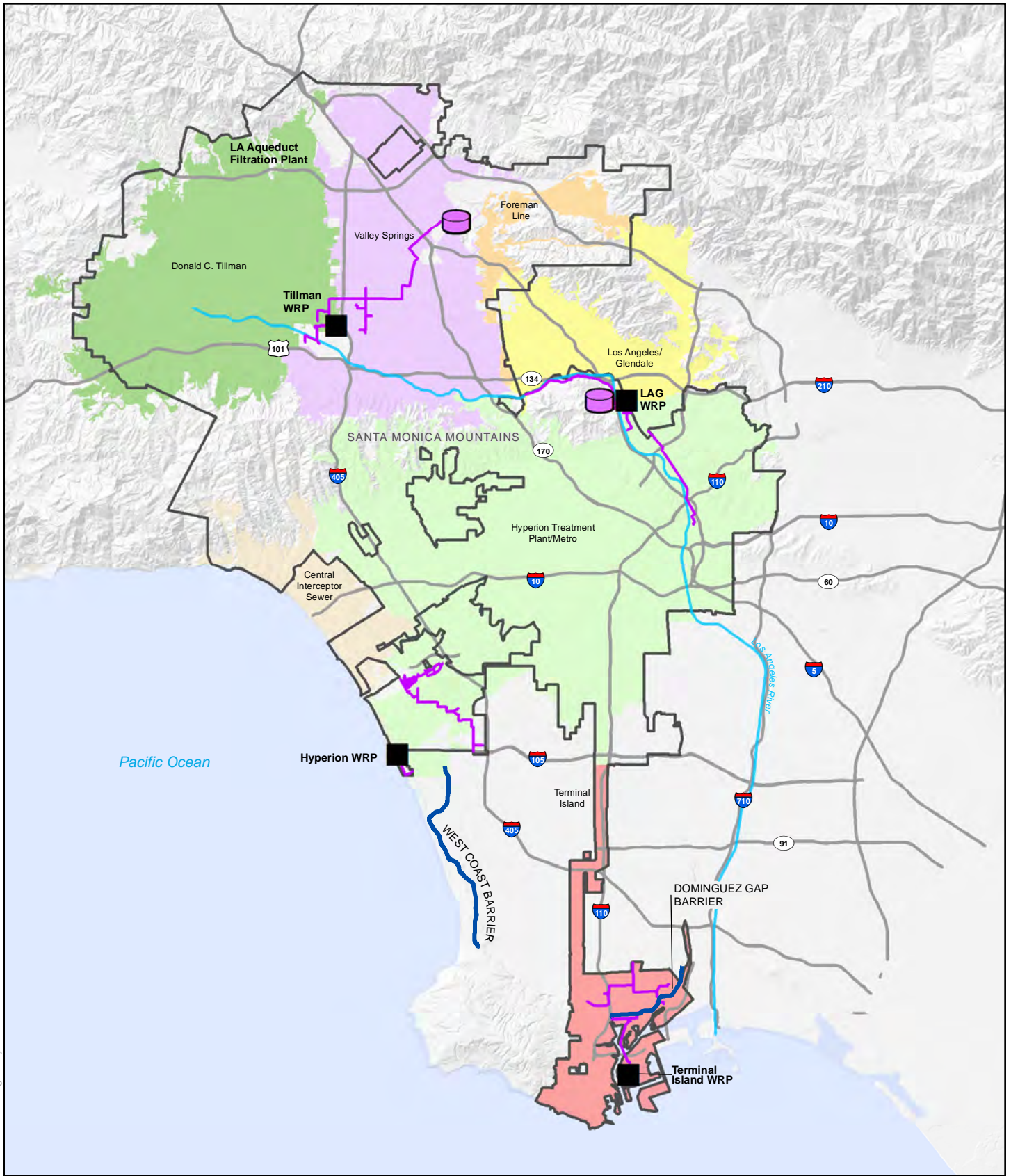

Legend

- Existing Water Reclamation Plant (WRP)
- City of Los Angeles
- Sewershed Source: LASAN
- Existing Recycled Water Tank
- Existing Recycled Water Pipes
- Seawater Barrier



0 1.5 3
Miles

Hillshade Source: CalAtlas
<http://www.atlas.ca.gov>

Figure 3.7 - Existing Recycled Water System and Facilities

One Water LA 2040 Plan
Summary Report

3.5.2 Existing Non-Potable Reuse

The City currently recycles more than 35,000 AFY of water, using it for non-potable use such as irrigation, industrial purposes, environmental beneficial reuse (i.e., Japanese Gardens and Balboa Lake), and injection at seawater intrusion barriers, including the West Coast Barrier and Dominguez Gap Barrier, both shown on Figure 3.7. The City owns 62 miles of purple pipe and supporting infrastructure to deliver over 10,000 AFY of recycled water to its non-potable customers and approximately 25,000 AFY to environmental uses. The existing recycled water distribution system and the four WRPs that produce the recycled water are depicted on Figure 3.7.

The total non-potable reuse demand nearly doubled in the past decade from 5,151 AFY in 2006 to 9,913 AFY in 2016. A historical summary of recycled water use is shown on Figure 3.8.

3.5.3 Accomplishments to Date

Since the completion of the 2006 Water IRP, the City has completed and started with a variety of regional partnerships and projects to increase the use of recycled water to offset potable water supplies. These projects are briefly described below in chronological order.

City Programs – The One Water LA team worked with five City departments and was able to modify four structural specifications that allow the use of recycled water in concrete. Additional collaboration with industry and State agencies resulted in the ability for contractors to utilize recycled water and potentially save money to be more competitive in City projects where concrete is required.

Regional Partnerships – The City has worked with other regional agencies to advance the use of recycled water. The first partnership was formed with the City of Glendale. Joint use of the LAGWRP began in 1976, with the City and Glendale having equal rights to the recycled water supplies. In 1982, LADWP began delivering tertiary quality recycled water to the Department of Recreation and Parks for irrigation of various areas in Griffith Park. This service was later expanded to include Griffith Park's golf courses.

In early 2017, the City also reached an agreement with West Basin Municipal Water District, to increase the delivery capacity to a maximum of 70 mgd from HWRP to their ECLWRF to further treat the water and distribute it through their extensive recycled water system.

The City has recently completed the installation of recycled water distribution systems that are connected to the City of Burbank's recycled water system. This system will begin to deliver recycled water to customers in the North Hollywood area.

The City plans to explore additional partnership efforts with other utilities to develop future integration opportunities in order to maximize recycled water use to 45,400 AFY by 2040 for non-potable reuse purposes. As shown on Figure 3.8, the 2015 UWMP projects that the City's recycled water demand increases to 75,400 AFY by year 2040 also include 30,000 AFY of groundwater recharge from the SFB groundwater recharge project.

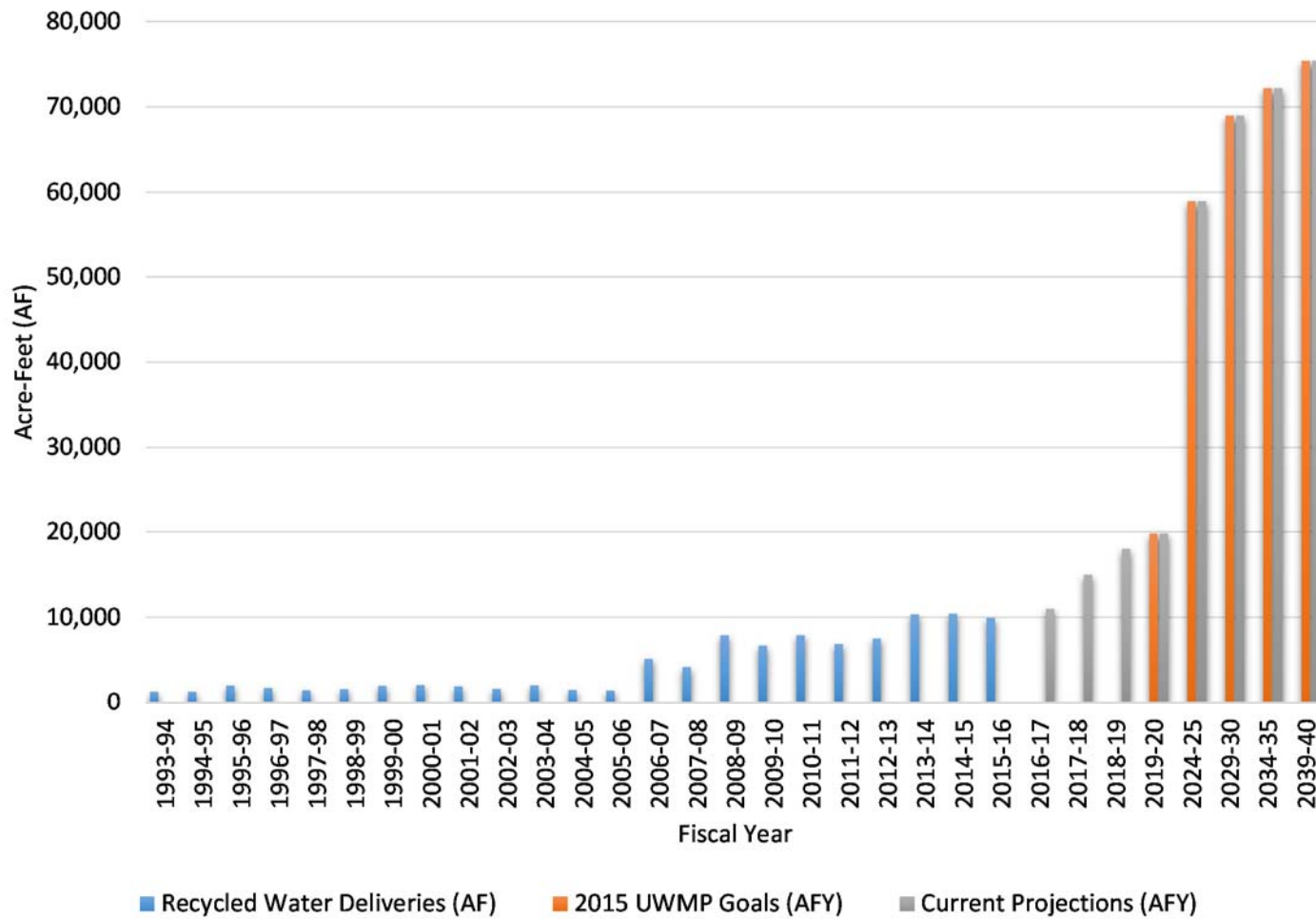

Source: Developed from Table in Recycled Water Annual Report (LADWP, 2016)

Figure 3.8 - Recycled Water Deliveries through Time
 One Water LA 2040 Plan
 Summary Report

Terminal Island Water Reclamation Plant Expansion – Since 2006, the TIWRP has supplied nearly 4 mgd of advanced treated recycled water to the Dominguez Gap Barrier, which prevents seawater intrusion into the West Coast Groundwater Basin. In 2016, LASAN completed the plant expansion, doubling its treatment capacity from 6 to 12 mgd. This expansion will allow the City to deliver the Dominguez Gap Barrier with its total needs, eliminating the need for potable water as a supplement. The facility is going to now also supply various harbor-area industrial users with recycled water and send water to Machado Lake to replenish water lost from evaporation.

Groundwater Replenishment Project – The GWR Project is currently in the planning stages and, when complete, is anticipated to provide up to 30,000 AFY of recycled water from DCTWRP to replenish the SFB. Existing and new recycled water pipelines would convey purified water to the Hansen and Pacoima Spreading Grounds in the eastern San Fernando Valley, replenishing the SFB and its aquifers. Infiltrated water would travel underground as groundwater for several years until it is pumped out by existing groundwater wells to supplement the City's local water supplies. To date, the City has conducted extensive pilot testing of various treatment processes to comply with state regulations for groundwater replenishment. This project is planned to be operational in 2023-2024.

3.6 STORMWATER

Stormwater capture is anticipated to be an important part of the City's overall plan to improve water quality in its watersheds and enhance its local water supply. Rainfall and runoff can be captured from open space and urban lands for water quality benefits, direct use such as irrigation purposes, or for future use by allowing the water to percolate into groundwater basins.

The City's stormwater mission is to protect receiving water bodies while complying with flood control and pollution regulations. The 2006 Water IRP brought a new perspective to stormwater as an important resource. Since then, the City has prepared and been involved in multiple large stormwater management planning efforts, such as the 2015 SCMP, five EWMPs for each of the different watersheds (see Figure 1.4), and the 2016 Los Angeles Basin Stormwater Conservation Study (U.S. Bureau of Reclamation [USBRE], 2015). The purpose of these plans varied and included the identification of stormwater projects and programs to increase the use of stormwater as a local water supply source, manage flooding, and enhance downstream water quality.

These studies formed the foundation for the Stormwater and Urban Runoff Facilities Master Plan that has been developed as part of this Plan. This Stormwater Facilities Plan has the unique approach that combines three stormwater management objectives, namely stormwater quality compliance, flood risk mitigation, and water supply benefits. This "three-legged stool approach" and the findings of the Stormwater Facilities Plan are summarized in Chapter 8, while the entire Facility Plan is included as Volume 3.

3.6.1 Watersheds

Due to topography, the City's stormwater generation and management strategies are typically identified and described by major watershed. The City overlies portions of five different watersheds. These watersheds are described in Chapter 1 and shown on Figure 1.5.

Today, approximately 64,000 AFY of stormwater is captured, recharged, or reused from active centralized capture and natural infiltration. However, the vast majority of stormwater runoff is not currently captured and flows into the Pacific Ocean via the City's storm drain system, a variety of creeks, and the LA River.

3.6.2 Stormwater Quality Goals

The EWMPs not only facilitate a comprehensive approach to stormwater planning to retain or reuse stormwater, enhance flood protection, promote water conservation efforts, but also incorporates State agency regulations in the watershed by providing clear compliance timelines to address stormwater and receiving water quality issues. The water quality prioritization process identifies and prioritizes water quality impairments in the watershed based on review of available monitoring data. Based on permit requirements, the following categories of water body-pollutant combinations (WBPCs) are identified:

- **Category 1** are those subject to an established TMDL.
- **Category 2** are those on the State Water Resources Control Board 2010 Clean Water Act Section 303(d) list or those constituents that have sufficient exceedances to be listed.
- **Category 3** are those with observed exceedances in its dataset, but too infrequent to be listed, and conditions that are not pollutants.

The purpose of each EWMP is designed to address all the identified Water Quality Priorities through a network of stormwater control measures to capture stormwater runoff for treatment or infiltration. These control measures are described further below.

3.6.3 Existing Stormwater Capture and Use Methods

Despite limited annual rainfall in the region, the City has an extensive stormwater collection system to manage flooding risk and capture dry weather/urban runoff to accommodate varying degrees of intense rainfall that typically occur in winter months. The City generates an average of 415,000 AFY of stormwater runoff (LADWP SCMP, 2015). During dry and wet years, stormwater flows range from 114,000 AFY to 1,000,000 AFY, respectively. The stormwater infrastructure system within the City works collectively to provide multiple benefits to the public at-large, and includes both grey and green infrastructure.

Grey infrastructure is the stormwater conveyance and detention infrastructure that has historically been designed to provide flood protection by collecting runoff, detaining collected runoff to attenuate peak discharge rates when necessary, and ultimately conveying runoff away from City property to downstream receiving waters, including oceans, reservoirs, spreading basins, and groundwater aquifers.

Green infrastructure is composed of both nature-inspired and mechanical systems that are designed to mimic natural processes to retain, infiltrate, and/or treat runoff, thereby providing multiple benefits including, but not limited to, flood protection, water quality improvement, and water supply benefits.

Over the past 25 years, there has been an increase in considering stormwater as a resource in the City. As a result, the creation of green infrastructure projects that capture runoff for various purposes has increased. Example benefits of the captured water include improved watershed quality, flood control, irrigation, groundwater recharge, and other potable water offsets. These alternate uses have led to the development of Best Management Practices (BMPs), including green streets, low-impact development (LID) features, rainwater harvest systems, 25 Prop O projects in the City, and numerous EWMP projects. Along with detention basins, these green infrastructure projects work together to improve water quality, provide water supply benefits, and prevent flooding in urbanized areas. Green infrastructure can be further grouped into centralized, regional, and distributed projects. These groups are defined as:

- **Centralized Projects** are large-scale projects that are individually planned and designed to capture or treat stormwater and/or non-stormwater from large drainage areas that include multiple parcels and various land uses. Examples of centralized projects include dams, reservoirs, spreading grounds, and debris basins. The Hansen Spreading Grounds are shown on Figure 3.9.
- **Regional Projects** are large-scale projects that are individually planned and designed to capture or treat stormwater and/or non-stormwater from mid-sized to large drainage areas that include multiple parcels and various land uses. Regional projects consist of nature-inspired and mechanical BMPs. Examples of regional projects include retention basins/infiltration basins (including spreading grounds); capture, storage and use systems; nature-inspired flow-through treatment systems, such as wetlands; and low flow diversions. Regional projects can be implemented on both private and public parcels. However, most watershed planning efforts prioritize project locations on public parcels to avoid the significant land acquisition cost.
- **Distributed Projects** refer to small-scale green infrastructure projects that are designed to treat stormwater and urban runoff from small drainage areas, which are usually comprised of one to a few parcels. Distributed projects are an essential component to the EWMP implementation strategies and include a variety of solutions, such as small-scale detention, green infrastructure (i.e., porous pavement, infiltration trenches, drywells, cisterns, and bioretention/bioswales/biofilters), flow-through BMPs (i.e., downspout filters, flow-through planters, and proprietary units), and source controls (i.e., catch basin retrofits and proprietary units). Green streets and LID are common applications of distributed structural projects.
 - Green streets/green alleys are one common application of distributed structural projects. Examples of green streets projects include installing linear bioretention/bioswales in parallel to roads, retrofitting catch basins to intercept various pollutants, incorporating dry wells, and using pervious pavement material. By installing these structures, the green street project can capture stormwater and dry weather runoff from the gutter via curb cuts or curb extensions.
 - Parcel-based solutions are also an important part of the distributed green infrastructure program to help the City accomplish its stormwater goals. Many of the Plan's recommended policies, summarized in Chapter 9 are intended to increase implementation and improve the performance of distributed BMPs. The incorporation of small-scale BMPs such as bio-retention, permeable pavement, or rainfall harvesting

systems that capture, treat and/or store rainfall on multiple individual parcels can collectively make a significant impact. The practices can be implemented through retrofit of existing properties or through implementation of the City's Low Impact Development (LID) Ordinance, which requires distributed stormwater solutions for development and redevelopment projects.



Figure 3.9 Hansen Spreading Grounds

A more detailed description of the variety of stormwater management solutions are described in Chapter 8, as well as in Volume 3.

3.6.4 Accomplishments to Date

Today, on average, approximately 29,000 AFY of stormwater is actively captured at centralized spreading grounds to recharge groundwater. Additionally, approximately 35,000 AFY is infiltrated into groundwater aquifers through incidental recharge. In combination, this is 64,000 AFY of stormwater being captured, recharged, or reused,

Future targets include capturing 150,000 AFY by 2035 and identifying funding mechanisms and performance metrics to implement stormwater capture as identified in the SCMP and EWMPs.

The key accomplishments to date since the completion of the 2006 Water IRP for each of the stormwater management strategies are summarized below.

Prop O Projects – Prop O-funded projects are represented in one or more of the following categories:

- Water-quality protection of rivers, lakes, beaches, bays, and the ocean
- Water conservation, drinking water, and source protection
- Flood water reduction, including river and neighborhood parks that prevent polluted runoff and improve water quality
- Stormwater capture, cleanup, and re-use

To date, approximately \$288 million has been spent implementing Prop O projects across the City. Examples include the signature projects such as the Echo Park Lake Revitalization Project, South Los Angeles Wetlands Park, Hansen Dam Wetland Restoration, Machado Lake Ecosystem Rehabilitation, Penmar Park Subsurface Stormwater Storage, Mar Vista Recreation Center stormwater infiltration BMP, and the LA Zoo Green Parking Lot Stormwater Infiltration (Figure 3.10).

Enhanced Watershed Management

Plans – The City collaborated with nearly 30 other government agencies to prepare an EWMP for each of the five watersheds within LA County. The City has moved forward with several of the recommended projects identified in each of the EWMPs, such as Rory Shaw Wetlands, Broadway, and Avalon Green Streets.

Green Streets/Green Alleys – This program integrates distributed and regional projects with multi-purpose green solutions designed to improve water quality, augment water supply,

manage floods, enhance habitat, and provide for open space. The program includes rainwater harvesting and greenways systems to maximize stormwater capture and infiltration on public and private land. An example of a Green alley is shown on Figure 3.11.



Figure 3.10 LA Zoo Parking Lot Stormwater Infiltration



Figure 3.11 Example of a Green Alley

Low Impact Development Ordinance –

In May 2012, the City of Los Angeles LID Ordinance went into effect, requiring all development and redevelopment projects that create, add, or replace 500 square feet (sq ft) or more of impervious area to capture the 3/4-inch rain event for infiltration or reuse on-site. Single-family residences can comply in a more simple way by installing rain barrels,

permeable pavement, rainwater storage tanks, or infiltration swales. The County of LA amended its LID Ordinance in 2013, requiring the use of LID principles in all development projects except road and flood infrastructure projects. The City is currently working on an LID ordinance for private developments to ensure that parcel-based development and redevelopment projects on private properties mitigate the impacts of runoff and stormwater pollution.

3.7 LOS ANGELES RIVER

In 1938, after the Los Angeles Flood inundated much of Los Angeles and adjacent cities, the US Army Corps of Engineers began channelizing local streams and building more flood control dams. Although the river's current primary function is flood control, ongoing efforts to revitalize the river with ecosystem and recreational functions have been ongoing for decades, with some segments of the 51-mile river already being restored to provide a more natural habitat and opportunities for biking and kayaking.

Before the opening of the LAA, the LA River was the primary source of fresh water in the City. Revitalization of this important waterway is closely tied to meeting water quality objectives.

The LA River, shown on Figure 3.12, is 51 miles in length, of which the first 32 miles traverse within the City boundary. The LA River is considered to begin at the confluence of Bell Creek and Calabasas Creek, which flow down from the Santa Susana and Santa Monica Mountains in the Canoga Park section of the City. The river flows southeast and is joined by the Santa Susana, Browns, Dayton, Chatsworth, Limekiln, Wilbur, Aliso, Woodley, Pacoima, and Burbank Creeks that drain the surrounding mountains. The main trunk of the LA River is considered to begin in the southwest portion of the SFB, flowing eastward near the northern slopes of the Santa Monica Mountains, and then it turns south through the LA River Narrows. Once out of the Upper Los Angeles River Area (ULARA), the river flows south through the Central and West Coast basins of the Los Angeles Coastal Plain and discharges to the Pacific Ocean near Long Beach.

The LA River has about 85 miles of natural tributary washes within the ULARA. In general, the tributary washes to the LA River in the SFB do not flow continuously because they carry water only as a result of seasonal storm runoff or industrial discharges. Big Tujunga Creek, Little Tujunga Creek, Arroyo Seco, and Pacoima Creek are the most prominent tributaries of the LA River as shown on Figure 3.12. Nearly half of the runoff from the entire hill and mountain area is carried by these tributaries. Most of the LA River and its main tributaries (more than 60 percent) have concrete-lined channels for flood-control purposes. The unlined portions of the river total approximately 8.5 miles and are located in the following three areas. A photo of the soft-bottomed river is provided as Figure 3.13:

- Through the Sepulveda Flood Control Basin in the San Fernando Valley (3 miles)
- Near Griffith Park through Elysian Valley where groundwater levels prevent it from being paved (2.5 miles)
- At the River estuary in Long Beach where the river empties into the Pacific Ocean (3 miles)

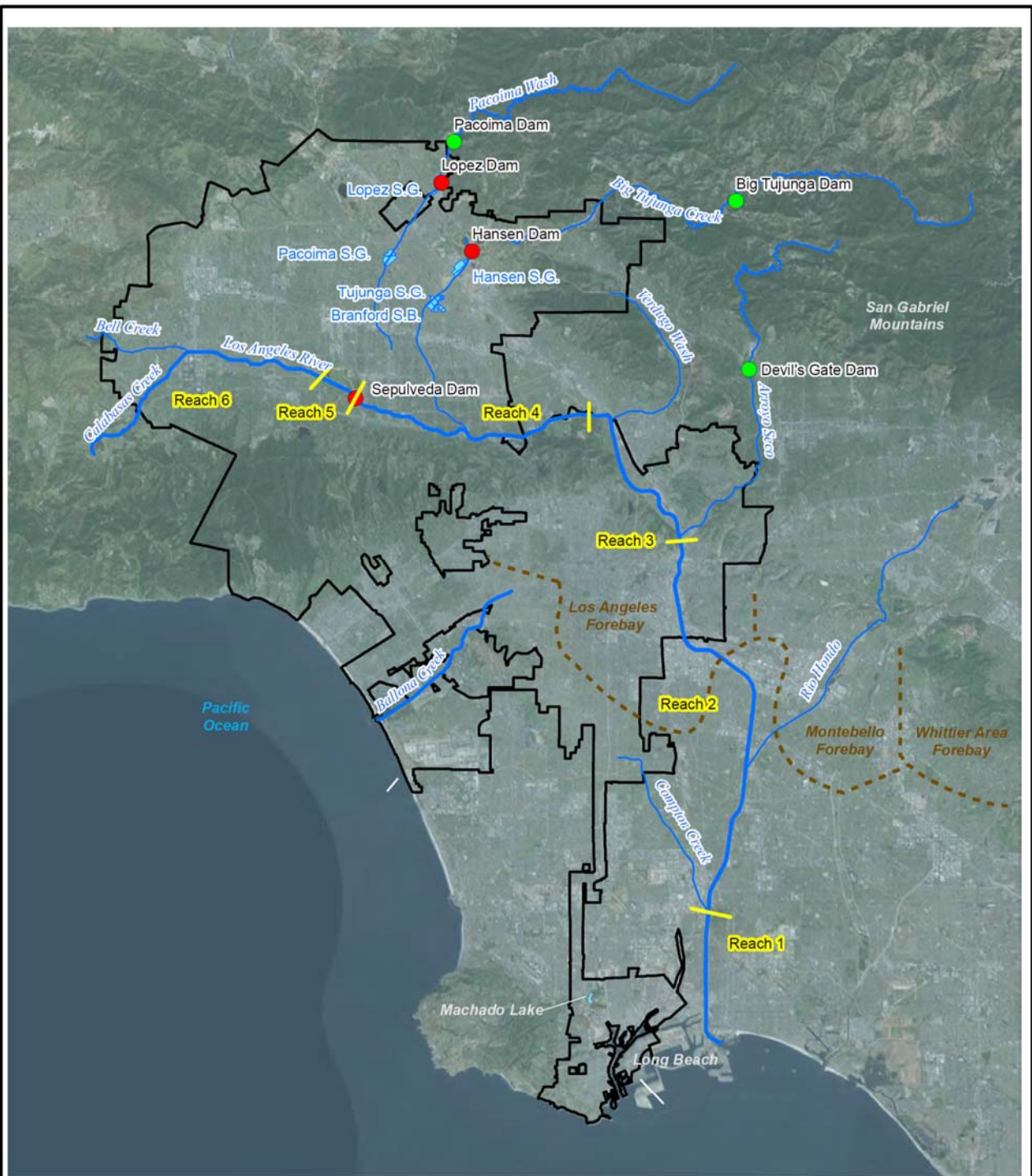

Legend

- LA County Dams
- USACE Dams
- LA River
- Central Basin Sub-Area Boundary
- Spreading Grounds
- LA City Boundary



Figure 3.12 - LA River and Major Creeks
 One Water LA 2040 Plan
 Summary Report



Figure 3.13 Example of Unlined Portion of LA River

3.7.1 LA River Reaches

The Los Angeles Regional Water Quality Control Board (RWQCB) has subdivided the LA River into six reaches. These reaches are shown on Figure 3.12 and summarized below, while a more detailed description can be found in the Los Angeles County River Master Plan (LA County, 1996). The six reaches of the LA River are:

- **Reach 1: Southern Cities** – This is a 9-mile reach from Atlantic Avenue to the Ocean, including the cities of Carson and Long Beach. The entire reach is a trapezoidal concrete channel defined by earthen levees. From Willow Street south, the river is soft-bottomed with areas of riparian vegetation.
- **Reach 2: Mid Cities** – This reach runs for 11.5 miles from Washington Boulevard south to Atlantic Avenue, including the cities of Vernon, Maywood, Bell Gardens, Bell, Commerce, Cudahy, South Gate, Downey, Lynwood, Paramount, and Compton. In the City of Vernon, the concrete channel changes from rectangular to trapezoidal, with levees on both sides. This change marks the river's outlet into the Coastal Plain.
- **Reach 3: Downtown Los Angeles** – This 5-mile reach spans the area between the Arroyo Seco and Washington Boulevard, including the City neighborhoods of Boyle Heights, Lincoln Heights, Chinatown, and the downtown area. The river consists of a rectangular or trapezoidal concrete channel.
- **Reach 4: Glendale Narrows** – This is a 10-mile reach between Barham Boulevard and the confluence with the Arroyo Seco near Interstate 110, passing through the cities of Burbank, Glendale, and the City communities of Los Feliz, Atwater Village, Elysian Valley, Silverlake,

Glassell Park, and Cypress Park. The river configuration is trapezoidal except for a portion through Glendale.

- **Reach 5: San Fernando Valley** – The LA River flows for approximately 16 miles in the reach along the base of the Santa Monica Mountains, passing through the City communities of Canoga Park, Winnetka, Reseda, Encino, West Van Nuys, Sherman Oaks, Studio City, and Toluca Lake. The channel is rectangular, varying in width from 140 feet to more than 215 feet.
- **Reach 6: Tujunga Wash** – This reach includes the City communities of Lakeview Terrace, Sun Valley, Panorama City, Van Nuys, and North Hollywood. Its northern boundary is at Hansen Dam, while the southern boundary is the confluence of Tujunga Wash and the LA River. The wash is a rectangular concrete channel, varying in width from 60 to 70 feet at its base.

As shown on Figure 3.12, the LA River traverses the City of Los Angeles from Reach 6 through the upstream portion of Reach 2. A large portion of stormwater and dry-weather runoff that is generated within the City boundary is routed to the LA River via a network of storm drains. In addition, the City contributed to the flows in the river with discharges from the DCTWRP and LAGWRP. Additional flows that enter the LA River in the lower portion of Reach 2 and Reach 1 are routed from adjacent cities, such as the City of Long Beach.

3.7.2 Existing LA River Studies and Plans

LARiverWorks, a specialized team within the Mayor's office, is charged with revitalization of the LA River and ecosystem restoration. Water-related projects identified include river revitalization, ecosystem restoration, landscaping, sustainable design, and flood water management. There are many recent and ongoing studies prepared since the completion of the 2006 Water IRP. Some of the key studies and projects are summarized below.

- **Los Angeles River Revitalization Master Plan** – In 2007, the City prepared the LA River Revitalization Plan, which provides a long-term framework for restoring the river's ecological function and transforming it into an amenity for residents and visitors to the City. Some of its goals include enhancing flood storage and water quality, as well as restoring the river to a functional ecosystem. In addition, the plan involves recommendations for physical improvements to the river corridor and the green space network in adjacent neighborhoods. This plan is aimed at enhancing existing communities by creating a safe environment with more open space, parks, trails, recreation, environmental restoration, riverfront living and commerce, new jobs, neighborhood identity, economic development, tourism, and civic pride. The plan outlines strategies, recommendations, and projects to connect neighborhoods within the LA River corridor. With the release of the Sustainable City pLAN, the City has set a goal to restore at least 11 miles and provide 32 miles of river access by 2025.
- **LA Greenway 2020** – This is a movement to connect all 51 miles of the LA River by 2020, from Canoga Park to Long Beach, using the riverbank as a continuous 51-mile active transportation and recreational corridor.
- **Los Angeles River Ecosystem Feasibility Study** – This project is also known as the ARBOR (Alternative with Restoration Benefits and Opportunities for Revitalization) and is led by the United States Army Corps of Engineers (USACE), which involves restoring 11 miles of the

LA River from Griffith Park to downtown Los Angeles. Restoration measures include creating and reestablishment of historic riparian habitat and reintroduction of ecological and physical processes to create a more natural hydrologic regime.

- **LA River Flow Study** – As part of the Plan, this flow study was prepared (see Volume 4). The purpose of this study is to identify considerations, assumptions, and areas of future study necessary to determine optimal flow conditions in the LA River. These conditions would balance the City's water supply needs with the LA River's water-dependent uses and regulatory requirements. To this end, this study summarizes available inflow sources to the LA River, the low-flow conditions, the water budget need to support the Arbor Study, adaptive water management alternatives, as well as benefits, challenges, limitations, and costs for different alternatives.
- **LA River Bike Path** – The Los Angeles River Bike Path connects approximately 7 miles from the north side of Griffith Park at Riverside Drive along the LA River to Barclay Street in Elysian Valley, north of Downtown LA. There is a proposed project to incorporate green infrastructure components into the LA River Bike Path, including: bioswales, permeable pavement, and planter boxes, in order to collect stormwater runoff from impervious or compacted areas for infiltration.
- **UCLA's LA Sustainable Water Project: LA River Watershed** - UCLA was selected by the City to evaluate three of the watersheds within the City. The purpose was to explore the potential to attain compliance with water quality standards while also integrating complementary one water management practices that can increase potential local water supplies for the City in the LAR Watershed. This LA Sustainable Water Project Los Angeles River Watershed report, is part of the UCLA's Sustainable LA Grand Challenges effort. This work complements the One Water LA 2040 Plan as it evaluates the entire watershed and a host of possible BMP scenarios as well as looks at recycled water reuse, groundwater recharge, and historic LA River flows.
- **The Nature Conservancy's Water Supply and Habitat Resiliency for a Future LA River Report** - The Nature Conservancy (TNC) conducted a study to understand the flow characteristics of the LA River based on the changes in the watershed hydrology. The study of the Elysian Valley included an in-depth analysis of biotic conditions of the LA River and a historical ecology investigation of the Elysian Valley and a review of historical and existing hydrological and hydraulic conditions. The Executive Summary of the 2016 TNC report is included in Appendix F of this Summary Report. The analysis conducted in this report compares the results of set of water management scenarios and their effect on species, biodiversity, and habitat resiliency.

The list of studies and project summarized above show the wide range of functions and benefits the LA River has in the City. The LA River is a prime example of the importance of taking a One Water approach when managing the City's water resources to balance the variety of water needs.

Therefore, the One Water Vision is needed to use the City's existing water resources responsibly and make the City more resilient and sustainable in the future.

FLOWS AND DEMANDS

Chapter 4 presents the estimated flows and demands from current conditions from year 2015 through the planning horizon of year 2040. Like any strategic planning document, the estimated future flows and demands provide an important foundation for the One Water LA 2040 Plan (Plan) as the sizing and timing of some of the recommended projects are based on these forecasts. This Chapter includes potable and recycled water demand forecasts, as well as the estimated future wastewater flows, stormwater flows, flows to the LA River, and ocean discharge volumes. More detailed information on flows and demands is provided in TM 1.2 (Existing Flow Conditions) and TM 2.1 (Future Flow Conditions), which are both included in Volume 8 of this Plan.

Chapter 4 starts with an overview of the City-wide flow balance. Subsequently, the historical flows and demands are described, providing context for the existing flow and demand conditions in Fiscal Year (FY) 2015/2016. Next, the estimated future flow and demand conditions are presented in five-year increments from year 2020 to year 2040. As the hydrologic condition of future planning years is unknown at this time, all future flows and demands are presented for average, normal, and wet conditions. A brief description of the Mass Balance Tool (MBT) developed as part of the Plan is also presented. This tool was utilized for the future portfolio analysis as described in Chapter 6. This Chapter concludes with a summary of all the major demands and flows.

4.1 CITY-WIDE FLOW BALANCE OVERVIEW

Within the One Water paradigm, all of the City's water sources are linked through the urban water cycle. In the urban water cycle, rain becomes stormwater, which infiltrates into the groundwater basin or becomes urban runoff. Groundwater is pumped for use as potable water. Once water is used in homes and businesses, it is discharged as wastewater, before being treated and reused as recycled water. Evapotranspiration of water used for irrigation or released to the environment returns again as rain, completing the urban water cycle. The Plan identifies projects, programs, and policies to enhance the City's urban water cycle to increase water recycling and stormwater capture opportunities and minimize losses to the ocean while reducing reliance on purchased and imported water.

As described in Chapter 3, the City receives potable water from groundwater pumping, imported water through the Los Angeles Aqueduct (LAA), and imported purchased water from Metropolitan Water District of Southern California (MWDSC). After distribution of the potable water by LADWP and collection of wastewater by LASAN, the wastewater is treated at four treatment plants, Donald C. Tillman WRP (DCTWRP), Los Angeles-Glendale WRP (LAGWRP), Hyperion WRP (HWRP), and Terminal Island WRP (TIWRP). Water is reused and distributed by LADWP and other regional partners, with excess effluent released to the ocean and to the Los Angeles River through an operational safety weir. Stormwater is either recharged into the groundwater basin, discharged into the ocean and rivers, or is captured for reuse.

4.2 HISTORICAL FLOWS AND DEMANDS

The following subsection describes the historical system flows and demands, consisting of potable water demands, wastewater flows, recycled water demands, stormwater flows, Los Angeles River flows, and ocean discharges.

4.2.1 Potable Water Demands

Potable water demands have historically been met by three major sources, namely local groundwater, imported water from the LAA, and imported water purchased through MWD from the State Water Project (SWP) and Colorado River Aqueduct (CRA). The historical potable water supply mix used by LADWP to meet the City's demands is shown on Figure 3.3, while the supply mix for 2016 with and without water conservation is shown on Figure 4.1. These figures show that the 2016 "wet water" potable demands were 486,734 AFY, while water conservation is estimated to account for 181,573 AFY, resulting in a total demand of 668,307 AFY. The information also shows that the majority of water supplies in 2016 was purchased from MWD.

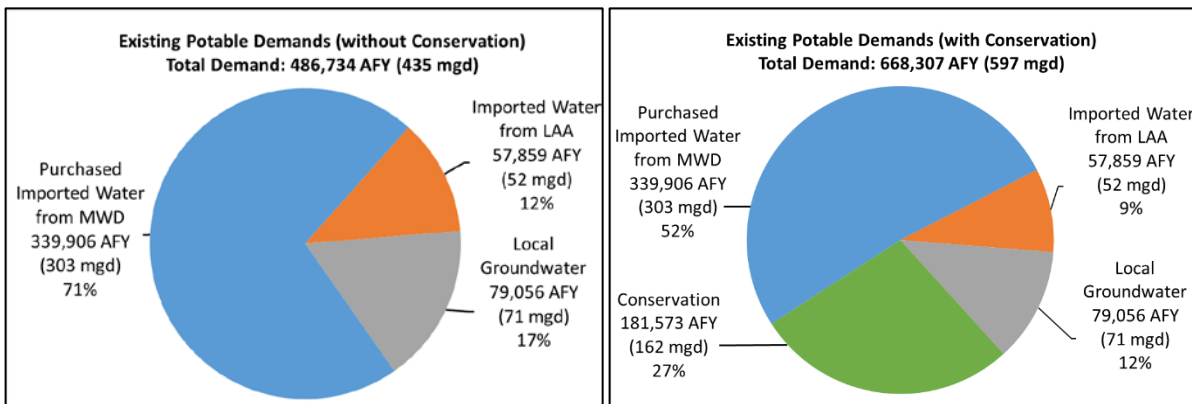

Source: LADWP's 2015 UWMP

Source: LADWP's 2015 UWMP

Figure 4.1 2016 Supply Mix – with and without Water Conservation

The historical water demands since 1985 to 2016 are shown on Figure 4.2. Although the City's population has increased by 1 million people in the past 40 years, the City's water demands have decreased significantly over the past 40 years due to the City's successful water conservation programs such as "Save the Drop," turf rebates, indoor plumbing code changes, and mandatory conservation during severe droughts.

As conservation increases, demand hardening occurs, creating fewer opportunities for future conservation because the high-return low-cost conservation opportunities have already occurred.

Approximately 60 percent of the water demands are indoor use, with the remaining 40 percent outdoor use. The indoor water demands become wastewater flows, which are described in more detail in the next section.

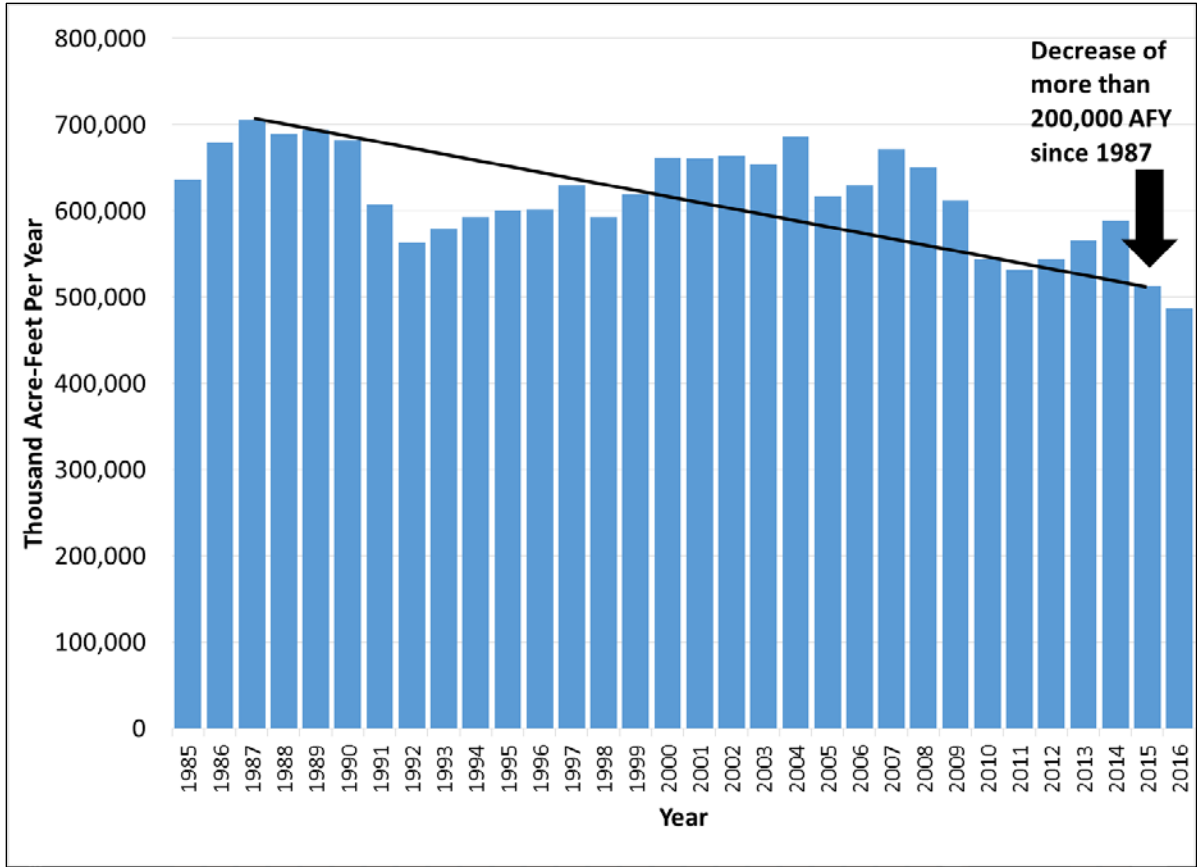

Figure 4.2 Historical Water Demand

4.2.2 Wastewater Flows

Wastewater flows are a combination of the following components:

- Wastewater produced by residential, commercial, and industrial customers within the City.
- Contract Agency Wastewater Flows generated by 29 contracting agencies that make up the cities, unincorporated county, federal, and other jurisdictions outside the boundaries of the City.
- Stormwater Infiltration is rainfall that enters the sewer system directly (inflow) via leaks or holes or indirectly (infiltration) through soil saturation and migration of water. This wastewater flow component is also referred to as rainfall-dependent inflow and infiltration (RDI/I).
- Dry Weather Runoff is the captured surface runoff that is pumped into the wastewater collection system via low-flow diversion structures.

Figure 4.3 shows existing wastewater flows by source for 2015. Contract agency flows equal 15 percent of the total flows. Dry weather runoff and stormwater infiltration combined total less than 3 percent of total flows. The remaining 82 percent is the City base sewer flows.

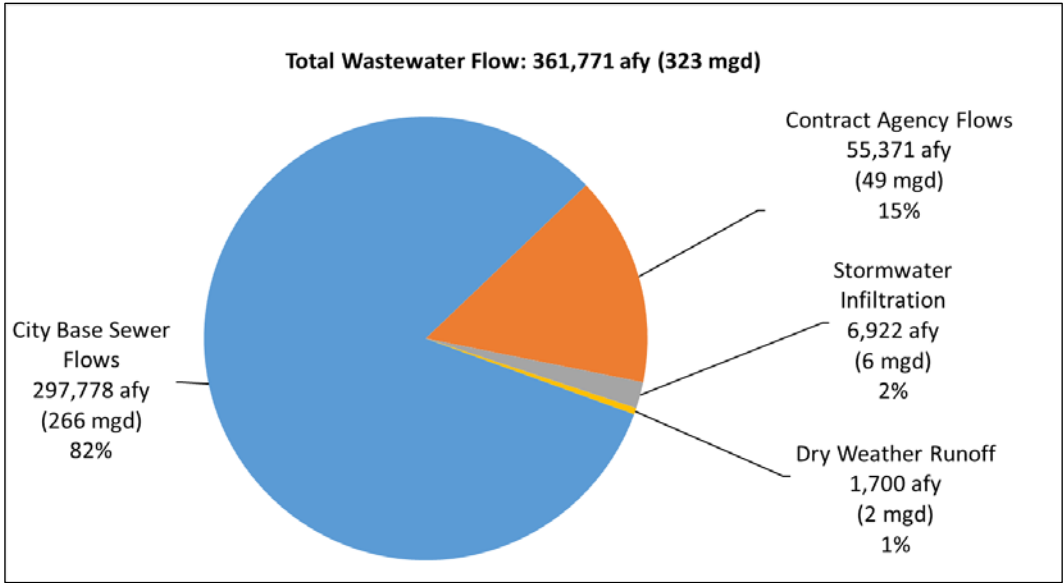

Figure 4.3 Existing Wastewater Generated by Source (2015)

Figure 4.4 shows existing wastewater flows by each of the City's four water reclamation plants. Over 75 percent of the flows are treated at Hyperion Water Reclamation Plant (HWRP). The City has the ability to bypass flows (also called return flows) from Donald C. Tillman Water Reclamation Plant (DCTWRP) and Los Angeles-Glendale Water Reclamation Plant (LAGWRP) to HWRP, rather than treating the flows at the upstream water reclamation plants (WRP). In 2015, the bypass flows averaged 16 million gallons per day (mgd) from DCTWRP and 3 mgd from LAGWRP.

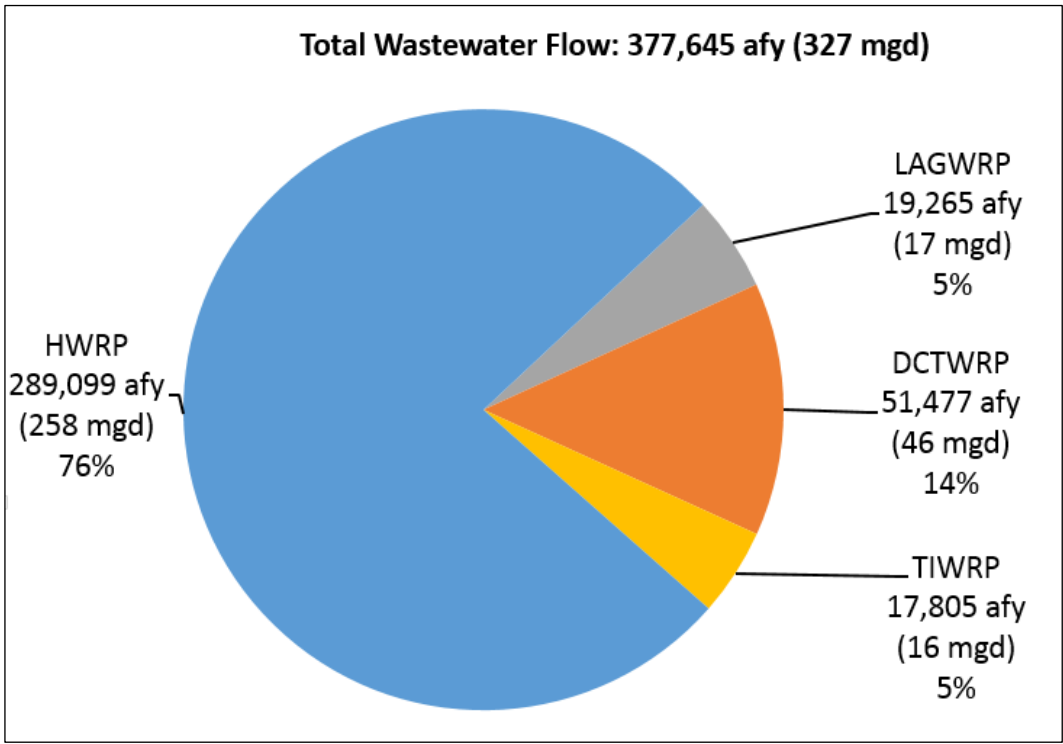

Figure 4.4 Existing Wastewater Influent Flows by Plant (2015)

Figure 4.5 shows existing average dry weather flows (ADWF) and peak wet weather flows (PWWF) at each of the City's four WRPs in 2015. As shown, the PWWF are as high as three times ADWF.

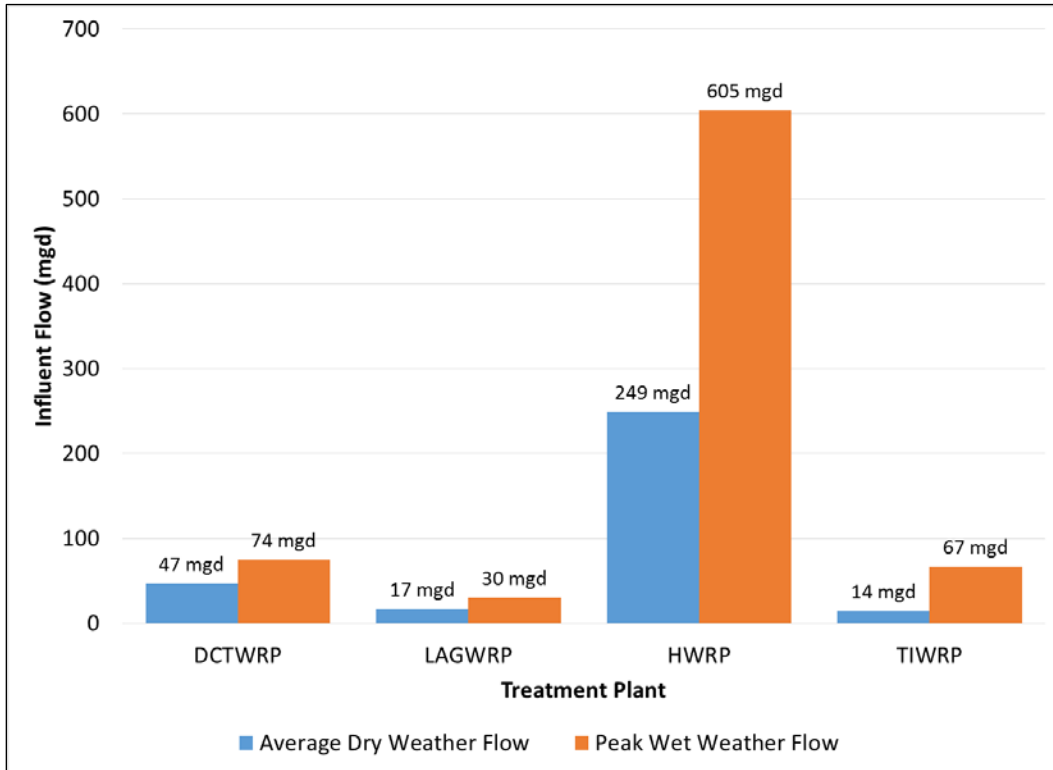

Figure 4.5 Range in Dry and Wet Weather Wastewater Flows (2007-2016)

4.2.3 Recycled Water

A portion of the wastewater that is treated at the four water reclamation plants is recycled for a variety of non-potable water uses. These recycled water demands currently include the following uses:

- **Additional Water Beneficially Reused** – Flows from DCTWRP are beneficially used at the Japanese Gardens, Lake Balboa, and Wildlife Reserve.
- **Non-Potable Reuse Such as Irrigation and Industrial Use** – A portion of flows from all four WRPs are used for non-potable use. The City of Glendale has the rights to half of the flow from LAGWRP.
- **Secondary Effluent that is sold for Further Treatment and Reuse** – A portion of the flows from HWRP are sold to West Basin Municipal Water District (WBMWD), which treats the water at the Edward C. Little Water Recycling Facility (ELWRF) and uses the water for non-potable irrigation and industrial use as well as seawater intrusion barrier injection.

The existing recycled water demands are approximately 75,000 AFY and are shown on Figure 4.6. Compared to a total dry weather wastewater flow of 310 mgd (347,000 AFY), approximately 22 percent of the wastewater was recycled in 2016.

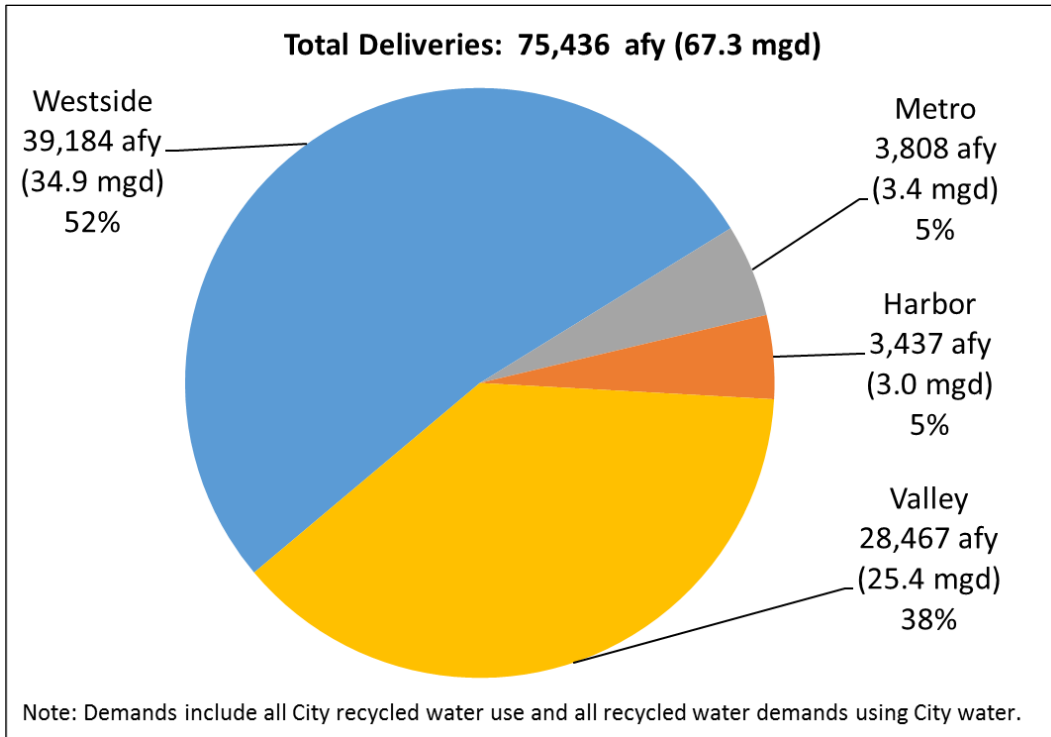

Figure 4.6 Existing Recycled Water Demands by Service Area (2016)

The City's four WRPs currently produce recycled water, as shown on Figure 4.7. These four WRPs are as follows:

- DCTWRP produces disinfected tertiary recycled water. In fiscal year (FY) 2015-16, DCTWRP treated a total of 34,200 AFY (31 mgd) of influent sewage, resulting in a recycled water production of 31,400 AFY (28 mgd). Currently, most of this recycled water is put to beneficial use via the flow-through lakes at DCTWRP (Lake Balboa, the Japanese Garden, and the Wildlife Lake), prior to discharge into the Pacific Ocean via the Los Angeles River.
- LAGWRP produces disinfected tertiary recycled water. In FY 2015-16, LAG treated a total of 15,200 AFY (14 mgd) of influent sewage, of which only 3,800 AFY (3.4 mgd) of recycled water was utilized. Of this total, 50 percent is allocated to the City of Los Angeles, and 50 percent is allocated to the City of Glendale. Flows that are not utilized for recycled water use are discharged to the ocean via the Los Angeles River.
- HWRP produces secondary effluent, a portion of which is further treated for reuse by WBMWD. In FY 2015-16, HWRP treated a total of 279,000 AFY (249 mgd) of influent sewage, of which 38,300 AFY (34 mgd) was purchased by WBMWD for reuse for non-potable uses and the West Coast Seawater Intrusion Barrier. Currently, most of the plant effluent is discharged to the ocean.
- TIWRP produces advanced treated recycled water. In FY 2015-16, TIWRP treated a total of 16,100 AFY (14 mgd) of influent sewage, of which 3,400 AFY (3 mgd) of recycled water was utilized at the Dominguez Gap Seawater Intrusion Barrier. Since the completion of upgrades to TIWRP in 2017, all of the flows become advanced treated recycled water and can be utilized for beneficial use.

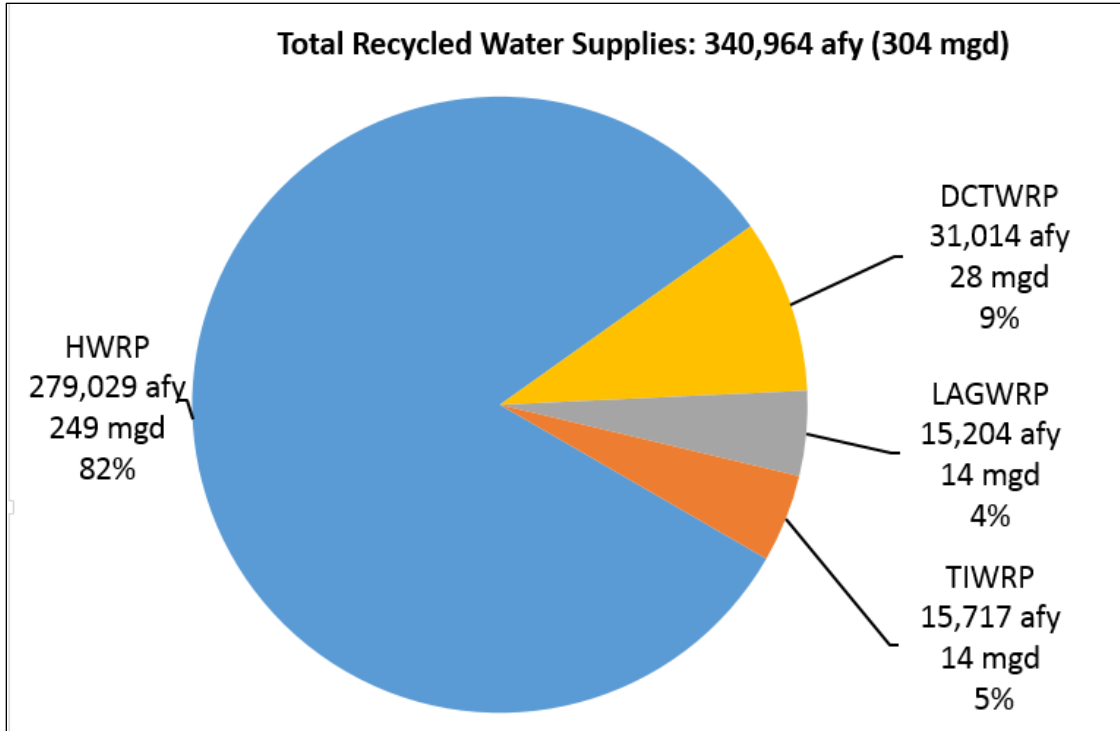

Figure 4.7 Existing Recycled Water Supplies by Plant (2016)

The total use of recycled water from the City's four WRPs is summarized in Table 4.1 (see TM 1.2, Volume 8, for details and assumptions). As shown, the City's recycled water combined demand for irrigation and other beneficial uses is approximately 35,100 AFY. The City of Glendale's demand is approximately 1,600 AFY. WBMWD purchased approximately 38,300 AFY of recycled water for customer demand and injection.

Treatment Plant	City's Demand (AFY)	Glendale's Demand (AFY)	WBMWD's Demand (AFY)	Other Beneficial Use (AFY)	Total Demand (AFY)
DCTWRP	3,289	0	0	25,178	28,467
LAGWRP	2,308	1,557	0	0	3,808
HWRP	879	0	38,305	0	39,184
TIWRP	3,437	0	0	0	3,437
Total	9,913	1,557	38,305	25,178	74,896

4.2.4 Stormwater

Stormwater is an important supply source, as it contributes to the local groundwater storage through groundwater recharge. Additionally, stormwater conveys a variety of urban pollutants and needs to be captured and treated to meet water quality requirements. The following three main sources that contribute to the total amount of stormwater flow in the City are:

- Precipitation: Rainfall or precipitation that falls over the City.
- Run-on: Runoff water from portions of the watersheds upstream of the City.
- Excess Irrigation (also referred to as dry weather runoff): Water utilized for irrigation applied within the City that reaches the storm drain system.

These sources of stormwater are shown on Figure 4.8. Approximately half of the stormwater comes from precipitation, 30 percent from excess irrigation (dry weather runoff), and the remaining 20 percent from run-on.

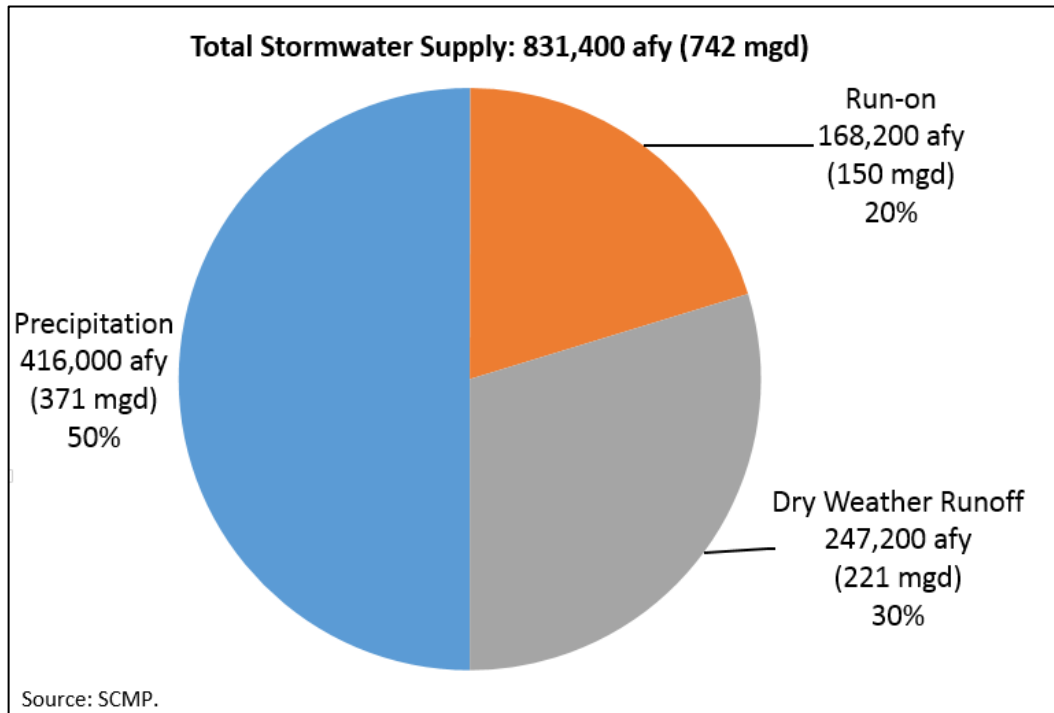
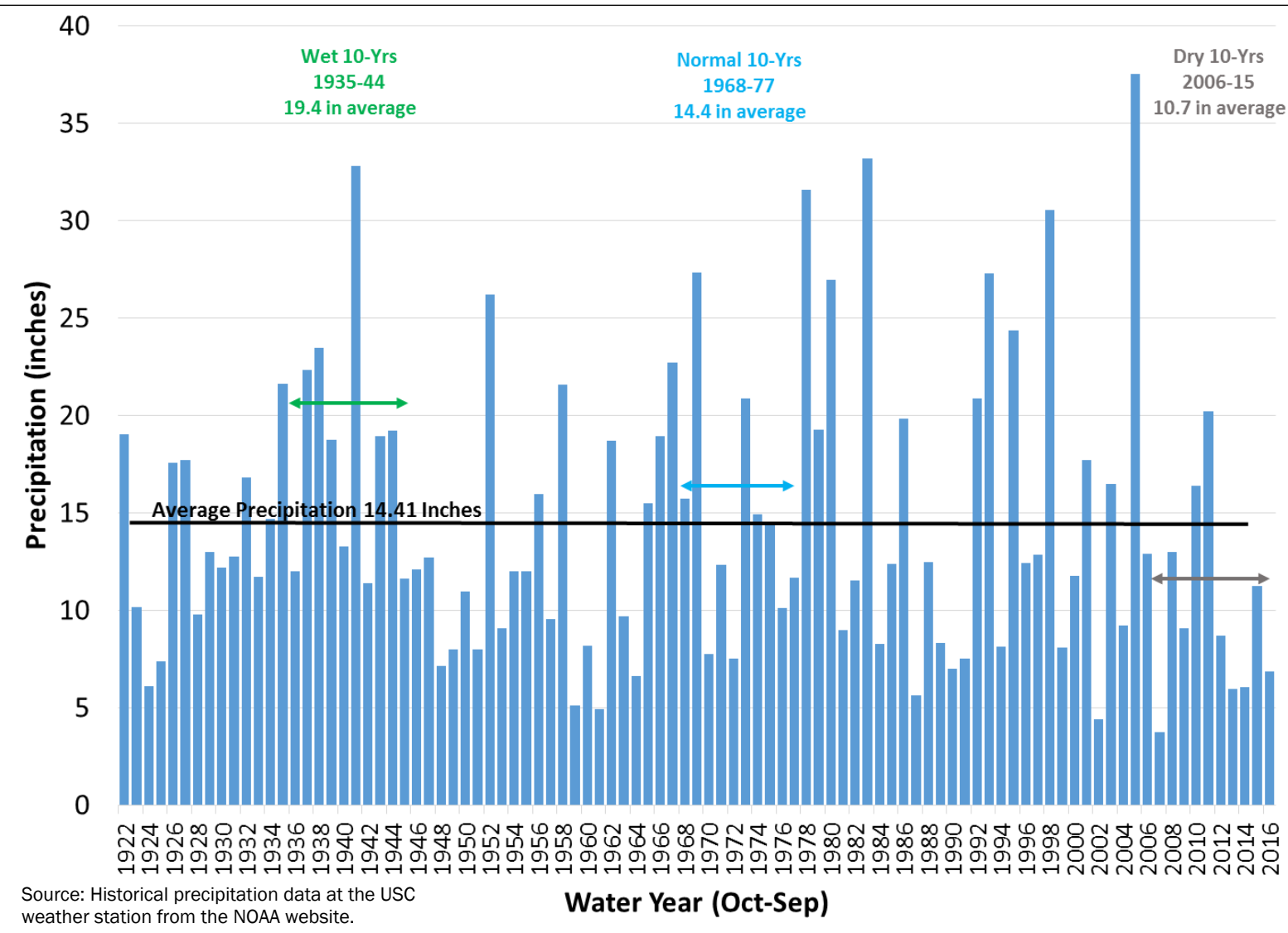

Figure 4.8 Existing Stormwater Supplies (2016)

As shown on Figure 4.8, precipitation is the primary source of the City's stormwater flows. Naturally, precipitation varies greatly from year to year based on hydrologic conditions. As shown on Figure 4.9, the City's annual precipitation has varied from roughly 4 to 37 inches. Figure 4.9 also shows wet-, normal-, and dry-year sequences based on historical hydrology. It is important to note that the past 20 years have been significantly drier than previous periods; these dry trends have triggered conservation mandates and the City's goals to increase local water supplies.



Source: Historical precipitation data at the USC weather station from the NOAA website.

Figure 4.9 Historical Precipitation from 1922 to 2016

Figure 4.10 presents a breakdown of stormwater flows, as well as typical normal, wet, and dry years. However, the relatively small amount of capture and direct use is not visible due to the scale of this chart. It should be noted that the average annual stormwater flows used in the Mass Balance Tool include stormwater recharge at the LA County spreading basins in the San Fernando Valley. During discussions with the City it was determined to account for the LA County stormwater recharge as part of the future integration opportunities analysis, which is reflected in the values shown on Figure 4.10. However, the stormwater flows presented in Volume 3 Stormwater and Urban Runoff Facilities Plan only reflect the existing and potential recharge activities within the City of Los Angeles boundary.

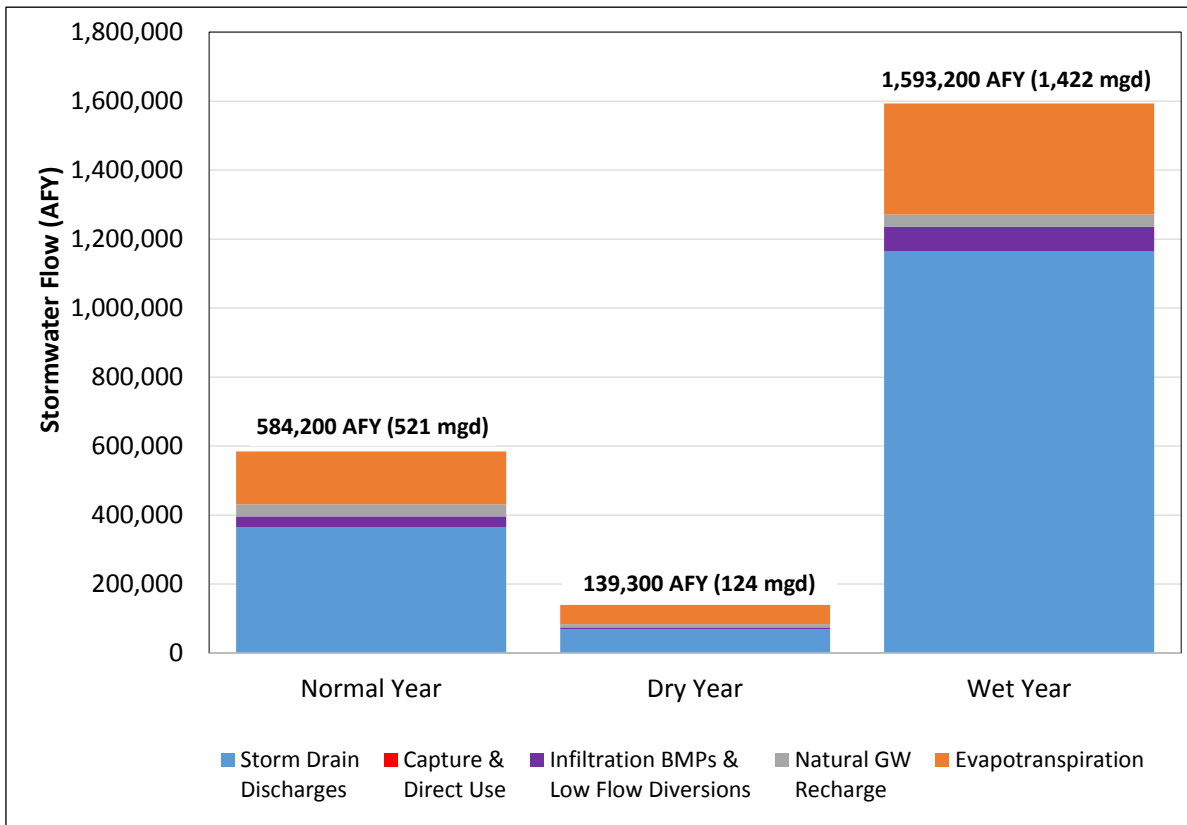

Figure 4.10 Typical Stormwater Flows

The stormwater inflows ultimately contribute to the following stormwater flow components:

- **Storm Drain Discharges to Rivers and Oceans** – Stormwater flows that discharge into rivers and the ocean.
- **Capture and Direct Use** – Stormwater flows that are captured and used directly.
- **Stormwater Infiltration Best Management Practices (BMP)** – Stormwater that is infiltrated into groundwater basins via stormwater capture facilities.
- **Natural Groundwater Recharge** – Stormwater that passively infiltrates into the ground through permeable surfaces.
- **Evapotranspiration and Other Losses** – Stormwater that is used by plants or evaporated directly or infiltrated into perched aquifers or aquifers not usable by the City.

Stormwater volumes are presented by four major watersheds: Upper Los Angeles River Area, Ballona Creek, Dominguez Channel, and Santa Monica Bay/Marina del Rey.

Stormwater management has the following three goals:

- **Water Quality Improvement** – These projects improve the health of local watersheds by reducing impervious cover, restoring ecosystems, decreasing pollutants in the waterways, and providing environmental and habitat benefits. Stormwater improvement projects intended to improve the quality of a downstream waterbody are typically driven by regulations such as TMDLs and/or 303(d) listings.
- **Water Supply Augmentation** – These projects capture runoff to help offset potable water use through direct use projects. They also increase water supply through groundwater augmentation and capture and use wet-weather/dry-weather runoff to offset potable water demand and/or enhance environmental and habitat conditions.
- **Flood Risk Mitigation** – These projects protect life and safety and mitigate local flood impacts. Stormwater improvement projects intended to reduce flood risks are typically driven by asset-specific needs, such as whether an asset is located near a known or anticipated area of flooding; insufficient capacity; asset deterioration or expiration of useful life based on age; and known or anticipated impacts from sea level or groundwater rise.

4.2.5 River and Ocean Flows

The majority of stormwater and wastewater effluent flows end up in rivers and oceans. As shown on Figure 4.11, stormwater flows to the LA River accounts for the majority (56 percent) of flows, while the remaining 44 percent includes stormwater flow to Ballona Creek and other creeks, and other discharges into the LA River.

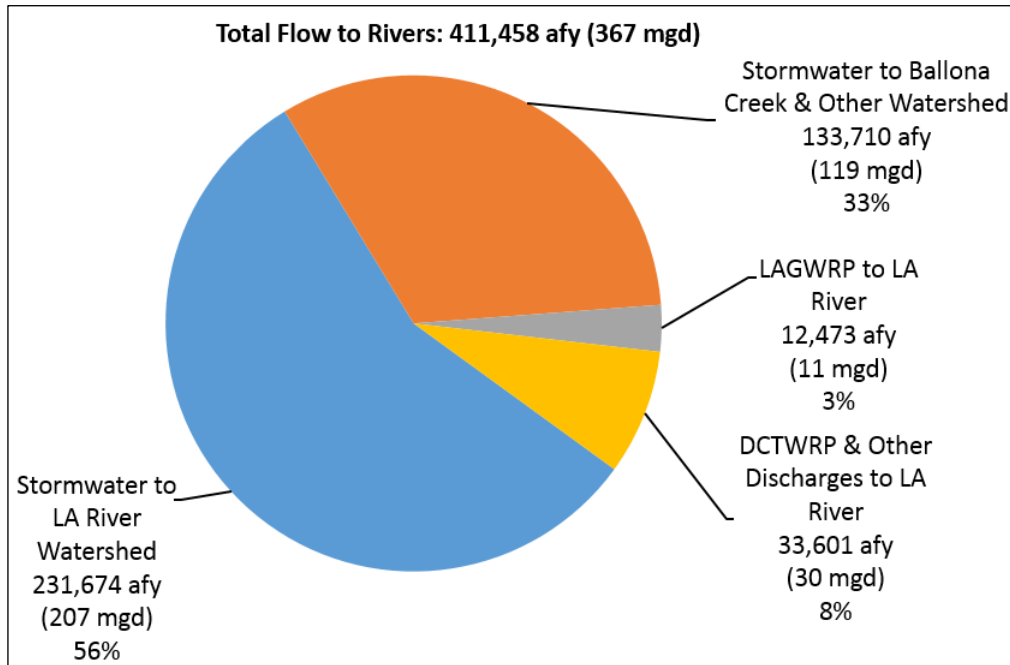

Figure 4.11 Existing Sources of Flows to Rivers (Normal Year)

Flows to the ocean are shown on Figure 4.12. The primary flow sources to the ocean are Los Angeles River, Ballona Creek, and HWRP.

It should be noted that the flows presented are annual averages and include storm events in all years; they are not reflective of dry- or wet-weather flow days. Flows in the Los Angeles River are presented in more detail in the Los Angeles River Flow Study (see Volume 4) as well as many other ongoing studies, such as studies by UCLA and The Nature Conservancy (TNC). Flow information on river flows and ocean discharges can also be found in TM 1.2 and TM 2.1 (see Volume 8) and the Stormwater Facilities Plan (see Volume 3).

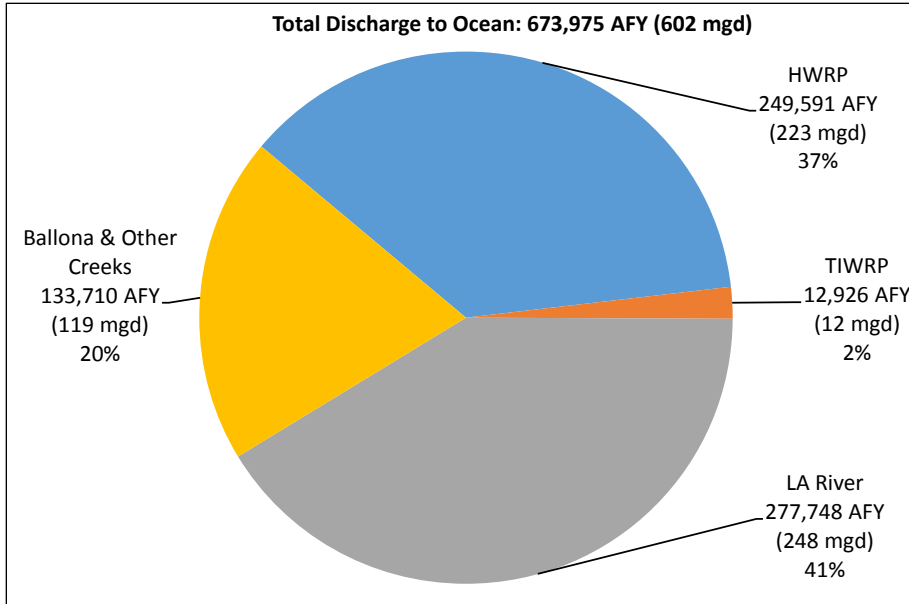

Figure 4.12 Existing Sources of Flows to Ocean (Normal Year)

4.3 FUTURE FLOWS AND DEMANDS

The following subsection describes the projected future system flows and demands, consisting of potable water demands, wastewater flows, recycled water demands, stormwater flows, Los Angeles River flows, and ocean discharges.

4.3.1 Key Assumptions, Targets, and Goals

The projected water demands and baseline supply mix through year 2040 are based on the LADWP 2015 Urban Water Management (UWMP). These future flows include the implementation of the Existing Water Management Strategies discussed in Chapter 3 of this report, but do not include the effects of projects discussed in Chapters 5 through 8 of this report.

The water supply targets are based on the Mayor's Sustainable City pLAN (pLAN), which include:

- Reducing imported water purchases by 50 percent by 2025
- Sourcing 50 percent of water locally by 2035
- Capturing 150,000 AFY of storm water by 2035
- Reducing average per capita water use by 22.5 percent by 2025
- Reducing average per capita water use by 25 percent by 2035

The following assumptions were used in developing the future flow projections:

- The hydrology for years 2001, 2005, and 2007 are used as representative hydrology for stormwater flows. These three years represent a typical normal (2001), wet (2005), and dry (2007) year.
- Assumptions for normal and dry year conditions for potable water, wastewater, and recycled water were used from the 2015 UWMP.

Additional important flow and demand goals include:

- No effluent discharge from Terminal Island Water Reclamation Plant (TIWRP)
- Stormwater total maximum daily load (TMDL) compliance

4.3.2 Potable Water

A summary of the total projected 2040 potable water supply mix under normal-, wet-, and dry-year hydrologic conditions is compared on Figure 4.13. The potable water demand targets for normal- and dry-year hydrologic conditions are based on the 2015 UWMP and vary based on the hydrologic condition—equal to 621,000 AFY under a normal year and 654,800 AFY in a dry year with conservation. Wet-year supplies needed are expected to be lower, at 590,500 AFY. Indoor demands do not change based on hydrology, but outdoor demands vary based on the hydrology.

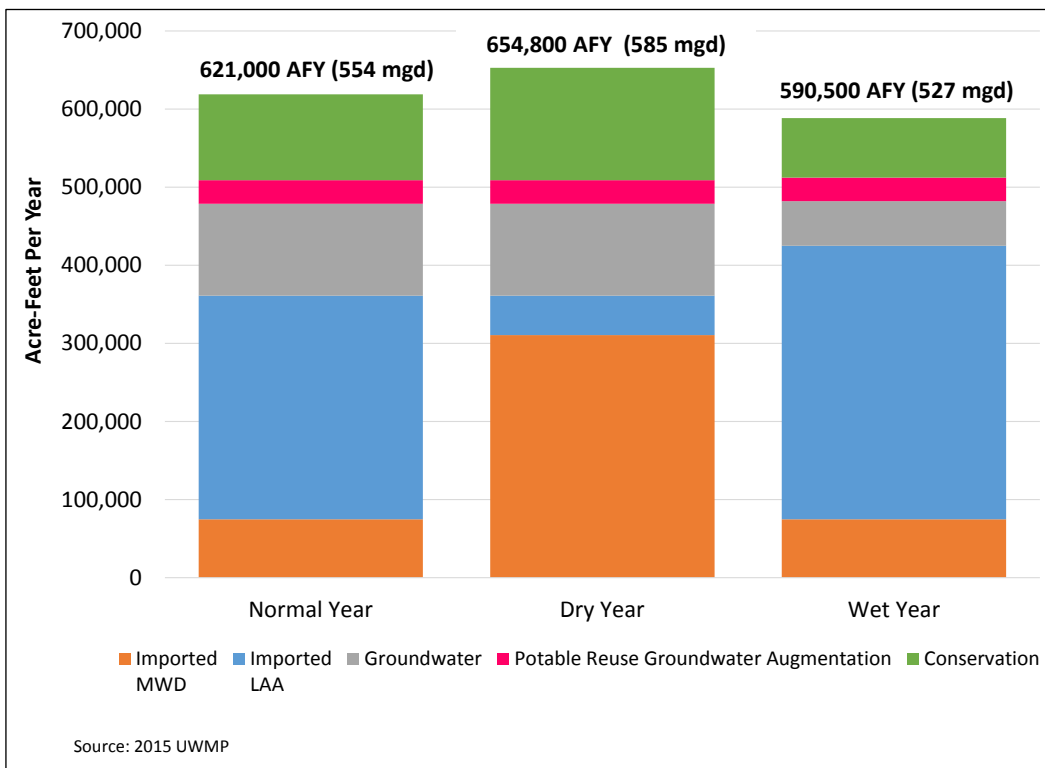

Figure 4.13 Projected Supply Mix for Year 2040

The largest difference in water supply sources between wet, normal, and dry years is the amount of imported water purchased from MWDSC and flows from the LAA. In wet years, there will be significant flows from LAA, leading to minimal amounts of imported water purchased from MWDSC. In dry years, the flows from LAA will be minimal, leading to significant amounts of imported water purchased from MWDSC.

4.3.3 Wastewater

Projected wastewater flows are based on the indoor portion of the projected water demands, which are assumed to remain as 60 percent of the City's normal year potable water demand throughout the planning period, as presented above. Additionally, the following wastewater flow components were assumed to remain relatively constant compared to existing flow conditions:

- Contract agency wastewater flows
- Inflow
- Stormwater infiltration

The wastewater flow forecast is shown on Figure 4.14. Wastewater flows are expected to increase by 6 percent by 2040, which equates to 20,600 AFY (19 mgd). This forecast could vary depending on water conservation, growth, and changes in flows from the City's 24 contracting agencies.

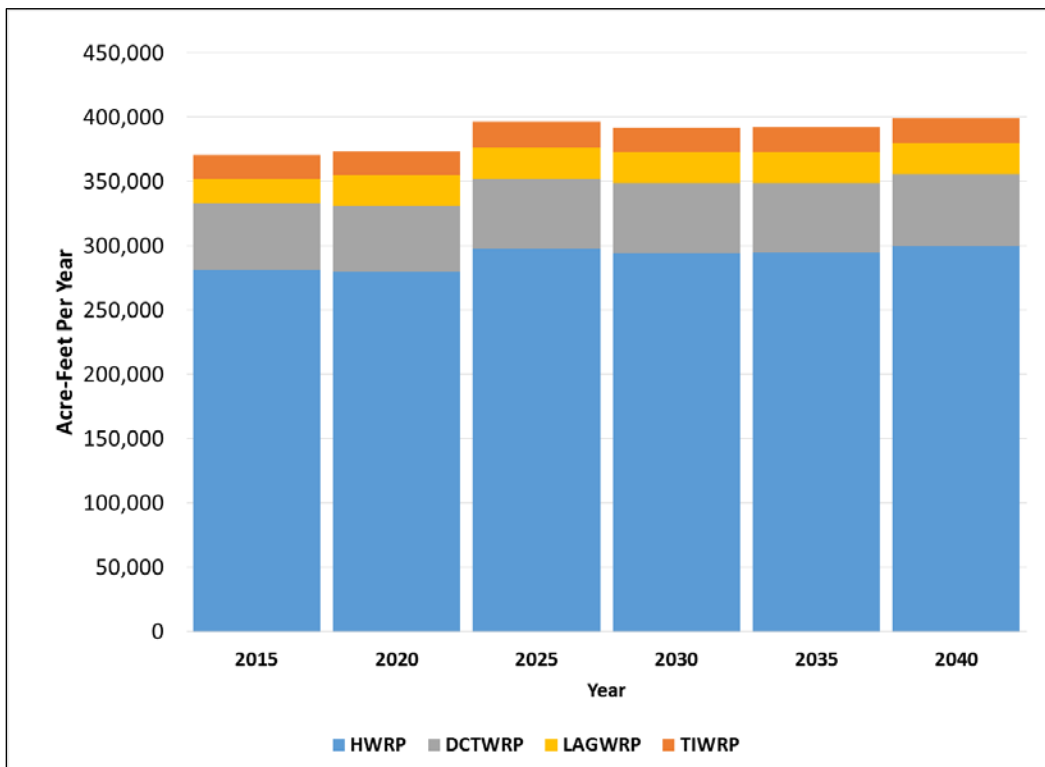

Figure 4.14 Baseline Wastewater Forecast

4.3.4 Recycled Water

Recycled water demands are calculated using the projected wastewater flows from a combination of the City customer's indoor water demands, contract agency flows, and stormwater infiltration. Recycled water supplies are the effluent from the City's WRPs, which is calculated as the influent flows minus treatment plant losses and bypass flows to other WRPs.

The projected recycled water demands shown on Figure 4.15 are based on the following key assumptions:

- The projected recycled water customers for year 2040 were obtained from LADWP's 2015 UWMP as well as the Annual Recycled Water Report for FY 2014/15. Phasing of demands was assumed to be implemented based on the 2015 UWMP.
- The other beneficial uses supplied from DCTWRP were assumed to remain constant from existing conditions, while deliveries to Machado Lake were assumed to start in 2017.
- TIWRP was upgraded in 2017 so that all the water can be used for recycling and no water will be discharged to the ocean.
- Recycled water from HWRP to LAX to Scattergood (first phase of 1.5 mgd) will be used starting 2020.
- The groundwater replenishment project in San Fernando Basin (up to 30,000 AFY) supplied from DCTWRP was assumed to be realized in 2023.
- Based on ongoing/recent negotiations, deliveries to West Basin Municipal Water District (WBMWD) will be increased to as much as 70 mgd as of year 2020 and kept constant through year 2040.
- There are also plans to build a large-scale membrane bioreactor (MBR) at HWRP to improve water quality so that more water can be used for recycling.

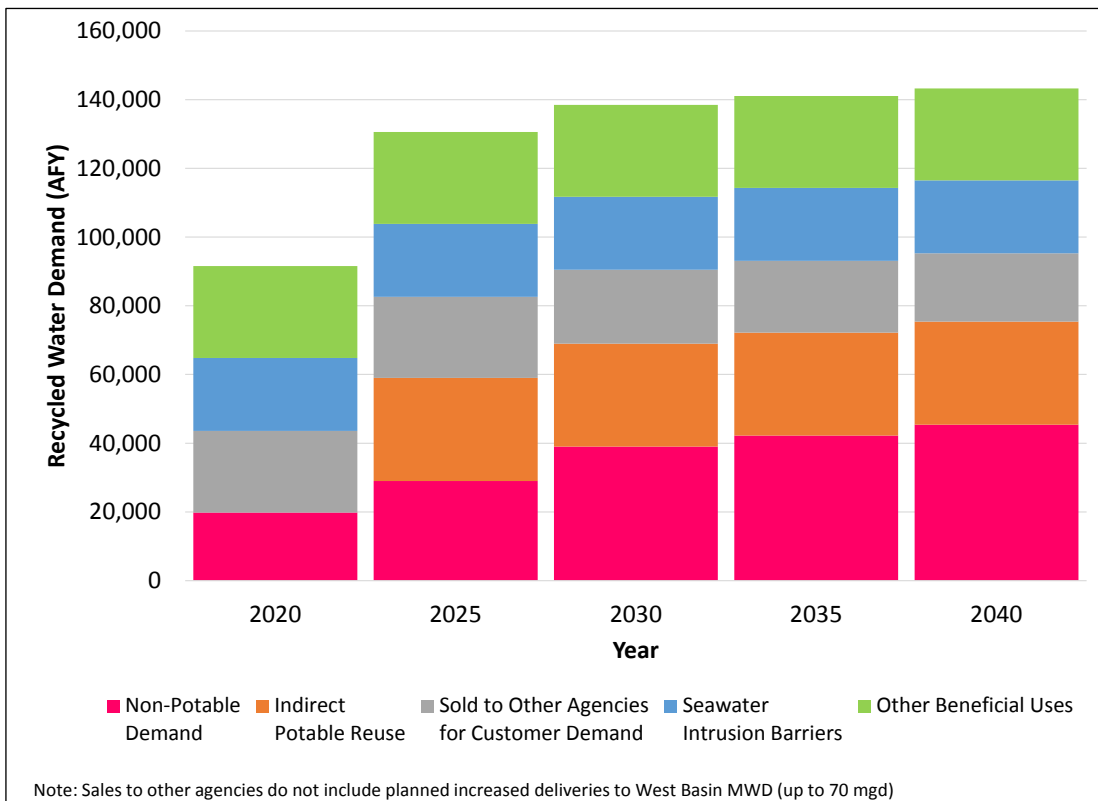

Figure 4.15 Recycled Water Demand Forecast

A comparison of the projected recycled water demands and supplies for year 2040 by WRP is shown on Figure 4.16.

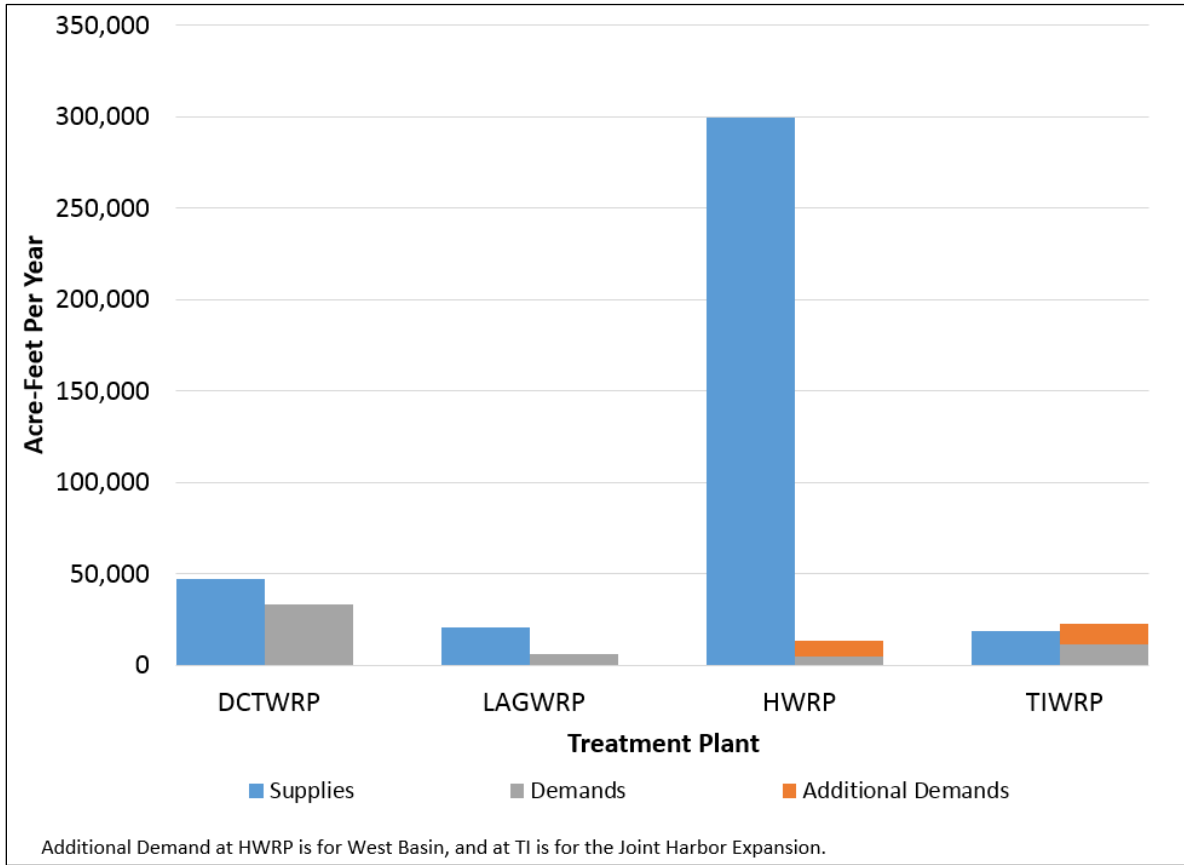

Figure 4.16 Projected Recycled Water Supplies and Demands (2040)

4.3.5 Stormwater

Key assumptions used in the projection of future stormwater flows include:

- Average annual stormwater inflows (precipitation, irrigation, and run-on from upstream) in normal, dry, and wet years do not change over the next 25 years.
- Capture volumes that benefit groundwater and water supplies are based on projects defined in the Stormwater Capture Master Plan (SCMP) and the Enhanced Water Management Plans (EWMPs). SCMP projects total an additional 86,200 AFY of stormwater capture as a water supply benefit, recharging the water into the groundwater basins, counting both City and Los Angeles County projects. EWMP projects total an additional 77,300 AFY of stormwater management. Some of the projects covered in SCMP and EWMPs overlap; therefore, the total capture volume is not the sum of the two categories of projects. Details for this number are discussed in TM 2.1 (Volume 8).
- Water Year 2005 is representative of a typical wet year, and Water Year 2007 is representative of a typical dry year. No adjustment was made for the effects of potential climate change.

- All water infiltrated by stormwater BMPs in areas conducive to groundwater recharge contributes to groundwater recharge. Not all groundwater recharge, however, has a water supply benefit, as only locations where the watershed overlays a usable groundwater basin creates a water supply benefit.
- The land use in the City is anticipated to remain approximately the same as the existing condition over the next 25 years, although the fraction of impervious areas is expected to change over time from stormwater infiltration BMPs and effects of the City’s LID ordinance.

A summary of stormwater flows under normal-, dry-, and wet-year conditions for year 2040 are presented on Figure 4.17. Compared to existing conditions, stormwater BMP implementation and low-flow diversions are expected to increase flows from 29,000 AFY to 110,000 AFY in a normal year, almost a four-fold increase.

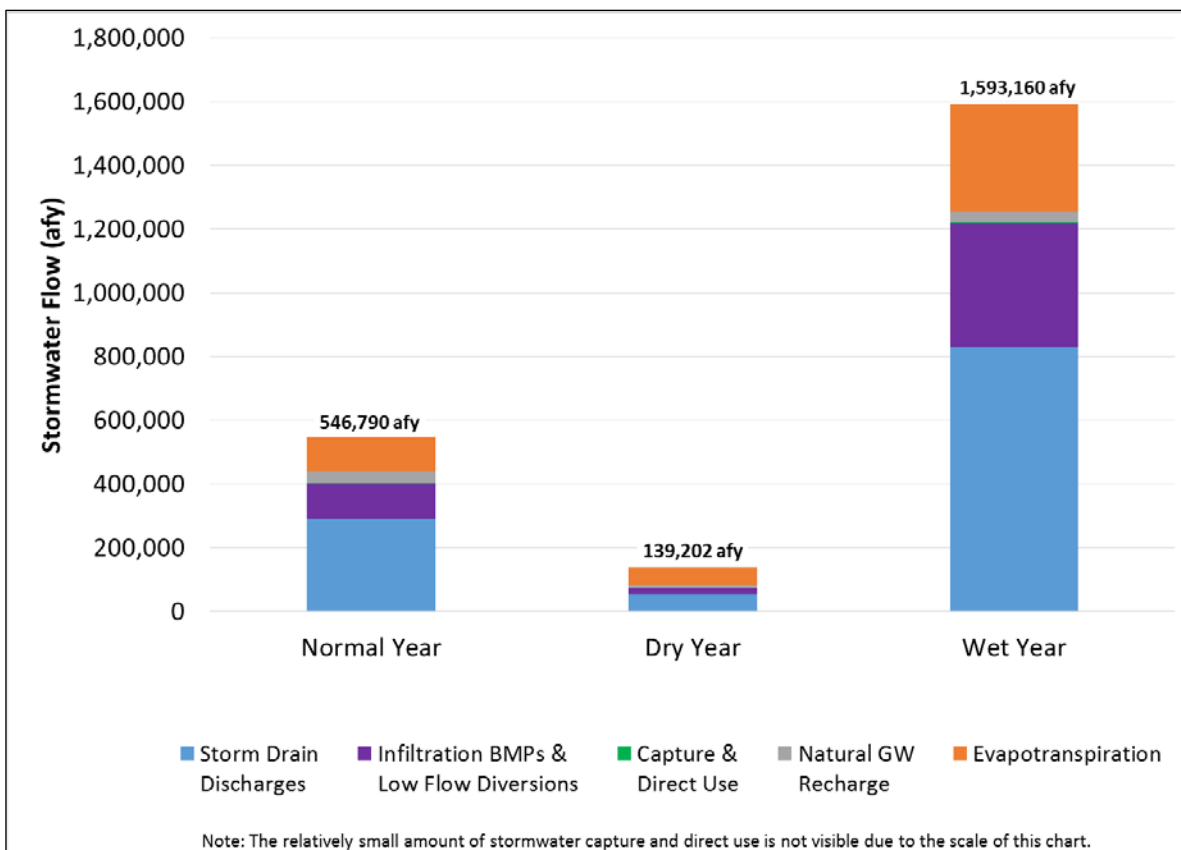

Figure 4.17 Stormwater Flow Estimates

4.3.6 River and Ocean Flows

One of the goals of this Plan is to reduce losses to the ocean and maximize recycle, capture, and reuse of stormwater and wastewater flows.

Future flows in the Los Angeles River may be affected by future water management strategies, such as projects to infiltrate stormwater flows, decrease dry-weather runoff, increase reuse wastewater effluent from LAGWRP or DCTWRP that is currently discharged to the river, and capture river flows for water supply or recreational needs. Potential future water management strategies described in Chapter 6 of this report could also modify the Los Angeles River flows. The impacts of the future water management strategies to the Los Angeles River have not been quantified.

Ocean discharges would be also reduced due to increased water recycling at all of the City's WRPs as discussed in Section 4.3.4 and due to stormwater management projects as discussed in Section 4.3.5. The projected reduction in ocean discharges compared to existing conditions using the baseline demand and flow assumptions is presented on Figure 4.18.

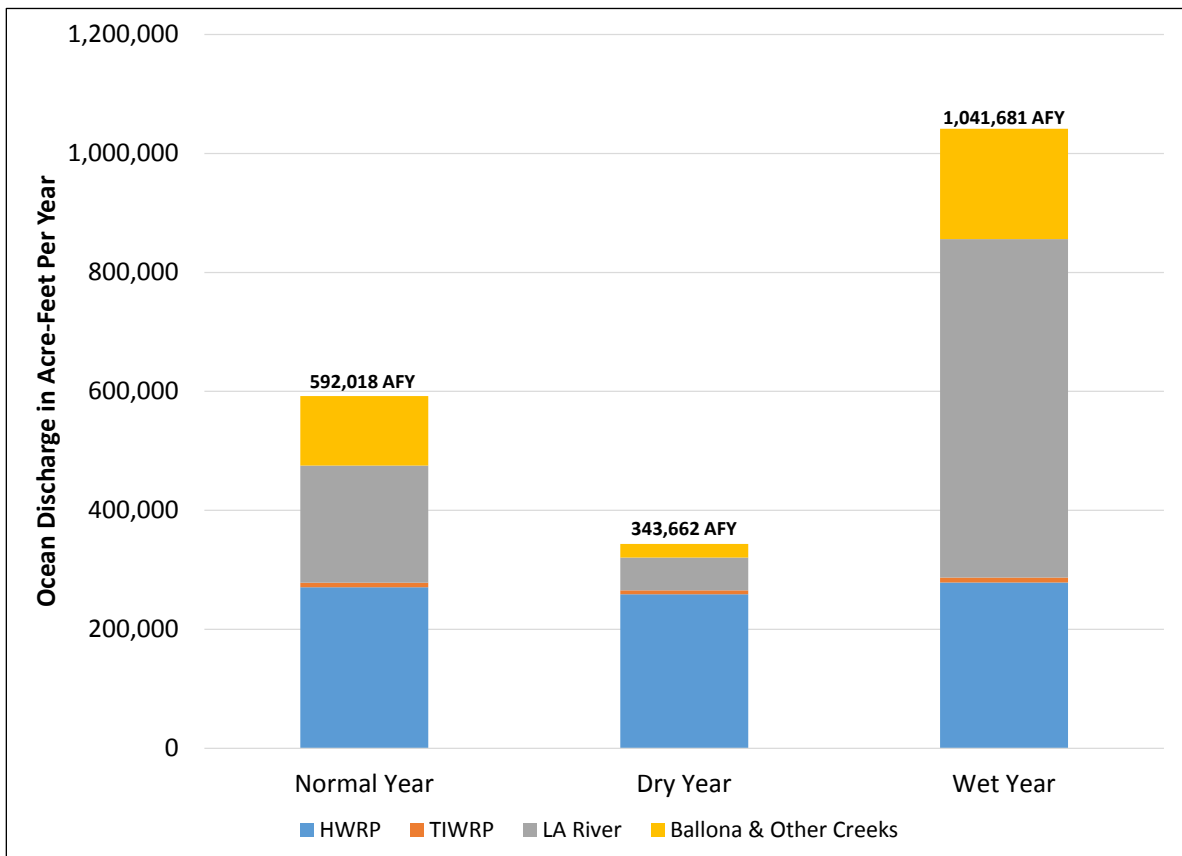

Figure 4.18 Projected Ocean Discharges

4.4 MASS BALANCE TOOL

The urban water cycle is getting even more complex with the new water recycling opportunities, focus on stormwater, and aggressive goals from the Mayor in the Sustainable City pLAN. To track all these developments and inter-relationships on water flows and demands, a comprehensive, proprietary MBT was developed, called the Blue Plan-it® (BPI) Model.

The purpose of the water mass balance tool is to quantify all major water flows throughout the City. This tool was used to access flow data for both existing and future conditions in one-year increments for any period between 2015 and 2040. Due to the large impact of annual rainfall on the overall water balance, the tool was designed to calculate the flow balance for three typical hydrologic conditions, namely typical normal, wet, and dry years. The map view and user dashboard of the mass balance tool are shown on Figure 4.19 and Figure 4.20, respectively.

The development of the City-wide mass balance tool involved the following four steps:

- Model design and development
- Data gathering and input
- Model calibration and validation
- Model customization for analysis

When a simulation is run on the tool, the tool provides estimated flows for potable water, wastewater, recycled water, stormwater, river flows, and ocean discharges; a summary of the major flows and demands is shown on Figure 4.21. The tool also provides estimated capital and unit costs for various combinations of projects and hydrologic conditions. The tool was used to evaluate a wide range of long-term concept options in the portfolio evaluation (see Chapter 6). Details on the Mass Balance Tool can be found in TM 1.2 and TM 2.1 (see Volume 8).

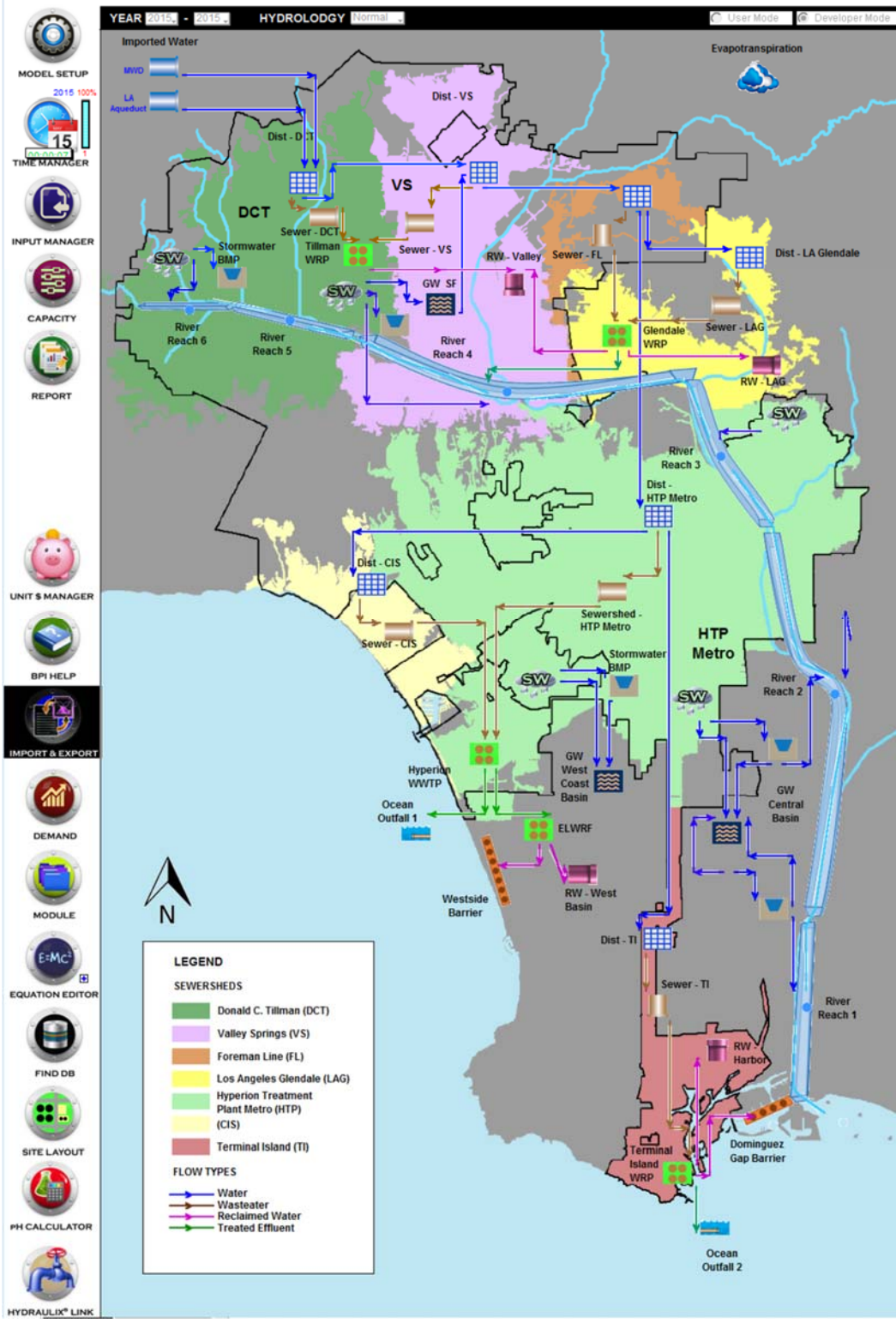

Figure 4.19 - Mass Balance Tool – Map View
One Water LA 2040 Plan
Summary Report

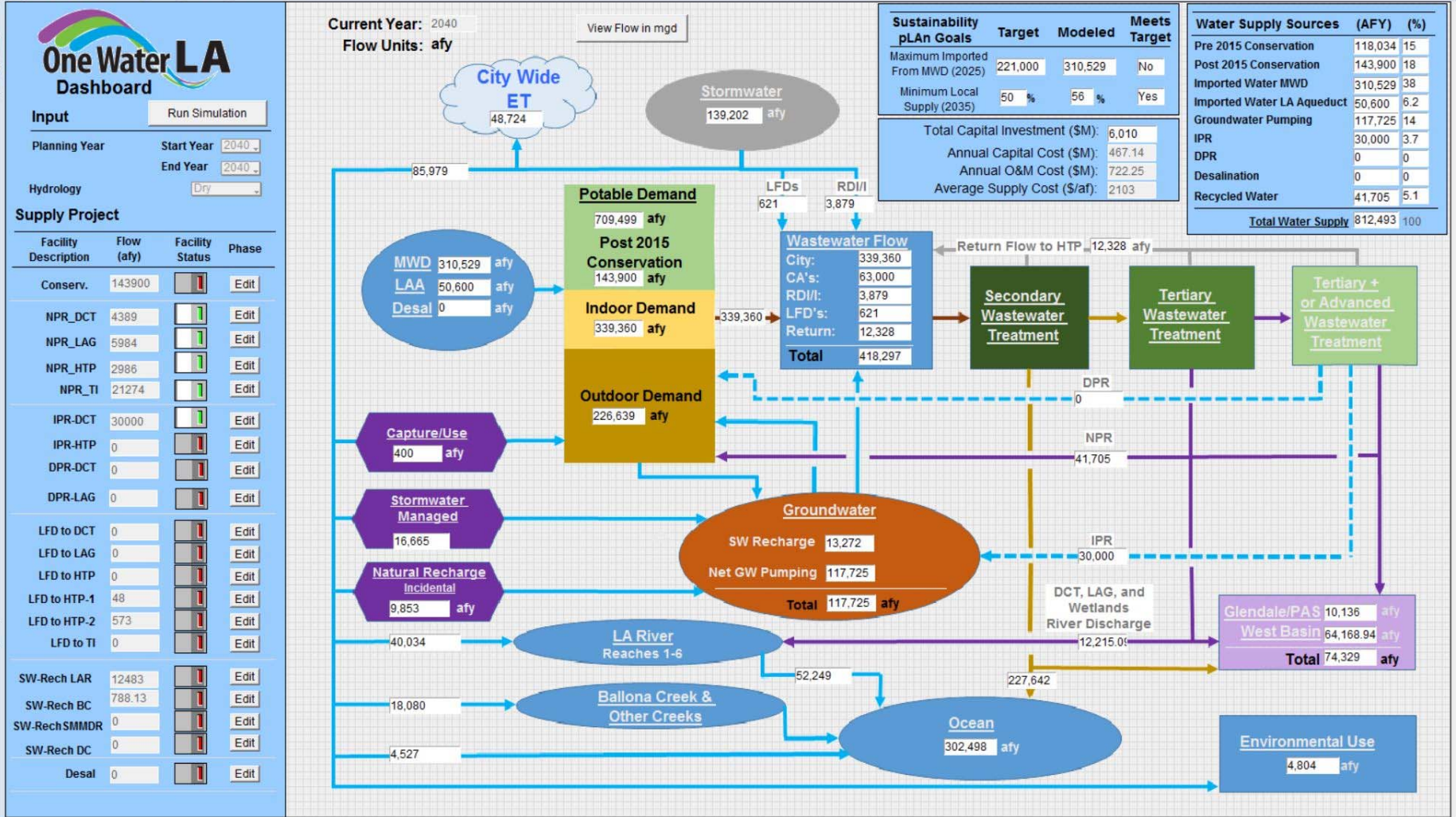

Figure 4.20 - Mass Balance Tool – User Dashboard View
 One Water LA 2040 Plan
 Summary Report

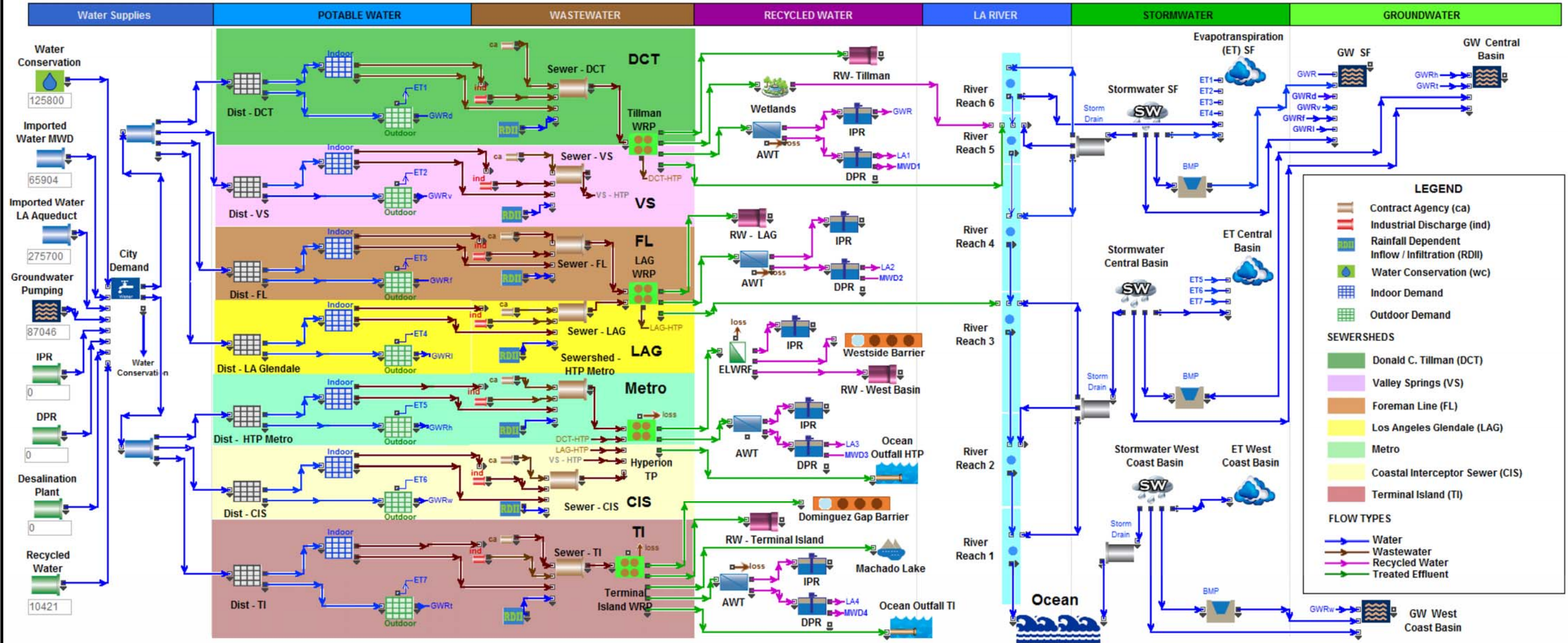

Figure 4.21 - One Water Diagram of Major Flows and Demands
One Water LA 2040 Plan
Summary Report

4.5 FLOW BALANCE SUMMARY

The existing flow summary, described in TM 1.2 (Volume 8) is shown on Table 4.2. As shown, the City's total potable water supply for FY 2015/2016 was approximately 480,310 AFY; the total wastewater flows for 2016 was approximately 377,645 AFY; and the total recycled water demand for 2015 (including injection at the barriers) was approximately 74,896 AFY.

Table 4.2 Demand and Flow Summary by Planning Year				
Summary Report				
One Water LA 2040 Plan				
Year and Hydrologic Condition	Potable Water Demands (AFY)	Wastewater Flows (AFY)	Recycled Water Demand (AFY)	Stormwater Flows (AFY)
2016 (Actual)	480,310	377,645	74,896	354,907
2020				
Normal Year	465,800	361,842	91,572	831,360
Wet Year	435,200	371,877	91,572	1,840,500
Dry Year	465,800	346,088	91,572	360,672
2025				
Normal Year	504,000	384,762	130,572	831,360
Wet Year	471,800	394,797	130,572	1,840,500
Dry Year	504,000	369,008	130,572	360,672
2030				
Normal Year	501,100	383,022	138,472	831,360
Wet Year	468,500	393,057	138,472	1,840,500
Dry Year	501,100	367,268	138,472	360,672
2035				
Normal Year	508,900	387,702	141,072	831,360
Wet Year	475,800	397,737	141,072	1,840,500
Dry Year	508,900	371,948	141,072	360,672
2040				
Normal Year	520,200	394,482	143,072	831,360
Wet Year	486,400	404,517	143,072	1,840,500
Dry Year	520,200	378,728	143,072	360,672

The projected future flow summary for future planning years under normal-, dry-, and wet-year conditions is also shown on Table 4.2 (see TM 2.1, Volume 8, for details). Table 4.2 provides an order-of-magnitude summary of all major future water flows in the City. These flows represent baseline conditions and exclude the impact of flows and demands explored in the long-term integration analysis presented in Chapter 6.

Potable water demands are projected to be equal in normal- and dry-year conditions. Wet-year demands are expected to be approximately 6 percent lower than normal-year conditions. Potable water demands are expected to increase approximately 10 percent between year 2015 and year 2040.

Wastewater flows are projected to be 2.5 percent higher in a wet year compared to a normal year and 4 percent lower in a dry year compared to a normal year. Wastewater flows are expected to increase approximately 10 percent between year 2015 and year 2040.

Recycled water demands are projected to be equal in normal, wet, and dry years. Recycled water demands are expected to increase approximately 90 percent between year 2015 and year 2040.

Stormwater flows in a wet year are more than double of a normal year. Stormwater flows in a dry year are less than half of a normal year. Stormwater flows are not expected to change significantly between year 2015 and year 2040.

These baseline flows are used in the MBT, which evaluates flow impacts on top of these baseline flows and demands.

CURRENT INTEGRATION OPPORTUNITIES

Chapter 5 presents the current integration project opportunities that were identified as part of the One Water LA 2040 Plan (Plan) development. Current integration opportunities are existing and/or planned projects that have or could include a water management component and that require collaboration of multiple City departments and/or regional agencies. The purpose of these projects is to demonstrate how water management benefits can be integrated in a project through multi-agency collaboration.

The Chapter starts with a summary of how the current integration opportunities were identified during the Plan development. Subsequently, the screening and ranking process of the initial 44 opportunities is described. The Chapter concludes with a brief description of the top five current integration opportunities, which are also referred to as "Case Studies" because these projects could function as role models for taking a "One Water" approach during project development and implementation.

A more detailed description of the current integration opportunities analysis can be found in Technical Memorandum (TM) 3.1 (Current Integration Opportunities Case Study Selection) and TM 3.2 (Current Integration Opportunities – Case Studies), both included in Volume 5.

5.1 PURPOSE

The purpose of developing current integration opportunities is to create momentum for these projects. In turn, these projects can be implemented and function as examples or templates for similar projects by establishing the necessary relationships, policies, agreements, and/or cost sharing arrangements required to implement multi-departmental/agency projects.

5.2 SELECTION AND DEVELOPMENT PROCESS

This section describes the current integration opportunities selection and development process. The process flow diagram shown on Figure 5.1 illustrates the overall identification, selection, and development process. As shown on Figure 5.1, the entire process consisted of five steps, namely, gathering of integration opportunities ideas (step 1), followed by screening of integration opportunities (step 2), development of project fact sheets for the top 10 opportunities (step 3), ranking of these opportunities (step 4), and concluding with conceptual development of the top five Case Studies. The process and findings of each step are summarized in the following subsections, while details can be found in TM 3.1 (see Volume 5).

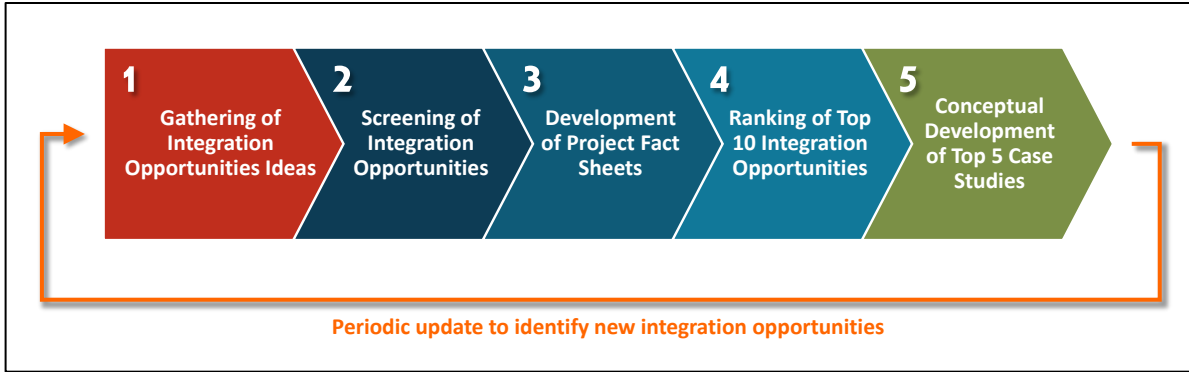

Figure 5.1 Case Study Selection and Development Process

5.2.1 Step 1 - Gathering of Current Integration Opportunity Ideas

On May 5, 2016, the One Water LA Group reached out to its Steering Committee to obtain a list of each department and agency's top three to five current project/planning effort integration opportunities. The purpose of obtaining the list of current integration opportunities was to create practical examples of interdepartmental/interagency collaboration, identify agreements and policies needed to resolve complexities hindering project implementation, and to highlight One Water LA "quick success" stories that provide multiple benefits. By mid-July 2016, a total of 44 water-related projects and/or planning efforts were received from 12 different departments/agencies of the Steering Committee, as summarized in Table 5.1. It is recommended that this process for gathering current integration opportunities be repeated on a periodic basis.

Table 5.1 Number of Current Integration Opportunities by Agency Summary Report One Water LA 2040 Plan	
Agency	Number of Identified Opportunities
LACFCD - LA County Flood Control District	2
LADOT - Los Angeles Department of Transportation	3
LADWP - Los Angeles Department of Water and Power	3
LARiverWorks - Los Angeles RiverWorks Office	6
LASAN - Los Angeles Sanitation	6
LAUSD - Los Angeles Unified School District	1
LAWA - Los Angeles World Airports	5
Los Angeles Zoo	3
Metro - Metropolitan Transportation Authority	4
MWD - Metropolitan Water District	2
POLA - Port of Los Angeles	4
RAP - Los Angeles Department of Recreation and Parks	5
Total	44

5.2.2 Step 2 - Screening of Integration Opportunities

To narrow down the list of current integration opportunities received during Step 1, the following screening criteria were applied to the initial list of 44 projects:

- *Does it support the Mayor's water goals?* This was a Yes/No criterion for each project in that selected Case Studies must contribute to and support Executive Directive No. 5 (ED#5) from the Mayor's office as well as the Sustainable City pLAn.
- *Does the project have visibility?* This criterion was a Yes/No answer used to characterize a project as having the potential for visibility and interest to Angelenos, as well as having the potential to generate One Water LA momentum and creating awareness about the importance of multi-benefit projects.
- *Does the project provide social/environmental justice?* This criterion was a Yes/No answer, with the purpose of determining if a project would benefit a disadvantaged community, contributing to social and environmental benefits in such communities.
- *Does the project have replicability potential?* This criterion was a Yes/No answer used to determine if a project has the ability to be replicated and serve as a role model, wherein lessons learned could be applied to other projects with similar characteristics.

Furthermore, the timing of each of the 44 projects was considered. Selected opportunities needed to be early enough in the planning process such that they could be positively influenced by the One Water LA Program effort, but not so early in concept that they could not occur within a reasonable timeframe. In addition, the goal of engaging and representing as many different City departments as possible (as lead agencies) contributed to selection of the top 10 current integration opportunities. Finally, the selection of projects also considered the project locations such that the projects are distributed sufficiently throughout the City. Collectively, this screening effort resulted in a list of the top 10 current integration opportunities.

5.2.3 Step 3 - Development of Project Fact Sheets

Due to the limited amount of information available for some of the projects, project fact sheets were developed for the top 10 opportunities to allow for further evaluation and subsequent ranking of these opportunities. Detailed information was collected from represented departments/agencies to develop the so-called "Project Fact Sheets" that included the following information:

- Project location
- Project description
- Lead department/agency and number of departments/agencies involved
- Timing
- Water type
- Required agreements and policies
- Implementation challenges

5.2.4 Step 4 - Ranking of the Top 10 Integration Opportunities

The project information documented in the fact sheets was used to score and rank the top 10 integration opportunities. A set of ranking criteria was developed to quantify scoring and establish ranking as summarized in Table 5.2.

Table 5.2 Scoring and Ranking Criteria Summary Report One Water LA 2040 Plan		
Criteria	Description	Scoring⁽¹⁾
Implementation Complexity	<ul style="list-style-type: none"> • Number of departments/agencies involved • Institutional agreements • Technical complexity • Constructability • Environmental issues • Extent of public outreach needed 	1 to 5
Visibility/Education Potential	<ul style="list-style-type: none"> • Number of people that can be reached at site annually • Ability to educate public • Potential for partnerships with educational institutions 	1 to 5
Disadvantaged Community	Potential ability of the project to enhance a disadvantaged community measured by the average household income of the neighborhood that the project is located in	1 to 5
Replicability	Ability to utilize lessons learned in the future at other project sites with similar characteristics	1 to 5
Unique Timing	Opportunity to implement the project in the next few years but with the ability to still influence the project elements (early planning stage)	1 to 5
Potable Water Offset	Amount of potable water offset (in acre-feet per year [AFY]) or estimated as low, medium, or high; this is the total offset/yield increase)	1 to 5
Stormwater Quality Improvement	Ability of a project to provide stormwater quality improvement benefits through Best Management Practices (BMPs) measured by the tributary area of a project	1 to 5
Multiple Water Components	Opportunity of a project to demonstrate One Water integrated planning by adding a bonus point for projects with both stormwater and recycled water components.	0 or 1
Note:		
(1) Scoring range from highest (5) to lowest (1)		

The scoring described in Table 5.2 was tabulated for the top 10 integration opportunities to establish a total project score and project ranking. Subsequently, the scoring was discussed and finalized with input from the One Water LA Team. The more complex projects received higher scores (i.e., potential to work through challenges and create momentum).













The ranking results are presented and graphically shown in TM 3.1 (see Volume 5). In addition, a complete listing of the top 10 integration opportunities along with the overall ranking, project name, water components, lead agency, and other project departments involved are presented in Table 5.3, with project locations in the City shown on Figure 5.2.

5.2.5 Step 5 - Conceptual Development of the Top 5 Case Studies

The top five ranked integration opportunities are also referred to as the top five Case Studies. As shown in Table 5.2, the following project opportunities were selected as the top five Case Studies:

1. **Advanced Treated Recycled Water Delivery to LAX and Scattergood Generating Station** – This project involves a new advanced water purification facility at the Hyperion Water Reclamation Plant (HWRP) to deliver advanced treated recycled water to Los Angeles International Airport (LAX) and Scattergood Power Plant/Generating Station (Scattergood).
2. **Capture of Off-Site Stormwater at LAUSD Schools** – This pilot study involves capture and treatment of off-site stormwater for reuse or recharge at a school site to serve as a role model for other school sites of the LAUSD.
3. **Rancho Park Water Reclamation Facility** – This project involves a new satellite water WRP to produce recycled water, which would be augmented with stormwater when available to serve non-potable water demands in the vicinity of Rancho Park (west LA).
4. **Restoration of G2 Parcel at Taylor Yard** – This project includes development of an approximately 41-acre former rail yard site, consisting of stormwater BMPs, potentially recycled water, and site remediation.
5. **Water Management Strategies for the LA Zoo's Master Plan** – This project includes the consideration of both stormwater and recycled water in the LA Zoo Master Plan to promote the use of stormwater BMPs and the use of recycled water for animal exhibits, washdown, and irrigation at the LA Zoo.

Based on these brief project descriptions, it can be concluded that the entire five-step process resulted in 10 current integration opportunities that represent a broad mix of project components, lead departments/agencies, and collaboration partners. Moreover, the top five projects include two stormwater projects, one recycled water project, and two projects including a combination of both.

Table 5.3 Top 10 Current Integration Opportunities and Top 5 Case Studies Summary Report One Water LA 2040 Plan			
Project Name ⁽¹⁾	Water Component	Lead Dept./ Agency	Department(s) Involved
Advanced Treated Recycled Water Delivery to LAX and Scattergood Generating Station		LASAN/ LADWP/ LAWA	N/A
Caballero Creek Park		RAP	BOE-LARiverWorks, LASAN
Capture of Off-Site Stormwater at LAUSD Schools		LAUSD	LASAN, LADWP, DSA
LA River Bike Path		Metro	BOE-LARiverWorks, LADOT, LASAN
MacArthur Park		RAP	BOE, LASAN, LADWP
Rancho Park Water Reclamation Facility		LASAN	LADWP, RAP
Restoration of G2 Parcel at Taylor Yard		BOE- LARiverWorks	HSR, LASAN, RAP, LADWP
Rory M. Shaw Wetlands Park		LACFCD	LADWP, LASAN, RAP, LACDPW
Water Management Strategies for the LA Zoo's Master Plan		LA Zoo	LADWP, LASAN, RAP
Wilmington Waterfront Development		POLA	LASAN, LADWP
 = Stormwater  = Recycled Water <u>Note:</u> (1) The projects are listed in alphabetical order. <u>Abbreviations:</u> LASAN = Los Angeles Bureau of Sanitation; BOE = Los Angeles Bureau of Engineering; LADOT = Los Angeles Department of Transportation; POLA = Port of Los Angeles; RAP = Los Angeles Department of Recreation and Parks; LAWA = Los Angeles World Airports; LARiverWorks = Los Angeles RiverWorks Office (part of BOE); HSR = California High-Speed Rail Authority; LADWP = Los Angeles Department of Water and Power; LACDPW = Los Angeles County Department of Public Works; DSA = Division of State Architect; Metro = Metropolitan Transportation Authority; N/A = not applicable			

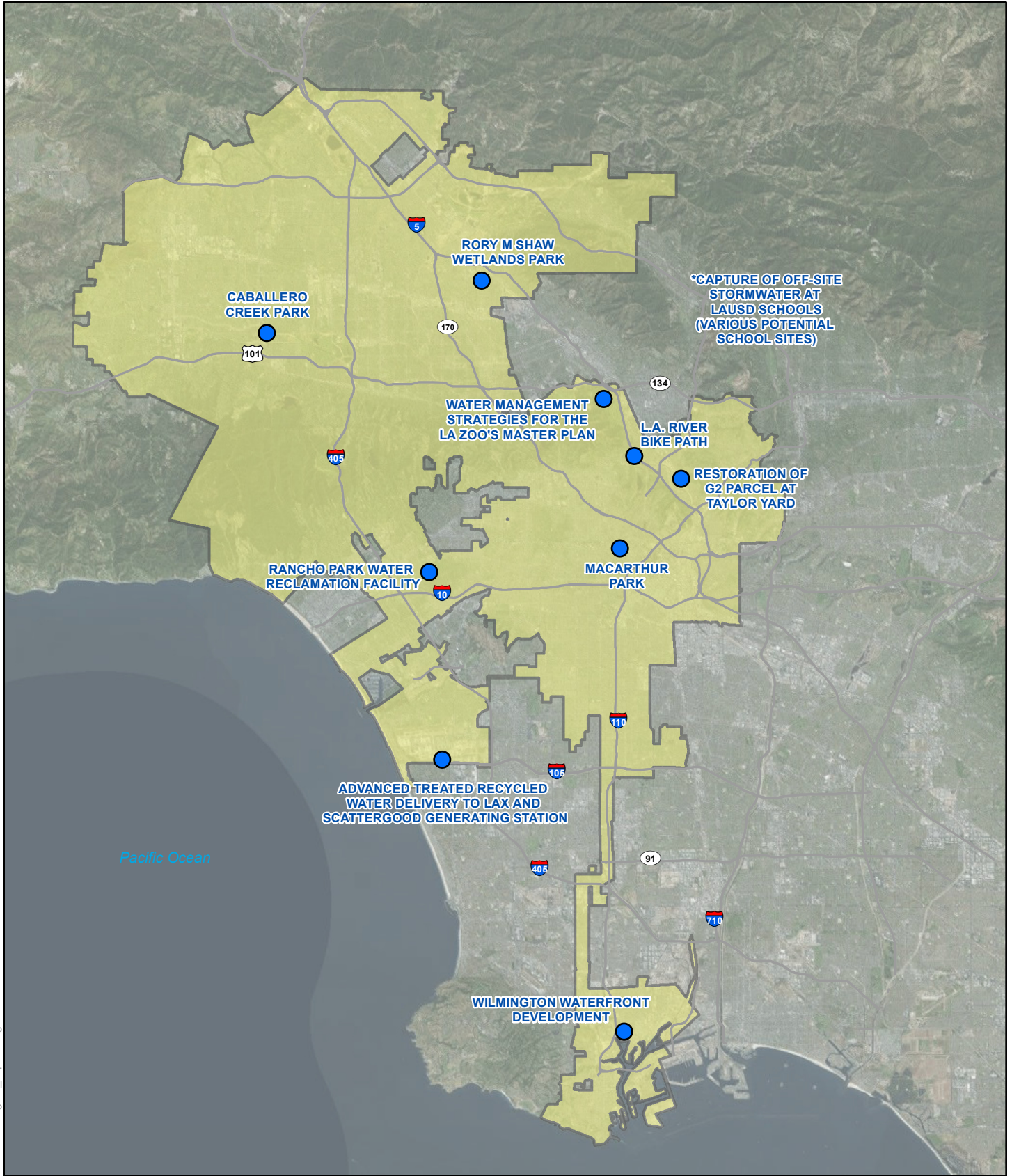

Document Path: E:\JACKIEBKU\O\W\LA\MXD\Fig5-3_Top10Integration.mxd

Legend

- City of Los Angeles
- Integration Opportunity Project Location

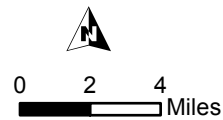

Figure 5.2
Location of Top 10
Integration Opportunities
 One Water LA 2040 Plan
 Summary Report

These top five Case Studies were developed in more detail in TM 3.2 (Volume 5), with two exceptions:

- **Rancho Park Water Reclamation Facility** – This project was initially developed as its own concept report. The project concept report is currently under development by City staff and therefore not included as part of the Plan. As ongoing project development discussions have not yet resulted in an updated feasibility study, TM 3.2 (see Volume 5) provides an abbreviated project description, which may include project elements that are no longer valid.
- **Restoration of G2 Parcel at Taylor Yard** – This project was removed from consideration as a Case Study during the development of TM 3.2 due to ongoing discussions regarding this project. The project was temporarily on hold during the development of TM 3.2 but is currently moving forward with the Bureau of Engineering. Information from the initial concept will be shared with the City team managing the project.

5.3 CURRENT INTEGRATION PROJECT DESCRIPTIONS

Project descriptions are provided for the following current integration Case Studies:

- Rancho Park Water Reclamation Facility
- Advanced Treated Recycled Water Delivery to LAX and Scattergood Generating Station
- Capture of Off-Site Stormwater at LAUSD Schools
- Water Management Strategies for the LA Zoo's Master Plan

As previously explained, the Case Study "Restoration of G2 Parcel at Taylor Yard" was removed from consideration as the project was (temporarily) put on hold by City staff.

Each of the following project descriptions include an initial overview of the project, followed by information on lead agency and interagency collaboration, objectives and benefits, cost, implementation considerations, as well as schedule and next steps. Note, these projects are at preliminary stages and require a cost-benefit analysis and identification of funding sources. Depending on further analysis, these projects may or may not move forward.

5.3.1 Rancho Park Water Reclamation Facility

As explained in Section 5.2.5, this project was initially developed as part of the "Rancho Park Project Concept Report," which is summarized in TM 3.2 (see Volume 5). However, the original concept report is outdated because the project is currently further developed by City staff. As the ongoing project development discussions have not yet resulted in an updated feasibility study, the project descriptions provided in TM 3.2, and in the summary below may include project elements that are no longer valid.



The Rancho Park project is a multi-benefit park project with potable water reduction concepts. The location of Rancho Park is shown on Figure 5.3, while alternative project locations are shown on Figure 5.4.



Figure 5.3 Rancho Park Project Site Location



Figure 5.4 Alternative Project Locations

The project includes stormwater and recycled water reuse components, providing an excellent opportunity for integration into a multi-component project. The project has been expanded into considering two alternatives:

- **Alternative 1** – an on-site water reclamation facility (WRF) at the Rancho Park Golf Course/Cheviot Hills Recreation Center that would divert stormwater and wastewater to meet all non-potable demands in the Westside area.
- **Alternative 2** – an on-site WRF at the Rancho Park Golf Course/Cheviot Hills Recreation Center and an additional on-site WRF near the University of California, Los Angeles (UCLA) due to UCLA being the single largest potential non-potable customer in the area. Each facility would serve local non-potable demands.

Additional project information can be found in TM 3.2 - Integration Opportunities Case Studies (see Volume 5). Figure 5.4 includes Alternative 1 conceptual site location map and Alternative 2 potential service areas.

5.3.1.1 Lead Agency and Interagency Collaboration

The lead agency for this project is LASAN, supported by collaboration from LADWP and RAP.

5.3.1.2 Objectives and Benefits

The purpose of this multi-benefit project is to promote healthier watersheds, greater reliability of our water and wastewater systems, increased efficiency and operation of our utilities, enhanced livable communities, resilience against climate change impacts, and protection of public health. The multi-component approach at Rancho Park will provide opportunities to co-locate both stormwater and WRF in order to share infrastructure and centralize the operations and maintenance (O&M) of both systems.

5.3.1.3 Cost Estimates

The estimated capital cost for Rancho Park Water Reclamation Facility is \$58 million for an estimated yield of 1,860 AFY. These costs are for the first phase of the facility and do not include the required LADWP recycled water distribution piping. The estimated capital cost for all three phases is \$180 million for an estimated yield of up to 3,600 AFY; these values are used in Chapter 6 as Rancho Park Water Reclamation Facility was also evaluated as a future integration opportunity.

5.3.2 Advanced Treated Recycled Water Delivery to LAX and Scattergood

This project would deliver advanced treated recycled water from a small-scale Advanced Water Purification Facility (AWPF) located at the HWRP to LAX and Scattergood. Intended uses of the advanced treated recycled water are both commercial and industrial, such as cooling tower makeup water at both LAX and Scattergood, as well as toilet flushing utilizing a dual plumb water system at LAX. Key project components include the AWPF, distribution pump station, storage tank, and recycled water conveyance pipelines.



The project location and layout is shown in a map view on Figure 5.5. A 1.5 mgd Advanced Water Purification Facility (AWPF) would be constructed at the HWRP by LASAN. This facility is planned to be designed such that the production capacity can be expanded up to 5 mgd in the future. The AWPF would receive primary effluent and utilize treatment upgrades consisting of a membrane bioreactor (MBR), reverse osmosis (RO), ultraviolet (UV) disinfection, and an advanced oxidation process (AOP) to produce advanced treated recycled water.

The AWPF would include a distribution pump station to pump and deliver advanced treated recycled water. The pump station configuration needs to be determined in later planning stages and could include either a single pump station, or a dual pump station that delivers water to LAX and/or Scattergood.

The project would deliver advanced treated recycled water to LAX via an LADWP-owned 12-inch diameter pipeline, running north from HWRP along Pershing Drive. Once the pipeline bends east on World Way West, the pipeline enters Los Angeles World Airport (LAWA) property. The LAWA-owned 12-inch diameter pipeline would run east along World Way West to deliver the advanced treated recycled water to various customer sites. In addition, the project would deliver advanced treated recycled water through a LADWP-owned 8-inch diameter pipeline to Scattergood for cooling tower makeup water.

The estimated average LAX demand is 627 gallons per minute (gpm), with a peak demand approaching 1,500 gpm. For Scattergood, the recycled water demands include an average of 450 gpm, with a peak demand of 650 gpm. Hence, the total average demand of these customers is 1,067 gpm, which equates to roughly 1.5 mgd and 1,700 AFY.

5.3.2.1 Lead Agency and Interagency Collaboration

LASAN, LADWP, and LAWA are partnering to plan and implement this project. A multi-party high-level interagency Memorandum of Agreement (MOA) is needed to address commitment by all parties. In addition, two service agreements are needed to establish conditions and criteria for recycled water production and delivery. These are:

1. LADWP needs a service agreement with LAWA that specifies a water rate and performance assurance measures.
2. LADWP needs a service agreement with LASAN that specifies the water quality and delivery conditions for the advanced treated recycled water to the LADWP distribution system.

5.3.2.2 Objectives and Benefits

The project objectives and benefits include:

- Demonstrating the ability to produce potable reuse quality water at HWRP to facilitate future planning of indirect and direct potable reuse opportunities.
- Increasing recycled water production and use in the City, coupled with potable water offset.

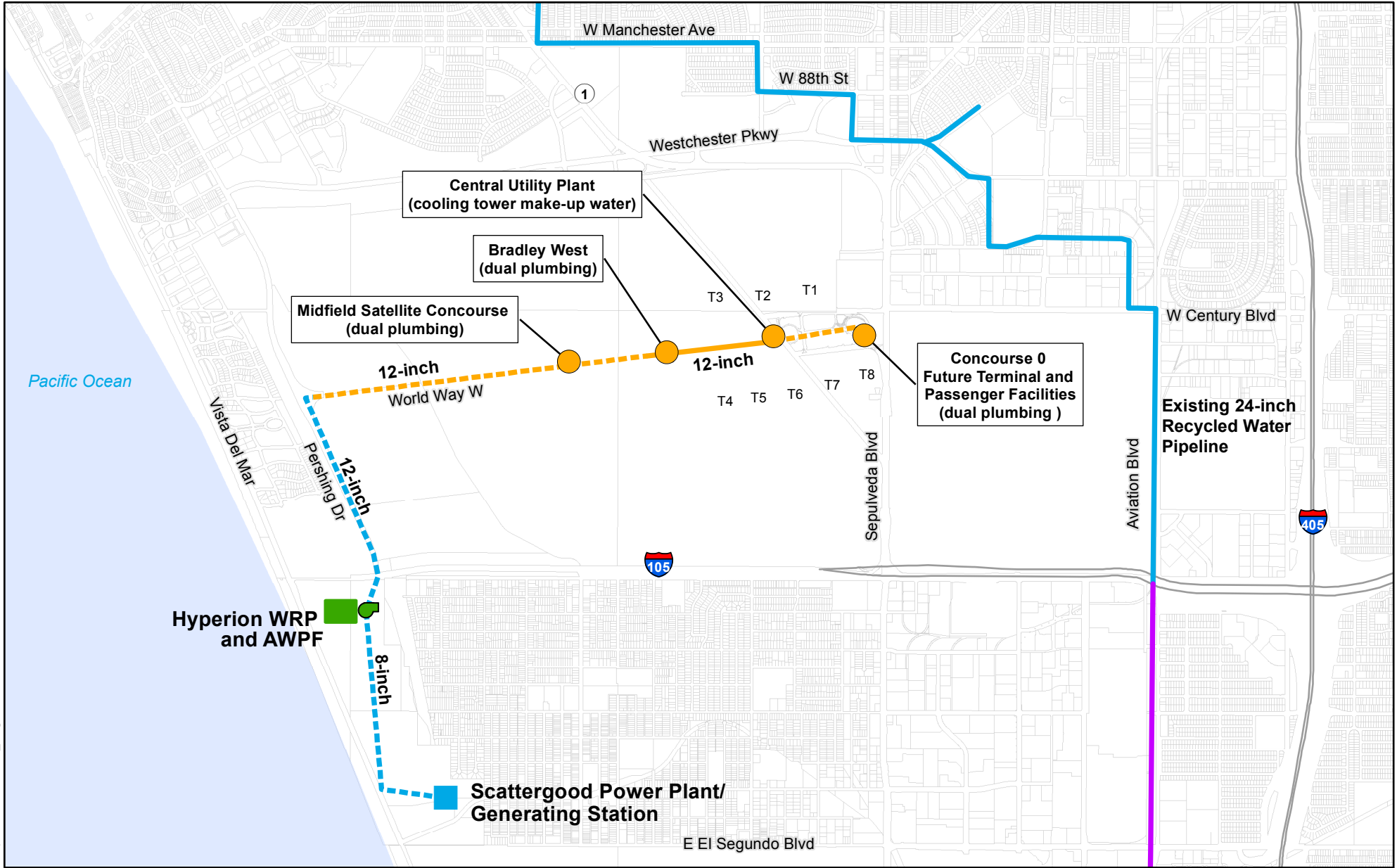

Legend

- Parcel
- Ownership
 - LADWP
 - LAWA
 - West Basin
- T# - LAX Terminal Number
- Pump Stations (LASAN)
- Planned/Future Recycled Water Pipeline
- Existing Recycled Water Pipeline

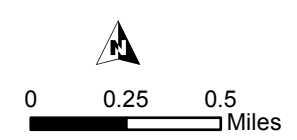

Figure 5.5 - Recycled Water Delivery to LAX and Scattergood: Project Location Map and Layout

One Water LA 2040 Plan
Summary Report

- Providing increased water supply reliability, portfolio diversification, and reduced dependence on purchased imported water.
- Increasing awareness of the benefits of recycled water through public outreach to the large amount of people, both residents and visitors, passing through LAX. There were approximately 80 million passengers at the airport in 2016. Passenger volume is projected to increase to 90 million annual passengers by year 2027 and 95 million by 2030.
- Demonstrating that the City leads by example by utilizing recycled water at two major facilities, LAX and Scattergood.

5.3.2.3 Cost Estimates

High-level cost estimates were based on preliminary planning-level information known as of January 2017, and costs reflect 2017 dollars. Project costs are estimated and summarized in Table 5.4. As shown, the total estimated capital cost is \$51.2 million, which includes \$36 million for the AWPf. The vast majority of costs, approximately \$42.9 million (88 percent), are associated with project components that are the responsibility of LASAN. The estimated capital cost of components to be constructed by LADWP and LAWA are \$4.0 million and \$4.3 million, respectively.

Table 5.4 Recycled Water Delivery to LAX and Scattergood Generating Station: Capital Cost Estimates Summary Report One Water LA 2040 Plan			
Responsible Agency	Component	Estimated Capital Cost (\$M)	Total (\$M, %)
LADWP	12-inch Pipeline from HWRP to LAX (approximately 3,900 ft)	\$1.7	\$4.0 M (8%)
	8-inch Pipeline from HWRP to Scattergood (approximately 4,900 ft)	\$1.7	
	Jack and Bore	\$0.42	
	Alternate Potable Water Backup	\$0.2	
LAWA	12-inch Pipeline on LAWA property	\$4.3	\$4.3 M (8%)
LASAN	1 MG Storage Tank	\$4.0	\$42.9 M (84%)
	250 hp Pump Station to LAX	\$1.5	
	150 hp Pump Station to Scattergood	\$0.9	
	400 hp Diesel Generator Backup	\$0.32	
	1.5 mgd Advanced Water Purification Facility	\$36.0	
	Potable Water Backup at AWPf	\$0.2	
Total		\$51.2	\$51.2

5.3.2.4 Implementation Considerations

The implementation considerations are described below.

- **Reliability/Redundancy for LAWA** – LAX would require similar supply reliability as potable water; therefore, measures must be taken to provide appropriate redundancies and potable water backup provisions. LASAN plans to install a potable water backup supply at the AWPf storage tank in order to provide redundant supply in case the treatment process is interrupted. This would serve as the primary backup supply.

In order to provide an additional layer of reliability for LAWA, another option could be for LADWP to construct and operate an alternate potable water connection. Various connection types should be piloted during the preliminary design stage. LADWP would need to work with the regulators to develop this additional layer of supply redundancy.
- **Compliance with Recycled Water Regulations** – The production, discharge, distribution, and use of recycled water are subject to federal, state, and local regulations. These regulations are complex and necessitate planning and coordination with the regulatory agency.
- **Construction in High-Traffic Area** – The pipeline alignments are in high-traffic areas; therefore, challenges are expected to require planning in order to divert traffic during construction.
- **Water Quality Requirements** – Separate pump stations may be needed to accommodate the different water quality needs for LAX and Scattergood.
- **Schedule** – All three City agencies must collaborate and adhere to an agreed-upon project schedule, requiring frequent communication and collaboration among each department's Project Manager.
- **O&M Considerations** – The primary project component that requires extensive O&M is the AWPf. Additionally, the pump station(s) need to be equipped with supervisory control and data acquisition (SCADA), as it would be pumping into a closed system. To avoid over-pressuring the system, it is recommended that the pump station be equipped with variable frequency drive (VFD) pumps and a surge tank for water hammer protection. Finally, the O&M responsibilities and communication protocols need to be clearly defined in an interagency agreement to minimize system interruptions.
- **Site Constraints** – HWRP is located on a relatively compact and built-out parcel, and the site allocated for the AWPf has space constraints. Therefore, it is going to be necessary during design to optimize the limited space available to appropriately layout and design all necessary project components.
- **LA County Health Department Approvals** – The LA County Health Department would need to approve the design to issue a permit.
- **Permit Challenges** – The new AWPf is going to require permits from the Air Quality Management District (AQMD) and Division of Drinking Water (DDW), environmental clearance with National Environmental Policy Act (NEPA)/California Environmental Quality Act (CEQA), and a variety of construction permits.

5.3.2.5 Schedule and Next Steps

The overall project schedule is estimated to be completed by 2020. The City has already developed a Memorandum of Agreement (MOA) between all three partnering agencies (LASAN, LADWP, and LAWA) that defines the commitment of moving forward and specifies the key responsibilities, commitments, and timeline for completion for each department. Next steps for continued development and implementation are listed below:

- Develop the necessary service agreement between LASAN and LADWP, as well as the service agreement between LADWP and LAWA.
- Develop a detailed schedule to include additional construction details with duration and lengths, as well as environmental documentation and regulatory agency coordination, with milestones identified.
- Initiate discussions with DDW to discuss compliance with recycled water regulations, as well as the need for a potable water backup plan.

5.3.3 Capture of Off-Site Stormwater at LAUSD Schools

This Case Study focuses on the feasibility of developing a pilot study for an LAUSD site to capture off-site stormwater. To determine the best site for the LAUSD pilot, a screening process was followed that narrowed down an initial list of 348 schools within 500 feet of a current Enhanced Watershed Management Program (EWMP) project site. Based on a variety of location criteria, the list was ultimately reduced to 11 school sites in the Ballona Creek watershed and 10 school sites in the Upper LA watershed. These potential 21 potential school sites for the off-site stormwater capture pilot are summarized TM 3.2 (see Volume 5).

The potential pilot study would consist of a pre-treatment system (off-school site), concrete tank, monitoring system, valves, and potential irrigation systems. Trash and solids could be removed from stormwater diverted from a local storm drain. Diverted stormwater could then be conveyed onto the selected school site and used for either infiltration or irrigation. Potential school sites have been grouped by watershed, with focus on areas where regional stormwater facilities could optimize infiltration and on-site use, meeting multiple objectives and benefits.

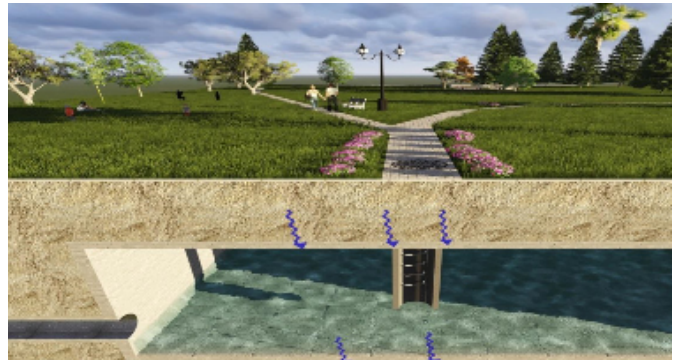

LASAN has developed a concept of a diverted stormwater system to help accomplish many objectives for the off-site stormwater capture pilot study. A conceptual layout of off-site stormwater capture to be conveyed onto the selected school site and used for infiltration is shown on Figure 5.6.

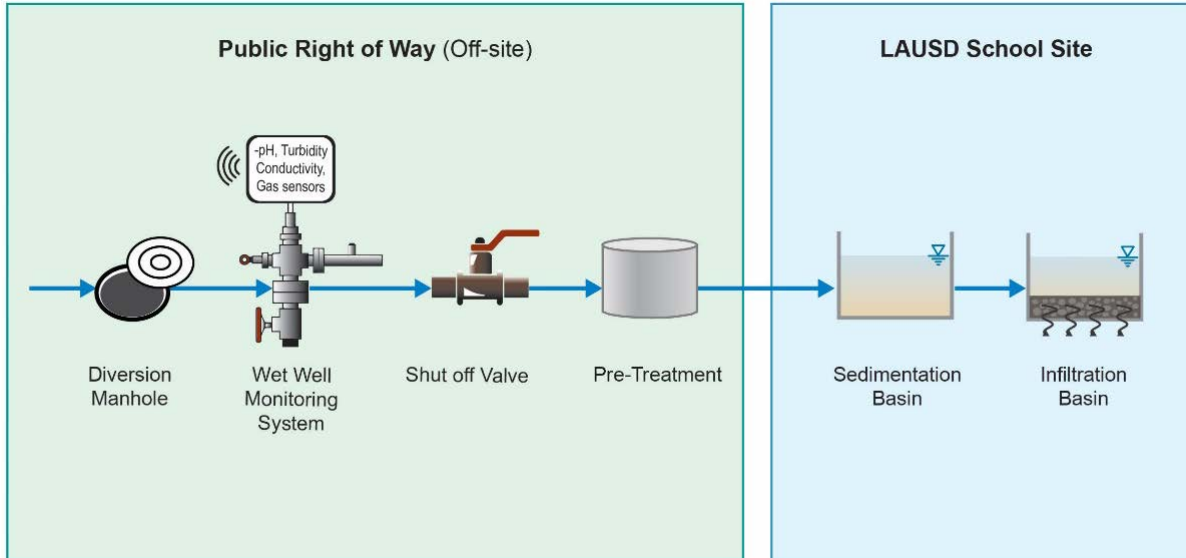

Figure 5.6 Conceptual Layout of Off-Site Stormwater Capture and On-Site Infiltration

5.3.3.1 Lead Agency and Interagency Collaboration

Coordination between LAUSD, LASAN, LADWP, the Department of Toxic Substances Control (DTSC), the State Water Resources Control Board (SWRCB), and the DSA is key for a successful pilot.

5.3.3.2 Objectives and Benefits

The objective of this pilot study is to successfully capture off-site stormwater runoff through the implementation of a BMP. The pilot study is expected to enhance the water quality, reduce local flooding, and help increase the amount of local water supply. Additional benefits include:

- **Potable Water Offset** – Reduce the City's reliance on purchased imported water and increase the amount of local water supply.
- **Visibility/Education Potential** – Help educate the public on sustainable practices that improve the quality of life.
- **Social/Environmental Justice** – Adding BMPs to local schools in a disadvantaged community would help the community protect the health of the local watershed, while providing other educational and social benefits.
- **Replicability** – Due to the large number of school sites located throughout the City, this Case Study has a tremendous potential for replication.
- **Stormwater Quality Improvement** – Reduce the volume of runoff delivered to receiving waters, thereby reducing the pollutants discharged, saving the City in treatment costs.

5.3.3.3 Implementation Considerations

The key implementation considerations that were identified are as follows:

- LAUSD's compliance requirements with their new National Pollutant Discharge Elimination System (NPDES) Municipal Separate Storm Sewer System (MS4) Permit – Evaluate where LASAN can help and/or partner with LAUSD to help meet LAUSD's new 2018 permit requirements for a Stormwater Phase II Small MS4 Permit.
- **Operations and Maintenance** – LAUSD prefers that the maintenance of pre-treatment activities occurs off their premises. Similar to many Prop O projects, they would like to have those pre-treatment screens, etc. in the streets or right-of-way (ROW). LAUSD is concerned that they would be burdened with operating and maintaining facilities for which they do not have resources to do the work.
- **Health and Safety** – LAUSD is concerned about the health of the children. Any stormwater project would need to take children's health into consideration.
- **Liability** – Indemnification and responsibility of the involved parties needs to be clarified for various scenarios.
- **Water Quality (list of constituents)** – Typical constituents found by land use to be evaluated in contributing sub-watershed. LA County's list of constituents by land use is an excellent place to find information.
- **Resources for Operations and Maintenance** – Identification of the agency(s) who have the skill sets and resources to provide operation and maintenance activities.
- **LAUSD Future Expansions** – Evaluate design requirements for a school where facilities are planned to be expanded in the future. Structural analysis that would enable constructing LAUSD's facilities above the Stormwater infiltration basin would need to be completed. Further, the all nearby structures would need to be evaluated to make sure they are adequate to handle stormwater infiltration and any resulting outside loads.

5.3.3.4 Cost Estimates

High-level cost estimates were based on preliminary planning-level information known as of January 2017, and costs reflect 2017 dollars. The capital project costs for off-site stormwater capture and treatment systems combined with on-site stormwater infiltration were estimated based on other stormwater projects that the City has completed (i.e., via Proposition O). Cost estimates were prepared utilizing unit construction cost and markup assumptions as documented in TM 5.1 (See Volume 5).

As site conditions, proximity to the targeted storm drain, and the stormwater capture potential (flow) would vary considerably between school sites, the estimated capital costs are also expected to range considerably. However, most projects would have many common project elements such as a diversion maintenance hole, a wet well equipped with a monitoring system, shutoff valve, stormwater treatment, sedimentation basin, infiltration tank, and associated piping and pumping. Based on the preliminary sizing presented in TM 3.2 (see Volume 5), the estimated capital cost is expected to range from \$10 million to \$25 million per school site. In addition, O&M costs would need to be accounted for in project feasibility analysis and budgeting.

5.3.3.5 Schedule and Next Steps

The schedule is not yet determined. Construction would accommodate LAUSD's school calendar. Next steps include:

- Selection of optimal school site(s) based on the following criteria: Saturated Hydraulic Conductivity, Depth to Groundwater, Estimated Usable Area, Site Size, Upstream Watershed Land Use, Water Quality Improvements, Community (Disadvantaged/Severely Disadvantaged), and LAUSD's CIP List.
- Development of an agreement (i.e., a Memorandum of Understanding) between LAUSD and LASAN
- Evaluation of potential sites where LASAN can help and/or partner with LAUSD to comply with the 2018 MS4 permit

5.3.4 Water Related Opportunities for the LA Zoo's Master Plan

The Los Angeles Zoo Department (LA Zoo) identified the necessary steps to implement recycled water use in the LA Zoo and incorporating stormwater capture and infiltration components as part of their Master Plan.

The goal is to decrease the LA Zoo's potable water use to help achieve the City's local water supply goals. Through a series of meetings, the following two specific ongoing efforts were identified as possible opportunities for the Zoo and One Water LA to collaborate, namely the LA Zoo Master Plan and the new Park Event Center.



As summarized in Table 5.5, this Case Study explores using recycled water for LA Zoo operations alongside the feasibility of implementing stormwater BMPs into new exhibits and the Event Center's design.

Table 5.5 Potential Recycled Water and Stormwater Uses at the LA Zoo Summary Report One Water LA 2040 Plan		
	LA Zoo Master Plan	Event Center
Recycled Water Activities/Use	Irrigation	Irrigation
	Washdown	Restrooms
	Restrooms	
	Exhibit Use – treatment systems, pool filling, aesthetics, ponds, etc.	
Stormwater Activities/Use	Infiltration	Infiltration
	Pervious Pavement	Pervious Pavement
	Rain Gardens, Rain Barrels	Rain Gardens, Rain Barrels
	Underground SW System	
	Storage Tank and Pump for Capture and Reuse	

The Zoo's current water use and water-related activities have been identified. In turn, potential uses for recycled water, and the total estimated potable water offset potential are summarized in Table 5.6. Quantification of potential stormwater capture and use has not yet been determined.

As shown in Table 5.6, the LA Zoo has the potential to offset more than 64 million gallons per year, which equates to nearly 0.2 mgd or 200 AFY. The LA Zoo contributes to 90 percent (180 AFY) of the potable water offset potential, while the Event Center accounts for the remaining 10 percent (20 AFY).

The Zoo's largest water demand use is for irrigation, followed by the animal exhibits. The zoo currently has 15 recirculating life-support systems, which vary in treatment process dependent on the animals' needs. These life-support systems are currently supplied with potable water, however, recycled water may be a potential alternate supply source that could be used for select animal exhibits. Further research is needed to determine if the treatment system is sufficient to meet the animal's needs if recycled water is to be used instead of potable water.

An extensive analysis of the Zoo's existing facilities, recycled water use, and stormwater capture opportunities were evaluated. A full list of recommended future activities and areas for additional studies is included in TM 3.2 (see Volume 5).

Table 5.6 Potential Potable Water Demand Offsets Summary Report One Water LA 2040 Plan		
Proposed Activity	Estimated Recycled Water Amount (gal/yr)	Stormwater Capture and Reuse Amount
LA Zoo		
Recycled Water Use – Washdown (animal holding areas)	4,778,000	
Recycled Water Use – Irrigation	36,089,000	
Recycled Water Use – Exhibits (treatment systems, ponds, aesthetics, etc.)	13,354,000	
Recycled Water Use – Power Washers	1,349,000	
Restrooms	2,363,000	
Potential Stormwater Capture and Reuse (landscape and planters)		TBD
<i>Subtotal – LA Zoo</i>	<i>57,933,000 (~180 AFY)</i>	<i>TBD</i>
LA Zoo Event Center		
Recycled Water Use – Irrigation	879,000	
Recycled Water Use – Restrooms	5,565,000	
Potential Stormwater Capture and Reuse		TBD
<i>Subtotal – Event Center</i>	<i>6,444,000 (~20 AFY)</i>	<i>TBD</i>
Grand Total	64,377,000 (~200 AFY)	TBD
Abbreviations: gal/yr = gallons per year; TBD = to be determined		

5.3.4.1 Lead Agency and Interagency Collaboration

The lead agency is the LA Zoo, with support from LASAN, LADWP, RAP, and the United States Department of Agriculture (USDA).

5.3.4.2 Objectives and Benefits

The City's overarching objectives of the One Water LA Program is to improve stormwater and receiving water quality, reduce the amount of imported water supply purchases, and increase the amount of local water supply by implementing integrated multi-benefit projects. This Case Study can serve as a guide to other city departments and zoos across the country also looking to reach similar goals. Other benefits include:

- **Visibility/Education Potential** – LA Zoo is open to ideas of marketing the One Water LA Program and informing their customers on the importance of water conservation in order to get the word out on what the City of LA is doing with regard to water. The LA Zoo currently displays educational signs along the promenade to inform LA Zoo visitors about the parking lot's sustainable water landscape and stormwater management features. Highlighting the water conservation methods implemented at the zoo would serve great educational value.
- **Social/Environmental Justice** – The LA Zoo is visited by nearly 1.8 million people every year, including about 500,000 school-aged children of different socio-economic backgrounds.
- **Replicability** – Zoos and other animal facilities are often major water users. This Case Study could be replicated by other zoos in the country and also applied to a large number of animal shelters and similar facilities throughout the City.
- **Stormwater Quality Improvement** – BMPs would serve to mitigate stormwater runoff by capturing and infiltrating rainwater before runoff is generated.

5.3.4.3 Cost Estimates

High-level cost estimates were based on preliminary planning-level information known as of January 2017, and costs reflect 2017 dollars. The cost of incorporating stormwater capture BMPs and recycled water will depend on the projects listed in the LA Zoo Master Plan. Based on the recommendations of this Case Study, the estimated capital costs for incorporating recycled water and stormwater capture are \$20 million and \$76 million, respectively.

5.3.4.4 Implementation Considerations

Implementation considerations can be divided into pertinent recycled water regulations and implementation phases and funding as follows:

- **Pertinent Recycled Water Regulations** – All zoos in the United States are regulated by the USDA's Animal and Plant Health Inspection Service. The USDA develops and enforces the regulations concerning animal welfare (Animal Welfare Act). However, since the regulations are not specific to the use of recycled water, the following requirements have to be met:
 - Animals must have a potable water source for drinking water.
 - The recycled water cannot cause any harm to the animals.
 - The veterinary staff must approve the use of recycled water.
 - If recycled water is used, then the inspector would conduct monitoring on the animals' health to be certain that the recycled water does not cause any harmful effects.
- **Implementation Phases and Funding** – Stormwater and recycled water project elements would be prioritized and phased, pending available funding (capital and O&M).

5.3.4.5 Schedule and Next Steps

The project schedule is based on the design and construction phase of each of the following efforts:

- **Master Plan Update** – The LA Zoo Master Plan is expected to be completed in late 2017. After that, project implementation can be phased.
- **Event Center** – Design of the Event Center is expected to be completed in 2017.
- **Implementation Phase** – The implementation phase of the Master Plan is going to depend on available funding, new regulations, animal needs, and goals of LA Zoo management.

The following next steps to advance the incorporation of water management strategies for both stormwater and recycled water at the LA Zoo include:

- Implement the use of recycled water for irrigation in the Master Plan (long-term) and Event Center Design (short-term).
- Implement recycled water use for washdown and power-washing activities at the LA Zoo.
- Incorporate stormwater management BMPs in the Master Plan Update and Event Center Design.
- Determine if there are any additional agreements needed.
- Verify if the treatment system is sufficient to meet the animals' water quality needs if recycled water is used instead of potable water.
- Determine recycled water connection options to the LA Zoo.
- Retrofit all eligible exhibits (based on location, sensitivity, and water treatment system) to connect to a future recycled water distribution system within the LA Zoo. For redundancy, it is recommended that a backup connection is maintained with the existing potable water system.
- Evaluate permeable area in the LA Zoo and determine the amount of area available for stormwater capture and infiltration.

5.4 **ADDITIONAL CURRENT INTEGRATION OPPORTUNITIES**

In addition to the top 10 current integration opportunities described in this Chapter and the other 34 current integration opportunities initially identified with the Steering Committee as described in Section 5.2.1, other integration opportunities were captured to provide a "living" project/concept ideas list. This list also includes new ideas from stakeholders and other projects that emerged during the development of this Plan. The full listing of all identified current integration opportunities is included in TM 3.2 (see Volume 5). At this time, a number of project ideas were suggested for further exploration, as described in TM 3.2 (Current Integration Opportunities – Case Studies), included in Volume 5. Some of these projects are highlighted below:

- **MacArthur Park** – The MacArthur Park project is a 30-acre park site located at 2230 West 6th Street, Westlake, south of West 6th Street and north of West 7th Street, immediately west of downtown Los Angeles. The project would include stormwater BMPs, in-lake improvements,

and possibly a recycled water pipeline. BMPs and water treatment technologies would be used to capture, store, and treat runoff from the watershed upstream of MacArthur Park. In-lake improvements would consist of floating wetlands with recirculating constructed stream systems, aeration devices, and recirculated lake water pumping systems strategically placed to improve oxygenation levels in the lake. A potential 1.3-mile recycled water pipeline alignment could extend from the connection point at the Los Angeles Convention Center to MacArthur Park via Pico Boulevard and Alvarado Street to provide supplemental water for MacArthur Park Lake.

- **San Pedro Gateway** – The San Pedro Gateway project would employ stormwater BMPs and water treatment technologies to store and treat runoff from the watershed upstream of the San Pedro Gateway Parcel. By capturing and reusing runoff, the entire load of pollutants of concern in the captured runoff, including bacteria and metals, would be removed from discharging to the San Pedro Bay thus providing water quality and aesthetic benefit to the San Pedro Gateway, benefitting multiple stakeholders including Caltrans, the Mayor's Office, the San Pedro community, and the Port of Los Angeles.
- **LARiverWorks In-Channel Actions** – City Departments and Regional Entities could explore various ways to use the LA River channel and its tributaries as detention facilities following rain events, such as with inflatable dams or other modifications. Preparation in coordination with regional and federal leads should be community-focused and done in advance of rainy seasons.
- **LARiverWorks Large-Scale Retention Projects** – Large areas in the City (e.g., Chatsworth Reservoir, Van Nuys Airport, Dodger Stadium parking lot, etc.) could be aggressively evaluated for stormwater capture, treatment, and infiltration potential.
- **Metro LA River Bike Path Gap Closure Project (Downtown)** – This is primarily a transportation project but needs to maintain flood control capacity of the LA River and not preclude future revitalization efforts in the project area. There could be opportunities to incorporate potential green infrastructure components.

5.5 NEXT STEPS

In addition to the next steps identified for the five Case Studies described above, it is recommended that the City conduct periodic review of the "living" project ideas list. The purpose of this periodic review, as depicted on Figure 5.1, is to identify any missing or new projects and to determine which projects are most beneficial to explore further when circumstances change. And Policy #11 recommends creating a city-wide database to identify collaborative opportunities for water-related multi-benefit projects. The same process of project fact sheets, project scoring, and Case Study descriptions presented in TM 3.1 and TM 3.2 (Volume 5) could be utilized to help the City decide which integration opportunities are most beneficial to achieve the One Water LA vision and objectives. Some planning-level assumptions regarding the implementation, cost, and phasing of all current integration opportunities are included in the timelines presented in Chapter 9.

It is important to note that, although the top Case Studies are highlighted in the Plan, the City will continue to evaluate all current integration opportunities with the purpose of furthering collaboration and projects with multiple benefits.

FUTURE INTEGRATION OPPORTUNITIES

Chapter 6 presents the future integration opportunities that were identified as part of the One Water LA 2040 Plan (Plan) development. Future integration opportunities are a mix of projects and programs called "concept options" that support the One Water LA objectives and help the City prepare for a variety of future scenarios through and beyond 2040. In addition, these concept options help support or exceed the Sustainable City pLAN goals, and support LADWP's 2015 Urban Water Management Plan (UWMP). LADWP's 2015 UWMP already provides a strategy for the City to meet the Sustainable City pLAN goals for water use efficiency and local water supply through 2035.

Chapter 6 starts with a summary of how the future integration opportunities were identified during the Plan development. Subsequently, the criteria development and ranking process of the initial 25 opportunities (also referred to as concept options) is described. This Chapter concludes with a brief description of the preferred portfolio, which consists of the most desired future integration opportunities to achieve the One Water LA Vision and support the Sustainable City pLAN goals.

A more detailed description of the future integration opportunities analysis can be found in TM 5.1 (Basis of Planning), TM 5.2 (Project Development), and TM 5.3 (Portfolio Development and Evaluation), all of which are included in Volume 5.

6.1 PURPOSE

The purpose of developing future integration opportunities is to identify strategic projects that support achievement of the Sustainable City pLAN goals relative to water quality and water supply, to work toward fulfilling the key objectives and guiding principles of One Water LA, and to bring focus to multi-benefit projects. This effort complements other key City planning documents, such as the 2015 UWMP, Stormwater Capture Master Plan (SCMP), the four Enhanced Watershed Management Plans (EWMPs), and the 2012 Recycled Water Master Planning documents. Results of this evaluation provide a prioritized list of future concepts to guide the City with decision-making regarding which concept ideas are most viable for further study and potential implementation by year 2040 or beyond.

6.2 POTENTIAL FUTURE INTEGRATION STRATEGIES

One Water LA's long-term integration strategies can be divided into nine different strategic approaches to water management. The nine potential strategies that were evaluated as part of this Plan are described below in alphabetical order:

- **Distributed Stormwater Best Management Practices (BMPs)** – A program of many small-scale projects that would involve any technology, process, siting criteria, operating method, measure, or device that controls, prevents, removes, or reduces pollution from stormwater at a local level. Distributed stormwater projects are designed to capture stormwater prior to collection in the storm drain, which includes green streets and parcel level BMPs such as cisterns, rain gardens, and bioswales.

- **LA River Storage and Use** – Projects that would involve the use of (inflatable) dams, weirs, or other devices to allow (seasonal) storage of flows in the LA River, which would help the City to balance water supply and river needs.
- **Non-Potable Reuse (NPR or Purple Pipe)** – Projects that would expand the City's purple pipe network to deliver recycled water to new customers that can use recycled water for irrigation, industrial cooling, street sweeping, dust control, and environmental uses. NPR could be implemented in various configurations from any of the City's four water reclamation plants.
- **Low Flow Diversions** – Projects that would increase the number of low flow diversions (LFDs) in the City, which are structures designed to route urban runoff and stormwater from the storm drain into the sewer collection system. This concept could be implemented at strategic locations throughout the City to increase flows to the City's water reclamation plants to increase the potential for water recycling through non-potable reuse or potable reuse.
- **Ocean Water Desalination** – A potential Ocean Desalination Plant near the Hyperion Water Reclamation Plant that would remove salinity from ocean water using ultrafiltration and reverse osmosis membrane processes to a sufficient level to meet drinking water standards.
- **Potable Reuse with Groundwater Augmentation** – Projects that would infiltrate or inject recycled water into a groundwater basin that could be used as potable water after extraction and further treatment. Groundwater augmentation could be implemented in various configurations from any of the City's four water reclamation plants. This strategy is also known as Indirect Potable Reuse (IPR).
- **Potable Reuse with Raw Water Augmentation** – Projects that would deliver advanced treated recycled water (purified water) to a conventional water treatment plant before distributing into a potable water system. Raw water augmentation could be implemented in various configurations from any of the City's four water reclamation plants pending regulatory approvals. This strategy is also known as Direct Potable Reuse (DPR).
- **Potable Reuse with Treated Water Augmentation** – Projects that would deliver advanced treated recycled water (purified water) directly to a potable water system. Treated water augmentation could be implemented in various configurations from any of the City's four water reclamation plants pending regulatory approvals. This strategy is also known as DPR.
- **Regional or Centralized Stormwater BMPs** – Large-scale projects that involve structural solutions that capture and treat, and potentially recharge, urban runoff and stormwater at a regional level. These projects can contain multiple green infrastructure elements.

In May 2017, over 300 stakeholders were requested to provide input on the above described strategies. The survey was completed by 54 stakeholders who shared the most favorable and least favorable strategies, which is illustrated on Figure 6.1. It should be noted that at the time of the survey, the new California Potable Reuse terminology was not adopted yet. Hence, the Potable Reuse Raw Water Augmentation and Potable Reuse Treated Water Augmentation were still bundled under DPR. A separate ranking is therefore not available.

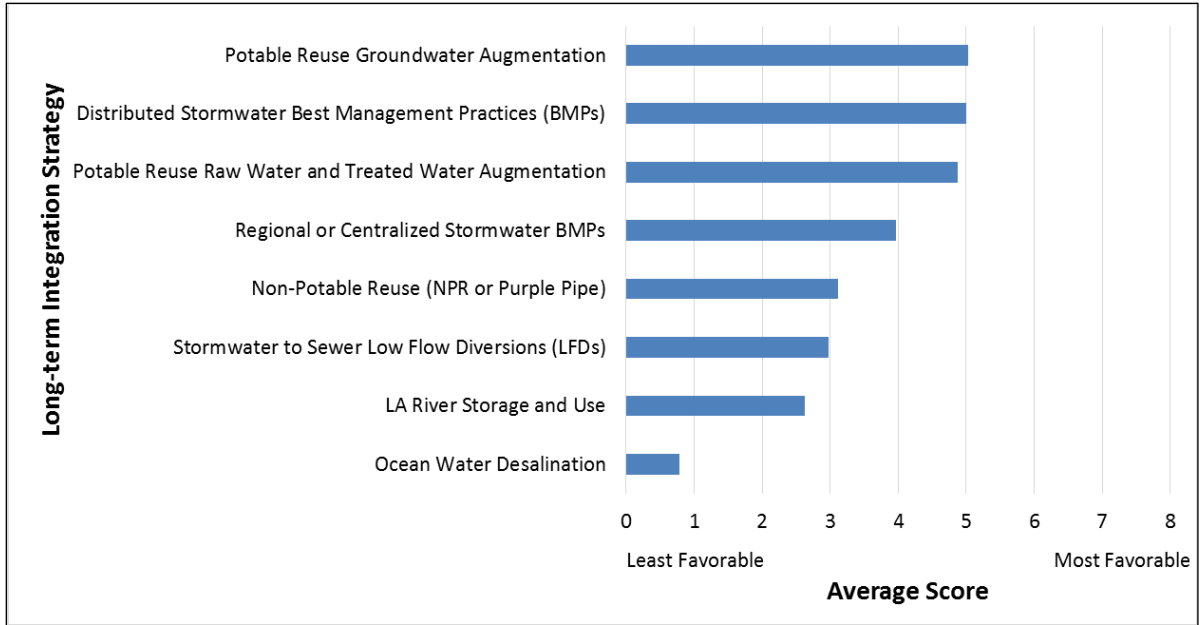

Figure 6.1 Future Integration Strategy Stakeholder Survey Results

The feedback received from stakeholders was analyzed and the results were presented at the subsequent Stakeholder Workshop. In the following evaluation process, the stakeholders' future integration strategy preferences were considered. Ultimately, all strategies, with the exception of ocean desalination, were included in the portfolio evaluation and plan recommendations. Ocean desalination was eliminated because the City has many more attractive potable reuse alternatives and stormwater strategies available that collectively can provide sufficient local supplies while avoiding environmental concerns, such as harm to marine life and high carbon footprint associated with ocean desalination. As shown on Figure 6.1, the elimination of ocean desalination as a water management strategy is consistent with the preferences of the One Water LA stakeholder group.

6.3 EVALUATION PROCESS

The future integration opportunities evaluation process was used to identify the most beneficial mix of concept options that could improve stormwater quality, increase stormwater capture, and supplement the City's local water supplies to further offset purchased imported water supplies increasing local supply resiliency, specifically during dry conditions. These most beneficial concept options are intended to provide alternative water management strategies in case some of the currently planned projects and programs need to be adjusted or to plan ahead for projects beyond year 2040.

As part of the future integration opportunity evaluation, the concept options were developed, evaluated, scored, and ranked. The most promising concepts are combined and prioritized for incorporation in the dynamic trigger-based One Water LA Implementation Strategy described in Chapter 9.

6.3.1 Methodology Overview

The approach and methodology for the future integration opportunities evaluation, is schematically presented on Figure 6.2, and followed by a brief discussion of the evaluation criteria, concept scoring and grouping, and final evaluation using the Mass Balance Tool (MBT) to determine priority concepts. As shown on Figure 6.2, the future opportunities evaluation process can be divided into three major phases and seven separate steps. The three phases and seven steps are described below.

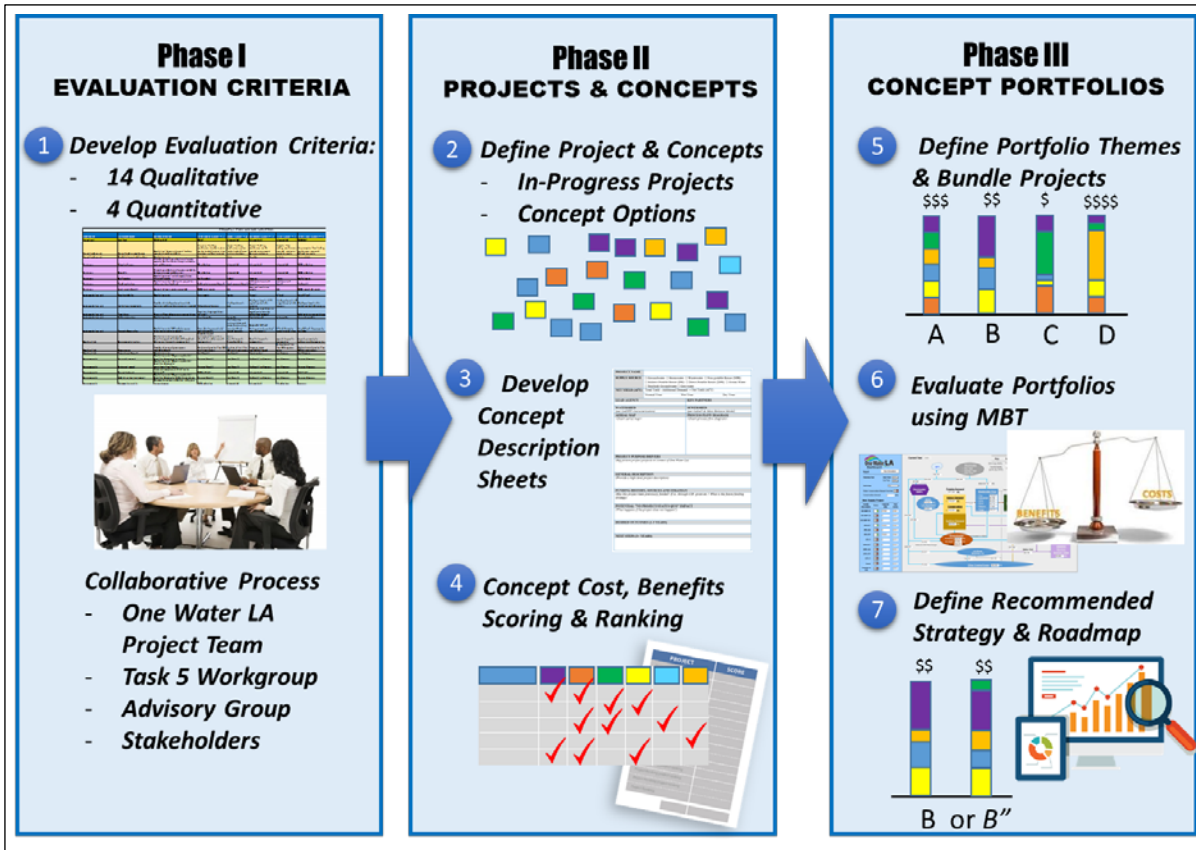

Figure 6.2 Evaluation Methodology

Phase I - Development of Evaluation Criteria

- **Step 1** was the development of the evaluation criteria through a collaborative process with the One Water LA 2040 Plan project team, Advisory Group, and stakeholders. A total of 18 criteria, along with individual weighting factors, were developed, mostly consisting of qualitative criteria and a few quantitative criteria. These criteria and their measures are described in more detail in Section 6.3.2, while the individual weighting factors are discussed in Section 6.3.3.

Phase II - Define and Score In-Progress Projects and Concept Options

- **Step 2** was the definition of major future water projects and concepts that could be implemented. These projects and concepts were divided into two categories: 1) In-Progress Projects and 2) Concept Options.
 1. In-Progress projects are projects that will be performed independent of the One Water LA 2040 Plan, as these projects are already defined in other completed planning efforts and are assumed to be moving forward at this point in time.
 2. Concepts options are major water opportunities that are not yet funded or in a capital improvement program (CIP, and are more uncertain. These concept options are being evaluated as part of the Plan's future integration opportunities evaluation process to determine whether they should be advanced and included in the Implementation Strategy or eliminated from further evaluation. Additional evaluation of each recommended concept option will be required.
- **Step 3** consisted of the development of Project and Concept Description Sheets that summarize the key characteristics of the in-progress projects and concept options. The in-progress projects were briefly summarized, while the concepts options were described in more detail and include descriptions for each of the major evaluation criteria in order to support the concept option scoring process.
- **Step 4** consisted of evaluating and scoring the concept options benefits utilizing the scoring criteria, measures, and weighting factors. The concept options were grouped by future integration strategy, and the concepts with the most perceived benefits (ranking the highest) were prioritized and moved forward into the portfolio evaluation phase. Los Angeles Department of Water and Power (LADWP) and Los Angeles Sanitation (LASAN) collaboratively reviewed the scoring results and confirmed which concept options are to move forward into the portfolio evaluation phase.

Phase III - Define and Evaluate Concept Portfolios

- **Step 5** consisted of the development of themed concept portfolios that combined concept options that matched the portfolio themes. Similar to the evaluation criteria, the concept portfolios were developed through a collaborative process with the Plan project team, Advisory Group, and stakeholders. A total of five concept portfolios were developed, including a "benchmark" portfolio.
- **Step 6** consisted of the portfolio evaluation utilizing both the concept evaluation criteria developed in Step 1 and the Mass Balance Tool (MBT) developed as part of the Plan. The total planning level estimated cost of each portfolio was compared with a total benefit score to obtain a cost-benefit ratio to compare the five portfolios.
- **Step 7** consisted of the development of the preferred mix of concepts by creating a preferred portfolio that combined the best combination of concepts that result in a maximum cost-benefit score. This combination of concepts was utilized to develop the core of the future implementation strategy of the Plan.

6.3.2 Evaluation Criteria

As mentioned in Step 1 above, evaluation criteria were developed to compare concepts included in the Plan. The purpose of the evaluation criteria is to establish a high-level comparison, ranking, and weighting system for future concepts.

The project evaluation criteria were applied to all of the concepts options. The initial evaluation criteria ideas developed based on similar planning studies were presented in the first Task 5 workshop (consisting of City staff and technical consultants). These initial criteria were then compared with the guiding principles and the LA Basin Stormwater Conservation Study (U.S. Bureau of Reclamation [USBR], 2016). Subsequently, these draft criteria were further refined based on additional input from the Plan project team, LASAN and LADWP management, Advisory Group, stakeholders, and a select group of technical advisors. The criteria are grouped in the following four major categories:

- Economic
- Resiliency
- Implementation
- Environmental

Within each category, criteria were established to characterize the effectiveness of a given concept in meeting that category. Figure 6.3 presents a summary of all 18 evaluation criteria by category and each criteria definition follows. The criteria measurements and scoring guidelines are included in Appendix C of TM 5.1 (see Volume 5).

Economic Criteria	Resiliency Criteria
<ul style="list-style-type: none"> • Unit cost • Financial benefits • Funding mechanism • Likelihood to obtain outside funding 	<ul style="list-style-type: none"> • Drought resiliency • Earthquake resiliency • Flood risk mitigation • Local supply benefit • Energy Impact/Green-House Gas Emissions
Implementation Criteria	Environmental Criteria
<ul style="list-style-type: none"> • Constructability • Institutional collaboration • Regulatory approval • Public engagement • Public and political support 	<ul style="list-style-type: none"> • Environmental justice • Open/natural space and recreational benefit • Stormwater quality • Ecological benefit

Figure 6.3 Evaluation Categories and Criteria

Category – Economic Criteria

As shown on Figure 6.3 and defined in Table 6.1, the economic criteria include: Unit cost, Financial Benefits, Funding Mechanism, and Likelihood to obtain Outside Funding. These economic criteria represent the present and future costs for implementation of a concept, referring to the unit cost per acre-foot (AF) or million gallons of water. It is inclusive of operation and maintenance costs, as well as capital costs, and also considers the economic and financial benefits of a concept. Furthermore, this category accounts for a concept's mutual benefits, relative eligibility and probability for obtaining funding, such as the availability of grants, funding mechanisms, or other methods to fund the concept.

Table 6.1 Economic Criteria Definitions Summary Report One Water LA 2040 Plan	
Criteria	Definition
Unit Cost	<p>Evaluate the unit cost of water supply for the project. It is calculated as:</p> $Unit\ Cost = \frac{Annualized\ Capital\ Cost + Annual\ O\&M\ Cost}{Annual\ Net\ Yield}, \text{ where}$ <p><i>Annual Net Yield = Total Annual Yield – Annual Demand Created.</i></p> <p>The unit cost calculation includes both capital cost and operation & maintenance (O&M) costs. Land acquisition costs are not included. Annual amortized costs are based on typical inflation rates, interest rates, and life expectancies.</p>
Financial Benefits	<p>Evaluate financial merits and financial impacts should the Project be implemented, OR consequences if the Project is not implemented considering opportunity cost, revenue loss, avoidance of repairs, damage/restoration or fine costs.</p>
Project Funding Mechanism	<p>Evaluate the opportunity for the Project to be funded using existing funding mechanisms or structures, creating new funding mechanisms, and the ability to gain sufficient revenue from those mechanisms for funding the Project. New funding mechanisms would include items such as creating a new type of charge (e.g. a stormwater fee, where there is not one already). Existing structures include existing rates or fees.</p>
Likelihood to obtain Outside Funding	<p>Evaluate the opportunity to obtain outside funding based on mutual project benefits aligned with departmental/agency/organizational missions and the portion of the project that could receive outside funding. Outside funding is defined as funds from State, Federal, Regional entities or community grant or low-interest loan programs. (Note: assume outside funding is available).</p>

Category – Resiliency Criteria

As shown on Figure 6.3 and defined in Table 6.2, the resiliency criteria include: Drought Resiliency, Earthquake Resiliency, Flood Risk Mitigation, Local Supply Benefit, and Energy Impact/Greenhouse Gas Emissions. These resiliency criteria are used to characterize the concept's resiliency to drought, earthquakes, floods, fire and landslides, and changes in the climate, as well as its ability to provide a local water supply benefit.

Table 6.2 Resiliency Criteria Definitions Summary Report One Water LA 2040 Plan	
Criteria	Definition
Drought Resiliency	<p>Evaluate the ability for a project/program (Comment: how to represent project vs program throughout criteria) to provide water during a drought. This will be calculated by a ratio between normal and dry year supplies as follows:</p> $\text{Drought resiliency ratio} = \frac{\text{Volume of water available in a dry year}}{\text{Volume of water available in a normal year}}$
Earthquake Resiliency	Evaluate the ability for the project to withstand earthquakes, based on the ability for the project to deliver water after a major earthquake, the duration operation may be interrupted after a major earthquake and the facility type.
Flood Risk Mitigation	Evaluate the ability for the project to mitigate and/or reduce existing flood risk.
Local Supply Benefit	Evaluate the ability for the project to deliver local supplies to the City, offsetting purchased imported water supplies.
Energy Impact/Greenhouse Gas Emissions	Evaluate power consumption, defined as amount of power used per unit of water processed (kWh per acre-foot [AF] of water). The total annual energy consumption per unit of supply is the metric for greenhouse gas emissions and associated climate change impacts. Power can be from a variety of sources with preference to renewable energy.

Category - Implementation Criteria

As shown on Figure 6.3 and defined in Table 6.3, the implementation criteria include: Constructability, Institutional Collaboration, Regulatory Approval, Public Engagement, and Public and Political Support. These implementation criteria consider the concept's constructability; institutional collaboration; regulatory approval, issues, and constraints; public engagement; as well as public and political support.

Table 6.3 Implementation Criteria Definitions Summary Report One Water LA 2040 Plan	
Criteria	Definition
Constructability	Evaluate the ease of constructing the project. Types of major project components that are considered include groundwater injection or extraction wells, pipelines, treatment plants, green infrastructure, habitat restoration, wetlands etc. (Does not include land acquisition).
Institutional Collaboration	The potential to create a framework supporting collaboration on current/future Projects/Programs between City departments, partners, stakeholders and outside agencies OR opportunity for collaboration based on benefits that are aligned with departmental/agency/organizational missions measured by the ability to increase collaboration between City departments, partners, stakeholders and outside agencies (such as Metropolitan Water District [Metropolitan] or METRO).
Regulatory Approval	Evaluate the regulatory approval requirements for the Project. Considers whether existing regulatory framework exists for approving the project, such as California Environmental Quality Act (CEQA) and National Environmental Policy Act (NEPA).
Public Engagement	Evaluate the opportunity for the public to be engaged in and take ownership of the Project/Program from initial project planning through implementation, and after project completion (through presentations, solicitations of input/feedback, ongoing education programs, volunteer opportunities, potential maintenance partnerships, etc.).
Public & Political Support	Level of City Hall, City Council, Commissioners, Mayor's Office, non-governmental organizations (NGOs), Neighborhood Councils, other governmental agencies, and the public or other political stakeholders support, acceptance and willingness to embrace and be involved in the Project.

Category – Environmental Criteria

As shown on Figure 6.3 and defined in Table 6.4, the environmental criteria include: Environmental Justice, Open/Natural Space and Recreational Benefit, Stormwater Quality, and Ecological Benefit. These environmental criteria refer to the ancillary benefits of a concept for the City and its communities, such as environmental justice, open/natural space, recreational benefits, improvement of stormwater quality, as well as ecological impacts/benefits.

Table 6.4 Environmental Criteria Definitions Summary Report One Water LA 2040 Plan	
Criteria	Definition
Environmental Justice	The fair treatment and meaningful involvement of all people in the development and implementation of a project (including the enforcement of environmental laws, regulations, and policies) with the goal of delivering specific benefits to previously underserved communities.
Open/Natural Space and Recreational Benefit	Level to which the project creates locations of open/natural space for recreation. Defined as the amount of open/natural space created. Paved open space is not considered beneficial. Turf is limited to recreational benefits.
Stormwater Quality	The goal is assessing the quality of stormwater and dry water runoff reaching rivers and oceans. This will be calculated by stormwater and dry water runoff volume reduction to meet Total Maximum Daily Load (TMDL) compliance
Ecological Benefit/Habitat Restoration	Degree of the potential ecological benefit, defined by: restoring ecosystems, improving watershed health/ecosystem function/connectivity, minimizing pollutants, improving air quality and reducing heat-island impacts.

6.3.3 Criteria Weighting Factors

In order to establish and allocate relative weights to the 18 evaluation criteria, a paired comparison exercise was conducted. This exercise was conducted with the project team and the Advisory Group. In addition, input on the relative importance of the 18 criteria was obtained through an interactive exercise in a stakeholder workshop as well as a survey, where each of the criteria was ranked against each other (paired comparison). Details of the paired comparison exercise, including the scoring sheets, are included in Appendix E of TM 5.1 (see Volume 5), while the weighting factor results are graphically depicted from highest to lowest ranked on Figure 6.4.

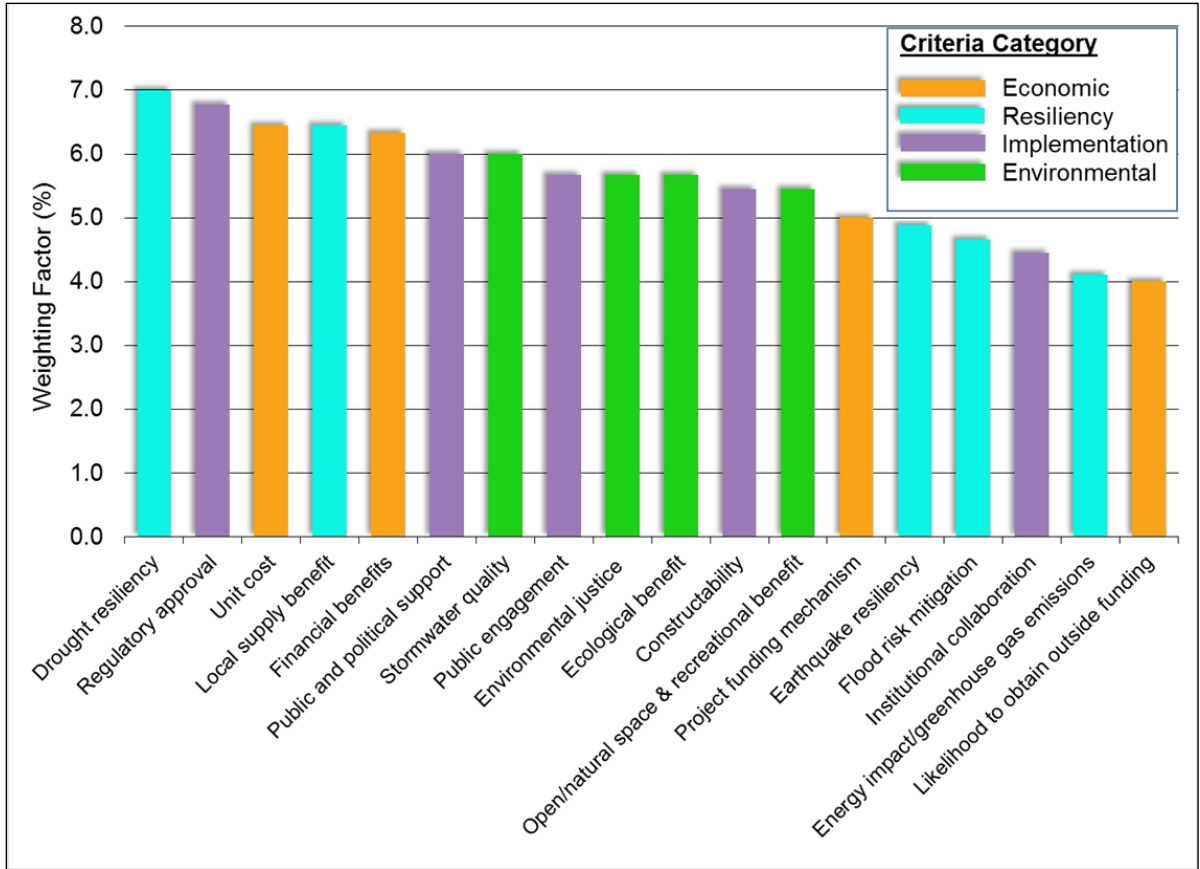

Figure 6.4 Concept Criteria Weighting Factors

As shown on Figure 6.4, the calculated relative weights of each of the 18 criteria ranges from 3.7 percent (Likelihood to obtain Outside Funding) to 6.4 percent (Drought Resiliency). This equates to a variance of -27 percent to +28 percent compared to the average weight of 5.0 percent per criterion. It can also be observed that there is no correlation between the weighting score and the criteria category, as all categories are distributed throughout the spectrum of scores. All major categories have an equal average weight, and concept scores were, therefore, based on the individual criterion only.

The three highest scored criteria are Drought Resiliency, Regulatory Approval, and Local Supply Benefit. These criteria align strongly with the major water challenges facing the City. Concepts that address these challenges and provide local supply benefits during droughts and/or contribute to regulatory approval and stormwater quality, such as total maximum daily load (TMDL) deadlines, were, therefore, given a higher weight in the project scoring.

6.4 CONCEPT OPTIONS

Concept options include local water supply, water quality, and flow management opportunities that could potentially be implemented as part of a future strategy. Concept options are primarily new ideas that have not been previously evaluated by the City in other planning documents. A total of 27 concept options were developed as part of the One Water LA 2040 Plan to provide a valuable initial analysis to inform future decision-making. The various City departments and regional agencies identified to lead or support these concept options will need to work together to further evaluate and assess the feasibility of each concept option prior to implementation.

The purpose of the future integration opportunities evaluation is to assess the benefits and estimated costs of these concept options. The 27 concept options were evaluated on a relative comparison basis. Also, some additional project ideas were provided by stakeholders (see meeting materials in Volume 9). The most viable concepts are included in the Plan's trigger-based Implementation Strategy (see Chapter 9).

The concept options are listed in Table 6.5, while the approximate water routing and project locations are depicted on Figure 6.5. In addition, a brief description of each concept option and an illustrated conceptual process flow schematic is provided in Appendix B of the Summary Report. The assumptions used to estimate the yield of each concept, size infrastructure, and prepare cost estimates, are included in TM 5.2 (see Volume 5).

As shown in Table 6.5, the concept options can be grouped into the nine strategies described in Section 6.2, with the following two exceptions.

1. The centralized stormwater projects, described in Section 6.5.1.1 and in more detail in TM 5.2 (see Volume 5), were already defined in the EWMPs and are already included in the In-Progress and Planned projects. These projects were therefore not included as a separate concept option.
2. The potable reuse concepts were separated into three categories to clearly differentiate between potable reuse with raw or treated water augmentation. It should be noted that potable reuse with groundwater augmentation is referred to as indirect potable reuse (IPR) in the supporting technical memorandums. Similarly, potable reuse with raw water or treated water augmentation is collectively referred to as direct potable reuse (DPR) in the supporting technical memorandums.

Table 6.5 List of Concept Options Summary Report One Water LA 2040 Plan			
Future Integration Strategy	Concept ID#	Concept Name	Estimated Yield (AFY)
Distributed Stormwater BMPs	1	Green Streets – Upper Los Angeles River Watershed	11,900 ⁽¹⁾
	2	Green Streets – Ballona Creek Watershed	2,300 ⁽⁴⁾
	3	Green Streets – Dominguez Channel Watershed	2,600 ⁽⁴⁾
	4	Green Streets – Santa Monica Bay/Marina del Rey Watersheds	460 ⁽¹⁾
LA River Storage and Use	7	Upper Los Angeles River to Tillman WRP	5,600
	8A	LA River Recharge into LA Forebay using Injection Wells	25,000
	8B	LA River Recharge into LA Forebay using Dry Wells	25,000
Potable Reuse with Groundwater Augmentation	9	Tillman WRP to San Fernando Basin Injection Wells	15,000
	10	Hyperion WRP to West Coast Basin Injection Wells	20,000
	11	Hyperion WRP to Central Basin Injection Wells	75,000
	12	Hyperion WRP to Central Basin with Spreading Basins	95,000
	13	MBR at Hyperion WRP to Regional System	95,000
	14	Hyperion WRP to San Fernando Basin Injection Wells	20,000
Potable Reuse with Raw Water Augmentation	15	Tillman WRP to Los Angeles Aqueduct Filtration Plant	15,000
	20	Hyperion WRP to Los Angeles Aqueduct Filtration Plant	95,000
	21	Central LA Satellite WRP to Los Angeles Aqueduct Filtration Plant	95,000
Potable Reuse with Treated Water Augmentation	16	Tillman WRP to LADWP Distribution System	15,000
	17	LA/Glendale (LAG) WRP to Headworks Reservoir	6,000
	18	Hyperion WRP to LADWP Distribution System	95,000
	19	Hyperion WRP to Headworks Reservoir	95,000
Non-Potable Reuse	23	Increase Recycled Water Demand beyond 2015 UWMP	16,700
	24	Rancho Park Water Reclamation Facility	3,600
Desalination	25	Ocean Desalination	28,000
Flow Management ⁽²⁾	5	Dry Weather Low Flow Diversions	6,200
	6	Wet Weather Flow Diversions	1,000
	22	East-West Valley Interceptor Sewer	n/a ⁽³⁾
	26	Japanese Garden and Sepulveda Basin Lakes Recirculation	20,000
Notes:			
(1) It is estimated that the total citywide water supply benefit of the stormwater program (including Green Streets) is approximately 110,000 AFY under normal-year conditions. These numbers will vary greatly depending on hydrologic conditions and sequencing of storm events.			
(2) Flow management concepts are not a strategy, but rather prerequisite concepts for other potable reuse concepts. Concept Options #5 and #6 also provide stormwater quality benefits. Concept Options #22 and #26 provide a flow increase to DCTWRP due to rerouting of flows.			
(3) The EWWIS does not provide new supply yield. EWWIS has an estimated conveyance capacity of 11.4 mgd to reroute and increase flows to Donald C. Tillman WRP to maximize reuse opportunities from this facility.			

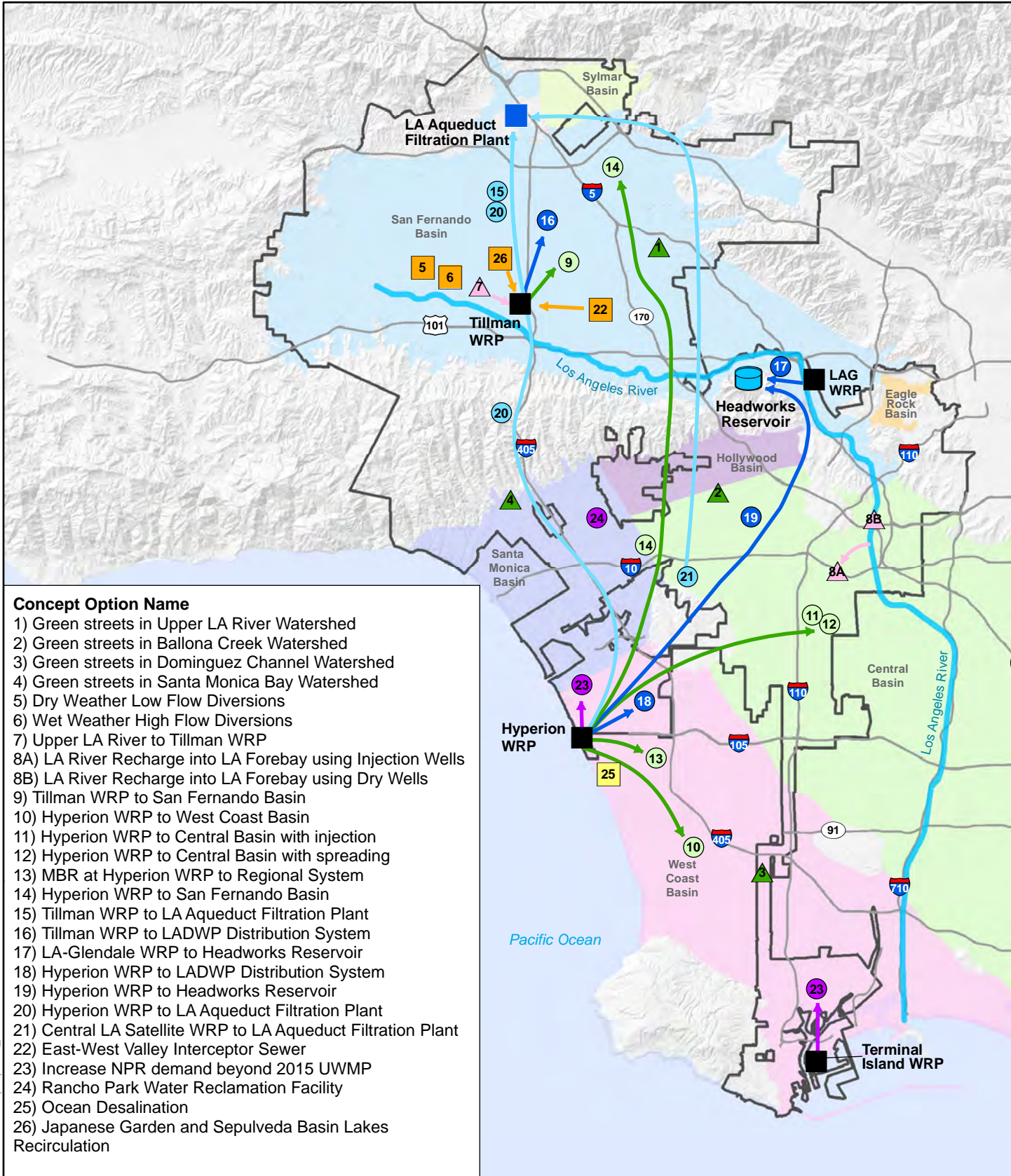

Concept Option Name

- 1) Green streets in Upper LA River Watershed
- 2) Green streets in Ballona Creek Watershed
- 3) Green streets in Dominguez Channel Watershed
- 4) Green streets in Santa Monica Bay Watershed
- 5) Dry Weather Low Flow Diversions
- 6) Wet Weather High Flow Diversions
- 7) Upper LA River to Tillman WRP
- 8A) LA River Recharge into LA Forebay using Injection Wells
- 8B) LA River Recharge into LA Forebay using Dry Wells
- 9) Tillman WRP to San Fernando Basin
- 10) Hyperion WRP to West Coast Basin
- 11) Hyperion WRP to Central Basin with injection
- 12) Hyperion WRP to Central Basin with spreading
- 13) MBR at Hyperion WRP to Regional System
- 14) Hyperion WRP to San Fernando Basin
- 15) Tillman WRP to LA Aqueduct Filtration Plant
- 16) Tillman WRP to LADWP Distribution System
- 17) LA-Glendale WRP to Headworks Reservoir
- 18) Hyperion WRP to LADWP Distribution System
- 19) Hyperion WRP to Headworks Reservoir
- 20) Hyperion WRP to LA Aqueduct Filtration Plant
- 21) Central LA Satellite WRP to LA Aqueduct Filtration Plant
- 22) East-West Valley Interceptor Sewer
- 23) Increase NPR demand beyond 2015 UWMP
- 24) Rancho Park Water Reclamation Facility
- 25) Ocean Desalination
- 26) Japanese Garden and Sepulveda Basin Lakes Recirculation

Legend

Existing Water Reclamation Plant (WRP)	City of Los Angeles	LA River Storage and Use
Existing Reservoir	Strategy Category	Flow Management
Existing Water Filtration Plant	Non-Potable Reuse	Already Proposed Stormwater Management Projects
Groundwater Basin Source: LACDPW	Potable Reuse with Groundwater Augmentation	Ocean Desal Plant
	Potable Reuse with Raw Water Augmentation	
	Potable Reuse with Treated Water Augmentation	
		Hillshade Source: CalAtlas http://www.atlas.ca.gov

Figure 6.5 - Concept Options Overview Map
 One Water LA 2040 Plan Summary Report

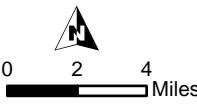

Document Path: E:\JACKIEBKU\UO\WLA\MXD\ConceptOptions_TM52.mxd



6.4.1 Concept Scoring Process

Each concept option was scored utilizing the concept description sheets and the evaluation criteria metrics presented in Appendix C of TM 5.1 (see Volume 5). A group of LASAN, LADWP, and Consultant staff scored each of the various concepts by the criteria in a workshop/collaborative setting. Based on the scores, a weighted project score was calculated for each concept.

It should be noted that only 25 concept options were scored during this comprehensive process as Concept Option #8B and Concept Option #26 were developed after the scoring exercise was completed.

The scored concepts were combined into themed portfolios. Once grouped into portfolios, an overall cost-benefit ratio could be developed for each portfolio. Upon evaluation of the themed portfolios, concepts with lower scores could be eliminated from further evaluation as part of the Plan, and concepts with higher scores could be combined to build preferred portfolio options.

6.4.1.1 Concept Options Evaluation Results

Yield and Cost

As shown in Table 6.5, the estimated yield of the 27 concept options ranges from 1,000 to 95,000 AFY. It is important to note that the listed yield does not reflect new supply yield for all concepts, and that the majority of stormwater concepts are primarily intended to meet water quality objectives, although many projects will also provide local supply benefit. In addition, flow management options do not provide a new yield as a standalone project, but only in combination with the non-potable and/or potable reuse concepts.

Hence, the unit supply cost is not an equal metric for all concept options. However, as unit costs expressed in dollar per acre-foot (\$/AF) is such a common benchmark, a unit cost was calculated for all 27 concept options. The unit cost includes a combination of amortized capital cost as well as operations and maintenance (O&M) cost, including energy required to treat, convey, inject, and extract water, as needed.

As shown, the calculated unit costs range from just under \$500/AF (Concept Option #7) to more than \$27,000/AF (Concept Option #4). The yield-weighted unit costs of the concepts are graphically depicted on Figure 6.6.

Figure 6.6 shows the yield-weighted unit cost for each concept option, colored by strategy. Collectively, the distributed stormwater BMP concepts have the highest yield-weighted unit cost, with Concept Options #2 and #4 clearly exceeding the yield-weighted unit cost of all other concept options due to the low supply yield that these options would provide, as the key benefits of these concepts are related to stormwater and receiving water quality.

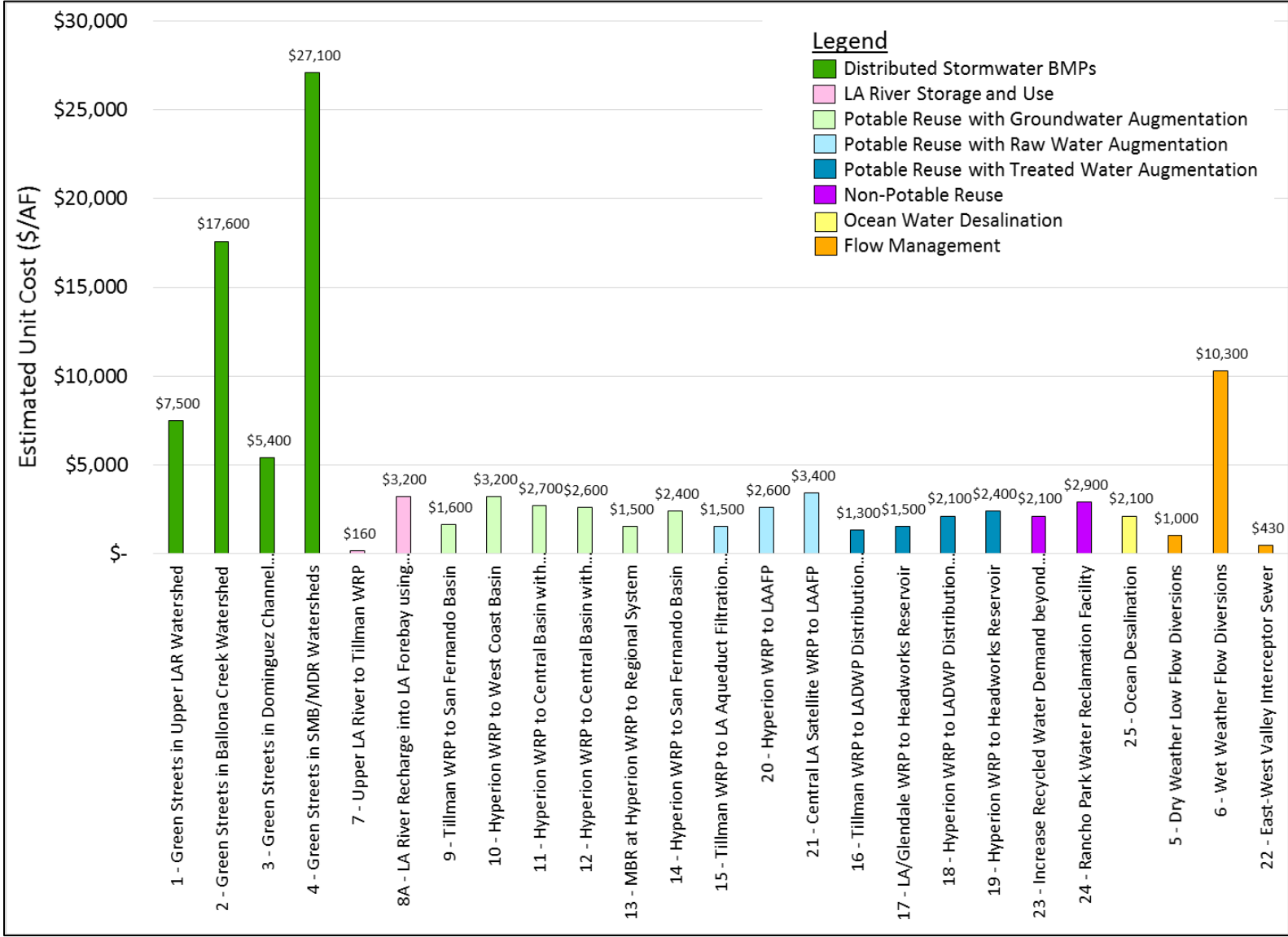

Figure 6.6 Yield-weighted Unit Costs by Concept and Strategy

The yield-weighted unit costs of the six Potable Reuse with Groundwater Augmentation concepts range from \$1,500/AF (Concept Option #13) to \$3,200/AF (Concept Option #10). The yield-weighted unit costs of the Potable Reuse with Raw Water Augmentation concepts have more of a spread, ranging from \$1,500/AF (Concept Option #15) to \$3,400/AF (Concept Option #21). Whereas, the yield-weighted unit costs of the Potable Reuse with Treated Water Augmentation concepts have less of a spread, ranging from \$1,300/AF (Concept Option #16) to \$2,400/AF (Concept Option #19).

Generally, the higher cost options involve substantially more conveyance infrastructure than the lowest-cost treated water augmentation option, which would consist of delivery of advanced treated water into the potable water distribution system via an engineered storage buffer which is contingent on approval of potable reuse regulations. Lastly, the yield-weighted unit cost of the other strategies, also range widely from \$600/AF (Concept Option #22) to \$2,900/AF (Concept Option #24). It is interesting to note that the yield-weighted unit cost of additional non-potable reuse expansions and ocean desalination are roughly the same.

Benefits Scoring Results

Some of the concepts provide stormwater and receiving water quality benefits or local water supply benefits, while other concepts provide flow management benefits, but do not provide a direct water supply benefit without the implementation of other concepts.

The benefit of the flow management concept options is to increase flows, specifically to DCTWRP to potentially implement additional potable reuse concepts. These flow management concepts are, therefore, not a standalone strategy, but rather a prerequisite concept for other potable reuse concepts. It should be noted that Concept Options #5 and #6 (Dry and Wet Weather Flow Diversions) are not only flow management strategies that could increase flows to DCTWRP, but also provide stormwater quality benefits by capture of flows upstream in the watershed.

The total weighted score of all concepts sorted by rank is presented on Figure 6.7. The total rank presents the aggregate score of all 18 evaluation criteria listed on Figure 6.3. There are two key observations that can be made. First, the concept option scores are relatively close to each other due to the wide variety of criteria that were used. For example, some concepts had higher environmental scores, while others scored higher on the economic, resiliency, or implementation criteria. Second, the weighting factors did not significantly change the scoring of the concept options. The concept options with the highest rankings in certain criteria were combined and used to develop portfolios.

As shown on Figure 6.7, the highest-ranked concept options are the Green Streets concepts (Concept Options #1 through #4) and HWRP to Regional System (Concept Option #13). The two lowest-ranked concept options are Ocean Desalination (Concept Option #25) and Potable Reuse with Treated Water Augmentation from a New Satellite WRP to LAAFP (Concept Option #21).

These two lowest-scoring concept options were not included for consideration in the portfolio evaluation. In addition, Concept Option #12 (Potable Reuse with Groundwater Augmentation from HWRP to Spreading Basins in the Central Basin) was eliminated due to the lack of open space to create new recharge facilities, which was considered as a fatal flaw.

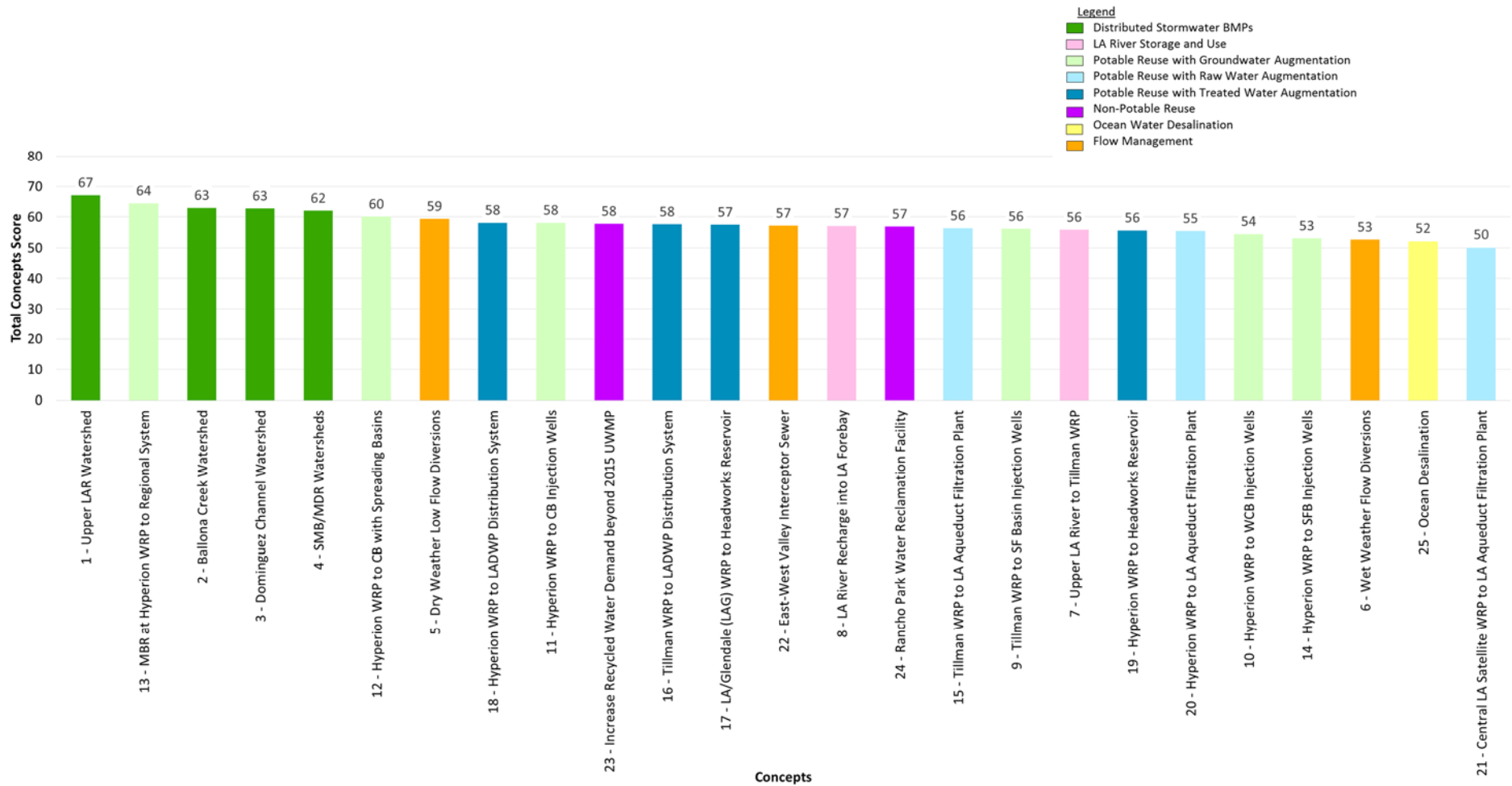

Figure 6.7 - Concept Options Weighted Scores by Rank
 One Water LA 2040 Plan
 Summary Report

6.5 PORTFOLIO EVALUATION

A total of six portfolios were developed, including one benchmark portfolio, four themed portfolios, and one preferred portfolio. The benchmark portfolio reflects the supply mix changes as presented in the 2015 UWMP, as well as some other in-progress and planned stormwater projects described in Section 6.5.1.1. The remaining four portfolios were arranged around themes that emphasize the following strategies to assess the sensitivity of extremes:

- Portfolio 1: Minimize Cost
- Portfolio 2: Maximize Environmental Benefits
- Portfolio 3: Maximize Institutional Collaboration
- Portfolio 4: Maximize Local Water Supplies.

Portfolio themes were established as a result of key questions asked by City staff and stakeholders. The following key questions are illustrated on Figure 6.8, while the definitions of each portfolio are summarized in Table 6.6.

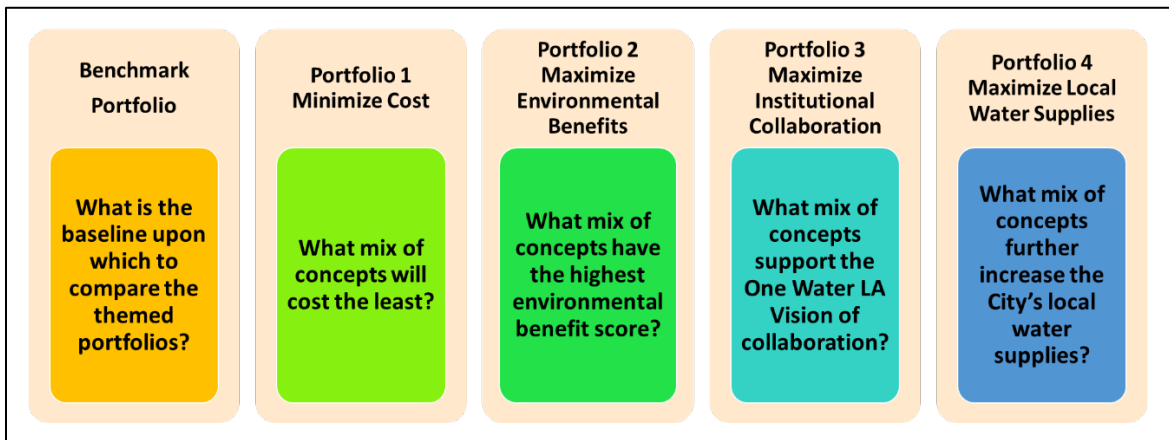

Figure 6.8 Establishing Portfolio Themes

The purpose of the portfolio evaluation is to analyze trade-offs when implementing concept options that are selected based on the identified themes. In other words, it provides a sensitivity analysis of extremes. The portfolios are, therefore, not intended to be an alternative that should be implemented as a group of projects without further consideration. Instead, the results of the portfolio evaluation were used to develop a more balanced approach that accomplishes multiple goals by grouping the most beneficial concept options of each portfolio in a preferred portfolio.

Table 6.6 Portfolio Definitions Summary Report One Water LA 2040 Plan	
Portfolio Title	Portfolio Definition
Benchmark Portfolio	<p>Scenario to simulate no further action or implementation of the future Concept Options presented in TM 5.2. The Benchmark Portfolio includes:</p> <ul style="list-style-type: none"> • Existing supply sources • In-Progress Projects and Programs • Planned Stormwater Management Projects <p>Note: Planned stormwater management projects include all projects in the Stormwater and Urban Runoff Facilities Plan required to meet MS4 Permit Compliance.</p>
Portfolio 1 - Minimize Cost	<p>Scenario to simulate the tradeoff if only the most cost-effective Concept Options are implemented. A threshold of \$2,000/AF was used for Concept Options with new supply benefits (excluding flow management concepts).</p>
Portfolio 2 - Maximize Environmental Benefits	<p>Scenario to simulate the tradeoff if all of the Concept Options with the most environmental benefits were implemented. All Concept Options with a combined environmental benefit score of about 12 or more (out of 20) were included in this portfolio.</p>
Portfolio 3 -Maximize Institutional Collaboration	<p>Scenario to simulate the tradeoff if the most collaborative Concept Options were implemented, increasing coordination (and potentially cost savings) between City departments, partners, stakeholders, and outside agencies. All Concept Options with an institutional collaboration score of 3.0 or greater (out of 5) were included in this portfolio.</p>
Portfolio 4 - Maximize Local Supplies	<p>Scenario to simulate the tradeoff if only Concept Options that maximize local supply were implemented, increasing local water supplies, and reducing dependence on purchased imported water supplies. The most cost-effective local supply Concept Options was included from each supply source to avoid double counting of supplies.</p>
Preferred Portfolio	<p>Based on the results of the four extreme portfolios and discussions with City staff, the preferred portfolio was compiled. The preferred portfolio consists of the most beneficial concept options considering a wide range of benefits and availability of water from the various potential sources including recycled water, stormwater, and dry weather runoff.</p>

The results of the portfolio sensitivity analysis exercise were used to develop the preferred portfolio as illustrated on Figure 6.9.

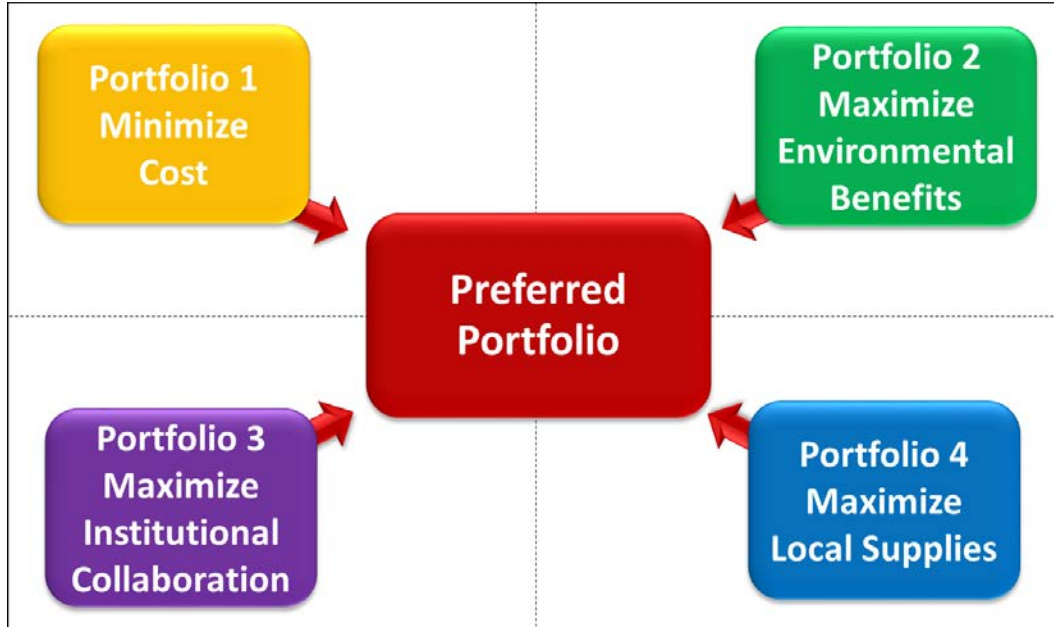

Figure 6.9 Portfolio Sensitivity Analysis Process

The concept options that were included in each of the four themed and preferred portfolio are summarized in Table 6.7.

As shown in Table 6.7, some concept options are included in multiple portfolios while other options are not included in any portfolios. It should be noted that some of the concept options that are currently not included in the Preferred Portfolio remain good viable alternatives in case certain triggers do not materialize. A detailed discussion on triggers and implementation strategy are included in Chapter 9. Brief descriptions of the concept options along with a flow schematic can be found in Appendix B of the summary report, while detailed descriptions, assumptions, and maps are included in TM 5.2 (see Volume 5).

Two of the concept options listed in Table 6.7 were eliminated before the portfolio development compilation for the reasons provided below:

- Concept Option #12 - Potable Reuse with Groundwater Augmentation from Hyperion via Spreading Basins in the Central Basin. This option was eliminated in a fatal flaw analysis due to insufficient open space to construct new spreading basins.
- Concept Option #24 - Rancho Park Water Reclamation Facility. This option was excluded as it is already categorized as a current integration opportunity.

#(1,2)	Concept Option Name	Benchmark Portfolio	Portfolio 1 Minimize Cost	Portfolio 2 Max. Env. Benefits	Portfolio 3 Max. Inst. Collaboration	Portfolio 4 Max. Local Supplies	Preferred Portfolio
1	Green Streets – Upper Los Angeles River Watershed	X	X	X	X	X	X
2	Green Streets – Ballona Creek Watershed	X	X	X	X	X	X
3	Green Streets – Dominguez Channel Watershed	X	X	X	X	X	X
4	Green Streets – Santa Monica Bay/Marina Del Rey Watersheds	X	X	X	X	X	X
5	Dry Weather Low Flow Diversions		X	X		X	X
6	Wet Weather Flow Diversions			X		X	
7	Upper Los Angeles River to Tillman WRP		X				
8A	LA River Recharge into LA Forebay using Injection Wells			X	X	X	X
8B	LA River Recharge into LA Forebay using Dry Wells ⁽²⁾						
9	Tillman WRP to San Fernando Basin Injection Wells						
10	Hyperion WRP to West Coast Basin Injection Wells						
11	Hyperion WRP to Central Basin Injection Wells				X		
13	MBR at Hyperion WRP to Regional System		X	X		X	X
14	Hyperion WRP to San Fernando Basin Injection Wells						
15	Tillman WRP to Los Angeles Aqueduct Filtration Plant					X	X
16	Tillman WRP to LADWP Distribution System		X				
17	LA/Glendale WRP to Headworks Reservoir		X			X	X
18	Hyperion WRP to LADWP Distribution System						
19	Hyperion WRP to Headworks Reservoir						
20	Hyperion WRP to Los Angeles Aqueduct Filtration Plant						
21	Central LA Satellite WRP to Los Angeles Aqueduct Filtration Plant						
22	East-West Valley Interceptor Sewer		X			X	X
23	Increase Recycled Water Demand beyond 2015 UWMP				X	X	
25	Ocean Desalination						
26	Japanese Garden and Sepulveda Basin Lakes Recirculation ⁽¹⁾						
Notes:							
(1) Concept Option #12 (Hyperion WRP to Central Basin with spreading basins) was removed as the lack of open space to create recharge sites was considered a fatal flaw. Concept Option #24 (Rancho Park Water Reclamation Facility) was removed as it is already categorized as a current integration opportunity.							
(2) Concept Option #8B and Concept Option #26 were not included in the initial portfolios because these concepts were developed at a later planning stage.							

Two of the concept options listed in Table 6.7 were added after the portfolio development compilation for the reasons provided below:

- Concept Option #8B - LA River Recharge into LA Forebay using Dry Wells. This option was added based on discussions with City staff and outside stakeholders after the concept scoring workshop.
- Concept Option #26 - Japanese Garden and Sepulveda Basin Lakes Recirculation. This option was added based on discussions with City staff to provide an alternative or additional strategy to increase flows for potable reuse from DCTWRP. This concept was also developed after the concept scoring workshop.

6.5.1 Portfolio Descriptions

The following sections briefly summarize the components in the Benchmark Portfolios as well as the four Themed Portfolios.

6.5.1.1 Benchmark Portfolio

The Benchmark Portfolio is a scenario to simulate future conditions from projects and programs that are either already in-progress or planned. The Benchmark Portfolio includes the following three major components:

- Existing Supply Sources
- In-Progress Projects and Programs (as of November 2016)
- Planned Stormwater Management Projects

The Benchmark Portfolio is the foundation upon which the themed portfolio analysis is built, as illustrated on Figure 6.10. The purpose of the Benchmark Portfolio is to provide a comparison basis for the other themed portfolios as shown on Figure 6.10. The Benchmark Portfolio includes projects and programs that are already in-progress or planned to be implemented by the City. It does not include any of the Concept Options developed as part of the One Water LA effort, with the exception of Concept Options #1 through #4 because the Green Street programs were already identified in the EWMPs as necessary to meet TMDL requirements.

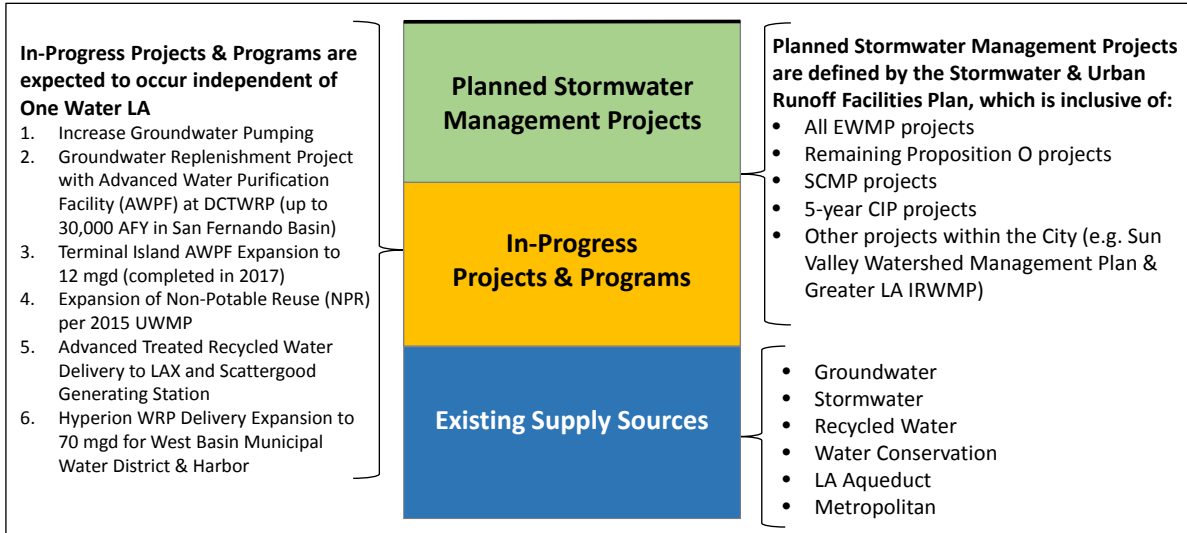

Figure 6.10 Benchmark Portfolio Components

In-Progress Projects and Programs

In-Progress Projects and Programs are planned projects or programs for potable reuse, non-potable reuse, regional or centralized stormwater, and distributed stormwater that are expected to be implemented independent of the Plan. These projects are already defined in other completed planning efforts and are assumed to be moving forward as of November 2016. The projects are at various stages of implementation, and may or may not be funded, have completed environmental documentation, or be included in existing Capital Improvement Plans (CIPs). Some In-Progress Projects and Programs are already in the design or construction phase, and may have been completed.

The In-Progress Projects and Programs roll up into two future integration strategies:

- Non-Potable Reuse
- Potable Reuse with Groundwater Augmentation

A summary of the In-Progress Projects and Programs is provided in Table 6.8, while high-level descriptions of the In-Progress Projects and Programs are provided in Appendix B of TM 5.2 (see Volume 5).

Table 6.8 In-Progress Projects and Programs Summary Report One Water LA 2040 Plan		
Strategy	#	In-Progress Project or Program
Potable Reuse Groundwater Augmentation	1	Increase Groundwater Pumping
	2	Groundwater Replenishment Project with Advanced Water Purification Facility (AWPF) at DCTWRP (up to 30,000 AFY in San Fernando Basin)
Non-Potable Reuse	3	Terminal Island AWPF Expansion to 12 mgd (completed in 2017)
	4	Expansion of Non-Potable Reuse (NPR) per 2015 Urban Water Management Plan
	5	Advanced Treated Recycled Water Delivery to LAX and Scattergood Generating Station
	6	HWRP Delivery Expansion to 70 mgd for West Basin Municipal Water District and LA Harbor Area

Planned Stormwater Management Projects

The Stormwater and Urban Runoff Facilities Plan includes more than 1,200 centralized and distributed stormwater project opportunities in a stormwater database. The projects have been aggregated from the EWMPs, LADWP's SCMP, remaining Prop O projects, and other five-year CIP projects as required to meet MS4 Permit Compliance. A complete listing of the planned stormwater management projects is included in the Stormwater and Urban Runoff Facilities Plan (see Volume 3). The list of projects also includes all Green Streets projects in each of the City's four major watersheds (see Concept Options 1 through 4 in Section 6.4).

The City is already committed to implement these Green Streets programs because these distributed projects are needed to help meet the TMDL compliance targets described in the EWMPs and Stormwater and Urban Runoff Facilities Plan. Hence, these planned projects are included in all portfolios, including the benchmark portfolios. By including the entire planning level estimated cost of the stormwater program (\$5.6 billion) in all portfolios, the benchmark portfolio provides an equal basis for a relative comparison between the Benchmark Portfolio and Themed Portfolios (with and without the concept options).

The Stormwater Management Projects roll up into two future integration strategies:

- Distributed Stormwater BMPs
- Regional or Centralized Stormwater BMPs

A summary of the Planned Stormwater Management Projects is provided in Table 6.9, while high-level descriptions of the Planned Stormwater Management Projects were obtained from the Stormwater and Urban Runoff Facilities Plan (see Volume 3).

Table 6.9 Planned Stormwater Management Projects Summary Report One Water LA 2040 Plan		
Strategy	#	Planned Stormwater Management Projects ⁽⁴⁾
Regional or Centralized Stormwater BMPs	1	Upper LA River Watershed EWMP, SCMP, Prop O
	2	Ballona Creek Watershed EWMP, SCMP, Prop O
	3	Dominguez Channel Watershed EWMP, SCMP, Prop O
	4	Santa Monica Bay/Marina del Rey Watersheds EWMP, SCMP, Prop O
	5	Other Planned Stormwater Management Projects within the City(e.g., Sun Valley Watershed Management Plan & Greater LA Integrated Regional Water Management Plan [IRWMP])
<p><u>Note:</u> (1) More than 1,200 individual stormwater and urban runoff projects are documented in the Stormwater and Urban Runoff Facilities Plan (see Volume 3). For the purpose of this analysis, the stormwater projects are grouped by watershed, similar to the EWMPs.</p>		

6.5.1.2 Portfolio 1 - Minimize Cost

The purpose of this scenario is to simulate future conditions with concept options that have the lowest yield-weighted unit cost, along with the project components included in the Benchmark Portfolio. As listed in Table 6.7, this portfolio includes the following concept options:

- Concept Option #5 - Dry Weather Low Flow Diversions
- Concept Option #7 - Upper LA River to DCTWRP to Increase Flows to DCTWRP for Concept Option #16
- Concept Option #13 - Potable Reuse from HWRP to Regional System
- Concept Option #16 - Potable Reuse with Treated Water Augmentation from DCTWRP to LADWP's Distribution System
- Concept Option #17 - Potable Reuse with Treated Water Augmentation from LAGWRP to Headworks Reservoirs (LADWP's distribution system)
- Concept Option #22 - East-West Valley Interceptor Sewer (EWVIS) to Increase Flows to DCTWRP for Concept Option #16

The combined new supply yield of these concept options is up to 127,800 AFY, assuming full utilization of all concept options under all hydrologic conditions. The total estimated capital cost of the concept options included in Portfolio 1 is estimated to cost the City an additional \$1.2 billion, on top of the \$8.2 billion Benchmark Portfolio, for a total estimated capital cost of \$9.7 billion. This equates to a yield-weighted unit cost of roughly \$2,100/AF.

6.5.1.3 Portfolio 2 – Maximize Environmental Benefits

The purpose of this scenario is to simulate future conditions with concept options that have the highest environmental benefit scores, along with the project components included in the Benchmark Portfolio. As listed in Table 6.7, this portfolio includes the following concept options:

- Concept Option #5 – Dry Weather Low Flow Diversions
- Concept Option #6 – Wet Weather Flow Diversions
- Concept Option #8A – LA River Recharge into LA Forebay using Injection Wells
- Concept Option #13 – Potable Reuse from HWRP to Regional System

The combined new supply yield of these concept options is up to 127,200 AFY, assuming full utilization of all concept options under all hydrologic conditions. The total estimated capital cost of the concept options included in Portfolio is estimated to cost the City an additional \$2.1 billion, on top of the \$8.2 billion Benchmark Portfolio, for a total estimated capital cost of \$10.3 billion. This equates to a yield-weighted unit cost of roughly \$2,200/AF.

6.5.1.4 Portfolio 3 - Maximize Institutional Collaboration

The purpose of this scenario is to simulate future conditions with concept options that have the highest institutional collaboration benefit scores, along with the project components included in the Benchmark Portfolio. As listed in Table 6.7, this portfolio includes the following concept options:

- Concept Option #8A - LA River Recharge into LA Forebay using Injection Wells
- Concept Option #11 - Potable Reuse with Groundwater Augmentation from HWRP to Central Basin with Injection Wells
- Concept Option #23 - Increase Recycled Water Demand Beyond the Projections of the 2015 UWMP

The combined new supply yield of these concept options is up to 106,600 AFY, assuming full utilization of all concept options under all hydrologic conditions. The total estimated capital cost of the concept options included in Portfolio 3 is estimated to cost the City an additional \$4.6 billion, on top of the \$8.2 billion Benchmark Portfolio, for a total estimated capital cost of \$12.8 billion. This equates to a yield-weighted unit cost of roughly \$2,400/AF.

6.5.1.5 Portfolio 4 - Maximize Local Water Supplies

The purpose of this scenario is to simulate future conditions with concept options that have the lowest yield-weighted unit cost, along with the project components included in the Benchmark Portfolio. As listed in Table 6.7, this portfolio includes the following concept options:

- Concept Option #5 - Dry Weather Low Flow Diversions
- Concept Option #6 - Wet Weather Flow Diversions
- Concept Option #8A - LA River Recharge into LA Forebay using Injection Wells
- Concept Option #13 - Potable Reuse from HWRP to Regional System

- Concept Option #15 - Potable Reuse with Raw Water Augmentation from DCTWRP to the LA Aqueduct Filtration Plant
- Concept Option #17 - Potable Reuse with Treated Water Augmentation from LAGWRP to Headworks Reservoirs (LADWP's distribution system)
- Concept Option #22 - East-West Valley Interceptor Sewer (EWWIS) to Increase Flows to DCTWRP for Concept Option #15
- Concept Option #23 - Increase Recycled Water Demand Beyond the projections of the 2015 UWMP

The combined new supply yield of these concept options is up to 154,800 AFY, assuming full utilization of all concept options under all hydrologic conditions. The total estimated capital cost of the concept options included in Portfolio 4 is estimated to cost the City an additional \$3.0 billion, on top of the \$8.2 billion Benchmark Portfolio, for a total estimated capital cost of \$12.2 billion. This equates to a yield-weighted unit cost of roughly \$2,200/AF.

6.5.2 Portfolio Evaluation Criteria

To compare the results of the portfolio evaluation, a variety of metrics were defined that capture the wide range of factors to be considered for developing a balanced long-term implementation strategy. The evaluation metrics are summarized in Table 6.10, while detailed descriptions of the criteria and metrics are included in TM 5.1 (see Volume 5).

Table 6.10 Evaluation Metrics Summary Summary Report One Water LA 2040 Plan	
Category	Metrics
Yield	<ul style="list-style-type: none"> • New Yield
Cost	<ul style="list-style-type: none"> • Capital Cost • Annual O&M Cost • Unit Cost
Flow Balance	<ul style="list-style-type: none"> • Water Recycling Flow (AFY) • Water Recycling Ratio (%) • Stormwater Recharge (AFY) • DCT and LAG Discharges to LA River (mgd) • Ocean Discharge (AFY)
Environmental Benefits	<ul style="list-style-type: none"> • Environmental Benefit Score • Energy Footprint
Sustainable City pLAN goals	<ul style="list-style-type: none"> • Stormwater Quality Grade-Point Average (GPA) • Stormwater Capture (AFY) • Reduction in Purchased Imported Water (%) • Local Water Supply (%)
<u>Note:</u>	
(1) Detailed definitions of the evaluation criteria and metrics are included in TM 5.1 (see Volume 5)	

6.5.3 Portfolio Evaluation Results

The flow balance metrics were obtained from the MBT runs conducted under normal-, wet-, and dry-year hydrologic conditions. These criteria, along with the portfolio evaluation results, are discussed in detail in TM 5.3 (see Volume 5) and are briefly summarized below:

- The amount of water recycling does not increase substantially for any of the portfolios (from 30 percent to 30-32 percent) during normal years because the City does not purchase much imported water that can be offset with the new local supplies generated by the various concept options.
- The amount of water recycling does increase substantially in all portfolios (from 31 percent to 50-58 percent) during dry years because the City has planned to purchase more than 300,000 AFY of imported water due to lower LAA deliveries, which can be offset with the new local supplies generated by the various concept options included in the portfolios.
- The amount of stormwater recharge is the same for all portfolios. However, the amount of stormwater capture is higher in the portfolios including the low flow and high flow diversions (Concept Options #5 and #6). Naturally, both capture and recharge are estimated to be the highest under wet-year conditions and the lowest under dry-year conditions.
- The environmental benefit score is the highest in the Benchmark Portfolio because it is based on the average score of Concept Options #1 through #4 (Green Streets in all four watersheds), which have the highest environmental justice, open/natural space and recreation, stormwater quality, and ecological benefits of all 27 concept options. When more concept options are added in the other portfolios, the average score decreases automatically.
- The energy footprint of the portfolios is generally lower than the Benchmark Portfolio due to the increase of potable reuse concepts, which have a lower energy usage than purchased imported water when considering the high energy for long-distance conveyance.
- The Sustainable City pLAN goal to achieve 150,000 AFY of stormwater capture is nearly met by the Benchmark Portfolio and Portfolio 3. Due to the addition of Concept Option #5 (Dry Weather Low Flow Diversions) and Concept Option #6 (Wet Weather Flow Diversions), the goal is exceeded in Portfolios 1, 2, 4, and the preferred portfolio under normal-year conditions. Due to less rainfall, the goal is not met for any portfolio under dry-year conditions.
- The Sustainable City pLAN goal to reduce purchased imported water by 50 percent is met under normal conditions in the Benchmark Portfolio and is only reduced by 30 percent under dry-year conditions. This goal is generally met under both normal- and dry-year conditions for all other portfolios.
- The Sustainable City pLAN goal to source 50 percent of the City's water supply locally is met under normal- and dry-year conditions in all portfolios. Although new concept options could provide significant supply capacity that could reduce imported water purchases to zero percent in a normal year, a minimum delivery of 65,000 AFY was maintained due to water distribution limitations. The utilization of local supplies is significantly higher under dry-year conditions, ranging from 65 to 70 percent in the portfolios versus 56 percent in the Benchmark Portfolio.

6.5.4 Preferred Portfolio

The portfolio analysis results were used to assess the sensitivities of the concept options under differing future scenarios and/or extremes. Based on the results of the four extreme portfolios and discussions with City staff, the preferred portfolio was defined.

In addition to the In-Progress and Planned projects and programs included in the Benchmark Portfolio, the Preferred Portfolio includes the following Concept Options:

- Concept Option #5 - Dry Weather Low Flow Diversions
- Concept Options #8A - LA River Recharge into LA Forebay using Injection Wells
- Concept Option #13 - Potable Reuse with Groundwater Augmentation - Hyperion WRP to Regional System
- Concept Option #15 - Potable Reuse with Raw Water Augmentation - DCTWRP to LA Aqueduct Filtration Plant (requires #22 East-West Valley Interceptor Sewer)
- Concept Option #17 - Potable Reuse with Treated Water Augmentation - LAGWRP to Headworks Reservoir
- Concept Option #22 - East-West Valley Interceptor Sewer (EWVIS) to Increase Flows to DCTWRP for Concept Option #15

The purpose of this portfolio is to create a scenario that balances the various benefits that are desired to achieve the One Water LA Vision. By implementing these concept options, the preferred portfolio would meet not only the stormwater and receiving water quality and major water-related Sustainable City pLAN goals, but also meets the 50 percent local supply goal under dry year conditions. A map showing the approximate water routing and project locations of the concept options included in the Preferred Portfolio are depicted on Figure 6.11.

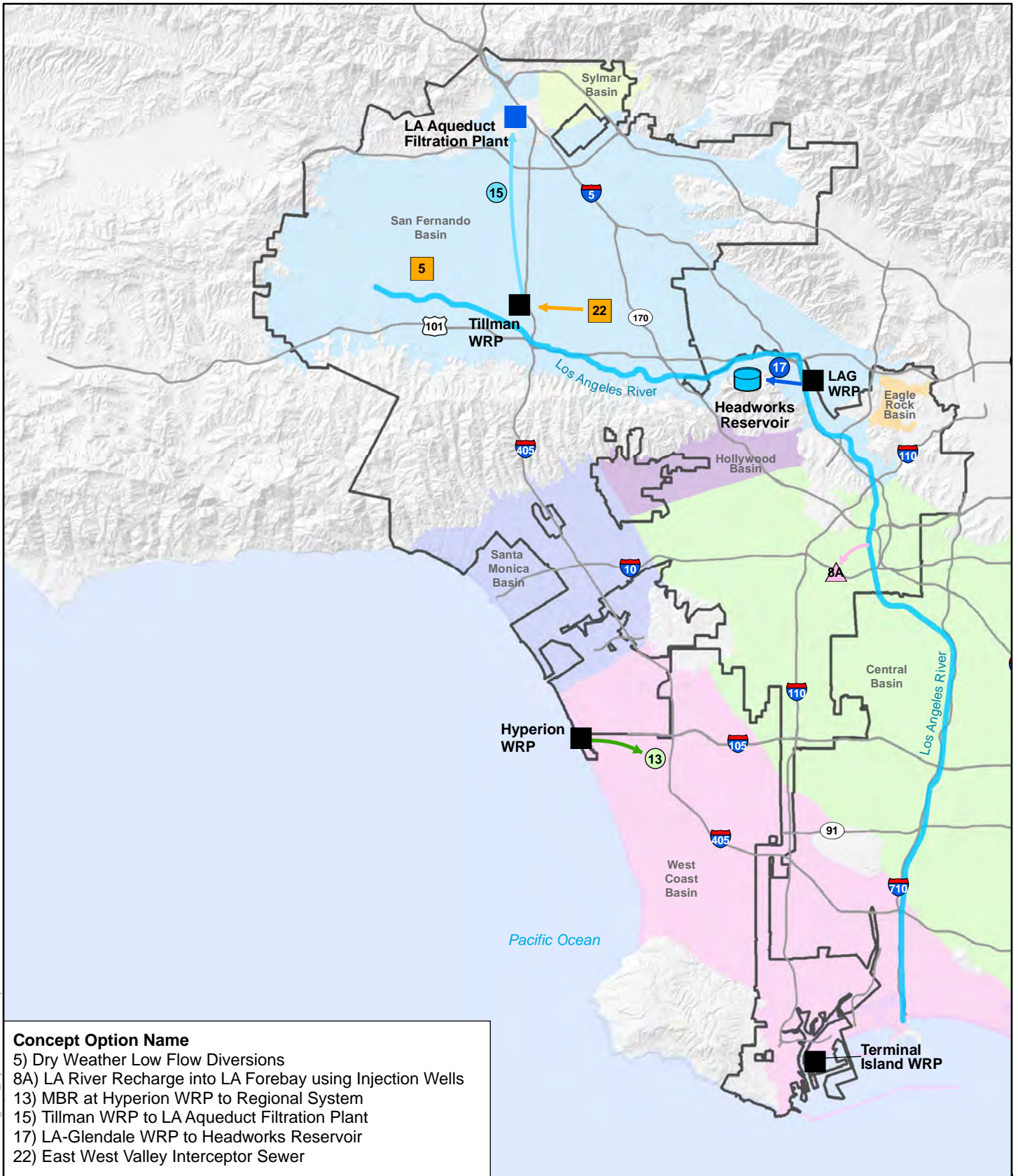

- Concept Option Name**
- 5) Dry Weather Low Flow Diversions
 - 8A) LA River Recharge into LA Forebay using Injection Wells
 - 13) MBR at Hyperion WRP to Regional System
 - 15) Tillman WRP to LA Aqueduct Filtration Plant
 - 17) LA-Glendale WRP to Headworks Reservoir
 - 22) East West Valley Interceptor Sewer

Legend

	Existing Water Reclamation Plant (WRP)		City of Los Angeles		LA River Storage and Use
	Existing Reservoir	Strategy Category			Flow Management
	Existing Water Filtration Plant		Non-Potable Reuse		
	Groundwater Basin Source: LACDPW		Potable Reuse with Groundwater Augmentation		
			Potable Reuse with Raw Water Augmentation		
			Potable Reuse with Treated Water Augmentation		

Hillshade Source: CalAtlas
<http://www.atlas.ca.gov>

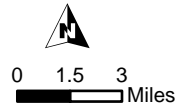

Figure 6.11 - Preferred Portfolio Map
 One Water LA 2040 Plan
 Summary Report



6.5.4.1 Estimated Yield and Cost Summary

The estimated yield and cost associated with each of the concept options that are included in the Preferred Portfolio are listed in Table 6.11.

Table 6.11 Preferred Portfolio - Estimated Yield and Cost of New Concept Options Summary Report One Water LA 2040 Plan				
#	Concept Option Name	Estimated New Yield (AFY)	Estimated Capital Cost (\$M)	Estimated Unit Cost (\$/AF)
5	Dry Weather Low Flow Diversions	6,200	\$110	\$1,000
8A	LA River Recharge into LA Forebay using Injection Wells	25,000	\$980	\$2,100
13	Potable Reuse Groundwater Augmentation - MBR at Hyperion to Regional System ⁽⁴⁾	95,000	\$900	\$1,500
15	Potable Reuse Raw Water Augmentation - DCTWRP to LA Aqueduct Filtration Plant ⁽⁴⁾	15,000	\$310	\$1,500
17	Potable Reuse Treated Water Augmentation - LAGWRP to Headworks Reservoir ⁽⁴⁾	6,000	\$140	\$1,500
22	East-West Valley Interceptor Sewer	11.4 mgd ⁽²⁾	\$85	\$430
Totals of New Concept Options Only⁽³⁾		147,200	\$2,525	\$1,600
Notes:				
(1) Requires the East-West Valley Interceptor Sewer (Concept Option #22) or other flow management option to increase flows to DCTWRP.				
(2) Estimated capacity of EWVIS is 11.4 mgd and does not provide a new supply, but only a flow increase to DCTWRP due to rerouting.				
(3) Excludes new yield and cost estimates associated with Benchmark Portfolio projects and programs.				
(4) The estimated yield of Concept Options #13 and #17 could not be fully utilized during normal and wet year conditions with the supply mix assumptions obtained from the 2015 UWMP.				

As shown in Table 6.11, the estimated combined yield of the new concept options included in the Preferred Portfolio is 147,200 AFY, which excludes the capacity of Concept Option #22 (East-West Valley Interceptor Sewer) as this is a flow management concept that does not generate new supply by itself. A potential alternative or addition to the EWVIS is the Japanese Garden and Sepulveda Basin Lakes Recirculation concept, which would require a Wastewater Change Petition (Water Code Section 1211) to allow reduced discharge to Balboa Lakes and is therefore not included at this planning stage. The corresponding capital investment of the new concept options included in the Preferred Portfolio is approximately \$2.5 billion, in addition to the estimated cost of the Benchmark Portfolio. The yield weighted average unit cost is approximately \$1,600/AF assuming that all projects can be fully utilized on a continuous basis. However, the MBT indicated that the capacity of Concept Option #15 had to be reduced during some hydrologic conditions due to insufficient flow availability. Hence, further optimization of concept sizing would be required to avoid building facilities with stranded capacity.

The results of the Preferred Portfolio evaluation are discussed in detail in TM 5.3 (see Volume 5) and are briefly summarized below:

- The Preferred Portfolio recycling rate is equal to or higher than the other portfolios. The Preferred Portfolio utilizes 32 and 58 percent of the available recycled water flow under normal- and dry-year conditions, respectively (compared to an average of 2 percent in the period 2011-2016).
- The Sustainable City pLAn goals of reducing imported water purchases by 50 percent by 2025 are exceeded under normal- and dry-year conditions with 85 and 61 percent reduction respectively.
- The Sustainable City pLAn goal to source 50 percent of the City's water supply locally by 2035 is exceeded in normal- and dry-year conditions with 56 and 73 percent locally sourced water, respectively. The local water supply percentage is similar or higher compared to the themed portfolios (compared to an average of 16 percent in the period 2011-2016).
- The Sustainable City pLAn goal to capture 150,000 acre-feet of stormwater annually by 2035 is exceeded in normal year conditions.

The projected water supply mix in 2040 under normal- and dry-year conditions with the Benchmark Portfolio and concept options of the Preferred Portfolio are shown on Figure 6.12.

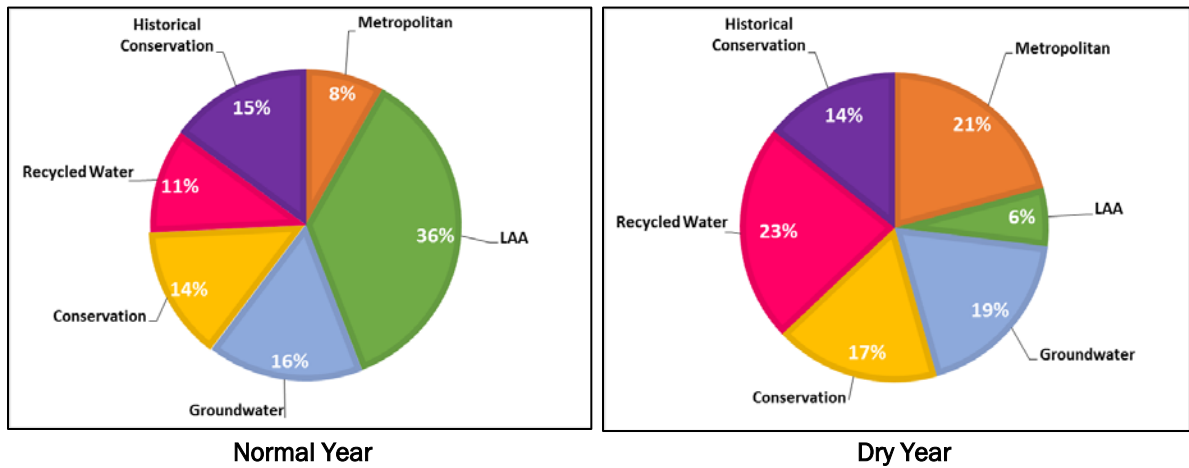

Figure 6.12 Preferred Portfolio - 2040 Supply Mix for a Normal and Dry Year

The Preferred Portfolio is estimated to cost the City an additional \$2.5 billion, on top of the \$8.2 billion Benchmark Portfolio, for a total estimated cost of \$10.7 billion. This equates to a yield-weighted unit cost of roughly \$1,600/AF. However, the estimated capital and yield-weighted unit cost of the Preferred Portfolio reflects the average cost of the other four portfolios.

6.6 PREFERRED PORTFOLIO

The following sections briefly summarize the recommended concept options included in the preferred portfolio. Schematics of all 27 concept options are included in Appendix B of the Summary Report. Individual concept description sheets are included in Appendix C of TM 5.2 (see Volume 5).

Concept Option 5: Dry Weather Low Flow Diversions

This concept option involves collecting low flows from the stormwater system and transferring them to the sewer system for treatment. Under normal year conditions, the estimated yield from city-wide implementation is 6,200 AFY, while the yield-weighted unit cost is roughly \$1,000 per AF. The concept flow schematic is shown on Figure 6.13.

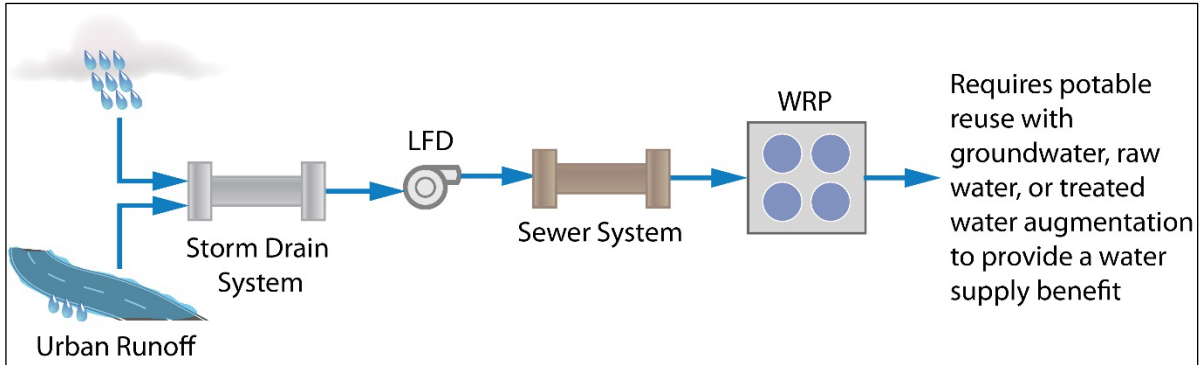

Figure 6.13 Dry Weather Low Flow Diversions

The key benefits associated with this concept option include, but are not limited to:

- Minimizes or eliminates the discharge of potentially polluted dry-weather flow runoff from receiving waters.
- Diverts dry-weather runoff in the stormwater collection system to the sewer collection to be conveyed to a wastewater reclamation plant for treatment and reuse.
- Moreover, this concept option helps fulfill the following One Water objectives and guiding principles:
 - Improve health of local watersheds.
 - Improve local water supply reliability.
 - Integrate management of water resources and policies.
 - Balance environmental, economic, and societal goals.

Concept Option 8A: LA River Recharge into LA Forebay using Injection Wells

This concept option diverts flows from the LA River to the LA Forebay to recharge Central Basin. Under normal year conditions, the estimated yield is 25,000 AFY, while the yield-weighted unit cost is roughly \$21,000 per AF. The concept flow schematic is shown on Figure 6.14. For additional details regarding the LA River refer to the LA River Flow Study, Volume 4.

The key benefits associated with this concept option include, but are not limited to:

- Extracts and reusing excess water that would otherwise be lost to the ocean.
- Replenishes the Central Basin groundwater aquifer.

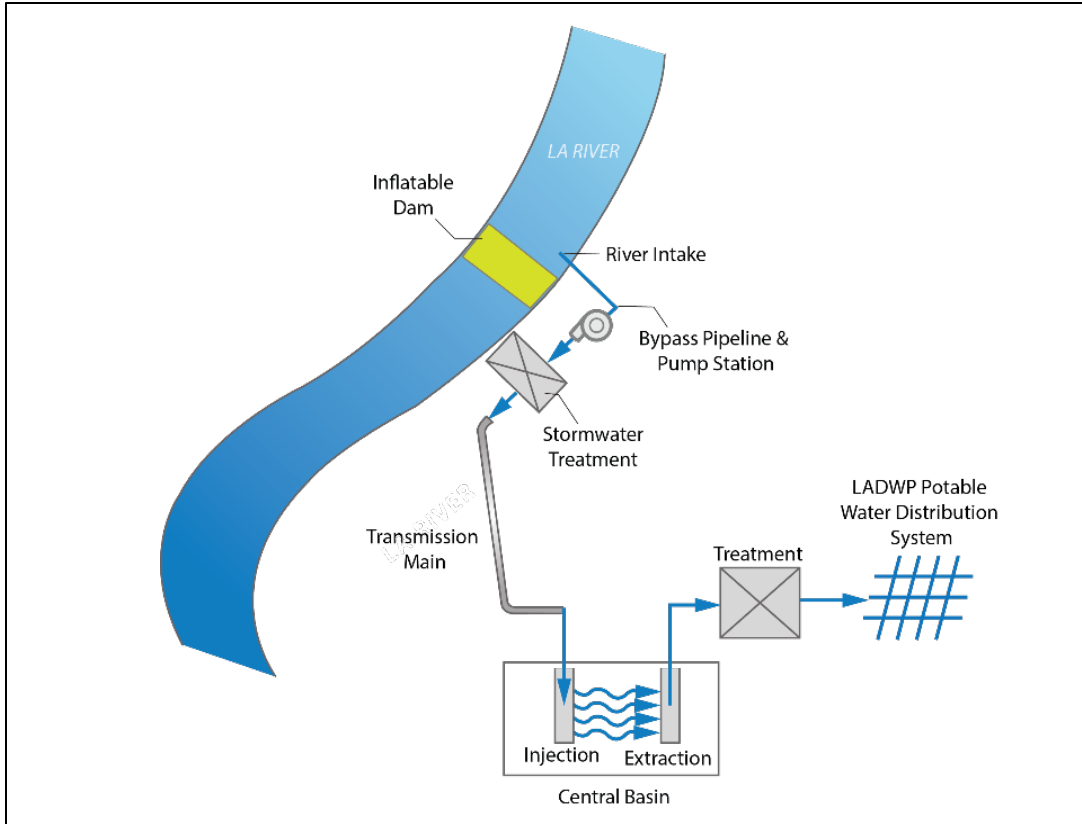

Figure 6.14 LA River Recharge into LA Forebay using Injection Wells

Moreover, this concept option helps fulfill the following One Water objectives and guiding principles:

- Improve local water supply reliability.
- Increase climate resilience.
- Increase community awareness and advocacy for sustainable water.
- It is important to note that Concept Option 8B, LA River Recharge into LA Forebay is more cost effective than Concept Option 8A. Concept Option 8B was developed late in the project and therefore was not ranked or scored and may be challenging from a regulatory standpoint. However, it is recommended that Concept Option 8B is also considered and evaluated in more detail before the City moves forward with the implementation of Concept Option 8A.

Concept Option 13: Potable Reuse - MBR at Hyperion WRP to Regional System

This concept treats HWRP effluent with a membrane bioreactor (MBR) and delivers water to a regional system for recharge into a groundwater basin, which will be extracted for potable use by other regional systems. This project may also be used in the future for potable reuse with raw water augmentation. Advanced treatment by the regional system will be required. The LADWP could purchase this water from a regional system for potable use.

Under normal year conditions, the estimated yield is 95,000 AFY, while the yield-weighted unit cost is roughly \$1,500 per AF. The concept flow schematic is shown on Figure 6.15.

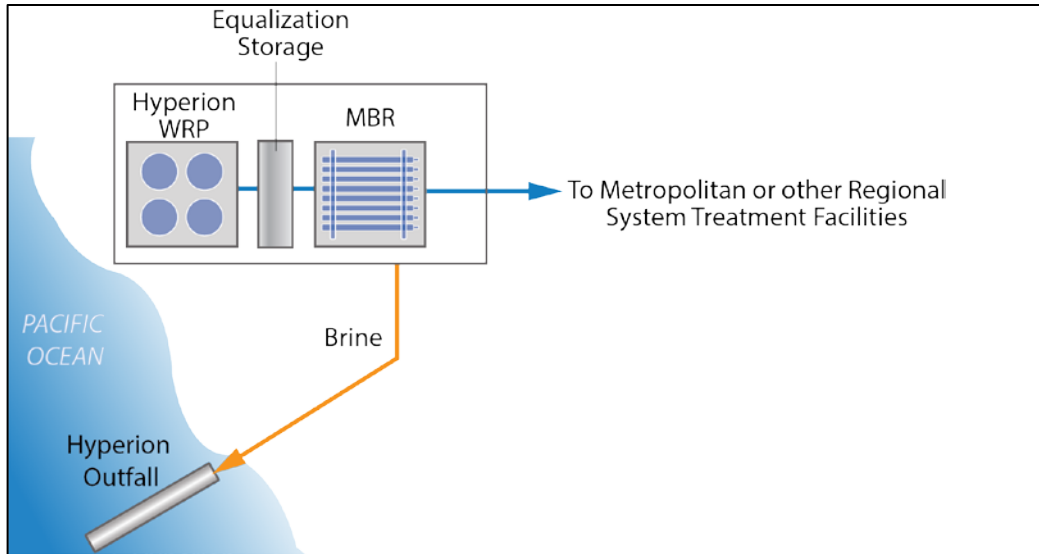

Figure 6.15 Potable Reuse - MBR at Hyperion WRP to Regional System

The key benefits associated with this concept option include, but are not limited to:

- Uses 100 percent of Hyperion Water Reclamation Plant flows for recycling eliminating discharge to the ocean.
- Promotes collaboration with regional partners.
- Delivers water to a regional system for recharge into a groundwater basin, which will be extracted for potable reuse and sold to water retailers at full service rates.
- Moreover, this concept option helps fulfill the following One Water objectives and guiding principles:
- Implement, monitor, and maintain a reliable wastewater system.
- Improve local water supply reliability.
- Integrate management of water resources & policies.
- Increase climate resilience.

Concept Option 15: Potable Reuse Raw Water Augmentation - Tillman WRP to Los Angeles Aqueduct Filtration Plant

This concept option expands the DCTWRP Advanced Water Purification Facility (AWPF) and conveys potable reuse flows with raw water augmentation to the Los Angeles Aqueduct Filtration Plant (LAAFP), and then to LADWPs system for distribution.

Under normal year conditions, the estimated yield is 15,000 AFY, while the yield-weighted unit cost is roughly \$1,500 per AF. The concept flow schematic is shown on Figure 6.16.

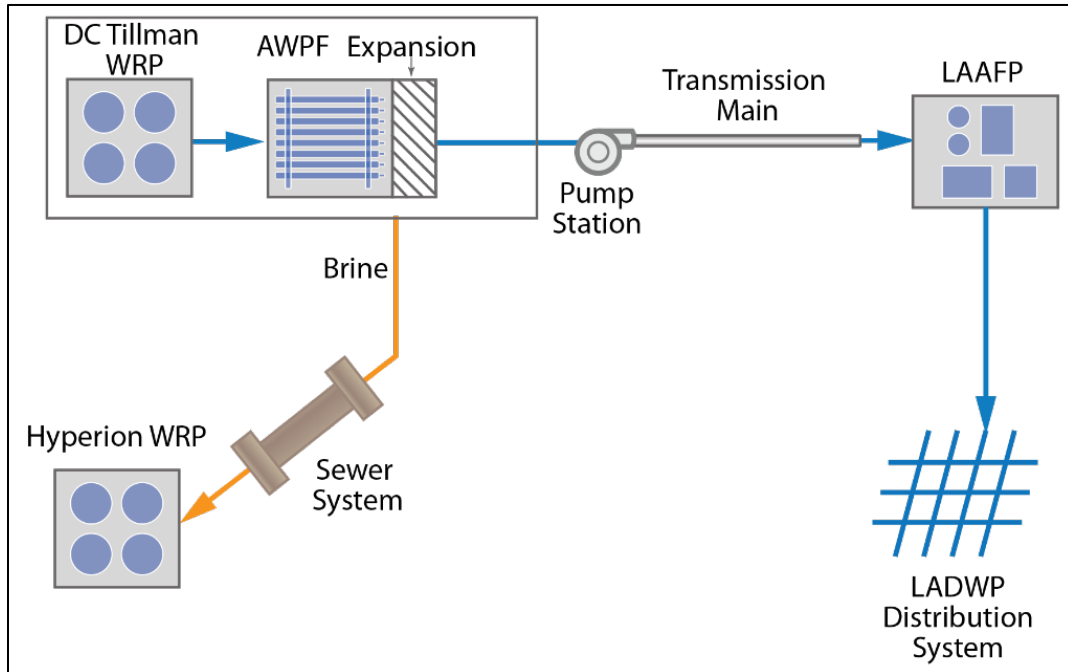

Figure 6.16 Potable Reuse Raw Water Augmentation - Tillman WRP to Los Angeles Aqueduct Filtration Plant

The key benefits associated with this concept option include, but are not limited to:

- Expands use of potable reuse with raw water augmentation.
- Increases DCTWRP's flows for recycling.
- Moreover, this concept option helps fulfill the following One Water objectives and guiding principles:
 - Implement, monitor, and maintain a reliable wastewater system.
 - Improve local water supply reliability.
 - Integrate management of water resources and policies.
 - Increase climate resilience.

Concept Option 17: Potable Reuse Treated Water Augmentation - LA-Glendale WRP to Headworks Reservoir

This concept option treats LAGWRP effluent at an Advanced Water Purification Facility (AWPF) and pumps water directly into the LADWP distribution system at the Headworks Reservoir. Instead of siting the AWPF at LAGWRP, an AWPF could be sited at the Headworks Reservoir, however, this siting location was not part of this evaluation, and further studies are required.

Under normal year conditions, the estimated yield is 3,600 AFY, while the yield-weighted unit cost is roughly \$1,500 per AF. The concept flow schematic is shown on Figure 6.17.

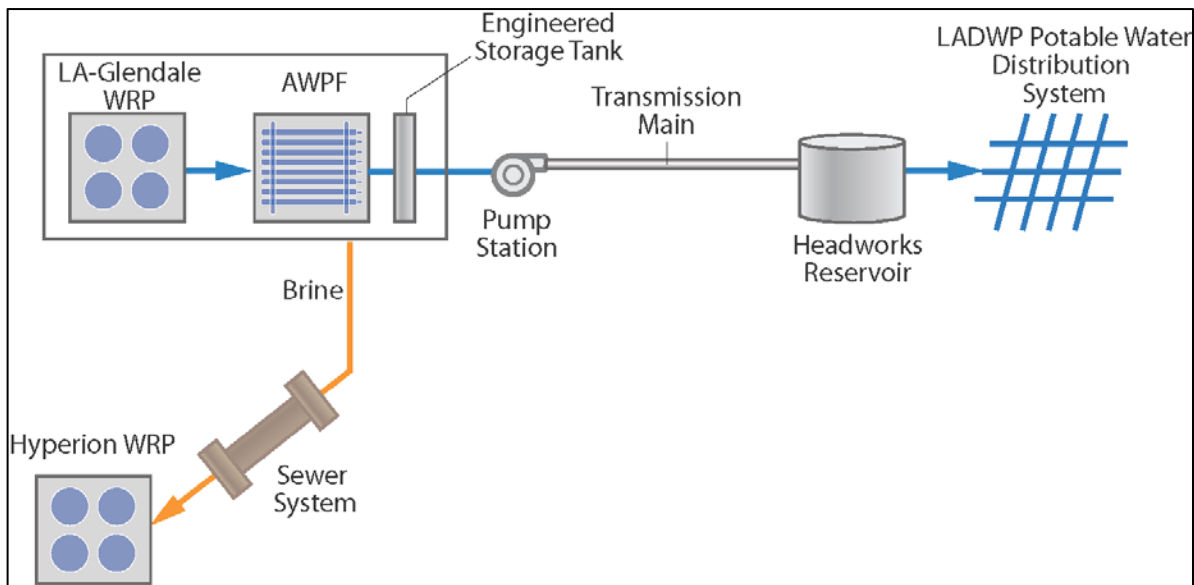

Figure 6.17 Potable Reuse Treated Water Augmentation - LA-Glendale WRP to Headworks Reservoir

The key benefits associated with this concept option include, but are not limited to:

- Expands LAGWRP's treatment technology and increases flows available for recycling.
- Expands use of potable reuse with treated water augmentation.
- Moreover, this concept option helps fulfill the following One Water objectives and guiding principles:
 - Implement, monitor, and maintain a reliable wastewater system.
 - Improve local water supply reliability.
 - Integrate management of water resources and policies.
 - Increase climate resilience.

Concept Option 22: East West Valley Interceptor Sewer

This concept option constructs the East West Valley Interceptor Sewer (EWWIS) and transfers up to 11.4 mgd to DCTWRP.

The EWWIS has an estimated capacity of 11.4 mgd and does not provide a new supply. Instead, it merely increases flow to DCTWRP due to rerouting. The yield-weighted unit cost is roughly \$430 per AF. The concept flow schematic is shown on Figure 6.18.

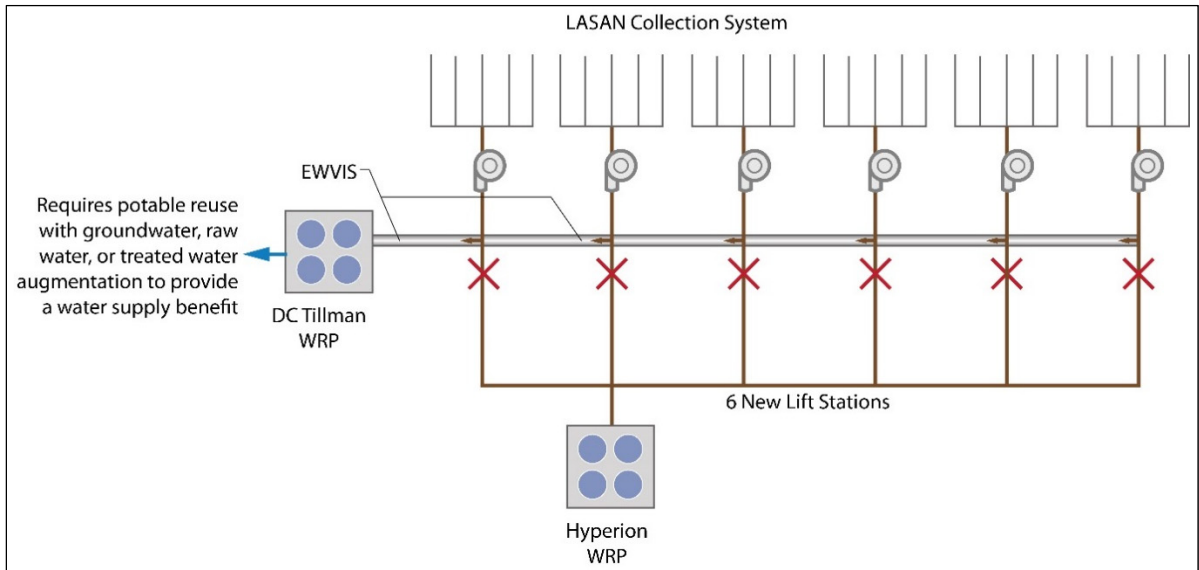

Figure 6.18 East West Valley Interceptor Sewer

The key benefit associated with this concept option includes, but is not limited to:

- Maximizes City water reclamation plants' available treatment, recycling, and potable reuse capacity (i.e. direct water where it is needed) by redirecting wastewater from one sewershed to another.
- Moreover, this concept option helps fulfill the following One Water objectives and guiding principles:
- Implement, monitor, and maintain a reliable wastewater system.
- Improve local water supply reliability.
- It is important to note that Concept Option 26 Japanese Garden and Sepulveda Lakes Recirculation could also be done in conjunction with or instead of the East West Valley Interceptor. Concept Option 26 was developed late in the project and therefore was not ranked or scored. However, it is recommended that Concept Option 26 is also considered and evaluated in more detail before the City moves forward with the implementation of Concept Option 22.

6.6.1 Summary of Preferred Portfolio

- As shown in Table ES.1 and on Figure 6.19, the corresponding estimated cost of the new concept options in the preferred portfolio is approximately \$2.5 billion. Their yield-weighted average yield-weighted unit cost is approximately \$1,600 per acre-foot (\$/AF), assuming that all projects can be fully used continuously.
- As shown on Figure 6.19, most of the costs are associated with Concept Option #8A (\$1 billion, or 39 percent) and Concept Option #13 (\$900 million, or 36 percent). The remaining five concept options represent a total estimated cost of \$1 billion, or 35 percent of the total cost. As shown, the estimated cost contribution of these six concepts ranges from 3 percent to 39 percent of the total costs.

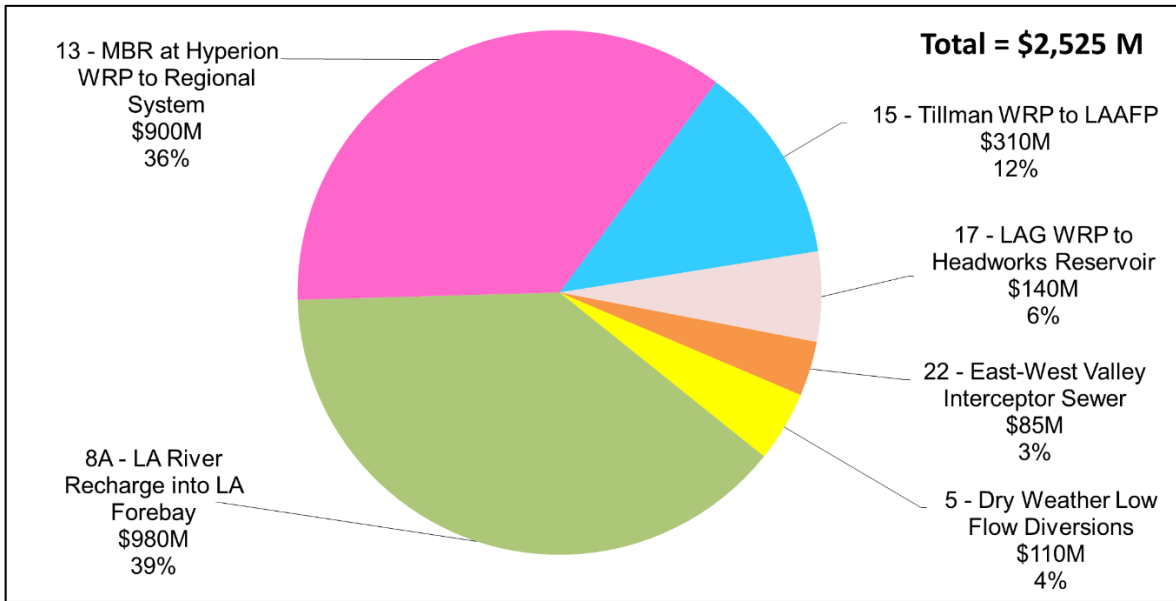

Figure 6.19 Estimated Cost Distribution of Future Integration Opportunities

Although some of the concept options did not score favorably due to high estimated cost and/or limited other benefits, it should be noted that some of the concept options that are currently not included in the Preferred Portfolio remain good viable alternatives. As shown in Table 6.7, some concept options are included in multiple portfolios, while other options are not included in any portfolios. Additionally, some of the recommended concept options depend on certain triggers occurring. In case certain triggers do not materialize, other concept options could provide an alternative to achieve the same overall goals. A dynamic trigger-based implementation strategy guides the City with the decision-making process to implement individual concept options only when needed and feasible. The trigger-based implementation strategy and policies are presented in Chapter 9.

WASTEWATER FACILITIES PLAN

Chapter 7 provides a summary of the Wastewater Facilities Plan (WWFP), which is included as Volume 2 of the One Water LA 2040 Plan (Plan). The WWFP describes the City of Los Angeles' (City) existing wastewater collection and water reclamation plants (WRPs), as well as the recommended improvements to meet future conditions. Both existing system and future system improvements are combined in a comprehensive capital improvement plan (CIP), which is documented in detail in the WWFP and summarized at the end of this Chapter.

This Chapter first describes the purpose of the WWFP and the basis of planning. Subsequently, the existing WRPs and collection system are discussed, followed by a summary of the future system analysis and the recommended wastewater facilities CIP.

7.1 WASTEWATER FACILITY PLAN PURPOSE

The City of Los Angeles Bureau of Sanitation (LASAN), is responsible for implementing, operating, maintaining, and monitoring a reliable, and sustainable system that conveys and treats wastewater in a cost efficient and environmentally prudent manner while complying with all regulatory permits. LASAN is also playing an important role in meeting the Mayor's water supply goal of sourcing 50 percent of the City's water supply locally by 2035 by appropriately evaluating their WRPs for future opportunities. To add to its role in protecting public health and the environment, LASAN has significant responsibilities for the city-wide stormwater system and solid waste services. LASAN serves over 4 million residential and industrial customers in the City. Additionally, LASAN also provides conveyance and treatment services for an estimated 600,000 residences outside of the City from its 29 contract agencies.

The purpose of the WWFP is to guide LASAN with its decision making related to the implementation of system improvements to its wastewater collection and treatment facilities. The WWFP provides the underlying documentation to make informed decisions when considering investments to repair, replace, or enhance existing facilities and construct new water conveyance or treatment facilities through year 2040. This WWFP is an update of the Wastewater Facilities Plan that was included in the 2006 Water Integrated Resources Plan (Water IRP). This WWFP incorporates expansions, upgrades, and enhancements made since 2006 and builds upon Los Angeles Department of Water and Power's (LADWP) 2015 Urban Water Management Plan (UWMP). It is anticipated that the WWFP will be updated in approximately ten years to incorporate system modifications as well as changes in flow conditions, regulatory framework, and overall vision for wastewater system operations and water reuse.

The WWFP provides recommendations for each plant on how to best utilize the water reuse opportunities and provide environmental stewardship. Among the water reuse opportunities explored are non-potable reuse (NPR) and potable reuse, groundwater augmentation, raw water augmentation, and treated water augmentation. The WWFP used a trigger-based CIP process for the future integration opportunities, which is similar to the approach that was used for the Water IRP. This trigger-based CIP is explained in more detail in Chapter 10 and is designed to help the City

navigate the wide range of future circumstances by considering changes in wastewater flows, as well as regulatory, institutional, and other conditions.

7.2 BASIS OF PLANNING

The WWFP is developed using discrete planning parameters. The basis of planning parameters consist of the planning horizon, study area, regulatory requirements, and wastewater flows, which are briefly described below, and discussed in depth in Volume 2.

- **Planning Horizon:** The planning horizon of the WWFP is year 2040. The intermediate planning period is divided into three phases: near-term (2018-2020); mid-term (2021-2030); and long-term (2031-2040).
- **Study Area:** The study area of the WWFP closely coincides with the City boundary and encompasses approximately 533 square miles. However, certain elements of the WWFP, such as flow, economics, and recycling opportunities transcend City boundaries when considering contract agencies and cities, as well as other involved neighboring entities. A more detailed discussion can be found in Section 7.2.1.
- **Wastewater Flows:** Wastewater flow projections are an important foundation for facility planning. Due to substantial water conservation in the past decades, wastewater flows have substantially decreased. Based on the anticipated effect of demand hardening and moderate growth, the City's combined wastewater flows are projected to increase from 328 million gallons per day (mgd) in the current year (2016) to 376 mgd by 2040. Details on the flow projections by plant are summarized in Section 7.2.2.
- **Regulatory Requirements:** The WWFP considers both existing and anticipated changes to regulations that pertain to wastewater treatment, effluent discharge, and water reuse. A more detailed description of the applicable regulatory framework is summarized in Section 7.2.3.

The WWFP was developed with the One Water LA Objectives and Guiding Principles, developed as part of Phase 1, which pertain specifically to the City's wastewater system and recycling opportunities. These objectives are listed below:

- **Objective 5 -** Implement, monitor, and maintain a reliable wastewater system that safely conveys, treats, and reuses wastewater while also reducing sewer overflows and odors.
- **Objective 6 -** Increase climate resilience by planning for climate change mitigation and adaptation strategies in all City actions.

Subsequently, Guiding Principles were developed to provide direction on achieving the objectives. These Guiding Principles are not intended to define specific steps for project implementation but to steer the planning process. The Guiding Principles that were used in the development of this WWFP are listed below:

- Optimize the use of existing City assets and infrastructure and explore opportunities for distributed solutions in order to safely convey, treat, and reuse wastewater.
- Optimize water reuse from the City's wastewater system, with particular emphasis on the Hyperion Water Reclamation Plant (HWRP).
- Raise the priority of water issues in relevant City plans that impact sustainability, climate adaptation/resiliency, and emergency preparedness.

The WWFP has reviewed and incorporated these Guiding Principles in the planning process to collectively help achieve the One Water LA Vision as described in Chapter 1 of this Plan. More specifically, the WWFP proposes options to maximize reuse flows at HWRP and studies climate risk mitigation and adaptation strategies for each of the water reclamation plants as well as the collection system.

7.2.1 Wastewater System Service Area





The WWFP study area coincides with the City's wastewater system service area, which can be divided into two distinct wastewater drainage areas, as well as seven major sewersheds. The drainage areas, major sewersheds, and the City's four WRPs are shown on Figure 7.1 and Figure 7.2.

Figure 7.1 shows the two primary drainage areas, the Hyperion Service Area (HSA) and the Terminal Island Service Area (TISA). These drainage areas are divided into seven major sewersheds, as shown on Figure 7.2.

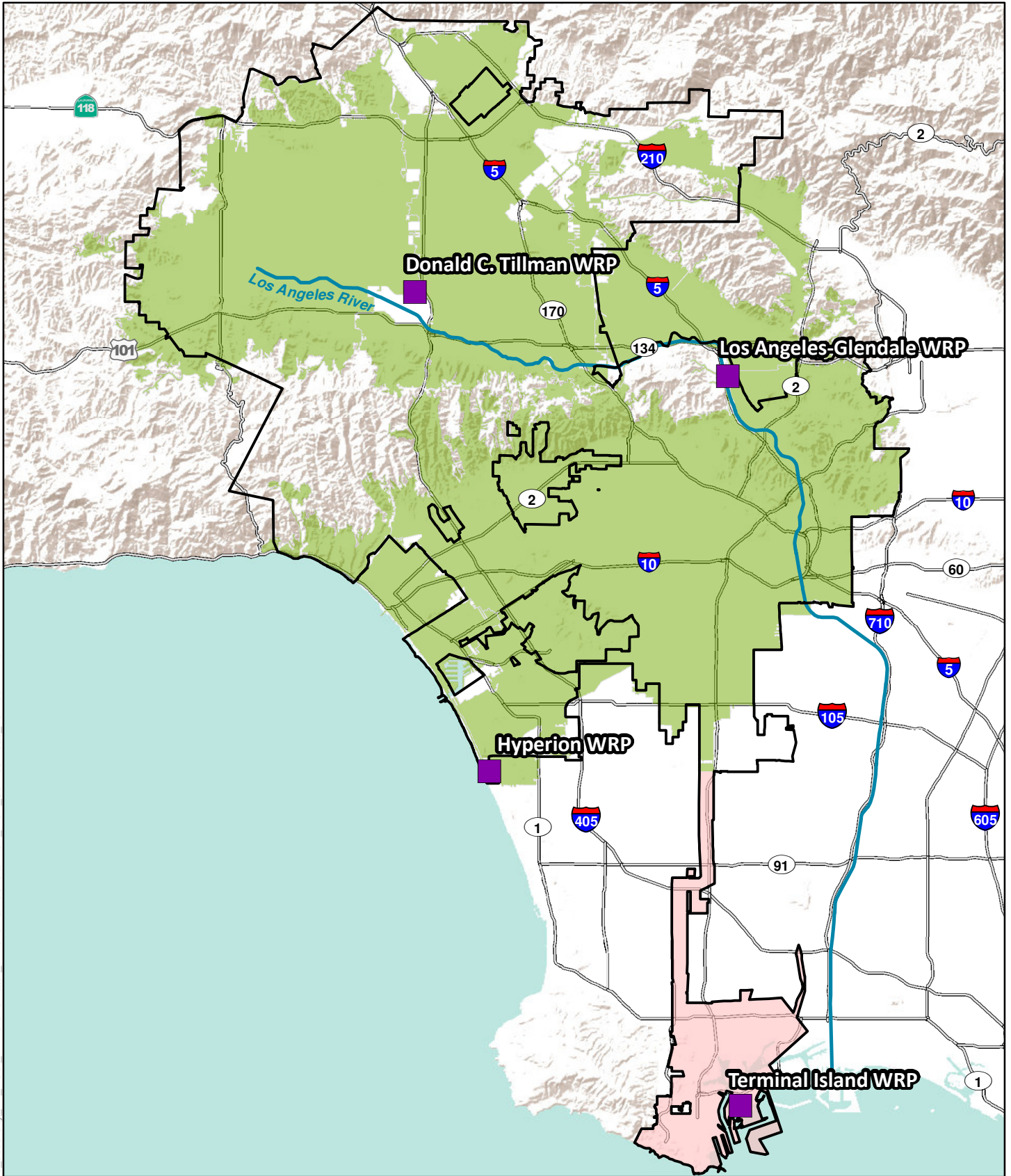
The HSA covers approximately 515 square miles, servicing the majority of the Los Angeles region. The HSA has six sewersheds which are the Donald C. Tillman sewershed, Valley Springs (VS) sewershed, Foreman Line sewershed, Coastal Interception Sewer (CIS) sewershed, Los-Angeles Glendale sewershed, and Hyperion-Metro sewershed. In addition to collecting flows from these sewersheds, the HSA collects, conveys, and treats wastewater from the City's 29 contract agencies that are located outside the City boundary. The entire HSA ultimately drains to the HWRP, while portions of the flows are treated at the inland satellite plants, namely Donald C. Tillman Water Reclamation Plant (DCTWRP) and Los Angeles-Glendale Water Reclamation Plant (LAGWRP).

The TISA is approximately 18 square miles and serves the Los Angeles Harbor area. The TISA consists solely of the Terminal Island sewershed. Most of the TISA drains to the Terminal Island Water Reclamation Plant (TIWRP), while a small portion of the flows are pumped to the Los Angeles County Sanitation Districts (LACSD), Joint Water Pollution Control Plant (JWPCP).



-  Existing Water Reclamation Plant (WRP)
-  City of LA Boundary
-  Hyperion Service Area (HSA)
-  Terminal Island Service Area (TISA)

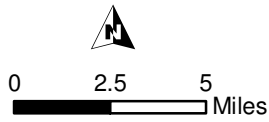
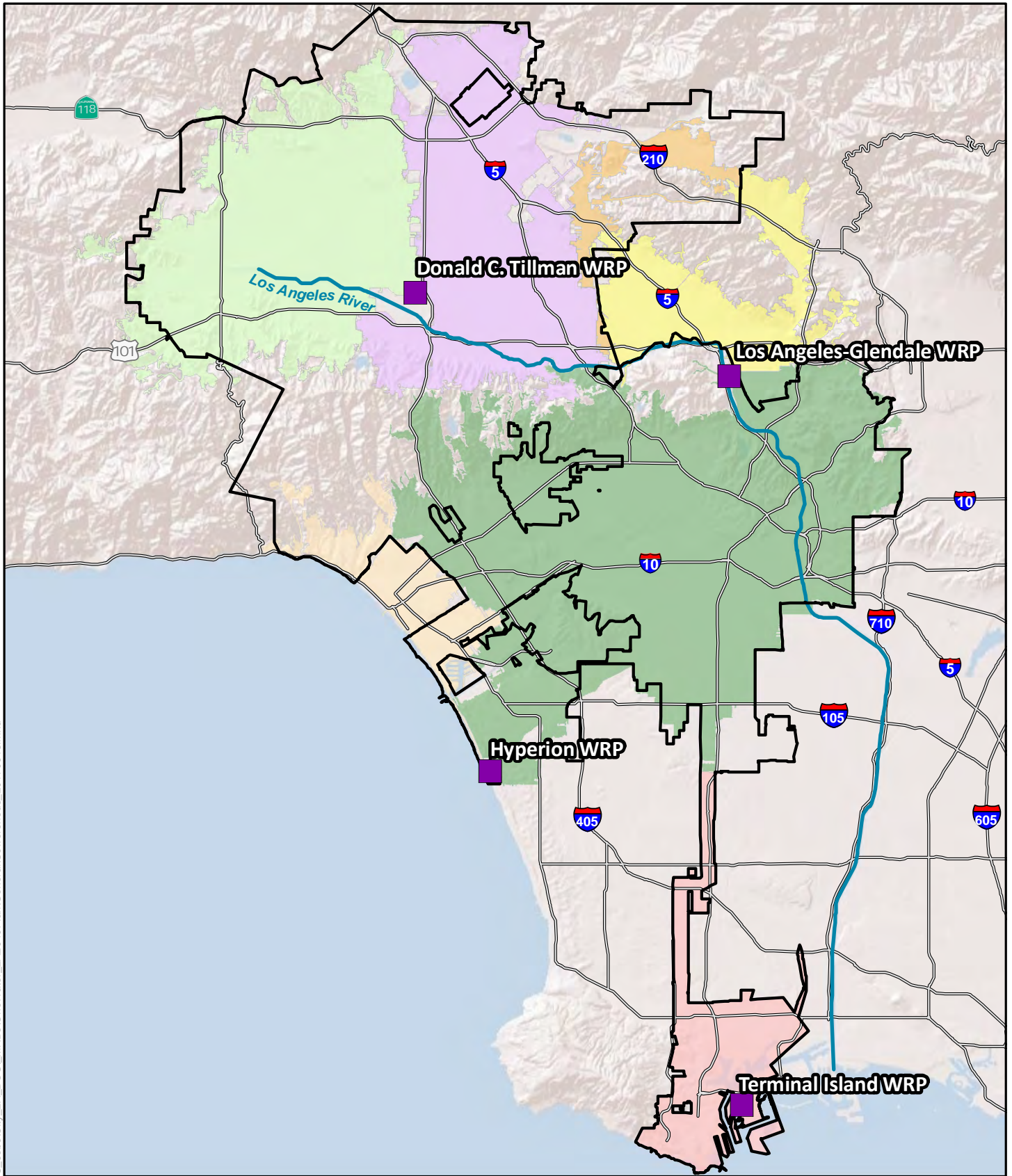

Figure 7.1 - HSA and TISA Service Boundaries
One Water LA 2040 Plan
Summary Report











- | | |
|--|--|
|  Existing Water Reclamation Plant (WRP) |  HWRP Metro Sewershed |
|  City of LA Boundary |  DCTWRP Sewershed |
|  Terminal Island Sewershed |  CIS Sewershed |
|  LAGWRP Sewershed |  Valley Springs Sewershed |
|  Foreman Line Sewershed | |

Figure 7.2 - Los Angeles Sewersheds
One Water LA 2040 Plan
Summary Report



7.2.2 Wastewater Flow Projections

Knowledge of future flow projections is vital to CIP planning and management of the wastewater system assets for collection and treatment. Figure 7.3 compares the 2006 Water IRP projections (2005-2020), the actual annual average wastewater flows (2002-2016), and the One Water LA 2040 Plan flow projections. As shown on Figure 7.3, the 2006 Water IRP projected approximately 451 mgd of wastewater influent within the HSA and TISA boundaries in 2015. The actual annual average wastewater influent flows in 2015 for these service boundaries were significantly lower, totaling approximately 337 mgd. This yields a difference of 114 mgd between the projected and the actual flows. This significant difference of influent flows can largely be attributed to the City's successful water conservation efforts. The Plan wastewater influent projections account for conservation efforts and develop flow projections based on estimated conservation, increased population and expected system growth. As a result, the 2020 flow projections differ by 131 mgd between the Water IRP and the Plan projections.

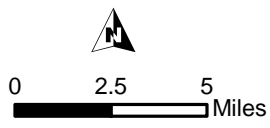
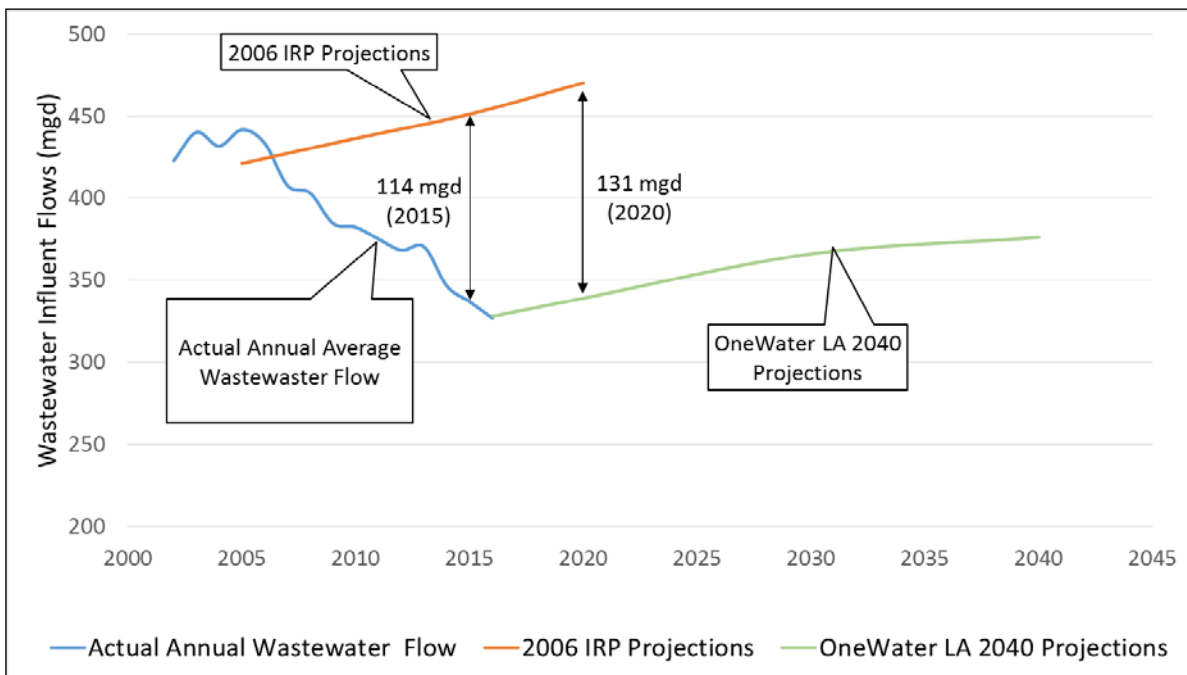

Figure 7.3 Projected and Historical Average Annual Wastewater Flows

Future wastewater flows are expected to increase due to growth in population as well as commercial, and industrial activity. The 2015 UWMP, in conjunction with SCAG census data, projects a growth of an additional 493,200 people within the City by 2040. The population is expected to continue to grow over the next 25 years at a rate of 0.5 percent annually. This represents a reduction to the historical 1 percent annual growth rate that occurred between 1980 and 2010. Population growth is expected to lead to an increase in commercial and industrial activity, likely resulting in an increase in wastewater flows in the City's service area. In general, the UWMP states that dry weather wastewater influent flow projections for the WRPs are expected to increase by 20 percent over the next 25 years.

Along with population growth, wastewater flows will also be influenced by economic activity, weather, and water conservation. However, once conservation efforts are maximized, the demand values are "hardened" and greater efforts are required to create substantive reductions.

It should be noted that this forecast includes the anticipated flows due to the recommended implementation of additional dry weather low flow diversions (LFDs). LFDs are designed to route dry weather stormwater flows into the sewer collection system via a pumping facility at locations and times when the sewer system has excess conveyance capacity. The purpose of these LFDs is twofold; 1) capturing and rerouting stormwater to help meet stormwater quality compliance goals, and 2) route additional flows to WRPs to increase the potential for water reuse. The City has already implemented numerous dry weather LFDs throughout the City increasing the potential for water reuse. These dry weather stormwater flows to the City plans to implement a policy to reduce the overall dry weather runoff while also expanding the number of LFDs to maximize dry weather capture. It is anticipated that the City can capture an additional 6,200 acre feet per year (AFY) or 6.5 mgd of flow with LFDs. Depending on which LFDs are built, this could increase influent flows particularly at the inland plants, DCTWRP and LAGWRP. The proposed LFD locations are shown on Figure 7.4.

As shown in Table 7.1, the combined flow of all four WRPs is projected to increase from roughly 328 mgd in 2016 to 376 mgd in 2040. Table 7.1 shows the breakdown of current and future flow projections for each plant. Figure 7.5 show that the total system net flow will increase by 13 percent by 2040.

Table 7.1 Projected Wastewater Flows Summary Report One Water LA 2040 Plan				
Water Reclamation Plant (WRP)	Projected Annual Average Wastewater Flows by Year^(1,2,3)			
	2016	2020	2030	2040
Hyperion	250 mgd	256 mgd	275 mgd	283 mgd
Donald C. Tillman	47 mgd	46 mgd	51 mgd	53 mgd
Los Angeles-Glendale	17 mgd	21 mgd	22 mgd	22 mgd
Terminal Island	14 mgd	16 mgd	18 mgd	18 mgd
Total	328 mgd	339 mgd	366 mgd	376 mgd
Notes:				
(1) Flows are rounded to the nearest mgd.				
(2) The LFDs are assumed to be implemented starting in Year 2030.				
(3) mgd = million gallons per day				

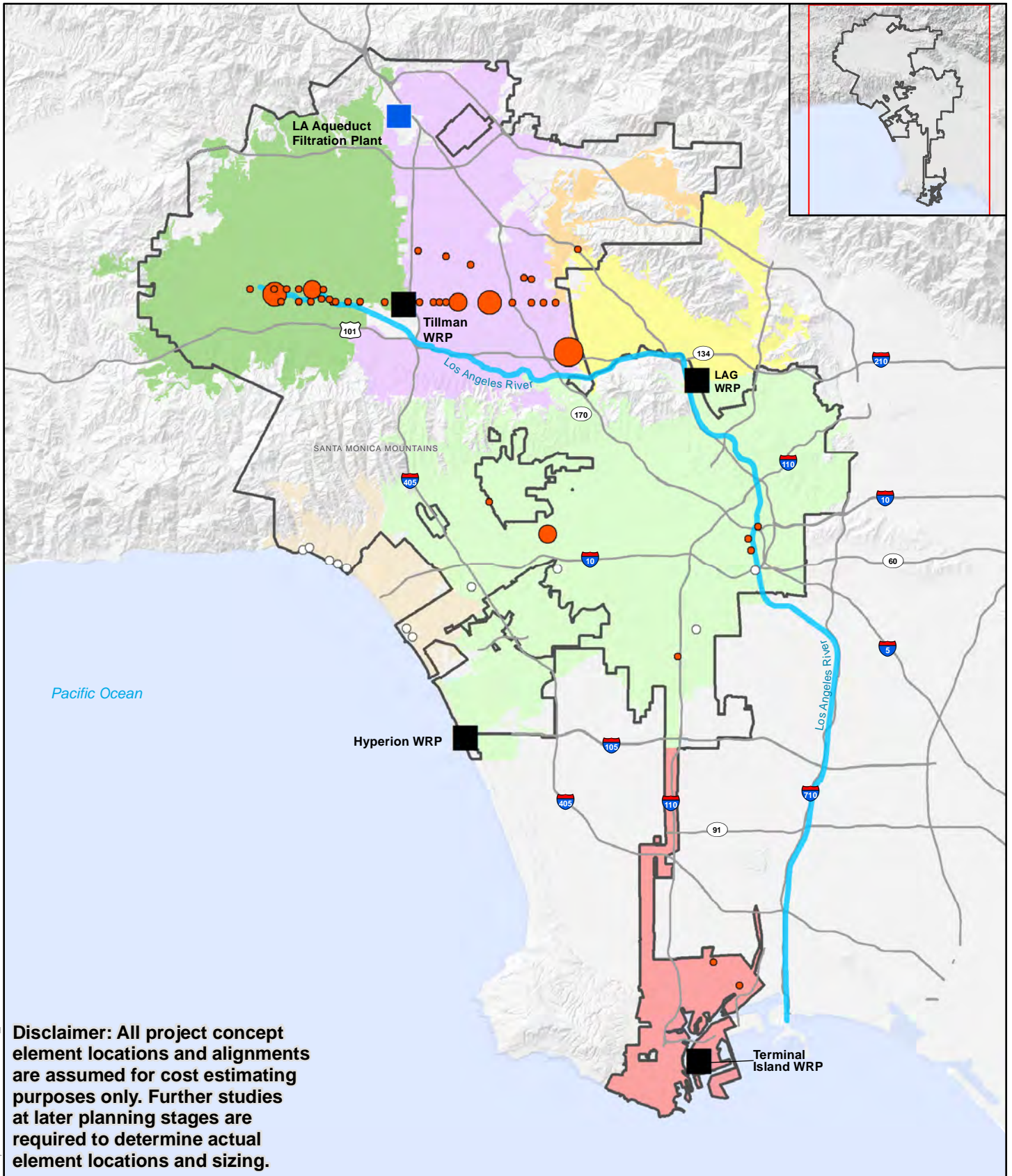

Disclaimer: All project concept element locations and alignments are assumed for cost estimating purposes only. Further studies at later planning stages are required to determine actual element locations and sizing.

Legend

- Existing Water Reclamation Plant (WRP)
- Existing Water Filtration Plant
- City of Los Angeles

Proposed Low Flow Diversion Locations Inflow (MGD)

- < 0.2
- 0.3 -0.4
- 0.5-0.6
- 0.7-0.8
- >1.0



Hillshade Source: CalAtlas
<http://www.atlas.ca.gov>

Figure 7.4 - Low Flow Diversions
 One Water LA 2040 Plan
 Summary Report

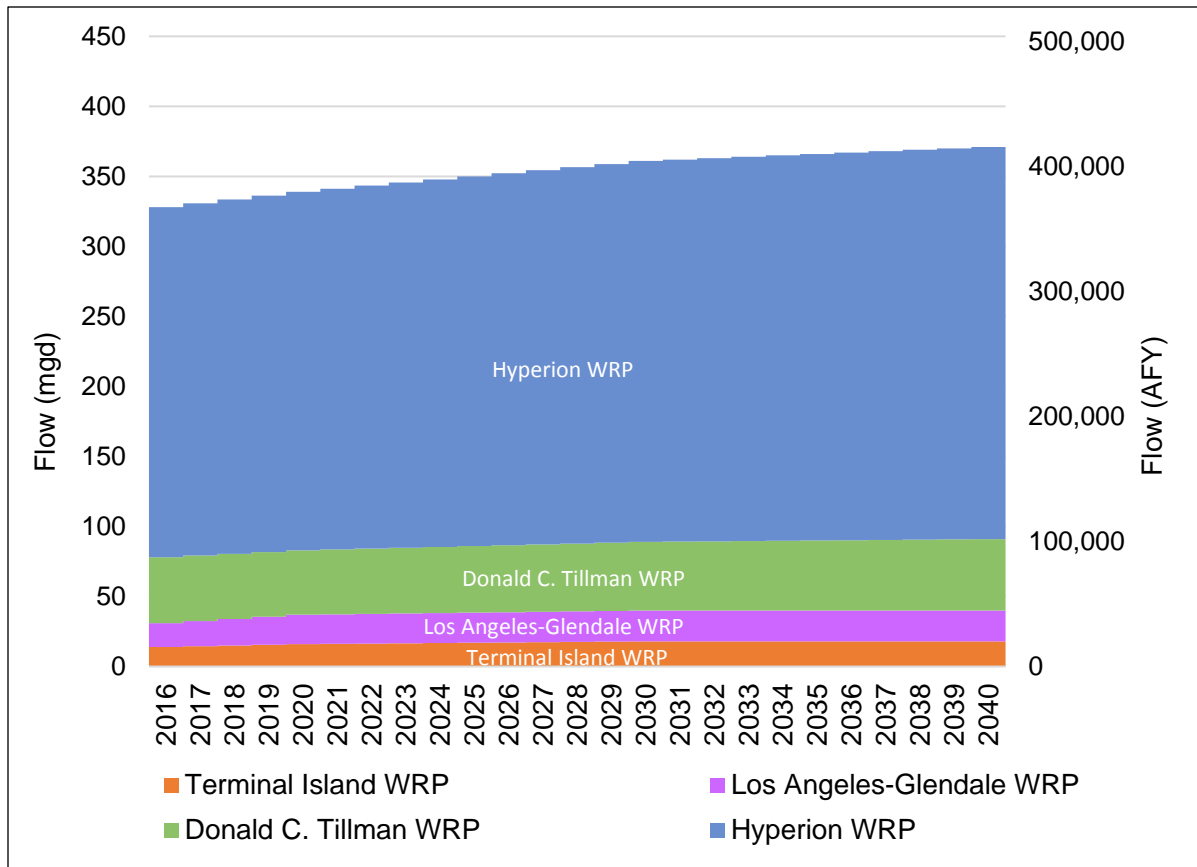

Figure 7.5 Wastewater Flow Projections by WRP

The increased flows that are anticipated to be treated at the inland plants (DCTWRP and LAGWRP) would result in a reduction in the flow that would otherwise be treated at HWRP. The flows to TIWRP are anticipated to increase the least, due to the build out of the sewer collection area, however there are discussions to bring additional sewer flow into the area.

7.2.3 Non-Potable Reuse

Currently, recycled water is most commonly used for non-potable (not for drinking) purposes, such as agriculture, landscape irrigation, and industrial uses. Other specific non-potable applications include dust control, construction activities, concrete mixing, parks, golf courses, and artificial lakes. The use of non-potable water reduces the amount of potable water used for the aforementioned purposes and thereby reduces the City's reliance on imported water. Non-potable reuse must be compliant with regulations set forth in California Code of Regulations Title 22 (Title 22), which specifies the allowed uses of recycled water at various treatment levels. The current effluent quality at DCTWRP, LAGWRP, and TIWRP meets these standards. Effluent from TIWRP is of advanced water treatment (AWT) quality.

7.2.4 Potable Reuse

Potable reuse can be distinguished as three types:

- Potable reuse with groundwater augmentation - Projects that would spread (infiltrate) or directly inject recycled water into a groundwater basin that could be used as potable water after extraction and further treatment.
- Potable reuse with raw water augmentation prior to delivery - Projects that would deliver advanced treated recycled water (purified water) to a conventional water treatment plant before distributing into a potable water system.
- Potable reuse with treated water augmentation prior to delivery into the potable water distribution system - Projects that would deliver advanced treated recycled water (purified water) directly to a potable water system.

7.2.5 Regulatory Drivers

Regulations affecting water reclamation plants are established by a variety of agencies, such as the US Environmental Protection Agency (EPA), Los Angeles Regional Quality Water Control Board (RWQCB-LA), Division of Drinking Water (DDW), and the South Coast Air Quality Management District (SCAQMD).

U.S. EPA delegates the regulatory oversight to the DDW and the RWQCB-LA. The RWQCB-LA issues permits for the WRPs. A National Pollution Discharge Elimination System (NPDES) permit, which governs the discharge from the existing WRPs is issued by the RWQCB-LA. An NPDES permit can contain discharge requirements for total maximum daily loads (TMDLs), sanitary sewer overflow (SSO) controls, and various regulations for receiving waters and recycled water specific to the water body.

LASAN has water reuse programs at each of its four water reclamation plants. As previously stated, these regulations are governed by the DDW and the RWQCB-LA in the California Code of Regulations Title 22, Division 4, and Chapter 3 (Title 22). These regulations establish required treatment levels and water quality levels dependent upon the end use of recycled water.

In addition to the regulations that have been established, the changing regulatory environment has the ability to impact the WRPs. Table 7.2 summarizes potential regulatory drivers that may impact each of the water reclamation plants. This list is not intended to be exhaustive of every possibility, but instead provides an overview of which plants could potentially be impacted as a result of potential future regulations. Details of these potential drivers are summarized in the WWFP (See Volume 2).

Table 7.2 below shows that all four water reclamation plants could be impacted if regulations governing the discharge of brine are passed. Also, all four water reclamation plants would require upgrades should the potable reuse regulations be approved and potable reuse is subsequently implemented by LASAN. The listed potential SCAQMD regulations would only apply to HWRP and TIWRP where solids are processed and methane gas could be produced.

Table 7.2 Future Regulatory Drivers for WRP Planning Summary Report One Water LA 2040 Plan					
Potential Drivers	Potential Process(es) Requirement	HWRP	DCTWRP	LAGWRP	TIWRP
Potable Reuse					
Treated Water Augmentation	Install advanced treatment process such as Ozone, BAC, MF, RO, UV-AOP	X	X	X	X
Increased Nitrogen standards for discharge to inland waters	Enhancement of nitrogen removal processes, increase in peak flow detention time through equalization, optimization of the activated sludge systems or installation of MBR or a combination of the above and research of alternative treatment technologies for the more stringent nitrogen standard		X	X	
Nitrogen standards for Ocean discharge	Requires the implementation of an improved biological system, to produce an effluent with low nitrogen levels and adaptability for potable reuse. Includes evaluation of the current HPO system to achieve compliance with the new standards and potential conversion to a biological process utilizing air and covered aeration tanks with spent air treatment	X			X
Increased SCAQMD Emission Standards for methane and NOX	Installation of gas cleanup and low emission flares to meet lower NOX standards	X			X
Brine disposal regulations	Installation of Zero Liquid Discharge, deep well injection	X	X	X	X
Abbreviations: BAC = biologically activated carbon, MF = microfilter, RO = reverse osmosis, UV-AOP = ultraviolet advanced oxidation process, MBR = membrane bioreactor, HPO = high purity oxygen, NOX = nitrogen oxide					

7.3 WASTEWATER COLLECTION SYSTEM

The existing wastewater collection system and the planned near-term and long-term wastewater collection system improvements are described in the following subsections. Details of these improvements can be found in the Wastewater Collection System (see Volume 2).

7.3.1 Existing Collection System

Wastewater is conveyed throughout the sewersheds by an extensive collection system comprised of a network of underground sewer pipes, trunk mains, and pump stations, leading to one or more of the WRPs. The wastewater collection system's physical structure includes major interceptors and mainline sewers, inspection and maintenance access points, pumping plants, various diversion structures, odor control facilities and other support facilities, including mobile and fixed maintenance units.

The City has a number of large, major trunklines that connect the various sewersheds. The entire sewer collection system consists of more than 6,700 miles of pipeline, 43 pumping plants, and 19 major outfall diversion structures. Due to topography, the majority of the sewer flows are conveyed by gravity to the four WRPs.

Some of the sewer flows tributary to DCTWRP and LAGWRP can be diverted to HWRP. In addition, residual waste streams from DCTWRP and LAGWRP are discharged back into the collection system for treatment at HWRP. The daily flows that are treated at these two inland plants are dictated by operational conditions and recycled water demands, which vary seasonally. Effluent from DCTWRP and LAGWRP that is not reused is discharged to the Los Angeles River. Effluent from HWRP that is not sent to West Basin Municipal Water District (WBMWD) is discharged to the ocean through a 5 mile outfall. The majority of the effluent from TIWRP is recycled, but a portion may be discharged to the Harbor under certain discharge permit conditions.

7.3.2 Near-Term Planned Collection System Improvements

LASAN does routine maintenance and rehabilitation of the wastewater collection system and maintains a running list of capital improvement projects that are prioritized and budgeted. In addition to regular replacements and upgrades, LASAN has four major improvements planned in the near-term, as summarized in Table 7.3.

Table 7.3 Near-Term Wastewater Collection System Improvements Summary Report One Water LA 2040 Plan	
Project	Description
LAGWRP Primary Effluent Equalization Storage	This project will construct one 2.5-million gallon primary effluent storage tanks for flow equalization, two 24-inch pipelines, two primary tanks, three aeration tanks, two secondary clarifiers at the LAGWRP. This storage tank will relieve the North Outfall Sewer (NOS) by attenuating peak flows in the system through storage.
NOS Rehabilitation	The City plans to expedite 18 NOS rehabilitation projects. The City will also assess and rehabilitate 16 miles upstream of Valley Spring Lane and Foreman Avenue using CCTV and laser and sonar profiling.
Venice Pumping Plant Dual Force Main	This project will construct a second force main sewer to operate in conjunction with the existing force main in order to meet existing peak wet weather flow demands, provide isolation for cleaning and maintenance, and allow for operational flexibility and reliability.
Venice Auxiliary Pumping Plant	This project will provide a new pumping plant adjacent to the existing Venice Pumping Plant, a new electrical building, and a new generator. Additionally, this project will provide site security and control capabilities for both the existing and new auxiliary plant.

The projects summarized in Table 7.3 are anticipated to be implemented within the near-term planning horizon and have been incorporated into the CIP.

7.3.3 Long-Term Collection System Improvements

In anticipation of future flows, LASAN has currently identified one major conveyance project for the future, namely the San Fernando Relief Sewer. This project would consist of approximately 4 miles of 48-inch diameter sewer to provide redundancy to the North Outfall Sewer (NOS). The relief sewer would also provide capacity to facilitate a shutdown of the LAGWRP during a storm event, if necessary.

Other collection system improvement projects have been identified by LASAN to appropriately plan and budget for the 2040 planning horizon. These projects are included in the CIP discussed in Section 7.8.

7.4 WATER RECLAMATION PLANTS

As described previously, the City owns and operates the following four water reclamation plants:

1. **HWRP** – This plant is located in Playa del Rey along the Pacific Ocean, just south of the Los Angeles International Airport (LAX);
2. **DCTWRP** – This plant is located in the San Fernando Valley, in the Sepulveda Basin;
3. **LAGWRP** – This plant is located east of Interstate 5 (I-5), east of Griffith Park, and is co-owned with the City of Glendale;
4. **TIWRP** – This plant is located on an island in the Los Angeles Harbor, approximately 20 miles south of downtown Los Angeles.

The treatment process, design capacity, and average flow (2016) of each plants' treated effluent are summarized in Table 7.4. Existing and future facilities at each plant are described in greater detail in subsequent sections of this Chapter.

Table 7.4 Water Reclamation Plant Summary Summary Report One Water LA 2040 Plan			
Water Reclamation Plant	Treatment Process Train	Average Dry Weather Flow Capacity (mgd)	Average Dry Weather Flow (mgd)⁽³⁾
HWRP	Secondary treatment ⁽¹⁾	450	250
DCTWRP	Tertiary treatment ⁽²⁾ following activated sludge (AS) nitrification denitrification	80	47
LAGWRP	Tertiary treatment following AS nitrification denitrification	20	17
TIWRP	Tertiary treatment following AS nitrification and	30	14
	Advanced water purification treatment	12	2.4
Notes:			
(1) Secondary Treatment is defined as removal of biodegradable organic matter and suspended solids.			
(2) Tertiary Treatment is defined as the removal of residual solids (following secondary treatment) through the use of granular medium filtration or microscreens. Disinfection is also part of tertiary treatment			
(3) mgd = million gallons per day, 2016 annual average flow			

The following subsections summarize the characteristics of each of the four WRPs, while additional information is included in the WWFP (see Volume 2).

7.4.1 HWRP

HWRP is the City's oldest and largest water reclamation plant in Los Angeles. The plant is bounded by Imperial Highway on the north, Vista Del Mar on the west, Scattergood Generating Station (SGS) on the south, and the City of El Segundo on the east. Located within the Hyperion Service Area, HWRP treats wastewater from a tributary area of approximately 515 square miles. HWRP also receives and treats process residual flows from DCTWRP, LAGWRP, the Burbank Water Reclamation Plant (BWRP), and the Los Angeles Zoo Treatment Facility (LAZTF).

HWRP is rated and permitted to treat an average flow of 450 mgd and a peak wet weather flow of 850 mgd. However, with the success of water conservation and substantially decreased sewer flows, average flows in 2016 were 250 mgd. Currently, HWRP is operated as a full secondary treatment facility utilizing high purity oxygen activated sludge process. After treatment, a majority of the effluent is discharged to Santa Monica Bay through a 5 mile long outfall, terminating at a depth of 200 feet. The remaining effluent is pumped to WBMWD for additional treatment dependent upon reuse demand. As shown on Figure 7.6, the treatment process at HWRP consists of preliminary, primary, and secondary treatment. A more detailed process flow diagram for HWRP is provided in Chapter 4 of the WWFP (see Volume 2).

HWRP has a contractual partnership with WBMWD to send a portion of the HWRP effluent to WBMWD's Edward C. Little Water Recycling Facility (ECLWRF), which provides additional treatment to produce various qualities of recycled water to customers in the south bay, the west side, and parts of the Los Angeles Harbor. In addition, a portion of the effluent is treated at the Service Water Facility at HWRP for use within the plant.

HWRP has state of the art solids processing units using thermophilic anaerobic digestion for organics stabilization, pathogen reduction, and the production of biogas and treated solids for reuse. LASAN has recently completed the Hyperion Bio-Energy Facility (HBEF) to use HWRP's digester biogas for renewable energy generation. The treated solids can be beneficially reused through composting or used for agricultural soil enhancement at the City's Green Acres Farm.

Currently, there are a number of ongoing and planned In-Progress Projects at HWRP. The following are the ongoing projects most relevant for the purpose of this Plan:

- **Secondary Treatment Process Upgrade:** Evaluations are underway at the HWRP to assess the feasibility of upgrading a portion of secondary treatment to deliver higher quality effluent and increased quantities (up to 70 mgd) to WBMWD. As part of this evaluation, HWRP staff is considering the implementation of a Pilot Test Facility to determine the scalability of a membrane bioreactor (MBR) system and to optimize downstream processes.
- **Los Angeles Wastewater Integrated Network System (LAWINS):** The City is in the process of updating the distributed control system that will allow the four WRPS and pumping plants to be effectively and efficiently controlled as one system.

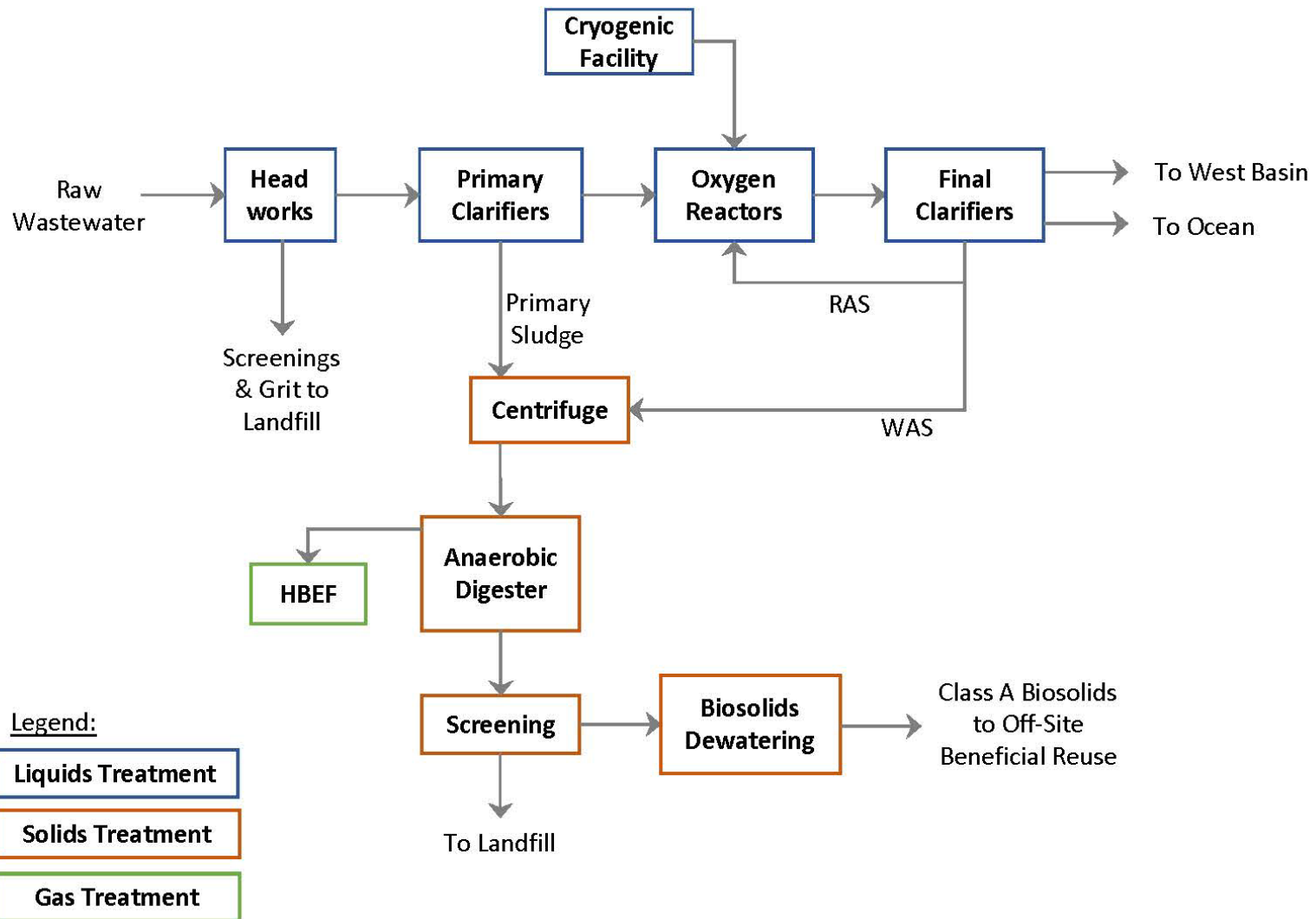

Figure 7.6 - Process Flow Diagram for HWRP
 One Water LA 2040 Plan
 Summary Report

In-Progress Projects are planned projects that are expected to be implemented outside and independent of the One Water LA 2040 Plan. More information on In-Progress Projects is found in Chapter 6 of this Summary Report. The In-Progress Projects for HWRP are:

- **Advanced Treated Recycled Water Delivery to LAX and Scattergood Generating Station (In-Progress Project #5):** The City is in the process of implementing a 1.5 mgd advanced water treatment facility serving Los Angeles International Airport, SGS, and HWRP internal users. In the future, the facility could be expanded with an additional 3.5 mgd of treatment capacity, for a total capacity of 5 mgd.
- **HWRP Delivery Expansion to 70 mgd for West Basin Municipal Water District and LA Harbor Area (In-Progress Project #6):** WBMWD and HWRP are in the process of expanding this pump station for delivery of up to 70 mgd of secondary effluent to WBMWD.

The potential future plant modifications to maximize water reuse opportunities are discussed in Section 7.5.1.

7.4.2 DCTWRP

DCTWRP is a full tertiary treatment facility located in the San Fernando Valley. The plant is located on a 91-acre site within the Sepulveda Control Basin in Van Nuys, south of Victory Boulevard, between Woodley Avenue and the San Diego Freeway (Interstate 405). DCTWRP was built in two phases, each with a capacity of 40 mgd. Hence, the plant is rated and permitted to treat an average flow of 80 mgd, and a peak wet weather flow of 160 mgd. However, water conservation has resulted in substantially decreased sewer flows, 47 mgd in 2016, so that only one phase of the plant is currently operated.

As shown on Figure 7.7, DCTWRP provides primary, secondary, and tertiary treatment with disinfection. Side streams, including residuals and any by-passed flow from the treatment processes are returned to the sewer system for treatment at HWRP. The plant effluent is compliant with Title 22 standards for non-potable reuse, and the majority of the effluent flows through Balboa Lake, Wildlife Lake, DCTWRP's Japanese Garden, and to the Los Angeles River. A more detailed process flow diagram and discussion of existing treatment processes for DCTWRP can be found in Chapter 5 of the WWFP (see Volume 2).

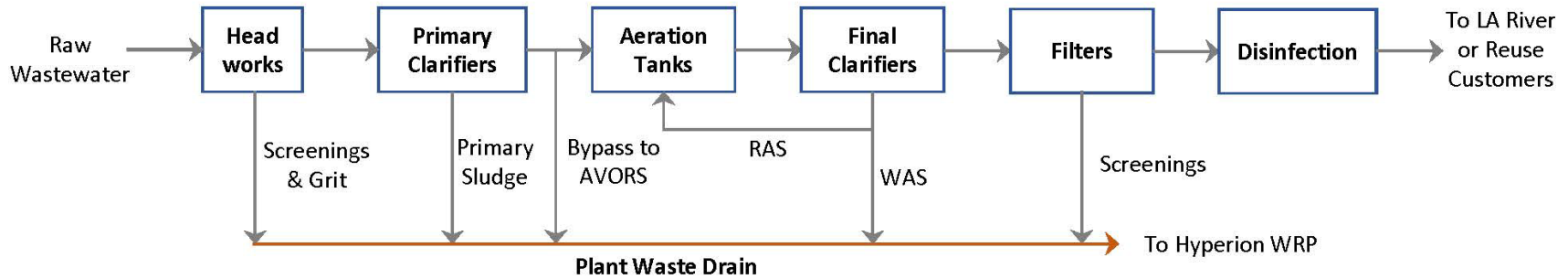

Legend:

Liquids Treatment

Solids Treatment

Figure 7.7 - Process Flow Diagram for DCTWRP
 One Water LA 2040 Plan
 Summary Report

Currently, there are a number of ongoing and In-Progress Projects at DCTWRP including the following ongoing projects:

- **Ozone Demonstration Project:** The City is implementing a demonstration project consisting of a 7-10 mgd interim ozonation system to provide ozonated tertiary treated recycled water for spreading at the Hansen Spreading Grounds. This demonstration project will provide data regarding soil aquifer treatment and aid in the development of a larger recharge program.
- **LAWINS:** The City is in the process of updating the distributed control system that will allow the four water reclamation plants and pumping plants to be effectively and efficiently controlled as one system.

The In-Progress Project for DCTWRP consists of:

- Groundwater Replenishment Project with Advanced Water Purification Facility (AWPF) at DCTWRP (up to 30,000 AFY in San Fernando Basin) (In-Progress Project #2): DCTWRP is adding an AWPF to the plant yielding purified water for groundwater recharge at the Hansen and Pacoima Spreading Grounds. The purpose of this Groundwater Replenishment (GWR) project is to recharge the San Fernando Basin and ultimately increase the amount of local water supply to meet the City's water supply reliability goals.

The potential future plant modifications to maximize water reuse opportunities are discussed in Section 7.5.2.

7.4.3 LAGWRP

LAGWRP is located in the City of Glendale, across the Golden State Freeway from Griffith Park, and serves eastern San Fernando Valley communities. The plant is co-owned by the cities of Los Angeles and Glendale and operated by LASAN. LAGWRP provides preliminary, primary, secondary, and tertiary treatment, followed by disinfection. LASAN and the City of Glendale equally share in the cost of the plant operation and thus have an equal share in the recycled water that is produced.

LAGWRP is rated and permitted to treat an average flow of 20 mgd, and a peak wet weather flow of 30 mgd. However, water conservation has resulted in substantially decreased sewer flows with average flows in 2016 of 17 mgd. The plant effluent is compliant with Title 22 standards for disinfected tertiary recycled water and is pumped to either the non-potable recycled water distribution system or flows by gravity to the Los Angeles River. All solids removed from the treatment process are returned untreated to the NOS for conveyance to HWRP for downstream treatment.

A schematic of the treatment process at LAGWRP is shown on Figure 7.8. A more detailed process flow diagram for LAGWRP can be found in Chapter 6 of the WWFP (see Volume 2).

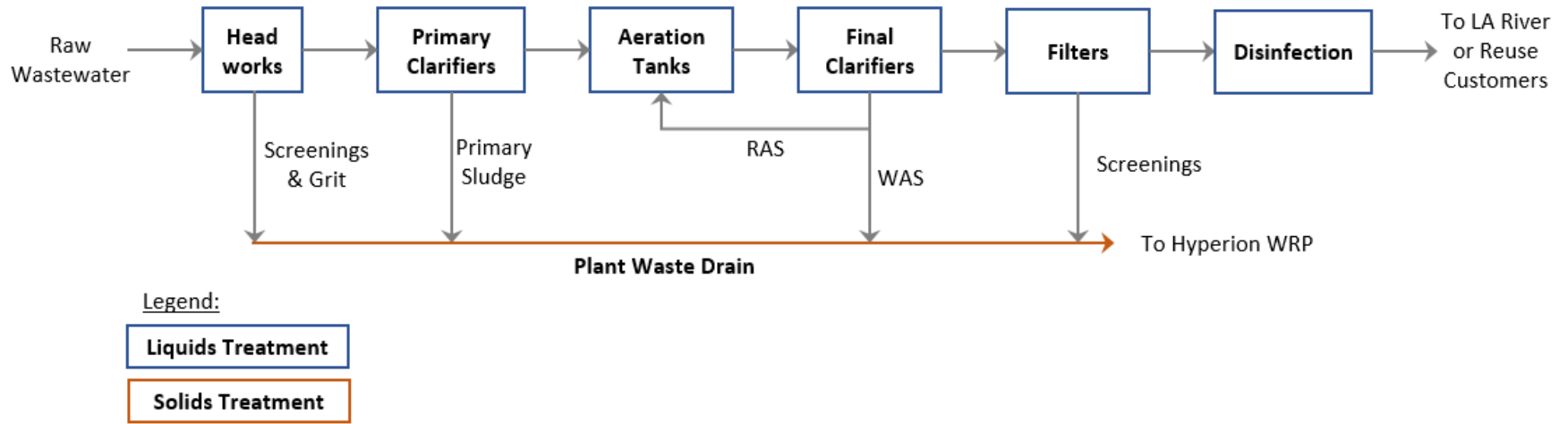

Figure 7.8 - Process Flow Diagram for LAGWRP
 One Water LA 2040 Plan
 Summary Report

Currently, there are a number of ongoing and planned In-Progress Projects at LAGWRP. The following projects are ongoing:

- **Primary Effluent Equalization Storage:** As discussed in Section 7.3.2, the plant is in the process of implementing one 2.5-million gallon primary effluent storage tanks for flow equalization, two 24-inch pipelines, two primary tanks, three aeration tanks, two secondary clarifiers. This storage tank will relieve the NOS by attenuating peak flows in the system through storage.
- **LAWINS:** The City is in the process of updating the distributed control system that will allow the four water reclamation plants and pumping plants to be effectively and efficiently controlled as one system.

The In-Progress Project for LAGWRP is:

- **Expansion of NPR per 2015 UWMP (In-Progress Project #4):** LAGWRP currently meets all recycled water demands in the -Metro Area and would continue to do so for the additional customer demand identified by this project.

The potential future plant modifications to maximize water reuse opportunities are discussed in Section 7.5.3.

7.4.4 TIWRP

TIWRP is located on Terminal Island, in Los Angeles Harbor approximately 20 miles south of downtown Los Angeles. The plant is within a 21.5-acre site at the northwest corner of Terminal Way and Ferry Street. TIWRP treats wastewater from throughout the TISA, consisting of flows from municipal, commercial, and industrial facilities. Similar to HWRP, TIWRP processes all of its residual solids from treatment processes on site.

TIWRP has the permitted capacity to provide tertiary treatment for an average dry weather flow of 30 mgd and peak wet weather flow of 55 mgd. The 2016 average flow is 14 mgd. The AWPf recently completed an expansion (In-Progress Project #3) to increase its capacity from 6 mgd to 12 mgd. This expansion included the addition of a 2 MG tertiary equalization tank, additional microfiltration units, reverse osmosis, and an advanced oxidation process. This expansion was completed during the development of the WWFP. Effluent is primarily reused for recycled water customers and injection into the Dominguez Gap Barrier.

As shown on Figure 7.9, the treatment processes at TIWRP consist of preliminary, primary, secondary, tertiary, and advanced treatment. Additional discussion of treatment processes at TIWRP's can be found in Chapter 7 of the WWFP (see Volume 2), along with a more detailed process flow diagram.

There are a number of ongoing and planned In-Progress projects at TIWRP. The LAWINS program is an ongoing project being implemented at TIWRP. The In-Progress Project for TIWRP is:

- **Expansion of NPR per 2015 UWMP (In-Progress Project #4):** The UWMP estimated 12,820 AFY of additional recycled water demand in the Harbor Area, some of which would be supplied by TIWRP. Implementation of this project would not require changes to the plant once the expansion of the AWPf is complete.

The potential future plant modifications to maximize water reuse opportunities are discussed in Section 7.5.4.

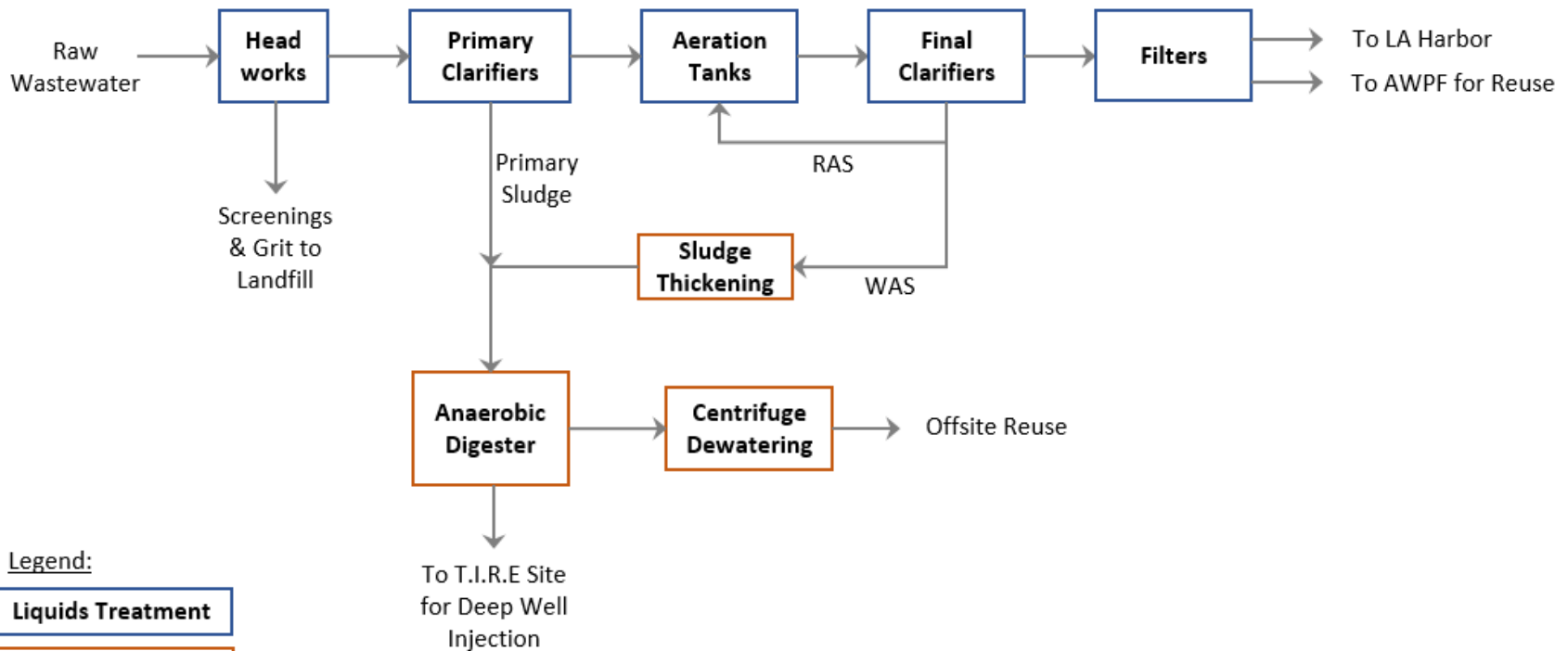

Figure 7.9 - Process Flow Diagram for TIWRP
 One Water LA 2040 Plan
 Summary Report

7.5 FUTURE WASTEWATER SYSTEM ANALYSIS

Through a series of workshops, stakeholder meetings, and engagement with the One Water LA team, a total of 27 new concept options were identified that could increase local supply availability and achieve water quality goals through collaborative projects involving multiple city departments and/or regional agencies. Each of the 27 concept options was developed, evaluated, scored, and ranked as described in Chapter 6. The 17 concept options that involved water reuse at the WRPs are summarized in Table 7.5.

Table 7.5 Water Reuse Concept Options Summary Report One Water LA 2040 Plan		
Strategy	#(1)	Name
LA River Storage and Use	7	Upper Los Angeles River to DCTWRP
	9	DCTWRP to San Fernando Basin Injection Wells
Potable Reuse with Groundwater Augmentation	10	HWRP to West Coast Basin Injection Wells
	11	HWRP to Central Basin Injection Wells
	12	HWRP to Central Basin with Spreading Basins
	13	MBR at HWRP to Regional System
	14	HWRP to San Fernando Basin Injection Wells
Potable Reuse with Raw Water Augmentation	15	DCTWRP to Los Angeles Aqueduct Filtration Plant
	20	HWRP to Los Angeles Aqueduct Filtration Plant
Potable Reuse with Treated Water Augmentation	16	DCTWRP to LADWP Distribution System
	17	LAGWRP to Headworks Reservoir
	18	HWRP to LADWP Distribution System
Non-Potable Reuse	19	HWRP to Headworks Reservoir
	23	Increase Recycled Water Demand beyond 2015 UWMP
Flow Management	24	Rancho Park Water Reclamation Facility
	22 ⁽²⁾	East-West Valley Interceptor Sewer
	26 ⁽²⁾	Japanese Garden & Sepulveda Basin Lakes Recirculation
Notes:		
(1) The numbering is intentionally out of order due to the grouping by Strategy.		
(2) These flow management concepts are not a stand-alone strategy, but provide additional flow for other potable reuse concepts.		

As part of the WWFP development, each of the 17 concept options listed in Table 7.5 was reviewed to identify improvements that would need to be implemented at the corresponding water reclamation plants as well as system changes to convey that product water. This analysis included preliminary sizing of treatment process modifications, location of the processes, and preliminary cost

estimates. Based on the overall concept score, cost estimates, and portfolio evaluation results, the concept options were prioritized for each plant. As the flows from each plant can only be utilized once, it is important to identify what the most beneficial method of water reuse is for each plant. However, implementing many concept options is dependent on certain triggers, such as regulatory conditions or institutional arrangements and more detailed feasibility studies.

As a result, the highest scoring concept option may not be viable depending on which triggers may or may not occur in the future. A more detailed discussion of the concept option scoring and portfolio evaluation results is included in Chapter 6 of this Summary Report.

To guide the City with prioritization and the decision-making process related to these future water reuse options, a trigger-based implementation strategy was developed for each WRP and is shown on subsequent figures.

As shown on each of these figures, multiple water reuse options are included for each WRP. The most preferred concept option is indicated as "Priority A," while the next best concept option is identified as "Priority B," and third best as "Priority C." It should be noted that the priorities can change in the future as the underlying conditions, assumptions, and triggers may change in the future. Hence, it is critical that the City reconsider the benefits of all concept options when deciding to move forward with the implementation of any of these concept options. A summary of triggers is provided in Chapter 10.

The preferred concept options that were identified using the triggers were incorporated into the WWFP Adaptive Capital Improvement Plan. The CIP is described in Section 7.8 of this Chapter. Further details on the development of concept options and the evaluation process can be found in Chapter 6.

The following subsections first present the concept options for each WRP, then a trigger-based implementation strategy for each WRP, and lastly describe the concept options by priority.

7.5.1 HWRP

Eight concept options at HWRP involving potable reuse with groundwater augmentation, treated water augmentation and raw water augmentation were identified and evaluated. Table 7.6 presents the priority of water reuse from HWRP based on the concept option evaluation and scoring results and Figure 7.10 presents a trigger-based implementation strategy for HWRP future concept options.

Table 7.6 HWRP Concept Options Summary Report One Water LA 2040 Plan					
Concept Option #	Title	Strategy	Estimated Yield (Normal Year)	Capital Cost (\$M) ⁽¹⁾	Unit Cost (\$/AF)
10	HWRP to West Coast Basin Injection Wells	Potable Reuse with Groundwater Augmentation	20,000 AFY (18 mgd)	\$900	\$3,200
11	HWRP to Central Basin Injection Wells	Potable Reuse with Groundwater Augmentation	75,000 AFY (70 mgd)	\$3,300	\$2,700
13	MBR at HWRP to Regional System	Potable Reuse with Groundwater Augmentation	95,000 AFY (85 mgd)	\$900	\$1,500
14	HWRP to San Fernando Basin Injection Wells	Potable Reuse with Groundwater Augmentation	20,000 AFY (18 mgd)	\$680	\$2,400
18	HWRP to LADWP Distribution System	Potable Reuse with Treated Water Augmentation	95,000 AFY (85 mgd)	\$2,800	\$2,100
19	Hyperion WRP to Headworks Reservoir	Potable Reuse with Treated Water Augmentation	95,000 AFY (85 mgd)	\$3,200	\$2,400
20	HWRP to Los Angeles Aqueduct Filtration Plant	Potable Reuse with Raw Water Augmentation	95,000 AFY (85 mgd)	\$3,600	\$2,600
Notes: (1) Total Concept Option cost includes a variety of project components including treatment facilities, conveyance, and injection and extraction facilities. Not all costs pertain to the Wastewater Facilities Plan. (2) Bold indicates a Priority A Concept Option (3) Concept Option #12 was determined to have a fatal flaw resulting from 1) a lack of capacity in the existing Rio Hondo Spreading Grounds and 2) a lack of vacant land to construct new spreading basins.					

As shown on Figure 7.10, the most critical trigger j Concept Option #13 (MBR at HWRP to Regional System) is establishing an institutional agreement with a regional project partner, such as Metropolitan Water District (MWD), the Water Replenishment District (WRD), LACSD, and/or WBMWD. If such an agreement does not materialize, the Priority B and C options could also be considered.

Hyperion Water Reclamation Plant

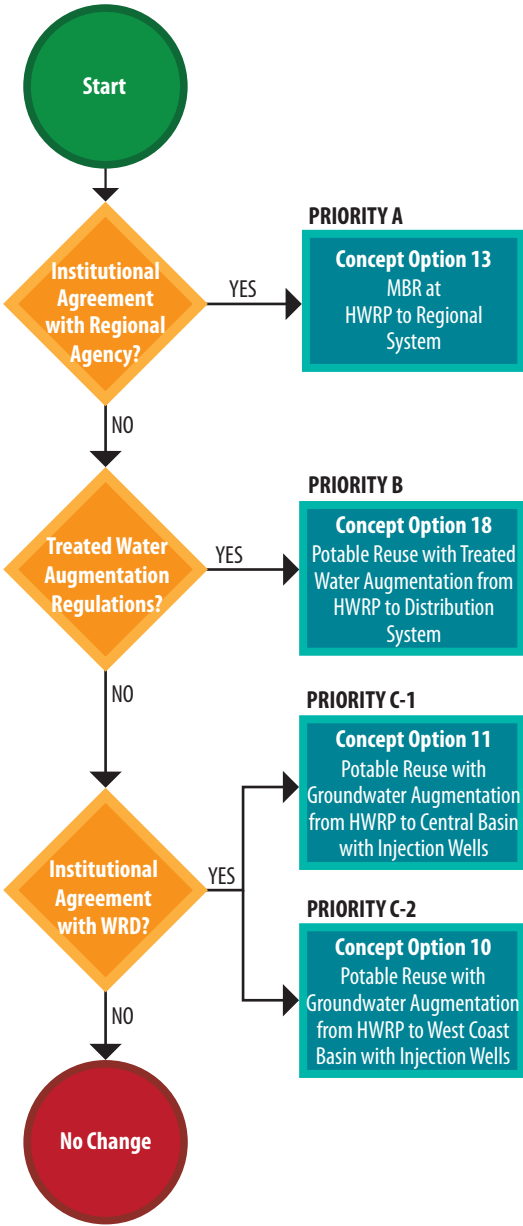

LEGEND & ACRONYMS

- ◆ Trigger
- Concept Option
- Flow Management Option

DCTWRP	Donald C. Tillman Water Reclamation Plant
GWR	Groundwater Replenishment Project
HWRP	Hyperion Water Reclamation Plant
LAGWRP	LA-Glendale Water Reclamation Plant
RWQCB	Regional Water Quality Control Board
TIWRP	Terminal Island Water Reclamation Plant
WRD	Water Replenishment District of Southern California

Disclaimer: At each trigger (decision point), evaluate all triggers and concept option priorities to consider changed circumstances in the future.

Figure 7.10
Trigger-Based Implementation Strategy for HWRP
One Water LA 2040 Plan
Summary Report

The most critical trigger for the Priority B Concept Option #18(HWRP to LADWP Distribution System) is the adopting potable reuse with treated water augmentation regulations that would allow this type of water reuse practice. If the potable regulations are not accepted within a desired timeframe, or if the City prefers a more conventional form of water reuse, the third-best potable reuse options from HWRP are Concept Options #10 and #11. These options consist of groundwater augmentation in the West Coast and Central Basin, respectively. Both options require an institutional agreement with WRD, who acts as the Watermaster for these two groundwater basins. In case such an agreement does not materialize and potable reuse regulations are not approved, it is recommended to postpone the implementation of a large scale potable reuse project from HWRP, which is indicated as "No Change" on Figure 7.10.

It can be concluded that all concept options involve the installation of additional treatment facilities at HWRP to deliver either MBR quality or advanced treated water for the various potable reuse project configurations. In addition, all selected concept options have the same capacity of 95,000 AFY. This capacity is based on the estimated available flow from HWRP for future water reuse projects after consideration of existing projects, already planned projects, estimated future flow increases, and treatment losses as shown in Table 7.7 and on Figure 7.11. For Concept Options #10 and #11, the total available flow of 95,000 AFY was proportionally allocated between the Central and West Coast Basins based on the estimated storage capacity of these basins.

Table 7.7 HWRP Flow Assumptions Summary Report One Water LA 2040 Plan	
Flow Component	Flow (mgd)
HWRP 2040 Project Influent Flow	283
In-Plant Uses	-36 ⁽¹⁾
Existing Delivery to West Basin	-35
Expanded Delivery to West Basin	-35
Hyperion AWP (HAWPF)	-1.5 up to -5
Expanded DCTWRP Water Reuse	-34
Expanded LAGWRP Water Reuse	-3
Potential Rancho Park WRF	-5
Brine Loss due to HAWPF (LAWA)	-0.2 up to -0.75
Brine Loss due to potential Advanced Water Purification Facility	-20 ⁽²⁾
Range of Available Flows for Water Reuse	109-133
Notes:	
(1) 25 mgd is used once through cooling at the HBEF. 11 mgd is used for other in-plant uses. 36 mgd non-recoverable at this time for recycling.	
(2) Based on assumed capacity of 85 mgd per Concept Option #13	

A conservative estimate of 85 mgd (95,000 AFY) was used to account for the remaining flows available at HWRP for reuse. This flow may vary due to conservation, and the amount of flow bypassed from the upstream plants. This value was used for the sizing of facilities and equipment that may be needed for each concept option. However, the concept options are preliminary in nature as the projects remain at a high level of definition. Further evaluation would be required should a concept option be implemented.

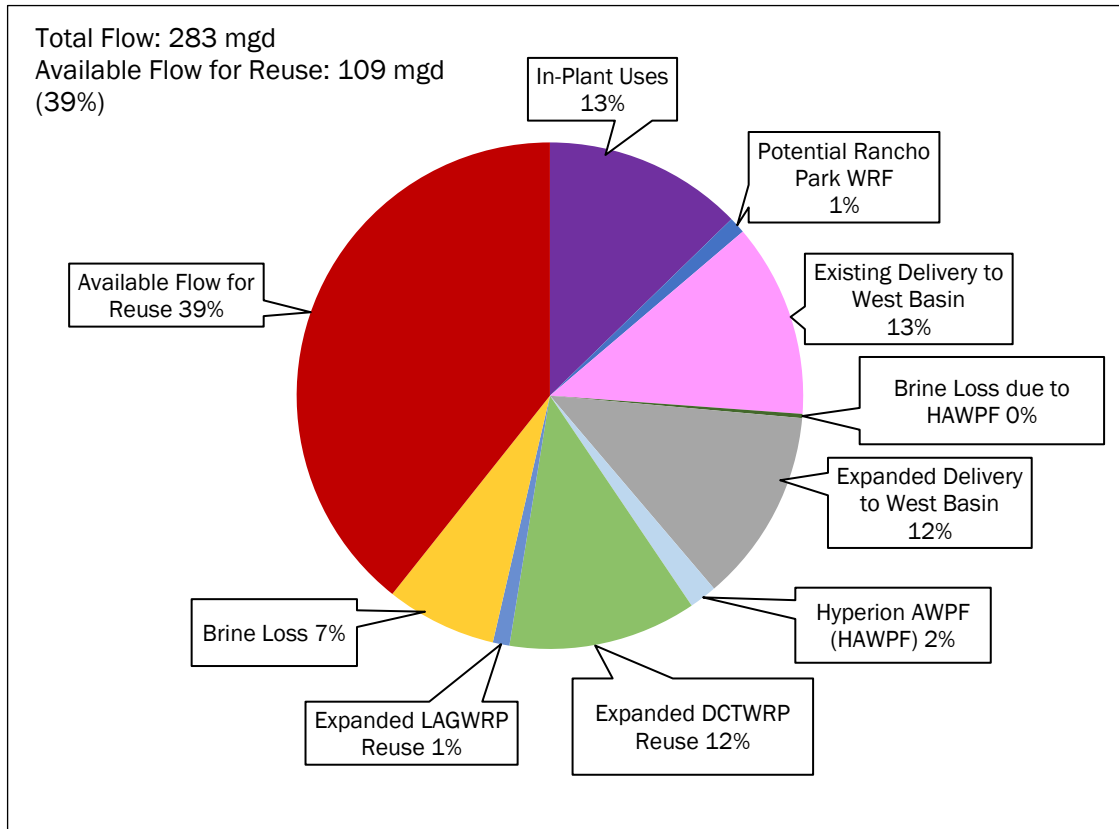

Figure 7.11 Estimated Flow Availability for Water Reuse from HWRP (2040 Projection)

In order to implement Concept Option #13 (MBR at HWRP to Regional System), HWRP process trains may need to be retrofitted for the installation of an MBR with a treatment capacity of 95,000 AFY (85 mgd). Additionally, it is estimated that a 25-MG primary effluent equalization tank may be required along with a large 13,000 horsepower (hp) pump station and a pipeline for conveyance. The length of the pipeline and pump station location would be determined by the connection location once a service agreement is established. An overall schematic of this concept option is shown on Figure 7.12. The proposed plant modifications to HWRP are shown on Figure 7.13.

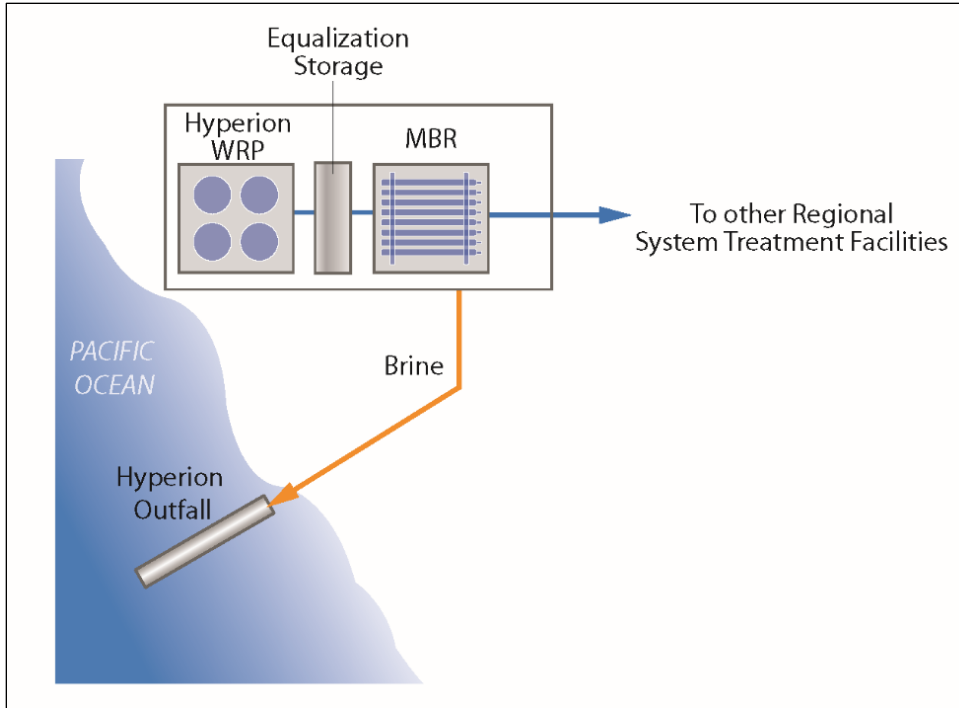

Figure 7.12 Process Flow Schematic for Concept Option #13 (MBR at HWRP to Regional System)

The location of the facilities presented on Figure 7.13 is preliminary in nature as the concept option definition remains at a high level. Details of the optimum project and location within the plant would need to be evaluated should this concept option be implemented.

Concept Option #13 (MBR at HWRP to Regional System) is a Priority A concept option. The key benefits associated with this concept option consist of:

- Maximizing HWRP's flows for reuse reducing discharge to the ocean
- Promotes collaboration with regional partners
- Delivers water to a regional system for reuse such as recharge into a groundwater basin that may be extracted for potable reuse and sold to water retailers at full service rates.

Moreover, this concept option helps fulfill the following One Water key objectives and guiding principles:

- Implement, monitor, and maintain a reliable wastewater system
- Improve local water supplies reliability
- Integrate management of water resources & policies
- Increase climate resilience

As such, the WRP portion of the concept option cost is included in the WWFP Adaptive CIP. The WWFP Adaptive CIP is discussed in further detail in Section 7.8 of this Chapter. Details of lower priority concept options for HWRP are discussed in the WWFP (see Volume 2).

Document Path: \\usinv1s01\GIS\GIS_Jobs\City_LA_BOS_MXD\Task7_TM\G\HWRP_PPEB_Metropolitan_20170914.mxd



- Proposed Facility
- Fine Screen
- Hyperion Recycled Water Pump Station
- MBR

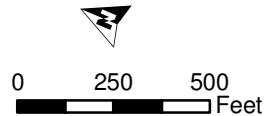

Figure 7.13 - Potential Upgrades for Concept Option #13 (MBR at HWRP to Regional System)
 One Water LA 2040 Plan
 Summary Report

7.5.2 DCTWRP

Six concept options that involve potable reuse with raw water augmentation, groundwater augmentation, treated water augmentation, LA river storage and use, and flow management from DCTWRP were evaluated. These concept options, shown in Table 7.8 were prioritized and the preferred concept options were identified.

The most critical trigger of any of the Priority A, B, or C option is the ability to increase recycled water flow availability to DCTWRP. Due to the success of water conservation and the ongoing groundwater replenishment project, all existing flows have been accounted for. Hence, the first trigger is a decision to pursue and implement a flow management project to divert additional wastewater flows to DCTWRP. Once the City makes this decision, the next trigger is the approval of a wastewater change petition from the Division of Water Rights per Water Code Section 1211 to allow a reduction in effluent discharge from DCTWRP to the LA River.

If this petition is approved, the City could proceed with Concept Option #26. By implementing some type of flow recirculation project for the Japanese Garden and Sepulveda Basin Lakes, a portion of the DCTWRP effluent that is currently discharged into the LA River could be repurposed for potable reuse.

If this petition is not approved, the City would need to proceed with Concept Option #22 and increase flow availability to DCTWRP by constructing the EWVIS project, which consist of a 6-mile sewer forcemain and six lift stations to bring wastewater flows from the eastern part of the San Fernando Valley to DCTWRP.

As shown on Figure 7.14, the next most critical triggers are related to the adoption of potable reuse regulations. The highest ranked potable reuse opportunity (Concept Option #15 - DCTWRP to LAAFP) would require acceptance of potable reuse with raw water augmentation, while the second highest concept option (#16 - DCTWRP to Distribution System) would require acceptance of potable reuse with treated water augmentation. In case the potable regulations are not accepted within a desired timeframe or if the City prefers a more conventional form of water reuse, the third best potable reuse option from DCTWRP is Concept Option #9 (Groundwater Augmentation from DCTWRP to San Fernando Basin Injection Wells). If none of the flow management strategies are feasible nor the potable reuse regulations are approved, it is recommended to postpone any new water recycling projects from DCTWRP. This decision is indicated as "No Change" on Figure 7.14.

Table 7.8 DCTWRP Concept Options Summary Report One Water LA 2040 Plan					
Concept Option #	Title	Strategy	Estimated Yield (Normal Year)	Capital Cost (\$M)⁽¹⁾	Unit Cost (\$/AF)
7	Upper Los Angeles River to DCTWRP	LA River Storage and Use	5,600 AFY (5 mgd)	\$18	\$160
9	DCTWRP to San Fernando Basin Injection Wells	Potable Reuse with Groundwater Augmentation	15,000 AFY (14 mgd)	\$360	\$1,600
15	DCTWRP to Los Angeles Aqueduct Filtration Plant	Potable Reuse with Raw Water Augmentation	15,000 AFY (14 mgd)	\$310	\$1,500
16	DCTWRP to LADWP Distribution System	Potable Reuse with Treated Water Augmentation	15,000 AFY (14 mgd)	\$295	\$1,300
22	East-West Valley Interceptor Sewer	Flow Management	12,800 AFY (11.41 mgd)	\$85	\$430
26	Japanese Garden & Sepulveda Basin Lakes Recirculation	Flow Management	20,000 AFY (18 mgd)	\$20	\$70

Notes:

(1) Total Concept Option cost includes a variety of project components including treatment facilities, conveyance, and injection and extraction facilities. Not all costs pertain to the Wastewater Facilities Plan.

(2) Bold indicates a Priority A Concept Option

Donald C. Tillman Water Reclamation Plant

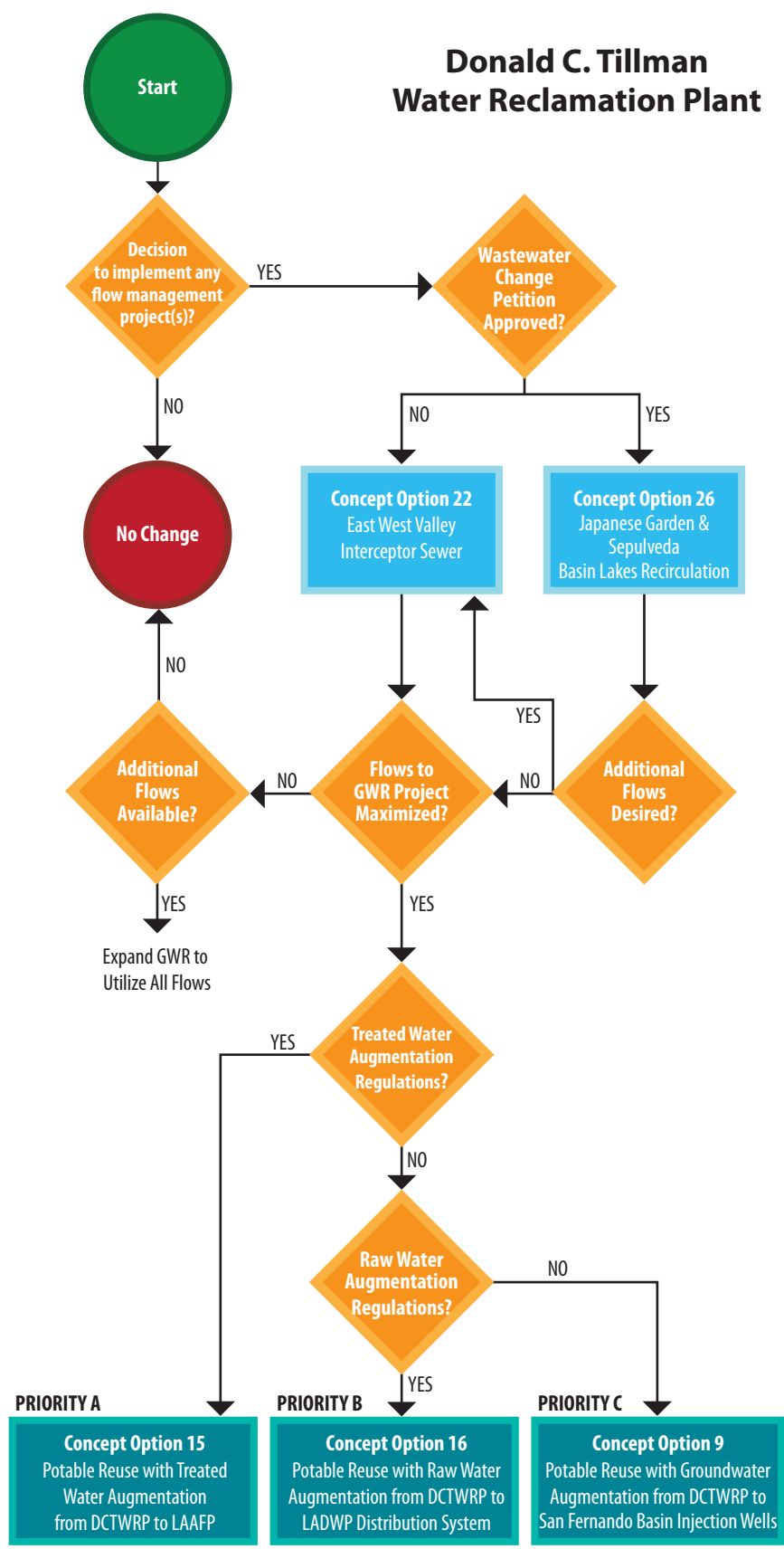

LEGEND & ACRONYMS

- ◆ Trigger
- Concept Option
- Flow Management Option

DCTWRP Donald C. Tillman Water Reclamation Plant
 GWR Groundwater Replenishment Project
 HWRP Hyperion Water Reclamation Plant
 LAGWRP LA-Glendale Water Reclamation Plant
 RWQCB Regional Water Quality Control Board
 TIWRP Terminal Island Water Reclamation Plant
 WRD Water Replenishment District of Southern California

Disclaimer: At each trigger (decision point), evaluate all triggers and concept option priorities to consider changed circumstances in the future.

Figure 7.14
Trigger-Based Implementation Strategy for DCTWRP
 One Water LA 2040 Plan
 Summary Report

The total capacity of the water reuse options from DCTWRP may be constrained by total flow availability and capacity of the plant. As shown on Figure 7.15, the estimated flow available for water reuse after the consideration of existing projects is approximately 18 mgd. This is substantially less than the average flow of 53 mgd listed in Table 7.1 because flows are already allocated to uses identified in Table 7.9.

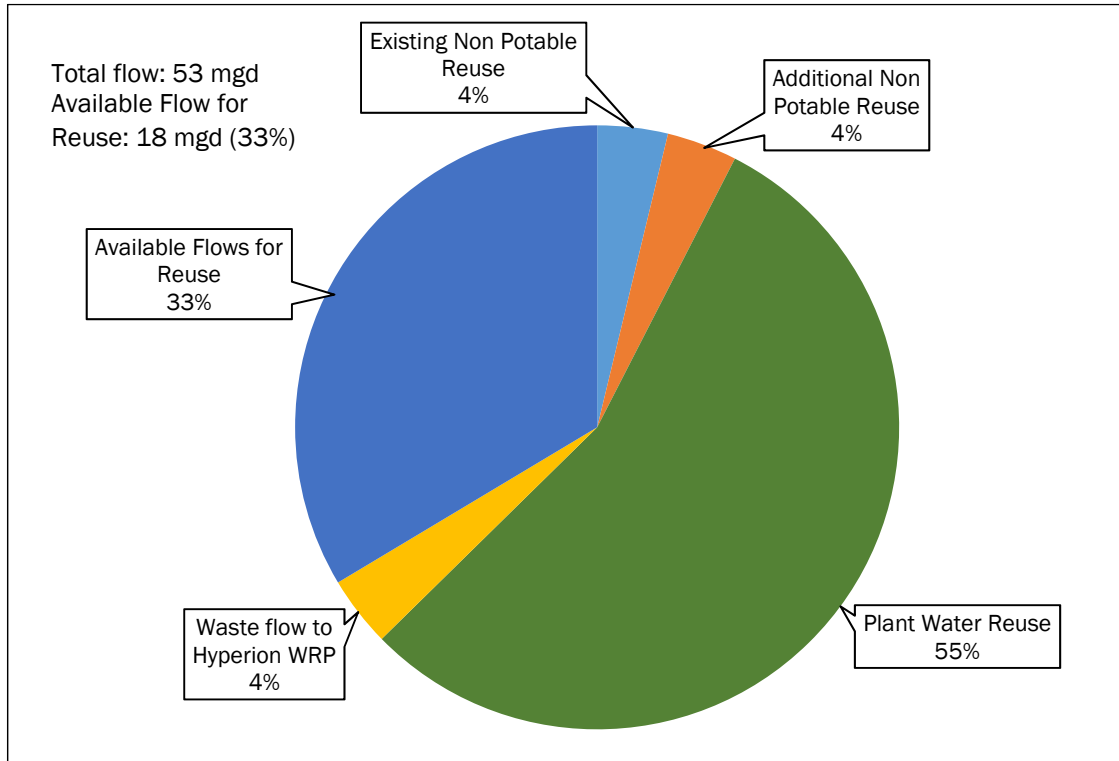

Figure 7.15 Estimated Flow Availability for Water Reuse from DCTWRP (2040 Projection)

Table 7.9 DCTWRP Flow Assumptions Summary Report One Water LA 2040 Plan	
Flow Component	Flow (mgd)
DCTWRP 2040 Project Influent Flow	53
Existing Non Potable Reuse	-2
Additional Non Potable Reuse	-2
Plant Water Reuse ⁽¹⁾	-29.3 to -11.2
Waste flow to HWRP	-2
Range of Available Flows for Water Reuse (without GWR)	18-36
GWR Phase 1 ⁽²⁾	-27
Brine Loss from Advanced Water Purification Facility ⁽²⁾	-9
Range of Additional Flow Diversion Needed (with GWR)	0-18
<u>Notes:</u>	
(1) This value could be reduced from 29.3 mgd to as low as 11.2 mgd through implementation of Concept Option #26 (Japanese Garden & Sepulveda Basin Lakes Recirculation).	
(2) Implementation of the GWR AWPf may require the diversion of additional flow to DCTWRP. For this reason, the flow allocated for these items (total of 36 mgd) has not been deducted from the available flows for water reuse.	

For planning purposes it was assumed that approximately 14 mgd could be diverted to DCTWRP and therefore 14 mgd (15,000 AFY) was estimated to be the remaining flow available at DCTWRP for reuse. This value was used for the sizing of facilities and equipment that may be needed for each concept option. However, the concept options are preliminary in nature as the projects remain at a high level of definition. Further evaluation would be required should a concept option be implemented.

Implementation of either concept option may require upgrades to either the plant or the system. Implementation of the EWWIS could require additional lift stations, diversion structures, and multiple pipelines. Conveyance of flows would require 6 miles of force main pipelines, varying in diameter from 24-inch to 42-inch. A total of 6 diversion structures would be needed, in addition to the 6 new lift stations to convey flows to DCTWRP. This concept option would likely not require any immediate changes within DCTWRP. An overall concept flow schematic is shown on Figure 7.16.

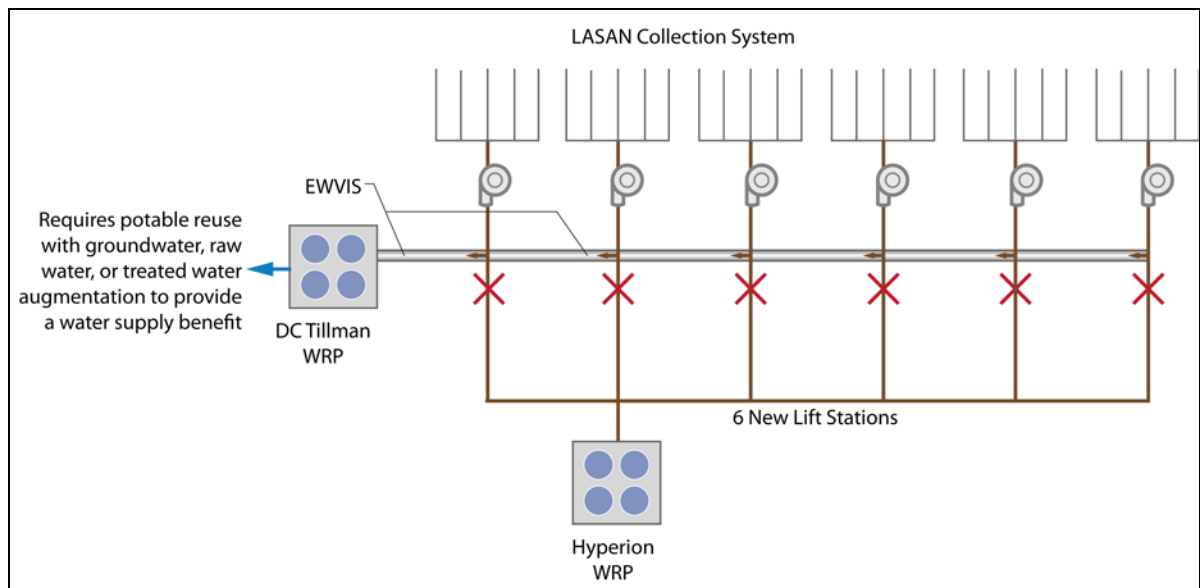

Figure 7.16 Process Flow Schematic Concept Option #22 (East-West Valley Interceptor Sewer)

The implementation of Concept Option #15 (DCTWRP to LA Aqueduct Filtration Plant) may require an additional 14 mgd of AWP (beyond the GWR project), and 2 MG tertiary equalization tank. To connect to the LADWP distribution system one 2,500 horsepower pump and 8 miles of 36-inch diameter pipe may be needed. An overall flow schematic of this concept option is shown on Figure 7.17. The potential areas for expansion at DCTWRP are shown on Figure 7.18. Figure 7.18 also shows the potential AWP expansion location in addition to the planned expansion areas in accordance with the US Army Corps of Engineers (USACE) lease.

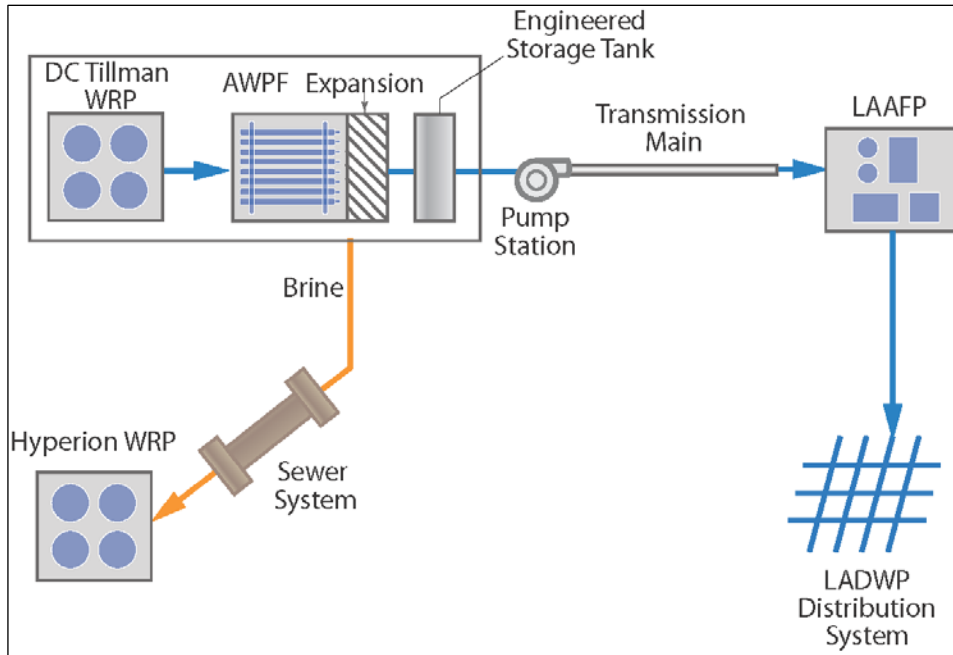

Figure 7.17 Process Flow Schematic for Concept Option #15 (DCTWRP to LAAFP)

The key benefits associated with Concept Option #15 (DCTWRP to LA Aqueduct Filtration Plant) and Concept Option #22 (East West Valley Interceptor Sewer) are summarized below.

Concept Option #15:

- Expands use of potable reuse with raw water augmentation
- Increases DCTWRP's water reuse flows

Concept Option #22:

- Maximizes City water reclamation plants' available treatment, recycling, and potable reuse capacity (i.e. direct water where it is needed) by redirecting wastewater from one sewershed to another

Moreover, both of these concept options help fulfill the following One Water key objectives and guiding principles:

- Implement, monitor, and maintain a reliable wastewater system,
- Improve local water supplies and reliability
- Integrate management of water resources and policies
- Increase climate resilience

The WRP portion of the costs associated with the implementation of Concept Option #15 (DCTWRP to LA Aqueduct Filtration Plant) and Concept Option #22 (East West Valley Interceptor Sewer) are included in the WWFP Adaptive CIP. The WWFP Adaptive CIP is discussed in further detail in Section 7.8. Details of the other concept options are discussed in the WWFP (see Volume 2).

Document Path: \\usnr\1s07\GIS\Jobs\City_LA_BOS\MXDs\OneWater_LA2040Plan\WRP\DCTWRP_ExpansionArea_LtrL_20170914.mxd

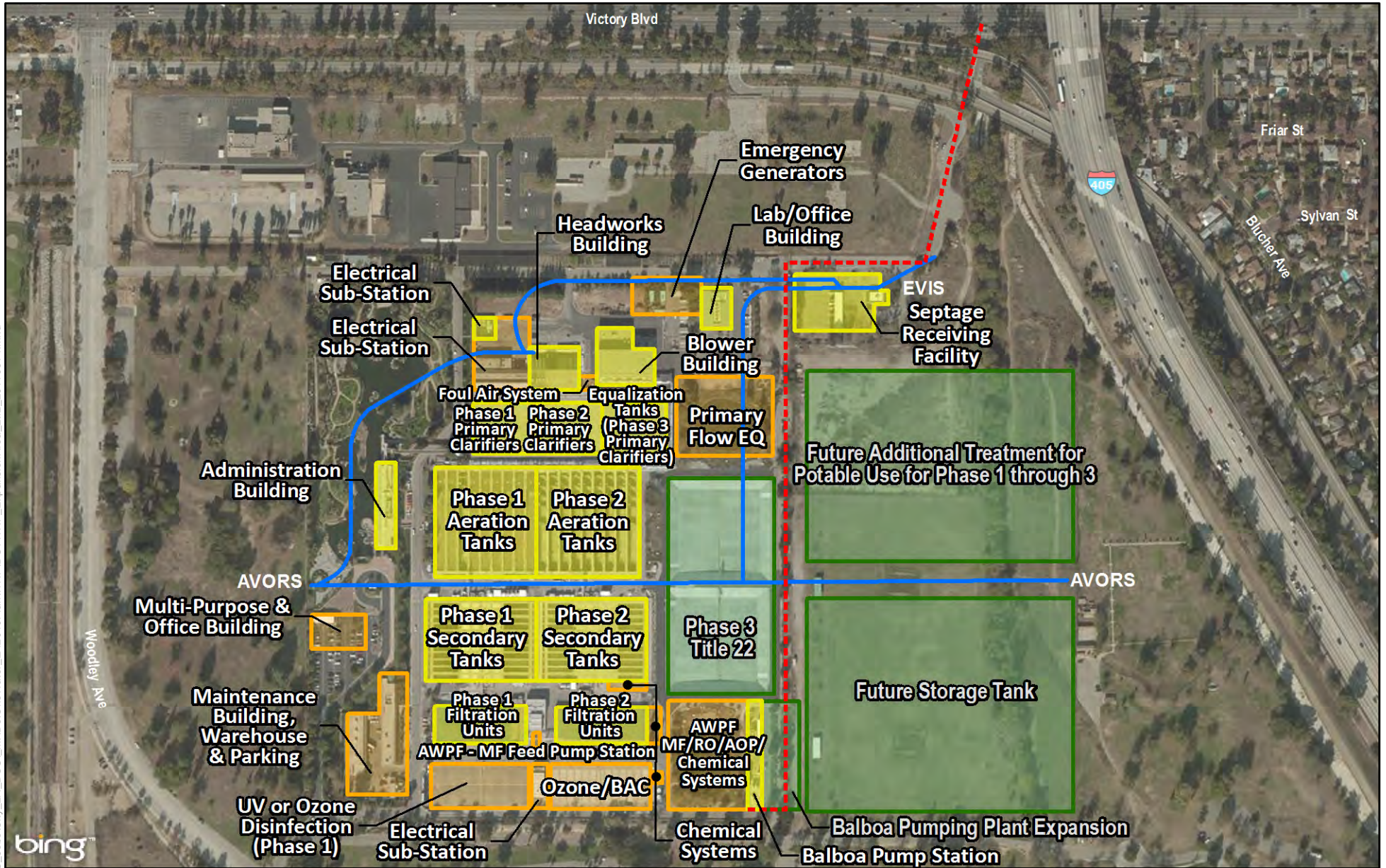

- - - Proposed Brine Line
- AVORS and EVIS
- Existing Facility
- Year 2025 Facility
- Long Term Expansion

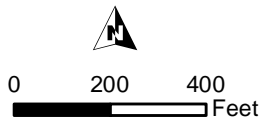

Figure 7.18 - Potential Expansion Areas for Concept Option #15 (DCTWRP to LAAFP)
 One Water LA 2040 Plan
 Summary Report

7.5.3 LAGWRP

Two concept options were identified and evaluated for the LAGWRP as part of the future strategies previously described. These concept options, shown in Table 7.10 were prioritized and the preferred concept option (Priority A) was identified as Concept Option #17 (LAGWRP to Headworks Reservoir). The most critical trigger, as shown on Figure 7.19 for this concept option is adopting potable reuse with treated water augmentation regulations that would allow this type of water reuse practice.

If the potable regulations are not accepted within a desired timeframe, or if the City prefers a more conventional form of water reuse, the Priority B Concept Option #23 (NPR expansion beyond 2015 UWMP) could be considered for the remaining available flows. The most critical trigger for this option is new customer demand that is cost-effective to serve, considering the customer’s location, demand size, demand variability, and water quality requirements.

Table 7.10 LAGWRP Concept Options Summary Report One Water LA 2040 Plan					
Concept Option #	Title	Strategy	Estimated Yield (Normal Year)	Capital Cost (\$M)⁽¹⁾	Unit Cost (\$/AF)
17	LAGWRP to Headworks Reservoir	Potable Reuse with Treated Water Augmentation	6,000 AFY (5 mgd)	\$140	\$1,500
23	Increase Recycled Water Demand beyond 2015 UWMP	Non-Potable Reuse	3,500 AFY (3 mgd)	\$70 ⁽²⁾	\$2,100

Notes:

- (1) Total Concept Option cost includes a variety of project components including treatment facilities, conveyance, and injection and extraction facilities. Not all costs pertain to the Wastewater Facilities Plan.
- (2) This capital cost reflects the proportion of costs specifically for LAGWRP to implement Concept Option #23 (Increase Recycled Water Demand beyond 2015 UWMP). The cost was calculated using proportions of yield and cost relative to overall concept implementation cost.
- (3) Bold indicates a Priority A Concept Option

LA-Glendale Water Reclamation Plant

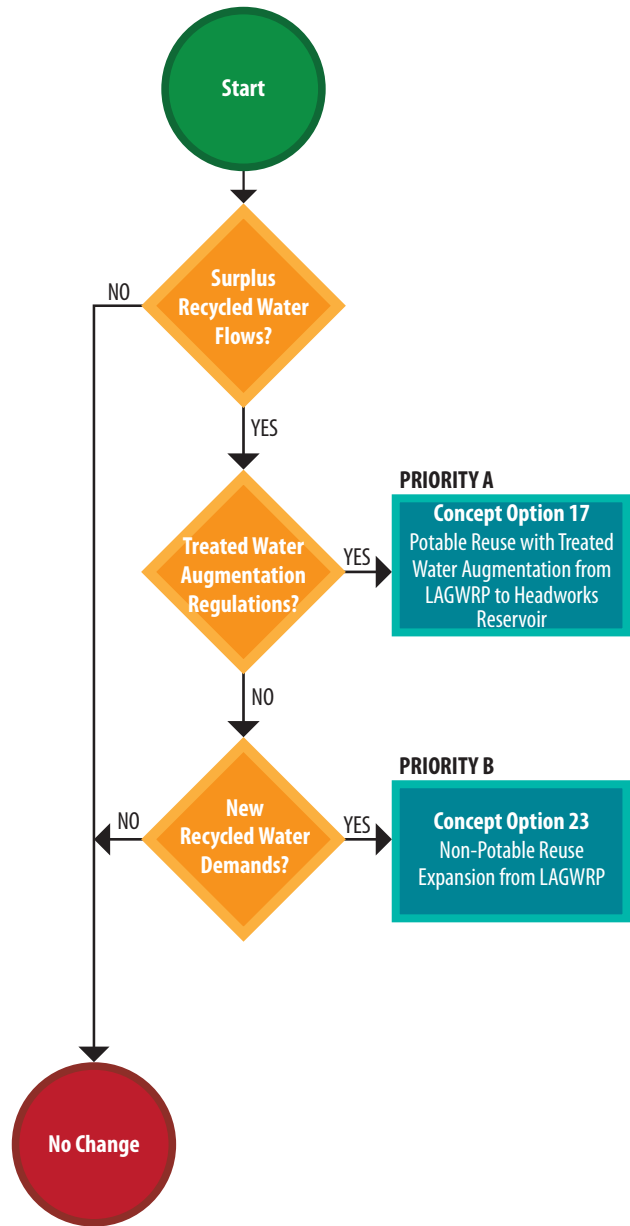

LEGEND & ACRONYMS

- ◆ Trigger
- Concept Option
- Flow Management Option

DCTWRP	Donald C. Tillman Water Reclamation Plant
GWR	Groundwater Replenishment Project
HWRP	Hyperion Water Reclamation Plant
LAGWRP	LA-Glendale Water Reclamation Plant
RWQCB	Regional Water Quality Control Board
TIWRP	Terminal Island Water Reclamation Plant
WRD	Water Replenishment District of Southern California

Disclaimer: At each trigger (decision point), evaluate all triggers and concept option priorities to consider changed circumstances in the future.

Figure 7.19
Trigger-Based Implementation Strategy for LAGWRP
One Water LA 2040 Plan
Summary Report

The concept options consist of various potable reuse options. The estimated yield associated with the potable reuse options is dependent on the quantity of LAGWRP flows available for water reuse. The estimated available flow for additional water reuse is limited to roughly 5 mgd or 6,000 AFY. This is due to the flows that are already allocated to the uses identified in Table 7.11 and Figure 7.20.

Table 7.11 LAGWRP Flow Assumptions Summary Report One Water LA 2040 Plan	
Flow Component	Flow (mgd)
LAGWRP 2040 Project Influent Flow	22
City of Glendale ⁽¹⁾	-11
In-Plant Uses	-0.8
NPR Demands	-4
Waste Discharge and Bypass to HWRP	-0.5
Range of Available Flows for Water Reuse	0-5.7
Note: (1) City of Glendale co-owns LAGWRP, Glendale is entitled to 50% of the flows	

A conservative estimate of 5 mgd was used to account for the remaining flows available at LAGWRP for water reuse. This flow may vary due conservation, and the amount of flow bypassed to HWRP. This value was used for the sizing of facilities and equipment may be needed for each concept option as discussed in greater detail in the WWFP (Volume 2).

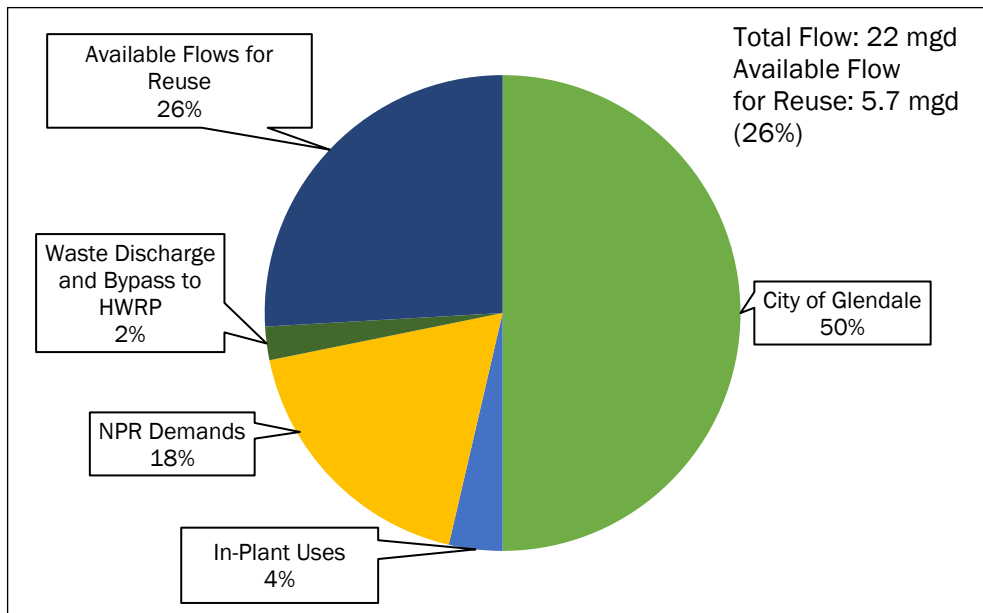

Figure 7.20 Estimated Flow Availability for Water Reuse from LAGWRP (2040 Projection)

The implementation of Concept Option #17 (LAGWRP to Headworks Reservoir), assumes a 5 mgd AWPf would treat the recycled water to achieve potable reuse with treated water augmentation requirements at the time of project implementation. These processes have been assumed to consist of ozone/biologically active filters (O₃/BAF), ultrafiltration (UF), RO, and UV/AOP. A 1 MG engineered

storage tank would also be required to provide 3 hours of detention time. Brine disposal is assumed to utilize the existing sewers to HWRP. Per discussions with City staff, a potential alternative location for the AWPf could be adjacent to the Headworks Reservoir. The feasibility of this alternative location could be evaluated in the future.

A new 200 horsepower pump station would also be constructed to convey the product water to the Headworks Reservoir. Pipeline would be 4 miles and 24 inches in diameter. Figure 7.21 shows an overall concept schematic with the aforementioned components may be needed for implementation.

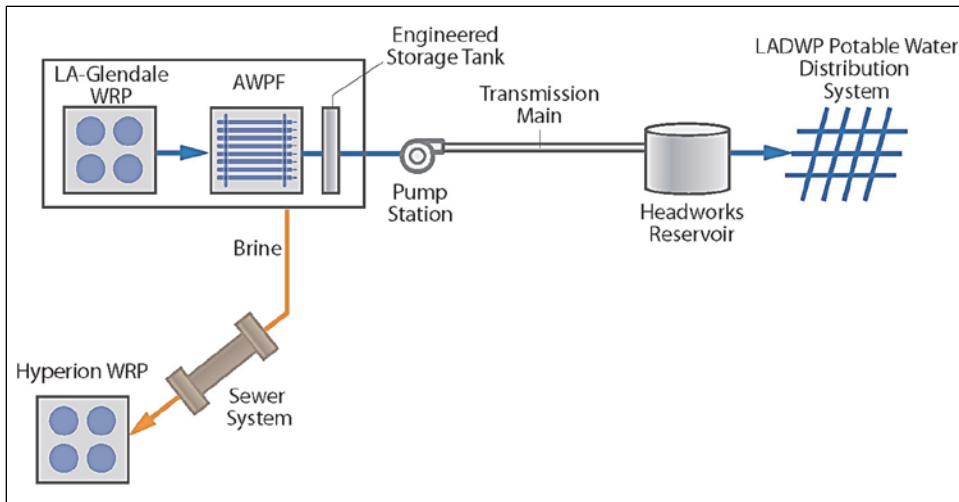

Figure 7.21 Process Flow Schematic Concept Option #17 (LAGWRP to Headworks Reservoir)

Potential locations of the AWPf, storage tank and pump station are shown on Figure 7.22 however the final location of these upgrades would be determined during detailed design should this concept option be selected for implementation. Instead of siting the AWPf at LAGWRP, an AWPf could be sited at the Headworks Reservoir, however, this siting location was not part of this evaluation, and further studies are required.

The key benefits associated with this concept option consist of:

- Expands LAGWRP's treatment technology and increases flow available for water reuse
- Expands use of potable reuse with treated water augmentation

Moreover, this concept option helps fulfill the following One Water key objectives and guiding principles:

- Implement, monitor, and maintain a reliable wastewater system
- Improve local water supplies reliability
- Integrate management of water resources and policies
- Increase climate resilience

The WRP portion of the cost associated with the implementation of Concept Option #17 (LAGWRP to Headworks Reservoir) is included in the WWFP Adaptive CIP. The WWFP Adaptive CIP is discussed in further detail in Section 7.8. Details of the other concept options are discussed in the WWFP (see Volume 2).





-  Upcoming Project
-  Potential AWWPF Location

Figure 7.22 - Potential Process Location for Concept Option #17 (LAGWRP to Headworks Reservoir)
One Water LA 2040 Plan
Summary Report

7.5.4 TIWRP

Currently the majority of the plant flow is treated and reused. Additionally, future projected tributary flow increases are limited. Due to these considerations, the estimated available flow for additional water reuse is constrained. As a result, no concept options were identified for TIWRP. A breakdown of the allocated flows and potential remaining flows available for reuse are detailed in Table 7.12 and Figure 7.23.

Table 7.12 TIWRP Flow Assumptions Summary Report One Water LA 2040 Plan	
Flow Component	Flow (mgd)
TIWRP 2040 Project Influent Flow	18
Brine Loss due to AWPf	-3.6
Dominguez Gap Barrier	-7.5
Machado Lake	-0.2
Harbor Other Users	-0.5
Industrial Users and Future Users	-2.5 up to -3.5
Range of Available Flows for Water Reuse	2.7 - 3.7

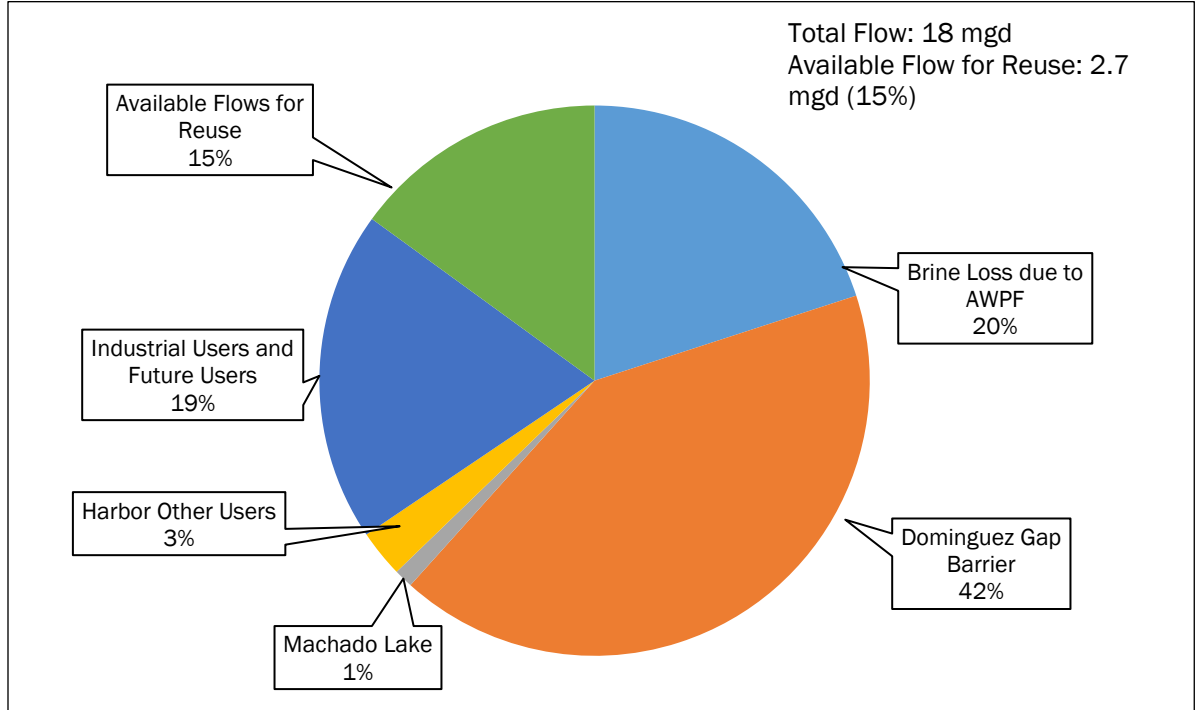

Figure 7.23 Estimated Flow Availability for Water Reuse from TIWRP (2040 Projection)

7.5.5 Potential Future Water Reclamation Plant Options

In addition to the four existing WRPs, the opportunities and benefits to construct one or more new WRPs was evaluated as part of the Plan. Based on the analysis, it was concluded that the most beneficial location to potentially add a new WRP is to construct one or more new facilities near Rancho Park in West LA. This project was also identified as one of the top, current integration opportunities as described in Chapter 5.

Although this project concept is still under development, the current conceptual project components of the Rancho Park Water Reclamation Facility project include:

- Component 1 – Stormwater capture and treatment system to supplement irrigation demands at the Rancho Park Golf Course and Cheviot Hills Recreation Center.
- Component 2 – Satellite WRP to meet non-potable demands in the regional service area, including potential recycled water delivery to the UCLA campus.
- Component 3 – Expansion of satellite WRP to meet peak seasonal non-potable demands in the regional service area.

The Rancho Park Water Reclamation Facility project would produce recycled water. The recycled water would be augmented with dry weather runoff and stormwater, when available, to serve non-potable water demands near Rancho Park (West LA). LASAN would lead the project, while LADWP and Los Angeles Department of Recreation and Parks (RAP) would be supporting agencies. This integrated approach would be a multi-benefit project that:

1. Produces recycled water to meet substantial non-potable demands in the Westside area, including industrial uses and irrigation for the UCLA campus, the City's largest municipal golf course, and several other users.
2. Captures stormwater to retain, treat, and remove pollutants such as trash, metals, and bacteria.
3. Increases reliability of supply by being locally sourced and climate resilient.

Successful implementation of this project requires thoughtful, proactive communication both within City government and with the surrounding community.

7.5.6 On-Site Treatment

On-site treatment facilities (OSTFs) are small facilities at point-of-use locations. OSTFs would be located upstream of one of the City's water reclamation plants to serve specific non-potable water demands or potentially for localized groundwater replenishment. OSTFs could be owned by the City or private entities and may or may not include solids treatment. LASAN does not currently have a policy that regulates or prevents other entities from performing on-site treatment.

Additional OSTFs could be implemented throughout the City service area and serve the local needs of smaller areas. Demands for this water could come from industries who may have recycled water uses. However, complete bypass around the OSTF and back-up potable water supplies would be required to ensure failsafe disposal during process upsets or facility maintenance. New on-site

treatment facilities could potentially have financial impacts due to declining revenues, as well as consequences for treatment and conveyance due to changes in wastewater quality, such as biological oxygen demand (BOD) and total suspended solids (TSS) concentrations. This analysis is included in TM 12.5.1, 12.5.2 and 12.5.3 – Task 12 Special Studies On-Site Treatment (see Volume 8).

In addition to the wastewater projects in the WCIP and the recommended concept options, the One Water LA policies outline strategies for developing guidelines for Onsite Treatment Facilities (OSTFs). Two of the recommended policies for these OSTFs include:

1. Development of guidelines that protect public health and outline operations of wastewater and recycled water systems (#38); and
2. A fee structure and payment guidelines that reflect collection and treatment system impacts and costs (#39).

Stakeholders also recommended expanding education and engagement programs on Potable Reuse (#35). A full list of the policies and action items can be found in Chapter 9 and Appendix F of the Summary Report.

7.6 BIOSOLIDS MANAGEMENT

Biosolids processing at a treatment plant is integral to the achievement of regulatory compliance for effluent quality, solids diversion/reuse, and air emissions. In recent years, regulatory drivers and public perception have further accentuated the importance of the biosolids processing component of wastewater management to successful system operation. The City is one of the largest wastewater treatment agencies in Southern California and as such the management of biosolids is critical.

Currently, LAGWRP and DCTWRP do not have solids handling facilities, instead both facilities convey solids to the HWRP. HWRP and TIWRP have onsite systems to process biosolids and facilitate their beneficial reuse. TIWRP has changed from land applying Class A biosolids cake at a site in Maricopa County, Arizona to utilizing the TIRE demonstration project for 100 percent of the biosolids produced at TIWRP along with a portion of the biosolids from HWRP. HWRP land applies Class A biosolids to the Green Acres Farm. Both plants meet quality requirements dictated by regulatory standards for the respective approaches to biosolids reuse/diversion.

Potential changes in biosolids management need to be further studied and reviewed in the development of any long term plan to assist the City in developing a diverse portfolio of effective options in both the near term and long term. This diverse portfolio would incorporate flexibility to adjust to future changing conditions.

7.7 CLIMATE RISK ASSESSMENT FOR WASTEWATER INFRASTRUCTURE

Climate change will likely increase annual average temperatures, precipitation patterns, extreme rain events and sea level rise. These trends could result in damages at wastewater treatment plants and/or conveyance facilities. To proactively manage these risks, a climate change risk assessment was performed for each of the WRPs, consisting of scenario development, screening analysis, site visits, risk analyses, and adaptation planning alongside LASAN staff. The assessment performed also included use of the US EPA's Climate Resilience Evaluation and Awareness Tool (CREAT) to identify potential climate change scenarios and risk assessment. Climate risk and resilience analysis requires additional assessment and modifications to planning, design, and construction of infrastructure. Site visits and inspections of the WRPs and below-ground pumping facilities were used to assess climate change risks and vulnerabilities. Hazards identified for WRP assets were:

- 500 year Flood Zone (Elevation: 12.25 feet)
- Tsunami (Elevation: approximately 20 feet)
- Sea level rise of 0.5-1.5 meters based on Coastal Storms Modeling System (CoSMoS) (Elevation: 11.64 – 14.92 feet)

Based on the hazards identified Damage Threshold Elevations were also identified:

- Door Elevation: 11.17 feet
- Generator Pad Elevation: 11.89 feet

These elevations were used to determine the WRP assets that were at risk. Subsequently, practical improvements were identified to mitigate these risks, such as:

- Install watertight connections
- Waterproof instrumentation and controls
- Add backup power generation
- Construct floodwalls and flood gates
- Raise mechanical and electrical equipment to avoid flooding

The identified climate resilience improvements were included in the CIP of each WRP as presented in Section 7.8. A more detailed description of the climate risk assessment of wastewater infrastructure is included in the Chapter 10 of this Volume, while a similar analysis of stormwater infrastructure is included in the Stormwater and Urban Runoff Facilities Plan (see Volume 3). The complete analysis is included in the Climate Risk and Resilience Assessment for Wastewater and Stormwater Infrastructure (see Volume 6).

7.8 WASTEWATER FACILITIES ADAPTIVE CAPITAL IMPROVEMENT PLAN

The WWFP Adaptive CIP combines the identified capital improvement projects for both the wastewater collection system and the four WRPs, as well as In-Progress Projects and concept options to create a comprehensive CIP. The purpose of this WWFP Adaptive CIP is to help guide the City with prioritization, decision making, and implementation of projects that align with the City's long-term vision.

7.8.1 Cost Estimating Assumptions

Four primary sources of information and costing were integrated to develop the WWFP Adaptive CIP. These sources are:

1. Los Angeles Bureau of Engineering (LABOE) Uniform Project Reporting System (UPRS) – The UPRS is the publicly available source for project documented in the WCIP and other sources. The UPRS was used in conjunction with the WCIP to cross reference project for inclusion in the WWFP Adaptive CIP.
2. LASAN Wastewater Capital Improvement Plan (WCIP) - The WCIP includes capital developed for the City's Clean Water facilities. The projects included in this document have been approved by the City's Program Review Committee, comprised of Assistant Directors of LASAN and a Deputy City Engineer. The administration, coordination, and implementation of the projects in the 10-Year (FY 2015/16-2024/25) WCIP are assigned to various divisions of LASAN and BOE in the Department of Public Works. The Program includes replacement, rehabilitation, and expansion of the City's wastewater treatment and collection system facilities.
3. Los Angeles Department of Water and Power (LADWP) 2015 UWMP - Every five years LADWP develops a new UWMP that documents the City's efforts since the previous document, updates goals for the next 25 years, and identifies changes since the previous document.
4. Future Integration Opportunities - These opportunities (also referred to as concept options) were developed as part of the Plan and are described in Chapter 6.

The capital costs for the concept options were developed using assumed treatment components of the WRPs and assumed unit costs. These costs are based on industry standards and include construction contingencies. Land acquisition costs are not included and all costs have a 2.0 multiplier as these projects are preliminary in nature. All costs are reported in 2017 dollars.

After the compilation of the data, the CIP was reviewed. In areas where no or a low estimate was reported, implying little or no planned costs, further analysis was undertaken. Methodologies were employed to provide projections for future costs. Details of these methodologies are described in Chapter 11 of Volume 2.

In addition to the above sources, discussions were held with Plant Managers and their staff regarding their views and recommendations for their respective water reclamation plant CIP.

7.8.2 CIP Planning Phases and Project Categories

The WWFP Adaptive CIP is separated into the following three distinct planning phases:

- **Near-term:** This planning phase includes projects that are planned for the 3-year period from 2018 to 2020.
- **Mid-term:** This planning phase includes projects that are planned for the 10-year period from 2021 to 2030.
- **Long-term:** This planning phase includes projects that are planned for the 10-year period from 2031 to 2040.

In addition to the 3 planning phases, the CIP is also organized by the following five project categories:

- **Capital Projects from WCIP** – These projects were previously identified in the WCIP. These projects include new construction, expansion, or renovation that helps maintain or improve a City facility or infrastructure that may be funded by the Capital Budget.
- **Replacement and rehabilitation Projects from WCIP** – These projects were previously identified in the WCIP. These projects are required for the continued operation of the facility in its present form.
- **Climate Resiliency Projects** – These are projects developed as part of the Plan and identified in Volume 6 Climate Risk and Resilience Assessment for Wastewater and Stormwater Infrastructure. These projects are needed to adapt to environmental conditions due to climate change
- **Projected Capital Projects** – These are projects not identified in the WCIP and are projected as part of the WWFP in collaboration from City staff. These projects include new construction, expansion, or renovation that helps maintain or improve a City facility or infrastructure that may be funded by the Capital Budget. Project costs were estimated using a methodology described in Chapter 11 of Volume 2.
- **Projected replacement and rehabilitation Projects** – These are projects not identified in the WCIP and are projected as part of the WWFP in collaboration with City staff. These projects may be needed for the continued operation of the facility in its present form. These projects were estimated using the methodology in Chapter 11 of Volume 2.

The following subsections present components of the WWFP Adaptive CIP, starting with the In-Progress Projects, followed by the current integration opportunities, future integration opportunities (concept options) and the Estimated and Projected CIP.

7.8.3 In-Progress Projects

In-Progress Projects are defined as planned supply projects or programs for groundwater, recycled water, and stormwater that are expected to be implemented outside and independent of the Plan. Table 7.13 summarizes the In-Progress Projects, estimated capital costs, projected construction completion, and resulting phase. Additional details of the In-Progress Projects can be found in TM 5.2 (see Volume 5).

Table 7.13 Summary of In Progress Project Estimated Costs			
Summary Report			
One Water LA 2040 Plan			
In-Progress Projects	Estimated Capital Cost Estimate (\$2017) Millions	Year Complete	Phase
Advanced Treated Recycled Water Delivery to LAX and Scattergood Generating Station	\$38 ⁽¹⁾	2019-2020	Near
HWRP Delivery Expansion to 70 mgd for WBMWD and LA Harbor Area	\$16 ⁽²⁾	2020	Near
DCTWRP Groundwater Replenishment Project with AWPf	\$370 ⁽³⁾	2023	Near/Mid
LAGWRP Increase Recycled Water Demand beyond 2015 UWMP	\$73	2018-2020	Near
TIWRP AWPf Expansion to 12 mgd (Completed in 2017)	\$n/a ⁽⁴⁾	Mid-2017	Near
Total	\$497		
Notes:			
(1) Cost of phase 1 of this project is estimated at \$38 million, scheduled to occur in the near-term. Expansion of additional 3.5 mgd (product water) could occur in the mid-term, for an estimated capital cost of \$92 million for a total capital cost of \$130 million.			
(2) The estimated capital cost is for the expansion of the pump station and does not include WBMWD's costs. An additional cost of \$400 million could be incurred in the future should 70 mgd of MBR treatment be installed at HWRP.			
(3) Groundwater Replenishment Project with AWPf identified by a WCIP. Phasing will be split into near term and mid-term.			
(4) TIWRP Expansion to 12 mgd was completed during the finalization of the WWFP. For this reason, it has not been included in the total cost of the In-Progress Projects.			

The City is demonstrating a commitment to focus significant resources on alternative water supply sources through the implementation of In-Progress projects such as the Groundwater Replenishment Project with AWPf at DCTWRP and the Advanced Treated Recycled Water Delivery to LAX and Scattergood Generating Station.

7.8.4 Current Integration Opportunities

Another component of the WWFP Adaptive CIP is the current integration opportunities, such as future WRPs. New water reclamation plants are being considered to provide satellite treatment in communities with limited access to reclaimed water and a proven cost effective demand for its use. One option for a new plant is in the Rancho Park area, which would provide a stormwater capture and treatment system along with one or more satellite WRP(s) to meet non-potable demands in the regional service area. The estimated project cost is approximately \$58 million, which does not include the cost of the recycled water conveyance system.

City staff has continued the feasibility evaluation of this project and discussions between LASAN, LADWP, and the department of Recreation and Parks (RAP) are ongoing. This project provides the following benefits:

- Production of recycled water to meet substantial non-potable demands in the Westside area, including industrial uses and irrigation for the UCLA campus, the City's largest municipal golf course, and several other users.
- Capture of stormwater to retain, treat, and remove pollutants such as trash, metals, and bacteria.
- Increased reliability of supply by being locally sourced and climate resilient.

Although the project configuration is still subject to change, there is no new report or cost estimate for this project at the time of this plan development. Hence, the cost estimate of \$58 million will be used in the WWFP Adaptive CIP.

7.8.5 Future Integration Opportunities

The future integration opportunities analysis yielded the concept options discussed in Section 7.5. These concept options are another component of the WWFP Adaptive CIP. A more detailed discussion of the concept option scoring, and portfolio evaluation results can be found in Chapter 6 of this Summary Report. Table 7.14 summarizes the concept options, priority, and the associated costs per WRP.

Table 7.14 Summary of Concept Option Portfolios Summary Report One Water LA 2040 Plan					
WRP	Priority	#	Concept Option Name	Total Long Term Concept Option Cost Estimate (\$M)	WWFP Portion of Cost (\$M)
HWRP	A	13	MBR at HWRP to Regional System	\$900	\$900
	B	18	Hyperion to LADWP Distribution System	\$2,800	\$2,500
	C-1	11	HWRP to Central Basin Injection Wells	\$3,300	\$1,700
	C-2	10	HWRP to West Coast Basin Injection Wells	\$900	\$450
DCTWRP	A	15	DCTWRP to LA Aqueduct Filtration Plant	\$310	\$220
	A	22	East-West Valley Interceptor Sewer	\$85	\$85
	B	16	DCTWRP to LADWP Distribution System	\$295	\$260
	C	9	DCTWRP to San Fernando Basin Injection Wells	\$360	\$200
LAGWRP	A	17	LAGWRP to Headworks Reservoir	\$140	\$120
	B	23	Increase Recycled Water Demand beyond 2015 UWMP	\$70	\$0

As noted in the discussion of the concept options, the implementation may require upgrades to the WRP and the surrounding system. Only the WRP portion of the cost was carried forward into the WWFP Adaptive CIP.

7.8.6 Estimated and Projected CIP Summary

Information from the WCIP is collated and presented by facility (each of the WRPs and the collection system), phase (near-term, mid-term and long-term), and category (replacement and rehabilitation, climate resiliency and capital project). After the compilation of the Estimated CIP, the distribution of costs was reviewed. In areas where no or low estimates were available, costs were projected utilizing the methods summarized in Chapter 11 (see Volume 2). As the City defines more projects, the Projected CIP should be updated to reflect the most current numbers for the near, mid, and long terms. Projects for each CIP are summarized in Appendix H of Volume 2.

7.8.7 WWFP Adaptive CIP

The combination of the In-Progress Projects, Estimated and Projected CIP, future concept options and current integration opportunity form the basis for the WWFP Adaptive CIP. The Adaptive CIP is summarized in 2017 dollars in Table 7.15.

Table 7.15 WWFP Adaptive CIP Summary 2017 (\$M)					
Summary Report					
One Water LA 2040 Plan					
Category	Near-term (2018- 2020) (\$M)	Mid-term (2021- 2030) (\$M)	Long-term (2031- 2040) (\$M)	Total (\$M)	
In Progress Projects					
Advanced Treated Recycled Water Delivery to LAX and Scattergood Generating Station	\$38 ⁽¹⁾	\$92		\$130	
HWRP Delivery Expansion to 70 mgd for WBMWD and LA Harbor Area	\$16 ⁽²⁾			\$16	
Groundwater Replenishment Project with AWPf at DCTWRP	\$185	\$185		\$370	
LAGWRP Increase Recycle Water Demand per 2015 UWMP	\$73			\$73	
TIWRP AWPf Expansion to 12 mgd	n/a ⁽³⁾			n/a ⁽³⁾	
Subtotal	\$311	\$277	\$0	\$589	
Current Integration Opportunities					
Rancho Park WRF	\$58 ⁽⁴⁾			\$58	
Subtotal	\$58			\$58	
Water Reclamation Plants					
Capital Project from WCIP	\$178	\$71	\$10	\$259	
Replacement & Rehabilitation from WCIP	\$184	\$115	\$12	\$311	
Climate Resiliency Project	\$27		\$14	\$41	
Projected Capital Project		\$59	\$1,360	\$1,419	
Projected Replacement & Rehabilitation Project		\$100	\$518	\$618	
Subtotal	\$389	\$345	\$1,914	\$2,648	
Collection System					
Collection System	\$641	\$78	\$22	\$741	
Subtotal	\$641	\$78	\$22	\$741	
Future Integration Opportunities (WWFP Cost Element)					
Concept Option #13 (MBR at HWRP to Regional System)			\$900	\$900	
Concept Option #15 (DCTWRP to LA Aqueduct Filtration Plant)			\$220	\$220	
Concept Option #17 (LAGWRP to Headworks Reservoir)			\$120	\$120	
Concept Option #22 (East-West Valley Interceptor Sewer)	\$85			\$85	
Subtotal	\$85	\$0	\$1,240	\$1,325	
Total	\$1,484	\$700	\$3,176	\$5,360	
Notes:					
(1) Cost of phase 1 of this project is estimated at \$38 million, scheduled to occur in the near-term. Expansion of additional 3.5 mgd (product water) could occur in the mid-term, for an estimated capital cost of \$92 million for a total capital cost of \$130 million. For conservative cost estimations, the expansion was included in the CIP.					
(2) An additional cost of \$400 million could be incurred in the future should 70 mgd of MBR treatment be installed at HWRP.					
(3) TIWRP Expansion to 12 mgd was completed during the finalization of the WWFP. For this reason, it has not been included in the total cost of the In-Progress Projects.					
(4) Rancho Park WRF project costs are currently being refined.					

As shown on Figure 7.24, the Adaptive CIP for the near-term totals, \$1,484 million, the mid-term totals \$700 million and the long-term totals \$3,176 million. This is driven by both the future integration opportunities as well as the projected capital and replacement and rehabilitation project estimates.

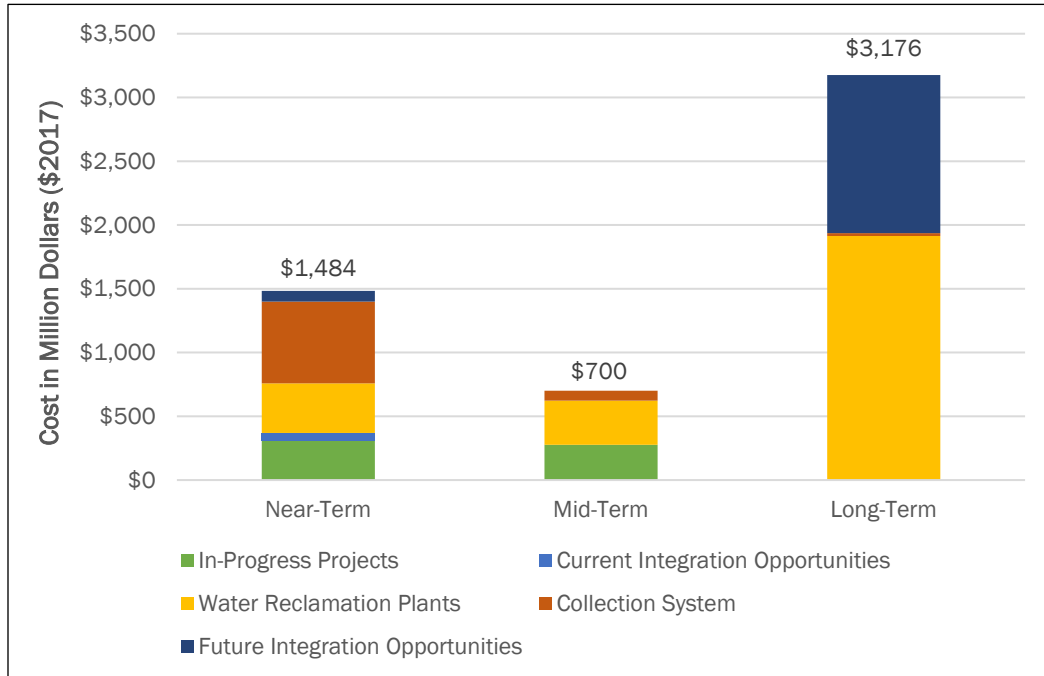

Figure 7.24 WWFP Adaptive CIP Summary by Phase

Figure 7.25 shows the largest portion of the total WWFP Adaptive CIP is to be spent on the WRPs. The cost distribution of projects by water reclamation plant is provided in Chapter 9 and Volume 2.

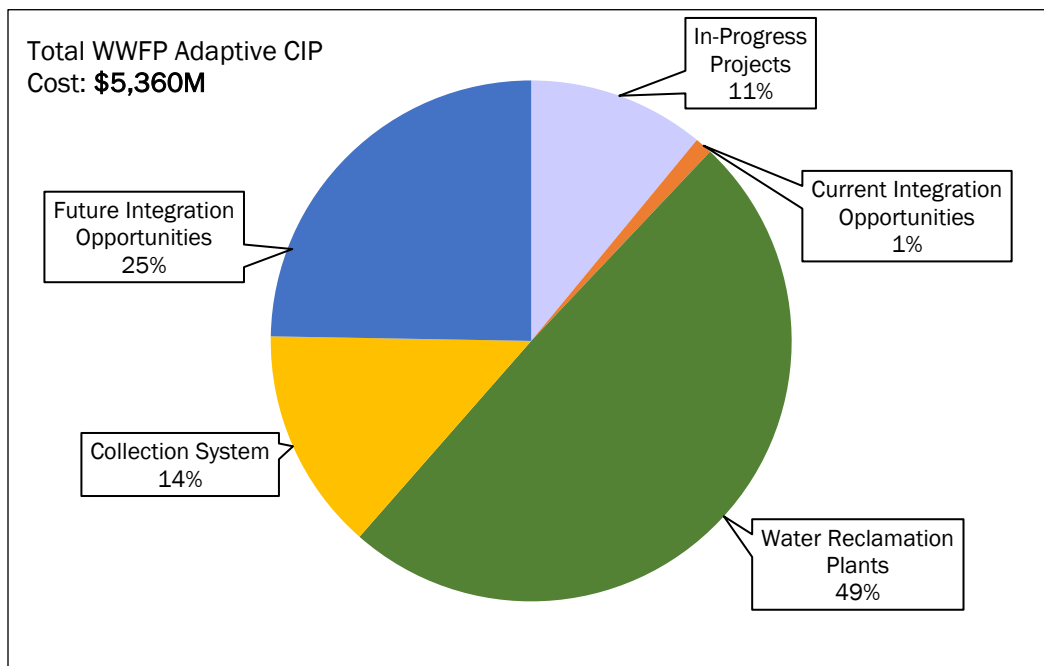

Figure 7.25 WWFP Adaptive CIP by Category

7.8.8 Escalated CIP

This section provides the methodology and budgetary figures for an “escalated” Adaptive CIP. Estimates of costs are presented for the wastewater facilities categories previously discussed:

- In-Progress Projects
- Current integration opportunities
- Future integration opportunities (concept options)
- Estimated and Projected CIP

The expenditures for each of these project categories were developed in 2017 dollars. Recognizing that the City will not implement all projects identified at once, costs for the near-term, mid-term and long-term projects were adjusted to account for inflation, escalated at a rate of 3 percent per year.

To compare costs between different implementation phases, the project costs were then brought back to a present value using a discount rate of 2 percent per year. Discounting the escalated costs yields a net present value and reflects the future escalated values in today's 2017 dollars. These escalation and discount factors were determined based on industry standards and are consistent with other One Water LA documents.

Figure 7.26 shows the total Adaptive CIP is \$6,062 million over a 20 plus year timeframe. The near-term planning phase shows a total of \$1,519 million or \$506 million per year. The mid-term planning phase shows a total of \$757 million or \$75.7 million per year. The long-term planning phase shows a total of \$3,786 million or \$378.6 million per year.

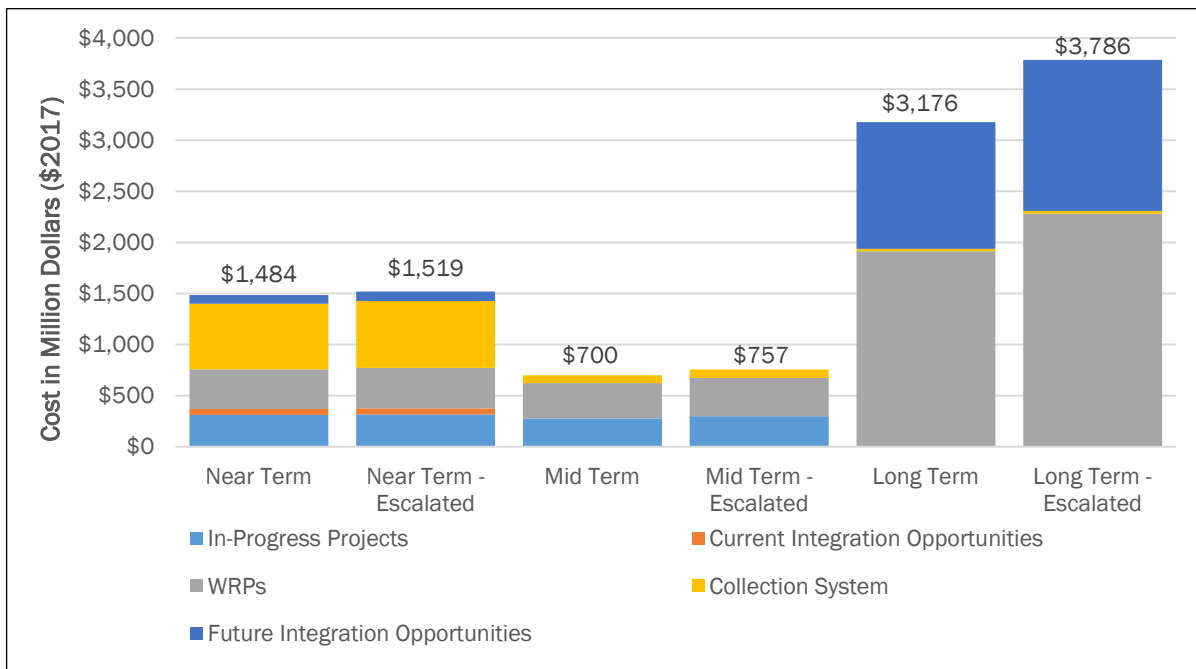

Figure 7.26 CIP Comparison of Net Present Values

The projected annual rate of CIP costs is the highest for the long-term. The mid-term presents the lowest rate of annual expenditures, with the near-term projected between the mid and long-term annual projected expenditures.

Figure 7.27 shows a proposed timeline for this WWFP Adaptive CIP. The durations are estimated based on the CIP and the development of the In-Progress Projects and concept options. The figure provides a better indication when certain costs would be incurred by the City for the CIP projects.

Overall, the most significant expenditures are for projects that would be implemented within the next three years and on work which is planned for execution in the long-term. The near-term work has already been scoped by the City and is the best defined of all the projects. The long-term work is primarily focused on the Priority A concept options which require specific triggers for these projects to proceed. The long-term expenditures also contain projects with the largest costs and impacts to the City's total wastewater system.

In order to implement the Mayor's water reuse goals it will be necessary for LASAN to take an active role in pursuing the specific triggers for the preferred portfolio options and begin planning for work that will start in the future.

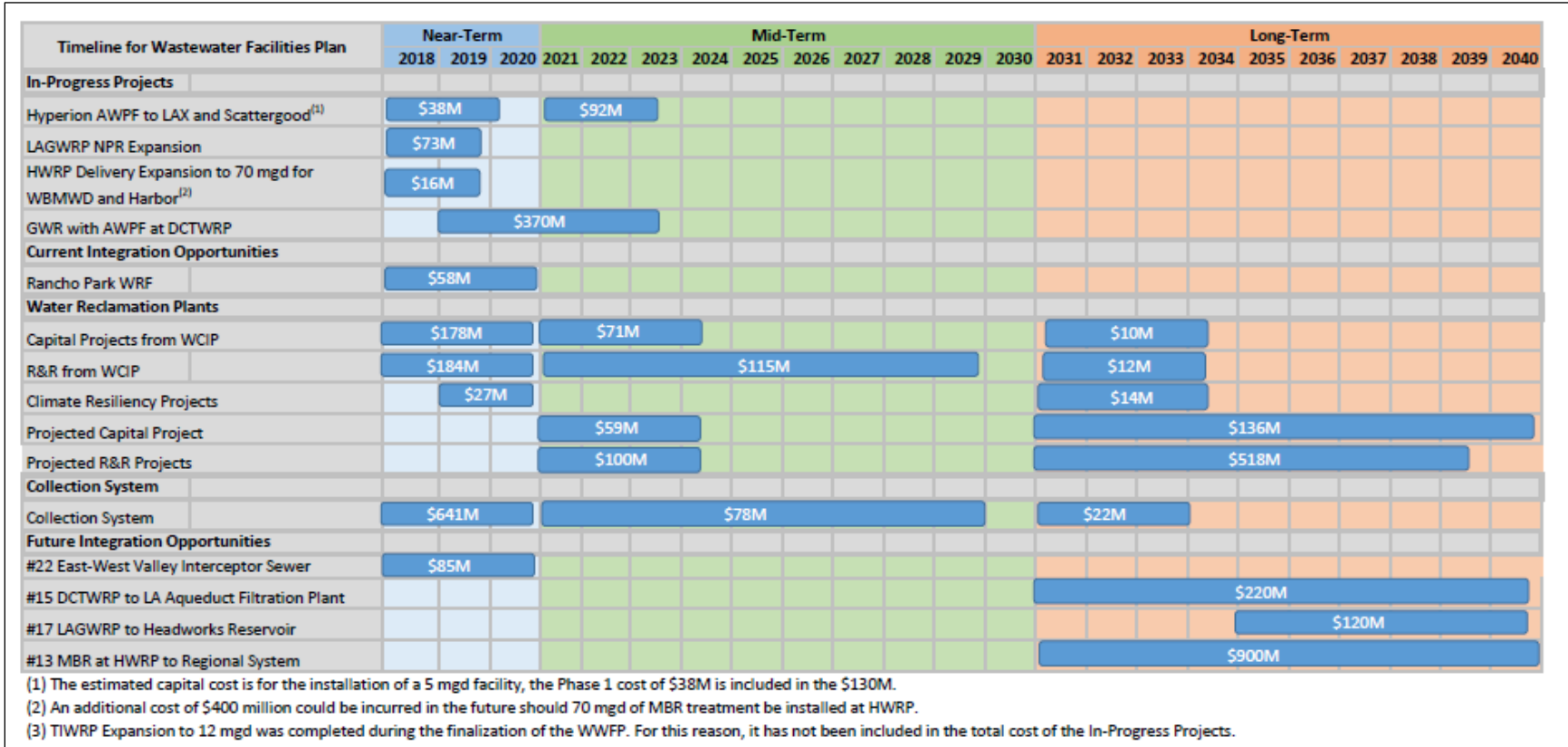

Figure 7.27 Timeline for Wastewater Facilities Plan

STORMWATER AND URBAN RUNOFF FACILITIES PLAN

Chapter 8 provides a summary of the Stormwater and Urban Runoff Facilities Plan (SWFP), which is included in Volume 3 of the One Water LA 2040 Plan (Plan). The SWFP describes the City of Los Angeles' (City) existing stormwater infrastructure and relevant policies, plans, and programs, as well as the recommendations for the integration of stormwater infrastructure facility management in the City by 2040. Both existing system and future system improvements are combined in a comprehensive Stormwater Improvement Program (SIP), which is documented in detail in the SWFP and summarized at the end of the Chapter.

This Chapter first describes the purpose of the SWFP and the basis of planning. Subsequently, the existing stormwater infrastructure is discussed, followed by a methodology for identifying and selecting stormwater infrastructure projects, and the prioritized stormwater improvement program to guide the City with implementation of the large number of stormwater projects to meet compliance deadlines, mitigate flood risks, and achieve water supply benefits.

8.1 INTRODUCTION

Stormwater and urban runoff infrastructure is the set of infrastructure needed to convey or collect wet weather and dry weather runoff into, within, and throughout the City, collectively working to manage the risks of floods, meet water quality requirements, and provide local water supply. As the City seeks to expand its stormwater infrastructure network that was initiated in 1915, they are leading the way as one of the most proactive cities in the nation with regards to stormwater quality protection and enhancement.

Building on significant previous and currently existing stormwater infrastructure planning efforts, the SWFP evaluates various types of studies, plans, projects, and programs seeking to integrate efforts using a "Three-Legged-Stool" approach integrating water quality, water supply, and flood risk mitigation. As illustrated on Figure 8.1, the stormwater component of the One Water LA 2040 Plan comprehensively considers the following:

- **Water Quality Improvement** – These projects improve the health of local watersheds by reducing impervious cover, restoring ecosystems, decreasing pollutants in the waterways, and providing environmental and habitat benefits. Stormwater improvement projects intended to improve the quality of a downstream waterbody are typically driven by regulations such as TMDLs and/or 303(d) listings.
- **Water Supply Augmentation** – These projects capture runoff to help offset potable water use through direct use projects. They also increase water supply through groundwater augmentation and capture and use wet-weather/dry-weather runoff to offset potable water demand and/or enhance environmental and habitat conditions.
- **Flood Risk Mitigation** – These projects protect life and safety and mitigate local flood impacts. Stormwater improvement projects intended to reduce flood risks are typically driven by asset-specific needs, such as whether an asset is located near a known or anticipated area of flooding; insufficient capacity; asset deterioration or expiration of useful life based on age; and known or anticipated impacts from sea level or groundwater rise.

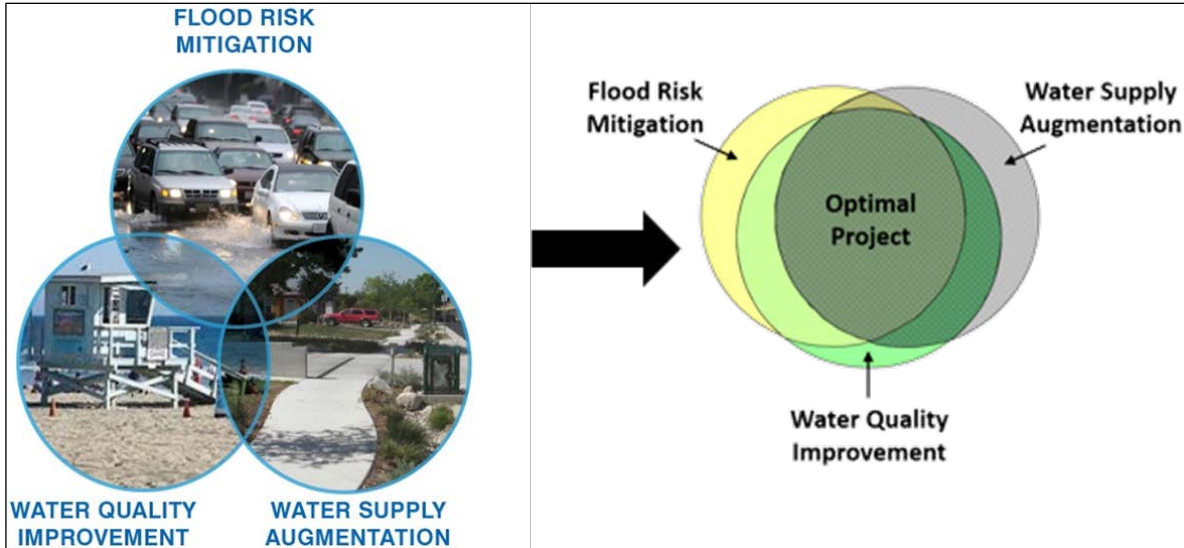

Figure 8.1 Illustration of the "Three-Legged Stool" Stormwater Planning

By integrating these efforts, the City's stormwater infrastructure needs, and requirements over the next 25 years are selected and includes the SIP that selects future infrastructure projects based on a variety of benefits achieved for the City.

The objectives of the SWFP are to:

1. Review and summarize the City's stormwater infrastructure and relevant policies, plans, and programs – past, present, and future;
2. Integrate various aspects of stormwater components and find implementation opportunities that assist with flood protection, water quality benefits, and/or water supply benefits and enhancements with all City departments and regional entities;
3. Provide a methodology for identifying and selecting stormwater infrastructure projects. Among numerous other factors, this methodology will consider results from the Climate Risk and Resilience Assessment for Wastewater and Stormwater Infrastructure (One Water TM No. 5.5; see Volume 6), which identified stormwater infrastructure at risk of failure or loss of efficiency due to anticipated climate change scenarios and proposed corresponding climate resiliency infrastructure projects;
4. Make recommendations for the integration of stormwater infrastructure facility management in the City by 2040 by building on existing plans and studies, developing integrated management processes for decision making and selection of projects, and leveraging resources;
5. Develop a prioritized SIP to guide the City with the implementation of the large number of stormwater projects to meet total maximum daily load (TMDL) compliance deadlines, mitigate flood risks, and achieve water supply benefits; and
6. Help achieve the Mayor's stormwater capture goal of 150,000 acre-feet per year (AFY) by 2035 as defined in the Sustainable City pLAN.

In addition to an Executive Summary, the SWFP is divided into nine Chapters and contains nine appendices. The Chapters of the SWFP are as follows:

Chapter 1 – Introduction

Chapter 2 – Regulatory Background

Chapter 3 – Stormwater and Dry Weather Runoff Flows

Chapter 4 – Existing Stormwater System

Chapter 5 – Operations and Maintenance

Chapter 6 – Integrated Stormwater Management Analysis

Chapter 7 – Stormwater Improvement Program

Chapter 8 – Financial Strategy

Chapter 9 – Conclusions and Recommendations

8.2 REGULATORY BACKGROUND

Stormwater and urban runoff within the City are subject to a myriad of regulations, directives, and policies. Federal and State agencies set water quality goals and targets for runoff discharges in an effort to protect receiving waters, while also setting goals and targets for the use of runoff to benefit local water supply. In response, the City has developed master plans, ordinances, directives, and other documents to implement these goals and targets at the local level.

Chapter 2 of the SWFP summarizes the Federal, State, and local regulations and guidelines related to water quality, water supply, and flood mitigation that are applicable to the City. These regulations and guidelines, along with various regional planning efforts, are foundational to the development of the City's long term stormwater management strategy.

8.2.1 Water Quality Regulations

Among other regulations and guidance focusing on water quality improvement, the City was one of the first in the nation to develop green streets standard plans and to initiate and incorporate low impact development (LID) requirements into new development and redevelopment projects. In parallel with the development of the City's LID program, the City passed the Proposition O – Clean Water Bond in October 2004, authorizing \$500 million of general obligation bonds for projects to prevent and remove pollutants from regional waterways and the ocean, consequently protecting public safety while meeting federal Clean Water Act (CWA) regulations. More recently, the City completed a Stormwater Capture Master Plan (SCMP), five Enhanced Watershed Management Programs (EWMP), and one Watershed Management Program (WMP), which included detailed water quality modeling for all City watersheds to demonstrate reasonable assurance of compliance with applicable water quality standards within the region. In addition, the Public Right-of-Way Green Stormwater Infrastructure (PROW GSI) Program is slotted to be a groundbreaking "Green Streets" policy. With streamlined implementation procedures and emphasis on areas of greatest environmental need, it may be the first of its kind on the West Coast, if not nationwide.

8.2.2 City of LA Water Supply Directives

In addition to the LA Green Building Code, which includes both mandatory and voluntary measures relative to local water supply, two executive directives from the Mayor were issued that directly affect water supply:

- Executive Directive Number 5, which seeks to reduce potable water use and imported potable water demand, and created an integrated strategy to increase local water supply; and
- Executive Directive Number 7, which directed City departments to implement the goals of the Sustainable City pLAn.

8.2.3 Flood Risk Management

The City is generally responsible for the mitigation efforts of flood events with a 10-year or less return period (Los Angeles Bureau of Engineering [LABOE], 1986). Regional, state, and federal agencies, including U.S. Army Corps of Engineers (USACE) and Los Angeles County Flood Control District (LACFCD), design stormwater facilities for a much larger range of flood events, generally ranging from the 10-year flood event to the 100-year flood event.¹

Los Angeles Department of Public Works (LADPW), LACFCD, and the USACE all share responsibility in managing local flood risks in the City. Inter-agency cooperation is assumed based on existing and future requirements, regulations, and Memorandums of Understanding (MOU) with respect to financing, constructing, and operating and maintaining flood control projects described herein.

Given the rapidly evolving nature of stormwater management within the City, stormwater and dry weather runoff flows are expected to change significantly over the next 25 years, thereby influencing and affecting infrastructure needs in this timeframe. The SWFP relies on previous hydrologic modeling results to provide the context for existing demands being placed on the City's storm drain system.

¹ For example, LACFCD's Hydraulic Design Manual (LACFCD, 1982) sets a minimum design storm frequency of 10-years for applicable drains, and the USACE's Los Angeles River Ecosystem Restoration Feasibility Study (USACE, 2015), commonly known as the ARBOR Study, shows that portions of the LA River have capacity above the 100-year flow rate.

8.3 STORMWATER AND DRY WEATHER RUNOFF FLOW DEFINITIONS

For the purpose of the SWFP, the stormwater and dry weather runoff are defined as coming from five main sources:

- **Precipitation:** Precipitation which falls over the City;
- **Upstream Run On:** Flows that enter the City from tributary watersheds;
- **Groundwater Upwelling:** Groundwater that seeps into the Municipal Separate Storm Sewer System (MS4) or surface waterbodies due to rising groundwater levels;
- **WRP Discharges:** Discharge from a WRP to the MS4.
- **Irrigation and Incidental Flow:** Irrigation applied within the City and other incidental flow. Although these flows are most often associated with dry weather flows, they are also considered for stormwater runoff since they influence soil moisture, basin storage volumes, recharge volumes, and evapotranspiration.

Combining the efforts from the three major agencies that operate and maintain the stormwater infrastructure system, including both green and grey infrastructure, outflows are defined in the following way:

- **Discharge to Streams/Rivers/Channels:** Runoff that reaches streams, rivers, or channels. Some of this water is infiltrated, evapotranspired, or diverted.
- **Discharge to the Ocean:** Runoff that reaches the ocean.
- **Water Supply & Quality Benefits (Capture and Use/Potable Water Offsets):** Runoff that is captured and stored for use on-site, most often after being diverted from the MS4, which includes streets, drains, and other conveyances.
- **Water Supply & Quality Benefits (Environmental and Habitat):** Runoff that passively infiltrates into the ground through permeable surfaces, such as green infrastructure. These are in areas of the City where there is no groundwater aquifer connectivity for the City or other regional pumpers to directly benefit from this water for water supply.
- **Water Supply & Quality Benefits (Groundwater Recharge/Direct Water Supply):** Runoff that is infiltrated into the City's groundwater aquifers via mid-size regional or large regional projects, such as drywells, infiltration basins, or spreading basins.
- **Evapotranspiration:** Runoff that is consumptively used by plants or evaporated directly.

8.3.1 Watershed Management Area Overview

In Los Angeles Department of Water and Power (LADWP)'s recently completed SCMP, the areas tributary to the City were divided into 17 subwatersheds (15 of which contain City area). A hydrologic model was completed that simulates stormwater inflow and outflow according to the subwatershed as defined by the SCMP. For the purposes of the One Water LA 2040 Plan, the SCMP subwatersheds and the corresponding hydrological model outputs were combined to match the four Watershed Management Areas (WMA) adopted from the recently completed EWMPs, which are:

- Ballona Creek (BC)
- Dominquez Channel (DC)
- Santa Monica Bay (SMB), including Marina del Rey (MdR), Santa Monica Bay Jurisdictions 2 and 3 (J2/3), and Santa Monica Bay Jurisdiction 7 (J7) subwatersheds.
- Upper Los Angeles River (ULAR)

Figure 8.2 shows the four WMAs along with the SCMP subwatersheds. Based on the model runs completed for the SCMP, the WMP/EWMPs, and a cross check of project metrics, the existing distribution of average annual flows in the City were analyzed based on historical rainfall records and existing development conditions.

8.3.2 Estimated Stormwater Flows

A summary of the hydrologic model results by WMP/EWMP watershed are shown in Table 8.1. For the modeled existing condition, approximately 764 million gallons (MG) of total inflow to the City is estimated to occur per day, on average. Of this inflow, approximately 380 MG of runoff is estimated to make its way to receiving water channels and streams. After accounting for losses and diversions from these streams and channels, approximately 353 MG (46 percent of the total inflow) is estimated to discharge from the storm drain system into the ocean. 353 MG (46 percent of the total inflow) is either evaporated from the City or is infiltrated into unusable aquifers, and approximately 58 MG (8 percent of the total inflow) is infiltrated through permeable areas or in centralized spreading grounds.

The stormwater flow estimates presented below reflect existing conditions and are based on model runs completed for the SCMP, the WMP/EWMPs, and a cross check of project metrics. As shown, it is estimated that approximately 92,000 AFY of stormwater is captured for direct use, environmental and habitat supply, and groundwater recharge. The Sustainable City pLAn has set a goal to increase this to 150,000 AFY by year 2035. Hence, this equates to an increase of 58,000 AFY (63 percent) compared to current conditions. The recommended SIP presented in the SWFP (Volume 3) as well as the long-term integration opportunities presented in Chapter 6 of this report are intended to collectively achieve this goal.

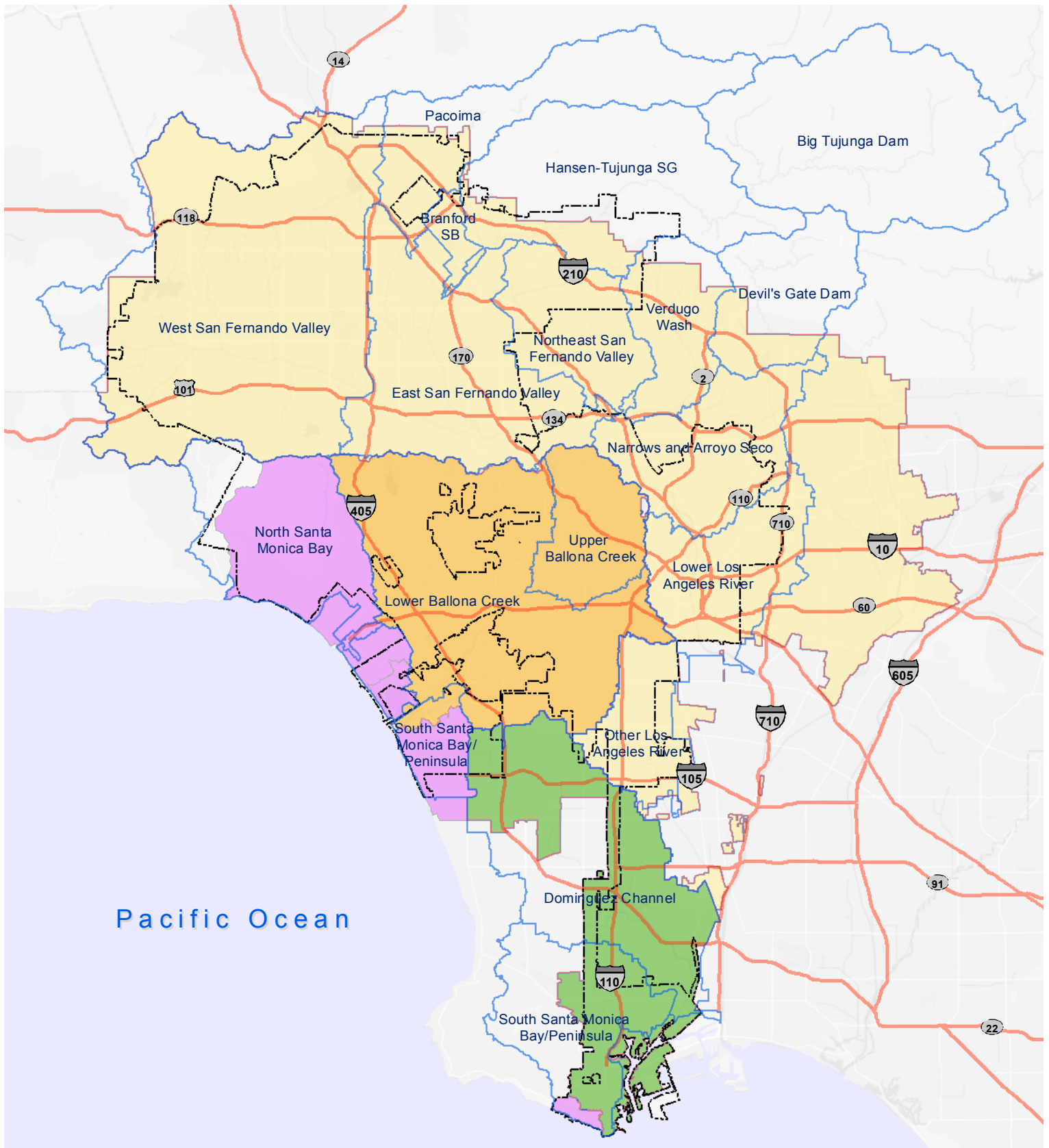

Legend

- City of LA Boundary
- SCMP Subwatershed Boundary
- Major Highway
- WMA Boundary**
- Ballona Creek
- Dominguez Channel
- Santa Monica Bay
- Upper Los Angeles River

Figure 8.2
WMA Boundaries and SCMP Subwatersheds
within the City of LA

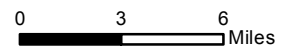

Watershed Area		Ballona Creek		Dominguez Channel		Santa Monica Bay ⁽²⁾		Upper Los Angeles River		City Total		
Average Daily and Annual Flows		(mgd)	(AFY)	(mgd)	(AFY)	(mgd)	(AFY)	(mgd)	(AFY)	(mgd)	(AFY)	
Inflow	Precipitation	84	94,100	12	13,400	36	40,300	234	262,100	366	409,900	
	Runoff from Upstream of City	10	11,200	20	22,400	3	3,400	102	114,300	135	151,300	
	Irrigation	43	48,200	8	9,000	13	14,600	156	174,700	220	246,500	
	WRP Discharge ⁽³⁾	0	0	0	0	0	0	39	43,700	39	43,700	
	Groundwater Upwelling	0	0	0	0	0	0	4	4,500	4	4,500	
	Total Inflow	137	153,500	40	44,800	52	58,300	535	599,300	764	855,900	
Outflows	Discharge	To Streams/ Rivers/Channels	59	66,100	29	32,500	16	17,900	276	309,200	380	425,700
		To Ocean ⁽¹⁾	59	66,100	27	30,200	17	18,900	250	279,900	353	395,100
	Water Supply & Quality Benefits	Capture & Use	0	0	0	0	0	100	0	100	0	200
		Environmental & Habitat	8	9,000	2	2,300	4	4,600	10	11,300	24	27,200
		Groundwater Recharge	3	3,400	0	0	0	0	55	61,600	58	65,000
		Evapotranspiration	67	75,000	11	12,300	31	34,700	220	246,400	329	368,400
	Total Outflow	137	153,500	40	44,800	52	58,300	535	599,300	764	855,900	
Notes:												
(1) Discharge to ocean does not include discharge diverted from channels, rivers, or streams. The total outflow is computed based on discharge to streams and channels only.												
(2) Although a separate watershed management effort was completed for SMB J2/3, SMB J7, and MdR, these three watersheds have been merged together as "Santa Monica Bay Watershed Management Area" for this Facility Plan.												
(3) Discharges from the Hyperion and Terminal Island WRPs were not included since these two WRPs directly discharge into the ocean.												
Abbreviations:												
mgd = million gallons per day; AFY = acre-feet per year; WRP = water reclamation plant												

Over the next 25 years, additional distributed, regional, and centralized infiltration Best Management Practices (BMPs) will be implemented in areas conducive to recharge, provided funding is available. In addition, other infiltration BMPs, along with capture and use BMPs, will be implemented in areas where recharge is not conducive, which will reduce runoff and potable water demand and provide water resource benefits other than groundwater recharge. Although the direct impacts of such efforts have yet to be quantified in terms of stormwater flow rates within the MS4 network, the City estimated an average annual capture volume of 29,000 MG of stormwater for the average storm year based on the implementation of all EWMP-defined BMPs.

8.3.3 Historical Dry Weather Runoff

Due to the significant spatial variation in the quantity of dry weather runoff throughout the City, high-resolution modeling efforts have not been undertaken to quantify such flows. Rather, where available, historical monitoring records are relied upon to understand urban runoff flows within the City's MS4. Dry weather flows within the City include incidental urban runoff, WRP discharges, and groundwater upwelling.

Throughout the City, low flow diversions (LFD) have been installed to divert runoff flows from the storm drain for treatment or storage. In most cases, all dry weather flows within the storm drain upstream of a LFD are diverted to the sanitary sewer and conveyed to a WRP for treatment. LFDs can also operate during wet weather events to improve water quality during storm events by capturing a portion of stormwater runoff for treatment to the WRPs. To-date, LASAN owns and operates 21 LFDs. In average, LASAN-owned LFDs divert approximately 1,500 AFY of dry weather runoff to the HWRP.

An additional 42 LFDs have been identified as part of this Plan to increase capture of dry weather runoff in strategic locations. It is estimated that the addition of these LFDs can increase dry weather diversion by 6,000 AFY. Supporting analysis can be found in Chapter 3 (Volume 3).

8.4 EXISTING STORMWATER SYSTEM

The stormwater infrastructure network within the City is a complex system of streets, catch basins, pipes, channels, basins, pump stations, and other infrastructure that work collectively to manage stormwater and urban runoff. It can be generally grouped into grey and green infrastructure, where grey infrastructure is defined as the conveyances historically developed to provide flood protection, and green infrastructure are composed of the "nature-inspired" and mechanical systems developed to mimic natural processes.

8.4.1 Key Players: Roles and Responsibilities

LADPW, LACFCD, and USACE are three primary agencies that have historically been responsible for the design, construction, and maintenance of the City's stormwater infrastructure. In addition, there are over twenty City, County, State, and Federal agencies that, since the 1990s or later, have been incorporating green stormwater infrastructure projects, Capital Improvement Plans (CIPs), and management decisions into their activities to help the City comply with stormwater regulations. A select list of key agencies within the City that are involved with stormwater planning is summarized alphabetically by governance level in Table 8.2. It can be concluded that stormwater planning involves a large number of agencies, requiring extensive coordination and collaboration.

Table 8.2 Select List of Key Agencies Summary Report One Water LA 2040 Plan					
City of LA Departments		LA County	State	Federal	Other
LADPW	Transportation	Public Works	Caltrans	USACE	Metropolitan Water District of Southern California
LADWP	General Services	LACFCD	High Speed Rail Authority	Federal Emergency Management Agency	Water Replenishment District of Southern California
Recreation and Parks	LA World Airports	Parks and Recreation	Parks and Recreation		Private Owners
City Planning	Port of LA	Sanitation District			Developers
Building Safety	LA Zoo	Metro			
LA Unified School District	LARiverWorks				

8.4.2 Existing System Overview

The stormwater infrastructure system within the City works collectively to provide multiple benefits to the public at-large and includes both grey and green infrastructure. Table 8.3 provides a comprehensive summary of the City's existing grey infrastructure. Figures showing locations of grey infrastructure within the City are presented in Appendix C of the SWFP (see Volume 3).

Table 8.3 Identified Existing Grey Infrastructure in City of LA Summary Report One Water LA 2040 Plan							
Infrastructure Type	Infrastructure Ownership by O&M Agency						Total
	City of LA	LA County	Caltrans	USACE	Private Developer	Unknown	
Storm Drain Length (mi)	1,215	619	153	<1	21	284	2,605
Open Channel Length (mi)	57	123	3	20	1	27	269
No. of Lift Stations	11	5	0	0	0	0	16
No. of LFDs	14	28	0	0	0	0	42
No. of Debris Basins	85	138	0	0	0	0	223
No. of Dams	0	1 ⁽¹⁾	0	3 ⁽²⁾	0	0	4
Notes:							
(1) Pacoima Dam							
(2) Lopez Dam, Hansen Dam, Sepulveda Dam							
Abbreviation:							
mi = miles							

As summarized in Table 8.3, there are approximately 2,500 miles of stormwater conveyance network identified in the City.² Of the identified stormwater conveyance network, 87 percent is currently operated and maintained by one of the four public agencies.

When it comes to green infrastructure, both regional and distributed projects are needed to maximize the water quality, water supply, and flood risk management benefits the City desires to achieve with its stormwater management system. The City cannot address its stormwater management needs with regional or distributed projects alone. Figures showing locations of green infrastructure within the City are presented in Appendix D of the SWFP (see Volume 3).

8.5 OPERATIONS AND MAINTENANCE

Operation and Maintenance (O&M) requirements and corresponding resource allocations must be considered during the project planning phase through design, construction, and optimization. Proper planning and executing O&M activities, from upstream pretreatment devices (e.g., trash/debris interceptor, sedimentation basin) through all other components of a project, can significantly improve the lifespan of a BMP facility, thereby increasing the project benefits at the project and watershed scale.

One common element shared among successful green and grey infrastructure projects is comprehensive O&M planning throughout the entire project life cycle. Key planning considerations are the project development phase, design phase, construction phase, and system performance phase. Operational requirements for green infrastructure are largely general and uniformly apply to all project categories, including ensured access, authorized access, safety, and documentation.

Grey infrastructure has a common knowledge approach to operations and maintenance, as these devices have been established longer than green infrastructure facilities and have a longer history of testing and data.

O&M is a critical component to ensure the proper performance of green and grey stormwater infrastructure over its designed service life. O&M requirements and corresponding resource allocations must be considered during the project planning phase through design, construction, and optimization. Neglect of O&M planning and insufficient resource allocation, such as budget, staff, equipment, and procedure training, could result in inadequate O&M activities, which could lead to shorter project life span, overall reduction in project life cycle benefits, and potential failure to achieve water quality compliance and water supply objectives. In light of this, future O&M challenges include an increased need for resources, an increased demand for monitoring data, and a need for an improved system to evaluate and assess project performance.

Additional details regarding general O&M of the City's stormwater facilities can be found in Chapter 5 of Volume 3.

² The stormwater conveyance network length is calculated from the storm drain geodatabase provide by LADPW and LACFCD. Both geodatabases are regularly updated.

8.6 INTEGRATED STORMWATER MANAGEMENT APPROACH

The "three-legged stool" approach to project benefit assessment and integration with respect to short and long-term project planning is developed within the SWFP. This integrated strategy aims at capturing "missed opportunities" in flood risk mitigation, water quality improvement, and water supply augmentation under existing conditions discussed herein, and hence would offer a comprehensive, well-rounded planning effort to meet the City's long-term stormwater management needs.

8.6.1 The Practical Project Manager – The Three-Legged Stool

Stormwater infrastructure projects are typically targeted to address either flood risk mitigation, water quality improvement, or water supply augmentation. It is the intent of this SWFP to incorporate all three benefits into the "three-legged stool" integrated approach to stormwater and urban runoff infrastructure planning. This will help guide the decision-making process through the new selection scheme.

8.6.2 Water Quality Improvement Projects

Stormwater improvement projects intended to improve the quality of a downstream waterbody are typically driven by regulations such as total maximum daily loads (TMDLs) and/or 303(d) listings. As required by the Los Angeles County MS4 Permit, the City prepared several EWMPs and one WMP to address impairments to downstream waterbodies such as rivers, bays, and oceans. The EWMPs³ specified both regional and distributed projects predicted to achieve the required pollutant load reduction(s) by the TMDL-specified deadlines. LASAN is currently in the process of planning, designing, and constructing those projects, cooperating with other local agencies where multiple parties are involved. Corresponding selection drivers have been developed to select water quality improvement projects based on applicable TMDL compliance deadlines (e.g., <5 years, 6 – 15 years, > 15 years). Figure 8.3 illustrates the flowchart to evaluate the water quality benefits of a stormwater improvement project within this SWFP.

³ No structural projects were proposed in the SMB J7 WMP.

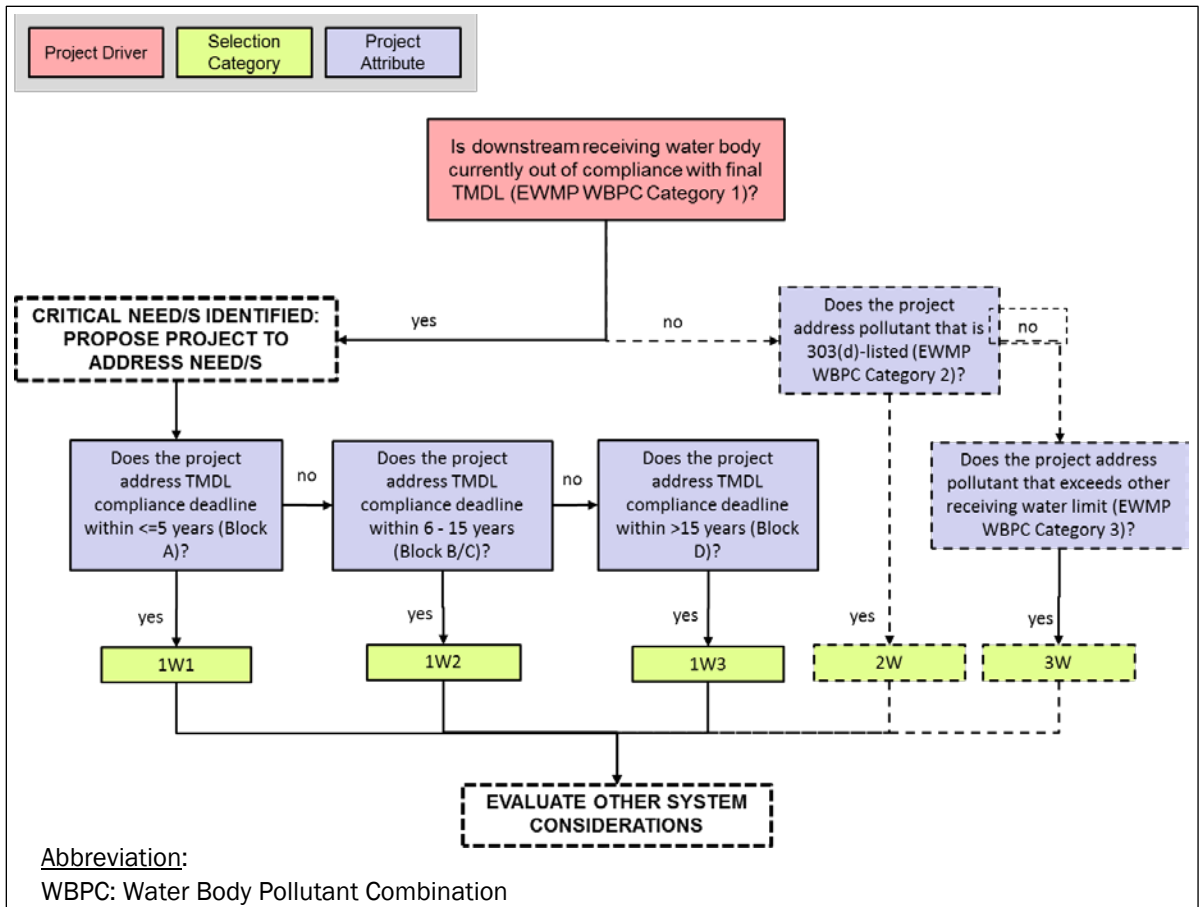

Figure 8.3 Water Quality System Considerations

8.6.3 Water Supply Improvement Projects

Stormwater improvement projects intended to enhance local water resources are typically driven by goals to reduce potable water demand. Potable water demand reduction can be achieved through conservation measures, augmentation of groundwater recharge, enhancement of local water supplies by promoting water reuse/recycling, and/or capture and use of wet weather/dry weather runoff to offset potable water demand. Specific attention is given to enhancing the ability of the City to provide local water during a drought. In general, projects targeting local water supply augmentation are developed to diversify the City's water supply portfolio, create a more locally controlled source of water supply, and, in some instances, to respond to known or anticipated water supply and reliability challenges. Large-scale water supply augmentation projects are typically expected to be initiated and led by LADWP or other partners; however, smaller-scale and distributed projects with infiltration components resulting in water supply benefits could be led by any agency or City department. Figure 8.4 illustrates the flowchart to evaluate the water supply benefits of a stormwater improvement project within this SWFP.

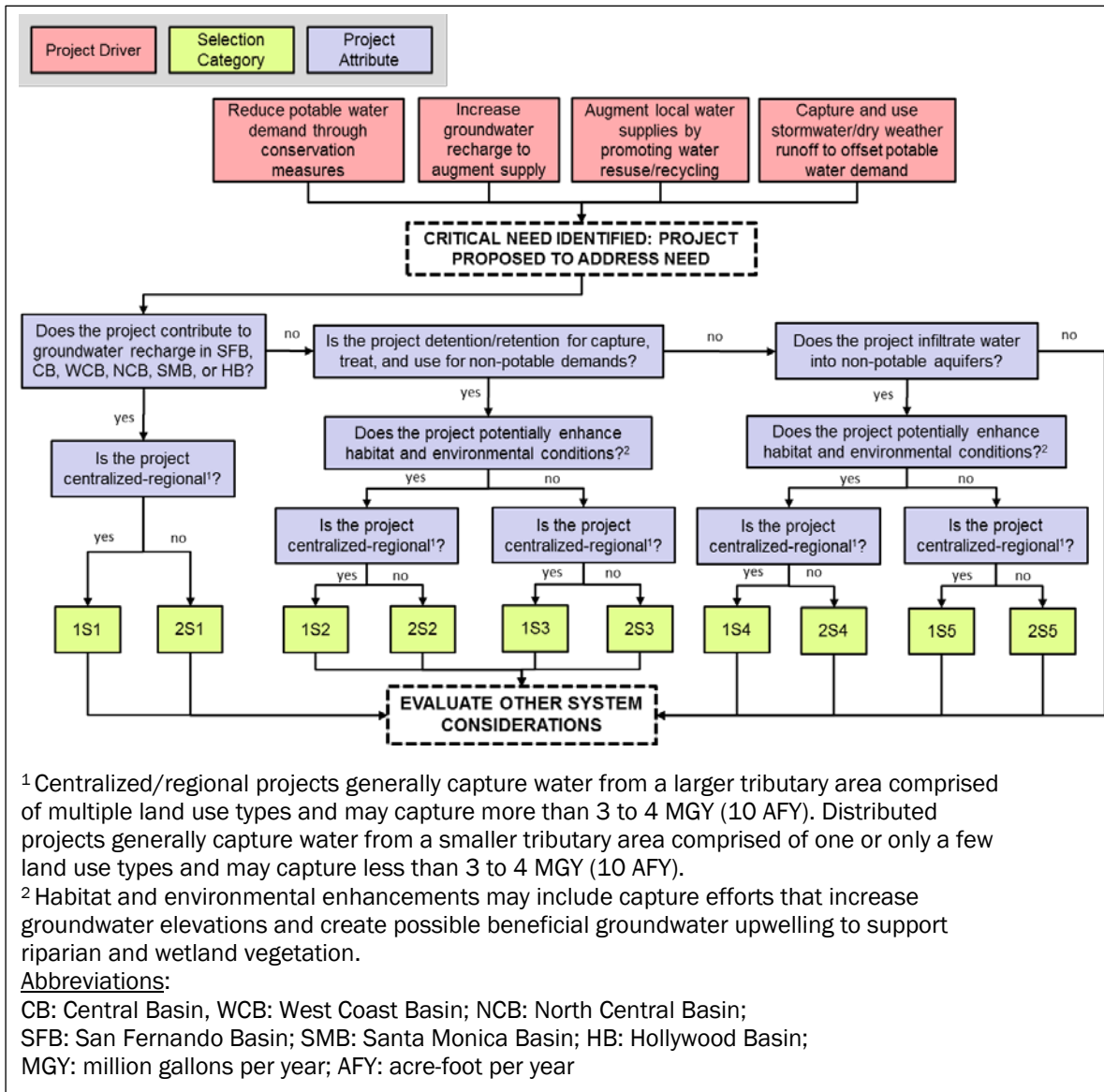

Figure 8.4 Water Supply System Considerations

8.6.4 Flood Risk Mitigation Projects

Stormwater improvement projects intended to reduce flood risks are typically driven by asset-specific needs, such as location with respect to a known or anticipated area of flooding; insufficient capacity; asset deterioration or expiration of useful life based on age; and/or known or anticipated impacts as a result of sea level or groundwater rise. Infrastructure projects or improvements designed to address flood risk management may be owned, operated, and/or maintained by multiple agencies such as LABOE, LACFCD, USACE, etc. The City is generally responsible for the mitigation efforts of flood events with a 10-year or less return period (LABOE, 1986). Regional, state, and federal

agencies, including USACE and LACFCD, design stormwater facilities for a much larger range of flood events, generally ranging from the 10-year flood event to the 100-year flood event.⁴

Figure 8.5 illustrates the flowchart to evaluate the flood risk benefits of a stormwater improvement project within this SWFP.

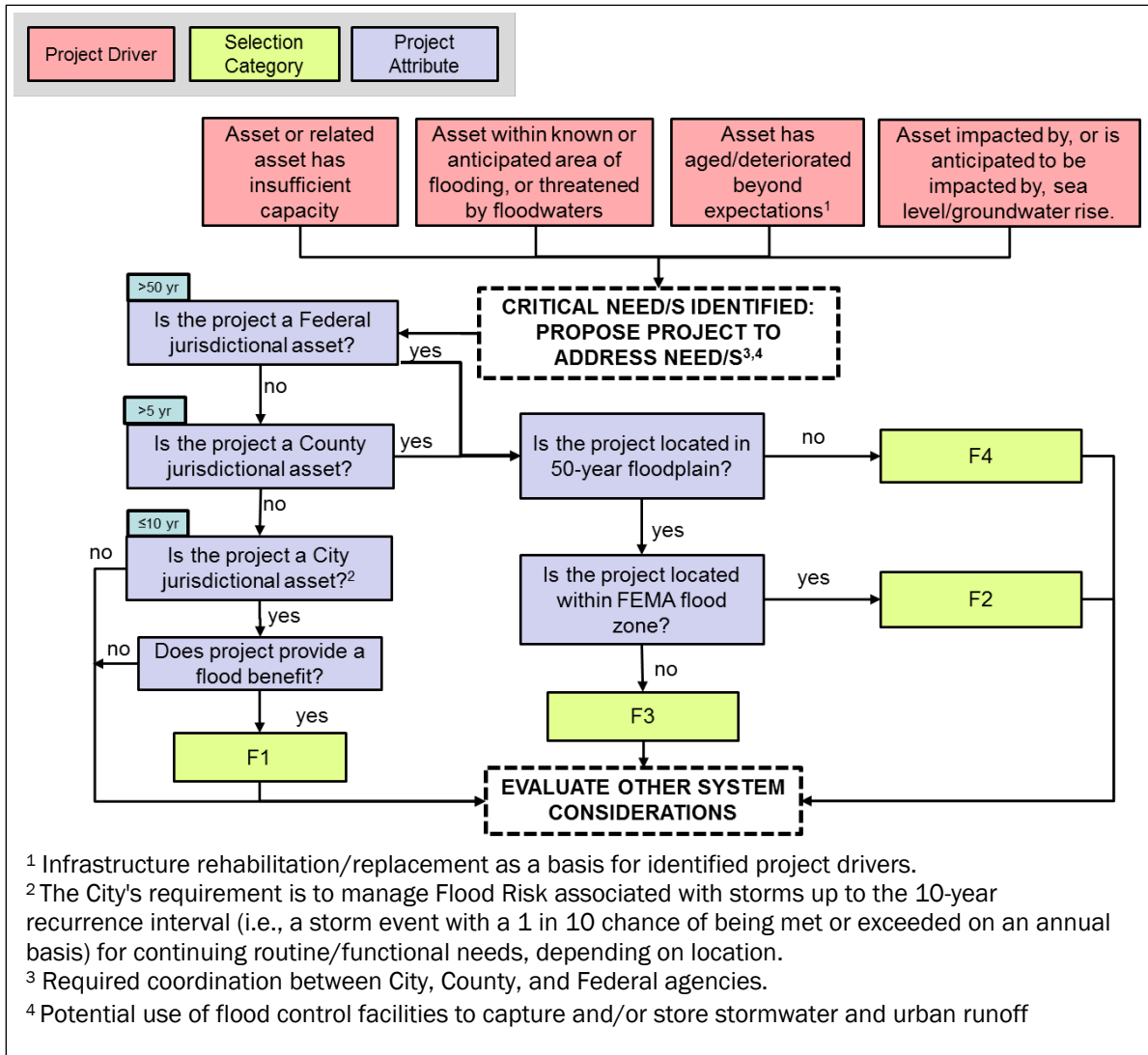

Figure 8.5 Flood Risk Management System Considerations

⁴ For example, LACFCD's Hydraulic Design Manual (LACFCD, 1982) sets a minimum design storm frequency of 10-years for applicable drains, and the USACE's Los Angeles River Ecosystem Restoration Feasibility Study (USACE, 2015), commonly known as the ARBOR Study, shows that portions of the LA River have capacity above the 100-year flow rate.

8.6.5 Multi-Benefit Stormwater Projects

Ideally, flood risk improvements, water quality benefits, and water supply augmentation are inherent to all projects. It is the intent of this SWFP to attempt to select projects that result in benefits in all three areas. The implementation of an integrated approach to stormwater management is expected to result in lower costs over the long-term due to the following reasons: 1) the cost of one multiple-benefit project is anticipated to be less than the cost of multiple single-benefit projects that achieve the same goals; and 2) fewer projects may be necessary to meet local goals, leading to long-term savings.

In addition to the primary benefits discussed above, projects may also have secondary benefits, of particular value to the communities in which the projects are constructed. These secondary benefits can generally be grouped into environmental benefits and community benefits. Such secondary benefits may help address environmental or social equity targets, such as those included in the City of LA's Sustainable City pLAN. Figure 8.6 illustrates the flowchart to evaluate the integrated water resources benefit of a stormwater improvement project within this SWFP.

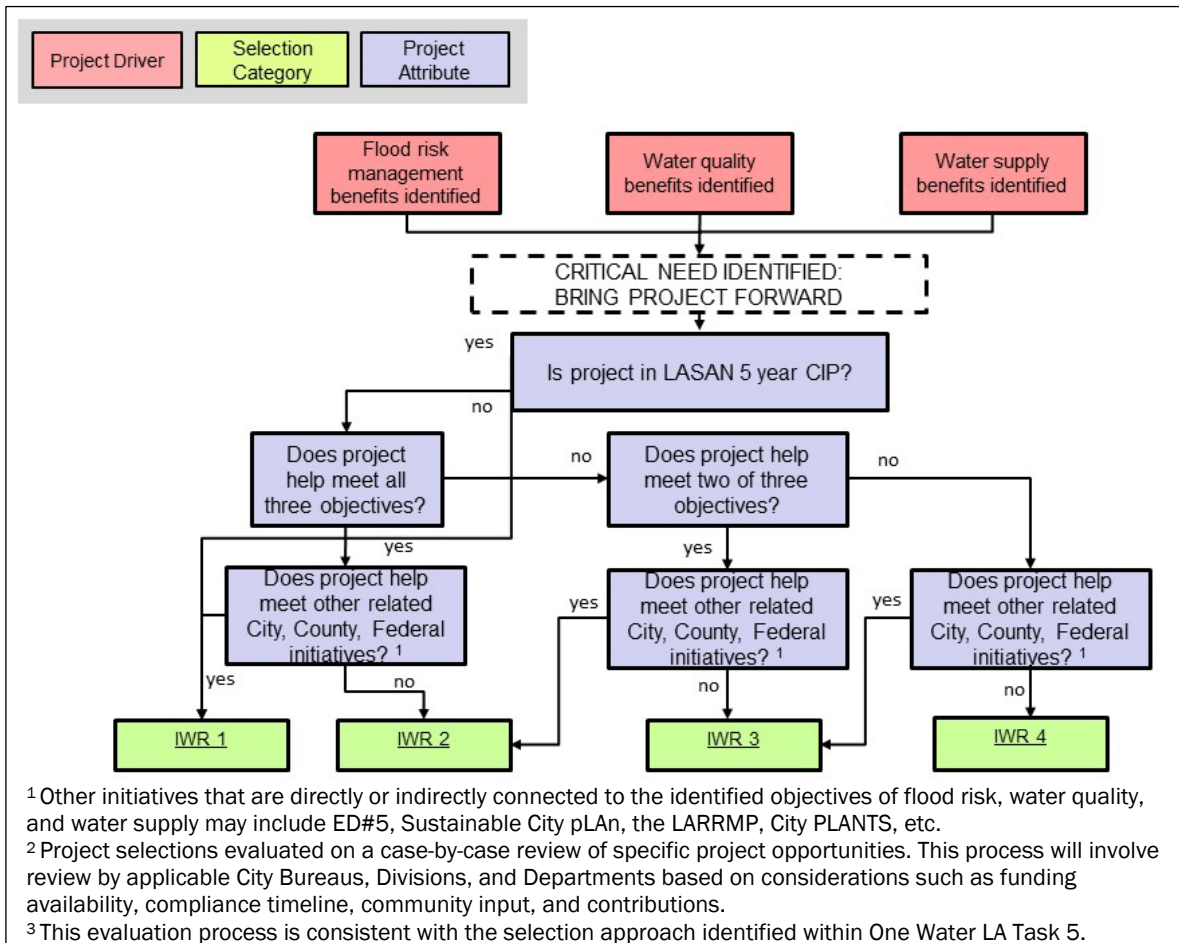

Figure 8.6 Integrated Water Resources System Considerations

8.7 STORMWATER IMPROVEMENT PROGRAM

To help the City meet its stormwater and urban runoff management needs over the next 25 years, a City SIP consisting of three phases was developed. The development of the SIP relied on results from multiple watershed planning efforts from both public and private agencies within the City's jurisdiction. Projects proposed within the City's jurisdiction from previous watershed planning efforts were compiled and evaluated using the three-legged stool evaluation criteria. Only City-involved projects (either as lead agency or in partnership with other agencies) are included in the three SIP phases:

- 5-year SIP phase (2017-2022);⁵
- 10-year SIP phase (2022-2027); and
- 25-year SIP phase (2027-2042).

8.7.1 Project Database Development

As a key component to the stormwater management aspect of the One Water LA 2040 Plan, a single database of planned and potential projects was developed to compile ongoing stormwater management efforts from multiple agencies operating within the City. The database is foundational to the development of the SIP as it provides a common platform to evaluate all projects against standardized stormwater project selection criteria. Existing stormwater, urban runoff, and watershed planning efforts that identified projects within and upstream of the City's jurisdiction were compiled into the database.

Some of these projects included Green Streets, which are a critical component to the City's stormwater management system since they allow for the development of stormwater projects on a distributed basis. Each of the five City-led EWMPs presented planning-level targets for Green Streets implementation, based on EWMP-specific implementation metrics and spatial resolution. Recognizing that near-term projects proposed in these Green Streets plans are not sufficient in and of themselves to meet the LARWQCB-approved EWMP implementation targets, a Green Streets screening analysis was conducted herein to develop City-wide, catchment-specific Green Streets programs. Table 8.4 summarizes the planned implementation schedule for various "blocks" of green streets based on applicable regulatory compliance deadlines.

⁵ The 5-year CIP is based on LASAN's 2015 5-year stormwater CIP, with the addition of new projects developed within the One Water framework. Please see Chapter 7 of the SWFP (Volume 3) for specific changes made to the original 5-year stormwater CIP.

Table 8.4 Green Streets Implementation Schedule Comparison Summary Report One Water LA 2040 Plan			
Green Streets Block	EWMP Milestone Schedule	WMA	Regulatory Compliance Attainment
Block A	2021	BC	BC Metal and Bacteria TMDLs - 100%
		SMB	SMB J2/3 - SMB Beach Bacteria TMDL -100% Mdr Mother's Beach and Back Basins Bacteria TMDL - 100%
	2024	ULAR	LA River Metals TMDL - 50%
Block B	2026	DC	DC/LA Harbor Waters Toxic Pollutant TMDL - 50%
	2028	ULAR	LA River Metals TMDL - 100% ⁽¹⁾
Block C	2032	DC	DC/LA Harbor Waters Toxic Pollutant TMDL - 100%
		ULAR	LA River Bacteria TMDL - 44.5% ⁽²⁾
Block D	2037	ULAR	LA River Bacteria TMDL - 100%
Notes:			
(1) Block definitions for the ULAR WMA is based on two TMDLs. According to the ULAR EWMP, all Green Streets are required to meet the LA River Metals TMDL. Hence, the Green Streets programs in the ULAR WMA are separated into Block A and Block B			
(2) This milestone is not based on regulatory deadlines, but was estimated by interpolating between the end of Block B (2028) and the final LA River Bacterial TMDL compliance attainment at the end of Block D (2037)			

A total of 445 Green Streets Block programs were developed. The details of the established methodology and results are presented in Section 8.7.2 below and Appendix E of the SWFP (see Volume 3). In addition to these Green Streets projects, low flow diversion projects and climate resiliency projects developed within the One Water LA 2040 Plan were included in the database and the resulting SIP.

8.7.2 Stormwater Project Selection Overview

After compiling all identified stormwater projects into a single project database, each project was evaluated based on the three-legged stool selection approach. The project list was then sorted by the following selection factors:

- Primary Selection Factors:
 - Already Fully Funded Stormwater Projects
 - ◆ 2015 LASAN 5-year CIP
 - ◆ SCMP Projects⁶
 - Integrated Water Resources Selection Category
- Secondary Selection Factors:
 - Water Quality Selection Category
 - Water Supply Selection Category
 - Flood Risk Management Selection Category

⁶ Not all SCMP projects were fully funded by the time One Water LA 2040 Plan was completed.

The selection process was chiefly dependent on the four primary selection factors. The secondary selection factors were only evaluated if the primary selection factors of two projects were found to be identical.

8.7.3 Stormwater Database Overview

In total, 1,201 stormwater management projects⁷ were identified and evaluated in accordance to the three-legged stool evaluation criteria. The complete selection outcome table is presented in Appendix B of this Summary Report and Appendix F of the SWFP (see Volume 3). Three sets of figures have been created to show locations of the selected projects for the categories of:

1. Planned Regional Grey Infrastructure
2. Planned Regional Green Infrastructure
3. Planned Distributed Green Infrastructure.

Out of the 1,201 projects included in the project database, 59 projects are not affiliated with the City. It is assumed that the City will not provide funding for these projects. The remaining 1,142 City-involved projects were categorized into the 5-year, 10-year, and 25-year SIP phases. The 5-year SIP phase was based on LASAN's 2015 5-year stormwater and green infrastructure Capital Improvement Program with enhancements made to incorporate new information within the One Water framework. The capital cost of the 5-year SIP phase was revised accordingly. The total capital cost of non-5-year SIP phase and City-involved projects was divided by 20 to obtain the average annual SIP budget from year 2022 to 2042. The 10-year and 25-year SIP phase budgets were computed by multiplying the annual SIP budget by 5 and 15, respectively.

The current SIP consists of 1,142 specific projects with an estimated total capital cost of \$5.6 billion. This capital cost estimate differs from the City's estimated EWMP compliance obligation of \$7.4 billion. The reason for this discrepancy is that the City's financial obligation towards EWMP compliance was estimated based on the EWMP compliance metric⁸. A significant portion of the EWMP compliance metric has not yet been converted into actual projects. As a result, the cost is not reflected in the SIP capital cost. The City plans on refining the EWMP compliance obligation cost and identifying additional projects to cover the EWMP compliance metric through the EWMP adaptive management framework and through the distributed solutions identified in the One Water LA 2040 Plan recommended policies and programs.

Of the 1,142 projects identified in the SIP, 714 projects with an estimated total capital cost of \$3.1 billion are either regional projects that were developed during the EWMP development, or Green Streets programs that were developed in accordance with the respective with the EWMP

Category 1, defined as planned regional grey infrastructure projects (including storm drain improvement), includes 328 projects. Locations are shown in Appendix G of the SWFP (see Volume 3) on Figures G.1 through G.11

Category 2, defined as planned regional green infrastructure projects, includes 252 projects. Locations are shown in Appendix H of the SWFP (see Volume 3) on Figures H.1 through H.11

Category 3, defined as planned distributed green infrastructure projects, includes 621 projects. Locations are shown in Appendix E of the SWFP (see Volume 3) on Figure E.1 through E.11

⁷ Including the 445 Green Streets programs identified in Section 7.3.1.

⁸ Static BMP capture volume

compliance metric. Table 8.5 specifically summarizes the resultant Green Streets programs cost by WMA. As shown, the total estimated capital cost of all Green Streets programs is approximately \$1.1 billion. A detail breakdown of targets and cost of each Green Streets programs is presented in Appendix E of the SWFP (see Volume 3).

Table 8.5 Green Streets Programs Cost Summary Summary Report One Water LA 2040 Plan					
		Green Streets Implementation Target⁽¹⁾			
WMA	Block	Length (mi)	Capture Volume (AF)	Estimated Capital Cost (million \$)	Estimated O&M Cost (million \$/year)
Ballona Creek	Block A	61	223	\$312	\$19
Santa Monica Bay	Block A	14	52	\$73	\$4
	Block B	4	16	\$22	\$1
Dominguez Channel	Block C	4	16	\$22	\$1
	Block A	70	254	\$356	\$21
Upper Los Angeles River	Block B	70	254	\$356	\$21
	Total⁽²⁾	224	815	\$1,140	\$70

Notes:
 (1) Targets calculated as equivalent EWMP implementation targets subtracting lengths/capture volumes from already planned Green Streets projects.
 (2) Totals may not add up due to rounding.
Abbreviations:
 WMA = Watershed Management Area; AF = acre-feet

The estimated total project capital cost of \$3.1 billion is included as part of the City's \$7.4 billion estimated obligation toward EWMP compliance. The remaining 428 SIP projects with an estimated total capital cost of \$2.5 billion have been identified by City agencies that were not involved with EWMP development (e.g., LADWP). Although these projects were not evaluated as being part of the City's EWMPs, further studies are recommended to quantify the water quality benefits of these projects and to evaluate their eligibility toward EWMP compliance.

In summary, the City's SIP makes significant progress towards the City's EWMP compliance obligations, but it is not a standalone database to fully cover this obligation since not all necessary projects were specifically identified in the EWMPs. The SIP will be updated regularly to evaluate projects proposed by non-EWMP City agencies for their eligibility toward EWMP compliance and to incorporate additional projects developed through the EWMP adaptive management framework and through the distributed solutions identified in the One Water LA 2040 Plan recommended policies and programs. The LID ordinance, along with any future stormwater ordinances, will be reviewed periodically to assess their overall impact on projects needed to achieve water quality objectives.

The recommended SIP is summarized by project category and planning phase on Figure 8.7. The total estimated Capital Cost of the SIP is \$5.6 billion with the vast majority (90 percent) allocated to regional and distributed green infrastructure, while only 10 percent of the SIP is for regional grey infrastructure projects.

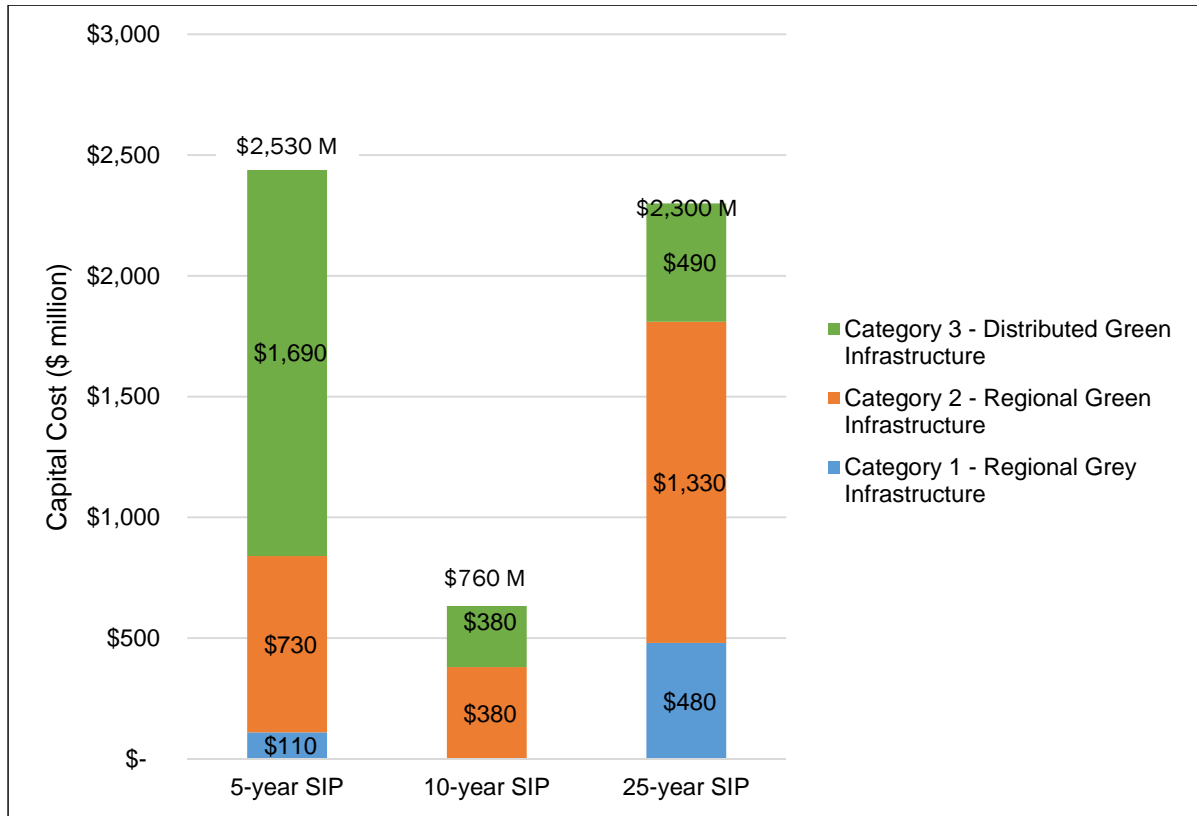

Figure 8.7 Capital Cost Distribution by Project Category and SIP Phase

The SIP will result in increased O&M obligations as projects come on line. Moreover, the SIP will require regular updates to incorporate changes to meet compliance milestones as well as water supply and flood risk mitigation objectives. Hence, the 5-year, 10-year, and 25-year SIP phases will need to be periodically revised by re-executing the project selection methodology described herein.

8.8 STORMWATER RELATED POLICY RECOMMENDATIONS

In addition to the stormwater projects included in the database and SIP, parcel-based solutions are an important component of the distributed green infrastructure program. The LID ordinance, along with any future stormwater ordinances, will be reviewed periodically to assess their overall impact on projects needed to achieve water quality objectives. Many of the Plan’s recommended policies are intended to increase implementation and improve performance of distributed BMPs. The One Water LA policies outline strategies to simplify processes and remove barriers to installing green infrastructure, develop incentives and property owner recognition programs, increase training and education, develop maintenance protocols and increase partnership opportunities with non-profit partners. A full list of the policies can be found in Volume 7.

One of the recommended policies (#5) is to develop robust stormwater pollution source control education measures to increase awareness and public participation. Stakeholders also identified specific recommended action items (AC1 and AC6) related to source control. A full list of the policies and action items can be found in Chapter 9 and Appendix E of the Summary Report.

8.9 FINANCIAL STRATEGY

The City has an urgent need to identify sources of funding for the implementation of the SIP to meet compliance deadlines. Chapter 8 of the SWFP examines the funding needs for that program, and the challenges facing the City to raise necessary funds. It examines the conceptual needs for funding based upon a simplified set of assumptions, reviews the adequacy of existing sources of funding for stormwater projects, and identifies possible sources of funding in the future, comparing potential funding sources with projected funding requirements.

8.9.1 Amortized SIP Cost

A simplified financial analysis was conducted to amortize the cost of the City's SIP. It was assumed that 20 percent of the capital cost would be funded as Pay-As-You-Go (PAYGO), while the remaining 80 percent of the capital cost is financed based on an interest rate of 4.5 percent for 30 years. In this assumed scenario, an inflation factor of two percent is applied to costs and simplified assumptions are used regarding the schedule for construction and bond issuances. The O&M costs of the SIP are assumed to be proportional to the capital cost allocated to each category. In addition, future forecasts include estimated O&M for existing stormwater quality projects of approximately \$44 million dollars per year in constant dollars. Figure 8.8 illustrates the estimated/projected annual cost obligation throughout the planning period.

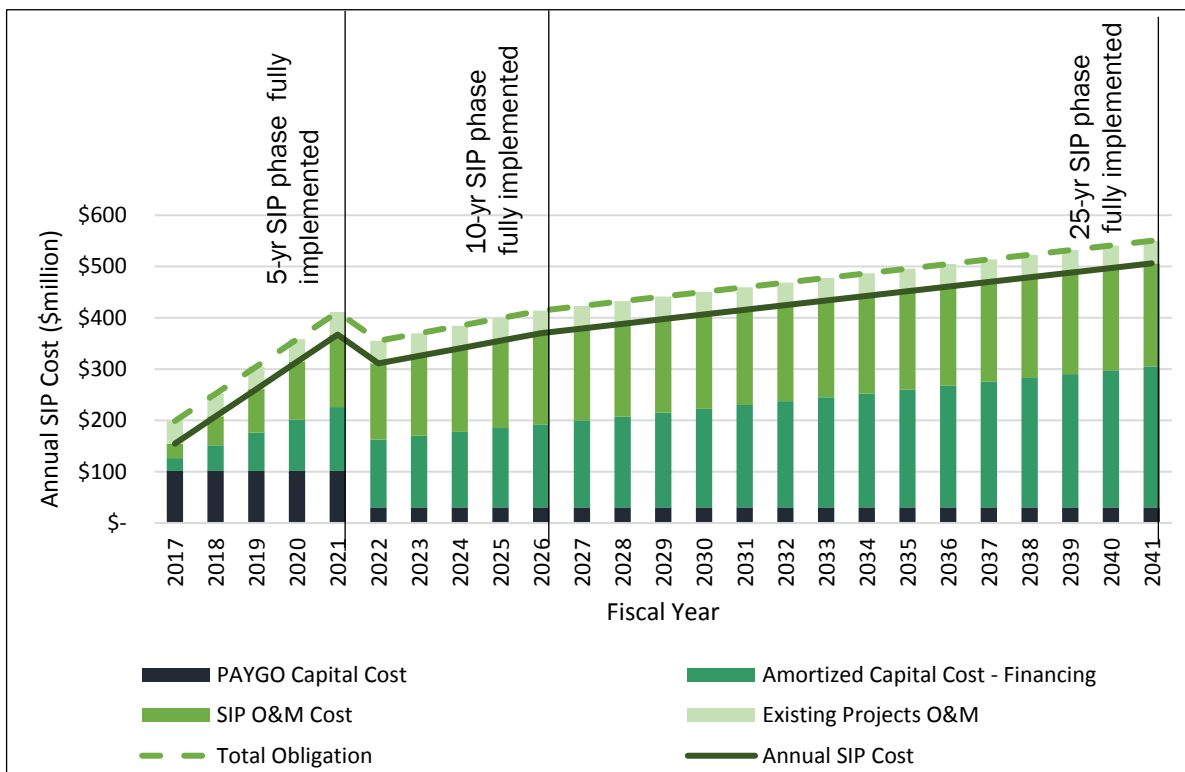

Figure 8.8 Amortized Annual SIP Cost through Year 2042

As shown on Figure 8.8, the beginning annualized cost obligation for the SIP in year 2017 is estimated at \$188 million. As more projects are implemented each year, the total cost obligation increases to \$387 million at year 2021 when the 5-year SIP phase projects are implemented. Starting at year 2022, the capital PAYGO is updated based on the 10-year SIP phase cost. The resultant annual cost obligation for year 2022 is \$341 million. As a result of the increasing O&M and amortized financing costs, the annual cost then gradually increases to \$403 million by the end of year 2026 when all 10-year SIP phase projects are implemented. Starting at year 2027, the PAYGO capital cost is updated again based on the 25-year SIP phase cost. The resultant annual cost for year 2027 is \$403 million. The annual cost obligation reaches a maximum at \$549 million at year 2042 when all SIP projects are implemented. These annualized cost obligations are representative of the total revenue requirements to fund the SIP.

8.9.1.1 Benefits of Stormwater Investments

The City could benefit from identifying additional means to fund and implement the stormwater improvement plan. Not only would the City avoid potential compliance penalties amounting to thousands of dollars per day for each TMDL violation, the compliance program offers the substantial ancillary benefits illustrated on Figure 8.9. To realize these benefits, the City should continue to explore financing options in greater detail, innovate project delivery options; and continue to pursue additional sources of funding



Figure 8.9 Non-monetary Economic Benefits of Stormwater Investments

8.9.2 Current Funding Mechanisms

Stormwater management is one of many objectives within the City and just one part of LASAN's vast responsibilities. It will be very challenging for the City to develop adequate sources of revenue to address these estimated cost requirements described above. Figure 8.10 compares existing revenue sources with the conceptual annual cost obligation of the City's stormwater management program.



Figure 8.10 Deficiencies between Existing Revenues and Project Costs

As depicted on Figure 8.10, the conceptual SIP cost cannot be adequately funded from existing revenue sources. Current revenue sources plus assumed continued successes in obtaining grant funding will generate approximately \$31 million per year, which is less than O&M costs for existing stormwater quality management projects implemented by LASAN/LABOE and far less than the O&M obligations when considering increased O&M from the SIP. Further, when compared to the estimated future annual cost obligations for Capital and O&M associated with existing programs and future SIP, the deficiency is dramatic. The annual cost obligation exceeds existing revenue sources immediately and the deficiency grows over time as new projects are contemplated and the effects of inflation tend to lessen the buying power of the Stormwater Pollution Abatement Charge (SPAC) fee relative to costs that will increase with inflation.

8.9.3 Assumptions for Future Funding

In recognition of the funding deficiency described above, the SWFP summarizes a set of key assumptions regarding potential future sources to fund the SIP, in order to allow for a presentation of pertinent issues and a conceptual description of an approach to future funding. Figure 8.11 demonstrates the application of all estimated future sources of revenue and outside funding sources toward the conceptual annual needs for funding. As shown, sufficient funding to address the City's stormwater funding needs has not been identified. Table 8.6 summarizes the remaining deficit at each milestone year.

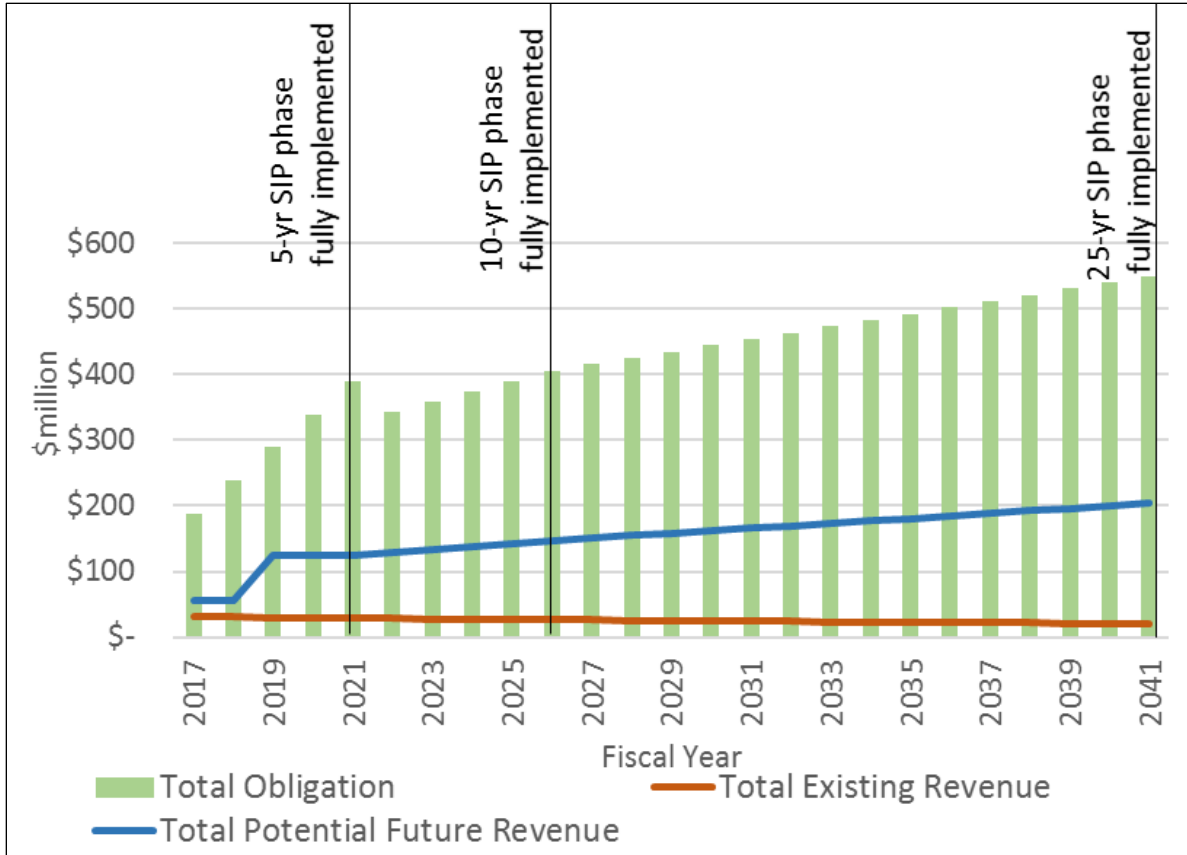

Figure 8.11 Comparison between Potential Funding and Cost Obligation

Milestone Year	Total Obligation	Existing Funding Revenues	Future Funding Revenues	Deficit	Cumulative Deficit
2017 (First year the of 5-year SIP Phase)	\$199	\$21	\$28	(\$150)	(\$150)
2021 (Last year of the 5-year SIP Phase)	\$411	\$19	\$109	(\$283)	(\$1,050)
2022 (First year of the 10-year SIP Phase)	\$355	\$19	\$115	(\$221)	(\$1,270)
2026 (Last year of the 10-year SIP Phase)	\$414	\$17	\$138	(\$259)	(\$2,250)
2027 (First year of the 25-year SIP Phase)	\$423	\$17	\$141	(\$266)	(\$2,510)
2041 (Last year of the 25-year SIP Phase)	\$550	\$12	\$182	(\$356)	(\$6,920)

Notes:
 (1) All costs reported in million dollars
 (2) The total obligation covers the SIP cost only and does not fully cover the City's obligation to the EWMPs.

As presented in Table 8.6 and depicted on Figure 8.10, the deficit between funding sources identified to date and the conceptual annual cost obligation ranges from \$150 million in constant dollars at year 2017 to \$356 million in constant dollars at year 2042. This equates to an estimated cumulative deficit in 2042 of \$6.9 billion. On average, the funding sources identified to-date would supply approximately 1/3 of the total funding obligation outlined in this SWFP.

8.10 CONCLUSIONS AND RECOMMENDATIONS

The Stormwater and Urban Runoff Facilities Plan guides the City and its partners to help meet the Mayor's goals of increasing stormwater capture, reducing potable water use, implementing green streets, and building more sustainable and resilient infrastructure. The Plan identifies over 1,200 project opportunities required to help meet these goals while providing improved flood protection, water quality benefits, and/or water supply enhancements. Most of these project opportunities are distributed in nature, with the clear majority being green streets. This focus on green streets moves away from the traditional prioritization of large-scale regional/centralized facilities, allowing a densely-urbanized city like Los Angeles to implement multi-benefit projects without the often impossible-to-find space that these types of projects typically require.

To implement such a broad-reaching plan, significant integration is necessary, both internally and externally. Within the City, integrating management processes for decision making and selection of projects is critical to project implementation. Departments need to work collectively to ensure that there is cohesion and agreement in the entire life of each project, from concept planning, funding, and design through construction, optimization, and operations. Externally, partnerships with nonprofit organizations, businesses, residents, and other local, regional, State, and Federal agencies are critical to the success of this Plan. Such partnerships are critical not only to the funding and implementation of individual projects, but to long-term regulatory compliance, a healthier environment, and the overall well-being of the people of Los Angeles.

Additional conclusions and recommendations can be found in Chapter 9 of the SWFP (Volume 3).

PLAN RECOMMENDATIONS AND IMPLEMENTATION STRATEGY

Chapter 9 presents and summarizes the One Water LA 2040 Plan (Plan) recommendations, associated timelines, and implementation strategy. The Chapter begins with a description of the categories of Plan recommendations, followed by a discussion of the project timelines and phasing assumptions. Subsequently, the Plan recommendations are presented by category, in the following order:

- Current Integration Opportunities
- Future Integration Opportunities
- Wastewater Projects
- Stormwater Projects
- Policies and Programs

For each of these categories, phasing assumptions, cost estimates, and a cost summary by phase are discussed. Subsequently, the project timelines summary is presented. The chapter concludes with the adaptive implementation strategy, which includes a discussion of the wide variety of project triggers that were identified, and used to develop a trigger-based implementation strategy. Various implementation strategies are then described and illustrated with trigger charts. This trigger-based implementation process allows adaptive decision-making as system conditions and needs evolve over time.

9.1 CATEGORIES OF PLAN RECOMMENDATIONS

This section presents the Plan's recommended projects, programs, and policies. These recommendations are organized in the following categories: (1) Stormwater Projects; (2) Wastewater Projects; (3) Current Integration Opportunities; (4) Future Integration Opportunities; and (5) Policies and Programs. For each category, the phasing methodology and cost estimating assumptions are defined below and summarized in Section 9.3 through 9.7.

- **Stormwater Projects**– This category includes stormwater projects that help meet water quality regulations, address flooding risks, and/or provide water supply benefits by recharging stormwater in underlying aquifers. These stormwater projects are described in detail in the Stormwater and Urban Runoff Facilities Plan (see Chapter 8 and Volume 3 of this Plan).
- **Wastewater Projects** – This category includes improvement projects for the four water reclamation plants (WRPs) and the wastewater collection systems in order to address existing deficiencies and meet future system needs. The wastewater projects are described in detail in the Wastewater Facilities Plan (WWFP) (see Chapter 7 and Volume 2 of this Plan).

- **Current Integration Opportunities** – This category includes current project ideas that have, or could include, a water management component and that require collaboration of multiple City departments and/or regional agencies. Five current projects were selected as case studies to demonstrate and test how water management benefits can be integrated in a project through multi-agency collaboration. Current integration opportunities are discussed in detail in Chapter 5.
- **Future Integration Opportunities** – This category includes future concept ideas that could help meet stormwater management goals, reduce flooding, improve stormwater and receiving water quality, and support local water supplies identified in the Sustainable City pLAN. These opportunities could also help the City improve cost-effectiveness, and allow for more coordinated, collaborative, and timely implementation of water projects, programs, and management strategies. Future integration opportunities are discussed in detail in Chapter 6.
- **Policies and Programs** - This category includes policies and programs that would facilitate better communication between departments and agencies, advance One Water LA objectives more effectively, and align with One Water LA's vision. The policies and programs developed include ideas and suggestions from both the Steering Committee and Stakeholders representing a wide variety of interests and perspectives including non-profits, the business community, commercial and industrial interests, and neighborhood council representatives.

The One Water LA 2040 Plan recommendations are primarily focused on water-related projects and programs that require multi-department or multi-agency coordination and collaboration. As such, the information presented in this Chapter is not a City-wide capital improvement plan (CIP). Participation in One Water LA by City departments and regional agencies is voluntary and each department/agency has different priorities and funding constraints. Impacts to all relevant CIPs should be considered in assessing feasibility of these projects and programs prior to implementation.

Each City department has many projects and programs that are being implemented independent of One Water LA in order to meet each departments' core responsibilities and missions. For example, Los Angeles Department of Water and Power's (LADWP) water mission is to provide customers with reliable, high quality and competitively priced water services in a safe and publicly and environmentally responsible manner. To this end, the LADWP has a multitude of projects and activities being implemented independent of the Plan. First, LADWP implements a whole host of water conservation programs with conservation measures in the areas of pricing, public information, school education, residential, commercial/industrial/government, landscape, system maintenance, and local water supply development in accordance with their UWMP. Some examples of water conservation programs that are further described in Chapter 3 include the Save the Drop Campaign and the Water Loss Reduction Program. In addition, LADWP performs extensive operations and maintenance (O&M) of the Los Angeles Aqueduct (LAA) system, including maintenance of the aqueduct itself and associated reservoirs, as well as ongoing environmental enhancement and mitigation. Similarly, LADWP conducts ongoing O&M of its entire distribution system and implements a multitude of infrastructure projects, such as replacing or upgrading major system components, as well as working on trunk lines, connections, and distribution mains. These are examples of projects and programs that are not included in this Plan.

Similarly, Los Angeles Sanitation's (LASAN) primary responsibility is to collect, clean and recycle solid and liquid waste generated by residential, commercial, and industrial users in the City and surrounding communities. There are many projects and programs associated with these responsibilities that are not described in this Plan, including, but not limited to, LASAN's day-to-day operation of its wastewater collection system, watershed protection program, and solid waste handling services. LASAN operates and maintains the largest wastewater treatment and collection systems in the United States that includes more than 6,700 miles of public sewers that convey about 400 million gallons per day of flow from residences and businesses to the LASAN's four water reclamation plants. The watershed protection focuses on both flood control and pollution reduction while ensuring Los Angeles' compliance with federal, state and local regulations and reducing the amount of stormwater pollution flowing into and through regional waterways. In addition, LASAN is responsible for the collection and removal of solid materials and waste in the entire City with over 750 vehicles, most of which use clean fuel to reduce emissions.

Similarly, to LADWP and LASAN, all other City departments have many projects and programs that are being implemented independent of One Water LA. The Plan recommendations presented in this Chapter are limited to those water-related projects that require collaboration from multiple city departments and/or regional agencies.

9.2 PHASING PERIODS

The recommended projects and programs identified in this Plan are grouped in three separate phases that cover the 23-year period from 2018 to the planning horizon of year 2040. The three project phases identified for the Plan are:

1. Near-term phase – This phase includes projects, programs, and policies that could be implemented in the "near-term," defined as the three-year period from 2018 through 2020.
2. Mid-term phase – This phase includes projects, programs, and policies that could be implemented in the "mid-term," defined as a 10-year period from 2021 through 2030.
3. Long-term phase – This phase includes projects, programs, and policies that could be implemented in the "long-term," defined as the 10-year period from 2031 through 2040.

The phasing presented in this Plan is subject to change due to the wide range of uncertainty and factors that could influence future project needs and implementation. When preparing plans spanning over two decades, it is expected that underlying assumptions, system conditions, funding opportunities, and regulatory conditions will change. Additionally, certain project triggers have the potential to influence project phasing and implementation strategies. It is therefore anticipated that actual project phasing, and costs will need to be further developed, monitored, and updated on an as-needed basis. Similar to the 2006 Water Integrated Resources Plan (Water IRP), it is the City's intent that this Plan will be updated every five to ten years.

9.3 CURRENT INTEGRATION OPPORTUNITIES

Current integration opportunities are potential and/or planned projects that have or could include a water management component and that require collaboration of multiple City departments and/or regional agencies. The overarching goal of these projects is to demonstrate how water management benefits can be integrated in a project through multi-agency collaboration.

As described in Chapter 5, a list of current integration opportunities was created. The purpose of obtaining the list of current integration opportunities was to create practical examples of interdepartmental/interagency collaboration, identify agreements and policies needed to resolve complexities hindering project implementation, and to highlight "quick success" stories that align with the One Water LA vision and provide multiple benefits (i.e., stormwater capture, recycled water expansion). This effort resulted in the identification of 44 current integration opportunities, which were subsequently narrowed down to the top 10 current integration opportunities, which are also referred to as Case Studies (see Chapter 5). The top 10 current integration opportunities are listed in Table 5.3, while the approximate locations of the 44 current integration opportunities that have a spatial location are also depicted on Figure 9.1. Some project locations are not depicted as the project location is still unknown or could involve multiple sites throughout the City, such as "Bicycle Friendly Street Intersection Enhancements".

As shown in Table 5.3, these top 10 current integration opportunities represent a broad mix of project components, lead departments/agencies, and collaboration partners. Moreover, the top 10 projects include five stormwater projects, one recycled water project, while four projects include a combination of both.

The remaining 34 current integration opportunities are tabulated in Appendix B of TM 3.1 (Current Integration Opportunities Case Study Selection) included in Volume 5 of this Plan. In addition, other integration opportunities were captured in TM 3.2 (Current Integration Opportunities – Case Studies, included in Volume 5 of this Plan) to provide a "living" project/concept ideas list. This listing includes new ideas from stakeholders and other projects that emerged during the development of this Plan.

9.3.1 Phasing Assumptions

The 44 current integration opportunities identified during the development of this Plan represent a wide range of projects. They are called current opportunities because these are identified at the time of this plan preparation and could potentially be implemented in the near-term. However, some projects are far along in the planning and design stage and are nearly ready or already in construction, whereas other projects only reflect a conceptual idea and anything in between. As the majority of projects are still in the early planning stage, it is assumed that some opportunities would not be implemented due to new conditions, cost-effectiveness, or other implementation concerns. For the phasing in this Plan, it is therefore assumed that only 75-80 percent of the current integration opportunities would actually be implemented within the planning horizon of year 2040. Hence, the phasing plan presented herein is based on the implementation of 35 of the currently identified integration opportunities. Moreover, some opportunities may not be implemented in the near- or even mid-term phase due to a variety of implementation challenges and/or changed conditions.

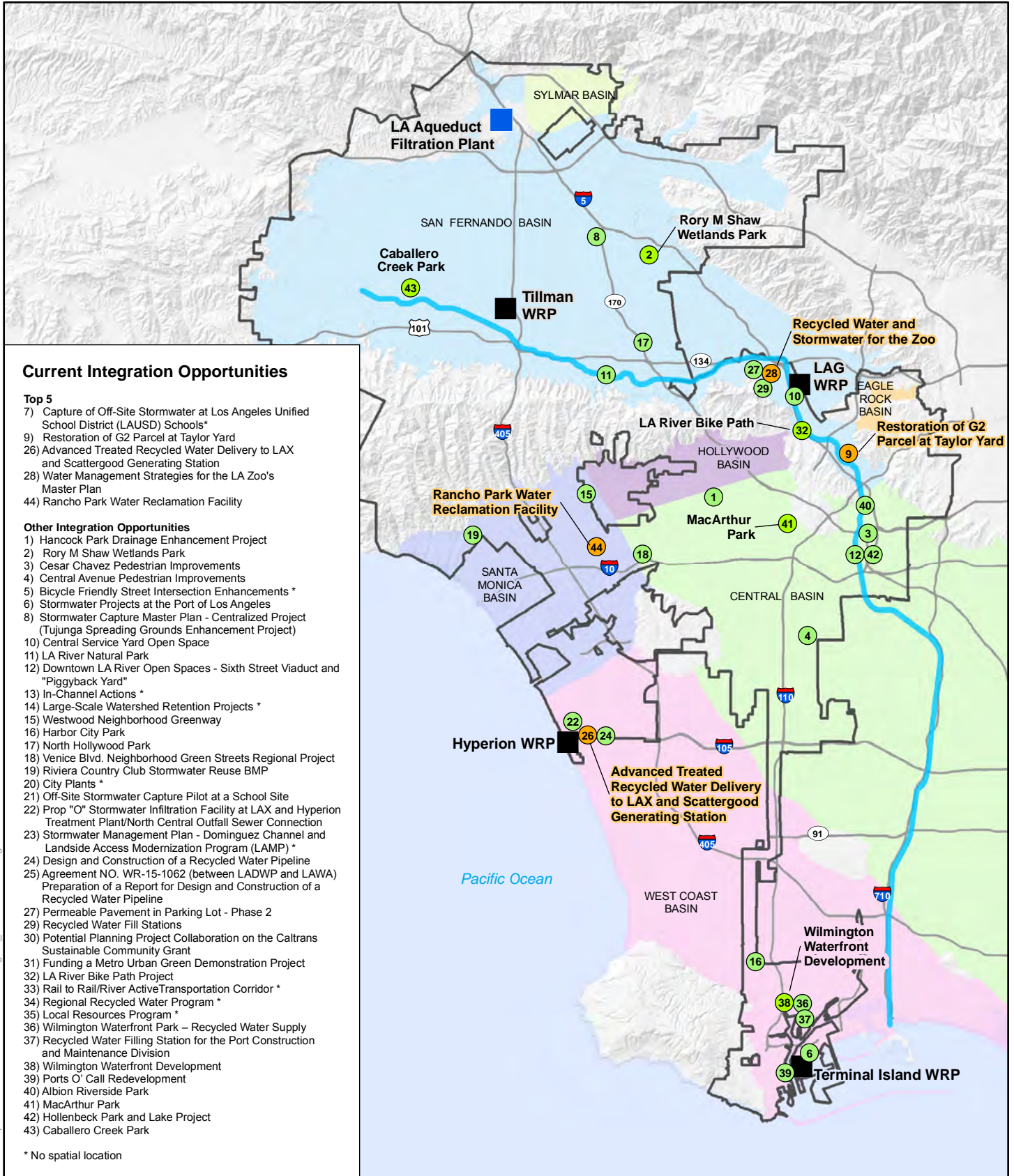

Current Integration Opportunities

- Top 5**
- 7) Capture of Off-Site Stormwater at Los Angeles Unified School District (LAUSD) Schools*
 - 9) Restoration of G2 Parcel at Taylor Yard
 - 26) Advanced Treated Recycled Water Delivery to LAX and Scattergood Generating Station
 - 28) Water Management Strategies for the LA Zoo's Master Plan
 - 44) Rancho Park Water Reclamation Facility
- Other Integration Opportunities**
- 1) Hancock Park Drainage Enhancement Project
 - 2) Rory M Shaw Wetlands Park
 - 3) Cesar Chavez Pedestrian Improvements
 - 4) Central Avenue Pedestrian Improvements
 - 5) Bicycle Friendly Street Intersection Enhancements *
 - 6) Stormwater Projects at the Port of Los Angeles
 - 8) Stormwater Capture Master Plan - Centralized Project (Tujunga Spreading Grounds Enhancement Project)
 - 10) Central Service Yard Open Space
 - 11) LA River Natural Park
 - 12) Downtown LA River Open Spaces - Sixth Street Viaduct and "Piggyback Yard"
 - 13) In-Channel Actions *
 - 14) Large-Scale Watershed Retention Projects *
 - 15) Westwood Neighborhood Greenway
 - 16) Harbor City Park
 - 17) North Hollywood Park
 - 18) Venice Blvd. Neighborhood Green Streets Regional Project
 - 19) Riviera Country Club Stormwater Reuse BMP
 - 20) City Plants *
 - 21) Off-Site Stormwater Capture Pilot at a School Site
 - 22) Prop "O" Stormwater Infiltration Facility at LAX and Hyperion Treatment Plant/North Central Outfall Sewer Connection
 - 23) Stormwater Management Plan - Dominguez Channel and Landside Access Modernization Program (LAMP) *
 - 24) Design and Construction of a Recycled Water Pipeline
 - 25) Agreement NO. WR-15-1062 (between LADWP and LAWA) Preparation of a Report for Design and Construction of a Recycled Water Pipeline
 - 27) Permeable Pavement in Parking Lot - Phase 2
 - 29) Recycled Water Fill Stations
 - 30) Potential Planning Project Collaboration on the Caltrans Sustainable Community Grant
 - 31) Funding a Metro Urban Green Demonstration Project
 - 32) LA River Bike Path Project
 - 33) Rail to Rail/River Active Transportation Corridor *
 - 34) Regional Recycled Water Program *
 - 35) Local Resources Program *
 - 36) Wilmington Waterfront Park - Recycled Water Supply
 - 37) Recycled Water Filling Station for the Port Construction and Maintenance Division
 - 38) Wilmington Waterfront Development
 - 39) Ports O' Call Redevelopment
 - 40) Albion Riverside Park
 - 41) MacArthur Park
 - 42) Hollenbeck Park and Lake Project
 - 43) Caballero Creek Park

* No spatial location

Legend

- Existing Water Reclamation Plant (WRP)
- City of Los Angeles
- Existing Water Filtration Plant
- Groundwater Basin Source: LACDPW
-
-
-
-
-
-
-
-
-
-
-
-
-
-
-
-
-
-
-
-
-
-
-
-
-
-
-
-
-
-
-
-
-
-
-
-
-
-
-
-
-
-
-
-
-
-
-
-
-
-
-
-
-
-
-
-
-
-
-
-
-
-
-
-
-
-
-
-
-
-
-
-
-
-
-
-
-
-
-
-
-
-
-
-
-
-
-
-
-
-
-
-
-
-
-
-
-
-
-
-
-
-
-
-
-
-
-
-
-
-
-
-
-
-
-
-
-
-
-
-
-
-
-
-
-
-
-
-
-
-
-
-
-
-
-
-
-
-
-
-
-
-
-
-
-
-
-
-
-
-
-
-
-
-
-
-
-
-
-
-
-
-
-
-
-
-
-
-
-
-
-
-
-
-
-
-
-
-
-
-
-
-
-
-
-
-
-
-
-
-
-
-
-
-
-
-
-
-
-
-
-
-
-
-
-
-
-
-
-
-
-
-
-
-
-
-
-
-
-
-
-

The phasing methodology used for implementation of 35 current integration opportunities has been divided as follows:

- Near-term phase (2018-2020) – It is assumed that the top five Case Studies listed in Table 5.3 would begin implementation in this phase. For planning purposes, all costs associated with these top five integration opportunities are included in this phase. However, due to the short duration of this phase it is likely that most projects would not be completed until early in the mid-term phase.
- Mid-term phase (2021-2030) – It is assumed that the remaining five top 10 projects (projects ranked 6-10 in Table 5.3) would be implemented, along with 15 other projects either selected from the list of 44 opportunities or identified through continued department and agency collaboration.
- Long-term phase (2031-2040) – It is assumed that 10 additional projects would be implemented in this last phase.

9.3.2 Cost Estimates

Detailed estimates for the top four projects have been prepared and are described in Chapter 5 of this Plan. For all other opportunities, it is noted that there is wide cost range and lack of cost data at this time. Based on the cost range of the Case Studies developed as part of this Plan, the other integration opportunities have been assigned a placeholder cost estimate of \$50 million per project. In addition, cost-sharing agreements would need to be developed for all of these current integration opportunities to allocate costs among project partners. A cost summary for the 35 current integration opportunities is provided in Table 9.1.

Table 9.1 Cost Summary of Current Integration Opportunities				
Summary Report				
One Water LA 2040 Plan				
Project Description⁽¹⁾	Project Phase⁽²⁾			
	Near-Term (2018-2020) (\$M)	Mid-Term (2021-2030) (\$M)	Long-Term (2031-2040) (\$M)	Total (2018-2040) (\$M)
Case Study 1	\$58	\$0	\$0	\$58
Case Study 2	\$51	\$0	\$0	\$51
Case Study 3	\$17	\$0	\$0	\$17
Case Study 4	\$76	\$0	\$0	\$76
Case Study 5	\$95	\$0	\$0	\$95
Case Study 6	\$0	\$50	\$0	\$50
Case Study 7	\$0	\$50	\$0	\$50
Case Study 8	\$0	\$50	\$0	\$50
Case Study 9	\$0	\$50	\$0	\$50
Case Study 10	\$0	\$50	\$0	\$50
15 Other Current Integration Opportunities	\$0	\$750	\$0	\$750
10 Other Current Integration Opportunities	\$0	\$0	\$500	\$500
Total	\$297	\$1,000	\$500	\$1,797

Notes:

(1) Case Studies 6-10 and all other integration opportunities are assigned a placeholder capital cost of \$50M. Actual cost estimated pending further study and cost sharing agreements.

(2) Project phasing assumptions made for planning purposes only. Actual project phasing and costs will need to be further developed, monitored, and updated on an as-need basis.

9.3.3 Cost Summary by Phase

The estimated costs of current integration opportunities are presented by phase on the bar chart on Figure 9.2. These include capital costs for the near-term, mid-term, and long-term phases. As shown, Case Studies 1-5 are assumed to occur in the near-term phase, with an estimated cost of \$297 million. In the mid-term phase, Case Study 6-10 would be implemented along with 15 additional current integration opportunities, with a combined projected cost of \$1 billion. In the long-term phase, 10 additional current integration opportunities would be implemented with an estimated cost of \$500 million. Total estimated costs for all phases are \$1.8 billion.

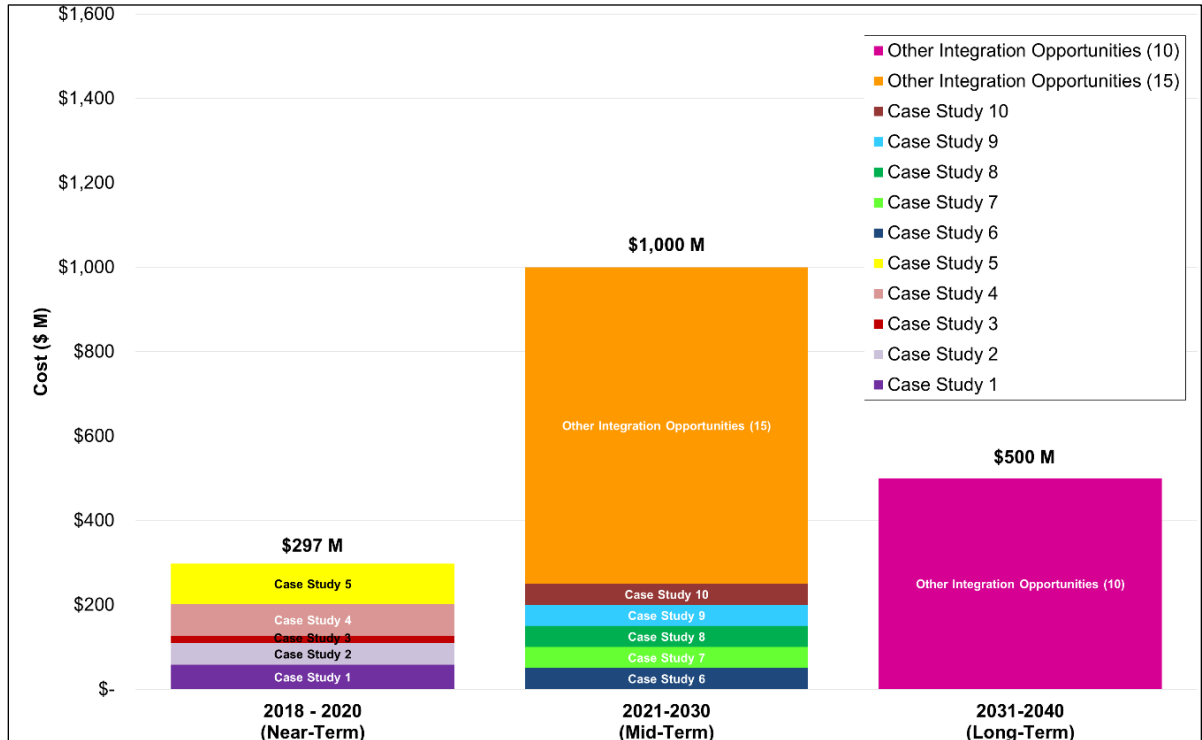

Figure 9.2 Capital Cost Phasing of Current Integration Opportunities

9.4 FUTURE INTEGRATION OPPORTUNITIES

Future integration opportunities include concept ideas that could improve stormwater and receiving water quality, help increase local water supplies and/or help meet stormwater management goals identified in the Sustainable City pLAN. More detailed descriptions of the future integration opportunities are provided in Chapter 6 (and in TM 5.2, see Volume 5). As described in Chapter 6, 27 future integration opportunities were identified as part of this Plan development. Comprehensive evaluation criteria were used to score the future integration opportunities, called "concept options." Through a portfolio evaluation process, the most desired concept options were grouped in a so-called "Preferred Portfolio." This portfolio includes a variety of future strategies, including the top priority (Priority A) water recycling concepts for each of the four WRPs.

The timeline presented in this Chapter only includes the concept options of the Preferred Portfolio with these Priority A projects. As future conditions and triggers may change the most adequate water recycling option for each plant, a trigger-based implementation strategy was developed to guide the City with its decision making regarding alternate concept options, also referred to as Priority B and Priority C concepts. This trigger-based implementation strategy is presented in Chapter 10. The Priority A concept options included in the Preferred Portfolio are summarized in Table 9.2, while the proposed conveyance configurations of each concept option is depicted on Figure 9.3. As shown, Priority A concepts are depicted in orange, Priority B concepts in yellow, Priority C concepts in green, and all other non-prioritized concepts in blue arrows and icons.

Table 9.2 Preferred Portfolio Future Integration Opportunities Summary Report One Water LA 2040 Plan		
Concept Option No.	Concept Options Name	Strategy
5	Dry Weather Low Flow Diversions	Low Flow Diversions
8A	LA River Recharge into LA Forebay	LA River Storage and Use
13	HWRP to Regional System	Potable Reuse
15	DCTWRP to LA Aqueduct Filtration Plant (which requires Concept Options #22)	Potable Reuse with Raw Water Augmentation
17	LAGWRP to Headworks Reservoir	Potable Reuse with Treated Water Augmentation
22	East-West Valley Interceptor Sewer flow management option	Flow Management

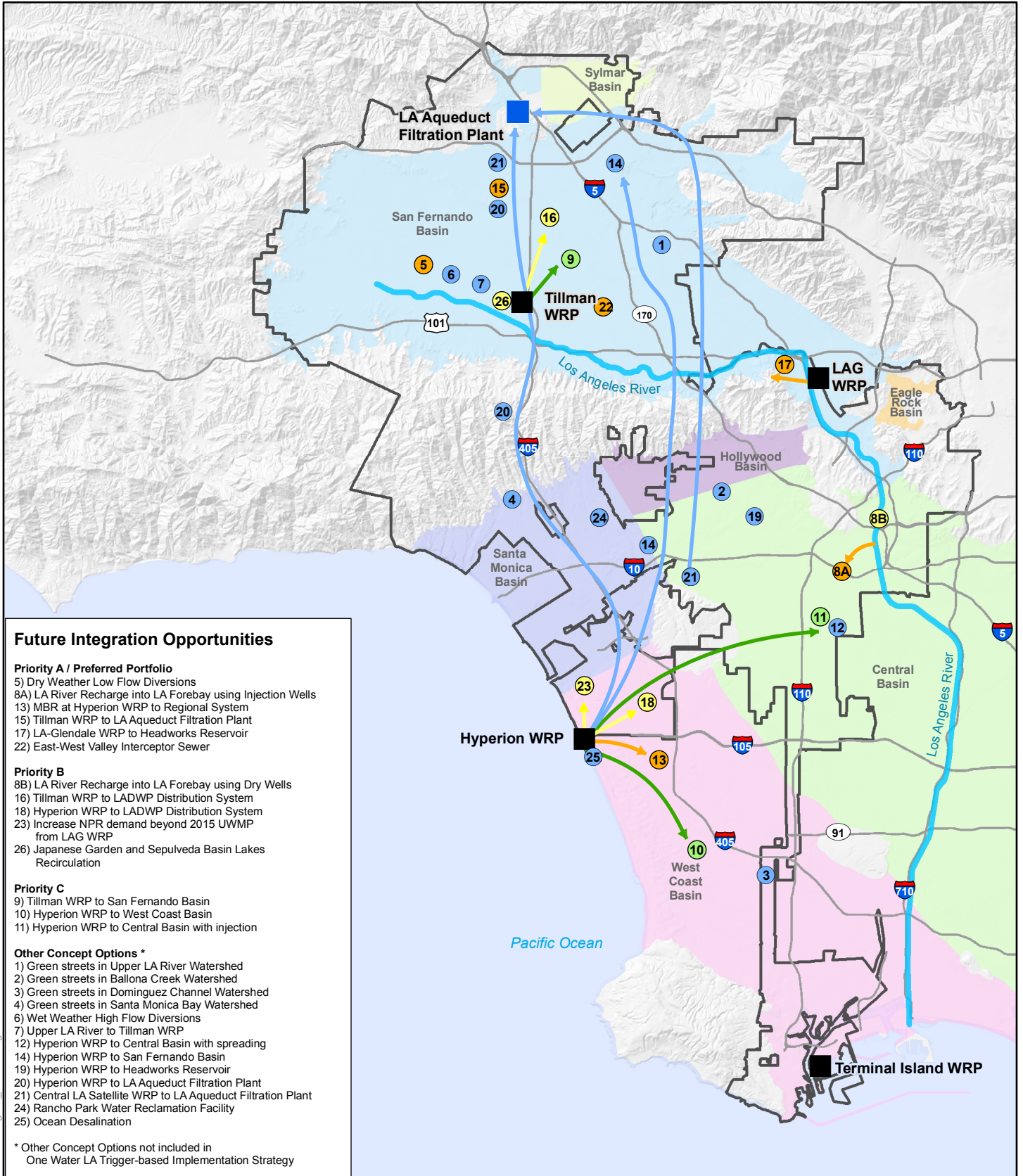

Future Integration Opportunities

- Priority A / Preferred Portfolio**
- 5) Dry Weather Low Flow Diversions
 - 8A) LA River Recharge into LA Forebay using Injection Wells
 - 13) MBR at Hyperion WRP to Regional System
 - 15) Tillman WRP to LA Aqueduct Filtration Plant
 - 17) LA-Glendale WRP to Headworks Reservoir
 - 22) East-West Valley Interceptor Sewer
- Priority B**
- 8B) LA River Recharge into LA Forebay using Dry Wells
 - 16) Tillman WRP to LADWP Distribution System
 - 18) Hyperion WRP to LADWP Distribution System
 - 23) Increase NPR demand beyond 2015 UWMP from LAG WRP
 - 26) Japanese Garden and Sepulveda Basin Lakes Recirculation
- Priority C**
- 9) Tillman WRP to San Fernando Basin
 - 10) Hyperion WRP to West Coast Basin
 - 11) Hyperion WRP to Central Basin with injection

- Other Concept Options ***
- 1) Green streets in Upper LA River Watershed
 - 2) Green streets in Ballona Creek Watershed
 - 3) Green streets in Dominguez Channel Watershed
 - 4) Green streets in Santa Monica Bay Watershed
 - 6) Wet Weather High Flow Diversions
 - 7) Upper LA River to Tillman WRP
 - 12) Hyperion WRP to Central Basin with spreading
 - 14) Hyperion WRP to San Fernando Basin
 - 19) Hyperion WRP to Headworks Reservoir
 - 20) Hyperion WRP to LA Aqueduct Filtration Plant
 - 21) Central LA Satellite WRP to LA Aqueduct Filtration Plant
 - 24) Rancho Park Water Reclamation Facility
 - 25) Ocean Desalination

* Other Concept Options not included in One Water LA Trigger-based Implementation Strategy

Legend

	Existing Water Reclamation Plant (WRP)		City of Los Angeles
	Existing Water Filtration Plant		Groundwater Basin Source: LACDPW

Future Integration Opportunity Project Location

	Priority A / Preferred Portfolio		Priority B
	Priority C		Other Concept Options

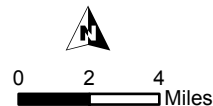

Figure 9.3
Location of Future Integration Opportunities
 One Water LA 2040 Plan Summary Report

Hillshade Source: CalAtlas
<http://www.atlas.ca.gov>



9.4.1 Phasing Assumptions

The future integration opportunities concept phasing listed in Table 9.2 was based on the following considerations:

- Concept Option #5 (Dry Weather Low Flow Diversions) is included in the mid-term phase to increase flows to the WRPs for increased water recycling. The City has already implemented multiple low flow diversions (LFD). Additional study is required to prioritize the identified LFD locations and prepare design documents. Hence, this concept is not included in the near-term phase.
- Concept Option #8A (LA River Recharge into LA Forebay using Injection Wells) is included in the mid-term phase. This concept would increase groundwater recharge in the Central Basin for local supply augmentation and is not dependent on the Potable Reuse Regulations. Hence, this concept option is therefore included in the mid-term phase rather than the long-term phase.
- Concept Option #13 (MBR at HWRP to Regional System) is included in the long-term phase. This potable reuse option would require an interagency agreement as well as the construction of an advanced water purification facility and possibly some substantial conveyance infrastructure to a delivery point.

This concept could depend on new potable reuse regulations if the configuration would include either raw or treated water augmentation. Due to the complexities of this concept option and the uncertain timing of the final potable reuse regulations, this concept is included in the long-term phase. If this concept would consist of potable reuse with groundwater augmentation, then this concept could possibly be implemented sooner.

- Concept Option #15 (DCTWRP to LAAFP) is included in the long-term phase. This concept option would require that the potable reuse regulations with raw water augmentation be approved. Additionally, this concept relies upon increased flows to DCTWRP from implementation of flow management strategies and/or increased flows as a result of densification in the San Fernando Valley. Due to the uncertain timing of the final potable reuse regulations, this concept is included in the long-term phase.
- Concept Option #17 (LAGWRP to Headworks Reservoir) is included in the long-term phase. This concept option would require that the potable reuse regulations with treated water augmentation are approved. It is anticipated that this type of potable reuse will be the last augmentation configuration to be approved. Hence, this concept is included in the long-term phase but could also extend beyond 2040.
- Concept Option #22 (East-West Valley Interceptor Sewer) is included in the near-term phase to increase flows to Donald C. Tillman Water Reclamation Plant (DCTWRP) to augment the annual yield of the Groundwater Replenishment Project that is currently in-progress. This concept option may also provide additional recycled water for other future water recycling concept options.

9.4.2 Cost Estimates

A cost summary for future integration opportunities from the recommended Preferred Portfolio is provided in Table 9.3. As shown, the total estimated capital cost of these Priority A concept options is \$2.5 billion. This includes an estimated \$85 million in costs for the near-term phase, \$1,110 million for the mid-term phase, and \$1,440 million for the long-term phase. The cost estimates for the alternate concept options (Priority B and C) are presented in Chapter 10.

Table 9.3 Estimated Cost of Future Integration Opportunities Summary Report One Water LA 2040 Plan				
Concept Option No.⁽⁴⁾	Phase⁽²⁾			
	Near-Term (2018-2020) (\$M)	Mid-Term (2021-2030) (\$M)	Long-Term (2031-2040) (\$M)	Total (2018-2040) (\$M)
Concept Option 5	\$0	\$110	\$0	\$110
Concept Option 8A	\$0	\$980	\$0	\$980
Concept Option 13	\$0	\$0	\$900	\$900
Concept Option 15	\$0	\$0	\$310	\$310
Concept Option 17	\$0	\$0	\$140	\$140
Concept Option 22	\$85	\$0	\$0	\$85
Total	\$85	\$1,090	\$1,350	\$2,525
Notes:				
(1) Cost estimating details for each Concept Option are provided in TM 5.2 (see Volume 5)				
(2) Phasing assumptions were developed for planning purposes only. Actual concept phasing and costs will need to be further developed, monitored, and updated on an as-needed basis.				

The cost distribution of the future integration opportunities included in the Preferred Portfolio is illustrated on the pie chart shown on Figure 9.4.

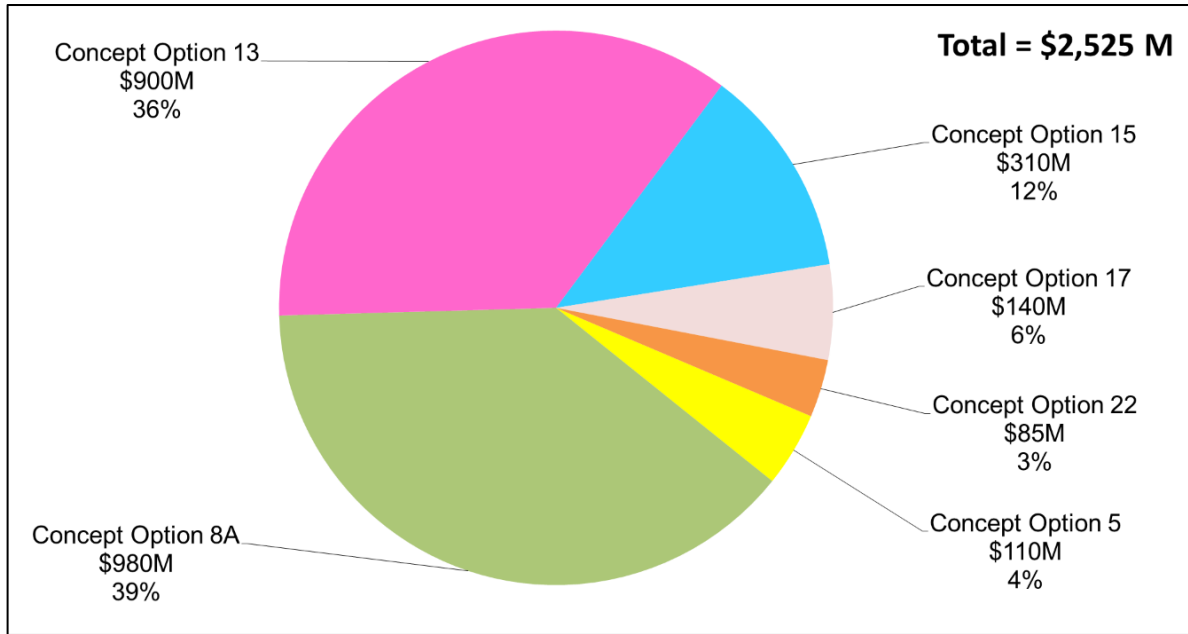

Figure 9.4 Estimated Cost of Future Integration Opportunities

As shown on Figure 9.4, the majority of costs are associated with Concept Option #8A (\$980 million or 39 percent) and Concept Option #13 (\$900 million or 36 percent). The remaining four concept options represent a total cost of \$645 million or 25 percent of the total cost. As shown, the cost contribution of these four concepts ranges from 3 percent to 12 percent of the total costs.

9.4.3 Cost Estimate Summary by Phase

Costs for the future integration opportunities are presented by phase on the bar chart on Figure 9.5. As shown, the cost associated with this category increases over time from \$85 million in the near-term phase to nearly \$1.1 and \$1.4 billion in the mid-term and long-term phases, respectively. Figure 9.5 also graphically presents the assumed phasing of the different concept options. As shown, it is assumed that Concept Option #22 would occur in the near-term phase, while Concept Options #5 and #8A would be implemented in the mid-term phase with a combined projected cost of \$1,090 million. In the long-term phase, it is assumed that Concept Options #13, #15, and #17 would be implemented with an estimated cost of \$1,350 million.

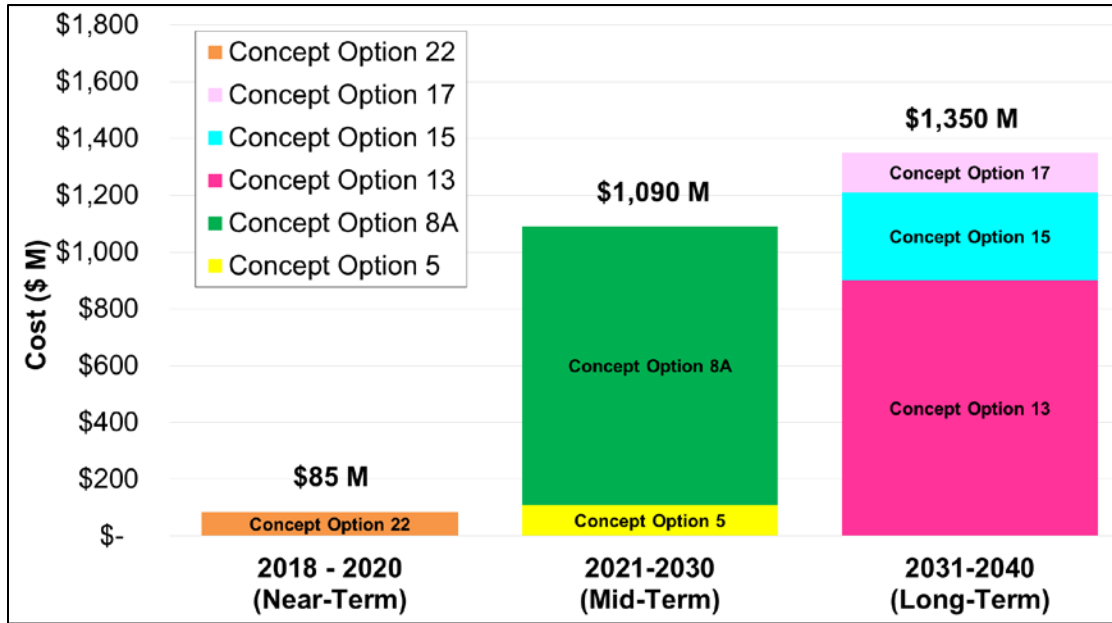

Figure 9.5 Estimated Capital Cost Phasing of Future Integration Opportunities

9.5 WASTEWATER PROJECTS

Wastewater projects consist of improvement projects for the City's four WRPs and the wastewater collection systems in order to address existing deficiencies and meet future system needs. The wastewater projects are described in more detail in the WWFP (see Chapter 7 and Volume 2). The listing of projects in the Wastewater Facilities Plan includes already-approved projects from LASAN's Wastewater Capital Improvement Plan (WCIP), as well as new recommended projects that resulted from the One Water LA process. Wastewater projects can be differentiated in two different ways:

- By each of the four WRPs and collection system
- By project category, namely:
 - Capital Projects from the City's WCIP
 - Replacement and Rehabilitation (R&R) projects from WCIP
 - Climate Resiliency Projects
 - Projected Capital Projects
 - Projected R&R Projects

It should be noted that the CIP of the WWFP not only includes the project categories listed above, but also includes the some of the In-Progress projects, one of the Current Integration Opportunities, and many of the Future Concept Options. To avoid double counting, the cost of these projects are not included in this section and the total wastewater CIP amounts presented in this Chapter and the WWFP therefore differ.

There are too many individual project recommendations included in the WWFP (nearly 300) to list in this Chapter. However, a complete project listing can be found in Appendix H of the WWFP (see Volume 2). A summary of the number of projects by each of these categories is shown by WRP on Figure 9.6.

Donald C. Tillman WRP

WWFP CIP

- 23 Capital Projects from WCIP (\$155 M)
- 8 R&R Projects from WCIP (\$10 M)
- 2 Climate Resiliency Projects (\$12 M)
- Projected Capital Projects (\$240 M)
- Projected R&R Projects (\$200 M)

Total without Future Concepts = \$618 M*

Future Concepts (Priority A,B, C and Other)

- 7) Upper Los Angeles River to DCTWRP
- 9) DCTWRP to San Fernando Basin Injection Wells
- 15) DCTWRP to Los Angeles Aqueduct Filtration Plant**
- 16) DCTWRP to LADWP Distribution System
- 22) East-West Valley Interceptor Sewer**
- 26) Japanese Garden and Sepulveda Basin Lakes Recirculation

LA-Glendale WRP

WWFP CIP

- 2 Capital Projects from WCIP (\$18 M)
- 18 R&R Projects from WCIP (\$56 M)
- 3 Climate Resiliency Projects (\$14 M)
- Projected Capital Projects (\$119 M)
- Projected R&R Projects (\$20 M)

Total without Future Concepts = \$227 M*

Future Concepts (Priority A,B, C and Other)

- 17) LAGWRP to Headworks Reservoir**
- 23) Increase Recycled Water Demand beyond 2015 UWMP

Collection System

WWFP CIP

- 15 Capital Projects from WCIP (\$258 M)
- 105 R&R Projects from WCIP (\$468 M)
- 29 Climate Resiliency Projects (\$15 M)

Total = \$741 M*

Hyperion WRP

WWFP CIP

- 7 Capital Projects from WCIP (\$51 M)
- 37 R&R Projects from WCIP (\$170 M)
- 1 Climate Resiliency Project (\$1 M)
- Projected Capital Projects (\$920 M)
- Projected R&R Projects (\$360 M)

Total without Future Concepts = \$1,501 M*

Future Concepts (Priority A,B,C and Other)

- 10) HWRP to West Coast Basin Injection Wells
- 11) HWRP to Central Basin Injection Wells
- 13) MBR at HWRP to Regional System**
- 14) HWRP to San Fernando Basin Injection Wells
- 18) HWRP to LADWP Distribution System
- 19) HWRP to Headworks Reservoir
- 20) HWRP to Los Angeles Aqueduct Filtration Plant

Terminal Island WRP

WWFP CIP

- 10 Capital Projects from WCIP (\$35 M)
- 18 R&R Projects from WCIP (\$76 M)
- 2 Climate Resiliency Projects (\$14 M)
- Projected Capital Projects (\$140 M)
- Projected R&R Projects (\$38 M)

Total without Future Concepts = \$303 M*

*** Any differences in sum or in comparison to Volume 2 are due to rounding**

Legend

Existing Water Reclamation Plant (WRP)

City of Los Angeles

Sewersheds

Bold Text = Priority A / Preferred Portfolio
See Appendix C for detailed priority listing

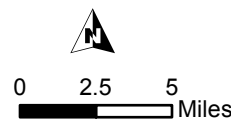

Hillshade Source: CalAtlas
<http://www.atlas.ca.gov>

Figure 9.6
Summary of Wastewater Projects by WRP
One Water LA 2040 Plan
Summary Report

9.5.1 Phasing Assumptions

The specific phasing assumptions associated with wastewater projects to group the recommendations into the near-term, mid-term, and long-term phases is described in more detail in the WWFP (see Volume 2). In general, wastewater projects are phased based on the following considerations:

- Projects that address existing system deficiencies are included in the near-term and mid-term phases based on the project urgency and input from plant staff;
- Projects that address future system needs are included in the mid-term and long-term phases based on the anticipated timing of project triggers, such as, but not limited to, future flows and new regulations.
- Projects that address aging infrastructure replacement needs are included in all three phases, but primarily in the long-term phase based on the anticipated timing of the end of useful life of the various assets included in this category.

9.5.2 Cost Estimates

A cost summary by treatment plant and collection system is provided in Table 9.4. As shown, the total estimated capital cost of the wastewater and water recycling projects is \$3,390 million. This includes an estimated \$1,030 million in costs for the near-term phase, \$423 million for the mid-term phase, and \$1,937 million for the long-term phase. Chapter 7 provides cost estimating assumptions and details used.

Table 9.4 Estimated Cost of Wastewater Projects by Treatment Plant Summary Report One Water LA 2040 Plan				
Project Category	Project Phase⁽²⁾			
	Near-Term (2018-2020) (\$M)	Mid-Term (2021-2030) (\$M)	Long-Term (2031-2040) (\$M)	Total (2018-2040) (\$M)
Collection System	\$641	\$78	\$22	\$741
DCTWRP	\$146	\$121	\$350	\$618
LAGWRP	\$72	\$75	\$80	\$227
HWRP	\$106	\$116	\$1,280	\$1,501
TIWRP	\$65	\$33	\$204	\$303
Total	\$1,030	\$423	\$1,937	\$3,390
Notes:				
(1) Cost estimates obtained from Wastewater Facilities Plan (see Volume 2). To avoid double counting this table only presents wastewater CIP projects for the 4 WRPS and the collection system, while the WWFP also includes in-progress projects, one current integration opportunities, and many of the future concept options that pertain to the WRPs.				
(2) Project phasing assumptions made for planning purposes only. Actual project phasing and costs will need to be further developed, monitored, and updated on an as-needed basis.				

The cost distribution of wastewater projects by treatment plant is illustrated on the pie chart shown on Figure 9.7.

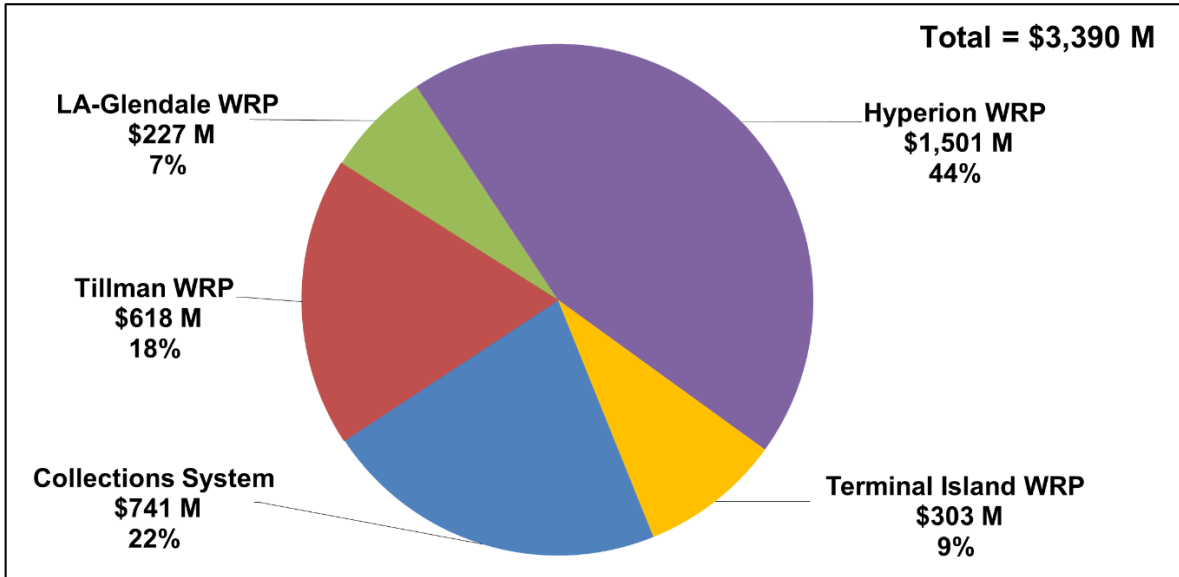

Figure 9.7 Estimated Cost of Wastewater Projects by Treatment Plant

A cost summary by project category is provided in Table 9.5. As shown, these costs match costs by phase shown in Table 9.4, but broken down in different categories. The total estimated cost of \$3,390 million, includes \$518 million for capital projects from WCIP, \$1,519 million for projected capital improvement projects, \$56 million for climate resiliency improvements, \$779 million for replacement and rehabilitation (R&R) projects from the WCIP, and \$518 million for projected R&R projects. Chapter 7 provides cost estimating assumptions and details used.

Project Category	Project Phase ⁽²⁾			
	Near-Term (2018-2020) (\$M)	Mid-Term (2021-2030) (\$M)	Long-Term (2031-2040) (\$M)	Total (2018-2040) (\$M)
Capital Projects from WCIP	\$416	\$92	\$10	\$518
R&R Projects from WCIP	\$585	\$171	\$23	\$779
Projected Capital Projects	\$0	\$159	\$1,360	\$1,519
Climate Resiliency Projects	\$30	\$2	\$25	\$56
Projected R&R Projects	\$0	\$0	\$518	\$518
Total	\$1,030	\$423	\$1,937	\$3,390

Notes:
 (1) Cost estimates obtained from Wastewater Facilities Plan (see Volume 2).
 (2) Project phasing assumptions made for planning purposes only. Actual project phasing and costs will need to be further developed, monitored, and updated on an as-needed basis.

The cost distribution of wastewater projects by project type is illustrated on the pie chart shown on Figure 9.8. As shown, the capital projects identified in the WCIP and the projected capital project collectively account for 60 percent of the entire wastewater CIP with a total of just over \$2 billion (\$2,037 million). The R&R project from the WCIP and projected through year 2040 account for the majority of the remaining cost with \$1,297 million (38 percent). The remaining 2 percent of the total costs are associated with climate resiliency projects. The total wastewater CIP cost is estimated to be \$3.4 billion.

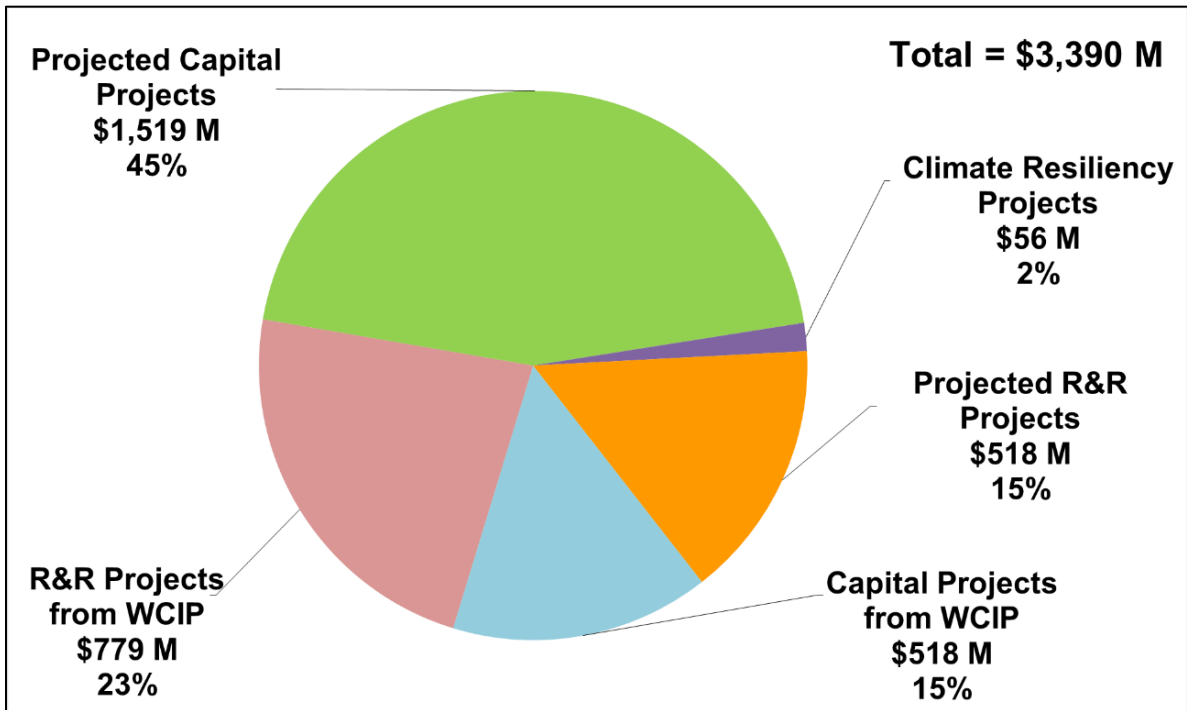

Figure 9.8 Estimated Cost of Wastewater Projects by Project Category

9.5.3 Cost Summary by Phase

Costs for wastewater projects by treatment plant/collection systems, divided into implementation phase, are presented on the bar chart on Figure 9.9. These include capital costs for the near-term, mid-term, and long-term phases. As shown, the projects that are phased in the near-term phase have a combined estimated cost of \$1,030 million. In the mid-term phase, projects would have a combined projected cost of \$423 million, while the total cost of projects phased in the long-term phase is estimated to be approximately \$1,937 million.

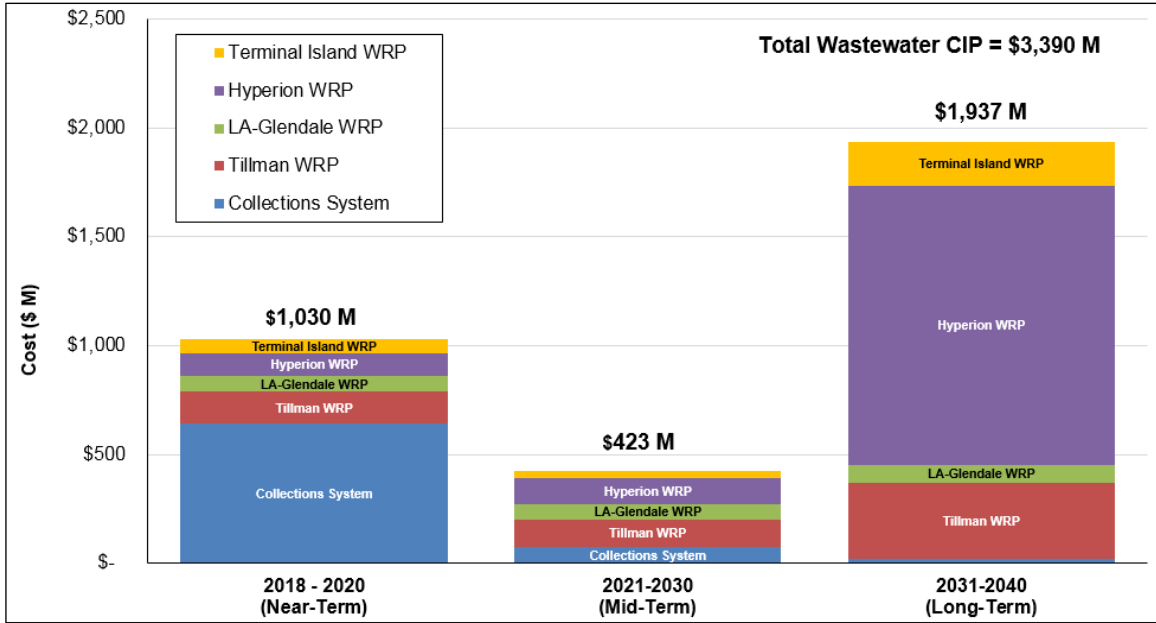

Figure 9.9 Capital Cost Phasing of Wastewater Projects by Treatment Plant

These same costs are presented by project type and by implementation phase in the bar chart provided on Figure 9.10. As shown, the majority of costs are phased in the long-term.

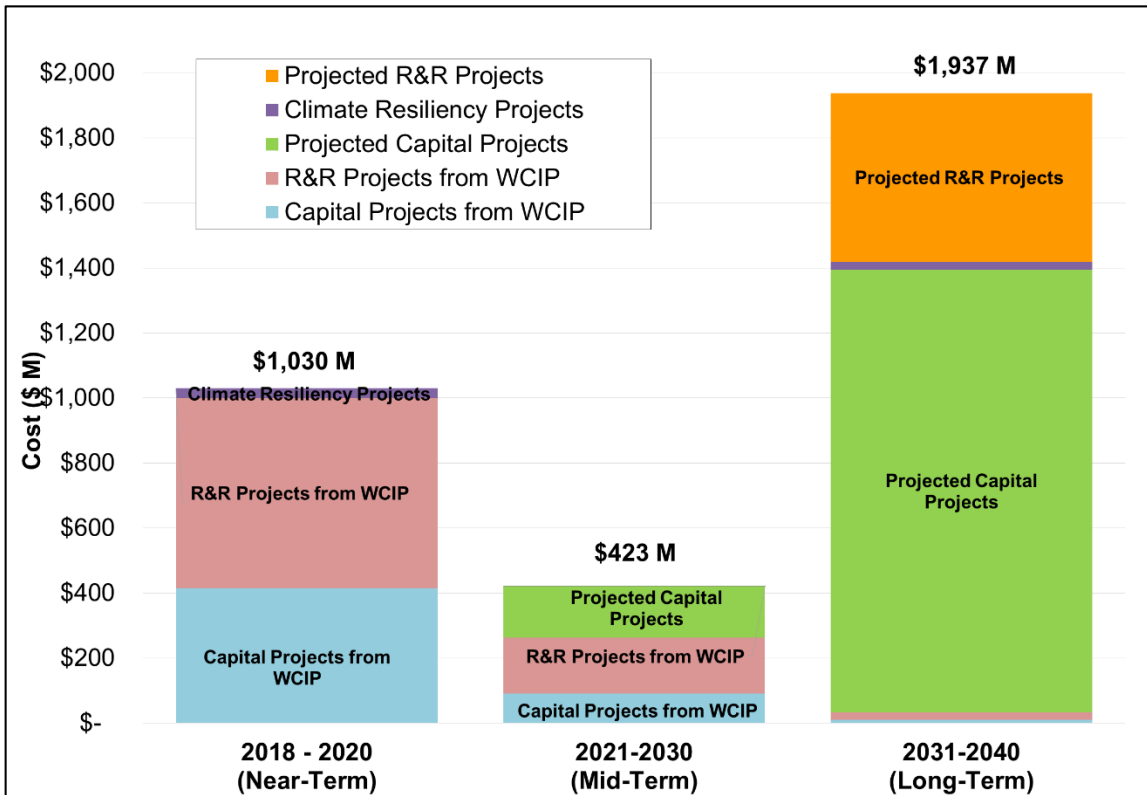

Figure 9.10 Capital Cost Phasing of Wastewater Projects by Project Type

As shown on Figure 9.10, the largest cost category of the entire wastewater CIP is the "Projected Capital Projects", which are phased in the mid-term and long-term planning periods only. These projects still need to be developed in more detail in the future. The Capital and R&R projects already identified in the WCIP are all phased in the near-term and mid-term phases.

9.6 STORMWATER PROJECTS AND PROGRAMS

This category includes stormwater projects and programs that would help meet water quality regulations, address flooding risks, and/or provide water supply benefits by recharging stormwater in underlying aquifers. These stormwater projects and programs are described in the Stormwater and Urban Runoff Facilities Plan (see Chapter 8 and Volume 3). Stormwater projects can be categorized in two different ways:

- By watershed:
 - Upper LA River
 - Ballona Creek
 - Dominguez Channel
 - Santa Monica Bay; and
 - Marina Del Rey (Due to its size and location, the Marina Del Rey watershed has been combined with the Santa Monica Bay Watershed in this Plan)
- By project type:
 - Regional Grey Infrastructure
 - Regional Green Infrastructure
 - Distributed Green Infrastructure

There are too many individual project recommendations included in the SWFP (nearly 1,142 are located within the City, with a total of 1,201 including regional projects) to list in this Chapter. However, a complete project listing can be found in Appendix D as well as Appendix F of the Stormwater and Urban Runoff Facilities Plan (see Volume 3). A summary of the number of projects by each of these categories is shown by watershed on Figure 9.11. Note, the total quantity and estimated cost of stormwater projects summarized in this Chapter is based on the 1,142 projects within the City only.

Upper Los Angeles River Watershed

- 434 Distributed Green Infrastructure projects (\$1007 M)
- 93 Regional Green Infrastructure projects (\$1894 M)
- 301 Regional Gray Infrastructure projects (\$490 M)
- 69.8 miles of Green Streets
- Total = \$3,391 M**

Ballona Creek Watershed

- 113 Distributed Green Infrastructure projects (\$1001 M)
- 83 Regional Green Infrastructure projects (\$326 M)
- 5 Regional Gray Infrastructure projects (\$43 M)
- 61.3 miles of Green Streets
- Total = \$1,370 M**

Santa Monica Bay - Marina Del Rey Watershed

- 41 Distributed Green Infrastructure projects (\$383 M)
- 15 Regional Green Infrastructure projects (\$124 M)
- 8 Regional Gray Infrastructure projects (\$23 M)
- 14.4 miles of Green Streets
- Total = \$530 M**

Dominguez Channel and LA Harbor Watershed

- 31 Distributed Green Infrastructure projects (\$166 M)
- 6 Regional Green Infrastructure projects (\$108 M)
- 12 Regional Gray Infrastructure projects (\$26 M)
- 8.9 miles of Green Streets
- Total = \$300 M**

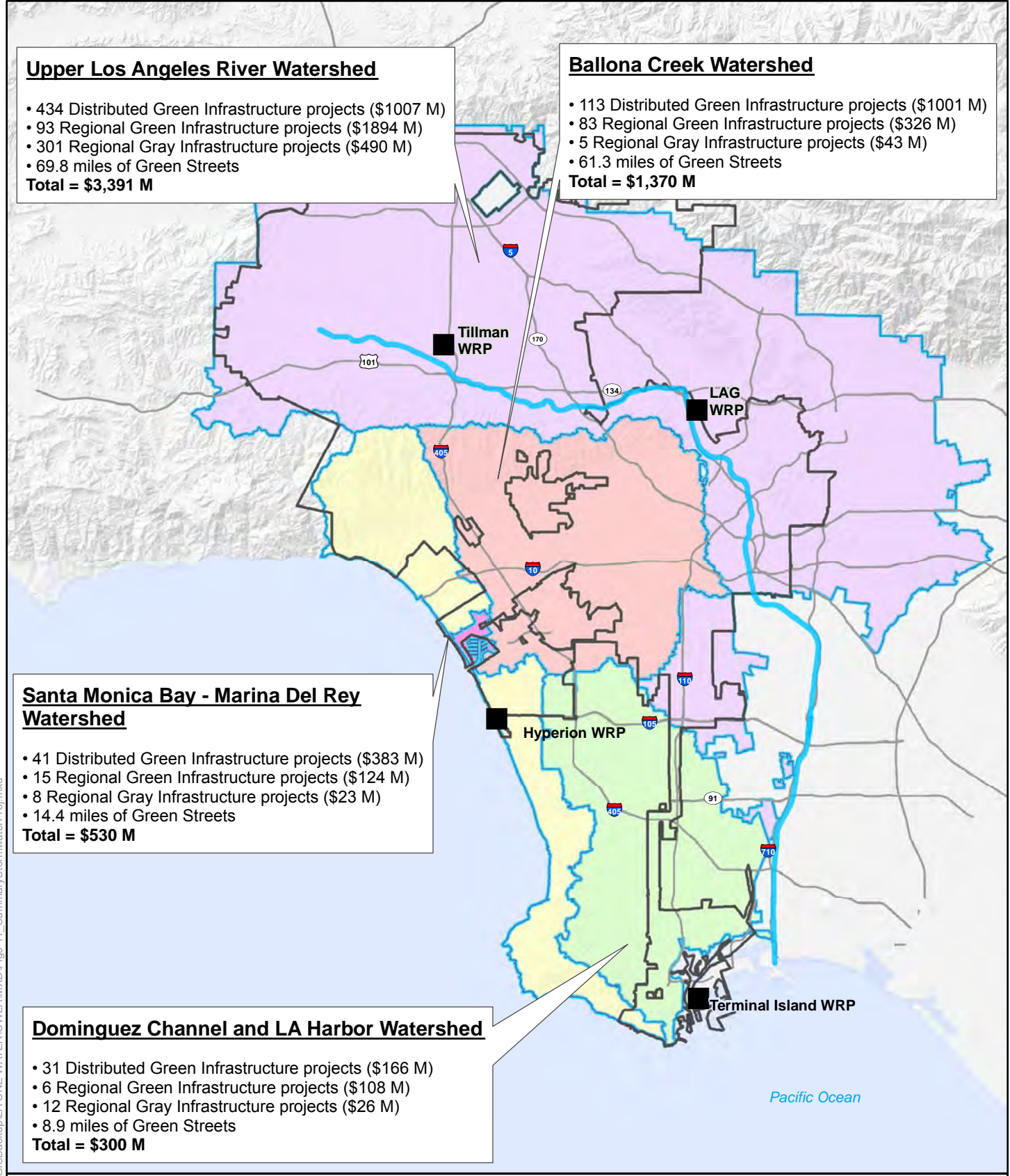

Legend

- Existing Water Reclamation Plant (WRP)
- City of Los Angeles
- Watershed Boundary
- Marina Del Rey
- Los Angeles River
- Ballona Creek
- Santa Monica Bay
- Dominguez Channel and LA Harbor

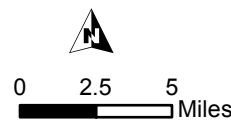

Hillshade Source: CalAtlas
<http://www.atlas.ca.gov>

Figure 9.11
Summary of Stormwater
Projects by Watershed
 One Water LA 2040 Plan
 Summary Report

9.6.1 Phasing Assumptions

Stormwater infrastructure projects are typically targeted to address either flood risk mitigation, water quality improvement, or water supply augmentation. It is the intent of this Plan to incorporate all three benefits into the "three-legged stool" integrated approach to stormwater and urban runoff infrastructure planning. This new project prioritization approach is summarized in Chapter 8, while a detailed description of this approach is included in the Stormwater Facilities Plan (see Volume 3).

In general, stormwater projects are phased based on the following considerations:

- Stormwater projects driven by regulations, such as TMDLs and/or 303(d) listings, are phased prior to the compliance deadline (See Figure 9.12). This results in focused effort by watershed described and illustrated as follows:
 - Stormwater projects that provide water quality benefits in the Ballona Creek Watershed are included in the near-term phase to meet the Metals and Bacterial TMDL requirements by 2021.
 - Stormwater projects that provide water quality benefits in the Santa Monica Bay and Marina Del Rey Watersheds are included in the near-term phase to meet the Bacteria TMDL requirements by 2021.
 - Stormwater projects that provide water quality benefits in the Dominguez Channel Watershed are included in the near-term and mid-term phases to meet the Toxic Pollutant TMDL requirements by 2026 (50 percent) and 2032 (100 percent). Hence a small portion of the project can still be implemented in the early part of the long-term phase.

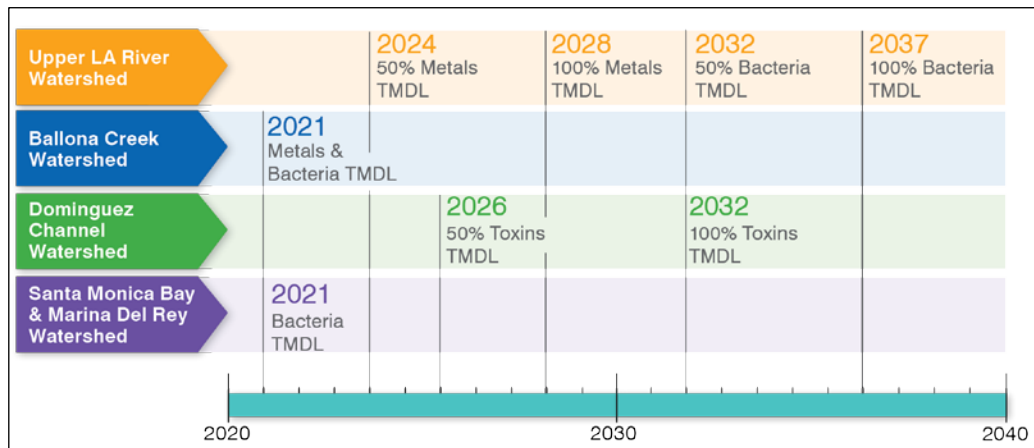

Figure 9.12 TMDL Compliance Deadlines by Watershed

- Stormwater projects that provide water quality benefits in the Upper LA River Watershed are included in all three phases to meet the Metals TMDL requirements by 2024 (50 percent) and 2028 (100 percent), as well as the Bacteria TMDL requirements by 2032 (50 percent) and 2037 (100 percent).

- Stormwater projects that (also) provide water supply benefits are prioritized in the SIP based on the estimated benefit of a project to:
 - reduce potable water demand through conservation measures;
 - contribute to groundwater recharge of potable water aquifers;
 - supply non-potable demands;
 - capture and use stormwater/dry weather runoff to offset potable water demand.
- Stormwater projects that (also) provide flood risk mitigation benefits are prioritized in the SIP based on project characteristics such as:
 - the type of jurisdictional asset (Federal, County, or City)
 - whether the project is located within the 50-year floodplain
 - whether the project is located within the FEMA flood zone

9.6.2 Cost Estimates

A cost summary of stormwater projects and programs by watershed is provided in Table 9.6. As shown, the total estimated cost of stormwater projects is \$5.6 billion. This includes an estimated \$2,538 million in costs for the near-term phase, \$761 million for the mid-term phase, and \$2,292 million for the long-term phase. Chapter 8 provides cost estimating assumptions and details used. The costs presented in Table 9.6 summarize the cost estimates presented in the Stormwater and Urban Runoff Facilities Plan (SWFP, see Volume 3). It should be noted that these costs differ from the cost estimates from the Enhanced Watershed Management Plans (EWMPs), as the SWFP includes a compilation of projects from the EWMPs, Stormwater Capture Master Plan (SCMP), and other planned stormwater management projects from LASAN and LADWP.

Table 9.6 Cost Summary of Stormwater Projects and Programs by Watershed Summary Report One Water LA 2040 Plan				
Project Description	Project Phase⁽²⁾			
	Near-Term (2018-2020) (\$M)	Mid-Term (2021-2030) (\$M)	Long-Term (2031-2040) (\$M)	Total (2018-2040) (\$M)
Ballona Creek Watershed	\$1,343	\$0	\$27	\$1,370
Dominguez Channel Watershed	\$163	\$22	\$114	\$300
Santa Monica/Marina Del Rey Watershed	\$518	\$0	\$13	\$530
Upper LA River Watershed	\$513	\$739	\$2,138	\$3,391
Total	\$2,538	\$761	\$2,292	\$5,591
Notes:				
(1) Cost estimates obtained from Stormwater and Urban Runoff Facilities Plan (see Volume 3).				
(2) Project phasing assumptions made for planning purposes only. Actual project phasing and costs will need to be further developed, monitored, and updated on an as-need basis.				

The cost distribution of stormwater projects and programs by watershed is illustrated on the pie chart shown on Figure 9.13. As shown, the majority of costs are associated with the Upper LA River Watershed (\$3.4 billion or 61 percent), followed by the Ballona Creek Watershed (\$1.4 billion or 25 percent), the Santa Monica Bay/Marina Del Rey Watershed (\$530 million or 9 percent), and the Dominguez Channel Watershed (\$300 million or 5 percent).

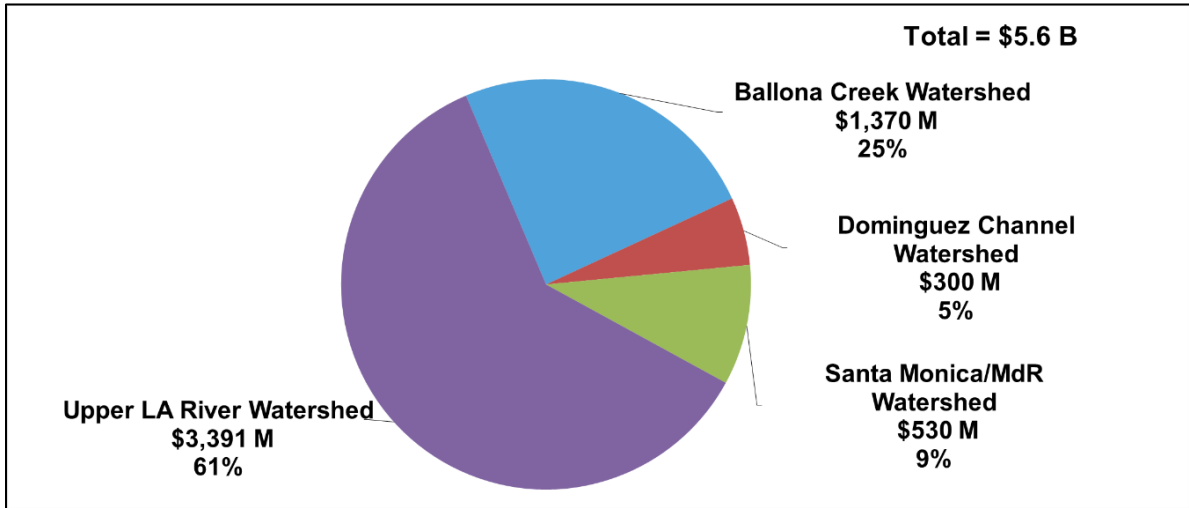

Figure 9.13 Cost Distribution of Stormwater Projects and Programs by Watershed

A cost summary by stormwater project type is provided in Table 9.7. As shown, these costs match costs by phase shown in Table 9.6, but broken down in different categories. The total estimated cost of \$5.6 billion, and includes \$2.6 billion of distributed green infrastructure projects, \$2.5 billion of regional green infrastructure, and \$582 million of regional grey infrastructure projects. It should be noted that this does not include the cost of LA County's stormwater projects. Chapter 8 provides cost estimating assumptions and details used.

Project Description	Project Phase ⁽²⁾			
	Near-Term (2018-2020) (\$M)	Mid-Term (2021-2030) (\$M)	Long-Term (2031-2040) (\$M)	Total (2018-2040) (\$M)
Regional Grey	\$106	\$0	\$476	\$582
Regional Green	\$739	\$383	\$1,329	\$2,451
Distributed Green	\$1,693	\$378	\$487	\$2,558
Total	\$2,538	\$761	\$2,292	\$5,591

Notes:

(1) Cost estimates obtained from Stormwater and Urban Runoff Facilities Plan (see Volume 3).

(2) Project phasing assumptions made for planning purposes only. Actual project phasing and costs will need to be further developed, monitored, and updated on an as-need basis.

The cost distribution of stormwater projects and programs by project type is illustrated on the pie chart shown on Figure 9.14. As shown, the majority of costs are associated with distributed green infrastructure (\$2.6 billion or 46 percent), while the remaining 56 percent is divided between regional green infrastructure (\$2.5 billion) and regional grey infrastructure (\$582 million).

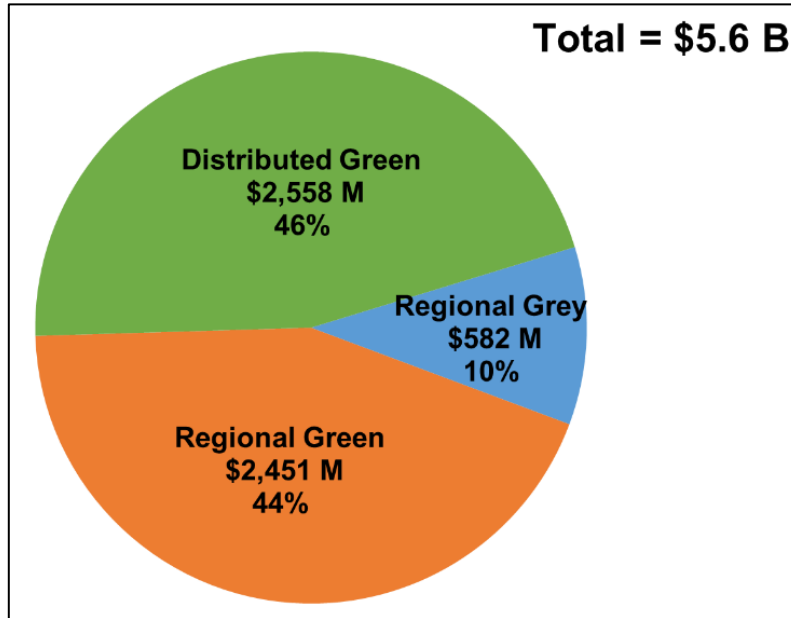

Figure 9.14 Cost Distribution of Stormwater Projects by Project Type

9.6.3 Cost Summary by Phase

Costs for stormwater projects and programs by watershed by implementation phase are presented on the bar chart on Figure 9.15. These include capital costs for the near-term, mid-term, and long-term phases. As shown, projects would occur in all watersheds, with the majority of projects in the Upper LA River Watershed, followed by the Ballona Creek Watershed. The total project costs allocated in the near-term and long-term phases are fairly similar. However the long-term phase is much longer (10 years versus 3 years). Therefore, the stormwater improvement program is heavily front loaded due to the rapidly approaching TMDL compliance deadlines. As shown, the mid-term and long-term phases primarily consist of projects in the Upper LA Watershed, which also covers the largest area of the City.

Estimated costs for stormwater projects and programs by project type by implementation phase are presented on the bar chart on Figure 9.16, which match the cost distribution by phase shown on Figure 9.15. As shown, the distributed green infrastructure not only contributes to the highest total cost, but also represents the majority of the cost by phase. Another observation is that regional grey infrastructure projects are only phased in the near-term and long-term phases.

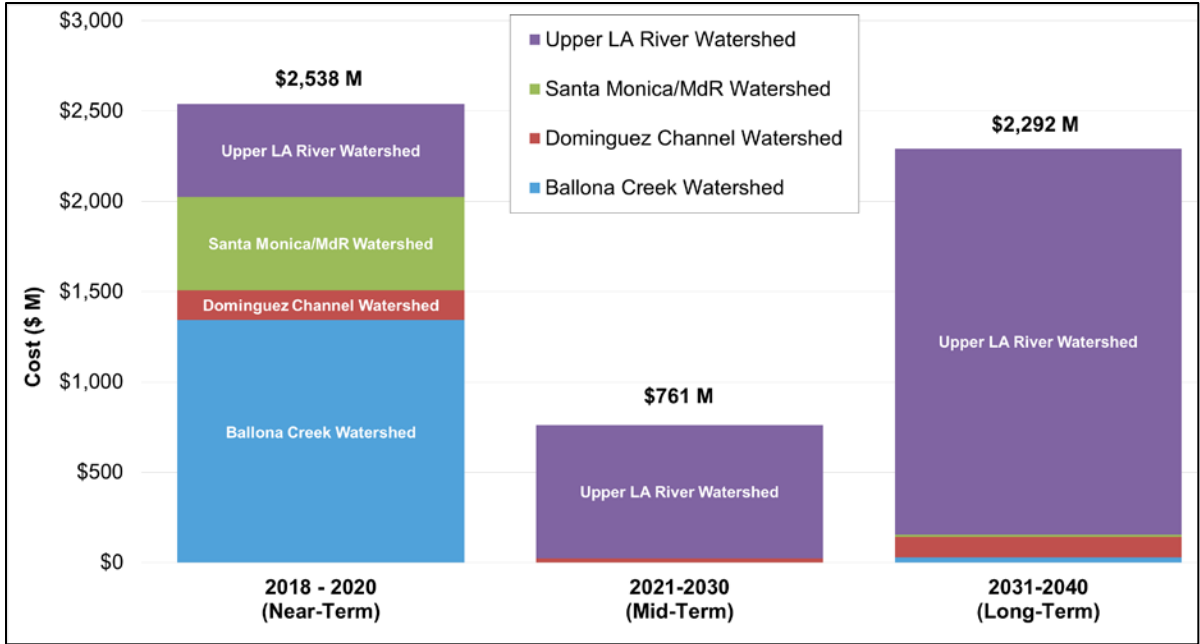

Figure 9.15 Estimated Capital Cost Phasing of Stormwater Projects by Watershed

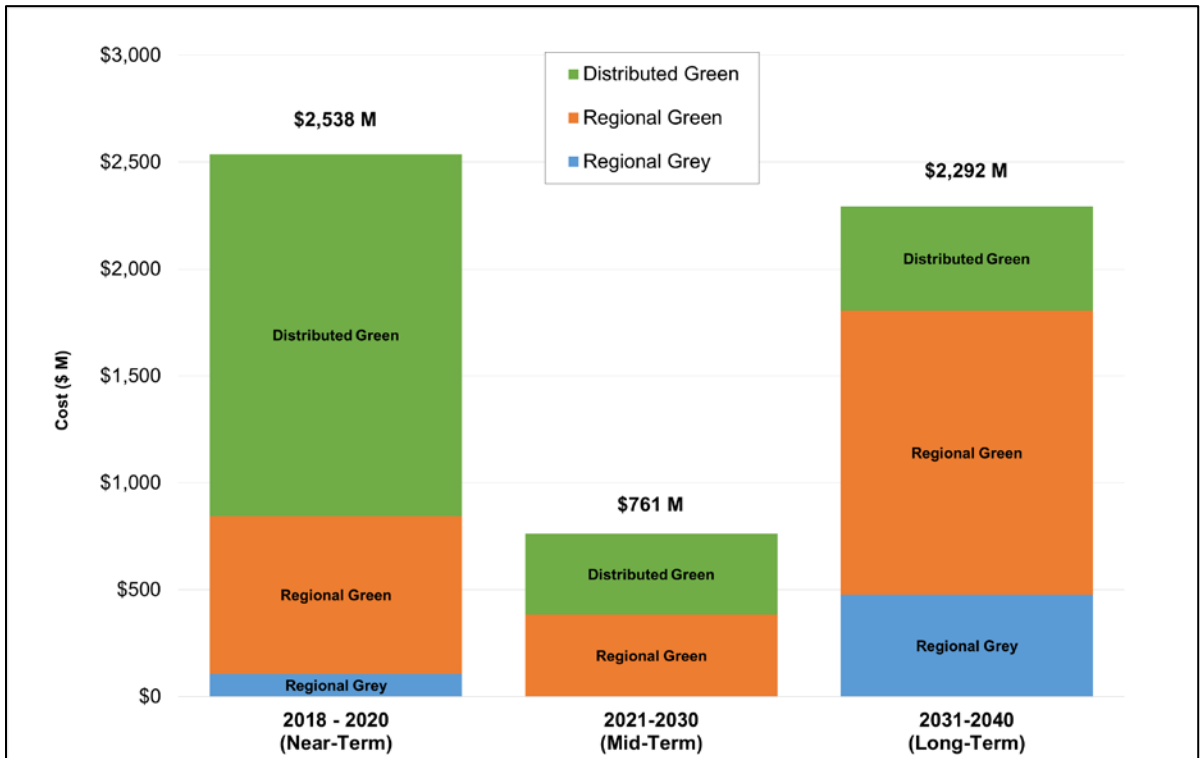

Figure 9.16 Estimated Capital Cost Phasing of Stormwater Projects by Project Type

A summary of the phasing of stormwater projects by watershed and project type along with the TMDL compliance years is presented on Figure 9.17.

9.7 POLICIES AND PROGRAMS

The One Water LA 2040 plan policy development approach built upon the experience gained, and lessons learned during the Water IRP planning effort and One Water LA Phase 1. The City's IRP presented 25 Go policies, and the final status of each is provided in TM 13.1 Appendix A (see Volume 7).

During One Water LA Phase 1, the Steering Committee, comprised of City departments and Regional Agencies, requested policies that would facilitate better communication between departments and agencies and advance One Water LA objectives more effectively. In addition, the "quick-fix" policies align with One Water LA's vision of: smarter land use practices, healthier watersheds, greater reliability of our water and wastewater systems, increased efficiency and operation of utilities, enhanced livable communities, climate change resiliency, and protection of public health. A status report on the One Water LA Phase 1 "Quick-fix" policies is provided in Section 9.7.1.

One Water LA Phase 2 expanded the policy and program development process to include ideas and suggestions from both the Steering Committee and Stakeholders representing a wide variety of interests and perspectives including non-profits, the business community, commercial and industrial interests, and neighborhood council representatives. Policy ideas were collected throughout the One Water LA engagement process.

9.7.1 One Water LA Phase 1 Quick-Fixes Overview

In One Water LA Phase 1, City Departments and Regional Agencies were brought together to identify roadblocks to implementing water-related projects and programs and brainstorm on how the City could address challenges, increase efficiencies, and increase opportunities for collaboration. As a result, 47 "Quick-fix" actions and coordination opportunities that each City Department felt they could quickly implement or that Regional Agencies would propose to their senior management were crafted, presented, and confirmed by the Steering Committee.

The 47 Quick-fixes were initially drafted as a result of 27 individual focus meetings with City Departments and Regional Agencies. The purpose of the focus meetings were to:

- Provide a One Water LA 2040 Plan overview.
- Gain an understanding of the water-related projects, policies, or programs of each City Department or Regional Agency.
- Identify potential integration opportunities.

The quick-fixes were prioritized and were presented to the Mayor's Water Cabinet. The Cabinet identified seventeen of the quick-fixes as priorities for near-term implementation. The list and status of quick-fixes is summarized in TM 13.1 (see Volume 7).



Figure 9.17
Recommended Timeline and Cost of
Stormwater Projects and Programs
 One Water LA 2040 Plan
 Summary Report

9.7.2 Phase 2 Policy and Program Development

A series of One Water LA department and agency Focus Meetings, Steering Committee meetings, Stakeholder Workshops, and Stakeholder Special Topic Group Meetings were conducted to solicit ideas for water policies and programs. Existing policy documents and other plans that contained relevant recommended City water policies were also reviewed. As a result, the One Water LA team compiled an initial list of approximately 85 water policy and program ideas. A special Project Ideas Workshop and a policy focused Stakeholder Workshop resulted in additional policies, programs, research ideas, and action items. In total over 200 policy ideas were collected that covered a variety of topics including:

- Integrated Planning and Design
- Stormwater and Urban Runoff Management
- Training and Education
- Streamlining Collaboration and Implementation
- Funding and Partnerships
- Sustainability and Climate Change
- Water Conservation
- Recycled Water
- LA River Revitalization

An overview of the policy development process that took place to determine the final policy recommendations is shown on Figure 9.18, while a detailed description of this development process and the final list of policy ideas are included in TM 13.1 (see Volume 7).

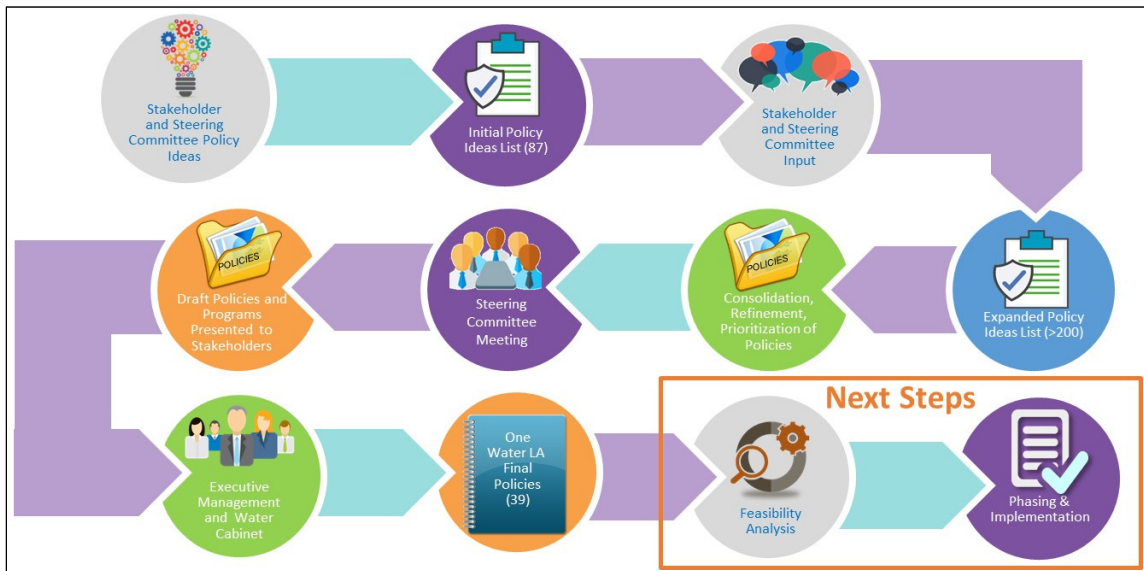

Figure 9.18 One Water LA Policy Development Process

9.7.3 Policy Consolidation and Refinement

Initial Steering Committee meetings and other focus meetings provided an opportunity for policy and program recommendations from the City Departments and Regional Agencies' and helped align the policy and program ideas with each department's vision, mission, and objectives. Similarly, throughout One Water LA's stakeholder engagement process, which included workshops, special topic group meetings, and a project ideas meeting, stakeholders provided their recommendations for policy and programs ideas.

A comprehensive review of notes from these initial Steering and Stakeholder meetings led to a draft policy ideas list. Sources for the initial policy ideas list included the following:

- City Department and Regional Agency Focus Meetings
- Stakeholder Workshops
- Stakeholder Special Topic Group Meetings
- Advisory Group Meetings
- Steering Committee Meetings

Additionally existing Policy Documents were reviewed, including:

- LA Basin Stormwater Conservation Study
- Living Streets
- GRASS (Greenways to Rivers Arterial Stormwater System)
- Mobility Plan 2035
- Stormwater Capture Master Plan
- White Paper - Use of Financial Incentives for Stormwater Fees in Los Angeles County (Coalition of our Water Future)

The compiled list was presented to both the stakeholders and Steering Committee members for input and to solicit any additional ideas. The One Water LA team held a Stakeholder Policy Ideas Workshop, where stakeholders reviewed the draft list received clarification on its content and provided additional ideas. Over 70 new ideas were generated during this workshop. The expanded list consisted of approximately 200 policy ideas with a wide range of topics and varying levels of complexity.

The list was carefully and thoroughly reviewed, ideas were edited for clarity, and redundant ideas were consolidated. Individual ideas that fit into a larger theme were included as considerations to support more general umbrella policy or program concepts.

During the refinement process the ideas were grouped into the following 6 categories:

1. **Policies and Programs** – Concepts and ideas that meet and align with multiple One Water LA Objectives and Guiding Principles and help achieve the Sustainable City pLAn goals.
 - a. Policies – Activities or efforts that can be grouped under a common umbrella idea or theme and can be developed into a policy. Policies may need approval or adoption by policymakers before implementation can proceed.
 - b. Programs – Ideas that consist of several activities and/or efforts that could be developed into an individual or multi-agency program. Programs may need approval or adoption by policymakers before implementation can proceed.
2. **Research Ideas** – Suggestions that are best suited as research projects or ideas that require further research before they could be developed into a policy or program.
3. **Action Items** – Ideas that are not a policy but a simple action the City can pursue.
4. **In-Progress or Accomplished** – Ideas suggested that the City is already pursuing or has accomplished.
5. **Additional Recommendations** – Ideas that are narrow, or not well defined and possibly beyond the scope of One Water LA. These ideas have not been prioritized for implementation at this time. A response to each of the ideas is included.
6. **Beyond Scope** – Ideas that are beyond the scope of the One Water LA planning effort but are documented for potential inclusion in other planning efforts.

The final policy and programs list recommended for further evaluation totaled 39 policies and programs. Figure 9.19 illustrates how the stakeholders were engaged in the policy development process. Figure 9.20 illustrates the City's policy development process. A full list of all of the ideas in each category can be found in TM 13.1 (See Volume 7).



Figure 9.19 Stakeholder Engagement Process



Figure 9.20 City's Policy Development Process

To culminate the City's policy development, a Steering Committee meeting was held in spring 2017 to review and discuss the 21 integration-focused policies and programs. The following guiding questions were used to discuss to discuss policy ideas with the Steering Committee:

- Are any major policy or program ideas that would assist with integration or collaboration opportunities missing?
- Are there any considerations missing from any of the policies?
- Are there other departments that should be listed in lead or support roles?
- Are there any elements you find challenging that we should discuss?
- Is any of the language or intent unclear?

The results of the meeting provided the One Water team with additional direction and input. Individual departments and agencies listed as policy leads or support were contacted to solicit their feedback on language for the remaining policies and programs and their feedback has been included in the final policy list. The complete list of policy ideas and associated research ideas and action items are included in TM 13.1 (see Volume 7).

9.7.4 Policy and Program Classification

The One Water LA objectives, and guiding principles, as well as the policy idea sources were analyzed to support the policy classification process.

The purpose of associating each policy idea with the objectives and guiding principles was to:

1. Align polices with the Objectives and Guiding Principles of One Water LA.
2. Provide guidance on prioritizing polices that meet multiple objectives and were recommended by multiple sources.
3. Provide a reference to connect implementation of specific policies to achieving associated One Water LA objectives and guiding principles.

A policy and program classification exercise was conducted with members of the One Water LA Team and the Mayor's Office. This exercise had two parameters: priority and implementation. The priority was guided by the number of objectives and guiding principles the policy or program could achieve and the variety of sources that recommended the need for the policy or program. The implementation was guided by if the policy or program would be to seemingly easier or more difficult to implement. Figure 9.21 illustrates the matrix tool used to classify the policy and program ideas.

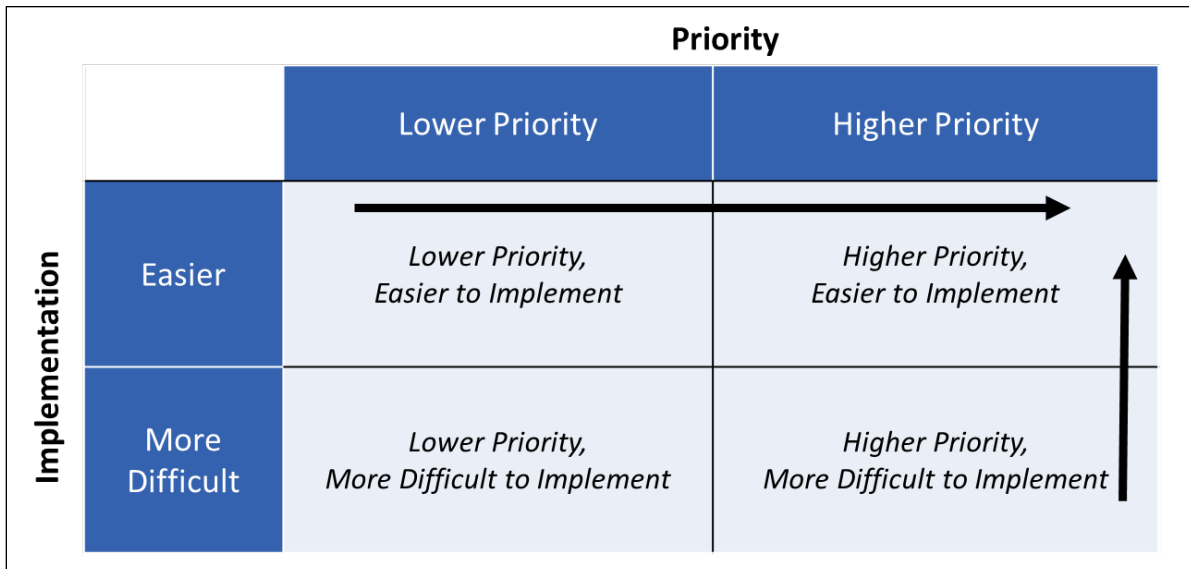

Figure 9.21 Policy and Program Classification Exercise

The results of the policy and program classification exercise completed by the One Water LA team are shown on Figure 9.22.

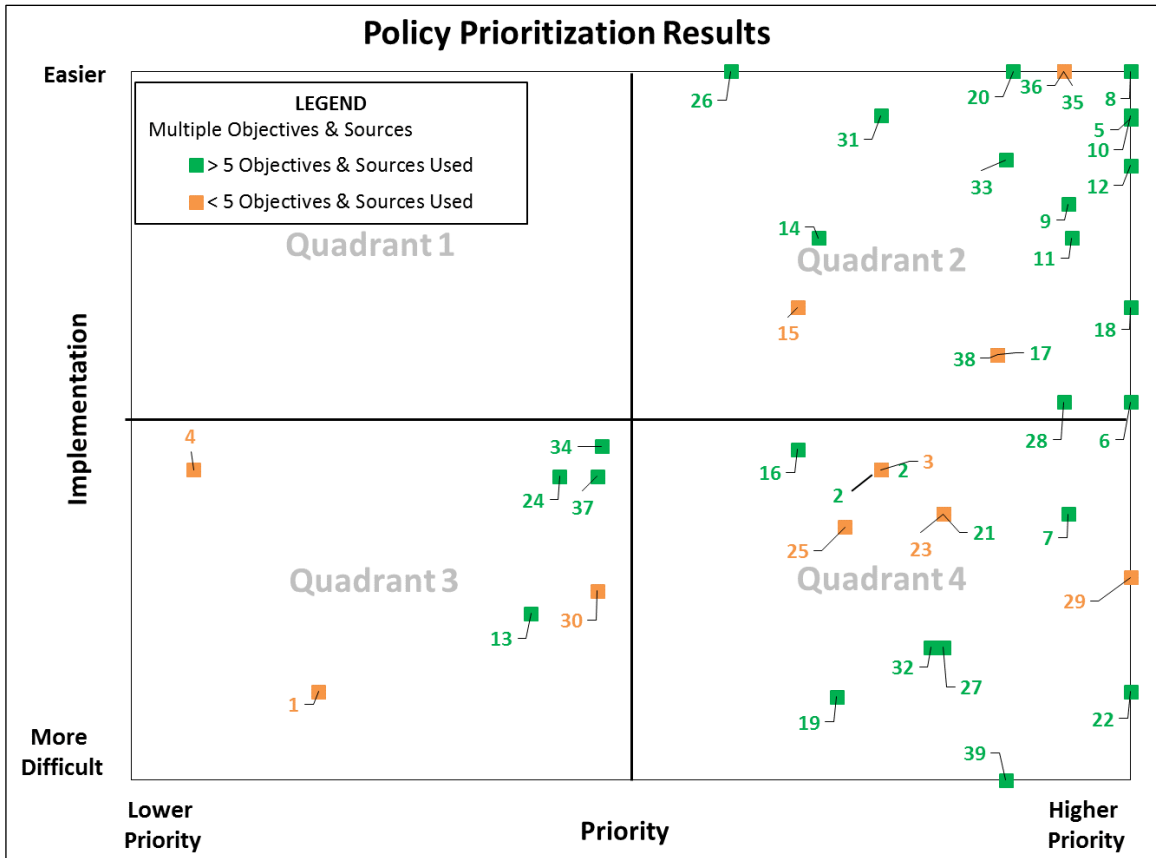

Figure 9.22 Policy & Program Classification Results

Figure 9.22 presents the number of policies and programs in each quadrant and illustrates that the majority are deemed higher priorities. Figure 9.22 also characterizes policies that meet multiple sources or objectives, which are indicated by a green square. The aim is to focus on policies and programs in quadrant 2 first as "quick wins." No policies or programs were identified to be in quadrant 1. Policies and programs in quadrant 3 are the lowest priority and more difficult to implement and as such would be revisited last.

9.7.5 Prioritization of Policies and Programs

The consolidated list of 39 prioritized policies and programs developed as part of the Plan are presented in this section. Prioritized policies are those that are considered higher priority, easier to implement, were recommended by multiple sources, and could have the greatest impact in achieving One Water LA Objectives and supporting the Sustainable City pLAN Goals. Table 9.8 summarizes the policy number and policy or program concept language. A detailed table that includes policy and program considerations describing suggested actions and implementation strategies for each policy is included in Appendix D of this Summary Report. The appendix table also identifies recommended lead and support agencies, policy idea sources and the number of One Water LA objectives each policy meets.

Table 9.8 Summary of Prioritized Policies and Programs Summary Report One Water LA 2040 Plan	
No.	Policy Language
Quadrant 1: Lower Priority, Easier to Implement	
n/a	No policies listed in Quadrant 1
Quadrant 2: Higher Priority, Easier to Implement	
8	Maximize use of City owned property for stormwater capture retrofits.
10	Maximize water supply opportunities in water quality compliance and improvement projects and programs.
18	Streamline the process and coordinate the timing of approvals for builders implementing LID and Green Building requirements.
11	Create a city-wide database to identify collaborative opportunities for water-related multi-benefit projects.
20	Create a vehicle for continued department and regional agency collaboration beyond One Water LA 2040 Plan Development.
33	Require Green Street implementation to use sustainable elements and native or climate-appropriate flora compatible with local biomes.
17	Create a process to expedite approval of public projects that help meet the Sustainable City pLAN, Watershed Management Programs, and One Water LA's objectives.
38	Develop guidelines for Onsite Treatment Facilities (OSTFs) that protect public health and outline wastewater and recycled water systems' operation.
14	Update the Street Tree Selection Guide to better address climate change and water concerns.
15	Identify a sufficient water supply for establishing and maintaining green infrastructure.
5	Develop robust stormwater pollution source control education measures that increase awareness and public participation.
12	Maximize opportunities to incorporate integrated water management strategies, including green infrastructure, into on-going and emerging opportunities.
6	Simplify the process and remove barriers to installing parkway swales and other distributed green infrastructure BMPs in the public right-of-way.
9	Develop templates for standardized maintenance agreements and provide training to ensure maintenance of collaborative stormwater projects in the City.
35	Expand education and engagement programs on potable reuse.
36	Expand "how to" training and education programs to increase understanding of green infrastructure systems, increase implementation participation, and improve performance.
28	Create a program to facilitate partnerships between City departments, regional agencies, and Non-Profit Organizations for water-related projects and programs.
31	Expand partnerships between the City and academia to advance water-related research and innovation.
26	Develop property owner recognition programs to promote and acknowledge stormwater capture retrofits and other sustainable practices.

Table 9.8 Summary of Prioritized Policies and Programs	
Summary Report	
One Water LA 2040 Plan	
No.	Policy Language
Quadrant 3: Lower Priority, More Difficult to Implement	
34	Explore the feasibility of requiring the Sustainable Infrastructure Certification program Envision for large projects and create a program for staff certification.
30	Explore the potential for establishing an Enhanced Infrastructure Financing District or other appropriate funding mechanism to fund capital projects and sustainable operations and maintenance.
24	Create a "Percent for Green" fund that supports constructing Green Street facilities and dedicate a minimum percent for green infrastructure.
13	Investigate the development of a stormwater capture retrofit ordinance that would require installing stormwater capture projects in homes upon resale.
1	Update efficiency requirements in City's retrofit on resale program.
4	Develop best method to encourage drainage water from swimming pools to be discharged into the sewer system rather than a street or storm drain.
37	Develop BMP training and certification programs for construction industry and landscape professionals.
Quadrant 4: Higher Priority, More Difficult to Implement	
29	Develop tools and best methods to facilitate agency cost-sharing for multi-benefit projects and programs.
39	Develop a fee structure and payment guidelines for on-site treatment systems that reflect collection and treatment system impacts and costs.
21	Develop a protocol for when and how private property owners will maintain the City's right-of-way stormwater improvements.
32	Integrate climate adaptation, mitigation, and resilience principles into the planning, design, construction, and operations of water-related projects.
19	Identify the process or entity that will coordinate and manage all street and alley improvement efforts in the City.
16	Create a vehicle that allows for shared operation and maintenance duties between multiple public agencies or public/private entities for stormwater BMPs.
22	Evaluate and implement the most effective methods to incentivize stormwater capture retrofits.
7	Simplify the process and remove barriers to installing distributed green infrastructure BMPs on private properties in the City.
23	Develop incentive programs to encourage reducing paved areas and increasing permeable pavements.
27	Create a program to evaluate and facilitate public-private partnerships for water projects.
2	Research best method and establish tracking system for graywater installations throughout the city. Consider potential impacts of graywater systems on water supply needs.
3	Develop graywater user education information and signage for areas irrigated with graywater.
25	Evaluate the feasibility of a program that allows properties to generate Stormwater Retention Credits (SRCs) for voluntary implementation of green infrastructure that reduces stormwater runoff.

9.7.6 Policies Presented to the Water Cabinet

Another step completed by the One Water LA Team, Executive Management from LASAN, LADWP, and the Mayor's Office was to present and identify policies requiring the greatest level of City Department and Regional Agency collaboration to Mayor Garcetti's Water Cabinet. The Water Cabinet includes representatives from the Mayor's office, the Chief Sustainability Officer, senior managers from LADWP, Bureau of Sanitation, Department of Recreation and Parks, and a representative from the City's Proposition O Citizens Oversight Advisory Committee. The Water Cabinet was formed in 2014 to promote development of future projects and policies to achieve increased water sustainability.

The One Water team presented the top 10 list of policy ideas that focused on integration to the Water Cabinet to help advance the associated policies and programs. The Water Cabinet prioritized the following top 3 policy ideas for further development and advancement with the associated City departments:

- Policy #12 – Maximize opportunities to incorporate integrated water management strategies, including green infrastructure, into on-going and emerging opportunities
- Policy #11 – Create a city-wide database to identify collaborative opportunities for water-related multi-benefit projects
- Policy #8 – Maximize use of city owned property for stormwater capture retrofits

9.7.7 Future Policy and Program Considerations

All 39 prioritized policies and programs are intended to remove barriers and increase efficiency. However, continued collaboration with numerous City departments, regional agencies, stakeholders, and elected officials within the City is needed to further refine the policies and conduct thorough feasibility assessments. Implementing the majority of recommended policies and programs will result in cost impacts including rebates, progress monitoring, and administrative support. Future studies on these costs and the anticipated benefits will need to be conducted to help prioritize the policy ideas with the greatest benefits. Due to current lack of available cost information, the Plan does not include any cost estimates related to implementing policies and programs. Recognizing that policies and programs are a key component to a One Water approach, it is recommended that the City conduct a feasibility analysis for the policies and programs. The phasing of policies and programs will take place once this feasibility analysis has been completed.

As the City makes progress addressing the prioritized policies and programs described in this Chapter, there will be a more thorough examination of the policy and program considerations, and a clearer implementation strategy will emerge. Below are some of the relevant issues that City leaders should consider as progress is made. The fundamental benefits of investment in stormwater programs, the consequences of potential non-compliance, and the balancing of these considerations relative to other City priorities will be an ongoing consideration. It is recommended that the City further evaluate the Plan's prioritized policy list, which is described in detail in TM 13.1 (see Volume 7).

9.8 PROJECT TIMELINES SUMMARY

This section presents a summary of the timelines for the current integration opportunities; future integration opportunities and strategies; wastewater projects; and stormwater projects presented earlier in this section.

A summary of capital costs phasing by project category is provided in Table 9.9, and are also graphically depicted on Figure 9.23. As shown, the estimate combined capital cost of all projects presented in this timeline is \$13.4 billion. This includes \$3.9 billion in costs for the near-term phase, \$3.3 billion for the mid-term phase, and \$6.2 billion for the long-term phase. A more detailed capital cost summary by project type and category is provided in Table 9.10.

Project Category	Project Phase			
	Near-Term (2018-2020) (\$M)	Mid-Term (2021-2030) (\$M)	Long-Term (2031-2040) (\$M)	Total (2018-2040) (\$M)
Current Integration Opportunities	\$297	\$1,000	\$500	\$1,797
Future Integration Opportunities	\$85	\$1,090	\$1,350	\$2,525
Wastewater Projects	\$1,030	\$423	\$1,937	\$3,390
Stormwater Projects and Programs	\$2,538	\$761	\$2,292	\$5,591
Total	\$3,950	\$3,274	\$6,079	\$13,303

Note:
(1) All costs are rounded to the nearest \$1 million.

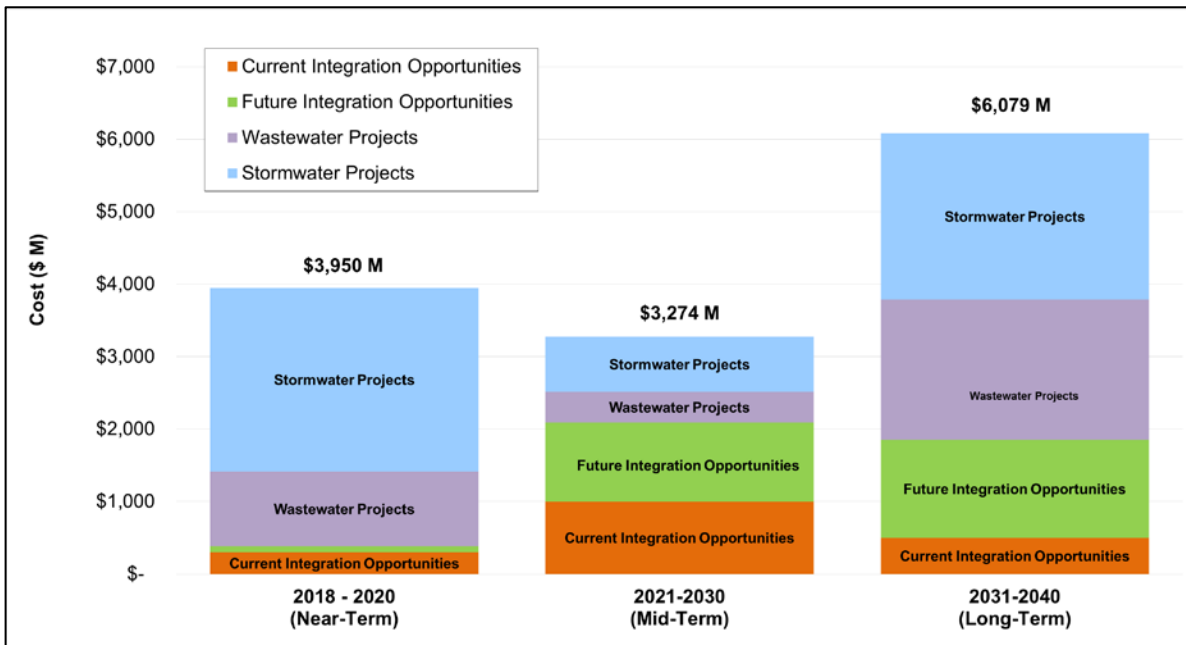

Figure 9.23 Summary of Capital Cost Phasing by Project Category

Project Category	Project and Subcategory Descriptions	2018 - 2020 (Near-Term)	2021-2030 (Mid-Term)	2031-2040 (Long-Term)	Total (\$M)	Total (%)
Current Integration Opportunities	Rancho Park Water Reclamation Facility	\$58	\$0	\$0	\$58	0.4%
	Advanced Treated Recycled Water Delivery to LAX and Scattergood Generating Station	\$51	\$0	\$0	\$51	0.4%
	Off-Site Stormwater Capture at LAUSD Schools	\$17	\$0	\$0	\$17	0.1%
	Restoration of G2 Parcel at Taylor Yard	\$76	\$0	\$0	\$76	0.6%
	Water Management Strategies for the LA Zoo's Master Plan	\$95	\$0	\$0	\$95	0.7%
	Rory M. Shaw Wetlands Park	\$0	\$50	\$0	\$50	0.4%
	MacArthur Park	\$0	\$50	\$0	\$50	0.4%
	Caballero Creek Park	\$0	\$50	\$0	\$50	0.4%
	Wilmington Waterfront Development	\$0	\$50	\$0	\$50	0.4%
	LA River Bike Path	\$0	\$50	\$0	\$50	0.4%
	Other Integration Opportunities (15)	\$0	\$750	\$0	\$750	5.6%
	Other Integration Opportunities (10)	\$0	\$0	\$500	\$500	3.8%
	Subtotal	\$297	\$1,000	\$500	\$1,797	13.5%
Future Integration Opportunities	5 Dry Weather Low Flow Diversions	\$0	\$110	\$0	\$110	0.8%
	8A LA River Recharge into LA Forebay	\$0	\$980	\$0	\$980	7.4%
	13 MBR at Hyperion WRP to Regional System	\$0	\$0	\$900	\$900	6.8%
	15 Tillman WRP to LAAFP	\$0	\$0	\$310	\$310	2.3%
	17 LA-Glendale WRP to Headworks Reservoir	\$0	\$0	\$140	\$140	1.1%
	22 East-West Valley Interceptor Sewer	\$85	\$0	\$0	\$85	0.6%
	Subtotal	\$85	\$1,090	\$1,350	\$2,525	19.0%
Wastewater Projects	Collections System	\$641	\$78	\$22	\$741	5.6%
	Tillman WRP	\$146	\$121	\$350	\$618	4.6%
	LA-Glendale WRP	\$72	\$75	\$80	\$227	1.7%
	Hyperion WRP	\$106	\$116	\$1,280	\$1,501	11.3%
	Terminal Island WRP	\$65	\$33	\$204	\$303	2.3%
	Subtotal	\$1,030	\$423	\$1,937	\$3,390	25.5%
Stormwater Project	Regional Grey	\$106	\$0	\$476	\$582	4.4%
	Regional Green	\$739	\$383	\$1,329	\$2,451	18.4%
	Distributed Green	\$1,693	\$378	\$487	\$2,558	19.2%
	Subtotal	\$2,538	\$761	\$2,292	\$5,591	42.0%
Grand Total (\$M)		\$3,950	\$3,274	\$6,079	\$13,303	100.0%
Grand Total (%)		29%	25%	46%	100%	n/a

The cost distribution of all project categories is illustrated on the pie chart shown on Figure 9.24. As shown, stormwater projects and programs contribute to the largest portion of the total cost (\$5.6 billion or 42 percent), followed by wastewater projects (\$3.4 billion or 25 percent) and future integration opportunities and strategies (\$2.6 billion or 20 percent). The smallest cost category is the current integration opportunities (\$1.8 billion or 13 percent). It should be noted that a large portion of the future integration opportunities consists of major water recycling projects, which also include advanced treatment facilities which would need to be constructed at the City's WRPs. To avoid double counting, these future concepts are maintained as a separate category.

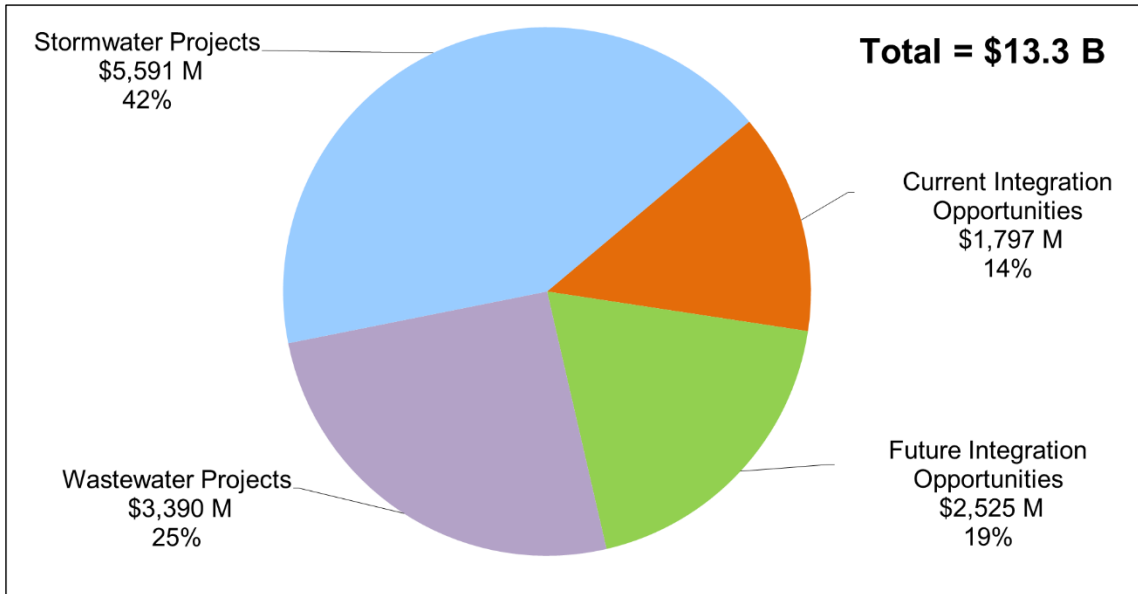

Figure 9.24 Cost Distribution Summary by Project Category

It should be noted that the total potential fiscal impact of \$13.3 billion is based on the assumption that all plan recommendations would be implemented. The recommended timeline for implementation of all project categories presented in this chapter is summarized on Figure 9.25. However, some recommendations may not move forward due to unforeseen circumstances, regulatory constraints, and/or funding limitations. In addition, many projects require certain triggers to occur before a project or program can be implemented. The following section describes a variety of project triggers that could impact the implementation of Plan recommendations.

PROJECT CATEGORIES	NEAR-TERM			MID - TERM										LONG-TERM												
	2018	2019	2020	2021	2022	2023	2024	2025	2026	2027	2028	2029	2030	2031	2032	2033	2034	2035	2036	2037	2038	2039	2040			
Current Integration Opportunities																										
• Top 5 Case Studies (5)	\$297 M																									
• Other Top 10 Case Studies (5)				\$250 M																						
• Other Integration Opportunities (15)				\$750 M																						
• Other Integration Opportunities (10)														\$500 M												
Wastewater Projects (see Wastewater Facilities Plan)																										
• Donald C. Tillman WRP	\$146 M			\$121 M										\$350 M												
• LA-Glendale WRP	\$72 M			\$75 M										\$80 M												
• Hyperion WRP	\$106 M			\$116 M										\$1,280 M												
• Terminal Island WRP	\$65 M			\$33 M										\$205 M												
• Conveyance Projects	\$642 M			\$78 M										\$22 M												
Stormwater Projects (see Stormwater & Urban Runoff Facilities Plan)																										
• Ballona Creek Watershed	\$1,343 M																						\$27 M			
• Dominguez Channel Watershed	\$163 M			\$22 M										\$114 M												
• Santa Monica Bay & Marina Del Ray Watershed	\$518 M													\$13 M												
• Upper LA River Watershed	\$513 M			\$739 M										\$2,138 M												
Trigger-based Future Integration Opportunities																										
• LA River to LA Forebay				Concept Option #8A = \$980 M																						
• Low Flow Diversions				Concept Option #5 = \$110 M																						
• Donald C. Tillman WRP														Concept Option #15 = \$310 M (or #9, 16)												
• LA-Glendale WRP														Concept Option #17 = \$140 M												
• Hyperion WRP														Concept Option #13 = \$900 M (or #10, 11, 18)												
• East West Valley Interceptor Sewer	Concept Option #22 = \$85 M																									
Total by Phase	\$3,950 M			\$3,274 M										\$6,079 M												

to 2040
and beyond
→

Figure 9.25
Summary of Recommended
Timelines by Project Category
 One Water LA 2040 Plan
 Summary Report

9.9 ADAPTIVE IMPLEMENTATION STRATEGY

This section starts with a description of the key project triggers that could impact the timing and feasibility project implementation. Subsequently, the trigger-based implementation strategy is described and illustrated with trigger charts for each of the City's four WRPs and the LA River. This trigger-based implementation process allows adaptive decision-making as system conditions and needs evolve over time.

9.9.1 Project Triggers

When reviewing the phasing of projects, programs, and concept options, there are a number of events and conditions that can have an impact on the timing of the baseline CIP. These events and conditions as also referred to as "triggers."

Due to the complexity and magnitude of the One Water program, there are a large number of potential unforeseen conditions and trigger events. This means the planned phasing should be taken as preliminary and is likely to change.

In the planning process there may be a number of projects that are either not feasible or not required under future circumstances. By identifying the primary trigger events for the major recommended projects, programs, and concept options, it is possible to create a trigger-based implementation strategy.

The triggers that could impact the phasing of projects recommendations identified in this Plan can be divided into five primary categories:

1. Asset Condition
2. Climate Risk and Resilience
3. Demands and Flows
4. Institutional Agreements
5. Regulatory

The definitions and potential outcomes of triggers that fall under each of these five categories are described in the following subsection. Some triggers are also illustrated with one or more practical examples to clarify the implications of each trigger.

It should be noted that funding is not included as a trigger because sufficient funding is a common requirement for all projects. Although insufficient funding can certainly postpone, downsize, or eliminate a project, it was decided that funding should be considered as an implementation challenge rather than a trigger.

9.9.1.1 Asset Condition Triggers

The condition of water or wastewater infrastructure assets can become a trigger to rehabilitate or replace a component or entire facility. As this Plan only includes detailed CIPs for wastewater and

stormwater infrastructure, this Plan does not include asset condition triggers for rehabilitation and replacement (R&R) of potable or recycled water infrastructure elements. However, similar triggers also apply to (recycled) water system infrastructure R&R projects, which are part of Los Angeles Department of Water and Power's (LADWP) asset replacement program (not included in this Plan). However, impacts to all relevant CIPs should be considered in assessing feasibility of these projects prior to implementation.

Trigger: Wastewater system asset condition assessment results identify deterioration below a predefined level of service

Potential Outcome: Creates the need for the wastewater asset (e.g., conveyance system, water reclamation plant components, and outfalls) to be replaced or rehabilitated within a prescribed timeframe to prevent issues with performance reliability.

Example 1: The condition of a sewer trunk main warrants the need for immediate or near-term repair or replacement to avoid risk of failure, such as a trunk main collapse that could create sewer system overflows, sinkholes, and/or other types of damage.

Example 2: The condition of the water reclamation plant's primary treatment system warrants the need for immediate or near-term repair or replacement to avoid risk of treatment disruptions, which would result in effluent discharges that exceed the permit requirements. This could result interruptions of recycled water supplies and fines.

Trigger: Stormwater system asset condition assessment results identify deterioration below a predefined level of service

Potential Outcome: Creates the need for the stormwater asset (e.g., pumping plants, low flow diversions, or BMPs) to be replaced or rehabilitated within a prescribed timeframe to prevent issues with performance reliability.

Example: The condition of a BMP is determined to be such that eminent failure is near or excessive sediment buildup warrants the need for immediate or near-term repair or replacement. The purpose is so that the BMP continues to capture SW for reuse, infiltration and treatment.

9.9.1.2 Climate Risk and Resilience Triggers.

There are multiple types of risks associated with climate change that can impact the need for and sizing of stormwater and wastewater facilities to mitigate these risks. The primary risks identified that pertain to projects identified in this Plan are related to future prolonged droughts, increased number of hot days, changes in the size and frequency of peak storm events, and sea level rise.

Trigger: Future prolonged and more frequent droughts

Potential Outcome: Creates the need to develop new local water supplies and/or water supply portfolio diversification, as well as, climate resilient infrastructure.

Example 1: Prolonged reduction in precipitation results in declining groundwater levels of potable water aquifers, limiting the amount of groundwater pumping capacity and operating safe yield of groundwater basins, and highly concentrated pollutant loads affecting stormwater

and urban runoff water quality. These effects can be mitigated with either stormwater capture methods and/or groundwater augmentation with recycled water.

Example 2: Prolonged drought impacts can result in failure of stormwater pump stations. When pumps are not operated for long periods of time, it increases the likelihood of pumps not working when needed. New O&M protocols are required to exercise all pumps on a regular basis.

Example 3: Risk of (wild) fires increases with prolonged drought. The City's water, wastewater, and stormwater facilities need to be protected in fire prone areas to increase the likelihood of continued system operations during fires.

Example 4: The vegetation selected for bioswales and other stormwater BMPs needs to be completely drought resistant. However, additional water may be required during droughts to maintain proper treatment function.

Trigger: Changes in size of peak storm events

Potential Outcome: Creates the need for adjustment of flood zone mapping, flood risk mitigation projects, sizing of stormwater facilities, and/or construction of stormwater detention/retention/recharge facilities to respond to peak storm events such as atmospheric rivers and storm super cells.

Example 1: More extreme precipitation events can increase the likelihood and extent of flooding in certain areas in the city. This may require upsizing of or adding additional stormwater management infrastructure.

Example 2: An increase in the size of storm events can create flooding risks in new areas that historically have not been impacted by flood events. This may require new stormwater management solutions in certain parts of the city.

Trigger: Changes in frequency of peak storm events

Potential Outcome: Creates the need to change design criteria and mitigation measures, and sizing of stormwater facilities to respond to peak storm events such as atmospheric rivers and storm super cells.

Example 1: An existing storm drain that was sized to handle a 50-year flood event, may reach or exceed full capacity more often than expected. The likelihood of flooding in the upstream watershed will increase beyond the original design criteria. Changes in peak storm frequency may require new design criteria and changes in stormwater infrastructure O&M.

Example 2: Re-evaluation of peak storm frequency may result in new design criteria that would require larger capacity infrastructure, including upsizing of existing storm drains and facilities, as well as construction of new stormwater infrastructure in areas that are currently managed with surface sheet flow.

Trigger: Sea level rise

Potential Outcome: Creates the need for protective shoring and other waterproofing solutions for critical facilities.

Example 1: Water reclamation plants (WRPs) located near the ocean could be damaged due to a combination of sea level rise and storm surges or a tsunami. Protective shoring would prevent

seawater from entering a WRP and inundation of facilities that could disrupt operations. This includes constructing water-proof walls and enclosures, as well as raising electrical equipment on the ground to above the expected water level.

Example 2: Some of the below-surface wastewater and stormwater lift stations that are located in close proximity to the coast could be inundated due to sea level rise, which would result in sewer or stormwater overflows. Waterproofing the below grade facility, utilization of submersible pumps, modifying backup power, changing pump type, and/or evaluating electrical systems could be required.

9.9.1.3 **Demands and Flows Triggers**

The sizing and timing of many water-related projects are based on the estimated demands and flows. It is, therefore, critical to monitor changes to the projected water demands, recycled water demands, wastewater flows, and stormwater flows that were utilized to size the recommended projects. As demonstrated in the past, these changes can involve both increases and decreases in anticipated demands and flows.

***Trigger:* Increase in recycled water demands**

Potential Outcome: Creates the opportunity for a project to recycle tertiary or advanced treated wastewater flows to offset potable water demands for non-potable uses or augment groundwater aquifers.

Example 1: A new commercial or industrial customer that can utilize recycled water for its end use or production process could provide an opportunity to expand the City's existing purple pipe network and increase the City's non-potable water reuse demand. It must be noted that the actual implementation of any further non-potable system expansions strongly depend on the customer's water demand, water quality needs, and location in relation to existing facilities and recycled water supply availability.

Example 2: New groundwater replenishment projects in the San Fernando, Central, or West Coast Basins could increase the demand for recycled water from one or more of the City's WRPs.

***Trigger:* Increased conservation**

Potential Outcome: Reduces the need for potable water supplies to meet the overall city demand. However, a secondary outcome is a reduction in wastewater flows and, therefore, less recycled water availability, especially if water conservation is achieved with indoor measures.

Example 1: If customers reduce per capita demand beyond the currently projected water conservation targets, then the City will not rely as heavily on imported water. This will result in increased supply resiliency and reduced financial impacts from imported water rate increases.

Example 2: If customers in the northwestern part of the San Fernando Valley reduce the per-capita demand beyond the currently projected water conservation targets, flows to the Donald C. Tillman Water Reclamation Plant (DCTWRP) will decline further. This could then trigger a delay or size reduction of any of the proposed recycled water projects that would be supplied from this facility.

Trigger: Decreased conservation

Potential Outcome: Increases the need for potable water supplies to meet the overall city demand. Additionally, a secondary outcome is an increase in wastewater flows and, therefore, more recycled water availability, especially if less water conservation is achieved with indoor measures.

Example: If customers in the northwestern part of the San Fernando Valley do not reduce the per-capita indoor demand per currently projected water conservation targets, flows to the DCTWRP will be greater than the current estimates. This could then trigger the ability to recharge more recycled water in the San Fernando Basin through the GWR Project and/or reduce the need for any of the proposed flow management options intended to increase wastewater flows to this facility.

9.9.1.4 Institutional Agreement Triggers

One of the key Guiding Principles of One Water LA is to promote and streamline collaboration between City departments and other regional agencies, and nearly all recommended projects will require some type(s) of institutional agreement(s).

Some of the identified future concept options will require new institutional agreements with regional agencies and/or between City departments or bureaus. As these agreements are likely to be complex to develop and negotiate, institutional agreements are considered triggers. Based on the proposed future concept options, there are multiple examples of major institutional agreement types that can be distinguished as triggers.

Trigger: A water exchange agreement between the City and a regional water agency where the City would deliver water from one of its WRPs to another agency for the purpose of a potable reuse project.

Potential Outcome: Creates the need to improve the quality of WRP effluent requiring various treatment plant upgrades that could range from membrane bioreactors (MBRs) to advanced treatment with reverse osmosis or other technology. At a minimum, the water exchange agreement would define flow rates, water quality parameters, operational conditions, and a pricing structure. The water agency would utilize the purchased water for a potable reuse project with raw water, treated water, or groundwater augmentation.

Example 1: The City would reach a water exchange agreement with Metropolitan Water District of Southern California (MWDSC), who would utilize the purchased water from Hyperion Water Reclamation Plant (HWRP) to augment supplies for its regional recycled water program currently in development with the Los Angeles County Sanitation Districts.

Example 2: The City would reach a water exchange agreement with the Water Replenishment District (WRD) to deliver MBR or advanced treated recycled water from the HWRP for a potable reuse project with groundwater augmentation in the West Coast Basin and/or Central Basin.

Example 3: The City would reach another water exchange agreement with West Basin Municipal Water District to deliver more flows from the HWRP to West Basin's system for non-potable reuse, seawater barrier injection, water transfer to the Terminal Island Water Reclamation Plant

(TIWRP), or a future potable reuse project in the West Coast Basin or Central Basin in collaboration with WRD.

Example 4: The City would reach a water exchange agreement with LA County Sanitation Districts (LACSD), Long Beach Water Department, or any other agency to deliver recycled water from any of the City's WRPs for non-potable or potable reuse purposes.

***Trigger:* Cost-sharing agreement between City departments, regional water agencies, and/or other local entities**

Potential Outcome: Creates the opportunity to move forward on feasibility analysis, preliminary design, final design, construction, and/or operation of integrated projects that involve multiple project partners.

Example 1: The City would establish a benefit-based cost-sharing agreement between Los Angeles Sanitation (LASAN), LADWP, and the LA Zoo to fund and implement stormwater capture facilities that have a water supply, water quality, and/or flood risk mitigation benefits.

Example 2: The City would establish a cost-sharing agreement with a regional agency to construct advanced treatment facilities at the HWRP and deliver purified water for a regional potable reuse project.

***Trigger:* Operations and maintenance agreement between City departments, regional water agencies, and/or other local entities**

Potential Outcome: An agreement between two or more entities that specifies the roles and responsibilities of each City department and/or agency to operate and maintain treatment and/or conveyance facilities of integrated projects that involve multiple project partners.

Example 1: The City would establish a (standardized) inter-departmental O&M agreement between LASAN and the Department of Recreation and Parks (RAP) to operate and maintain stormwater capture and treatment facilities located at City-owned parks and other recreational spaces. By standardizing such an agreement, the implementation of many proposed stormwater projects could potentially be accelerated.

Example 2: The City would establish an O&M agreement between LASAN and the High-Speed Rail (HSR) Authority to operate and maintain stormwater capture and treatment facilities along portions of the future HSR alignment.

9.9.1.5 **Regulatory and Legislative Triggers**

When preparing a plan with a 25-year planning horizon, it is important to consider potential changes in regulations that pertain to water quality, public health, discharge requirements, and, most certainly, potable reuse. New legislation can become drivers for certain projects and should be monitored. Based on the future concept options described in Chapter 6, five major regulatory triggers were identified as described below.

***Trigger:* Compliance deadlines of existing TMDL limits for watersheds overlying the City**

Potential Outcome: This existing trigger has already created the need for stormwater management projects to be in place within a prescribed timeline to meet total maximum daily

load (TMDL) targets within each of the five watersheds overlying the City. These include the Ballona Creek watershed, Upper LA River watershed, Dominguez Channel watershed, Santa Monica Bay watershed, and the Marina Del Rey watershed.

Example: The Metals and Bacteria TMDL for the Ballona Creek Watershed goes into effect in 2021. The City needs to have the necessary stormwater quality improvement projects (both regional and distributed) constructed and operational by this deadline to avoid fines. This also includes the necessary stormwater quality monitoring programs and reporting mechanism.

***Trigger:* Approval of a wastewater change petition (Water Code Section 12111) by the Division of Water Rights**

Potential Outcome: Creates the opportunity to make a change in the point of discharge, place of use, or purpose of use of treated wastewater that results in decreasing the flow in any portion of a watercourse. Instead of discharging wastewater effluent to the Los Angeles River and ocean, wastewater effluent could be utilized for non-potable reuse and potable reuse projects to reduce imported water supply needs.

Example: If the Division of Water Rights would approve a reduction in minimum wastewater effluent discharges from the DCTWRP into the LA River, there would be more recycled water flow availability for groundwater recharge in the San Fernando Basin.

***Trigger:* Approval of potable reuse with raw water augmentation regulations**

Potential Outcome: Creates the opportunity for potable reuse with raw water augmentation by allowing delivery of advanced treated recycled water to the intake of a conventional water treatment plant for additional treatment prior to distribution.

Example: Approval of potable reuse with raw water augmentation would allow the City to pump advanced treated recycled water from any of the City's four WRPs to the inlet of the LA Aqueduct Filtration Plant (owned by LADWP) or any other water treatment plants in the Los Angeles area.

***Trigger:* Approval of potable reuse with treated water augmentation regulations**

Potential Outcome: Creates the opportunity for potable reuse with treated water augmentation by allowing delivery of advanced treated water directly into the distribution system, most likely after some type of engineered storage buffer to provide sufficient safety response time in case of a treatment plant upset or other unforeseen condition.

Example: Approval of potable reuse with treated water augmentation would allow the City to pump advanced treated recycled water from the Los Angeles-Glendale Water Reclamation Plant (LAGWRP) into the Headworks Reservoir prior to distribution, assuming the Headworks Reservoir would be converted and properly equipped with the necessary telemetry and water-quality sampling stations.

***Trigger:* Toxicity limit in a receiving water body is reached**

Potential Outcome: Creates the need for stormwater treatment or additional wastewater treatment to be implemented to improve the water quality and/or to decrease release of untreated water to downstream water bodies, such as rivers, creeks, lakes, harbors, and ocean.

Example: Advanced treated recycled water from the TIWRP is utilized for a variety of purposes, including augmentation of Machado Lake for evaporation loss. However, Machado Lake is primarily supplied by stormwater and urban runoff from a heavily industrial watershed, comprising the water quality of Machado Lake close to allowable toxicity limits. If these limits are reached, the ability to augment this lake from the TIWRP is no longer feasible and would need to be interrupted.

***Trigger:* Future TMDL limits of new pollutants for watersheds overlying the City are promulgated**

Potential Outcome: Creates the need for potential additional stormwater management projects to be in place within a prescribed timeline to meet future TMDL targets within each of the five watersheds overlying the City.

Example: There is currently no TMDL in place for toxic pollutant loads in the Ballona Creek or Upper LA River watersheds. If currently planned projects that are designed to meet the compliance needs of the existing Ballona Creek Metals and Bacteria TMDLs would not be sufficient to remove toxics to target levels, additional stormwater quality improvement measures would need to be implemented.

***Trigger:* More stringent water reclamation plant discharge requirements**

Potential Outcome: Creates the need for additional wastewater treatment processes and/or implementation of recycling projects to comply with more stringent water quality standards for wastewater effluent and/or reduction of flow volumes.

Example 1: The discharge limit of certain constituents for the WRPs discharging into the LA River would be lowered to minimize negative impact on the ecosystems developed as part of the river restoration efforts in the ARBOR reach. More stringent water quality regulations may impact hydraulic capacity of existing treatment facilities and/or trigger the need for treatment process upgrades or expansions.

Example 2: Similar to the TIWRP, the discharge from the HWRP to the ocean would be limited. Although this would likely exclude wet-weather events, such a discharge requirement would trigger the need for full-scale treatment modifications and an extensive water recycling program and facilities consisting of non-potable and/or potable reuse projects to fully utilize the dry-weather flows by a set timeframe.

***Trigger:* LID implementation and other land-use practices that reduce runoff**

Potential Outcome: Creates the opportunity to delay, downsize, and/or eliminate the implementation of stormwater management projects that are intended to meet future TMDL targets within each of the five watersheds overlying the City.

Example 1: Downsize or delay the implementation of green streets or regional stormwater projects due to large scale LID adoption by public sector landowners, such as BMPs at school sites, City parks, and other City's owned properties.

Example 2: Downsize or delay the implementation of green streets or regional stormwater projects due to large scale LID adoption by private landowners, such as on-site stormwater capture and reuse with rain barrels, rain gardens, downspout redirects, and cisterns.

9.9.2 Trigger-Based Implementation Strategy

A dynamic trigger-based implementation strategy was developed to guide the City with prioritization and the decision-making process for future implementation of the recommended projects and programs. As shown on Figure 9.24 nearly half of the total estimated cost (\$13.3 billion) is associated with stormwater projects and programs (\$5.6 billion). A large portion of the Stormwater Improvement Program (SIP) is triggered by the various existing TMDLs and, therefore, already has a specific implementation timeline as shown on Figure 9.25. The vast majority of the remaining projects, which total nearly \$6.6 billion, have much less defined timelines. Specifically, the future integration opportunities and the associated improvement projects for the City's WRPs are strongly dependent on the occurrence of a variety of project triggers described in Section 9.9.1.

The individual future integration opportunities are called "concept options." These concept options are primarily new concepts that have not been previously evaluated by the City in other planning documents. The City has not made any decision to implement any of these concept options. Through a series of workshops, stakeholder meetings, and engagement with the One Water LA team, a total of 27 new concept options were identified and developed. The purpose of these concept options is to achieve stormwater and receiving water quality objectives and increase local supply availability through collaborative projects involving multiple City departments and/or regional agencies. Based on the future integration opportunities evaluation of these 27 concept options (see Chapter 6), the most viable opportunities were selected for inclusion in the One Water Implementation Strategy.

Although some of the concept options did not score favorably due to high cost and/or limited other benefits, it should be noted that some of the concept options that are currently not included in the Implementation Strategy remain good viable alternatives. In case certain triggers do not materialize, other concept options could provide an alternative to achieve the same overall goals.

The trigger-based implementation strategy is graphically depicted on Figure 9.26, while the following subsections provide an explanation of each of the trigger-based flowcharts. As shown, the implementation strategy is organized by recycled water supply source, which includes the City's four WRPs and the LA River. For each supply source, there are multiple water reuse scenarios that are triggered by a variety of conditions. The most preferred concept option is indicated as "Priority A," while the next-best concept option is identified as "Priority B" and third best as "Priority C." It should be noted that the priorities can change in the future as the underlying conditions, assumptions, and triggers may change in the future. Hence, it is critical that the City reconsider the benefits of all concept options when deciding to move forward with the implementation of any of these concept options.

Brief descriptions and schematics of each concept option depicted on Figure 9.26 are provided in Appendix B of this Summary Report, while detailed descriptions are included in Appendix C of TM 5.2 (see Volume 5).

Hyperion Water Reclamation Plant

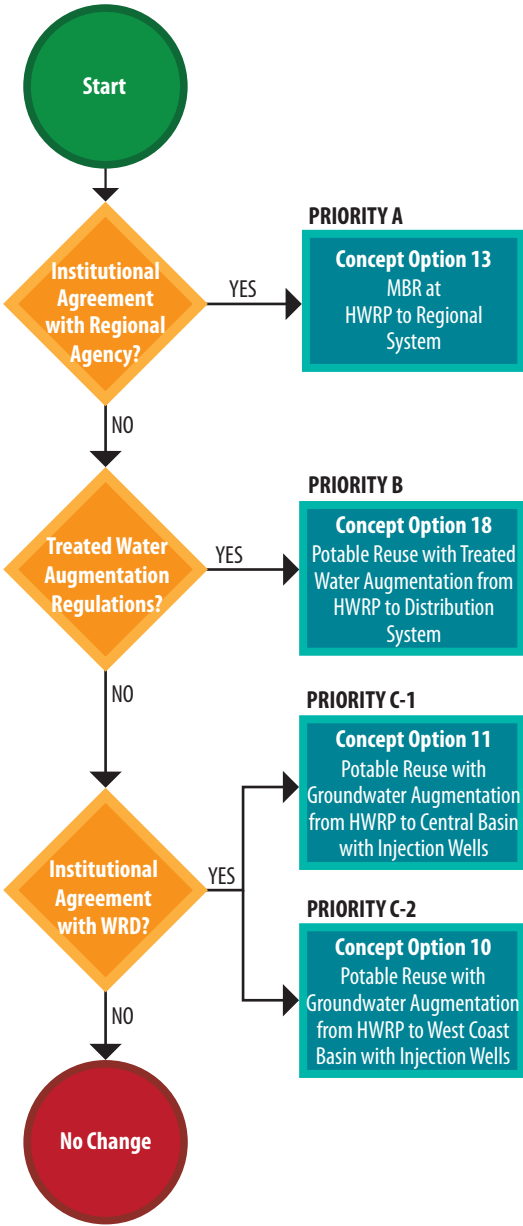

LEGEND & ACRONYMS

- ◆ Trigger
- Concept Option
- Flow Management Option

DCTWRP	Donald C. Tillman Water Reclamation Plant
GWR	Groundwater Replenishment Project
HWRP	Hyperion Water Reclamation Plant
LAGWRP	LA-Glendale Water Reclamation Plant
RWQCB	Regional Water Quality Control Board
TIWRP	Terminal Island Water Reclamation Plant
WRD	Water Replenishment District of Southern California

Disclaimer: At each trigger (decision point), evaluate all triggers and concept option priorities to consider changed circumstances in the future.

Figure 9.26
Trigger-Based Implementation Strategy for HWRP
One Water LA 2040 Plan
Summary Report

9.9.2.1 Implementation Strategy for HWRP

As shown on Figure 9.26, there are four concept options identified that involve potable reuse from the HWRP. Based on the future integration opportunities analysis involving a comprehensive list of evaluation criteria, the concept options for the HWRP were prioritized as follows:

- **Priority A: Concept Option #13** – Potable Reuse from the HWRP to the Regional System
- **Priority B: Concept Option #18** – Potable Reuse with treated water augmentation from the HWRP to the City's distribution system
- **Priority C-1: Concept Option #11** – Potable Reuse with groundwater augmentation from the HWRP to the Central Basin with injection wells
- **Priority C-2: Concept Option #10** – Potable Reuse with groundwater augmentation from the HWRP to the West Coast Basin with injection wells

It can be concluded that all concept options involve the installation of additional treatment facilities at the HWRP to deliver either MBR quality or advanced treated water for the various potable reuse project configurations. In addition, all selected concept options have the same capacity of 95,000 acre-feet per year (AFY). This capacity is based on the estimated available flow from the HWRP for future water recycling projects after consideration of existing projects, already planned projects, estimated future flow increases, and treatment losses. For Concept Options #10 and #11, the total available flow of 95,000 AFY was proportionally allocated between the Central and West Coast Basins based on the estimated storage capacity of these basins.

As shown on Figure 9.26, the most critical trigger of the highest-ranked potable reuse opportunity, Concept Option #13 (HWRP to Regional System), is the establishment of an institutional agreement with a regional project partner, such as MWDSC, LACSD, or WBMWD. In case such an agreement does not materialize, the second-highest ranked potable reuse opportunity is Concept Option #18 (Treated Water Augmentation from the HWRP to the Distribution System). The most critical trigger for this concept option is the adoption of potable reuse with treated water augmentation regulations that would allow this type of water reuse practice. In case the potable regulations are not accepted within a desired timeframe, or if the City prefers a more conventional form of water reuse, the third-best potable reuse options from the HWRP are Concept Options #10 and #11, consisting of groundwater augmentation in the West Coast and Central Basin, respectively. These two concept options will require an institutional agreement with WRD, who acts as the Watermaster of these two groundwater basins. In case such an agreement does not materialize, and potable reuse regulations are not approved, it is recommended to postpone the implementation of a large-scale potable reuse project from the HWRP, which is indicated as "No Change" on Figure 9.26.

It should be noted that there were four other concept options developed for the HWRP that were not included in the implementation strategy because the options were not considered viable at this time. The other potable reuse opportunities from the HWRP are:

- **Concept Option #14** – Potable Reuse with groundwater augmentation from the HWRP to the San Fernando Basin with injection wells
- **Concept Option #19** – Potable Reuse with treated water augmentation from the HWRP to the LADWP's distribution system via the Headworks Reservoir
- **Concept Option #20** – Potable Reuse with raw water augmentation from the HWRP to the LAAFP

However, triggers, underlying conditions, and assumptions made for the development of these concept options may change in the future. It is therefore recommended that City staff closely monitor all triggers and other circumstances that may impact the viability and prioritization of all concept options developed for the HWRP. Future changed conditions may not only change the prioritization of the concept options included as Priority A, B, and C, but also impact the viability of the other potable reuse options from the HWRP that are not included in the implementation strategy.

9.9.2.2 Implementation Strategy for DCTWRP

As shown on Figure 9.27, there are three concept options identified that involve potable reuse from the DCTWRP. Based on the future integration opportunities analysis involving a comprehensive list of evaluation criteria, the concept options for the DCTWRP were prioritized as follows:

- **Priority A: Concept Option #15** – Potable Reuse with raw water augmentation from the DCTWRP to the LAAFP
- **Priority B: Concept Option #16** – Potable Reuse with treated water augmentation from the DCTWRP to the City's distribution system
- **Priority C: Concept Option #9** – Potable Reuse with groundwater augmentation from the DCTWRP to the San Fernando Basin with injection wells

It can be concluded that all concept options involve the installation of additional treatment facilities at the DCTWRP to deliver advanced treated water for the various potable reuse project configurations. In addition, all selected concept options have the same capacity of 15,000 AFY. This capacity is based on the estimated available flow from the DCTWRP for future water recycling projects after the implementation of flow management options such as Concept Option #5 (Dry Weather Low Flow Diversions), Concept Option #22 (East West Valley Interceptor Sewer), and/or Concept Option #26 (Japanese Garden and Sepulveda Basin Lakes Recirculation).

Donald C. Tillman Water Reclamation Plant

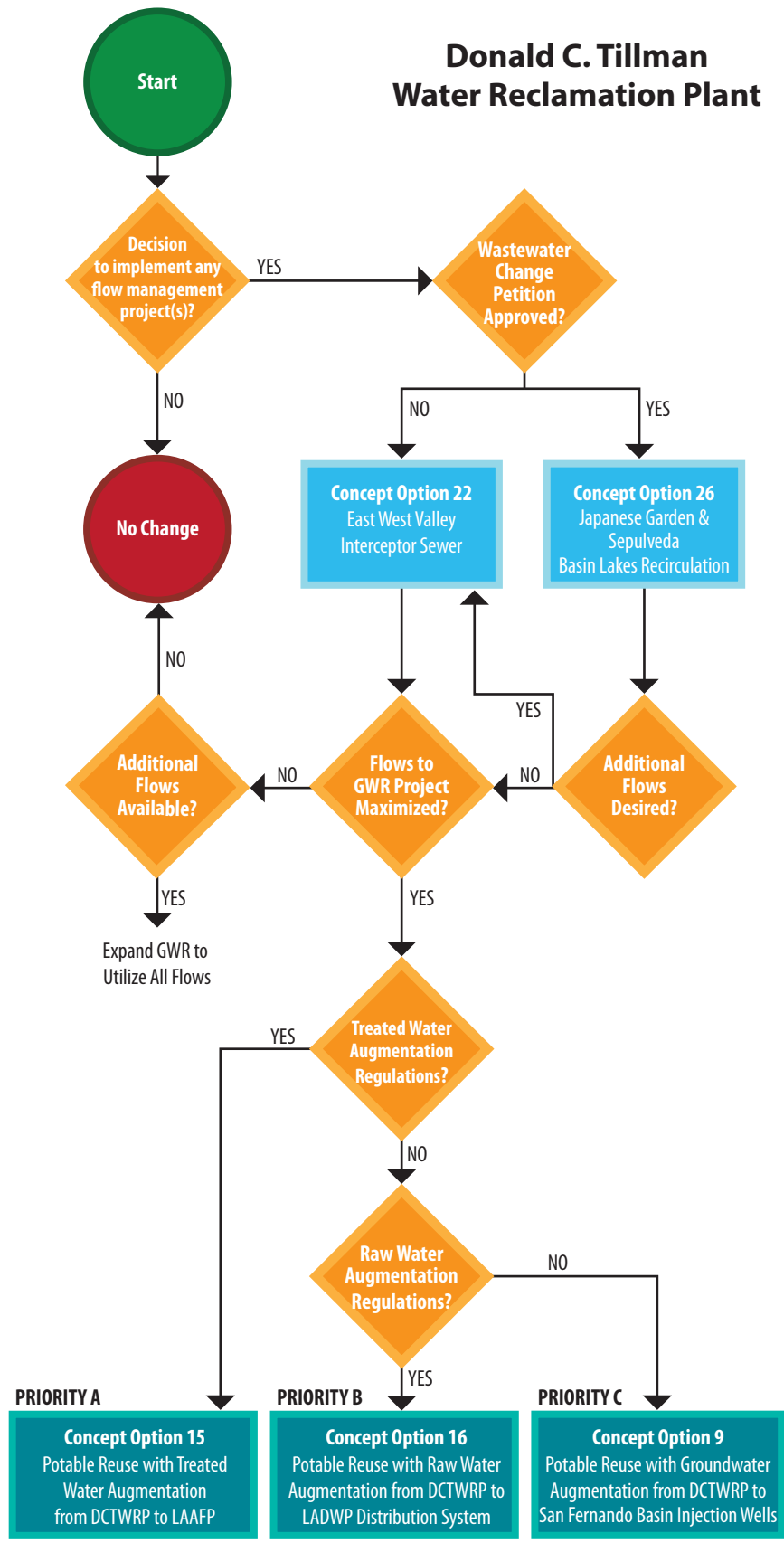

LEGEND & ACRONYMS

- ◆ Trigger
- Concept Option
- Flow Management Option

DCTWRP Donald C. Tillman Water Reclamation Plant
 GWR Groundwater Replenishment Project
 HWRP Hyperion Water Reclamation Plant
 LAGWRP LA-Glendale Water Reclamation Plant
 RWQCB Regional Water Quality Control Board
 TIWRP Terminal Island Water Reclamation Plant
 WRD Water Replenishment District of Southern California

Disclaimer: At each trigger (decision point), evaluate all triggers and concept option priorities to consider changed circumstances in the future.

Figure 9.27
Trigger-Based Implementation Strategy for DCTWRP
 One Water LA 2040 Plan
 Summary Report

As shown on Figure 9.27, the most critical trigger of any of the Priority A, B, or C options is the ability to increase wastewater flows to the DCTWRP. Due to the success of water conservation and the ongoing groundwater replenishment project, all existing flows have been accounted for. Hence, the first trigger is a decision to pursue and implement any flow management project. If and once the City makes this decision, the next trigger is the approval of a wastewater change petition from the Division of Water Rights per Water Code Section 1211 to allow a reduction in effluent discharge from the DCTWRP to the LA River.

- If this petition is approved, the City could proceed with Concept Option #26. By implementing some type of flow recirculation project for the Japanese Garden and Sepulveda Basin Lakes, a portion of the DCTWRP effluent that is currently discharged into the LA River could be repurposed for potable reuse.
- If this petition is not approved, the City would need to proceed with Concept Option #22 and increase flow availability to the DCTWRP by constructing the East-West Valley Interceptor Sewer (EWWIS) project, which consists of a 6-mile sewer force main and six lift stations to bring wastewater flows from the eastern part of the San Fernando Valley to the DCTWRP.

As shown on Figure 9.26, the next most critical triggers are related to the adoption of potable reuse regulations. The highest-ranked potable reuse opportunity (Concept Option #15 - the DCTWRP to the LAAFP) would require acceptance of potable reuse with raw water augmentation, while the second-highest concept option (Concept Option #16 - the DCTWRP to LADWP's Distribution System) would require acceptance of potable reuse with treated water augmentation. In case the potable reuse regulations are not accepted within a desired timeframe, or if the City prefers a more conventional form of water reuse, the third-best potable reuse option from the DCTWRP is Concept Option #9 (Groundwater Augmentation from the DCTWRP to the San Fernando Basin Injection Wells). In case none of the flow management strategies are feasible or the potable reuse regulations are not approved, it is recommended to postpone any new water recycling projects from the DCTWRP. This decision is indicated as "No Change" on Figure 9.27.

However, triggers, underlying conditions, and assumptions made for the development of these concept options may change in the future. It is therefore recommended that City staff closely monitor all triggers and other circumstances that may impact the viability and prioritization of all concept options developed for the DCTWRP. Future changed conditions may not only change the prioritization of the concept options included as Priority A, B, and C, but also impact the viability of the four other potable reuse options from the DCTWRP that have not yet been identified in this plan.

9.9.2.3 Implementation Strategy for LAGWRP

As shown on Figure 9.28, there are two concept options identified that involve potable and non-potable reuse from the LAGWRP. Based on the future integration opportunities analysis involving a comprehensive list of evaluation criteria, the concept options for the LAGWRP were prioritized as follows:

- **Priority A: Concept Option #17** – Potable Reuse with treated water augmentation from the LAGWRP to the City's distribution system via the Headworks Reservoir
- **Priority B: Concept Option #23** – Non-Potable Reuse expansion from the LAGWRP

Only Concept Option #17 would involve the installation of additional treatment facilities at the LAGWRP to deliver advanced treated water for potable reuse to the City's distribution system via temporary storage and monitoring in the Headworks Reservoir.

As shown on Figure 9.28, the most critical trigger of the highest-ranked potable reuse opportunity (Concept Option #17 - the LAGWRP to the Headworks Reservoir) is the adoption of potable reuse with treated water augmentation regulations that would allow this type of water reuse practice. In case the potable regulations are not accepted within a desired timeframe, or if the City prefers a more conventional form of water reuse, the second-best water recycling option from the LAGWRP is Concept Option #23, consisting of expansion of the non-potable reuse system. The most critical trigger for this concept option is new customer demand that is cost-effective to serve, considering the customer location, demand size, demand variability, and requirements. In case neither the potable reuse regulations nor any new recycled water customers that can be feasibly served materialize, it is recommended to postpone any new water recycling projects from the LAGWRP. This decision is indicated as "No Change" on Figure 9.28.

However, triggers, underlying conditions, and assumptions made for the development of these concept options may change in the future. It is therefore recommended that City staff closely monitor all triggers and other circumstances that may impact the viability and prioritization of all concept options developed for the LAGWRP. Future changed conditions may not only change the prioritization of the concept options included as Priorities A and B, but also impact the viability of the four other potable reuse options from the LAGWRP that have not yet been identified in this Plan.

LA-Glendale Water Reclamation Plant

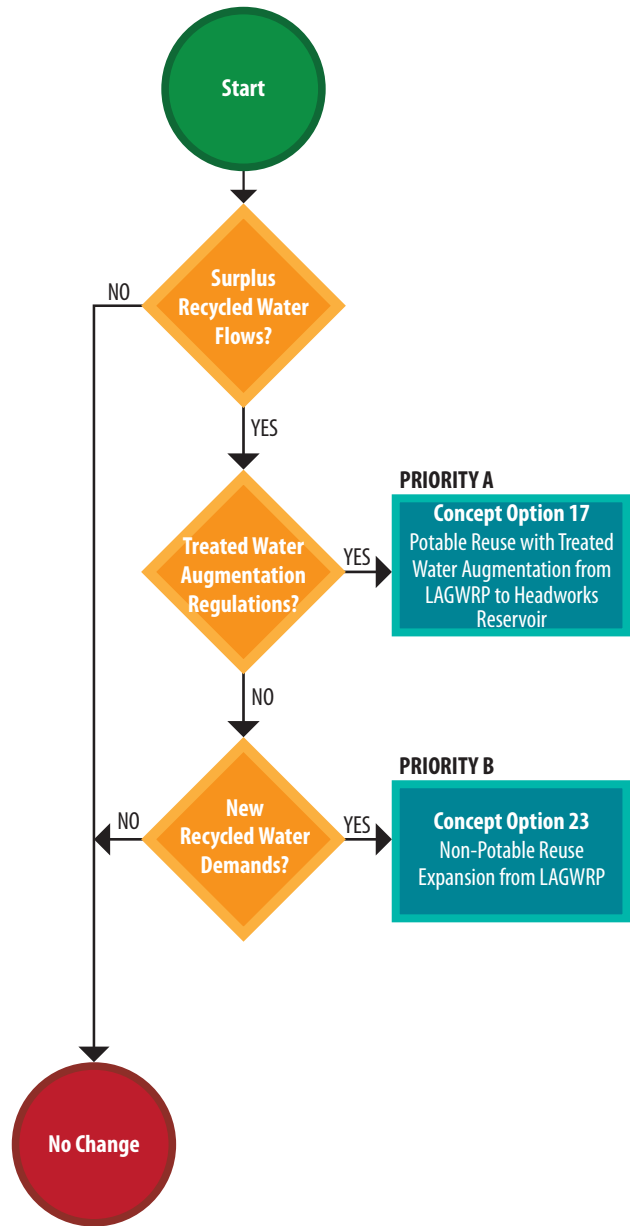

LEGEND & ACRONYMS

- ◆ Trigger
- Concept Option
- Flow Management Option

DCTWRP	Donald C. Tillman Water Reclamation Plant
GWR	Groundwater Replenishment Project
HWRP	Hyperion Water Reclamation Plant
LAGWRP	LA-Glendale Water Reclamation Plant
RWQCB	Regional Water Quality Control Board
TIWRP	Terminal Island Water Reclamation Plant
WRD	Water Replenishment District of Southern California

Disclaimer: At each trigger (decision point), evaluate all triggers and concept option priorities to consider changed circumstances in the future.

Figure 9.28
Trigger-Based Implementation Strategy for LAGWRP
One Water LA 2040 Plan
Summary Report

9.9.2.4 Implementation Strategy for the LA River

As shown on Figure 9.29, there are two concept options identified that involve storage and reuse of flows from the LA River. Based on the future integration opportunities analysis involving a comprehensive list of evaluation criteria, the concept options for the LA River were prioritized as follows:

- **Priority A: Concept Option #8B** – LA River recharge into the LA Forebay using dry wells within the riverbed
- **Priority B: Concept Option #8A** – LA River recharge into the LA Forebay using injection wells

It can be concluded that both concept options would recharge into the LA Forebay, which augments water supplies in the Central Basin. However, only Concept Option #8A would involve the installation of treatment facilities to treat LA River flows prior to injection. In addition, both concept options have the same assumed capacity of 15,000 AFY. This capacity is based on a conservative estimate of the available flow in this portion of the LA River.

As shown on Figure 9.29, the most critical trigger for both concept options is an institutional agreement with WRD, who acts as the Watermaster of Central Basin. In case such agreement does not materialize, neither concept option can be implemented. The next trigger is the potential need for approval of a water rights petition, in case this diversion does not fall directly under the City's pueblo water rights. The third trigger that needs to occur to allow implementation of Concept Option #8A (recharge with dry wells in the riverbed) is the approval of a Regional Water Quality Control Board Streambed Alteration Permit. In case the Regional Water Quality Control Board (RWQCB) does not approve this permit, the Priority B alternative, Concept Option #8A, could be implemented. This concept option would require a pump station, treatment facility, and injection wells to take recharge water from the LA River into the LA Forebay area. In case none of these three triggers materialize, it is recommended not to implement any project in this reach of the river. This decision is indicated as "No Change" on Figure 9.29.



However, there are two variations of another concept option developed for the LA River that is currently not included in the implementation strategy. These two variations of the eliminated LA River Concept Option #7 are:

- Upper LA River to the DCTWRP with the installation of a diversion structure upstream of Lake Balboa
- Upper LA River to the DCTWRP with the use of the Sepulveda Dam and rerouting of the LA River discharge point from Balboa Lake to downstream of the Sepulveda Dam

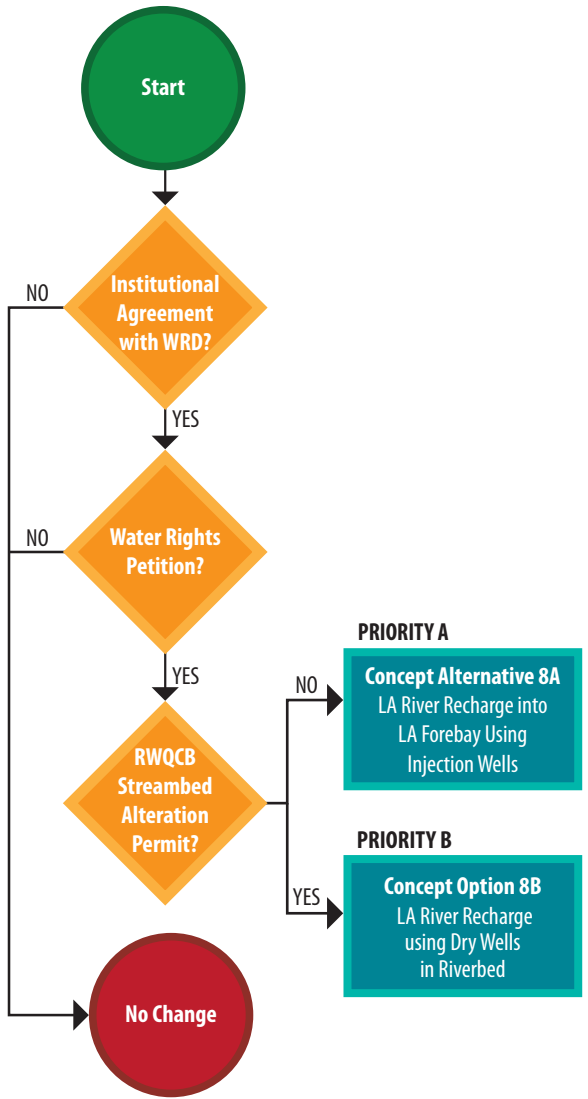
LA River Storage and Use



LEGEND & ACRONYMS

-  Trigger
-  Concept Option
-  Flow Management Option

DCTWRP Donald C. Tillman Water Reclamation Plant
 GWR Groundwater Replenishment Project
 HWRP Hyperion Water Reclamation Plant
 LAGWRP LA-Glendale Water Reclamation Plant
 RWQCB Regional Water Quality Control Board
 TIWRP Terminal Island Water Reclamation Plant
 WRD Water Replenishment District of Southern California

Disclaimer: At each trigger (decision point), evaluate all triggers and concept option priorities to consider changed circumstances in the future.

Figure 9.29
Trigger-Based Implementation
Strategy for LA River
 One Water LA 2040 Plan
 Summary Report

These two options are not included in the implementation strategy, because it was decided that utilization of flows downstream of the Area with Restoration Benefits and Opportunities for Revitalization (ARBOR) reach was preferred over projects upstream of this river segment due to the river restoration plans for the ARBOR reach. However, it may be desired to explore these options further if it would not be feasible to recharge the LA Forebay per Concept Options #8A or #8B.

As it is likely that the triggers, underlying conditions, and assumptions made for the development of these concept options will change in the future, it is recommended that City staff closely monitor all triggers and other circumstances that may impact the viability and prioritization of all concept options developed for the LA River. Future changed conditions may not only change the prioritization of the concept options included as Priorities A and B, but also impact the viability of the other LA River use options that are not included in the implementation strategy.

-This Page Left Blank Intentionally-

FUNDING NEEDS AND NEXT STEPS

Chapter 10 presents the various funding strategies that could be utilized to help finance the recommended projects, programs, and policies presented in the One Water LA 2040 Plan (Plan). The Chapter concludes with a discussion of the next steps beyond the completion of the Plan. These include the development of a Programmatic Environmental Impact Report (PEIR) to provide an overarching environmental document to support the Plan recommendations, as well as suggestions to promote continued collaboration, future Plan updates, trigger monitoring, and the associated progress reporting.

10.1 FUNDING NEEDS & RECOMMENDATIONS

As presented in Chapter 9 and summarized in Table 9.9, the total estimated cost of the projects and programs developed as part of the Plan is roughly \$13 billion. It is important to reiterate that the compilation of projects and programs included in the One Water LA 2040 Plan are not intended to provide a comprehensive city-wide CIP. Each City department still has many CIP projects that are solely related to their core responsibilities that do not require inter-departmental or inter-agency collaboration and are, therefore, not included in this Plan.

As a result, the baseline CIP of this Plan requires funding above and beyond the City's currently planned projects and O&M expenditures. When the total estimated cost of the baseline CIP is evenly distributed over the next 25 years, the \$13 billion of capital projects equates roughly to \$500 million per year in 2017 dollars, not including the additional O&M costs associated with these new projects. The stormwater improvement program alone is estimated to add another \$250 million annually by year 2040. To put these expenditures in perspective, the City has already invested \$500 million of Proposition O projects in the past 10 years, but would need to increase the annual expenditure rate significantly to meet the desired goals.

In addition to significant additional funding needs, the One Water LA baseline CIP would, therefore, also require an increase in labor resources to design, construct, and operate these new projects and facilities. As most of the stormwater improvement projects are required to be operational by certain compliance timeframes, both project funding and staffing needs (which also requires funding) are anticipated to increase significantly to meet water quality compliance requirements and avoid fines.

The majority of funds needed will likely compete for existing revenue first, thus impacting rates and potentially requiring higher annual rate increases in the future. Given the scope of the One Water LA 2040 Plan and the diversity of projects, it is recommended that a comprehensive funding plan be developed that includes the wide variety of existing and potential future funding sources summarized in Section 10.2. This comprehensive funding plan shall quantify the anticipated funding streams from utility rates, taxes, and/or fees supplemented by grants and loans to fund the baseline CIP.

Furthermore, many opportunities for alternative funding sources require matching funds. It is, therefore, critical that the City has sufficient additional revenue available to not only fund existing programs, but also provide matching funds for new projects to take advantage of many attractive grant and loan programs.

To address the funding needs of this Plan, ideas and recommendations were gathered throughout the Plan development from discussions between City staff and a wide range of Stakeholders. The recommendations related to funding include the following:

- Develop a comprehensive One Water LA Funding Plan.
- Explore stormwater tax or fee options.
- Increase use of State Revolving Funds for multi-benefit projects.
- Conduct rate studies every 3 to 5 years (versus LASAN's current 10-year rate cycle) to allow rate adjustments to account for changing conditions. For example, due to the success in water conservation in response to the drought, water consumption has decreased more than was assumed 10 years ago, resulting in reduced revenues. Or LASAN could continue to adopt rates for 10 years at a time, but revisit the analysis more frequently to assess the adequacy of rates, adjusting if necessary. For example, LASAN could set the base rates for 10 years to cover LASAN-specific costs and the expected One Water LA costs, but have a separate process in the three- to five-year timeframe to confirm that the rates are still sufficient and adjust if needed.
- Review and streamline the grant management structure and process, such as defining a strategy for grants (including vision, mission, goals, and metrics), updating the grant opportunities database monthly, providing front-funding and a cash-flow mechanism, assessing resource availability and defining responsibilities, developing a consistent project prioritization process for grant programs, and considering to offset resource constraints to write grants by outsourcing writing tasks to small businesses (e.g., MBE/WBE/OBE).
- Use or enter "take or pay" agreements with recycled water customers to avoid stranded assets in cases where LASAN debt finances capital projects.
- Understand how multiple agencies can and should contribute in identifying costs and benefits of water projects (e.g., LADWP pays for capital cost of recycled water treatment facilities and recovers capital and O&M costs through recycled water rates).
- Consider institutionalizing a "Joint Financing Authority" that has one funding entity but joint governance (separate from current organizational structures) to review and finance multi-benefit projects based on joint benefits, which could also be used to front fund grants.
- Follow pending legislation that assesses merging functions of sewer and stormwater.
- Highlight benefit-based funding to promote that multi-benefit projects are built and maintained, including considerations like environmental justice and enhancements in disadvantaged communities.
- Determine how to prioritize projects by measuring results and the value of benefits.
- Develop partnerships to reduce costs and maximize upstream solutions.
- Develop an integrated planning approach with the County and other cities.

Moving forward, these recommendations shall be reviewed and evaluated on a recurring basis by City staff tasked with the implementation of the One Water LA program recommendations.

10.2 POTENTIAL FUNDING SOURCES

Projects and programs that are recommended in the Plan could have access to diverse funding sources. For some of these funding sources, there are limitations or restrictions that could impact the availability of funding. Consequently, understanding which grants, loans, tax measures, and rate revenue sources are available to each of the participating City departments and regional entities provides the first step towards optimizing the use of the sources and selecting the appropriate funding approach.

Departments that are participating in the comprehensive One Water LA program planning process must also consider the investment of staff time required. Securing some funds requires a more involved application and role in the disbursement of funds, compared to others. Overall, participating departments and/or agencies must consider the return on the investment that each funding source might provide. The list of funding sources available to City departments and regional agencies provides a foundation to begin the selection process and approach to pursue the appropriate source. While this chapter outlines various funding sources, the most appropriate funding strategy for each project or initiative will need to be determined based on specific project attributes and the applicable partnering departments and/or agencies.

The funding sources include, but are not limited to the following:

- **Existing Utility Revenue** – Service charges collected from City of LA customers to recover the cost of providing water, wastewater treatment, recycled water, and stormwater management services.
- **Voter-Approved Tax Measures** – Statewide, regional, or city-imposed tax measures to fund government expenditures for specific purpose (e.g., transportation, water infrastructure, street improvements, etc.).
- **Grants and Loan Programs** – Federal, state, and local grant and loan programs. Each program should be reviewed to align project components with the funding program criteria and objectives. Note that competitive grants are not a process with any certainty and, thus, should be considered speculative in nature.
- **Partnerships** – In addition to single sources of funding, joint funding opportunities from both within the City and other entities will be considered. Other entities include, but are not limited to the following:
 - Regional partners such as Los Angeles County Flood Control District (LACFCD), MWDSC, LACSD, Los Angeles Unified School District (LAUSD), Metropolitan Transportation Authority (Metro), HSR, California Water Foundation, and the Water Research Foundation.
 - Partnerships with Non-Profits such as TreePeople, Heal the Bay, The River Project, Trust for Public Land, Surfrider Foundation, the Council for Watershed Health, The Nature Conservancy, and other similar organizations.

- Public private partnerships (P3) such as for the Central Los Angeles Recycling and Transfer Station (CLARTS) Organics Processing Facility, Tujunga well field Granular Activated Carbon, and Tire Recycling Program (TIRE).
- Private owners and volunteers.
- **Additional Alternatives** – Other funding sources, such as the general fund, incentives, utility fee discounts, and cap and trade systems, are described at a high level in TM 4.1 (Funding Strategies) in Volume 5.

A wide array of opportunities is available to the One Water LA participants to fund the identified capital improvements, project concepts, and program initiatives.

Funding sources available to City departments and regional agencies are summarized in the following sections and are described at a high level in TM 4.1 (Funding Strategies) in Volume 5. The various available funding sources specify different types of projects as potential recipients of funds. For example, the funding sources specific to stormwater are provided in greater detail in the Stormwater and Urban Runoff Facilities Plan (see Volume 3).

10.2.1 Existing Utility Revenues

Water and wastewater rates and charges recover costs for daily operations and capital infrastructure; however, certain limitations and restrictions apply. In 2006, the California Supreme Court ruled that the provisions of Proposition 218 apply to municipal rates (water, sewer, recycled water, and solid waste). This means that fees and charges are limited to the cost of providing the service and may not be imposed for general governmental services available to the public. In order for a project to be funded from rate revenues, a nexus must be created to show those paying for the service directly benefit.

While these revenue structures provide enhanced equity (those receiving the benefit pay for the service), the ability to fund large capital projects (through rates) is more limited. Often concerns of affordability and, as rate revenues are largely generated from usage, revenue volatility are expressed as potential funding shortcomings.

10.2.2 Voter-Approved Tax Measures

Aside from rates, the participating agencies also have at their disposal tax measures that can be applied statewide, regionally (e.g., within a specific watershed), or across the benefitting service district or municipality. These measures generate revenue that is dedicated to a specific purpose.

10.2.2.1 Statewide Tax or Bond Measures

Statewide tax measures can raise a substantial amount of revenue. Unlike rates or other sources, they are not restricted for use (beyond the language of the measure), they carry advantageous interest rates, and the money is secure. Statewide tax measures, however, exhibit significant lag times between each step of a project's funding process, from the identification of the need to the inclusion of the tax measure on the ballot to the collection of revenues. Additionally, statewide tax measures require major upfront investments in order to garner support.

If the State opts to issue additional revenue bonds, however, the City would be required to apply for and be awarded funds for projects, which may or may not happen.

10.2.2.2 Regional/Watershed/County Tax Measures

Agencies can pass local or regional tax measures in order to fund some of the projects identified as part of One Water LA. While the scope of the regional tax measure is smaller than that of a statewide measure, it still requires the support and coordination of multiple stakeholders. This may or may not pose a delay or obstacle in the passing of the measure.

In November 2016, City voters approved Measure A and Measure M, two important programs that were assumed to provide future funding for essential stormwater management program costs. They are described below.

Measure A

Measure A is a Los Angeles County measure passed in November 2016 that authorizes general obligation bonds for construction of new parks and open space, and includes project elements to improve stormwater management in those projects. LASAN has developed several strong partnerships with the Los Angeles County Department of Parks and Recreation (LACDPR) and Los Angeles Department of Recreation and Parks (RAP) where recreational benefits, open space values and stormwater quality improvement were all realized in multi-benefit projects.

Measure M

Measure M is a countywide sales tax surcharge that will fund improvements to the transportation system in the County. Many of these projects will benefit the City's stormwater compliance obligations, because existing transportation rights-of-way are significant portions of the impervious surface area within the City, and the development of new transportation facilities will comply with the City's low impact development (LID) ordinance.

Countywide Special Tax

A potential future revenue source can also be the countywide special tax. Los Angeles County Board of Supervisors is considering a countywide special tax on properties that would help fund additional stormwater capture and management projects. The details of the proposal are still being developed, and the City of Los Angeles is coordinating with LA County and contributing to the development of the proposal.

10.2.3 Grants and Loan Programs

Outside of direct funding measures (rates or taxes), there is an opportunity to utilize federal or state grant or loan programs. The existing grants and loan programs are summarized in Table 10.1, while brief descriptions are provided in the following subsections. A more detailed discussion of all funding strategies is included in TM 4.1 (see Volume 7).

Table 10.1 Available Loan and Grant Funds Summary Report One Water LA 2040 Plan				
Providing Agency	Source of Funds	Program Name	Purpose of Program	Grant/Loan Terms
Bureau of Reclamation	Title XVI	WaterSMART	Reclaim impaired groundwater sources	Grants for studies, <\$5M
Bureau of Reclamation	Water Infrastructure Finance and Innovation Act	Water Infrastructure Finance and Innovation Act	Construct stormwater and wastewater infrastructure	Loans for up to 49%, >\$10M
State Water Resources Control Board		Clean Water State Revolving Fund	Construct water reclamation facilities	Loans for up to 100% of construction, no cap
State Water Resources Control Board	Proposition 1	Proposition 1 Stormwater Grant Program	Support multi-benefit stormwater management	Construction grants for up to 50%, <\$10M
State Water Resources Control Board		Water Recycling Funding Program	Augment or offset water supply	Grants and loans for up to 35%, <\$15M
California Infrastructure and Economic Development Bank		Infrastructure State Revolving Fund	Sewage treatment and flood control	Loans for <\$25M
California State Resources Agency	Proposition 1B	Environmental Enhancement and Mitigation Program	Mitigate environmental effects of transportation	Construction grants <\$500,000
California Air Resources Board	Cap-and-trade permit auctions	Cap-and-Trade	Energy efficiency, waste diversion	Unknown
LA County Propositions A & C	Half-cent sales tax supporting revenue bond	Propositions A & C	Water quality and roadway efficiency	<\$10M
City of LA Proposition O	1% property tax increase		Remove pollutants from local waterways and ocean	

In the cases of grants or revolving fund loans, when the benefits of certain types of projects fall under the purview or service area of either LADWP, LASAN, the City of LA, or LACFCD, the responsible agency becomes the applicant for the grant or loan. When projects that could be funded by grants provide a benefit to multiple agencies, the agency that is most well-suited to handle the application process would assume the application responsibilities.

As each potential funding opportunity involves a commitment of limited staff and resources, it is important for each agency to determine whether the potential funding available is reasonable for the level of effort.

10.2.3.1 Clean Water State Revolving Fund Loans

Clean Water State Revolving Fund (CWSRF) loans are administered by either states or the Environmental Protection Agency (EPA) in a federal-state partnership. The California CWSRF is administered by the California Water Resources Control Board. The funds provide low-interest loans to finance eligible projects.

The loans have an extremely advantageous interest rate and repayment terms. The funds can be used to support sewer or stormwater projects. However, these funds are limited and are currently highly subscribed. The CWSRF loans cannot be used on drinking water projects.

10.2.3.2 Drinking Water State Revolving Fund Loans

Drinking Water State Revolving Fund (DWSRF) loans provide low-interest loans and are also administered by the EPA in a federal-state partnership or by individual states. DWSRF loans also offer extremely advantageous interest rates and repayment terms. Additionally, they may provide repayment or forgiveness policies for disadvantaged communities.

10.2.3.3 Other Low-Interest Loans

Other federal and state departments have appropriated funds to administer to public agencies as low-interest loans. The potential low-interest loans available to the participating agencies of One Water LA include the Water Infrastructure Finance and Innovation Act loans and the California Infrastructure and Economic Development Bank Infrastructure State Revolving Fund loans.

10.2.3.4 Federal Grants

Various federal agencies administrate federal grants to assist local agencies to implement large-scale infrastructure projects. Two federal grants that may assist the City in delivering the SIP are described below.

Water Infrastructure Improvements for the Nation Act

The Water Infrastructure Improvement for the Nation Act (WIIN) was enacted in December 2016. Federal appropriations under the WIIN may offer federal subsidies for stormwater projects and/or offer matching funds for revenue pledges from City sources.

Community Development Block Grant

The Community Development Block Grant (CDBG) program has been administered by the U.S. Department of Housing and Urban Development (HUD) since 1974. The program focuses on development of affordable housing, suitable living environments, and jobs through expanding and retaining businesses for disadvantaged communities. In addition to providing funding to housing-related activities, the program also funds projects that are related to planning, construction, reconstruction, or installation of water and sewer facilities, including storm sewers through its

Entitlement Program. This program is limited to funding capital costs, not operations and maintenance expenses.

10.2.3.5 State Grants

State Bond monies authorized by voters for water-supply improvements may also offer grant monies for stormwater projects, and those sources should be further pursued. The City has developed applications that are pending and may have additional opportunities to apply for grants under these voter-approved bonds.

In California, three voter-approved propositions could provide grant funding opportunities for stormwater- and flood-control-related projects. These Propositions are Proposition 1E: Disaster Preparedness and Flood Protection Bond Act; Proposition 84: Safe Drinking Water, Water Quality and Supply, Flood Control, River and Coastal Protection Bond Act; and Proposition 1: Water Quality, Supply, and Infrastructure Improvement Act.

Propositions 1E and 84

Both Propositions 1E and 84 were approved by voters in 2006, with the former focusing on rebuilding and repairing flood control structures, while the latter focused on a wide range of projects, including safe drinking water, water quality and supply, flood control, waterway and natural resource protection, water pollution and contamination control, state and local park improvements, public access to natural resources, and water conservation efforts. Given the age of Propositions 84 and 1E, the majority of authorized funding has already been committed or spent. It is anticipated that funding opportunities from Propositions 84 and 1E available for the City would be very limited. According to the Allocation Balance Report published by the California Natural Resources Agency, the non-committed allocation balances for Proposition 84 and Proposition 1E were \$132 million as of August 6, 2016, and \$34 million as of July 16, 2016, respectively.

Proposition 1

Proposition 1, which was approved by voters in 2014, is the latest and most important grant program for water infrastructure in California. The total allocation of Proposition 1 is \$7.5 billion and is intended to fund investments in water projects and programs. The bond funds will be distributed through a competitive grant process overseen by various state agencies, including the DWR and the SWRCB. Competition for these grant funds is fierce, which serves to limit access for stormwater purposes.

10.2.4 Partnerships

Partnerships can also help fund water-resilient-type projects by leveraging resources between each of the agencies involved. The agencies can include City departments, regional agencies, non-profit organizations, and private agencies.

10.2.4.1 Interdepartmental and Regional Partnerships

Some of the existing stormwater and wastewater projects developed by the City have been completed due to inter-departmental and regional partnerships. For example, stormwater capture

projects that can provide water supply benefits to the City are funded by both LASAN and LADWP. This includes both capital and operations and maintenance cost (e.g., LADWP could pay for the capital costs and LASAN could pay for the O&M, depending on the situation, per the City Charter and respective department missions).

10.2.4.2 Public/Private Partnerships

Public/Private Partnerships (P3s) are cooperative arrangements between public and private parties to construct, finance, and/or operate facilities on behalf of the public agency. Private parties can also include non-profit organizations. Arrangements for P3s are often used for large-scale transportation projects and are used by municipal agency activities, such as ambulance and first-response services. The uses of P3s for large-scale municipal water and wastewater projects is not as common, but many agencies throughout the United States contract out operations and enter into solar power agreements. Most recently, the San Diego County Water Authority entered into an agreement with Poseidon Water for the production and delivery of desalinated water. This model is currently being explored in other locations in Southern California.

10.2.4.3 Joint Powers Authority

A Joint Powers Authority (JPA) is a partnership between two or more municipal agencies that may jointly exercise any power common to all of them. JPAs are common in California and are used to jointly fund and operate single projects, such as a recycled water facility, or a regional program, such as the Santa Ana Regional Interceptor in San Bernardino and Riverside Counties.

With respect to One Water LA, a local JPA could include LASAN, LADWP, and other agencies. After formation, the JPA and subsequent operating agreements would define the responsibilities including payments for expenditures such as debt service and operating costs. A large project, or project group, would likely require its own specific JPA to define the responsibilities of member agencies (e.g., funding requirements). The JPA may independently issue debt services to fund the project if authorized by the participating agencies.

10.2.4.4 Volunteerism

Partnerships with community volunteers and private owners can also help provide great benefits to the City. The City of Los Angeles, local non-profit organizations, and businesses offer a number of specialized volunteering programs that enhance the City's environment and community development. The volunteering programs also provide an educational benefit for the community on stormwater, water quality, and water supply related issues. While the quantitative value of volunteerism is still being evaluated, there is no doubt that volunteerism serves as a valuable resource for the City.

10.2.5 Additional Alternatives

While the previously explored funding alternatives outlined above are conventional methods (rates, taxes, loans/grants), various additional alternatives are:

- Cap-and-Trade Systems
- Utility Fee Discounts

- Rebate Incentives
- Low-Interest Loan Programs
- General Fund
- Funding for Water Supply Benefits

Further discussion is provided in TM 4.1 (Funding Strategies), see Volume 5, and the Stormwater Facilities Plan, see Volume 3. Again, none of these alternatives are mutually exclusive and can be explored depending on available staffing and resources.

10.2.6 Funding and Cost-Sharing Methodologies

Central to a funding strategy is a discussion of how programs shall be funded by participating agencies. Because participation in One Water LA is voluntary and each department/agency has differing priorities with limited funding, impacts to all relevant CIPs should be considered in assessing feasibility of these projects prior to implementation.

Due to the integrated nature and regional benefit of the projects identified through One Water LA, it is anticipated that there will be many secondary and indirect beneficiaries of this program. Any agency that chooses to receive a benefit and would like to participate in the project may nor may not be allocated project costs based on their share of the project benefits. The contributions by each participating party shall be determined on a project- or program-specific basis. These contributions shall be based on a number of factors, including benefits and ability to access funding. For secondary or general benefits, such as open space, which are likely to occur without the ability to allocate costs to, or collect funds from beneficiaries, the City's General Fund and other discretionary funding sources may be pursued. Cost-sharing agreements between departments and/or agencies require a process that should consider a number of factors, including:

- Benefits to the respective agency.
- Other secondary partner agencies that might also benefit from the project, either directly or indirectly.
- Ability to participate in and fund their respective share of the program.

In the initial planning stages of a project, the participating agencies can use a consistent approach to determine the preliminary funding strategy. However, as all projects are unique, there is no set approach to determine the optimal allocation of the funding responsibilities; the cost-sharing process shall involve a discussion of each of the above factors.

As part of the Plan development, a series of Special Topics Group (STG) meetings were held for five specific topics. One of these topics was "Funding Strategies." During the four Funding Strategies STG meetings, a concern was raised that the cost responsibility could be shifted to agencies that have the ability to fund a given project rather than those agencies that most directly benefit from the project. However, the STG participants acknowledged that direct beneficiaries of a specific project or program should fund a proportional share of the costs. The following strategy was developed and recommended by the STG to implement a repeatable and transparent plan for each program or a specific project. The defined process consists of four steps for each program (see Figure 10.1).

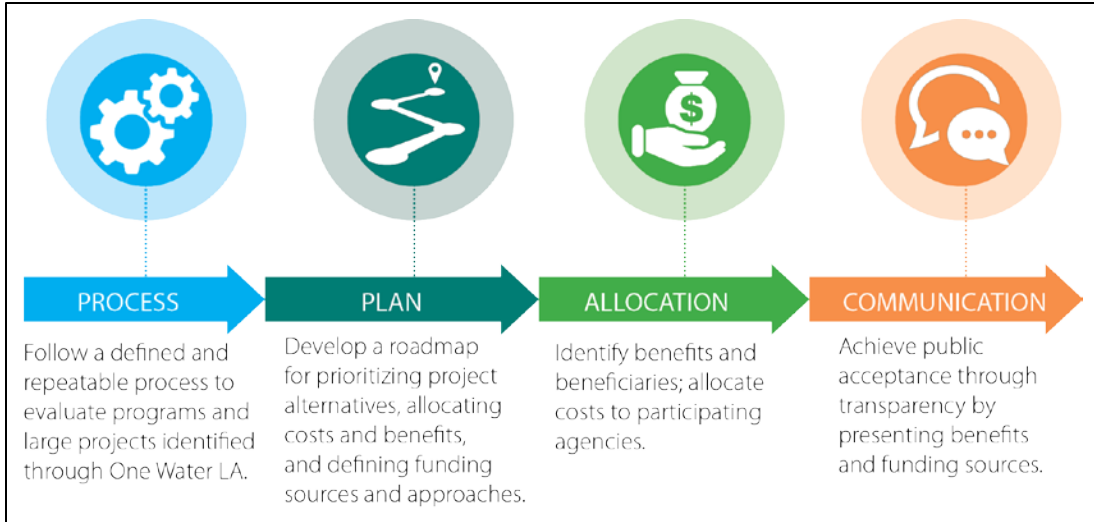

Figure 10.1 Cost-Sharing Strategy

It was concluded that the allocation of costs should be performed at the time that a program or project is brought forward for consideration. Fundamental to this cost allocation is to consider both qualitative and quantitative factors.

For example, a common quantitative factor is a total cost of production per acre-feet of water produced. An example of a qualitative factor that can be considered is the creation of additional recreational space. The City and its partners, including many noteworthy nonprofit organizations, have made great strides to quantify or monetize the benefit of these otherwise qualitative factors, such as in the Bureau of Reclamation Los Angeles Basin Stormwater Conservation Study. This work provides a strong foundation to conduct any future cost-benefit analysis but has been primarily focused on stormwater projects.

The following components were identified to prepare a high-level description of how cost allocations and cost benefits could be applied to multi-benefit and multi-party projects:

- **Multi-Benefit Project** – A multi-departmental and/or multi-agency integration opportunity (project or program) that has been identified by multiple parties and has multiple benefits.
- **Primary and Secondary Parties** – The primary party would be the lead of the project. The secondary party could be more than one agency or department.
- **Cost** – Costs can be borne by primary and secondary parties, and separate parties may be responsible for individual cost components (capital, operating, maintenance).
- **Benefits** – Multiple benefits split between quantitative and qualitative measures. These benefits are global benefits and not those specifically attributable to the primary or secondary parties. It is important to note that many qualitative benefits may become quantitative benefits as more data becomes available. Many federal and state agencies have developed studies that can identify a quantitative value to various types of benefits (e.g., health and safety, air quality, community development, etc.)

The quantitative and qualitative effects of municipal projects can be categorized as economic, financial, environmental, or social. These effects are briefly summarized below:

1. **Economic effects** include the benefits associated with different types of goods and services supported by the management concepts, the costs of different concepts, the impacts of different concepts on the regional economy through changes in the amount and type of spending, and the cost-effectiveness of different concepts.
2. **Financial effects** include the impacts on water utility revenues and expenditures, impacts on utility bills, fiscal impacts on state and local governments, and the ability of water users to pay for different concepts.
3. **Environmental effects** reflect the type and quality of environmental and natural resources that would be potentially influenced by a concept. Environmental effects would include items such as water quality, energy consumption, impacts on habitat, and ecosystem function.
4. **Social effects** reflect the social characteristics of a community or region. Examples of social effects include education, environmental justice, and quality of life.

The allocation of project costs among the agencies involves a number of factors and will always be determined on a case-by-case basis.

10.3 NEXT STEPS

The One Water LA 2040 Plan is intended to be more than a plan – it's a comprehensive strategy for managing water in an integrated way to achieve the One Water LA Vision, which is defined as:

One Water LA is a collaborative approach to develop an integrated framework for managing the City's water resources, watersheds, and water facilities in an environmentally, economically, and socially beneficial manner.

One Water LA will lead to smarter land use practices, healthier watersheds, greater reliability of our water and wastewater systems, increased efficiency, and operation of our utilities, enhanced livable communities, resilience against climate change, and protection of public health.

The City will undertake a number of immediate and near-term steps to start implementing the findings and recommendations presented in the Plan. These steps are described below and include the following:

1. Prepare a Programmatic Environmental Impact Report (PEIR).
2. Continue Inter-Departmental Collaboration and Coordination.
3. Continue Stakeholder Engagement and Public Outreach.
4. Further assess and develop policies and programs.
5. Pursue funding strategies to implement the Plan.
6. Complete Future One Water LA Plan Updates and Reporting.

These activities are critical to One Water LA's success, identifying multi-departmental and multi-agency integration opportunities to efficiently, cost-effectively, and sustainably manage water. The One Water LA 2040 Plan represents the City's continued and improved commitment to collaboration and integrated management of all its water resources and implementation of innovative solutions. The Plan will help guide future strategic decisions when prioritizing and implementing integrated water, wastewater, and stormwater infrastructure projects, programs, and policies within the City.



Figure 10.2 Adel Hagekhalil (LASAN's Assistant Director) and Marty Adams (LADWP's Chief Operating Officer) led the regional collaboration at a VerdeExchange Water Charette (June, 2017)

10.3.1 Programmatic Environmental Impact Report

This section is intended as a placeholder to describe the Programmatic Environmental Impact Report (PEIR) planning process, including the stakeholder outreach that will be conducted by the City. In addition, the key environmental concerns and associated mitigation measures that were identified during the PEIR process will be summarized in this section in the future. The PEIR report will be included in Volume 10.

The City intends to prepare a comprehensive PEIR for the entire One Water LA 2040 Plan beginning in 2018. This PEIR will be conducted pursuant to the requirements defined by the California Environmental Quality Act (CEQA). The purpose of the PEIR is to obtain an overarching environmental document that assesses the potential environmental impacts that could result from implementation of the Plan recommendations. The PEIR will also identify appropriate mitigation measures and alternatives that could reduce potential negative environmental impacts. Per CEQA, the PEIR needs to be prepared with input from public stakeholders at certain milestones and with specific minimum review times for public comments. The City needs to provide responses to all public comments on the Draft and Final Draft PEIR documents in order to finalize the PEIR. Based on the type of public comments received, the Final Draft Plan will likely need to be modified to prepare the Final One Water LA 2040 Plan. City Council can then also adopt the Final One Water LA 2040 Plan in a separate or the same session as the adoption of the Final PEIR.

10.3.2 Continued Inter-Departmental Collaboration & Coordination

One of the primary goals for One Water LA is to continually build and expand collaboration and coordination between City departments, regional agencies, and a wide variety of stakeholders. This comprehensive collaboration process started with the development of the 2006 Water Integrated Resources Plan (Water IRP) and continued during the past decade.

A few specific future coordination and collaboration activities that are currently identified are discussed in the following subsections.

10.3.2.1 Inter-Departmental and Inter-Agency Coordination

When Phase 1 of One Water LA was initiated in late 2013, a Steering Committee was formed. This Steering Committee includes representation of 14 different City departments and 6 regional agencies. With the input of the Steering Committee members and other stakeholders, the One Water LA 2040 Plan provides the roadmap for City departments and regional agencies to find new ways to integrate and implement their respective practices and services. Coordination on water-related projects and programs not only achieves the individual missions of City departments and regional agencies, it also provides multiple benefits to the City to address its water management challenges.

Moving forward, the One Water LA team will continue engagement of City departments and regional agencies that participated in the Steering Committee by establishing an Inter-Departmental and Agency Committee. The participants and meeting frequency of this Inter-Departmental and Agency Committee will be determined in the near future. The main mission of the committee is to coordinate and discuss matters related to the implementation of the Plan recommendations, such as institutional agreements, and cost-sharing. Implementation strategies will be discussed as a sub-set of this committee in order to track progress, monitor triggers, reprioritize, and implement the recommendations made in this Plan.

Additionally, departments and agencies will remain engaged in other committees and workgroups and continued one-on-one focus meetings between the One Water LA Team and individual departments and agencies to advance integration of water-related efforts.

A list of potential topics for committees and/or workgroups is included in Section 10.3.2.3.

10.3.2.2 Continued Stakeholder Engagement and Public Outreach

As described in Chapter 2, the One Water LA 2040 Plan was developed with extensive stakeholder input. In addition to the One Water LA Stakeholder Group, which was merged with the Recycled Water Advisory Group, the planning process included a large number of special topics group meetings, Advisory Group meetings, stakeholder workshops, and informational stakeholder meetings. Some examples of specific input received during the Plan development includes the development of the One Water LA Objectives and Guiding Principles in Phase 1, development of evaluation criteria and weighting factors for the ranking of concept options, and prioritization of water management strategies. The stakeholder-driven process has contributed a wide range of perspectives that were integrated in the Final One Water LA 2040 Plan.

Moving forward, the One Water LA team will continue stakeholder engagement through:

- Continuing Stakeholder Meetings,
- Engaging stakeholders in committees and workgroups (listed in Section 10.3.2.3) as appropriate,
- Enlisting technical experts on specific topics,
- Continuing progress updates via meetings, email communications, website, and social media, and
- Continuing presentations at neighborhood council meetings and community events

10.3.2.3 Committees and Workgroups to Advance One Water LA Plan Implementation

Moving forward, the City intends to continue to engage the respective departments, agencies, and One Water LA Stakeholders through the establishment of implementation committees and/or workgroups.

The exact composition of and tasks for each committee is yet to be determined. Some initial examples of potential topic areas and possible activities include:

- **Policies and Programs** – Refinement of policy ideas and language, and input on feasibility analysis of certain policies.
- **Streamlining of Operations and Maintenance** – Identification and quantification of O&M needs for categories of or specific projects, templates for institutional agreements, and evaluation of potential City programs.
- **Funding, Cost-Sharing, and Partnerships** – Streamlining pursuit of funding options for programs and projects recommended through One Water LA , and input on available tools to support a benefit-based cost sharing approach, etc.
- **Database Coordination** – Input in development of GIS based "One Water" project portal and coordination of existing datasets/databases.

These are just four examples of potential Technical Topic Committees. The One Water LA Inter-Departmental and Agency Committee will identify other technical areas that may benefit from a Technical Topic Committee. It should be noted that the Technical Topic Committees differ from the Special Topic Groups because of the focus on Plan implementation rather than Plan development. It is also anticipated that these Technical Topic Committees would involve a continuous time commitment over a longer period of time, possibly a few years versus a few months.

10.3.3 Future One Water LA Plan Updates and Reporting

The One Water LA team will work with the Inter-Departmental and Agency Committee described in Section 10.3.2.1 to prepare annual progress reports, as well as presentations for the City's Water Cabinet on an as-needed basis. The purpose of the annual One Water LA Progress Report is to communicate the progress made since the completion of the Plan with executive management of LASAN and LADWP, other City departments, regional agencies, and the One Water LA stakeholder group. This annual progress report is intended to be brief and easy to read, preferably with a high graphic and photo content to quickly communicate accomplishments with the audience. Although the content and organization of the annual progress reports will be determined during the first update, each progress report could, for example, include:

- Key accomplishments toward achieving each of the One Water LA Objectives and Guiding Principles
- Status summary of current and future integration opportunities
- Status summary of stormwater and wastewater projects
- Trigger status update and associated implications for the recommended current and future integration opportunities (an example of a Trigger Tracking Form is shown on Figure 10.3)
- Status of actions associated with the prioritized policies and programs
- Short-term goals for the upcoming (fiscal) year
- Summary of outreach and stakeholder engagement activities

In addition to the annual brochure-style progress report updates, it is recommended that this Plan be updated every 5 or 10 years. This Plan Update frequency maintains a sufficient level of accuracy, as the conditions on our urban water landscape tend to change quite fast. By updating critical information in the Plan every five years, the entire plan provides a better foundation for other planning efforts in the City. Examples of critical information include, but are not limited to, flows, demands, regulatory conditions, status of planned and in-progress projects, trigger status, and project cost estimates. It is recommended that annual updates follow the completion of future UWMPs, which must be prepared every five years, to keep the demand and water supply forecasts of these two documents consistent and coordinated.

Lastly, it is recommended that the One Water LA team prepare announcements, project write-ups, short stories, and other updates to share with the One Water LA stakeholders. Keeping the One Water LA stakeholders informed about Plan implementation progress, will encourage many of these diverse and knowledgeable Plan participants to be re-engaged during the One Water LA Plan Update.

TRIGGER TRACKING FORM

Meeting Date:

Meeting Participants:



Trigger Category	Trigger Description	Status Change? (Y/N)	Action Desired? (Y/N)	Trigger Dependent Projects & Integration Opportunities	Discussion Comments & Action Items
Asset Condition	Wastewater system asset condition				
	Stormwater system asset condition				
Climate Risk & Resilience	Future prolonged droughts				
	Changes in size of peak storm event				
	Changes in frequency of peak storm events				
Demands & Flows	Sea level rise				
	Decreased supply availability & reliability				
	Increase in recycled water demands				
	Increased conservation				
Institutional Agreements	Decreased conservation				
	Water exchange agreements between X and Y				
	Cost Sharing Agreements between X and Y				
Regulations	O&M Agreements between X and Y				
	Compliance deadlines of existing TMDL limits				
	Approval of a wastewater change petition				
	Potable Reuse Regs with Raw Water Augmentation				
	Potable Reuse Regs with Treated Water Augmentation				
	Toxicity limit in a receiving water body is reached				
	Future TMDL limits for new pollutants				
More stringent WRP discharge requirements					

Figure 10.3 - Example of a Trigger Tracking Form
One Water LA 2040 Plan
Summary Report



-This Page Left Blank Intentionally-

APPENDIX A – REFERENCES

- American Society of Civil Engineers (ASCE), 2014. *Flood Resistant Design and Construction*. ASCE/SEI 24-14. 2014.
- ARCADIS, 2017 – Arcadis, East West Valley Interceptor Sewer (EWVIS) Concept Report prepared for Los Angeles Bureau of Sanitation, January 2017. Ballona Creek Watershed Management Group, 2015, *Enhanced Watershed Management Program for the Ballona Creek Watershed*, June 2015.
- Barnard, P. L., van Ormondt, M., Erikson, L.H., Eshleman, J., Hapke, C., Ruggiero, P., Adams, P. N., and Foxgrover, A. C. 2014. *Development of the Coastal Storm Modeling System (CoSMoS) for Predicting the Impact of Storms on High-Energy, Active-Margin Coasts*. Natural Hazards, 31 p., doi:10.1007/s11069-014-1236-y.
- Battelle Memorial Institute, Final Independent External Peer Review Report Los Angeles River Ecosystem Restoration Feasibility Study, Draft Integrated Feasibility Report and Environmental Impact Statement, November 2013
- BCWMG, 2015. Ballona Creek Watershed Management Group, 2015, *Enhanced Watershed Management Program for the Ballona Creek Watershed*, June 2015.
- Berg, N., Hall, A., Sun, F., Capps, S., Walton, D., Langenbrunner, B., and Neelin, D. 2015. *Twenty-First-Century Precipitation Changes over the Los Angeles Region*. Journal of Climate, 28.
- Black & Veatch Corporation (2010) *White's Handbook of Chlorination and Alternative Disinfectants*, 5th Edition, John Wiley & Sons, Inc., Hoboken, New Jersey.
- Black & Veatch, 2015. *Draft Benedict Canyon Harvesting and Beneficial Reuse Project Draft Concept Development Report*. May 2015.
- Board, L.A. (2014, September 11). Table 2-1. Beneficial Uses of Inland Surface Waters. Retrieved from LARWQCB: http://www.waterboards.ca.gov/losangeles/water_issues/programs/basin_plan/electronics_documents/BeneficialUseTables.pdf
- Borrero, Jose C., Mark R. Legg, and Costas E. Synolakis, 2004. *Tsunami Sources in the Southern California Bight*. Geophysical Research Letters, Vol. 31, L13211. Doi:10.1029/2004GL020078, 2004.
- Brekke et al. 2013. Downscaled CMIP3 and CMIP5 Climate Projections Release of Downscaled CMIP5 Climate Projections, Comparison with Preceding Information, and Summary of User Needs.
- Bureau of Reclamation (Reclamation). 2013. Downscaled CMIP3 and CMIP5 Climate Projections. Release of Downscaled CMIP5 Climate Projections, Comparison with Preceding Information, and Summary of User Needs.

- Bureau of Reclamation, *Los Angeles Basin Stormwater Conservation Study Task 5 - Infrastructure & Operations Concepts Report*, December 2015. Prepared by CH2M Hill.
- Bureau of Reclamation, *Los Angeles Basin Stormwater Conservation Study Task 6 - Trade-Off Analysis & Opportunities*, January 2016.
- BWSC. 2015. *Wastewater and Storm Drainage System Facilities Plan*. Prepared by CH2M for the Boston Water and Sewerage Commission, Boston, MA. June, 1015.
- CADWR. 2015. California Department of Water Resources *California Irrigation Management Information System (CIMIS)*. Available: <http://www.cimis.water.ca.gov/Default.aspx>.
- California Code of Regulations, Title 22, Division 4.
- California Department of Water Resources (CDWR). *Coastal Plain of Los Angeles County Groundwater Basin, West Coast Subbasin*. California's Groundwater. Bulletin 118.
- California Department of Water Resources Climate Change Technical Advisory Group (CCTAG). 2015. *Perspectives and Guidance for Climate Change Analysis*. California Department of Water Resources Technical Information Record. p. 142.
- California Regional Water Quality Control Board Los Angeles Region, *Water Quality Control Plan Los Angeles Region*, June 1994
- California RWQCB Los Angeles Region and U.S. EPA Region 9, *Dominguez Channel and Greater Los Angeles and Long Beach Waters Toxic Pollutants Total Maximum Daily Loads*, 2011.
- California, Resources Agency, Department of Fish and Game. Sacramento, CA. 166 pp.
- Carollo Engineers, 2016. *Rancho Park Concept Report*. (Final Draft). September.
- Carollo Engineers, 2016. *Special Study Task 12D - LA River Flow Study Summary Report (DRAFT)*. One Water LA 2040 Plan. September.
- Carollo Engineers, 2016. *TM 1.2 – Existing Flow Conditions* (Final Draft). One Water LA 2040 Plan. June.
- Carollo Engineers, 2016. *TM 1.3 – Existing Water Projects and Programs* (Final Draft). One Water LA Plan. January.
- Carollo Engineers, 2016. *TM 2.1 – Future Flow Conditions* (Final Draft). One Water LA 2040 Plan. June.
- Carollo Engineers, 2016. *TM 3.1 – Near-Term Integration Opportunities*. Case Study Selection. (Final). November.
- Carollo. 2014. *Satellite Wastewater Treatment Plant Feasibility Study, Alternatives for Implementing Satellite Treatment Facilities*. October 2014.

- Carollo. 2015. *Satellite Wastewater Treatment Plant Feasibility Study, Case Study: Satellite Treatment Facility at the UCLA Campus*. July 2015.
- Cayan, D.R., M. Tyree, M. Dettinger, H. Hidalgo, T. Das, E.P. Maurer, P. Bromirski, N. Graham, and R. Flick. 2009. *Climate Change Scenarios and Sea Level Rise Estimates for the California 2008 Climate Change Scenarios Assessment*.
- CCI and Penn State. 1999. *Delivery System Study*.
- CDM:CH2M, 2015. CDM Smith and CH2M, *One Water LA Phase 1 - Initial Water Balance, Draft Technical Memorandum*, July 2015.
- CH:CDM, Phase II City of Los Angeles Integrated Resources Plan for the Waste Water Program – Los Angeles River Recycled Water Evaluation Study Phase 1 Baseline Study, January 2005
- CH2M, TM 5.5 Climate Risk and Resilience Assessment for Infrastructure, May 2017 (One Water LA 2040 project).
- CH2M. 2012. *Technical Memorandum No. 1, Analysis of Projected Changes in Precipitation IDF Values Based on Climate Change Projections*. Prepared by CH2M for the City of Los Angeles Bureau of Sanitation. May 15, 2012.
- City and County of San Francisco. 2016. *The Sea Level Rise Action Plan*. Prepared by AECOM, CH2M and Risk Management Solutions for San Francisco Planning and San Francisco Public Works. March, 2016.
- City of Los Angeles – Mayor’s Office, 2015. *Sustainability pLAN*. April.
- City of Los Angeles – Mayor's Office, 2014. *Executive Direction #5 – Emergency Drought Response, Creating a Water Wise City*. October 14.
- City of Los Angeles Clean Water Program, *Wastewater Capital Improvement Program Project Descriptions and 10-Year Expenditure Plan (Fiscal Years 2015/16 - 2024/25)*.
- City of Los Angeles et. al., 2015. *Santa Monica Bay Jurisdictional Group 2 and 3 Enhanced Watershed Management Program*.
- City of Los Angeles, 2006, *Integrated Resources Plan*.
- City of Los Angeles, 2007, *Los Angeles River Revitalization Plan*, April 2007.
- City of Los Angeles, 2009. *Machado Lake Ecosystem Rehabilitation Project and Wilmington Drain Multi-Use project Final Pre-Design Report*. July 2009.
- City of Los Angeles, 2011. *Stormwater LID Ordinance*. November 14, 2011; last updated May 9, 2016.
- City of Los Angeles, 2014, *Executive Directive No. 5: Emergency Drought Response: Creating a Water Wise City*.
- City of Los Angeles, 2015, *OneWater LA 2040 Plan Guiding Principles Report*, May 4, 2015.

- City of Los Angeles, 2016. Planning and Land Development Handbook for Low Impact Development (LID). May 5. On the web at: <http://www.lastormwater.org/green-la/low-impact-development/lid-documents/>
- County of Los Angeles, 2004. LA County Department of Public Works, Sun Valley Watershed Management Plan, May 2004.
- County of Los Angeles, 1996. LA County Department of Public Works, Los Angeles River Master Plan, June 1996.
- County of Los Angeles et. al., 2015, Marina del Rey Enhanced Watershed Management Plan.
- Culp, G. 2011. *Alternative Project Delivery Methods for Water and Wastewater Projects: Do They Save Time and Money?* Leadership and Management in Engineering. 11(3): 231-240. July 2011.
- DCWMAG, 2015. Dominguez Channel Watershed Management Area Group, 2015, *Enhanced Watershed Management Plan for the Dominguez Channel Watershed Management Area Group*, June 2015.
- Discussions with Donald C. Tillman WRP Engineering Staff
- Discussions with Hyperion WRP Engineering Staff
- Discussions with Los Angeles-Glendale WRP Engineering Staff
- Discussions with Terminal Island WRP Engineering Staff
- Dominguez Channel Watershed Management Area Group, 2015, *Enhanced Watershed Management Program for the Dominguez Channel Watershed Management Area Group*, June 2015.
- Edzwalkd, J.K., and J. Haarhoff (2012) *Dissolved Air Flotation for Water Clarification*, McGraw-Hill. New York.
- El Asmar, M., A. Hanna, et al. 2013. Quantifying Performance for the Integrated Project Delivery System as Compared to Established Delivery Systems. *Journal of Construction Engineering and Management*. 139(11). November 2013.
- Enhanced Watershed Management Program for the Ballona Creek Watershed, 2015.
- Enhanced Watershed Management Program for the Dominguez Channel Watershed Management Area Group, 2015.
- EPA, 1999. Preliminary Data Summary of Urban Stormwater Control Measures. EPA-821-R-99-012, Washington, DC.
- ESA PRC, Burbank 2017 Wastewater Change Petition, Initial Study/Negative Declaration, Public Review Draft, April 2017.
- FAO, 1985. Water Quality for Agriculture. 1985.

- FEMA. 2010. *Technical Fact Sheet No. 1.6, Designing for Flood Levels Above the BFE, Home Builder's Guide To Coastal Construction*. December 2010.
- FEMA. 2013a. *Designing for Flood Levels above the BFE after Hurricane Sandy, Hurricane Sandy Recovery Advisory*. FEMA, Federal Insurance and Mitigation Administration, Risk Reduction Division, Building Science Branch. Washington, DC. April.
- FEMA. 2013b. *Flood Insurance Manual*. FEMA, Federal Insurance and Mitigation Administration. Washington, DC. October.
- Fitch, G.J., I. Odeh, et al. 2015. Economic sustainability of DBO water based on wastewater projects in the U.S.: Three case studies. *Journal of Construction Engineering and Management*. 141(5). May 2015.
- Garfin, G., G. Franco, H. Blanco, A. Comrie, P. Gonzalez, T. Piechota, R. Smyth, and R. Waskom, 2014: Ch. 20: Southwest. *Climate Change Impacts in the United States: The Third National Climate Assessment*, J. M. Melillo, Terese (T.C.) Richmond, and G. W. Yohe, Eds., U.S. Global Change Research Program, 462-486. doi:10.7930/J08G8HMN.
- Geosyntec Consultants. 2016. Technical Memorandum, Los Angeles River Low-flow Study. Draft, August 2016.
- Grady, C.P.L., Jr., G.T. Daigger, N.G. Love and C.D.M. Filipe (2011) *Biological Wastewater Treatment*, 3rd Edition, CRC Press, Boca Raton, FL.
- GRASS (Greenways to Rivers Arterial Stormwater System).
- Greeley and Hansen. 1998. *Tres Rios, Arizona Feasibility Study Salt/Gila Groundwater Analysis*. Re-published in Rio Salado Oeste Feasibility Report and adjusted by COE, Mar. 2005.
- Grifman, P. M., J. F. Hart, J. Ladwig, A. G. Newton Mann, M. Schulhof. 2013. Sea Level Rise Vulnerability Study for the City of Los Angeles. USCSG-TR-05-2013.
- Hall, Alex. 2013. Fact Sheet on Climate Change in the Los Angeles Region: Temperature Results. UCLA Dept. of Atmospheric and Oceanic Sciences. December 2013.
- Hammer, M. J., Hammer, M. J., Jr., (2012) *Water and Wastewater Technology*, 7th Edition, Pearson/Prentice-Hall, Upper Saddle River, NJ.
- Intergovernmental Panel on Climate Change (IPCC). 2007. Climate Change 2007: The Physical Science Basis. Contribution of Working Group I to the Fourth Assessment Report of the Intergovernmental Panel on Climate Change. S. Solomon, D. Qin, M. Manning, Z. Chen, M. Marquis, K. B. Averyt, M. Tignor, and H. L. Miller, eds. Cambridge, United Kingdom and New York, New York: Cambridge University Press. p. 996.
- IPCC. 2013: Climate Change 2013: The Physical Science Basis. Contribution of Working Group I to the Fifth Assessment Report of the Intergovernmental Panel on Climate Change. T.F. Stocker, D. Qin, G.-K. Plattner, M. Tignor, S.K. Allen, J. Boschung, A. Nauels, Y. Xia, V. Bex, and P.M. Midgley, eds. Cambridge, United Kingdom and New York, New York: Cambridge University Press. p. 1535.

- Jenkins, S.A. and J. Wasyl, 2005, *Brine Dilution Study for LADWP Desalination Project at Scattergood Generating Station*. February 11, 2005.
- Jin, Y., Goulden, M. L., Faivre, N., Veraverbeke, S., Sun, F., Hall, A., and Randerson, J. T. 2015. Identification of two distinct fire regimes in Southern California: Implications for economic impact and future change. *Environmental Research Letters*, 10(9).
- John C. Crittenden, R. Rhodes Trussell, David W. Hand, Kerry J. Howe, George Tchobanoglous (2012) *Water Treatment: Principles and Design*, 3rd Edition, John Wiley & Sons, Inc., New York.
- Krzeminski, P., J.H. van der Graaf, J. van Lier, Specific Energy Consumption of Membrane Bioreactor for Sewage Treatment, *Water Science Technology*, 2012;65(2): 380-92.
- LA Basin Stormwater Conservation Study
- LA, 2015. City of Los Angeles, Los Angeles County Flood Control District, County of Los Angeles, City of Santa Monica, City of El Segundo, 2015, Santa Monica Bay Jurisdictional Group 2 and 3 *Enhanced Watershed Management Program*, June 2015.
- LABOE, 2016, *Master Schedule Uniform Project Reporting System (UPRS)*, August 2016
- LABOE, *Task Order Solicitation No. 35 Design build documents for the DCT In-Plant Storage Project and development of BOE Design Build Policies and Procedures*, July 2008
- LABOS, Monthly Performance Reports from May 2015 to April 2016.
- LACDPW, 2016, *County of Los Angeles Hydrologic Report, 2014-15*, 2016.
- LACSD/MWD. *Technical Memorandum 3: Groundwater Recharge Requirements*. Prepared by MWH, Trussel Technologies, and Carollo Engineers. 2016
- LADPW County of Los Angeles Department of Public Works Watershed Management Division (2010) Los Angeles County Watershed Model Configuration and Calibration-Part I: Hydrology.
- LADPW, 2015 *Urban Water Management Plan*, April 2015
- LADPW, LABOS, Amended Engineering Report for the Terminal Island Water Reclamation Plant Advanced Water Purification Facility Expansion: Dominguez Gap Barrier Project, January 2015.
- LADPW, LADWP, Terminal Island Water Reclamation Plant Barrier Supplement and Non-Potable Reuse Concepts Report, March 2012.
- LADWP Recycled Water Annual Report, Fiscal Year 2014-2015.
- LADWP, 2002, *Proposed Seawater Desalination Plant Site Selection Fatal Flaw Analysis*, April 12, 2002. Prepared by Psomas.

- LADWP, 2004, *Seawater Desalination Facility Feasibility Study for the Scattergood Generating Station in Playa del Rey*. Prepared by DMJMH+N and Metcalf & Eddy.
- LADWP, 2008, *Scattergood Generation Station Seawater Desalination Pilot Project Preliminary Evaluation Report*, March 10, 2008. Prepared by CDM.
- LADWP, 2010, *Urban Water Management Plan*.
- LADWP, 2011. LADWP, 2010 *Urban Water Management Plan, 2011*.
- LADWP, 2014, *Annual Recycled Water Report, Fiscal Year 2014-15*, August 2015.
- LADWP, 2015 (Prepared by CDM Smith). *Urban Water Management Plan*.
- LADWP, 2015 (Prepared by Geosyntec Consultants). *Stormwater Capture Master Plan*. August.
- LADWP, 2015, *Stormwater Capture Master Plan*, August 2015. Prepared by Geosyntec.
- LADWP, 2015, *Urban Water Management Plan*.
- LADWP, 2015a. LADWP, *Recycled Water Annual Report - Fiscal Year 2014-15*, August 2015.
- LADWP, 2015b. LADWP, *L.A.'s Drinking Water Quality Report - for the period of January 1 through December 31, 2014*. 2015.
- LADWP, 2015c. LADWP, *Stormwater Capture Master Plan*, August 2015.
- LADWP, 2016, *Draft Environmental Impact Report: Los Angeles Groundwater Replenishment Project*, May 2016
- LADWP, 2016, *Recycled Water Annual Report Fiscal Year 2015-16*. August 2016.
- LADWP, 2016. LADWP, 2015 *Urban Water Management Plan, 2015*.
- LADWP, *Urban Water Management Plan*. 2015.
- LADWP. 2016. *Downtown Water Recycling Project Fact Sheet*, Project No. 51066. January 2016.
- LADWP/LASAN, 2006, *City of Los Angeles Integrated Resources Plan*, December 2006.
- LADWP/LASAN, 2012, *Groundwater Replenishment Master Planning Report*, March 2012. Prepared by RMC and CDM.
- LADWP/LASAN, 2012, *Long Term Concepts Report*, March 2012. Prepared by RMC and CDM.
- LADWP/LASAN, 2012, *Non-Potable Reuse Master Planning Report*, March 2012. Prepared by RMC and CDM.
- LADWP/LASAN, 2012, *Recycled Water Master Plan*, October 2012. Prepared by RMC and CDM.

- LADWP/LASAN, 2012, *Recycled Water Master Planning Documents*, October 2012.
- LADWP/LASAN, 2012, *Terminal Island Water Reclamation Plant Barrier Supplement and Non-Potable Reuse Concepts Report*, March 2012. Prepared by RMC and CDM.
- LADWP/LASAN, 2012, *Water IRP 5-Year Review Final Documents*, June 2012.
- LARWQCB, 2014. LA River uses based on the LARWQCB Basin Plan for the Coastal Watersheds of Los Angeles and Ventura Counties, September 11, 2014 (Table 2-1). Beneficial Uses of Inland Surface Waters. Retrieved from LARWQCB: http://www.waterboards.ca.gov/losangeles/water_issues/programs/basin_plan/electronics_documents/BeneficialUseTables.pdf
- Las Virgenes Municipal Water District. 2012. *Recycled Water Seasonal Storage Project Feasibility Study*.
- LASAN (prepared by Arcadis), *East West Valley Interceptor Sewer (EWVIS) Concept Report*, January 2017
- LASAN City of Los Angeles Department of Public Works, Bureau of Sanitation and Department of Water and Power, (2004) *City of Los Angeles Integrated Resources Plan: Facilities Plan. Volume 3: Runoff Management*.
- LASAN projects information website https://www.lacitysan.org/san/faces/home/portal/s-lsh-sp/s-lsh-sp-awpf?_afrc.ctrl-state=h8imyl4k2_53&_afrcLoop=4643485709223648#!
- LASAN, 2014, *Monthly Performance Report*, June 2014.
- LASAN, 2015, *Amended Engineering Report for the Terminal Island Water Reclamation Plant Advanced Water Purification Facility Expansion: Dominguez Gap Barrier Project*, August 2015.
- LASAN, 2015, *Enhanced Watershed Management Programs, Prepared for the Following Watersheds: Ballona Creek, Dominguez Channel, Santa Monica Bay, Upper Los Angeles River, Marine Del Ray*, June 2015.
- LASAN, 2015, *Evaluating Municipal Recycled Water Usage in Concrete Mixes*, September 2015.
- LASAN, 2015, *Upgrades to Pump Plants and Associated Stormwater Treatment Opportunities in the City of Los Angeles Santa Monica Bay Watershed: Implementation Strategy for Pump Plant 647*, June 11, 2015. Prepared by Tetra Tech and Black & Veatch.
- LASAN, 2015, *Wastewater Capital Improvement Program: Fiscal Years 2015/6 – 2024/5*, July 2015.
- LASAN, *Final Environmental Impact Report for Hyperion Treatment Plant Digester Gas Utilization Project: Power and Steam Generation*, August 2013.
- LASAN, *Hyperion Treatment Plant Operation Manual*, March 2011.
- LASAN, *Monthly Performance Reports*, 2013-2015.

- LASAN, *Monthly Performance Reports*, 2014-2015.
- LASAN, OneWater LA – Task 5.
- LASAN, Wastewater Capital Improvement Program Fiscal Years 2015/16 – 2024/25.
- LASAN/LADWP, 2006, *City of Los Angeles Integrated Resources Plan*, December 2006. Prepared by CH:CDM.
- Lee, H.J., H.G. Greene, B.D. Edwards, M.A. Fisher, and W.R. Normark, 2009. Submarine Landslides of the Southern California Borderland. *Geological Society of America Special Papers*, Vol. 454, pp 251-269. 2009.
- Lee, H.J., W.R. Normark, M.A. Fisher, H.G. Greene, B.D. Edwards, J. Locat, 2004. Timing and Extent of Submarine Landslides in Southern California. *Proceedings of the Annual Offshore Technology Conference 3*. January 2004.
- Ligtvoet W et al. 2015. Adaptation to climate change in the Netherlands – Studying related risks and opportunities. The Hague: PBL Netherlands Environmental Assessment Agency.
- Locat, J., H.J. Lee, P. Locat and J. Imran, 2004. Numerical analysis of the mobility of the Palos Verdes debris avalanche, California, and its implication for the generation of tsunamis. *Marine Geology*, Vol. 203, pp 269-280. January 2004.
- Los Angeles Bureau of Engineering (LABOE) 2016 Master Schedule, September 2016.
- Los Angeles Bureau of Engineering (LABOE) 2017 Master Schedule, March 2017.
- Los Angeles Bureau of Engineering (LABOE) Uniform Project Reporting System, <http://eng.lacity.org/iuprs/>, May 6, 2016.
- Los Angeles County Department of Public Works (LACDPH), 2016. Guidelines for Alternative Water Sources Indoor and Outdoor Non-Potable Uses. February 2016.
- Los Angeles Department of Water and Power (LADWP), 2015. Recycled Water Annual Report, Fiscal Year 2014-2015. August 2015.
- Los Angeles Regional Water Quality Control Board (Regional Board), 2012, *Order No. R4-2012-0175 National Pollutant Discharge Elimination System (NPDES) Permit No. CAS004001 Waste Discharge Requirements for Municipal Separate Storm Sewer System (MS4) Discharges within the Coastal Watersheds of Los Angeles County, except those Discharges Originating from the City of Long Beach MS4*, November 8, 2012.
- Los Angeles Regional Water Quality Control Board (Regional Board), 2011, *Order No. R4-2011-0197 NPDES Permit No. CA 0053953*, December 8, 2011.
- Los Angeles Regional Water Quality Control Board (Regional Board), 2012, *Order No. R4-2015-0119 NPDES Permit No. CA 0053856*, June 11, 2015.
- Los Angeles Regional Water Quality Control Board (Regional Board), 2017, *Order No. R4-2017-0063 NPDES Permit No. CA 0053953*.

- Los Angeles Regional Water Quality Control Board Basin Plan, Chapter 3 – Water Quality Objectives. Los Angeles Regional Water Quality Control Board, April 2013.
http://www.waterboards.ca.gov/losangeles/water_issues/programs/basin_plan/basin_plan_documentation.shtml
- Los Angeles River Master Plan prepared in 1996 by LA County Departments of Public Works, Parks and Recreation and Regional Planning, along with the National Park Service's Rivers, Trails, and Conservation Assistance Program
http://ladpw.org/wmd/watershed/la/la_river_plan.cfm
- Los Angeles Sanitation (LASAN)/LADWP, 2006, *City of Los Angeles Integrated Resources Plan*, December 2006.
- Marina del Rey Enhanced Watershed Management Program Agencies, 2015, *Marina del Rey Enhanced Watershed Management Program Plan*, June 25, 2015.
- Maurer, E.P. 2007. Uncertainty in hydrologic impacts of climate change in the Sierra Nevada, California under two emissions scenarios. *Climatic Change*, Vol. 82, No. 3-4, 309-325, DOI: 10.1007/s10584-006-9180-9.
- Mayer, K.E. and W.F. Laudenslayer. 1988. *A Guide to Wildlife Habitats of California*. State of California
- Mayors Executive Directive No. 5, October 2014.
- Meyer, R. 2005. *Atriplex lentiformis*. In: *Fire Effects Information System*, [Online]. U.S. Department of Agriculture, Forest Service, Rocky Mountain Research Station, Fire Sciences Laboratory (Producer). Available:
[http://www.fs.fed.us/database/feis/plants/shrub/atrlen/all.html#BOTANICAL AND ECOLOGICAL CHARACTERISTICS](http://www.fs.fed.us/database/feis/plants/shrub/atrlen/all.html#BOTANICAL_AND_ECOLOGICAL_CHARACTERISTICS).
- Mobility Plan 2035
- Moffatt & Nichol, 2007. *Tsunami Hazard Assessment for the Ports of Long Beach and Los Angeles*, Final Report. April, 2007.
- MWD Water Supply Strategy, 2016.
- MWMPA, 2015. *Marina Del Rey Enhanced Watershed Management Program Agencies, 2015, Marina del Rey Enhanced Watershed Management Program Plan*, June, 2015.
- National Academy of Sciences. 2006. *Surface Temperature Reconstructions for the Last 2,000 Years*. National Academies Press.
- National Oceanic and Atmospheric Administration. 2016. *Sea Level Trends*. Available online at <http://tidesandcurrents.noaa.gov/sltrends/sltrends.shtml>. Accessed April 15, 2016.
- NWRI (2012) *Ultraviolet Disinfection Guidelines for Drinking Water and Water Reuse*, 3rd Edition, Updated Edition, National Water Research Institute, Fountain Valley, CA.

- NYC Department of Environmental Protection (NYCDEP). 2013. NYC Wastewater Resiliency Plan Climate Risk Assessment and Adaptation Study.
- One Water LA – TM NO. 7.1 Hyperion Reclamation Plant Facility Plan Final Draft October 2016.
- One Water LA – TM No. 7.4 Terminal Island Water Reclamation Plant Facility Plan Final Draft October 2016.
- Pace Consulting, 1999. Pointers on Reclaimed Water Contract Negotiations. June 1999.
- PBL. 2013. The Effects of Climate Change in the Netherlands: 2012. PBL Netherlands Environmental Assessment Agency. <http://www.pbl.nl/en/publications/the-effects-of-climate-change-in-the-netherlands-2012/>
- Pierce, David W., Daniel R. Cayan, and Bridget L. Thrasher. 2014. "Statistical Downscaling Using Localized Constructed Analogs (LOCA)." *J. Hydrometeor.* 15, 2558–2585.
- Qasim, S. (1999) *Wastewater Treatment Plants, Planning, Design and Operations*, 2nd Edition, Technomic Publishing Co., Lancaster, PA.
- Raff, D. A., T. Pruitt, and L.D. Brekke. 2009. "A framework for assessing flood frequency based on climate projection information, Hydrol." *Earth Syst. Sci.* 13, 2119-2136.
- Regional Water Quality Control Board Workshop, November 15, 2012. "Progress on Salt and Nutrient Management Plans." [PowerPoint slides]. Retrieved from: http://www.swrcb.ca.gov/losangeles/water_issues/programs/salt_and_nutrient_management/StakeHolderWorkshop/2_Raymond%20and%20San%20Gabriel%20Basins_Kevin%20Smead.pdf
- RMC/CDM Smith. 2012. *Recycled Water Master Plan, Non-Potable Reuse Master Planning Report*. March 2012.
- Rupp DE, JT Abatzoglou, KC Hegewisch, and PW Mote. 2013. "Evaluation of CMIP5 20th century climate simulations for the Pacific Northwest USA." *Journal of Geophysical Research: Atmospheres*. 118(19):10,884-10,906.
- Salt and Nutrient Management Plan, 2015. Central Basin and West Coast Basin, Southern Los Angeles County, California.
- Santa Monica Bay Jurisdictional Group 2 and 3, 2015, *Santa Monica Bay Jurisdictional Group 2 and 3 Enhanced Watershed Management Program*, June 29, 2015. Prepared by MWH.
- Shrestha, P., R. Maharajan, et al. 2016. *Comparison of Utility Managers' and Project Managers' Satisfaction Rating of Alternative Project Delivery Methods Used in Water and Wastewater Infrastructures*. Public Works Management & Policy. January 2016.
- Shrestha, P., R. Maharjan, et al. 2014. *Alternative Project Delivery Methods for Water and Wastewater Projects: The Satisfaction Level of Owners*. Construction Research Congress, American Society of Civil Engineers: 1733-1742. May 2014.

- State of California Natural Resources Agency, Department of Water Resources Southern Region Office. *Watermaster Service in the West Coast Basin Los Angeles County - July 1, 2013 - June 30, 2014*. September 2014
- State Water Resources Control Board. 1968. "California Antidegradation Policy." Resolution No. 68-16.
- State Water Resources Control Board. 2013. "Recycled Water Policy".
- State Water Resources Control Board. 2014. "Regulations Related to Recycled Water." Includes Title 22 Code of Regulations.
- State Water Resources Control Board. 2015. "Safe Drinking Water Plan for California: Report to the Legislature."
- Sun, F., Hall, A., Schwartz, M., Walton, D., and Berg, N. 2016. Twenty-First-Century Snowfall and Snowpack Changes over the Southern California Mountains. *Journal of Climate*, 29.
- Sun, F., Walton, D. B., and Hall, A. 2015. A Hybrid Dynamical–Statistical Downscaling Technique. Part II: End-of-Century Warming Projections Predict a New Climate State in the Los Angeles Region. *Journal of Climate*, 28(12).
- SWRCB, 2016 State Water Resources Control Board and California Environmental Protection Agency, *Investigation on the Feasibility of Developing Uniform Water Recycling Criteria for Direct Potable Reuse*, December 2016.
- Taghvaeian S. and A. Sutherland (2015) Evaporation Losses from Shallow Water Bodies in Oklahoma. Oklahoma Cooperative Extension Service of Oklahoma State University. BAE-1529.
- Taylor, Karl E., Ronald J. Stouffer, and Gerald A. Meehl. 2012. An Overview of CMIP5 and the Experiment Design. *Bull. Amer. Meteor. Soc.* 93, 485–498.
- Tchobanoglous, G., F.L. Burton, and H.D. Stensel (2013) *Wastewater Engineering: Treatment and Reuse*, 5th Edition, McGraw-Hill, New York.
- Tchobanoglous, G., F.L. Burton, and H.D. Stensel, & Metcalf and Eddy (2014) *Wastewater Engineering Treatment and Resource Recovery*, 5th Edition, McGraw-Hill, New York.
- Terminal Island Water Reclamation Plant Advanced Water Purification Facility Operation Optimization Plan Draft October 2016.
- U.S. Bureau of Reclamation (2004). Los Angeles River Physical and Biological Habitat Assessment. Report of 2003 Field Activities. April 2004.
- U.S. Geological Survey (USGS), 2015. Climate Change impacts to the Southern California Coast. Presented at AdaptLA climate change workshop in Los Angeles, CA, October 2, 2015. Available at: http://walrus.wr.usgs.gov/coastal_processes/cosmos/Barnard_CoSMoSOOverview_AdaptLA_Oct2015.pdf

- ULAR WMG Upper Los Angeles River Watershed Management Group (2015) Enhanced Watershed Management Program (EWMP), January 2016
- ULARA Watermaster (2014) Annual Report Upper Los Angeles River Area Watermaster 2012-2013 Water Year. December, 2014
- ULARG, 2015. Upper Los Angeles River EWMP Group, 2015, *Enhanced Watershed Management Program (EWMP) for the Upper Los Angeles River EWMP Group*, June, 2015.
- University of California, Division of Agriculture and Natural Resources; Center for Landscape & Urban Horticulture. 2016. *Landscape Water Requirement Calculators*. Available: http://ucanr.edu/sites/urbanhort/water_use_of_turfgrass_and_landscape_plant_materials/water_demand_calculators/water_demand_calculators/index.cfm.
- Upper Los Angeles River Watershed Management Group, 2015, *Enhanced Watershed Management Program for the Upper Los Angeles River Watershed*, May 2015. Prepared by Black & Veatch.
- US Bureau of Reclamation, Los Angeles River Physical and Biological Habitat Assessment Report of 2003 Field Activities, April 2004
- USACE U.S. Army Corps of Engineers (2010a) HEC-RAS River Analysis System User's Manual Version 4.1, January 2010.
- USACE U.S. Army Corps of Engineers (2010b) HEC-RAS River Analysis System Hydraulic Reference Manual Version 4.1, January 2010.
- USACE U.S. Army Corps of Engineers (2015) Los Angeles River Ecosystem Restoration Feasibility Study Draft-Appendix E
- USACE, 2015, *Los Angeles River Ecosystem Restoration Integrated Feasibility Report (aka, ARBOR Study – Alternative with Restoration Benefits and Opportunities for Revitalization)*, September 2015.
- USACE, 2015. *Los Angeles River Ecosystem Restoration Integrated Feasibility Report Volume 1: Integrated Feasibility Report*
- USACE, 2016. *Floodplain Analysis, Los Angeles River: Barham Boulevard to First Street, Flood Plain Management Services Special Study, Los Angeles, California*. U.S. Army Corps of Engineers, Los Angeles District, Engineering Division, Hydrology and Hydraulics Branch, Los Angeles, CA. October 2016.
- USACE, Los Angeles River Ecosystem Restoration Integrated Feasibility Report Volume 1: Integrated Feasibility Report, September 2015
- USBR, 2004. Los Angeles River Recycled Water Optimization Study. Physical and Biological Habitat Assessment.
- USEPA, 2004. Guidelines for Water Reuse. September 2004.
- USEPA, Energy Star Portfolio Manager: Energy Use in Wastewater Treatment Plants, January 2015.

- Villaraigosa, A. R. 2008. Securing L.A.'s water supply. City of Los Angeles Department of Water and Power Rep., 32 pp. [Available online at http://www.greencitiescalifornia.org/assets/water/LA_Emergency-Water-Conservation-Plan_Water-Supply-Report-2008.pdf.]
- Walsh, J., D. Wuebbles, K. Hayhoe, J. Kossin, K. Kunkel, G. Stephens, P. Thorne, R. Vose, M. Wehner, J. Willis, D. Anderson, S. Doney, R. Feely, P. Hennon, V. Kharin, T. Knutson, F. Landerer, T. Lenton, J. Kennedy, and R. Somerville, 2014: Ch. 2: *Our Changing Climate. Climate Change Impacts in the United States: The Third National Climate Assessment*, J. M. Melillo, Terese (T.C.) Richmond, and G. W. Yohe, Eds., U.S. Global Change Research Program, 19-67. doi:10.7930/J0KW5CXT.
- Wang, Z., D. Wang, et al. 2013. Selection of construction project delivery method based on value-added analysis: A theoretical framework. International Conference on Construction and Real Estate Management: Construction and Operation in the Context of Sustainability, ICCREM 2013, Karlsruhe, Germany, American Society of Civil Engineers (ASCE). October 2013.
- Water Replenishment District of Southern California Central Basin Watermaster Administrative Body. *Watermaster Service in the West Coast Basin - Los Angeles County - July 1, 2014 - June 30, 2015*. October 2016
- Water Replenishment District of Southern California Central Basin Watermaster Administrative Body. *Watermaster Service in the Central Basin - Los Angeles County - July 1, 2014 - June 30, 2015*. July 2016
- Water Replenishment District of Southern California Central Basin Watermaster Administrative Body. *Watermaster Service in the Central Basin - Los Angeles County - July 1, 2013 - June 30, 2014*. November 2014
- Water Replenishment District of Southern California, 2016, *Groundwater Basins Master Plan*, September 2016. Prepared by CH2M and RMC.
- Water Replenishment District of Southern California. *Groundwater Basins Master Plan*. CH2M Hill, RMC. September 2012
- Water Replenishment District of Southern California. *Regional Groundwater Monitoring Report Central And West Coast Basin Los Angeles County, California, Water Year 2008-2009*. February 2010.
- Water Replenishment District of Southern. *California Regional Groundwater Monitoring Report Water Year 2014-2015: Central and West Coast Basins Los Angeles County, California*. February 2016.
- WEF (2012) *Solids Process Design and Management*, Water Environment Federation, Alexandria, VA.
- Weiss, P.T., J.S. Gulliver, and A.J. Erickson, 2005. The Cost and Effectiveness of Stormwater Management Practices. MN/ RC-2005-23, Minnesota Dept. of Transportation, St. Paul, MN.
- WESD, 2015. Wastewater Engineering Services Division, Bureau of Sanitation, City of Los Angeles, *Fiscal year 2014/15 Contract Agencies Flows*. 2015.

WESD, 2015. Wastewater Engineering Services Division, Bureau of Sanitation, City of Los Angeles, *Watershed tributary areas GIS Data*. 2015.

WESD, 2015. Wastewater Engineering Services Division, Bureau of Sanitation, City of Los Angeles, *Fiscal year 2014/15 recycled water flows*. 2015.

WESD, 2015. Wastewater Engineering Services Division, Bureau of Sanitation, City of Los Angeles, *Fiscal year 2014/15 Industrial Wastewater Flows*. 2015.

West Basin Municipal Water District, *Desalination Demonstration Facility Intake Effects Assessment Report*, August 13, 2014. Prepared by Tenera Environmental.

White Paper - Use of Financial Incentives for Stormwater Fees in Los Angeles County (Coalition of our Water Future).

WPD, 2015. Watershed Protection Division, City of Los Angeles, *Low flow Diversion GIS Data*. 2015.

WRCCC, 2015. Western Regional Climate Control Center, Reno Nevada, *Los Angeles DWTN USC Campus, California (045115)*. 2015.

Others documents and sources utilized include:

- August 2016 Wastewater Treatment Plant Program Master Schedule, Los Angeles Bureau of Engineering (LABOE).
- California Friendly Garden information - <http://www.bewaterwise.com/Gardensoft/index.aspx>
- Caltrans, 2013. Main Street California is an informational guide published in 2013 – Caltrans
- Complete Streets Design Guide
- Conversations with LAGWRP Staff
- Draft Green Alleys Master Plan
- GRASS Summary Report - 2013
- Greenways to Rivers Arterial Stormwater System (GRASS) Summary Report - 2013
- <http://bondaccountability.resources.ca.gov/p1.aspx>
- <http://rposd.lacounty.gov/2016-ballot-measure/>
- <http://www.lastormwater.org/about-us/funding/>
- <http://www.lastormwater.org/blog/category/prop-o-projects/>
- <http://www.lastormwater.org/green-la/low-impact-development/faqs/what-is-the-plan-approval-process/>
- <https://watereuse.org/water-reuse-101/glossary/>

- <https://www.congress.gov/bill/114th-congress/senate-bill/612/text>
- <https://www.lacitysan.org>
- LA County Model Design Manual for Living Streets
- LA Green Building Code - <http://ladbs.org/LADBSWeb/green-bldg.jsf>
- LA Greenway 2020 information can be found at <http://www.larivercorp.com/greenway2020>
- LA River Revitalization information can be found at <http://www.lariver.org/index.htm>
- LABOE 2016 Master Schedule, August 2016
- LABOE Engineering projects information website, <http://eng.lacity.org/iuprs/>
- LA's Transportation Element as Mobility Plan 2035
- Lastormwater.org
- Los Angeles Bureau of Engineering (LABOE) 2016 Master Schedule, March 2016
- Metro, Union Station Master Plan - <https://www.metro.net/projects/la-union-station/>
- TIWRP Engineering Staff
- Transforming Alleys into Green Infrastructure - USC 2008
- www.livingstreetsla.org

APPENDIX B – FUTURE INTEGRATION OPPORTUNITIES

This Appendix includes brief descriptions of the 27 concept options listed in Table B.1. Full descriptions, including key assumptions, project component sizing, cost estimates, project partners, maps, implementation challenges, and considerations are included in Appendix C of TM 5.2 (see Volume 5).

Table B.1 List of Concept Options			
Future Integration Strategy	Concept ID#	Concept Name	Estimated Yield (AFY)
Distributed Stormwater BMPs	1	Green Streets – Upper Los Angeles River Watershed	11,900 ⁽¹⁾
	2	Green Streets – Ballona Creek Watershed	2,300 ⁽¹⁾
	3	Green Streets – Dominguez Channel Watershed	2,600 ⁽¹⁾
	4	Green Streets – Santa Monica Bay/Marina del Rey Watersheds	580 ⁽¹⁾
LA River Storage and Use	7	Upper Los Angeles River to Tillman WRP	5,600
	8A	LA River Recharge into LA Forebay using Injection Wells	25,000
	8B	LA River Recharge into LA Forebay using Dry Wells	25,000
Potable Reuse with Groundwater Augmentation	9	Tillman WRP to San Fernando Basin Injection Wells	15,000
	10	Hyperion WRP to West Coast Basin Injection Wells	20,000
	11	Hyperion WRP to Central Basin Injection Wells	75,000
	12	Hyperion WRP to Central Basin with Spreading Basins	95,000
	13	MBR at Hyperion WRP to Regional System	95,000
Potable Reuse with Raw Water Augmentation	14	Hyperion WRP to San Fernando Basin Injection Wells	20,000
	15	Tillman WRP to Los Angeles Aqueduct Filtration Plant	15,000
	20	Hyperion WRP to Los Angeles Aqueduct Filtration Plant	95,000
Potable Reuse with Treated Water Augmentation	21	Central LA Satellite WRP to Los Angeles Aqueduct Filtration Plant	95,000
	16	Tillman WRP to LADWP Distribution System	15,000
	17	LA/Glendale (LAG) WRP to Headworks Reservoir	6,000
	18	Hyperion WRP to LADWP Distribution System	95,000
Non-Potable Reuse	19	Hyperion WRP to Headworks Reservoir	95,000
	23	Increase Recycled Water Demand beyond 2015 UWMP	16,700
Ocean Desal	24	Rancho Park Water Reclamation Facility	3,600
	25	Ocean Desalination	28,000
Flow Management ⁽²⁾	5	Dry Weather Low Flow Diversions	6,200
	6	Wet Weather Flow Diversions	1,000
	22	East-West Valley Interceptor Sewer	n/a ⁽³⁾
	26	Japanese Garden & Sepulveda Basin Lakes Recirculation	20,000

Notes:

(1) It is estimated that the total citywide water supply benefit of the stormwater program (including Green Streets) is approximately 110,000 AFY under normal-year conditions. These numbers will vary greatly depending on hydrologic conditions and sequencing of storm events.

(2) Flow management concepts are not a strategy, but rather prerequisite concepts for other potable reuse concepts. Concept Options #5 and #6 also provide stormwater quality benefits.

(3) The EWWIS does not provide new supply yield. EWWIS has an estimated conveyance capacity of 11.4 mgd to reroute and increase flows to Donald C. Tillman WRP to maximize reuse opportunities from this facility.

Concept Option 1, Green Streets – Upper Los Angeles River Watershed

Develop green streets projects as identified in the Enhanced Watershed Management Plan for the Los Angeles River Watershed (Los Angeles River Watershed EWMP). The estimated yield is 11,900 AFY under normal year conditions, while the unit cost is estimated to be roughly \$7,500 per AF. The concept flow schematic is shown on Figure B.1 - B.4, while more detailed information can be found in Appendix C of TM 5.2 (see Volume 5).

Concept Option 2, Green Streets – Ballona Creek Watershed

Develop distributed projects (green streets) as identified in the Enhanced Watershed Management Plan for the Ballona Creek Watershed (Ballona Creek watershed EWMP). The estimated yield is 2,300 AFY under normal year conditions, while the unit cost is estimated to be roughly \$17,600 per AF. The concept flow schematic is shown on Figure B.1 - B.4, while more detailed information can be found in Appendix C of TM 5.2.

Concept Option 3, Green Streets – Dominguez Channel Watershed

Develop the green streets projects as identified in the Enhanced Watershed Management Plan for the Dominguez Channel Watershed (Dominguez Channel Watershed EWMP). The estimated yield is 2,600 AFY under normal year conditions, while the unit cost is estimated to be roughly \$5,400 per AF. The concept flow schematic is shown on Figure B.1 - B.4, while more detailed information can be found in Appendix C of TM 5.2 (see Volume 5).

Concept Option 4, Green Streets – Santa Monica Bay/Marina del Rey Watersheds

Develop the green streets projects as identified in the Enhanced Watershed Management Plan for the Santa Monica Bay Watershed (SMB J2 & J3 EWMP and SMB J7 WMP) and in the Enhanced Watershed Management Plan for the Marina del Rey Watershed (MDR Watershed EWMP). The estimated yield is 580 AFY under normal year conditions, while the unit cost is estimated to be roughly \$27,100 per AF. The concept flow schematic is shown on Figure B.1 - B.4, while more detailed information can be found in Appendix C of TM 5.2 (see Volume 5).

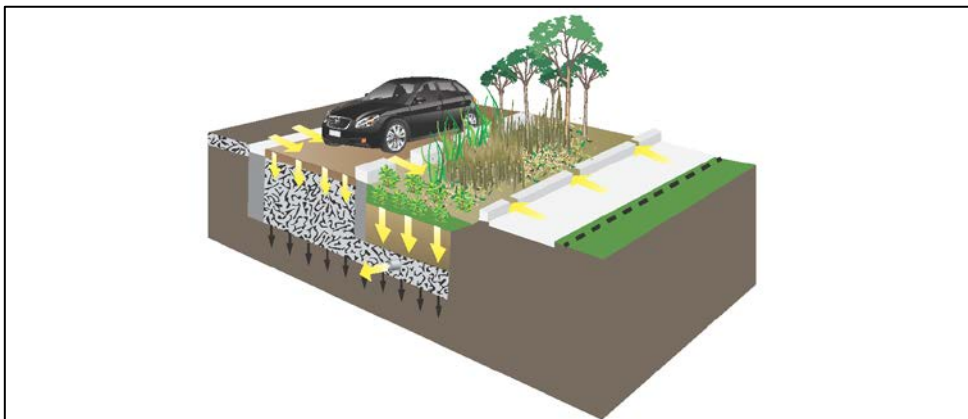

Figure B.1 - B.4 - Green Streets

Concept Option 5, Dry Weather Low Flow Diversions

Collect low flows from the stormwater system and transfer the collected flows to the sewer system for treatment. The estimated yield is 6,200 AFY under normal year conditions, while the unit cost is estimated to be roughly \$1,000 per AF. The concept flow schematic is shown on Figure B.5, while more detailed information can be found in Appendix C of TM 5.2 (see Volume 5).

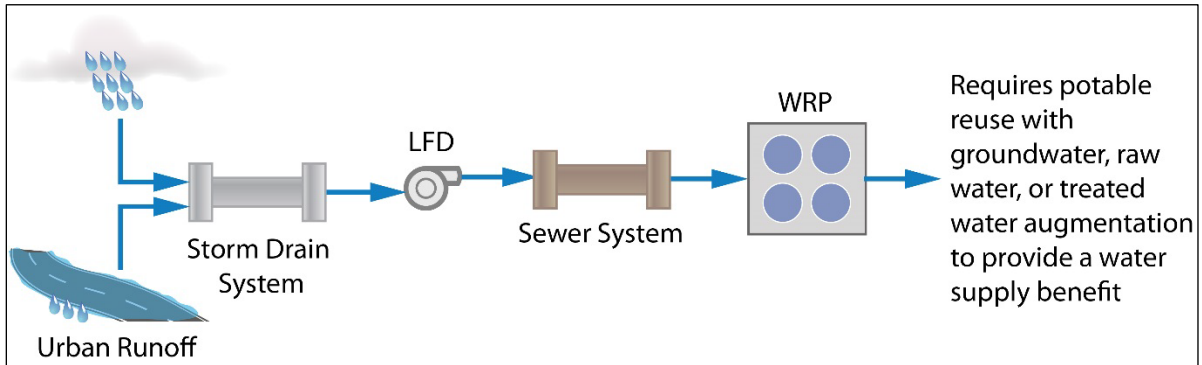

Figure B.5 - Dry Weather Low Flow Diversions

Concept Option 6, Wet Weather High Flow Diversions

Store a portion of wet weather flows from the stormwater system, after the rain event transfer the collected flows to the sewer system for treatment. The estimated yield is 1,000 AFY under normal year conditions, while the unit cost is estimated to be roughly \$10,300 per AF. The concept flow schematic is shown on Figure B.6, while more detailed information can be found in Appendix C of TM 5.2 (see Volume 5).

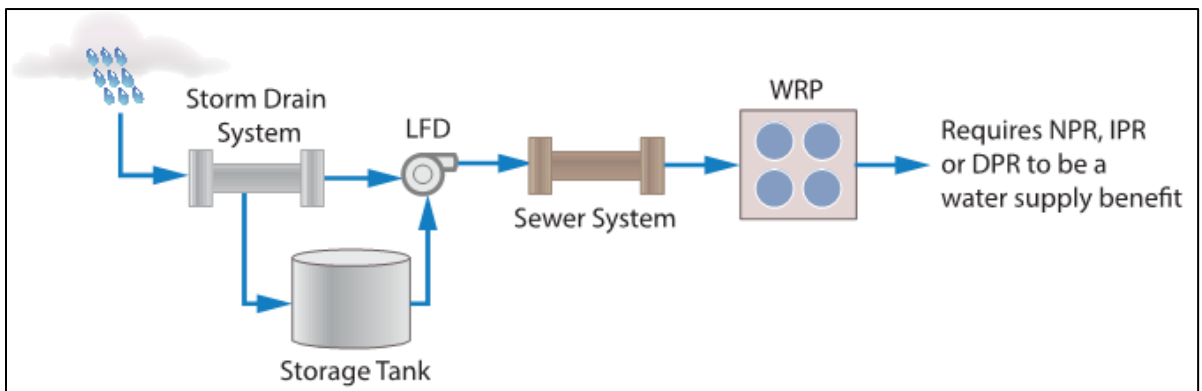

Figure B.6 - Wet Weather High Flow Diversions

Concept Option 7, Upper Los Angeles River to Tillman WRP

Divert flows from the Upper LA River to Tillman WRP for reuse. The estimated yield is 5,600 AFY under normal year conditions, while the unit cost is estimated to be roughly \$160 per AF. The concept flow schematic is shown on Figure B.7, while more detailed information can be found in Appendix C of TM 5.2 (see Volume 5).

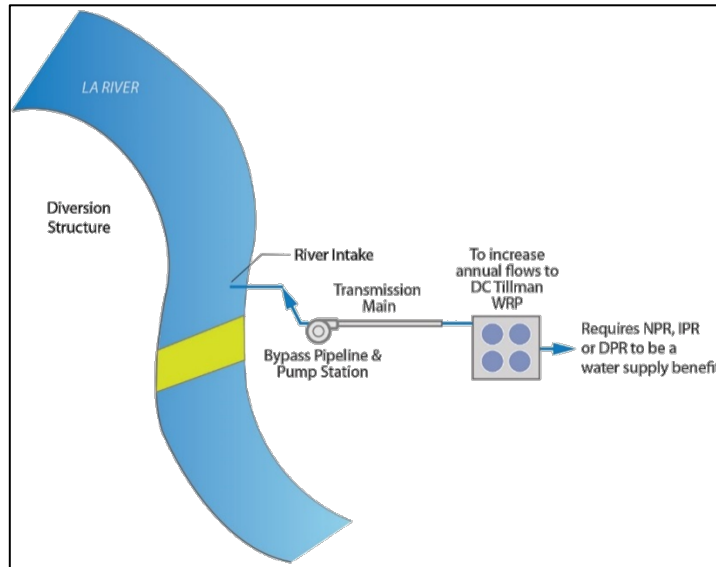

Figure B.7 - Upper Los Angeles River to Tillman WRP

Concept Option 8A, LA River Recharge into LA Forebay using Injection Wells

Divert flows from the LA River to the LA Forebay to recharge Central Basin. The estimated yield is 25,000 AFY under normal year conditions, while the unit cost is estimated to be roughly \$2,100 per AF. The concept flow schematic is shown on Figure B.8A, while more detailed information can be found in Appendix C of TM 5.2 (see Volume 5).

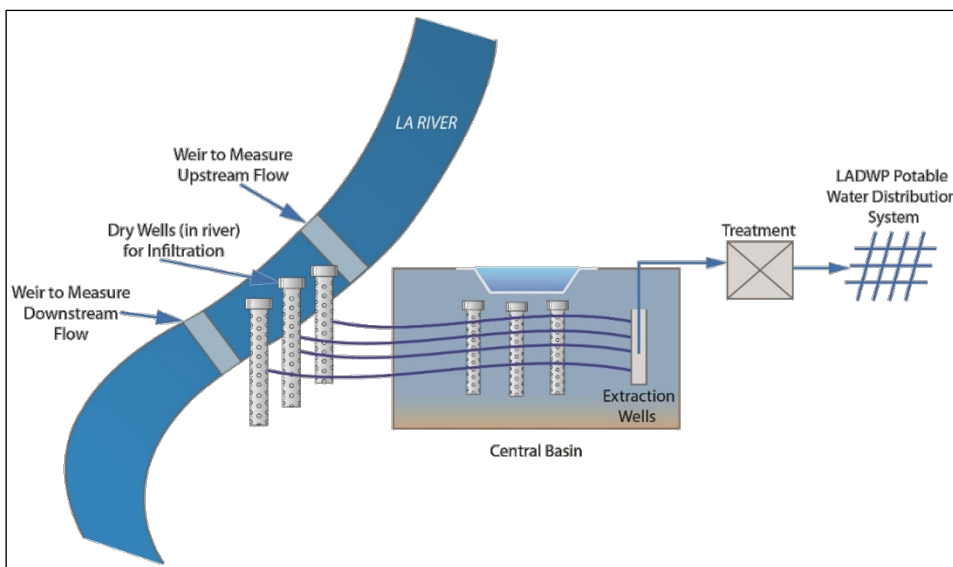

Figure B.8A - LA River Recharge into LA Forebay using Injection Wells

Concept Option 8B, LA River Recharge into LA Forebay using Dry Wells

Divert flows from the LA River to the LA Forebay to recharge Central Basin. The estimated yield is 25,000 AFY under normal year conditions, while the unit cost is estimated to be roughly \$1,000 per AF. The concept flow schematic is shown on Figure B.8B, while more detailed information can be found in Appendix C of TM 5.2 (see Volume 5).

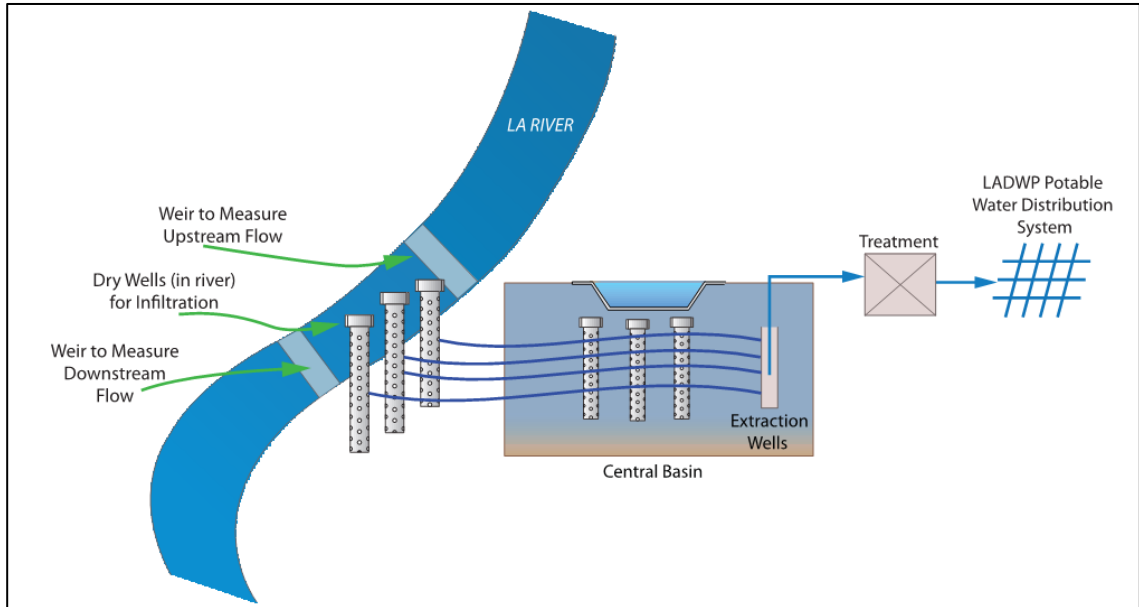

Figure B.8B - LA River Recharge into LA Forebay using Dry Wells

Concept Option 9, Tillman WRP to San Fernando Basin Injection Wells

Treat Donald C. Tillman Water Reclamation Plant (DCTWRP) effluent with Advanced Water Purification Facility (AWPF); recharge into San Fernando Basin (SFB) by injection wells; extract water for potable use. The estimated yield is 15,000 AFY under normal year conditions, while the unit cost is estimated to be roughly \$1,600 per AF. The concept flow schematic is shown on Figure B.9, while more detailed information can be found in Appendix C of TM 5.2 (see Volume 5).

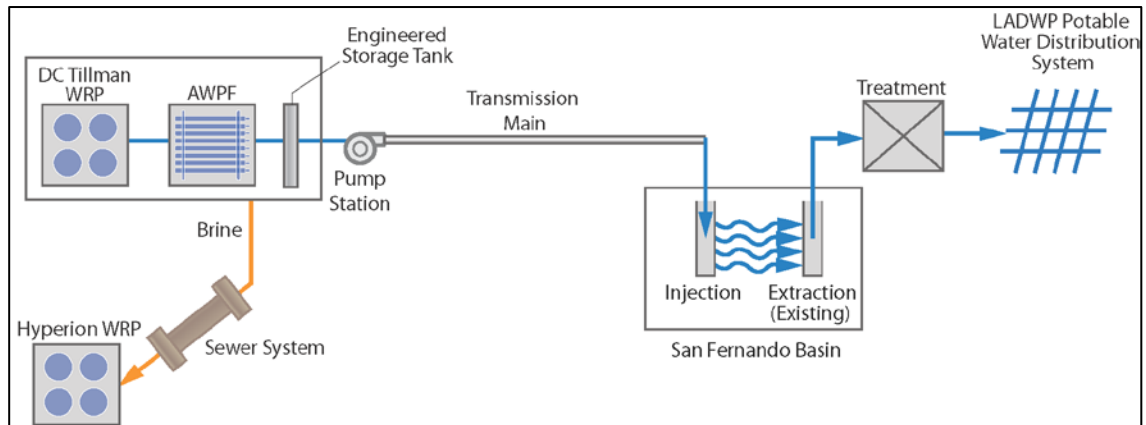

Figure B.9 - Tillman WRP to San Fernando Basin Injection Wells

Concept Option 10, Hyperion WRP to West Coast Basin Injection Wells

Treat HWRP effluent with AWPf; recharge into West Coast Basin by injection wells; extract water for potable use. The estimated yield is 20,000 AFY under normal year conditions, while the unit cost is estimated to be roughly \$3,200 per AF. The concept flow schematic is shown on Figure B.10, while more detailed information can be found in Appendix C of TM 5.2 (see Volume 5).

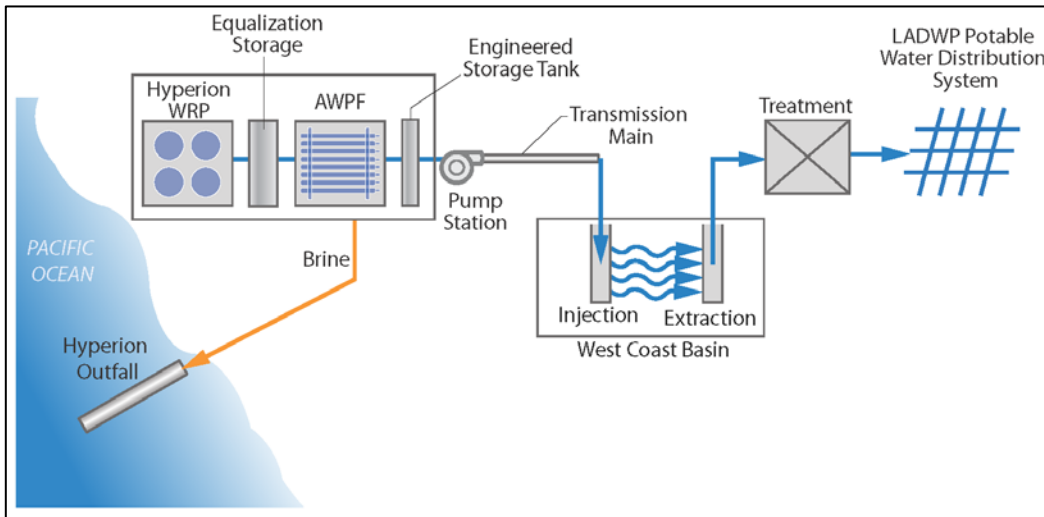

Figure B.10 - Hyperion WRP to West Coast Basin Injection Wells

Concept Option 11, Hyperion WRP to Central Basin Injection Wells

Treat HWRP effluent with AWPf; recharge into Central Basin by injection wells; extract water for potable use. The estimated yield is 75,000 AFY under normal year conditions, while the unit cost is estimated to be roughly \$2,700 per AF. The concept flow schematic is shown on Figure B.11, while more detailed information can be found in Appendix C of TM 5.2 (see Volume 5).

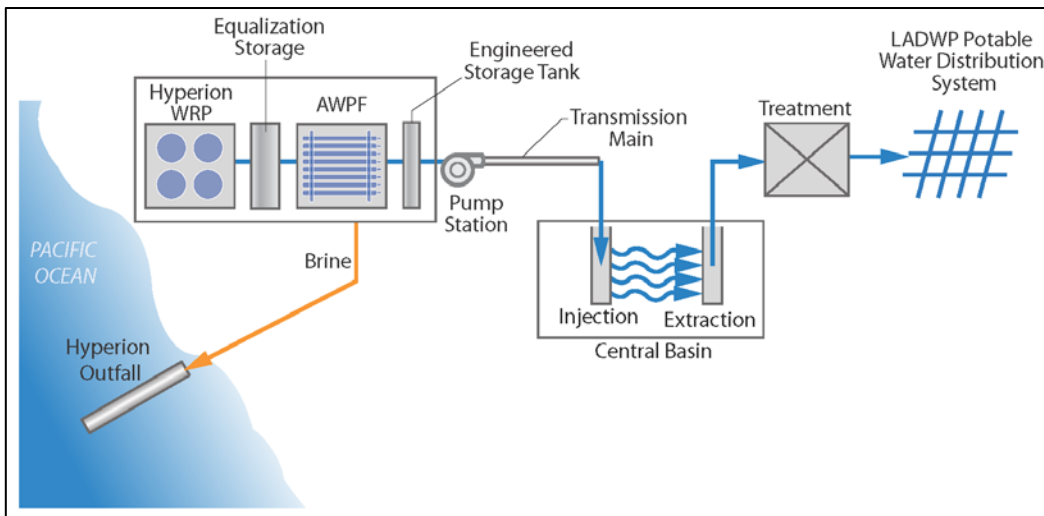

Figure B.11 - Hyperion WRP to Central Basin Injection Wells

Concept Option 12, Hyperion WRP to Central Basin with Spreading Basins

Treat Hyperion Water Reclamation Plant (HWRP) effluent with Advanced Water Purification Facility (AWPF) and convey water to the existing Rio Hondo Spreading Basins at Montebello Forebay; recharge by surface spreading; extract, treat and pump potable water into LADWP distribution system. The estimated yield is 95,000 AFY under normal year conditions, while the unit cost is estimated to be roughly \$2,600 per AF. The concept flow schematic is shown on Figure B.12, while more detailed information can be found in Appendix C of TM 5.2 (see Volume 5).

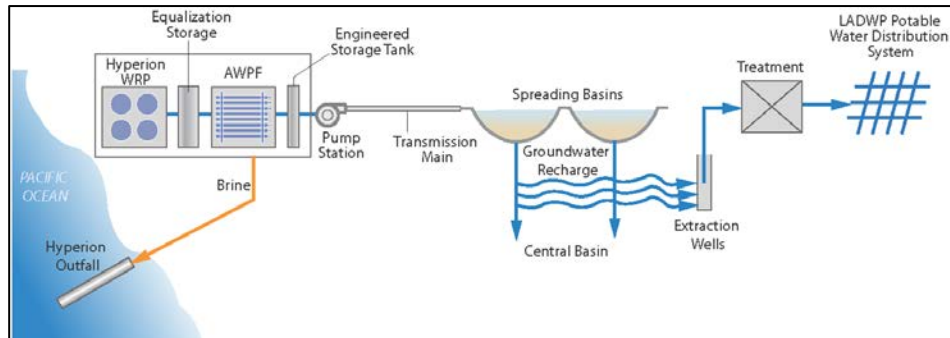

Figure B.12 - Hyperion WRP to Central Basin with Spreading Basins

This concept has a fatal flaw in that spreading capacity at Montebello Forebay spreading grounds capacity is accounted for by the Water Replenishment Groundwater Reliability Improvement Project.

Concept Option 13, MBR at Hyperion WRP to Regional System

Treat HWRP effluent with a membrane bioreactor (MBR). Deliver water to a regional system for recharge into a groundwater basin to be extracted for potable use by other regional systems. This project also may be used for direct potable reuse in the future. Other treatment by the regional system will be required. LADWP could purchase this water from a regional system for potable use. The estimated yield is 95,000 AFY under normal year conditions, while the unit cost is estimated to be roughly \$1,500 per AF. The concept flow schematic is shown on Figure B.13, while more detailed information can be found in Appendix C of TM 5.2 (see Volume 5).

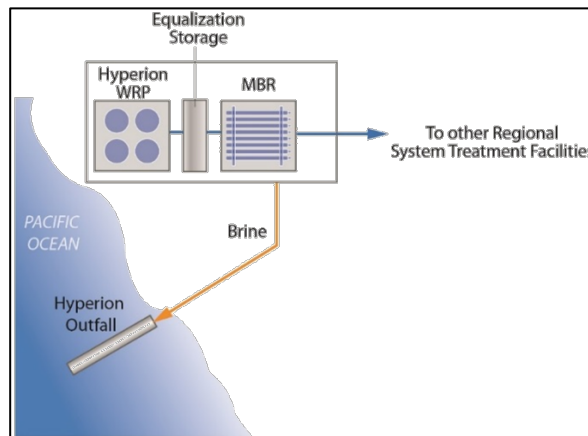

Figure B.13 - MBR at Hyperion WRP to Regional System

Concept Option 14, Hyperion WRP to San Fernando Basin Injection Wells

Treat Hyperion Water Reclamation Plant (HWRP) effluent with Advanced Water Purification Facility (AWPF) and pump water over the Santa Monica Mountains to recharge into SFB by injection wells; extract water for potable use. The estimated yield is 20,000 AFY under normal year conditions, while the unit cost is estimated to be roughly \$2,400 per AF. The concept flow schematic is shown on Figure B.14, while more detailed information can be found in Appendix C of TM 5.2 (see Volume 5).

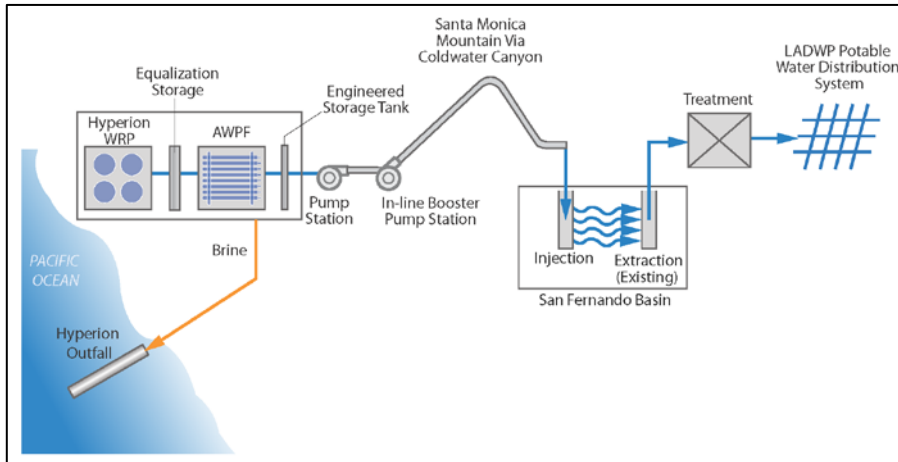

Figure B.14 - Hyperion WRP to San Fernando Basin Injection Wells

Concept Option 15, Tillman WRP to Los Angeles Aqueduct Filtration Plant

Expand Donald C. Tillman Water Reclamation Plant (DCTWRP) Advanced Water Purification Facility (AWPF) and convey direct potable reuse flows to the Los Angeles Aqueduct Filtration Plant (LAAFP) and then to LADWP distribution. The estimated yield is 15,000 AFY under normal year conditions, while the unit cost is estimated to be roughly \$1,500 per AF. The concept flow schematic is shown on Figure B.15, while more detailed information can be found in Appendix C of TM 5.2 (see Volume 5).

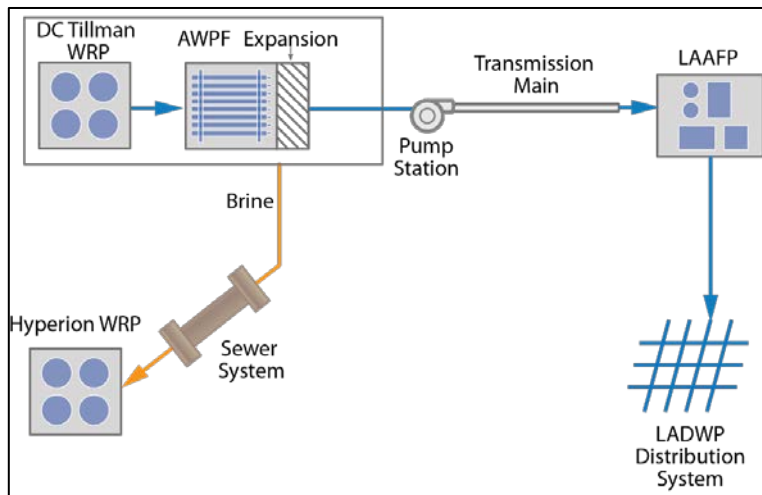

Figure B.15 - Tillman WRP to Los Angeles Aqueduct Filtration Plant

Concept Option 16, Tillman WRP to LADWP Distribution System

Treat Donald C. Tillman (DCT) effluent at the Advanced Water Purification Facility (AWPF) and pump water directly into the LADWP distribution system. The estimated yield is 15,000 AFY under normal year conditions, while the unit cost is estimated to be roughly \$1,300 per AF. The concept flow schematic is shown on Figure B.16, while more detailed information can be found in Appendix C of TM 5.2 (see Volume 5).

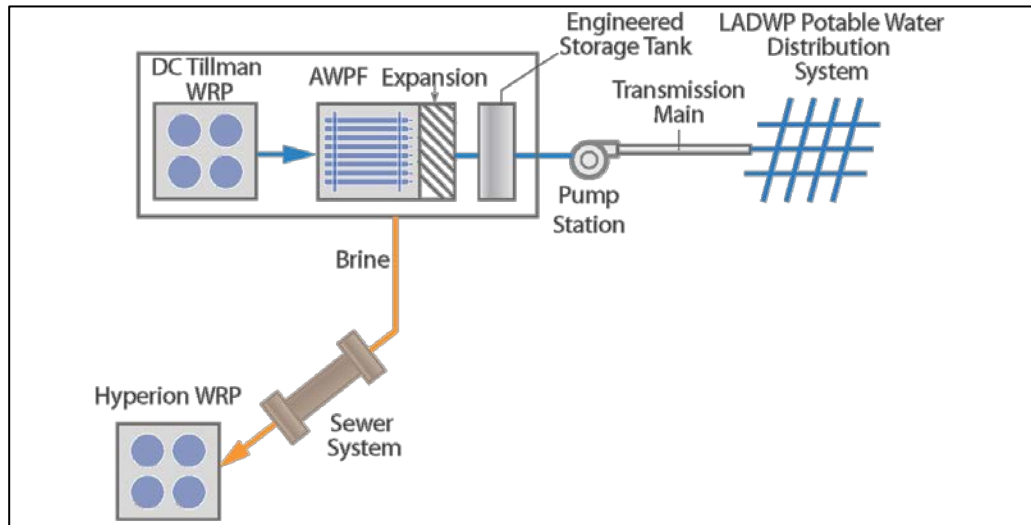

Figure B.16 - Tillman WRP to LADWP Distribution System

Concept Option 17, LA/Glendale (LAG) WRP to Headworks Reservoir

Treat LA-Glendale WRP effluent at an Advanced Water Purification Facility (AWPF) and pump water directly into the LADWP distribution system at Headworks Reservoir. The estimated yield is 6,000 AFY under normal year conditions, while the unit cost is estimated to be roughly \$1,500 per AF. The concept flow schematic is shown on Figure B.17, while more detailed information can be found in Appendix C of TM 5.2 (see Volume 5).

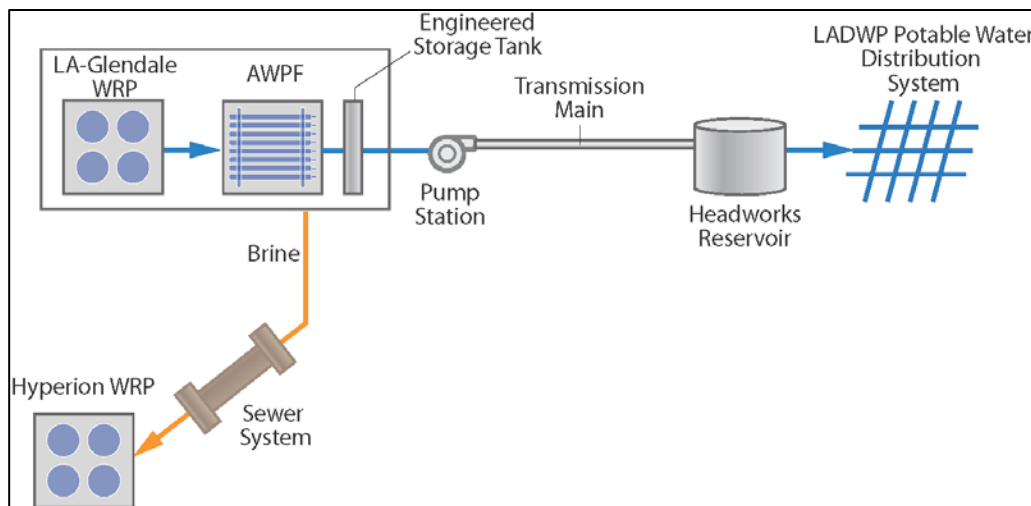

Figure B.17 - LA/Glendale (LAG) WRP to Headworks Reservoir

Concept Option 18, Hyperion WRP to LADWP Distribution System

Treat Hyperion Water Reclamation Plant (HWRP) effluent at a Advanced Water Purification Facility (AWPF) and pump water directly into the LADWP distribution system. The estimated yield is 95,000 AFY under normal year conditions, while the unit cost is estimated to be roughly \$2,000 per AF. The concept flow schematic is shown on Figure B.18, while more detailed information can be found in Appendix C of TM 5.2 (see Volume 5).

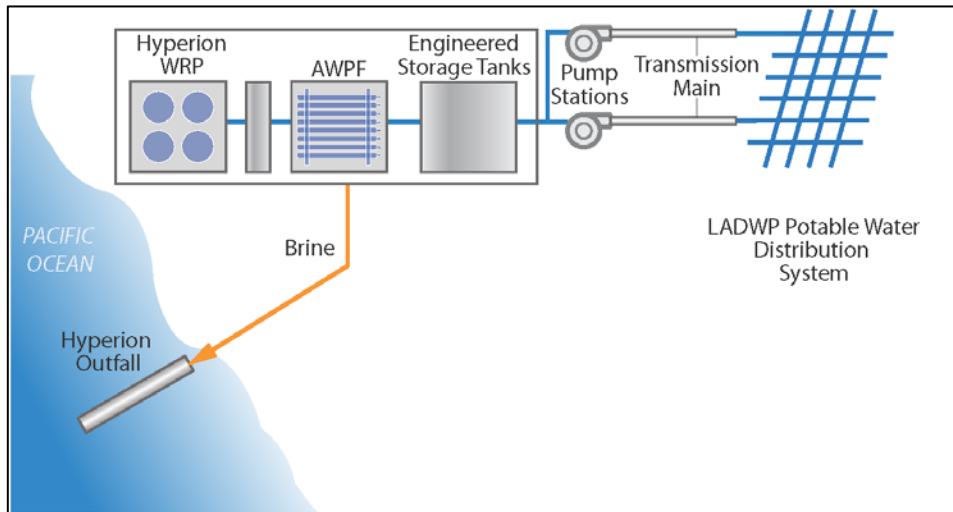

Figure B.18 - Hyperion WRP to LADWP Distribution System

Concept Option 19, Hyperion WRP to Headworks Reservoir

Treat Hyperion Water Reclamation Plant (HWRP) effluent at a Advanced Water Purification Facility (AWPF) and pump water directly to the Headworks Reservoir. The estimated yield is 95,000 AFY under normal year conditions, while the unit cost is estimated to be roughly \$2,400 per AF. The concept flow schematic is shown on Figure B.19, while more detailed information can be found in Appendix C of TM 5.2 (see Volume 5).

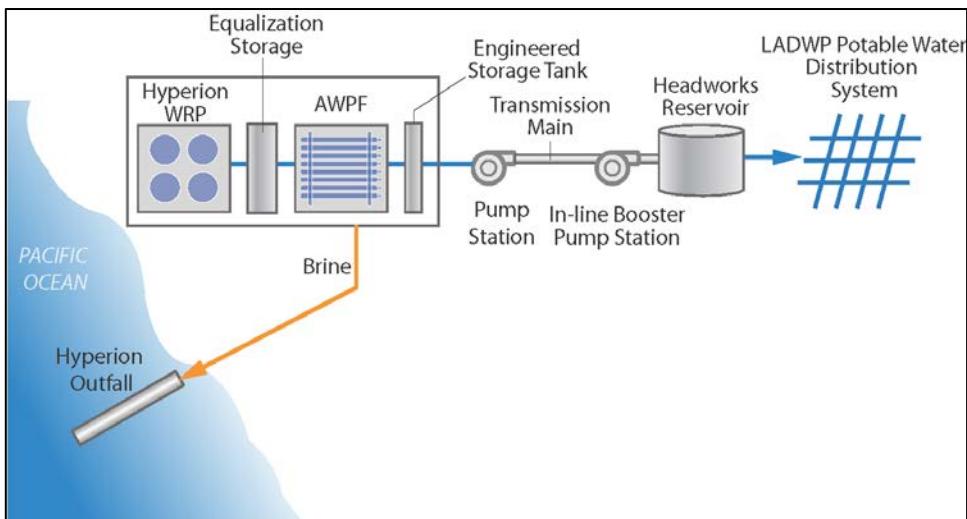

Figure B.19 - Hyperion WRP to Headworks Reservoir

Concept Option 20, Hyperion WRP to Los Angeles Aqueduct Filtration Plant

Treat Hyperion Water Reclamation Plant (HWRP) effluent at an Advanced Water Purification Facility (AWPF) and pump water over the Santa Monica Mountains to the LA Aqueduct Filtration Plant (LAAFP). The estimated yield is 95,000 AFY under normal year conditions, while the unit cost is estimated to be roughly \$2,600 per AF. The concept flow schematic is shown on Figure B.20, while more detailed information can be found in Appendix C of TM 5.2 (see Volume 5).

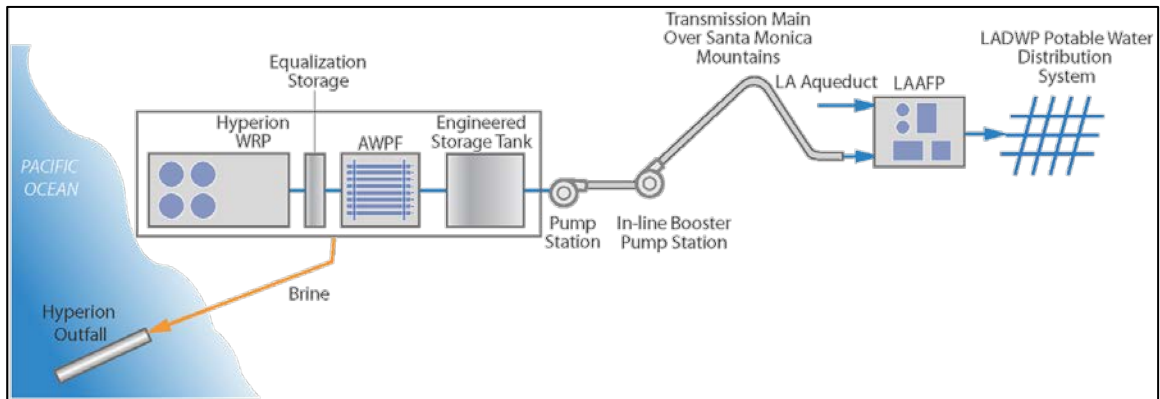

Figure B.20 - Hyperion WRP to Los Angeles Aqueduct Filtration Plant

Concept Option 21, Central LA Satellite WRP to Los Angeles Aqueduct Filtration Plant

Construct a new satellite treatment plant in Central LA (downtown or mid-City). Collect wastewater flows at the satellite plant and at an Advanced Water Purification Facility (AWPF) and pump water over the Santa Monica Mountains to the LA Reservoir or LA Aqueduct Filtration Plant (LAAFP). The estimated yield is 95,000 AFY under normal year conditions, while the unit cost is estimated to be roughly \$3,400 per AF. The concept flow schematic is shown on Figure B.21, while more detailed information can be found in Appendix C of TM 5.2 (see Volume 5).

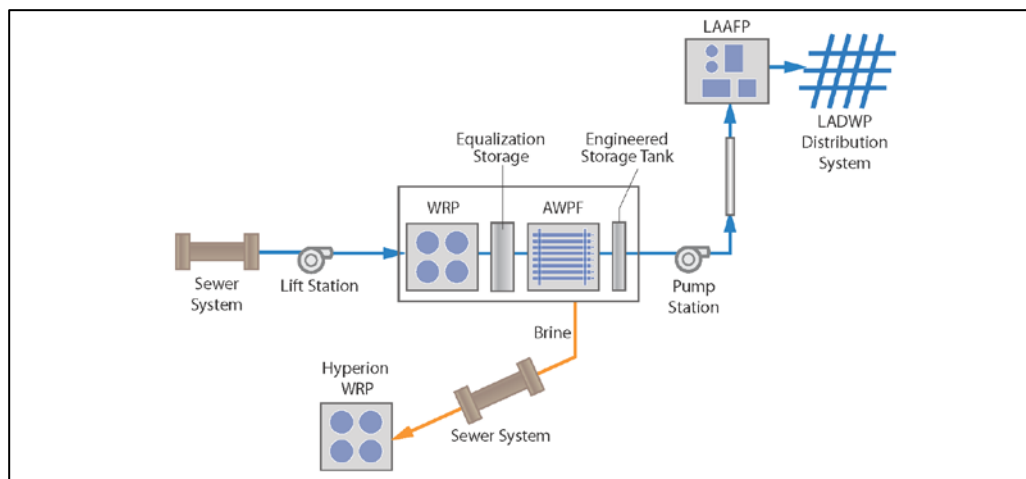

Figure B.21 - Central LA Satellite WRP to Los Angeles Aqueduct Filtration Plant

Concept Option 22, East-West Valley Interceptor Sewer

Construct the East-West Valley Interceptor Sewer (EWWIS) and transfer 12,800 AFY (15.9 mgd) to Donald C. Tillman Water Reclamation Plant (DCTWRP). The estimated yield is 12,780 AFY under normal year conditions, while the unit cost is estimated to be roughly \$430 per AF. The concept flow schematic is shown on Figure B.22, while more detailed information can be found in Appendix C of TM 5.2 (see Volume 5).

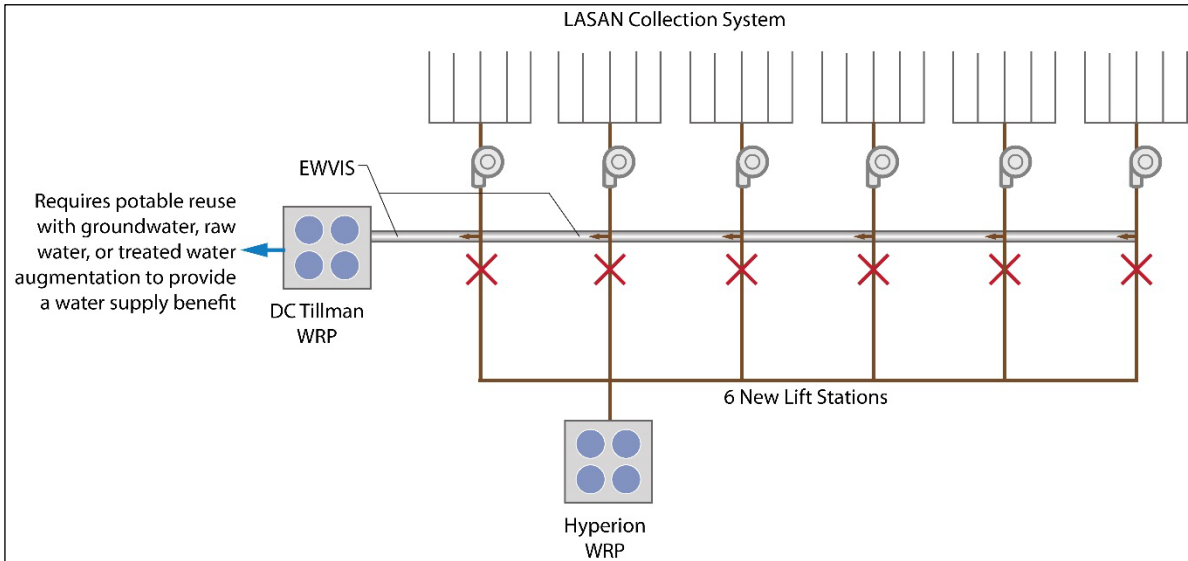

Figure B.22 - East-West Valley Interceptor Sewer

Concept Option 23, Increase Recycled Water Demand beyond 2015 UWMP

Non-potable reuse (NPR) purple pipe system expansion near Terminal Island Water Reclamation Plant (TIWRP), Hyperion Water Reclamation Plant (HWRP), and Donald C. Tillman Water Reclamation Plant (DCTWRP). The estimated yield is 16,700 AFY under normal year conditions, while the unit cost is estimated to be roughly \$2,100 per AF. The concept flow schematic is shown on Figure B.23, while more detailed information can be found in Appendix C of TM 5.2 (see Volume 5).

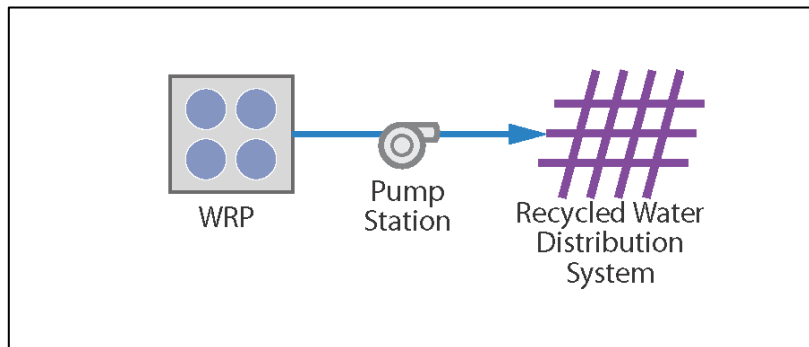

Figure B.23 - Increase Recycled Water Demand beyond 2015 UWMP

Concept Option 24, Rancho Park Water Reclamation Facility

Construct a water reclamation facility and deliver a combination of recycled water and stormwater to serve local non-potable reuse water demands. The estimated yield for all three phases is up to 3,600 AFY under normal year conditions, while the unit cost is estimated to be roughly \$180 million or \$2,900 per AF. The estimated capital cost for all three phases is used in the future integration opportunity discussion because the ultimate build-out capacity is provided for all future concepts. The estimated capital cost for the first phase of the facility is \$58 million for an estimated yield of 1,860 AFY. The costs for the first phase of the facility do not include the required LADWP recycled water distribution piping. The concept flow schematic is shown on Figure B.24, while more detailed information can be found in Appendix C of TM 5.2 (see Volume 5).

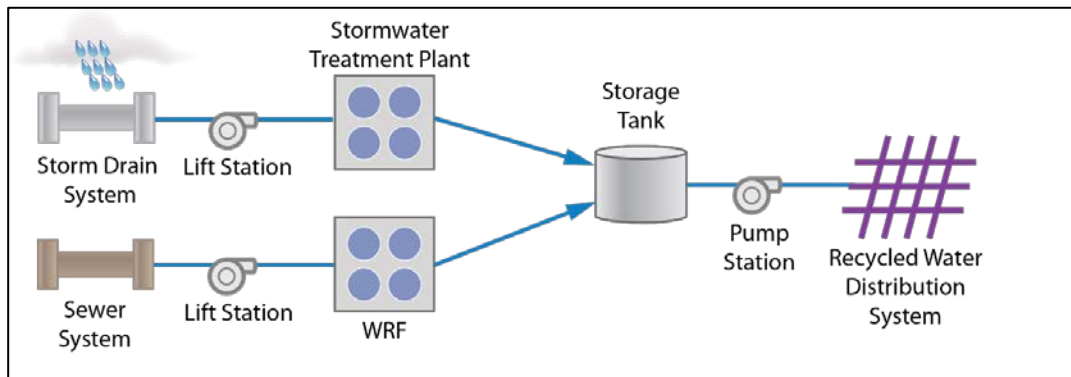

Figure B.24 - Rancho Park Water Reclamation Facility

Concept Option 25, Ocean Desalination

Ocean desalination from the Santa Monica Bay; delivering water directly to the LADWP or regional distribution system. The estimated yield is 28,000 AFY under normal year conditions, while the unit cost is estimated to be roughly \$2,100 per AF. The concept flow schematic is shown on Figure B.25, while more detailed information can be found in Appendix C of TM 5.2 (see Volume 5).

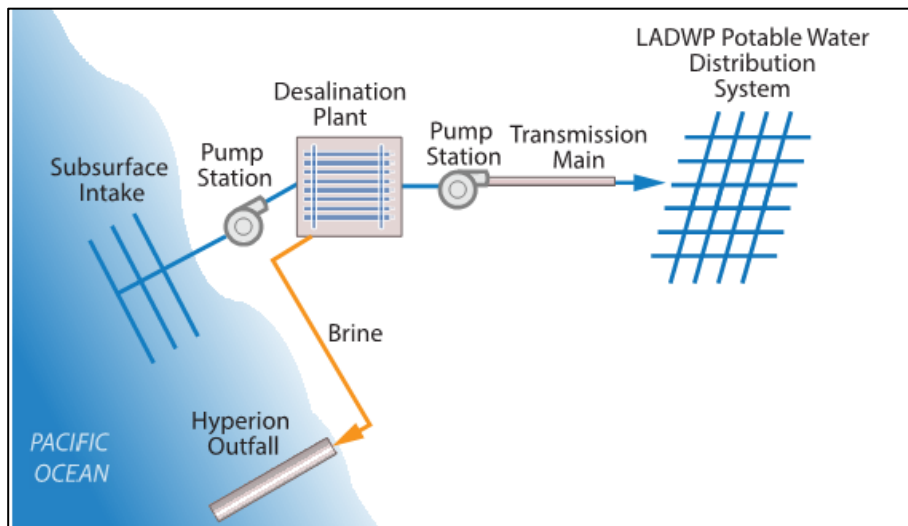

Figure B.25 - Ocean Desalination

Concept Option 26, Japanese Garden & Sepulveda Basin Lakes Recirculation

Recycle flows from Lake Balboa, Japanese Gardens, and Wildlife Lake to Tillman WRP. The estimated yield is 20,000 AFY under normal year conditions, while the unit cost is estimated to be roughly \$50 per AF. The concept flow schematic is shown on Figure B.26, while more detailed information can be found in Appendix C of TM 5.2 (see Volume 5).

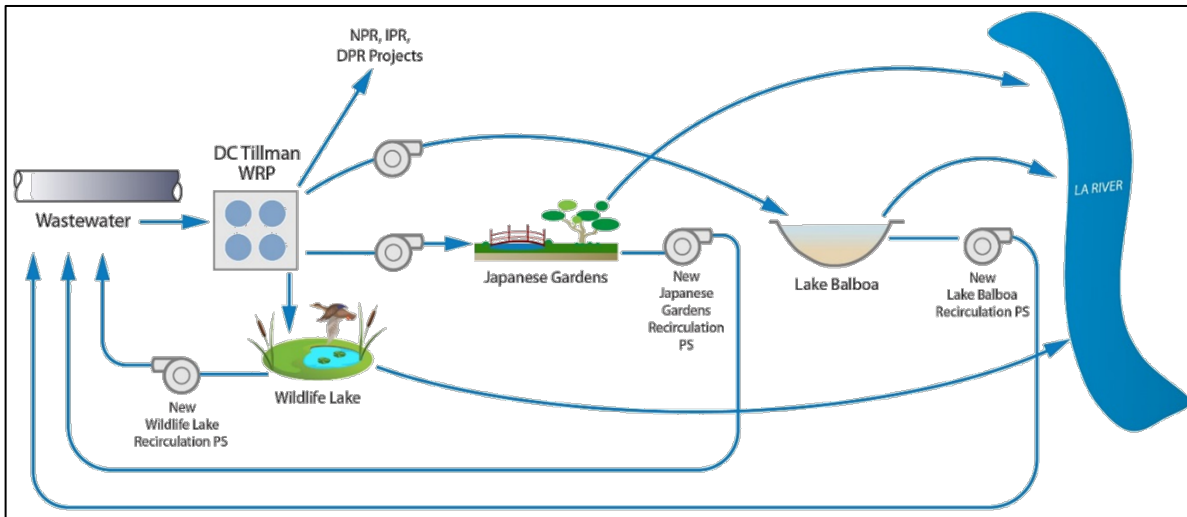

Figure B.26 - Japanese Garden & Sepulveda Basin Lakes Recirculation

APPENDIX C – WASTEWATER PROJECTS

C.1 Wastewater Facilities Plan (WWFP) Capital Improvement Program (CIP) Details

Tables C.1-C.5 detail the WWFP CIP information discussed in Chapter 7.

-This Page Left Blank Intentionally-

Table C.1 HWRP Projected CIP Wastewater Facilities Plan - One Water LA 2040 Plan									
Approved CIP	BOE CIP#	LASAN CIP#	Project Title	Project Phase	Project Type	Near-Term 2018-2020	Mid-Term 2021-2030	Long-Term 2031-2040	Project Cost (\$)
X	2253	197	IPS Odor Control Improvements	Near	Capital Project	\$5,100,000			\$5,100,000
X	2371	855	Abrasive Blast and Steam Cleaning Facility	Near	R&R	\$3,248,000			\$3,248,000
X	2376	901	Dilute Polymer System Improvements	Mid	R&R		\$6,890,000		\$6,890,000
X	2413		DSF Improvements	Mid	R&R		\$5,305,000		\$5,305,000
X	2426	1289	FOG Receiving Station North	Near	Capital Project	\$4,994,000			\$4,994,000
X	2438	1387	Secondary Clarifiers Upgrade Modules 1-5	Near	R&R	\$13,473,000			\$13,473,000
X	2439		ELC Equipment Upgrades	Mid	R&R		\$500,000		\$500,000
X	2441	1444	Digester Corrosion Rehabilitation	Near	R&R	\$8,990,000			\$8,990,000
X	2443	1440	FeCl ₂ Injection Facility Replacement	Near	R&R	\$2,050,000			\$2,050,000
X	2445	1441	Primary Tanks B0, B5, & C0 Upgrades	Near	Capital Project	\$2,918,000			\$2,918,000
X	2446	1442	Primary Tanks Skimmer Improvements	Near	R&R	\$7,860,000			\$7,860,000
X	2447	1481	Plant Perimeter Road Improvements	Near	R&R	\$390,000			\$390,000
X	2448		Cryo Facility Upgrade	Mid	R&R		\$50,000,000		\$50,000,000

Approved CIP	BOE CIP#	LASAN CIP#	Project Title	Project Phase	Project Type	Near-Term 2018-2020	Mid-Term 2021-2030	Long-Term 2031-2040	Project Cost (\$)
X	2451	1548	Digester Battery E Improvements	Near	R&R	\$13,964,000			\$13,964,000
X	2454	1578	Biosolids Pumping System Upgrades	Near	R&R	\$7,210,000			\$7,210,000
X	2455	1579	Digester Equipment Improvements Battery - D3 (Battery E), D2, D1	Mid	R&R		\$9,000,000		\$9,000,000
X	2456		Oxygen Reactor Improvements Modules 1-4	Near	Capital Project	\$7,000,000			\$7,000,000
X	2457	1608	Equipment Storage Facility	Mid	R&R		\$3,000,000		\$3,000,000
X	2459		TSF Mechanical Equipment Upgrades	Near	R&R	\$5,000,000			\$5,000,000
X	2460	1610	Replace Ferric Chloride Facility	Near	R&R	\$1,676,000			\$1,676,000
X	2466		Headworks Fire Sprinkler Rehabilitation and Recoating	Near	R&R	\$1,000,000			\$1,000,000
X	2468		Parking Structure Crack Repair and Sprinkler Repair	Near	R&R	\$762,000			\$762,000
X	2470		Harrington Bldg Air Quality Improvements	Near	R&R	\$976,000			\$976,000
X	2471		Pregerson Bldg Interior Refurbishment	Near	R&R	\$627,000			\$627,000

Table C.1 HWRP Projected CIP Wastewater Facilities Plan - One Water LA 2040 Plan									
Approved CIP	BOE CIP#	LASAN CIP#	Project Title	Project Phase	Project Type	Near-Term 2018-2020	Mid-Term 2021-2030	Long-Term 2031-2040	Project Cost (\$)
X	2474		Headworks Bar Screen Sluice Gate Replacements	Near	R&R	\$4,713,000			\$4,713,000
X	2477		Primary Influent Sluice Gates	Mid	R&R		\$10,000,000		\$10,000,000
X	2478		Oxygen Reactor Improvements Modules 5-9	Mid	Capital Project		\$8,000,000		\$8,000,000
X	2480		Headworks Truck Loading Area Odor Control Upgrades	Near	R&R	\$940,000			\$940,000
X	2481		Service Water Facility Improvements	Near	R&R	\$1,704,000			\$1,704,000
X	2483		Primary Batteries for Odor Control Facility Upgrades	Mid	Capital Project		\$23,000,000		\$23,000,000
X	8079		LPGH No. 1 Rehabilitation	Near	R&R	\$98,000			\$98,000
X	8143		Central Storm Drain Rerouting	Near	R&R	\$3,420,000			\$3,420,000
X	8147		LPGH Safety & Process Improvement	Near	R&R	\$228,000			\$228,000
X	8152		Aqueous Ammonia Storage & Spill Containment Enhancements	Near	R&R	\$1,699,000			\$1,699,000
X	8155		Liquid Oxygen Tank No. 2 Rehabilitation	Near	R&R	\$450,000			\$450,000

Approved CIP	BOE CIP#	LASAN CIP#	Project Title	Project Phase	Project Type	Near-Term 2018-2020	Mid-Term 2021-2030	Long-Term 2031-2040	Project Cost (\$)
X	8156		Cryogenic Facility Technical Assessment	Near	R&R	\$681,000			\$681,000
X	8157		Flare System Access Platforms and Knockout Drum	Near	R&R	\$556,000			\$556,000
X	8159		Headworks Grit Classifier Upgrade	Near	R&R	\$449,000			\$449,000
X	8160		Headworks Bar Screen Sluice Gate Replacements Channel 1 & 10	Near	R&R	\$913,000			\$913,000
X	8161		Emergency Bypass Channel Rehabilitation	Near	R&R	\$500,000			\$500,000
X	8162		Industrial Water Distribution Modification	Near	R&R	\$565,000			\$565,000
	8165		Screw Pump #6 Gearbox Total Bearing Replacement	Near	R&R	\$150,000			\$150,000
X	8166		Truck Loading Facility Enhancement	Near	Capital Project	\$200,000			\$3,420,000
X	8179		Low Pressure Gas Holder #1	Near	R&R	\$610,000			\$228,000
			Slope Stabilization	Near	Climate Change	\$600,000			\$600,000
Total						\$106M	\$116M		\$222M

Approved CIP	BOE CIP#	LASAN CIP#	Project Title	Project Phase	Project Type	Near-Term 2018-2020	Mid-Term 2021-2030	Long-Term 2031-2040	Project Cost (\$)
X	6122	1385	Channel 1 Air Spargers Improvements	Near	Capital Project	\$865,000			\$865,000
X	6145		Backup Power Generation	Near	Climate Resilience	\$7,713,000			\$7,713,000
X	6192	1187	Multi-Purpose and Office Building	Near	Capital Project	\$19,980,000			\$19,980,000
X	6194	1337	Multi-Purpose and Office Building Exhibits	Near/Mid	Capital Project	\$1,325,000	\$1,325,000		\$2,650,000
X	6195	1211	Maintenance Facility Expansion	Near	Capital Project	\$28,000,000			\$28,000,000
X	6204	1467	Chemical Lines Upgrade	Near	R&R	\$1,150,000			\$1,150,000
X	6205	1459	Berm Improvements	Near	Climate Resilience	\$4,500,000			\$4,500,000
X	6207		Secondary Clarifier Improvement	Near/Mid	Capital Project	\$5,450,000	\$5,450,000		\$10,900,000
X	6209		Stormwater Interim Treatment System	Near	Capital Project	\$1,000,000	\$1,000,000		
X	6214		Administration Building HVAC Replacement	Near	R&R	\$2,882,000			\$2,882,000
X	6215	1596	Phase 1 Bar Screens	Mid	Capital Project		\$1,590,000		\$1,590,000

Approved CIP	BOE CIP#	LASAN CIP#	Project Title	Project Phase	Project Type	Near-Term 2018-2020	Mid-Term 2021-2030	Long-Term 2031-2040	Project Cost (\$)
X	6216	1597	Influent Meter and Channel 2 Dump Gate Meter	Near	Capital Project	\$836,000			\$836,000
X	6217	1598	Primary Settling Tanks Improvements	Mid	Capital Project		\$12,000,000		\$12,000,000
X	6223	1604	Administration Building Improvements	Near	R&R	\$2,000,000			\$2,000,000
X	6226	1571	Chlorination System Improvements	Near	Capital Project	\$1,794,000			\$1,794,000
X	6231		AVORS & EVIS Gates Replacement	Near	R&R	\$1,300,000			\$1,300,000
X	6232		Underground HPE/LPE Improvements	Near	Capital Project	\$1,434,000			\$1,434,000
X	6233		Disinfection System Conversion of NaOCl to UV	Long	Capital Project			\$10,300,000	\$10,300,000
X	6234		Screw Pump Inlet Gates	Near	Capital Project	\$1,215,000			\$1,215,000
X	8626		LAB Building Roof Protection System	Near	Capital Project	\$96,000			\$96,000
X	8637		Primary Tank HPE Piping Replacement	Near	R&R	\$895,000			\$895,000
X	8638		Niwa Road Sewer Installation	Near	Capital Project	\$293,000			\$293,000

Approved CIP	BOE CIP#	LASAN CIP#	Project Title	Project Phase	Project Type	Near-Term 2018-2020	Mid-Term 2021-2030	Long-Term 2031-2040	Project Cost (\$)
X	8640	1471	Niwa Road Parking*	Near	Capital Project	\$250,000			\$250,000
X	8645	1573	Odor Masking Systems Replacement*	Near	Capital Project	\$98,000			\$98,000
X	8646		Lab Building Winch	Near	Capital Project	\$50,000			\$50,000
X	8649		DCTWRP Chlorine Contact Tank HPE System Actuators	Near	R&R	\$1,109,000			\$1,109,000
X	8650		Japanese Garden Electrical System Improvements	Near	R&R	\$295,000			\$295,000
X	8651		Japanese Garden Pond Foundation Improvements*	Near	R&R	\$500,000			\$500,000
X	8654		Japanese Garden ADA Compliance	Near		\$578,000			\$578,000
X	8655		RAS Ph. 1 & Ph. 2 Tie-In*	Near	Capital Project	\$245,000			\$245,000
X			Interim Ozone	Near	Capital Project	\$60,000,000			
Total						\$146M	\$21.3M	\$10.3M	\$177.6M

Approved CIP	BOE CIP#	LASAN CIP#	Project Title	Project Phase	Project Type	Near-Term 2018-2020	Mid-Term 2021-2030	Long-Term 2031-2040	Project Cost (\$)
X	4170	1307	Personnel Building	Near	R&R	\$14,044,000			\$14,044,000
X	4172		Headworks Improvements	Near	R&R	\$2,814,000			\$2,814,000
X	4176		Primary Effluent Equalization Storage	Near	Capital Project	\$17,041,000			\$17,041,000
X	4177	1458	Stormwater Interim Treatment System	Mid	Capital Project		\$1,000,000		
X	4178	1472	Dechlorination Chamber Improvements	Near	R&R	\$1,436,000			\$1,436,000
X	4179		Bisulfite Facility Improvements	Near	R&R	\$1,350,000			\$1,350,000
X	4184		Influent Pumps Replacement	Mid	R&R		\$3,500,000		\$3,500,000
X	4185	1616	Grit Removal System Upgrade	Mid	R&R		\$1,500,000		\$1,500,000
X	4187	1620	Blower Air Cleanup System	Near	R&R	\$2,201,000			\$2,201,000
X	4188	1621	Primary Settling System Rehabilitation	Mid	R&R		\$10,000,000		
X	4189	1622	Cover Plates & Grating Replacement	Near	R&R	\$1,070,000			\$1,070,000
X	4190	1623	Secondary Activated Sludge Reactors Rehabilitation	Near	R&R	\$7,000,000			\$7,000,000

Approved CIP	BOE CIP#	LASAN CIP#	Project Title	Project Phase	Project Type	Near-Term 2018-2020	Mid-Term 2021-2030	Long-Term 2031-2040	Project Cost (\$)
X	4191	1624	Secondary Clarifiers Rehabilitations	Near	R&R	\$6,000,000			\$6,000,000
X	4195	1627	LAG Storage Building	Near	R&R	\$1,500,000			\$1,500,000
X	4199		Tertiary Filter Upgrade	Near	R&R	\$1,500,000			\$1,500,000
X	4200		Sodium Hypochlorite Facility Relocation	Near	R&R	\$1,176,000			\$1,176,000
X	8420		Blower No. 1 Inlet Air Supply	Near	R&R	\$95,000			\$95,000
X	8421		Primary Cover Plates & Grating Replacement	Near	R&R	\$471,000			\$471,000
X	8422		Tertiary Filter Guard Rail Replacement	Near	R&R	\$40,000			\$40,000
X		8417	Maintenance Building Locker Room Improvements	Near	R&R	\$179,000			\$179,000
			Backup Power Generation	Near	Climate Resilience	\$4,000,000			\$4,000,000
			Backflow Prevention Gates	Near	Climate Resilience	\$400,000			\$400,000
			Floodwalls	Near	Climate Resilience	\$10,000,000			\$10,000,000
Total						\$72M	\$16M		\$88M

Approved CIP	BOE CIP#	LASAN CIP#	Project Title	Project Phase	Project Type	Near-Term 2018-2020	Mid-Term 2021-2030	Long-Term 2031-2040	Project Cost (\$)
X	3335	268	Power/Energy MGMT	Near	Capital Project	\$494,000			\$494,000
X	5182	744	Fire Protect SYS REPL	Mid	R&R		\$1,120,000		\$1,120,000
X	5198	1015	Service Maintenance & Warehouse Facility	Near	R&R	\$15,278,000			\$15,278,000
X	5202	1332	Blending Tank Rehabilitation	Near	R&R	\$1,719,000			\$1,719,000
X	5223	1340	Tire Facility Enhancement	Near	Capital Project	\$3,180,000			\$3,180,000
X	5224	1317	Daft Modification	Near	R&R	\$907,000			\$907,000
X	5228	1327	Biogas System Conditioning	Near	Capital Project	\$1,773,000			\$1,773,000
X	5238		Machado Lake De-Chlorination Station	Near	Capital Project	\$1,477,000			\$1,477,000
X	5242	1581	Phase I AWPf Membrane Replacement	Near	R&R	\$18,290,000			\$18,290,000
X	5243	1582	Digester Gas Utilization System	Near	Capital Project	\$5,000,000			\$5,000,000
X	5244	1583	AWPF Emergency Generators	Near	Capital Project	\$3,000,000			\$3,000,000
X	5245	1584	Digester Insulation Replacement	Mid	R&R		\$6,180,000		\$6,180,000
X	5246	1585	Learning Center	Mid	Capital Project		\$7,725,000		\$7,725,000

Approved CIP	BOE CIP#	LASAN CIP#	Project Title	Project Phase	Project Type	Near-Term 2018-2020	Mid-Term 2021-2030	Long-Term 2031-2040	Project Cost (\$)
X	5247	1586	Primary Treatment Process Modernization	Mid	R&R		\$8,240,000		\$8,240,000
X	5248	1587	Digester Gas Compressor Replacement	Long	R&R			\$2,928,000	\$2,928,000
X	5249	1588	EPP Piping System Improvements	Near	Capital Project	\$1,113,000			\$1,113,000
X	5251	1591	AWPF Enhancement	Mid	Capital Project		\$10,000,000		\$10,000,000
X	5254		Admin Building Refurbishment	Near	R&R	\$2,000,000			\$2,000,000
X	5255		Final Tanks Skimmer System Upgrade	Near	R&R	\$2,894,000			\$2,894,000
X	5256		HPE and Brine Separation	Near	R&R	\$500,000			\$500,000
X	5257		Headworks Odor Control	Near	R&R	\$5,000,000			\$5,000,000
X	7166		SW – Bureau Wide Security System	Long	R&R			\$2,648,000	\$2,648,000
X	8532		High Pressure Gas Holder Rehabilitation	Near	R&R	\$350,000			\$350,000
X	8533	1594	Truck Scale Relocation	Near	R&R	\$500,000			\$500,000

Approved CIP	BOE CIP#	LASAN CIP#	Project Title	Project Phase	Project Type	Near-Term 2018-2020	Mid-Term 2021-2030	Long-Term 2031-2040	Project Cost (\$)
X	8534	1595	Site & Drainage Improvements	Near	R&R	\$368,000			\$368,000
X	8537		Emergency Generator Controls Upgrade	Near	Capital Project	\$1,061,000			\$1,061,000
X		1592	Grit Pump Room Ventilation System	Long	R&R			\$1,474,000	\$1,474,000
X		1443	Electricity Usage Monitoring and Optimization	Long	R&R			\$5,417,000	\$5,417,000
			Floodwalls	Long	Climate Resilience			\$10,000,000	\$10,000,000
			Backup Power Generation	Long	Climate Resilience			\$4,000,000	\$4,000,000
Total						\$65M	\$33M	\$26.4M	\$125M

Approved CIP	Plant No./ Project No.	Project Title	Project Phase	Project Type	Near-Term 2018-2020	Mid-Term 2021-2030	Long-Term 2031-2040	Project Cost (\$)
X	250	SSRP T07 AVALON AND LOMITA	Near	R&R	\$1,744,000			\$1,744,000
	614	Tuxford (LFD)	Near	Climate Resilience	\$90,000			\$90,000
	624	Roscomare	Near	Climate Resilience	\$20,000			\$20,000
	634	Temescal	Near	Climate Resilience	\$60,000			\$60,000
	639	North Pulga	Near	Climate Resilience	\$60,000			\$60,000
	646	Venice Pumping Plant	Long	Climate Resilience			\$1,600,000	\$1,600,000
	647	Kinney Circle	Near	Climate Resilience	\$610,000			
	648	Thompson	Long	Climate Resilience			\$480,000	\$480,000
	649	Jefferson	Long	Climate Resilience			\$80,000	\$80,000
	666	Fries Ave	Mid	Climate Resilience		\$1,110,000		
	668	Henry Ford	Near	Climate Resilience	\$230,000			
	669	Harris Place	Long	Climate Resilience			\$810,000	\$810,000
	671	Terminal Way	Long	Climate Resilience			\$1,070,000	\$1,070,000

Approved CIP	Plant No./ Project No.	Project Title	Project Phase	Project Type	Near-Term 2018-2020	Mid-Term 2021-2030	Long-Term 2031-2040	Project Cost (\$)
	672	Murdock & I	Long	Climate Resilience			\$720,000	\$720,000
	676	Mcfarland	Long	Climate Resilience			\$1,020,000	\$1,020,000
	677	Hawaiian & "B"	Long	Climate Resilience			\$870,000	\$870,000
	680	22nd & Signal	Long	Climate Resilience			\$126,000	\$126,000
	681	Ports 'O' Call	Long	Climate Resilience			\$340,000	\$340,000
	683	22nd Street	Long	Climate Resilience			\$500,000	\$500,000
	684	Miner	Long	Climate Resilience			\$500,000	\$500,000
	685	Signal	Long	Climate Resilience			\$480,000	\$480,000
	686	Nissan Way	Long	Climate Resilience			\$490,000	\$490,000
	687	North Neptune	Mid	Climate Resilience		\$400,000		\$400,000
	689	Seaside	Long	Climate Resilience			\$600,000	\$600,000
	690	Anchorage	Long	Climate Resilience			\$300,000	\$300,000
	691	San Pedro	Long	Climate Resilience			\$1,080,000	\$1,080,000

Approved CIP	Plant No./ Project No.	Project Title	Project Phase	Project Type	Near-Term 2018-2020	Mid-Term 2021-2030	Long-Term 2031-2040	Project Cost (\$)
	733	Santa Monica	Near	Climate Resilience	\$140,000			\$140,000
	734	Temescal	Near	Climate Resilience	\$60,000			\$60,000
	740	Westside Park	Near	Climate Resilience	\$90,000			\$90,000
X	6205	SSRP W20 VENTURA AND TAMPA	Near	R&R	\$2,643,000			\$2,643,000
X	7181	PP677 HAWAIIAN & B REHAB	Near	R&R	\$1,430,000			\$1,430,000
X	7182	PP676 WILMINGTON REHAB	Near	R&R	\$1,523,000			\$1,523,000
X	7183	PP666 FRIES REHAB	Near	R&R	\$1,532,000			\$1,532,000
X	7184	PP604 Highbury REHAB	Near	R&R	\$2,205,000			\$2,205,000
X	7185	PP671 TERMINAL WAY REHAB	Near	R&R	\$2,824,000			\$2,824,000
X	7186	PP691 SAN PEDRO REHAB	Near	R&R	\$2,335,000			\$2,335,000
X	7187	ODOR CNTR MLK & RODEO FAC UPG	Near	Capital Project	\$850,000			\$850,000
X	7188	ODOR CTR NORS-ECIS SCR FAC UPG	Near	Capital Project	\$1,026,000			\$1,026,000
X	7190	ODOR CNTR RADFORD SCR FB FAC UPG	Near	Capital Project	\$1,121,000			\$1,121,000

Approved CIP	Plant No./ Project No.	Project Title	Project Phase	Project Type	Near-Term 2018-2020	Mid-Term 2021-2030	Long-Term 2031-2040	Project Cost (\$)
X	7191	ODOR CTR RICHMOND SCRUB FAC UPG	Near	Capital Project	\$1,302,000			\$1,302,000
X	7192	ODOR CNTRL NOTF SCRUBBER UPG	Near	Capital Project	\$1,302,000			\$1,302,000
X	7193	ODOR CTR SIERRA BONITA FAC UPG	Near	Capital Project	\$1,302,000			\$1,302,000
X	7194	ODOR CTR HUMBOLDT SCRUB FAC UPG	Near	Capital Project	\$1,302,000			\$1,302,000
X	7195	ODOR CNT BALLONA SCRUB FAC UPG	Near	Capital Project	\$1,121,000			\$1,121,000
X	7196	ODOR CNTR DACOTAH SCRUB FAC UPG	Near	Capital Project	\$747,000			\$747,000
X	7198	NCOS JEFFERSON HOLDREDGE VAULT	Near	R&R	\$722,000			\$722,000
X	7199	ODOR CTRL GENESEE SCRUB FAC INS	Near	Capital Project	\$320,000			\$320,000
X	7222	PP646 VENICE GENERATORS REPL	Near	R&R	\$5,039,000			\$5,039,000
X	7223	PP674 190 & VERMONT GEN REPL	Near	R&R	\$502,000			\$502,000
X	7229	PP672 MURDOCK & I GEN REPL	Near	R&R	\$382,000			\$382,000
X	7230	PP601 MANCHESTER GEN REPL	Near	R&R	\$1,043,000			\$1,043,000

Approved CIP	Plant No./ Project No.	Project Title	Project Phase	Project Type	Near-Term 2018-2020	Mid-Term 2021-2030	Long-Term 2031-2040	Project Cost (\$)
X	7231	PP606 DACOTAH GENERATORS REPL	Near	R&R	\$747,000			\$747,000
X	7232	PP669 HARRIS PL GENERATR REPL	Near	R&R	\$388,000			\$388,000
X	7237	PP NORTH YARD GENERATOR REPL	Near	R&R	\$472,000			\$472,000
X	7238	PP WEST LA YARD GEN REPL	Near	R&R	\$109,000			\$109,000
X	7239	PP616 CAHUENGA GEN REPL	Near	R&R	\$156,000			\$156,000
X	7240	PP624 ROSCOMARE GEN REPL	Near	R&R	\$156,000			\$156,000
X	7241	PP632 SUNSET GEN REPL	Near	R&R	\$700,000			\$700,000
X	7242	PP638 PALISADES GEN REPL	Near	R&R	\$393,000			\$393,000
X	7243	PP648 THOMPSON YARD GEN REPL	Near	R&R	\$397,000			\$397,000
X	7244	PP654 BALLONA CREEK GEN REPL	Near	R&R	\$2,852,000			\$2,852,000
X	7249	PP601 MANCHESTER IMPROVEMENTS	Near	R&R	\$650,000			\$650,000
X	7250	GENESEE CARBON SCRUBBER PROC	Near	R&R	\$754,000			\$754,000
X	7252	SAN PEDRO PP FORCE MAIN MOD	Near	Capital Project	\$69,000			\$69,000

Approved CIP	Plant No./ Project No.	Project Title	Project Phase	Project Type	Near-Term 2018-2020	Mid-Term 2021-2030	Long-Term 2031-2040	Project Cost (\$)
X	C191	PP VENICE DUAL FORCE MAIN	Near	Capital Project	\$88,300,000			\$88,300,000
X	C195	PP VENICE DISCHARGE MANIF REPL	Near	R&R	\$5,834,000			\$5,834,000
X	C245	HIGHLAND PK EAGLE ROCK SWR RHB	Near	R&R	\$1,837,000			\$1,837,000
X	C263	SLAUSON COMPTON SWR REHAB	Near	R&R	\$16,794,000			\$16,794,000
X	C278	WILSHIRE AREA OLYM SWR REHAB	Near	R&R	\$1,081,000			\$1,081,000
X	C279	WILSHIRE AREA SYSSWR REHAB	Near	R&R	\$4,843,000			\$4,843,000
X	C689	UPPER BEACHWOOD EASEMNT MH ADD	Near	Capital Project	\$871,000			\$871,000
X	C707	NOS REHAB U-1 VAN NESS WESTERN	Near	R&R	\$9,182,000			\$9,182,000
X	C728	ENTERPRISE ST SIPHON MOD	Near	R&R	\$1,770,000			\$1,770,000
X	C771	SAN PEDRO SIPHON UPSTREAM 30"	Near	R&R	\$2,013,000			\$2,013,000
X	C782	NORMANDIE SWR REPL/REHAB	Near	R&R	\$10,007,000			\$10,007,000
X	C812	NOS REHAB U-3 VERMONT TO TRIN	Near	R&R	\$13,519,000			\$13,519,000
X	C815	NOS REHAB U-6 HOOPER WILSON	Near	R&R	\$10,609,000			\$10,609,000

Approved CIP	Plant No./ Project No.	Project Title	Project Phase	Project Type	Near-Term 2018-2020	Mid-Term 2021-2030	Long-Term 2031-2040	Project Cost (\$)
X	C816	NOS REHAB U-7 WILSON LA RIVER	Near	R&R	\$7,498,000			\$7,498,000
X	C817	NOS REHAB U-8 6TH TO 8TH ST RW	Near	R&R	\$10,995,000			\$10,995,000
X	C818	NOS REHAB U-9 ALISO TO 6TH	Near	R&R	\$12,530,000			\$12,530,000
X	C821	NOS REHAB U-12 DUVAL HUMBOLDT	Mid	R&R		\$14,600,000		\$14,600,000
X	C822	NOS REHAB U-13 FORNEY TO DUVAL	Near	R&R	\$15,103,000			
X	C826	NOS REHAB U-18 COLORADO DORAN	Near	R&R	\$12,781,000			\$12,781,000
X	C851	SSRP H31 BEACHWOOD & SCENIC	Near	R&R	\$5,786,000			\$5,786,000
X	C865	CONCORD STREET RELIEF SWR	Mid	Capital Project		\$3,500,000		\$3,500,000
X	C866	PIERCE & WOODMAN DIVERSION SWR	Near	Capital Project	\$558,000			\$558,000
X	C867	ARLINGTON/JEFFERS ON DVRSN SWR	Near	R&R	\$1,794,000			\$1,794,000
X	C868	VENICE BLVD INTERCEPTOR U2	Near	Capital Project	\$9,333,000			\$9,333,000
X	C872	SSRP N03 ADAMS BL & COMPTON AV	Near	R&R	\$940,000			\$940,000
X	C873	SSRP N06A 36TH PL & VERMONT	Near	R&R	\$524,000			\$524,000

Approved CIP	Plant No./ Project No.	Project Title	Project Phase	Project Type	Near-Term 2018-2020	Mid-Term 2021-2030	Long-Term 2031-2040	Project Cost (\$)
X	C874	SSRP N06B ADAMS & HILL	Near	R&R	\$943,000			\$943,000
X	C878	SSRP H11 BURNSIDE & WILSHIRE	Near	R&R	\$436,000			\$436,000
X	C879	SSRP N07 BROADWAY & PICO	Near	R&R	\$6,054,000			\$6,054,000
X	C882	SSRP S07 76TH ST & GRAND AVE	Near	R&R	\$192,000			\$192,000
X	C883	SSRP S08 MAIN & MANCHESTER	Near	R&R	\$809,000			\$809,000
X	C892	SSRP S14 HOOVER & VERNON	Near	R&R	\$1,685,000			\$1,685,000
X	C894	SSRP P17 CYPRESS & DIVISION	Near	R&R	\$5,719,000			\$5,719,000
X	C895	SSRP P20 COLORADO & TOWNSEND	Near	R&R	\$1,813,000			\$1,813,000
X	C896	SSRP Z18A CENTURY & MAIN	Near	R&R	\$2,730,000			\$2,730,000
X	C897	SSRP Z18B IMPERIAL & AVALON	Near	R&R	\$1,796,000			\$1,796,000
X	C898	LCIS REHAB BLACKWELDER OLYMPIC	Near	R&R	\$22,528,000			\$22,528,000
X	C911	SSRP P07 HUNTINGTON & POPLAR	Near	R&R	\$1,751,000			\$1,751,000

Approved CIP	Plant No./ Project No.	Project Title	Project Phase	Project Type	Near-Term 2018-2020	Mid-Term 2021-2030	Long-Term 2031-2040	Project Cost (\$)
X	C912	DOWNTOWN & ECHO PARK SWR REHAB	Near	R&R	\$2,455,000			\$2,455,000
X	C913	SSRP P19 FIGUEROA & YOSEMITE	Near	R&R	\$5,003,000			\$5,003,000
X	C914	DAR 03 EAGLE ROCK & LOS FELIZ	Near	R&R	\$6,707,000			\$6,707,000
X	C917	SSRP N09 LORENA & WHITTIER	Near	R&R	\$2,897,000			\$2,897,000
X	C918	SSRP P06 EL SERENO & EDISON	Near	R&R	\$8,682,000			\$8,682,000
X	C919	SSRP S13 VERNON & BUDLONG	Near	R&R	\$1,103,000			\$1,103,000
X	C920	SSRP P08 DALY ST & AVENUE 26	Near	R&R	\$1,985,000			\$1,985,000
X	C921	JEF BUDLONG GRAMERCY SWR REHAB	Near	R&R	\$555,000			\$555,000
X	C922	VENICE AUXILIARY PUMPING PLANT	Near	Capital Project	\$17,029,000			\$17,029,000
X	C923	CHANDLER LANKERSHIM SWR IMP	Near	R&R	\$2,844,000			\$2,844,000
X	C924	DAR 04 EAGLE ROCK & LINCOLN HT	Near	R&R	\$5,532,000			\$5,532,000
X	C925	SSRP N14 TEMPLE & GLENDALE	Near	R&R	\$2,894,000			\$2,894,000

Approved CIP	Plant No./ Project No.	Project Title	Project Phase	Project Type	Near-Term 2018-2020	Mid-Term 2021-2030	Long-Term 2031-2040	Project Cost (\$)
X	C926	COCHRAN ADAMS RELIEF SEWER	Near	Capital Project	\$7,520,000			\$7,520,000
X	C927	SSRP P04 MISSION & SOTO	Near	R&R	\$3,843,000			\$3,843,000
X	C928	SSRP H22 MELROSE & WILTON	Near	R&R	\$2,489,000			\$2,489,000
X	C929	SSRP Z24 LA BREA & 63RD	Near	R&R	\$577,000			\$577,000
X	C930	SSRP P22 VERDUGO & PALMER	Mid	R&R		\$2,400,000		\$2,400,000
X	C931	ARLINGTON AVE SEWER REHAB	Near	R&R	\$9,516,000			\$9,516,000
X	C934	SSRP P01A RIVERSIDE & DORRIS	Near	R&R	\$5,289,000			\$5,289,000
X	C935	LCIS U 7-8 REHAB AL VISTA VINE	Near	R&R	\$2,817,000			\$2,817,000
X	C937	SSRP P01B DALY & NORTH MAIN	Mid	R&R		\$3,900,000		\$3,900,000
X	C938	SSRP N04 WASHINGTON & SOTO	Near	R&R	\$1,921,000			\$1,921,000
X	C939	SSRP U07 CENTINELA & IDAHO	Near	R&R	\$732,000			\$732,000
X	C940	SSRP N11 7TH ST & VALENCIA ST	Near	R&R	\$2,605,000			\$2,605,000
X	C941	SSRP H09 PICO & HAUSER	Near	R&R	\$1,228,000			\$1,228,000

Approved CIP	Plant No./ Project No.	Project Title	Project Phase	Project Type	Near-Term 2018-2020	Mid-Term 2021-2030	Long-Term 2031-2040	Project Cost (\$)
X	C942	SAN FERNANDO RD RELIEF SEWER	Near	Capital Project	\$73,600,000			\$73,600,000
X	C944	NAOMI AVENUE SEWER UPSIZING	Near	Capital Project	\$6,234,000			\$6,234,000
X	C946	DAR 05 HOLLYWOOD/WILSHIRE	Near	R&R	\$4,749,000			\$4,749,000
X	C947	DAR 06 NORTHEAST LOS ANGELES	Mid	R&R		\$11,940,000		\$11,940,000
X	C948	SSRP C05 LINCOLN BL & ROSE AVE	Near	R&R	\$1,565,000			
X	C949	SSRP E20 VENTURA & KESTER	Mid	R&R		\$10,500,000		\$10,500,000
X	C950	SSRP N10 PICO BL & UNION AVE	Near	R&R	\$4,623,000			\$4,623,000
X	C951	74TH ST SWR REHAB UNIT 1	Near	R&R	\$9,258,000			\$9,258,000
X	C952	SSRP A05 111TH ST & LA CIENEGA	Near	R&R	\$2,211,000			\$2,211,000
X	C953	SSRP H07 WASHINGTON & HAUSER	Near	R&R	\$638,000			\$638,000
X	C954	SSRP P02 CESAR CHAVEZ & SOTO	Near	R&R	\$3,993,000			\$3,993,000
X	C959	DAR 08 WESTCHESTER AND WILSHIRE	Mid	R&R		\$7,000,000		\$7,000,000

Approved CIP	Plant No./ Project No.	Project Title	Project Phase	Project Type	Near-Term 2018-2020	Mid-Term 2021-2030	Long-Term 2031-2040	Project Cost (\$)
X	C969	SSRP W33 VENTURA AND GLADE	Near	R&R	\$2,436,000			
X	C972	SSRP H08 21 ST AND LA BREA AVE	Near	R&R	\$545,000			
X	C973	DAR 07A N HOLLYWOOD SUNLAND	Mid	R&R		\$5,300,000		\$5,300,000
X	G623	MAINTENANCE YARD-SOUTH DST	Near	Capital Project	\$8,420,000			\$8,420,000
X	G672	MAINTENANCE YARD-HOLLYWOOD FAC	Near	Capital Project	\$7,963,000			\$7,963,000
X	G673	MAINTENANCE YARD-N HOLLYWOOD	Mid	Capital Project		\$9,300,000		\$9,300,000
X	Sanc0085	MAINTENANCE HOLE RESETTING	Near	R&R	\$18,572,000			
X	ZOO	LA Zoo	Near	Climate Resilience	\$960,000			
X		MAINTENANCE YARD-RESEDA	Near	Capital Project	\$7,562,000			
X		NOS REHAB U-28 101 FWY TO BECK	Long	R&R			\$11,000,000	\$11,000,000
X		NOS REHAB PROGRAM	Near	R&R	\$21,373,000			\$21,373,000
X		NOS REHAB U-4: 41ST TO 23RD	Near	R&R	\$16,302,000			\$16,302,000
X		NOS REHAB U-14 MARSH ST FORNEY	Near	R&R	\$13,951,000			\$13,951,000

Approved CIP	Plant No./ Project No.	Project Title	Project Phase	Project Type	Near-Term 2018-2020	Mid-Term 2021-2030	Long-Term 2031-2040	Project Cost (\$)
X		SSRP Z28 ROSECRANS AND VERMONT	Near	R&R	\$2,248,000			\$2,248,000
X		SSRP E10 FOOTHILL & COMMERCE	Near	R&R	\$1,518,000			\$1,518,000
X		SSRP E06 LA TUNA CANYON	Near	R&R	\$727,000			\$727,000
X		SSRP W34 BURBANK BL SHOUP AVE	Near	R&R	\$716,000			\$716,000
X		PP654 BALLONA CREEK REHAB	Near	R&R	\$250,000			\$250,000
X		PP602 UNION PACIF REHAB	Near	R&R	\$105,000			\$105,000
X		MAINTENANCE YARD-WLA FACILITY	Mid	Capital Project		\$7,800,000		\$7,800,000
Total					\$641M	\$79M	\$22M	\$741M

-This Page Left Blank Intentionally-

APPENDIX D – STORMWATER PROJECTS

Project Name	Watershed	Lead Agency	Project Type	Project Category	Project Size	Known Water Quality Benefit?	Known Water Supply Benefit?	Known Flood Risk Mitigation Benefit?	Other Considerations	Green Infrastructure Capital Cost	Grey Infrastructure Capital Cost	Annual O&M Cost	Selection Order	SIP Phase
Lafayette Park	BC	LASAN	City	Green Infrastructure	Centralized	Yes	Yes	Yes	Funding	\$ 26,833,381	\$ -	\$ 1,341,669	1	5 Year
Westlake EWMP Regional Project 1	BC	LASAN	City	Green Infrastructure	Centralized	Yes	Yes	Yes	Funding	\$ 4,914,204	\$ -	\$ 245,710	1	5 Year
Wilshire EWMP Regional Project 1	BC	LASAN	City	Green Infrastructure	Centralized	Yes	Yes	Yes	Funding	\$ 2,722,501	\$ -	\$ 136,125	1	5 Year
Wilshire EWMP Regional Project 2	BC	LASAN	City	Green Infrastructure	Centralized	Yes	Yes	Yes	Funding	\$ 2,628,495	\$ -	\$ 131,425	1	5 Year
South Los Angeles EWMP Regional Project 2	BC	LASAN	City	Green Infrastructure	Centralized	Yes	Yes	Yes	Funding	\$ 4,184,084	\$ -	\$ 209,204	1	5 Year
Wilshire EWMP Regional Project 3	BC	LASAN	City	Green Infrastructure	Centralized	Yes	Yes	Yes	Funding	\$ 3,813,562	\$ -	\$ 190,678	1	5 Year
Southeast Los Angeles EWMP Regional Project 1	BC	LASAN	City	Green Infrastructure	Centralized	Yes	Yes	Yes	Funding	\$ 3,353,197	\$ -	\$ 167,660	1	5 Year
Westlake EWMP Regional Project 2	BC	LASAN	City	Green Infrastructure	Centralized	Yes	Yes	Yes	Funding	\$ 3,353,196	\$ -	\$ 167,660	1	5 Year
Wilshire EWMP Regional Project 4	BC	LASAN	City	Green Infrastructure	Centralized	Yes	Yes	Yes	Funding	\$ 1,858,547	\$ -	\$ 92,927	1	5 Year
South Los Angeles EWMP Regional Project 5	BC	LASAN	City	Green Infrastructure	Centralized	Yes	Yes	Yes	Funding	\$ 1,048,186	\$ -	\$ 52,409	1	5 Year
South Los Angeles EWMP Regional Project 6	BC	LASAN	City	Green Infrastructure	Centralized	Yes	Yes	Yes	Funding	\$ 2,808,987	\$ -	\$ 140,449	1	5 Year
South Los Angeles EWMP Regional Project 7	BC	LASAN	City	Green Infrastructure	Centralized	Yes	Yes	Yes	Funding	\$ 2,624,499	\$ -	\$ 131,225	1	5 Year
Wilshire EWMP Regional Project 5	BC	LASAN	City	Green Infrastructure	Centralized	Yes	Yes	Yes	Funding	\$ 2,634,427	\$ -	\$ 131,721	1	5 Year
Poinsettia Park	BC	LASAN	City	Green Infrastructure	Centralized	Yes	Yes	Yes	Funding	\$ 14,860,528	\$ -	\$ 743,026	1	5 Year
Hollywood EWMP Regional Project 1	BC	LASAN	City	Green Infrastructure	Centralized	Yes	Yes	Yes	Funding	\$ 3,069,712	\$ -	\$ 153,486	1	5 Year
Hollywood EWMP Regional Project 2	BC	LASAN	City	Green Infrastructure	Centralized	Yes	Yes	Yes	Funding	\$ 3,069,712	\$ -	\$ 153,486	1	5 Year
South Los Angeles EWMP Regional Project 8	BC	LASAN	City	Green Infrastructure	Centralized	Yes	Yes	Yes	Funding	\$ 2,514,321	\$ -	\$ 125,716	1	5 Year
Westlake EWMP Regional Project 3	BC	LASAN	City	Green Infrastructure	Centralized	Yes	Yes	Yes	Funding	\$ 2,297,473	\$ -	\$ 114,874	1	5 Year
South Los Angeles EWMP Regional Project 9	BC	LASAN	City	Green Infrastructure	Centralized	Yes	Yes	Yes	Funding	\$ 2,240,406	\$ -	\$ 112,020	1	5 Year
South Los Angeles EWMP Regional Project 10	BC	LASAN	City	Green Infrastructure	Centralized	Yes	Yes	Yes	Funding	\$ 2,243,042	\$ -	\$ 112,152	1	5 Year
Wilshire EWMP Regional Project 6	BC	LASAN	City	Green Infrastructure	Centralized	Yes	Yes	Yes	Funding	\$ 482,990	\$ -	\$ 24,150	1	5 Year
Wilshire EWMP Regional Project 7	BC	LASAN	City	Green Infrastructure	Centralized	Yes	Yes	Yes	Funding	\$ 363,548	\$ -	\$ 18,177	1	5 Year
Hollywood EWMP Regional Project 3	BC	LASAN	City	Green Infrastructure	Centralized	Yes	Yes	Yes	Funding	\$ 2,225,580	\$ -	\$ 111,279	1	5 Year
Westlake EWMP Regional Project 4	BC	LASAN	City	Green Infrastructure	Centralized	Yes	Yes	Yes	Funding	\$ 289,685	\$ -	\$ 14,484	1	5 Year
West Adams EWMP Regional Project 12	BC	LASAN	City	Green Infrastructure	Centralized	Yes	Yes	Yes	Funding	\$ 1,965,317	\$ -	\$ 98,266	1	5 Year
Westlake EWMP Regional Project 5	BC	LASAN	City	Green Infrastructure	Centralized	Yes	Yes	Yes	Funding	\$ 2,039,729	\$ -	\$ 101,986	1	5 Year
Wilshire EWMP Regional Project 9	BC	LASAN	City	Green Infrastructure	Centralized	Yes	Yes	Yes	Funding	\$ 1,791,401	\$ -	\$ 89,570	1	5 Year
West Adams EWMP Regional Project 13	BC	LASAN	City	Green Infrastructure	Centralized	Yes	Yes	Yes	Funding	\$ 1,780,949	\$ -	\$ 89,047	1	5 Year
South Los Angeles EWMP Regional Project 16	BC	LASAN	City	Green Infrastructure	Centralized	Yes	Yes	Yes	Funding	\$ 1,774,701	\$ -	\$ 88,735	1	5 Year
Vermont Square Park Stormwater Treatment and Infiltration Project	BC	LASAN	City	Green Infrastructure	Centralized	Yes	Yes	Yes	Funding	\$ 2,113,088	\$ -	\$ 105,654	1	5 Year
Hollywood EWMP Regional Project 4	BC	LASAN	City	Green Infrastructure	Centralized	Yes	Yes	Yes	Funding	\$ 218,755	\$ -	\$ 10,938	1	5 Year
Southeast Los Angeles EWMP Regional Project 2	BC	LASAN	City	Green Infrastructure	Centralized	Yes	Yes	Yes	Funding	\$ 1,734,988	\$ -	\$ 86,749	1	5 Year
Hollywood EWMP Regional Project 6	BC	LASAN	City	Green Infrastructure	Centralized	Yes	Yes	Yes	Funding	\$ 1,728,626	\$ -	\$ 86,431	1	5 Year
Wilshire EWMP Regional Project 11	BC	LASAN	City	Green Infrastructure	Centralized	Yes	Yes	Yes	Funding	\$ 1,748,334	\$ -	\$ 87,417	1	5 Year
Hollywood EWMP Regional Project 8	BC	LASAN	City	Green Infrastructure	Centralized	Yes	Yes	Yes	Funding	\$ 1,739,972	\$ -	\$ 86,999	1	5 Year
National Boulevard Runoff Treatment Project	BC	LASAN	City	Green Infrastructure	Centralized	Yes	Yes	Yes	Funding	\$ 14,111,000	\$ -	\$ 705,550	1	5 Year
Hollywood EWMP Regional Project 10	BC	LASAN	City	Green Infrastructure	Centralized	Yes	Yes	Yes	Funding	\$ 1,692,946	\$ -	\$ 84,647	1	5 Year
Hollywood EWMP Regional Project 11	BC	LASAN	City	Green Infrastructure	Centralized	Yes	Yes	Yes	Funding	\$ 1,691,758	\$ -	\$ 84,588	1	5 Year
Wilshire EWMP Regional Project 13	BC	LASAN	City	Green Infrastructure	Centralized	Yes	Yes	Yes	Funding	\$ 1,672,617	\$ -	\$ 83,631	1	5 Year
LA River Segment B Urban Runoff Project No. 1	ULAR	LASAN	City	Green Infrastructure	Centralized	Yes	Yes	Yes	Funding	\$ 7,809,000	\$ -	\$ 390,450	1	5 Year
LA River Segment B Urban Runoff Project No. 2	ULAR	LASAN	City	Green Infrastructure	Centralized	Yes	Yes	Yes	Funding	\$ 7,398,000	\$ -	\$ 369,900	1	5 Year
2-2 Parking Lot	SMB	LASAN	City	Green Infrastructure	Centralized	Yes	Yes	Yes	Funding	\$ 5,334,119	\$ -	\$ 266,706	1	5 Year
Rustic Canyon Recreation Center	SMB	LASAN	City	Green Infrastructure	Centralized	Yes	Yes	Yes	Funding	\$ 3,150,439	\$ -	\$ 157,522	1	5 Year
North Hollywood Park Project	ULAR	LASAN/LADWP	City	Green Infrastructure	Centralized	Yes	Yes	Yes	Funding	\$ 6,067,730	\$ -	\$ 303,387	1	5 Year
Southeast Los Angeles EWMP Project 1	ULAR	LASAN	City	Green Infrastructure	Centralized	Yes	Yes	Yes	Funding	\$ 4,110,000	\$ -	\$ 205,500	1	5 Year
Sunland EWMP Regional Project 1	ULAR	LASAN	City	Green Infrastructure	Centralized	Yes	Yes	Yes	Funding	\$ 5,428,026	\$ -	\$ 271,401	1	5 Year
Sun Valley EWMP Regional Project 1	ULAR	LASAN	City	Green Infrastructure	Centralized	Yes	Yes	Yes	Funding	\$ 2,452,026	\$ -	\$ 122,601	1	5 Year
Sun Valley EWMP Regional Project 2	ULAR	LASAN	City	Green Infrastructure	Centralized	Yes	Yes	Yes	Funding	\$ 4,832,753	\$ -	\$ 241,638	1	5 Year
Reseda EWMP Regional Project 1	ULAR	LASAN	City	Green Infrastructure	Centralized	Yes	Yes	Yes	Funding	\$ 288,325	\$ -	\$ 14,416	1	5 Year
North Hollywood EWMP Regional Project 2	ULAR	LASAN	City	Green Infrastructure	Centralized	Yes	Yes	Yes	Funding	\$ 9,387,523	\$ -	\$ 469,376	1	5 Year
Reseda EWMP Regional Project 2	ULAR	LASAN	City	Green Infrastructure	Centralized	Yes	Yes	Yes	Funding	\$ 3,516,106	\$ -	\$ 175,805	1	5 Year
North Hollywood EWMP Regional Project 3	ULAR	LASAN	City	Green Infrastructure	Centralized	Yes	Yes	Yes	Funding	\$ 7,619,640	\$ -	\$ 380,982	1	5 Year
Sun Valley EWMP Project 5	ULAR	LASAN	City	Green Infrastructure	Centralized	Yes	Yes	Yes	Funding	\$ 3,476,256	\$ -	\$ 173,813	1	5 Year
Chase St. Priority Greenway + Bull Creek Park	ULAR	LASAN	City	Green Infrastructure	Centralized	Yes	Yes	Yes	Funding	\$ 3,145,839	\$ -	\$ 157,292	1	5 Year
Canoga Park EWMP Regional Project 1	ULAR	LASAN	City	Green Infrastructure	Centralized	Yes	Yes	Yes	Funding	\$ 3,070,170	\$ -	\$ 153,509	1	5 Year
Reseda EWMP Regional Project 3	ULAR	LASAN	City	Green Infrastructure	Centralized	Yes	Yes	Yes	Funding	\$ 18,917,242	\$ -	\$ 945,862	1	5 Year
Encino EWMP Regional Project 2	ULAR	LASAN	City	Green Infrastructure	Centralized	Yes	Yes	Yes	Funding	\$ 5,518,228	\$ -	\$ 275,911	1	5 Year
Aliso Creek - Limekiln Creek Restoration	ULAR	LASAN	City	Green Infrastructure	Centralized	Yes	Yes	Yes	Funding	\$ 6,287,740	\$ -	\$ 314,387	1	5 Year
Boyle Heights Jonit Use Community Center	ULAR	LASAN	City	Green Infrastructure	Centralized	Yes	Yes	Yes	Funding	\$ 10,275,000	\$ -	\$ 513,750	1	5 Year
Fernangeles Park/Recreation Center	ULAR	LASAN/LADWP	City	Green Infrastructure	Centralized	Yes	Yes	Yes	Funding - LADWP	\$ 14,000,000	\$ -	\$ 700,000	1	5 Year
Old Pacoima Wash Stormwater Capture	ULAR	LACFCD/ LADWP	Partner	Green Infrastructure	Centralized	Yes	Yes	Yes	Funding - LADWP	\$ 40,000,000	\$ -	\$ 2,000,000	1	5 Year
Hancock Park Drainage Improvement Project	BC	LACFCD/ LABOE	Partner	Green - Grey Infrastructure	Centralized	Yes	Yes	Yes	Open Space and Recreation	\$ 10,000,000	\$ -	\$ 500,000	1	5 Year
Storm Drain Mining (Inject)	BC	LADWP	City	Green Infrastructure	Centralized	Yes	Yes	Yes	Funding-LADWP	\$ 300,000	\$ -	\$ 15,000	1	5 Year
Arundo Donax Removal Project - Phase I	ULAR	Others - NFF/LADWP	Partner	Green Infrastructure	Centralized	Yes	Yes	Yes	Funding - LADWP	\$ 6,300,000	\$ -	\$ 315,000	2	5 Year
Arundo Donax Removal Project - Phase II	ULAR	Others - NFF/LADWP	Partner	Green Infrastructure	Centralized	Yes	Yes	Yes	Funding - LADWP	\$ 2,340,000	\$ -	\$ 117,000	2	5 Year
East Valley Baseball Park (Strathern Park)	ULAR	LASAN/LADWP/RAP	City	Green Infrastructure	Centralized	Yes	Yes	No	Funding - LADWP	\$ 12,000,000	\$ -	\$ 44,450	3	5 Year

Project Name	Watershed	Lead Agency	Project Type	Project Category	Project Size	Known Water Quality Benefit?	Known Water Supply Benefit?	Known Flood Risk Mitigation Benefit?	Other Considerations	Green Infrastructure Capital Cost	Grey Infrastructure Capital Cost	Annual O&M Cost	Selection Order	SIP Phase
San Fernando Gardens SWCP	ULAR	LASAN/LADWP	City	Green Infrastructure	Centralized	Yes	Yes	No	Funding - LADWP	\$ 1,062,500	\$ -	\$ 53,125	3	5 Year
San Fernando Regional Park	ULAR	LASAN/LADWP	City	Green Infrastructure	Centralized	Yes	Yes	No	Funding - LADWP	\$ 10,000,000	\$ -	\$ 500,000	3	5 Year
Whitsett Sports Field	ULAR	LASAN/LADWP/RAP	City	Green Infrastructure	Centralized	Yes	Yes	No	Funding - LADWP	\$ 13,000,000	\$ -	\$ 40,000	3	5 Year
Bradley Plaza	ULAR	LADWP	City	Green Infrastructure	Centralized	Yes	Yes	No		\$ 500,000	\$ -	\$ 25,000	3	5 Year
Whitnall Highwall Power Line Easement Recharge	ULAR	LADWP	City	Green Infrastructure	Centralized	Yes	Yes	No		\$ 30,000,000	\$ -	\$ 100,000	3	5 Year
Palms EWMP Regional Project 1	BC	LASAN	City	Green Infrastructure	Centralized	Yes	Yes	Yes	Funding	\$ 12,026,075	\$ -	\$ 601,304	4	5 Year
South Los Angeles EWMP Regional Project 1	BC	LASAN	City	Green Infrastructure	Centralized	Yes	Yes	Yes	Funding	\$ 3,229,412	\$ -	\$ 161,471	4	5 Year
West Adams EWMP Regional Project 1	BC	LASAN	City	Green Infrastructure	Centralized	Yes	Yes	Yes	Funding	\$ 7,730,833	\$ -	\$ 386,542	4	5 Year
West Los Angeles EWMP Regional Project 1	BC	LASAN	City	Green Infrastructure	Centralized	Yes	Yes	Yes	Funding	\$ 6,150,441	\$ -	\$ 307,522	4	5 Year
West Adams EWMP Regional Project 2	BC	LASAN	City	Green Infrastructure	Centralized	Yes	Yes	Yes	Funding	\$ 2,053,915	\$ -	\$ 102,696	4	5 Year
Queen Anne Recreation Center	BC	LASAN	City	Green Infrastructure	Centralized	Yes	Yes	Yes	Funding	\$ 36,485,036	\$ -	\$ 1,824,252	4	5 Year
West Adams EWMP Regional Project 3	BC	LASAN	City	Green Infrastructure	Centralized	Yes	Yes	Yes	Funding	\$ 5,420,202	\$ -	\$ 271,010	4	5 Year
West Adams EWMP Regional Project 4	BC	LASAN	City	Green Infrastructure	Centralized	Yes	Yes	Yes	Funding	\$ 4,569,195	\$ -	\$ 228,460	4	5 Year
West Los Angeles EWMP Regional Project 2	BC	LASAN	City	Green Infrastructure	Centralized	Yes	Yes	Yes	Funding	\$ 4,112,530	\$ -	\$ 205,627	4	5 Year
Palms EWMP Regional Project 2	BC	LASAN	City	Green Infrastructure	Centralized	Yes	Yes	Yes	Funding	\$ 1,429,801	\$ -	\$ 71,490	4	5 Year
West Los Angeles EWMP Regional Project 3	BC	LASAN	City	Green Infrastructure	Centralized	Yes	Yes	Yes	Funding	\$ 1,553,317	\$ -	\$ 77,666	4	5 Year
South Los Angeles EWMP Regional Project 3	BC	LASAN	City	Green Infrastructure	Centralized	Yes	Yes	Yes	Funding	\$ 3,195,652	\$ -	\$ 159,783	4	5 Year
West Los Angeles EWMP Regional Project 4	BC	LASAN	City	Green Infrastructure	Centralized	Yes	Yes	Yes	Funding	\$ 3,243,304	\$ -	\$ 162,165	4	5 Year
Rancho Park Golf Course	BC	LASAN	City	Green Infrastructure	Centralized	Yes	Yes	Yes	Funding	\$ 17,838,568	\$ -	\$ 891,928	4	5 Year
West Adams EWMP Regional Project 5	BC	LASAN	City	Green Infrastructure	Centralized	Yes	Yes	Yes	Funding	\$ 1,272,923	\$ -	\$ 63,646	4	5 Year
West Adams EWMP Regional Project 6	BC	LASAN	City	Green Infrastructure	Centralized	Yes	Yes	Yes	Funding	\$ 1,141,797	\$ -	\$ 57,090	4	5 Year
West Los Angeles EWMP Regional Project 5	BC	LASAN	City	Green Infrastructure	Centralized	Yes	Yes	Yes	Funding	\$ 3,558,279	\$ -	\$ 177,914	4	5 Year
South Los Angeles EWMP Regional Project 4	BC	LASAN	City	Green Infrastructure	Centralized	Yes	Yes	Yes	Funding	\$ 1,175,007	\$ -	\$ 58,750	4	5 Year
West Los Angeles EWMP Regional Project 6	BC	LASAN	City	Green Infrastructure	Centralized	Yes	Yes	Yes	Funding	\$ 3,044,104	\$ -	\$ 152,205	4	5 Year
West Adams EWMP Regional Project 7	BC	LASAN	City	Green Infrastructure	Centralized	Yes	Yes	Yes	Funding	\$ 552,077	\$ -	\$ 27,604	4	5 Year
West Los Angeles EWMP Regional Project 7	BC	LASAN	City	Green Infrastructure	Centralized	Yes	Yes	Yes	Funding	\$ 2,502,661	\$ -	\$ 125,133	4	5 Year
Silver Lake EWMP Regional Project 1	BC	LASAN	City	Green Infrastructure	Centralized	Yes	Yes	Yes	Funding	\$ 3,011,731	\$ -	\$ 150,587	4	5 Year
Palms EWMP Regional Project 3	BC	LASAN	City	Green Infrastructure	Centralized	Yes	Yes	Yes	Funding	\$ 470,108	\$ -	\$ 23,505	4	5 Year
West Adams EWMP Regional Project 8	BC	LASAN	City	Green Infrastructure	Centralized	Yes	Yes	Yes	Funding	\$ 579,012	\$ -	\$ 28,951	4	5 Year
West Adams EWMP Regional Project 9	BC	LASAN	City	Green Infrastructure	Centralized	Yes	Yes	Yes	Funding	\$ 349,029	\$ -	\$ 17,451	4	5 Year
South Los Angeles EWMP Regional Project 11	BC	LASAN	City	Green Infrastructure	Centralized	Yes	Yes	Yes	Funding	\$ 2,049,722	\$ -	\$ 102,486	4	5 Year
West Adams EWMP Regional Project 10	BC	LASAN	City	Green Infrastructure	Centralized	Yes	Yes	Yes	Funding	\$ 323,072	\$ -	\$ 16,154	4	5 Year
West Adams EWMP Regional Project 11	BC	LASAN	City	Green Infrastructure	Centralized	Yes	Yes	Yes	Funding	\$ 2,233,457	\$ -	\$ 111,673	4	5 Year
South Los Angeles EWMP Regional Project 12	BC	LASAN	City	Green Infrastructure	Centralized	Yes	Yes	Yes	Funding	\$ 307,840	\$ -	\$ 15,392	4	5 Year
South Los Angeles EWMP Regional Project 13	BC	LASAN	City	Green Infrastructure	Centralized	Yes	Yes	Yes	Funding	\$ 276,909	\$ -	\$ 13,845	4	5 Year
South Los Angeles EWMP Regional Project 14	BC	LASAN	City	Green Infrastructure	Centralized	Yes	Yes	Yes	Funding	\$ 1,934,319	\$ -	\$ 96,716	4	5 Year
Palms EWMP Regional Project 4	BC	LASAN	City	Green Infrastructure	Centralized	Yes	Yes	Yes	Funding	\$ 296,394	\$ -	\$ 14,820	4	5 Year
West Los Angeles EWMP Regional Project 9	BC	LASAN	City	Green Infrastructure	Centralized	Yes	Yes	Yes	Funding	\$ 183,476	\$ -	\$ 9,174	4	5 Year
Westchester EWMP Regional Project 2	BC	LASAN	City	Green Infrastructure	Centralized	Yes	Yes	Yes	Funding	\$ 1,767,931	\$ -	\$ 88,397	4	5 Year
Palms EWMP Regional Project 6	BC	LASAN	City	Green Infrastructure	Centralized	Yes	Yes	Yes	Funding	\$ 1,754,106	\$ -	\$ 87,705	4	5 Year
West Adams EWMP Regional Project 14	BC	LASAN	City	Green Infrastructure	Centralized	Yes	Yes	Yes	Funding	\$ 1,716,934	\$ -	\$ 85,847	4	5 Year
South Los Angeles EWMP Regional Project 19	BC	LASAN	City	Green Infrastructure	Centralized	Yes	Yes	Yes	Funding	\$ 1,732,116	\$ -	\$ 86,606	4	5 Year
West Los Angeles EWMP Regional Project 11	BC	LASAN	City	Green Infrastructure	Centralized	Yes	Yes	Yes	Funding	\$ 1,683,719	\$ -	\$ 84,186	4	5 Year
West Adams EWMP Regional Project 16	BC	LASAN	City	Green Infrastructure	Centralized	Yes	Yes	Yes	Funding	\$ 1,670,986	\$ -	\$ 83,549	4	5 Year
Wilmington Recreation Center Project Site	DC	LASAN	City	Green Infrastructure	Centralized	Yes	Yes	Yes	Funding	\$ 1,013,239	\$ -	\$ 50,662	4	5 Year
Averill Park Project Site	DC	LASAN	City	Green Infrastructure	Centralized	Yes	Yes	Yes	Funding	\$ 29,548,160	\$ -	\$ 1,477,408	4	5 Year
Via Dolce Park	SMB	LASAN	City	Green Infrastructure	Centralized	Yes	Yes	Yes	Funding	\$ 9,117,877	\$ -	\$ 455,894	4	5 Year
Canal Park	SMB	LASAN	City	Green Infrastructure	Centralized	Yes	Yes	Yes	Funding	\$ 467,757	\$ -	\$ 23,388	4	5 Year
Triangle Park	SMB	LASAN	City	Green Infrastructure	Centralized	Yes	Yes	Yes	Funding	\$ 95,251	\$ -	\$ 4,763	4	5 Year
Venice of America Centennial Park	SMB	LASAN	City	Green Infrastructure	Centralized	Yes	Yes	Yes	Funding	\$ 592,826	\$ -	\$ 29,641	4	5 Year
Mandeville	SMB	LASAN	City	Green Infrastructure	Centralized	Yes	Yes	Yes	Funding	\$ 2,965,161	\$ -	\$ 148,258	4	5 Year
Brentwood Country Club	SMB	LASAN	City	Green Infrastructure	Centralized	Yes	Yes	Yes	Funding	\$ 62,835,255	\$ -	\$ 3,141,763	4	5 Year
Riviera Country Club	SMB	LASAN	City	Green Infrastructure	Centralized	Yes	Yes	Yes	Funding	\$ 7,661,069	\$ -	\$ 383,053	4	5 Year
Santa Monica Bay Low Flow Diversion Enhancement Project	SMB	LASAN	City	Green Infrastructure	Centralized	Yes	Yes	Yes	Funding	\$ 7,144,530	\$ -	\$ 357,227	4	5 Year
Santa Ynez Canyon BMP Project	SMB	LASAN	City	Green Infrastructure	Centralized	Yes	Yes	Yes	Funding	\$ 72,750	\$ -	\$ 3,638	4	5 Year
Westchester Recreation Center	SMB	LASAN	City	Green Infrastructure	Centralized	Yes	Yes	Yes	Funding	\$ 17,729,143	\$ -	\$ 886,457	4	5 Year
NOTF/LFTF-1 Phase I	BC	LASAN	City	Green Infrastructure	Centralized	Yes	Yes	Yes	Funding	\$ 17,971,391	\$ -	\$ 898,570	4	5 Year
Sepulveda Channel Diversion BMP Project	BC	LASAN	City	Green Infrastructure	Centralized	Yes	Yes	Yes	Funding	\$ 16,968,820	\$ -	\$ 848,441	4	5 Year
Proposed LFD - Pump 609	ULAR	LASAN	City	Grey Infrastructure	Centralized	Yes	Yes	No	Funding	\$ -	\$ 3,000,000	\$ 150,000	5	5 Year
Proposed LFD - Pump 617	ULAR	LASAN	City	Grey Infrastructure	Centralized	Yes	Yes	No	Funding	\$ -	\$ 3,000,000	\$ 150,000	5	5 Year
Proposed LFD - Pump 619	ULAR	LASAN	City	Grey Infrastructure	Centralized	Yes	Yes	No	Funding	\$ -	\$ 3,000,000	\$ 150,000	5	5 Year
Proposed LFD - Pump 620	ULAR	LASAN	City	Grey Infrastructure	Centralized	Yes	Yes	No	Funding	\$ -	\$ 3,000,000	\$ 150,000	5	5 Year
Proposed LFD - Pump 678	DC	LASAN	City	Grey Infrastructure	Centralized	Yes	Yes	No	Funding	\$ -	\$ 3,000,000	\$ 150,000	5	5 Year
Proposed LFD - Pump 692	DC	LASAN	City	Grey Infrastructure	Centralized	Yes	Yes	No	Funding	\$ -	\$ 3,000,000	\$ 150,000	5	5 Year
Proposed LFD - Conceptual Location of Potential LFD in Ballonca Creek Waterhsed	BC	LASAN	City	Grey Infrastructure	Centralized	Yes	Yes	No	Funding	\$ -	\$ 1,500,000	\$ 75,000	5	5 Year
Proposed LFD - Conceptual Location of Potential LFD in Ballonca Creek Waterhsed	BC	LASAN	City	Grey Infrastructure	Centralized	Yes	Yes	No	Funding	\$ -	\$ 1,500,000	\$ 75,000	5	5 Year
Proposed LFD - Victory Blvd & Haskell Ave, Los Angeles, CA	ULAR	LASAN	City	Grey Infrastructure	Centralized	Yes	Yes	No	Funding	\$ -	\$ 1,500,000	\$ 75,000	5	5 Year

Project Name	Watershed	Lead Agency	Project Type	Project Category	Project Size	Known Water Quality Benefit?	Known Water Supply Benefit ?	Known Flood Risk Mitigation Benefit?	Other Considerations	Green Infrastructure Capital Cost	Grey Infrastructure Capital Cost	Annual O&M Cost	Selection Order	SIP Phase
Proposed LFD - Victory Blvd & Peach Ave, Los Angeles, CA	ULAR	LASAN	City	Grey Infrastructure	Centralized	Yes	Yes	No	Funding	\$ -	\$ 1,500,000	\$ 75,000	5	5 Year
Proposed LFD - Victory Blvd & Kester Ave, Los Angeles, CA	ULAR	LASAN	City	Grey Infrastructure	Centralized	Yes	Yes	No	Funding	\$ -	\$ 1,500,000	\$ 75,000	5	5 Year
Proposed LFD - Victory Blvd & Cedros Ave, Los Angeles, CA	ULAR	LASAN	City	Grey Infrastructure	Centralized	Yes	Yes	No	Funding	\$ -	\$ 1,500,000	\$ 75,000	5	5 Year
Proposed LFD - Victory Blvd & Van Nuys Blvd, Los Angeles, CA	ULAR	LASAN	City	Grey Infrastructure	Centralized	Yes	Yes	No	Funding	\$ -	\$ 1,500,000	\$ 75,000	5	5 Year
Proposed LFD - Victory Blvd & Hazeltine Ave, Los Angeles, CA	ULAR	LASAN	City	Grey Infrastructure	Centralized	Yes	Yes	No	Funding	\$ -	\$ 1,500,000	\$ 75,000	5	5 Year
Proposed LFD - Victory Blvd & Tujunga Wash, Los Angeles, CA	ULAR	LASAN	City	Grey Infrastructure	Centralized	Yes	Yes	No	Funding	\$ -	\$ 1,500,000	\$ 75,000	5	5 Year
Proposed LFD - Victory Blvd & Hollywood FWY, Los Angeles, CA	ULAR	LASAN	City	Grey Infrastructure	Centralized	Yes	Yes	No	Funding	\$ -	\$ 1,500,000	\$ 75,000	5	5 Year
Proposed LFD - Victory Blvd & Lankershim Blvd, Los Angeles, CA	ULAR	LASAN	City	Grey Infrastructure	Centralized	Yes	Yes	No	Funding	\$ -	\$ 1,500,000	\$ 75,000	5	5 Year
Proposed LFD - Victory Blvd & Tujunga Ave, Los Angeles, CA	ULAR	LASAN	City	Grey Infrastructure	Centralized	Yes	Yes	No	Funding	\$ -	\$ 1,500,000	\$ 75,000	5	5 Year
Proposed LFD - Victory Blvd & Vineland Ave, Los Angeles, CA	ULAR	LASAN	City	Grey Infrastructure	Centralized	Yes	Yes	No	Funding	\$ -	\$ 1,500,000	\$ 75,000	5	5 Year
Proposed LFD - 2nd st & Santa Fe Ave, Los Angeles, CA	ULAR	LASAN	City	Grey Infrastructure	Centralized	Yes	Yes	No	Funding	\$ -	\$ 1,500,000	\$ 75,000	5	5 Year
Proposed LFD - Missoon rd & Cesar Chavez Ave, Los Angeles, CA	ULAR	LASAN	City	Grey Infrastructure	Centralized	Yes	Yes	No	Funding	\$ -	\$ 1,500,000	\$ 75,000	5	5 Year
Proposed LFD - Palmetto st & Santa Fe Ave, Los Angeles, CA	ULAR	LASAN	City	Grey Infrastructure	Centralized	Yes	Yes	No	Funding	\$ -	\$ 1,500,000	\$ 75,000	5	5 Year
Proposed LFD - Conceptual Location of Potential LFD in Los Angeles River Watershed	ULAR	LASAN	City	Grey Infrastructure	Centralized	Yes	Yes	No	Funding	\$ -	\$ 1,500,000	\$ 75,000	5	5 Year
Proposed LFD - Conceptual Location of Potential LFD in Los Angeles River Watershed	ULAR	LASAN	City	Grey Infrastructure	Centralized	Yes	Yes	No	Funding	\$ -	\$ 1,500,000	\$ 75,000	5	5 Year
Proposed LFD - Conceptual Location of Potential LFD in Los Angeles River Watershed	ULAR	LASAN	City	Grey Infrastructure	Centralized	Yes	Yes	No	Funding	\$ -	\$ 1,500,000	\$ 75,000	5	5 Year
Proposed LFD - Conceptual Location of Potential LFD in Los Angeles River Watershed	ULAR	LASAN	City	Grey Infrastructure	Centralized	Yes	Yes	No	Funding	\$ -	\$ 1,500,000	\$ 75,000	5	5 Year
Proposed LFD - Victory Blvd & Woodyly Ave, Los Angeles, CA	ULAR	LASAN	City	Grey Infrastructure	Centralized	Yes	Yes	No	Funding	\$ -	\$ 1,500,000	\$ 75,000	5	5 Year
Proposed LFD - Victory Blvd & Hayvenhurst Ave, Los Angeles, CA	ULAR	LASAN	City	Grey Infrastructure	Centralized	Yes	Yes	No	Funding	\$ -	\$ 1,500,000	\$ 75,000	5	5 Year
Proposed LFD - Victory Blvd & Louise Ave, Los Angeles, CA	ULAR	LASAN	City	Grey Infrastructure	Centralized	Yes	Yes	No	Funding	\$ -	\$ 1,500,000	\$ 75,000	5	5 Year
Proposed LFD - Victory Blvd & White Oak Ave, Los Angeles, CA	ULAR	LASAN	City	Grey Infrastructure	Centralized	Yes	Yes	No	Funding	\$ -	\$ 1,500,000	\$ 75,000	5	5 Year
Proposed LFD - Victory Blvd & Lindley Ave, Los Angeles, CA	ULAR	LASAN	City	Grey Infrastructure	Centralized	Yes	Yes	No	Funding	\$ -	\$ 1,500,000	\$ 75,000	5	5 Year
Proposed LFD - LA River & Etiwanda Ave, Los Angeles, CA	ULAR	LASAN	City	Grey Infrastructure	Centralized	Yes	Yes	No	Funding	\$ -	\$ 1,500,000	\$ 75,000	5	5 Year
Proposed LFD - Vanowen Street & Reseda Blvd, Los Angeles, CA	ULAR	LASAN	City	Grey Infrastructure	Centralized	Yes	Yes	No	Funding	\$ -	\$ 1,500,000	\$ 75,000	5	5 Year
Proposed LFD - Vanowen Street & Aliso Canyon Wash, Los Angeles, CA	ULAR	LASAN	City	Grey Infrastructure	Centralized	Yes	Yes	No	Funding	\$ -	\$ 1,500,000	\$ 75,000	5	5 Year
Proposed LFD - Vanowen Street & Tampa Ave, Los Angeles, CA	ULAR	LASAN	City	Grey Infrastructure	Centralized	Yes	Yes	No	Funding	\$ -	\$ 1,500,000	\$ 75,000	5	5 Year
Proposed LFD - Vanowen Street & Corbin Ave, Los Angeles, CA	ULAR	LASAN	City	Grey Infrastructure	Centralized	Yes	Yes	No	Funding	\$ -	\$ 1,500,000	\$ 75,000	5	5 Year
Proposed LFD - Vanowen Street & Winnetka Ave, Los Angeles, CA	ULAR	LASAN	City	Grey Infrastructure	Centralized	Yes	Yes	No	Funding	\$ -	\$ 1,500,000	\$ 75,000	5	5 Year
Proposed LFD - Vanowen Street & De Soto Ave, Los Angeles, CA	ULAR	LASAN	City	Grey Infrastructure	Centralized	Yes	Yes	No	Funding	\$ -	\$ 1,500,000	\$ 75,000	5	5 Year
Proposed LFD - Friar Street & Victory Blvd, Los Angeles, CA	ULAR	LASAN	City	Grey Infrastructure	Centralized	Yes	Yes	No	Funding	\$ -	\$ 1,500,000	\$ 75,000	5	5 Year
Proposed LFD - Victory Blvd & Tampa Ave, Los Angeles, CA	ULAR	LASAN	City	Grey Infrastructure	Centralized	Yes	Yes	No	Funding	\$ -	\$ 1,500,000	\$ 75,000	5	5 Year
Proposed LFD - Victory Blvd & Wilbur Ave, Los Angeles, CA	ULAR	LASAN	City	Grey Infrastructure	Centralized	Yes	Yes	No	Funding	\$ -	\$ 1,500,000	\$ 75,000	5	5 Year
Proposed LFD - Victory Blvd & Caballero Creek, Los Angeles, CA	ULAR	LASAN	City	Grey Infrastructure	Centralized	Yes	Yes	No	Funding	\$ -	\$ 1,500,000	\$ 75,000	5	5 Year
Del Rey Lagoon Water Quality Improvement Project	BC	LASAN	City	Green Infrastructure	Centralized	Yes	Yes	Yes	Funding	\$ 1,441,832	\$ -	\$ 72,092	6	5 Year
Dominguez Channel Urban Runoff Project No. 1	DC	LASAN	City	Green Infrastructure	Centralized	Yes	Yes	Yes	Funding	\$ 3,014,000	\$ -	\$ 150,700	6	5 Year
Dominguez Channel Urban Runoff Project No. 2	DC	LASAN	City	Green Infrastructure	Centralized	Yes	Yes	Yes	Funding	\$ 1,411,100	\$ -	\$ 70,555	6	5 Year
Dominguez Channel Urban Runoff Project No. 3	DC	LASAN	City	Green Infrastructure	Centralized	Yes	Yes	Yes	Funding	\$ 775,420	\$ -	\$ 38,771	6	5 Year
LA River Segment B Urban Runoff Project No. 3	ULAR	LASAN	City	Green Infrastructure	Centralized	Yes	Yes	Yes	Funding	\$ 5,343,000	\$ -	\$ 267,150	6	5 Year
Arroyo Seco Urban Runoff Project No. 1	ULAR	LASAN	City	Green Infrastructure	Centralized	Yes	Yes	Yes	Funding	\$ 280,850	\$ -	\$ 14,043	6	5 Year
Arroyo Seco Urban Runoff Project No. 2	ULAR	LASAN	City	Green Infrastructure	Centralized	Yes	Yes	Yes	Funding	\$ 2,457,506	\$ -	\$ 122,875	6	5 Year
Arroyo Seco Urban Runoff Project No. 3	ULAR	LASAN	City	Green Infrastructure	Centralized	Yes	Yes	Yes	Funding	\$ 1,737,112	\$ -	\$ 86,856	6	5 Year
Arroyo Seco Urban Runoff Project No. 4	ULAR	LASAN	City	Green Infrastructure	Centralized	Yes	Yes	Yes	Funding	\$ 4,795,000	\$ -	\$ 239,750	6	5 Year
Arroyo Seco Urban Runoff Project No. 5	ULAR	LASAN	City	Green Infrastructure	Centralized	Yes	Yes	Yes	Funding	\$ 342,500	\$ -	\$ 17,125	6	5 Year
Marina del Rey Tree Wells Project	SMB	LASAN	City	Green Infrastructure	Centralized	Yes	Yes	Yes	Funding	\$ 253,942	\$ -	\$ 12,697	6	5 Year
Oakwood Recreation Center	SMB	LASAN	City	Green Infrastructure	Centralized	Yes	Yes	Yes	Funding	\$ 3,254,019	\$ -	\$ 162,701	6	5 Year
Argo Drain Sub-basin Facility	SMB	LASAN	City	Green Infrastructure	Centralized	Yes	Yes	Yes	Funding	\$ 3,022,664	\$ -	\$ 151,133	6	5 Year
West Adams Green Streets Project 5	BC	LASAN	City	Green - Grey Infrastructure	Distributed	Yes	Yes	Yes	Funding	\$ 1,629,740	\$ -	\$ 97,784	7	5 Year
Hollywood Green Streets Project 7	BC	LASAN	City	Green - Grey Infrastructure	Distributed	Yes	Yes	Yes	Funding	\$ 246,040	\$ -	\$ 14,762	7	5 Year
Wilshire Green Streets Project 5	BC	LASAN	City	Green - Grey Infrastructure	Distributed	Yes	Yes	Yes	Funding	\$ 1,739,340	\$ -	\$ 104,360	7	5 Year
South Los Angeles Green Streets Project 3	BC	LASAN	City	Green - Grey Infrastructure	Distributed	Yes	Yes	Yes	Funding	\$ 478,940	\$ -	\$ 28,736	7	5 Year
Wilshire Green Streets Project 1	BC	LASAN	City	Green - Grey Infrastructure	Distributed	Yes	Yes	Yes	Funding	\$ 1,396,840	\$ -	\$ 83,810	7	5 Year
Southeast Los Angeles Green Streets Project 1	BC	LASAN	City	Green - Grey Infrastructure	Distributed	Yes	Yes	Yes	Funding	\$ 1,232,440	\$ -	\$ 73,946	7	5 Year
Hollywood Green Streets Project 1	BC	LASAN	City	Green - Grey Infrastructure	Distributed	Yes	Yes	Yes	Funding	\$ 4,383,440	\$ -	\$ 263,006	7	5 Year
South Los Angeles Green Streets Project 1	BC	LASAN	City	Green - Grey Infrastructure	Distributed	Yes	Yes	Yes	Funding	\$ 1,725,640	\$ -	\$ 103,538	7	5 Year
West Adams Green Streets Project 1	BC	LASAN	City	Green - Grey Infrastructure	Distributed	Yes	Yes	Yes	Funding	\$ 232,540	\$ -	\$ 13,952	7	5 Year

Project Name	Watershed	Lead Agency	Project Type	Project Category	Project Size	Known Water Quality Benefit?	Known Water Supply Benefit ?	Known Flood Risk Mitigation Benefit?	Other Considerations	Green Infrastructure Capital Cost	Grey Infrastructure Capital Cost	Annual O&M Cost	Selection Order	SIP Phase
West Adams Green Streets Project 2	BC	LASAN	City	Green - Grey Infrastructure	Distributed	Yes	Yes	Yes	Funding	\$ 2,438,040	\$ -	\$ 146,282	7	5 Year
West Adams Green Streets Project 4	BC	LASAN	City	Green - Grey Infrastructure	Distributed	Yes	Yes	Yes	Funding	\$ 5,452,040	\$ -	\$ 327,122	7	5 Year
Wilshire Green Streets Project 3	BC	LASAN	City	Green - Grey Infrastructure	Distributed	Yes	Yes	Yes	Funding	\$ 355,640	\$ -	\$ 21,338	7	5 Year
Harbor Gateway Green Streets Project 1	DC	LASAN	City	Green - Grey Infrastructure	Distributed	Yes	Yes	Yes	Funding	\$ 1,903,740	\$ -	\$ 114,224	7	5 Year
Boyle Heights Green Streets Project 1	ULAR	LASAN	City	Green - Grey Infrastructure	Distributed	Yes	Yes	Yes	Funding	\$ 6,097,149	\$ -	\$ 365,829	7	5 Year
Boyle Heights Green Streets Project 2	ULAR	LASAN	City	Green - Grey Infrastructure	Distributed	Yes	Yes	Yes	Funding	\$ 1,205,039	\$ -	\$ 72,302	7	5 Year
South Los Angeles Green Streets Project 5	ULAR	LASAN	City	Green - Grey Infrastructure	Distributed	Yes	Yes	Yes	Funding	\$ 807,739	\$ -	\$ 48,464	7	5 Year
Southeast Los Angeles Green Streets Project 5	ULAR	LASAN	City	Green - Grey Infrastructure	Distributed	Yes	Yes	Yes	Funding	\$ 725,539	\$ -	\$ 43,532	7	5 Year
Arleta Green Streets Project 1	ULAR	LASAN	City	Green - Grey Infrastructure	Distributed	Yes	Yes	Yes	Funding	\$ 889,939	\$ -	\$ 53,396	7	5 Year
Sheldon St. Priority Greenway	ULAR	LASAN	City	Green - Grey Infrastructure	Distributed	Yes	Yes	Yes	Funding	\$ 2,040,740	\$ -	\$ 122,444	7	5 Year
Encino Green Streets Project 1	ULAR	LASAN	City	Green - Grey Infrastructure	Distributed	Yes	Yes	Yes	Funding	\$ 5,891,000	\$ -	\$ 353,460	7	5 Year
Sherman Oaks Green Streets Project 2	ULAR	LASAN	City	Green - Grey Infrastructure	Distributed	Yes	Yes	Yes	Funding	\$ 159,951	\$ -	\$ 9,597	7	5 Year
Arleta Green Streets Project 2	ULAR	LASAN	City	Green - Grey Infrastructure	Distributed	Yes	Yes	Yes	Funding	\$ 96,901	\$ -	\$ 5,814	7	5 Year
Sun Valley Green Streets Project 1	ULAR	LASAN	City	Green - Grey Infrastructure	Distributed	Yes	Yes	Yes	Funding	\$ 242,401	\$ -	\$ 14,544	7	5 Year
North Hollywood Green Streets Project 1	ULAR	LASAN	City	Green - Grey Infrastructure	Distributed	Yes	Yes	Yes	Funding	\$ 2,081,840	\$ -	\$ 124,910	7	5 Year
Sunland Green Streets Project 3	ULAR	LASAN	City	Green - Grey Infrastructure	Distributed	Yes	Yes	Yes	Funding	\$ 94,476	\$ -	\$ 5,669	7	5 Year
Sunland Green Streets Project 4	ULAR	LASAN	City	Green - Grey Infrastructure	Distributed	Yes	Yes	Yes	Funding	\$ 155,101	\$ -	\$ 9,306	7	5 Year
Chatsworth Green Streets Project 5	ULAR	LASAN	City	Green - Grey Infrastructure	Distributed	Yes	Yes	Yes	Funding	\$ 230,276	\$ -	\$ 13,817	7	5 Year
Northridge Green Streets Project 9	ULAR	LASAN	City	Green - Grey Infrastructure	Distributed	Yes	Yes	Yes	Funding	\$ 4,068,340	\$ -	\$ 244,100	7	5 Year
Canoga Park Green Streets Project 19	ULAR	LASAN	City	Green - Grey Infrastructure	Distributed	Yes	Yes	Yes	Funding	\$ 4,314,940	\$ -	\$ 258,896	7	5 Year
Chatsworth Green Streets Project 8	ULAR	LASAN	City	Green - Grey Infrastructure	Distributed	Yes	Yes	Yes	Funding	\$ 2,232,540	\$ -	\$ 133,952	7	5 Year
Chatsworth Green Streets Project 9	ULAR	LASAN	City	Green - Grey Infrastructure	Distributed	Yes	Yes	Yes	Funding	\$ 3,383,340	\$ -	\$ 203,000	7	5 Year
Granada Hills Green Streets Project 5	ULAR	LASAN	City	Green - Grey Infrastructure	Distributed	Yes	Yes	Yes	Funding	\$ 3,986,741	\$ -	\$ 239,204	7	5 Year
Northridge Green Streets Project 11	ULAR	LASAN	City	Green - Grey Infrastructure	Distributed	Yes	Yes	Yes	Funding	\$ 794,040	\$ -	\$ 47,642	7	5 Year
Burbank Blvd. BMP	ULAR	LABOE/LADWP	City	Green Infrastructure	Distributed	Yes	Yes	Yes	Funding - LADWP	\$ 8,000,000	\$ -	\$ 480,000	7	5 Year
Victory-Vineland Stormwater Capture	ULAR	LADWP	City	Green Infrastructure	Distributed	Yes	Yes	Yes	Open Space and Recreation	\$ 3,000,000	\$ -	\$ 180,000	7	5 Year
Occidental Blvd Green Streets	BC	LASAN	City	Green Infrastructure	Distributed	Yes	Yes	No	Funding	\$ 5,480,000	\$ -	\$ 328,800	8	5 Year
Hollywood Green Streets Project 13	BC	LASAN	City	Green Infrastructure	Distributed	Yes	Yes	No	Funding	\$ 4,780,991	\$ -	\$ 286,859	8	5 Year
Southeast Los Angeles Green Streets Project 2	BC	LASAN	City	Green Infrastructure	Distributed	Yes	Yes	No	Funding	\$ 573,719	\$ -	\$ 34,423	8	5 Year
West Adams - Baldwin Hills - Leimert Green Streets Project 1	BC	LASAN	City	Green Infrastructure	Distributed	Yes	Yes	No	Funding	\$ 1,529,917	\$ -	\$ 91,795	8	5 Year
Westlake Green Streets Project 2	BC	LASAN	City	Green Infrastructure	Distributed	Yes	Yes	No	Funding	\$ 191,239	\$ -	\$ 11,474	8	5 Year
Wilshire Green Streets Project 6	BC	LASAN	City	Green Infrastructure	Distributed	Yes	Yes	No	Funding	\$ 4,016,033	\$ -	\$ 240,962	8	5 Year
Upgrades to Pump Plant 647 and Associated Stormwater Treatment Opportunities	SMB	LASAN	City	Green Infrastructure	Distributed	Yes	Yes	No	Funding	\$ 2,822,200	\$ -	\$ 169,332	8	5 Year
Upgrades to Pump Plant 621 and Associated Stormwater Treatment Opportunities	ULAR	LASAN	City	Green Infrastructure	Distributed	Yes	Yes	No	Funding	\$ 84,776	\$ -	\$ 5,087	8	5 Year
Upgrades to Pump Plant 622 and Associated Stormwater Treatment Opportunities	ULAR	LASAN	City	Green Infrastructure	Distributed	Yes	Yes	No	Funding	\$ 1,780,440	\$ -	\$ 106,826	8	5 Year
Hooper Ave Greenway Alley	ULAR	LASAN	City	Green Infrastructure	Distributed	Yes	Yes	No	Funding	\$ 5,000,000	\$ -	\$ 300,000	8	5 Year
Agnes-Vanowen	ULAR	LASAN/LADWP	City	Green Infrastructure	Distributed	Yes	Yes	No	Funding - LADWP	\$ 3,000,000	\$ -	\$ 150,000	8	5 Year
Branford Street: Laurel Canyon to Pacoima Wash SWCP	ULAR	LASAN/LADWP	City	Green Infrastructure	Distributed	Yes	Yes	No	Funding - LADWP	\$ 5,400,000	\$ -	\$ 324,000	8	5 Year
Glenoaks-Filmore SWCP	ULAR	LASAN/LADWP	City	Green Infrastructure	Distributed	Yes	Yes	No	Funding - LADWP	\$ 3,240,000	\$ -	\$ 194,400	8	5 Year
Glenoaks-Nettleton Median SWCP	ULAR	LASAN/LADWP	City	Green Infrastructure	Distributed	Yes	Yes	No	Funding - LADWP	\$ 1,875,000	\$ -	\$ 112,500	8	5 Year

Project Name	Watershed	Lead Agency	Project Type	Project Category	Project Size	Known Water Quality Benefit?	Known Water Supply Benefit?	Known Flood Risk Mitigation Benefit?	Other Considerations	Green Infrastructure Capital Cost	Grey Infrastructure Capital Cost	Annual O&M Cost	Selection Order	SIP Phase
Lankershim Great Street	ULAR	LASAN/LADWP/LA Mayor's Office	City	Green Infrastructure	Distributed	Yes	Yes	No	Funding - LADWP	\$ 3,780,000	\$ -	\$ 226,800	8	5 Year
Lankershim SWCP - Tuxford to Sherman	ULAR	LASAN/LADWP	City	Green Infrastructure	Distributed	Yes	Yes	No	Funding - LADWP	\$ 9,375,000	\$ -	\$ 562,500	8	5 Year
Saticoy SWCP - Tujunga to Vineland	ULAR	LASAN/LADWP	City	Green Infrastructure	Distributed	Yes	Yes	No	Funding - LADWP	\$ 3,500,000	\$ -	\$ 210,000	8	5 Year
Van Nuys Great Street (Laurel Canyon to San Fernando)	ULAR	LASAN/LADWP/LA Mayor's Office	City	Green Infrastructure	Distributed	Yes	Yes	No	Funding - LADWP	\$ 3,360,000	\$ -	\$ 201,600	8	5 Year
Victory-Goodland Median	ULAR	LASAN/LADWP	City	Green Infrastructure	Distributed	Yes	Yes	No	Funding - LADWP	\$ 4,000,000	\$ -	\$ 240,000	8	5 Year
BC_103249_Block A Green Streets Program	BC	LASAN	City	Green Infrastructure	Distributed	Yes	Yes	No	Funding	\$ 28,912,257	\$ -	\$ 1,734,735	9	5 Year
BC_108449_Block A Green Streets Program	BC	LASAN	City	Green Infrastructure	Distributed	Yes	Yes	No	Funding	\$ 27,523,123	\$ -	\$ 1,651,387	9	5 Year
BC_100449_Block A Green Streets Program	BC	LASAN	City	Green Infrastructure	Distributed	Yes	Yes	No	Funding	\$ 588,496	\$ -	\$ 35,310	9	5 Year
BC_101349_Block A Green Streets Program	BC	LASAN	City	Green Infrastructure	Distributed	Yes	Yes	No	Funding	\$ 1,064,897	\$ -	\$ 63,894	9	5 Year
BC_101849_Block A Green Streets Program	BC	LASAN	City	Green Infrastructure	Distributed	Yes	Yes	No	Funding	\$ 3,923,304	\$ -	\$ 235,398	9	5 Year
BC_102049_Block A Green Streets Program	BC	LASAN	City	Green Infrastructure	Distributed	Yes	Yes	No	Funding	\$ 1,439,798	\$ -	\$ 86,388	9	5 Year
BC_102249_Block A Green Streets Program	BC	LASAN	City	Green Infrastructure	Distributed	Yes	Yes	No	Funding	\$ 2,634,218	\$ -	\$ 158,053	9	5 Year
BC_102649_Block A Green Streets Program	BC	LASAN	City	Green Infrastructure	Distributed	Yes	Yes	No	Funding	\$ 2,914,454	\$ -	\$ 174,867	9	5 Year
BC_103349_Block A Green Streets Program	BC	LASAN	City	Green Infrastructure	Distributed	Yes	Yes	No	Funding	\$ 2,564,159	\$ -	\$ 153,850	9	5 Year
BC_103549_Block A Green Streets Program	BC	LASAN	City	Green Infrastructure	Distributed	Yes	Yes	No	Funding	\$ 14,012	\$ -	\$ 841	9	5 Year
BC_103749_Block A Green Streets Program	BC	LASAN	City	Green Infrastructure	Distributed	Yes	Yes	No	Funding	\$ 3,727,139	\$ -	\$ 223,628	9	5 Year
BC_103849_Block A Green Streets Program	BC	LASAN	City	Green Infrastructure	Distributed	Yes	Yes	No	Funding	\$ 1,373,156	\$ -	\$ 82,389	9	5 Year
BC_103949_Block A Green Streets Program	BC	LASAN	City	Green Infrastructure	Distributed	Yes	Yes	No	Funding	\$ 868,732	\$ -	\$ 52,124	9	5 Year
BC_104049_Block A Green Streets Program	BC	LASAN	City	Green Infrastructure	Distributed	Yes	Yes	No	Funding	\$ 2,227,876	\$ -	\$ 133,673	9	5 Year
BC_104149_Block A Green Streets Program	BC	LASAN	City	Green Infrastructure	Distributed	Yes	Yes	No	Funding	\$ 336,283	\$ -	\$ 20,177	9	5 Year
BC_104349_Block A Green Streets Program	BC	LASAN	City	Green Infrastructure	Distributed	Yes	Yes	No	Funding	\$ 2,220,196	\$ -	\$ 133,212	9	5 Year
BC_105049_Block A Green Streets Program	BC	LASAN	City	Green Infrastructure	Distributed	Yes	Yes	No	Funding	\$ 2,185,841	\$ -	\$ 131,150	9	5 Year
BC_105149_Block A Green Streets Program	BC	LASAN	City	Green Infrastructure	Distributed	Yes	Yes	No	Funding	\$ 4,049,410	\$ -	\$ 242,965	9	5 Year
BC_106349_Block A Green Streets Program	BC	LASAN	City	Green Infrastructure	Distributed	Yes	Yes	No	Funding	\$ 2,844,395	\$ -	\$ 170,664	9	5 Year
BC_106949_Block A Green Streets Program	BC	LASAN	City	Green Infrastructure	Distributed	Yes	Yes	No	Funding	\$ 392,330	\$ -	\$ 23,540	9	5 Year
BC_107349_Block A Green Streets Program	BC	LASAN	City	Green Infrastructure	Distributed	Yes	Yes	No	Funding	\$ 286,191	\$ -	\$ 17,171	9	5 Year
BC_107949_Block A Green Streets Program	BC	LASAN	City	Green Infrastructure	Distributed	Yes	Yes	No	Funding	\$ 14,012	\$ -	\$ 841	9	5 Year
BC_108149_Block A Green Streets Program	BC	LASAN	City	Green Infrastructure	Distributed	Yes	Yes	No	Funding	\$ 1,975,664	\$ -	\$ 118,540	9	5 Year
BC_108249_Block A Green Streets Program	BC	LASAN	City	Green Infrastructure	Distributed	Yes	Yes	No	Funding	\$ 1,345,133	\$ -	\$ 80,708	9	5 Year
BC_108349_Block A Green Streets Program	BC	LASAN	City	Green Infrastructure	Distributed	Yes	Yes	No	Funding	\$ 2,031,711	\$ -	\$ 121,903	9	5 Year
BC_108549_Block A Green Streets Program	BC	LASAN	City	Green Infrastructure	Distributed	Yes	Yes	No	Funding	\$ 1,863,569	\$ -	\$ 111,814	9	5 Year
BC_108649_Block A Green Streets Program	BC	LASAN	City	Green Infrastructure	Distributed	Yes	Yes	No	Funding	\$ 56,047	\$ -	\$ 3,363	9	5 Year
BC_108749_Block A Green Streets Program	BC	LASAN	City	Green Infrastructure	Distributed	Yes	Yes	No	Funding	\$ 1,120,944	\$ -	\$ 67,257	9	5 Year
BC_108949_Block A Green Streets Program	BC	LASAN	City	Green Infrastructure	Distributed	Yes	Yes	No	Funding	\$ 98,083	\$ -	\$ 5,885	9	5 Year
BC_109149_Block A Green Streets Program	BC	LASAN	City	Green Infrastructure	Distributed	Yes	Yes	No	Funding	\$ 3,671,092	\$ -	\$ 220,265	9	5 Year
BC_109249_Block A Green Streets Program	BC	LASAN	City	Green Infrastructure	Distributed	Yes	Yes	No	Funding	\$ 3,895,280	\$ -	\$ 233,717	9	5 Year
BC_109449_Block A Green Streets Program	BC	LASAN	City	Green Infrastructure	Distributed	Yes	Yes	No	Funding	\$ 1,401	\$ -	\$ 84	9	5 Year
BC_109649_Block A Green Streets Program	BC	LASAN	City	Green Infrastructure	Distributed	Yes	Yes	No	Funding	\$ 1,621,394	\$ -	\$ 97,284	9	5 Year
BC_109749_Block A Green Streets Program	BC	LASAN	City	Green Infrastructure	Distributed	Yes	Yes	No	Funding	\$ 1,947,640	\$ -	\$ 116,858	9	5 Year
BC_109849_Block A Green Streets Program	BC	LASAN	City	Green Infrastructure	Distributed	Yes	Yes	No	Funding	\$ 3,096,608	\$ -	\$ 185,796	9	5 Year
BC_110049_Block A Green Streets Program	BC	LASAN	City	Green Infrastructure	Distributed	Yes	Yes	No	Funding	\$ 3,306,785	\$ -	\$ 198,407	9	5 Year
BC_110149_Block A Green Streets Program	BC	LASAN	City	Green Infrastructure	Distributed	Yes	Yes	No	Funding	\$ 2,704,277	\$ -	\$ 162,257	9	5 Year
BC_110749_Block A Green Streets Program	BC	LASAN	City	Green Infrastructure	Distributed	Yes	Yes	No	Funding	\$ 1,289,086	\$ -	\$ 77,345	9	5 Year
BC_110949_Block A Green Streets Program	BC	LASAN	City	Green Infrastructure	Distributed	Yes	Yes	No	Funding	\$ 2,307,981	\$ -	\$ 138,479	9	5 Year
BC_111449_Block A Green Streets Program	BC	LASAN	City	Green Infrastructure	Distributed	Yes	Yes	No	Funding	\$ 2,143,805	\$ -	\$ 128,628	9	5 Year
BC_102849_Block A Green Streets Program	BC	LASAN	City	Green Infrastructure	Distributed	Yes	Yes	No	Funding	\$ 5,142,331	\$ -	\$ 308,540	9	5 Year
BC_102949_Block A Green Streets Program	BC	LASAN	City	Green Infrastructure	Distributed	Yes	Yes	No	Funding	\$ 12,446,111	\$ -	\$ 746,767	9	5 Year
BC_103649_Block A Green Streets Program	BC	LASAN	City	Green Infrastructure	Distributed	Yes	Yes	No	Funding	\$ 11,994,101	\$ -	\$ 719,646	9	5 Year
BC_104949_Block A Green Streets Program	BC	LASAN	City	Green Infrastructure	Distributed	Yes	Yes	No	Funding	\$ 8,407,080	\$ -	\$ 504,425	9	5 Year
BC_106249_Block A Green Streets Program	BC	LASAN	City	Green Infrastructure	Distributed	Yes	Yes	No	Funding	\$ 4,553,835	\$ -	\$ 273,230	9	5 Year
BC_107149_Block A Green Streets Program	BC	LASAN	City	Green Infrastructure	Distributed	Yes	Yes	No	Funding	\$ 6,095,133	\$ -	\$ 365,708	9	5 Year
BC_107449_Block A Green Streets Program	BC	LASAN	City	Green Infrastructure	Distributed	Yes	Yes	No	Funding	\$ 4,890,118	\$ -	\$ 293,407	9	5 Year
BC_107549_Block A Green Streets Program	BC	LASAN	City	Green Infrastructure	Distributed	Yes	Yes	No	Funding	\$ 5,309,225	\$ -	\$ 318,554	9	5 Year
BC_107649_Block A Green Streets Program	BC	LASAN	City	Green Infrastructure	Distributed	Yes	Yes	No	Funding	\$ 11,335,546	\$ -	\$ 680,133	9	5 Year
BC_108849_Block A Green Streets Program	BC	LASAN	City	Green Infrastructure	Distributed	Yes	Yes	No	Funding	\$ 14,756,752	\$ -	\$ 885,405	9	5 Year
BC_109049_Block A Green Streets Program	BC	LASAN	City	Green Infrastructure	Distributed	Yes	Yes	No	Funding	\$ 9,584,071	\$ -	\$ 575,044	9	5 Year
BC_109549_Block A Green Streets Program	BC	LASAN	City	Green Infrastructure	Distributed	Yes	Yes	No	Funding	\$ 8,659,292	\$ -	\$ 519,558	9	5 Year
BC_109949_Block A Green Streets Program	BC	LASAN	City	Green Infrastructure	Distributed	Yes	Yes	No	Funding	\$ 5,730,826	\$ -	\$ 343,850	9	5 Year
BC_110249_Block A Green Streets Program	BC	LASAN	City	Green Infrastructure	Distributed	Yes	Yes	No	Funding	\$ 22,555,126	\$ -	\$ 1,353,308	9	5 Year
BC_110349_Block A Green Streets Program	BC	LASAN	City	Green Infrastructure	Distributed	Yes	Yes	No	Funding	\$ 1,373,434	\$ -	\$ 82,406	9	5 Year
BC_110449_Block A Green Streets Program	BC	LASAN	City	Green Infrastructure	Distributed	Yes	Yes	No	Funding	\$ 7,646,291	\$ -	\$ 458,777	9	5 Year
BC_110549_Block A Green Streets Program	BC	LASAN	City	Green Infrastructure	Distributed	Yes	Yes	No	Funding	\$ 12,134,219	\$ -	\$ 728,053	9	5 Year
BC_110849_Block A Green Streets Program	BC	LASAN	City	Green Infrastructure	Distributed	Yes	Yes	No	Funding	\$ 13,563,422	\$ -	\$ 813,805	9	5 Year
BC_111249_Block A Green Streets Program	BC	LASAN	City	Green Infrastructure	Distributed	Yes	Yes	No	Funding	\$ 5,148,141	\$ -	\$ 308,888	9	5 Year
BC_111349_Block A Green Streets Program	BC	LASAN	City	Green Infrastructure	Distributed	Yes	Yes	No	Funding	\$ 14,226,609	\$ -	\$ 853,597	9	5 Year
SMB_3-04_Block A Green Streets Program	SMB	LASAN	City	Green Infrastructure	Distributed	Yes	Yes	No	Funding	\$ 38,179,789	\$ -	\$ 2,290,787	9	5 Year
SMB_2-01_Block A Green Streets Program	SMB	LASAN	City	Green Infrastructure	Distributed	Yes	Yes	No	Funding	\$ 2,087,758	\$ -	\$ 125,265	9	5 Year

Project Name	Watershed	Lead Agency	Project Type	Project Category	Project Size	Known Water Quality Benefit?	Known Water Supply Benefit ?	Known Flood Risk Mitigation Benefit?	Other Considerations	Green Infrastructure Capital Cost	Grey Infrastructure Capital Cost	Annual O&M Cost	Selection Order	SIP Phase
SMB_2-01_2-02_Block A Green Streets Program	SMB	LASAN	City	Green Infrastructure	Distributed	Yes	Yes	No	Funding	\$ 420,354	\$ -	\$ 25,221	9	5 Year
SMB_2-03_Block A Green Streets Program	SMB	LASAN	City	Green Infrastructure	Distributed	Yes	Yes	No	Funding	\$ 812,684	\$ -	\$ 48,761	9	5 Year
SMB_2-04_2-06_Block A Green Streets Program	SMB	LASAN	City	Green Infrastructure	Distributed	Yes	Yes	No	Funding	\$ 602,507	\$ -	\$ 36,150	9	5 Year
SMB_2-05_Block A Green Streets Program	SMB	LASAN	City	Green Infrastructure	Distributed	Yes	Yes	No	Funding	\$ 2,382,006	\$ -	\$ 142,920	9	5 Year
SMB_2-06_Block A Green Streets Program	SMB	LASAN	City	Green Infrastructure	Distributed	Yes	Yes	No	Funding	\$ 560,472	\$ -	\$ 33,628	9	5 Year
SMB_2-07_3-01_Block A Green Streets Program	SMB	LASAN	City	Green Infrastructure	Distributed	Yes	Yes	No	Funding	\$ 238,201	\$ -	\$ 14,292	9	5 Year
SMB_2-10_Block A Green Streets Program	SMB	LASAN	City	Green Infrastructure	Distributed	Yes	Yes	No	Funding	\$ 1,541,298	\$ -	\$ 92,478	9	5 Year
SMB_2-10_2-11_Block A Green Streets Program	SMB	LASAN	City	Green Infrastructure	Distributed	Yes	Yes	No	Funding	\$ 378,319	\$ -	\$ 22,699	9	5 Year
SMB_2-11_Block A Green Streets Program	SMB	LASAN	City	Green Infrastructure	Distributed	Yes	Yes	No	Funding	\$ 575,576	\$ -	\$ 34,535	9	5 Year
SMB_3-06_Block A Green Streets Program	SMB	LASAN	City	Green Infrastructure	Distributed	Yes	Yes	No	Funding	\$ 3,939,050	\$ -	\$ 236,343	9	5 Year
SMB_2-02_Block A Green Streets Program	SMB	LASAN	City	Green Infrastructure	Distributed	Yes	Yes	No	Funding	\$ 8,477,139	\$ -	\$ 508,628	9	5 Year
SMB_2-04_Block A Green Streets Program	SMB	LASAN	City	Green Infrastructure	Distributed	Yes	Yes	No	Funding	\$ 9,401,918	\$ -	\$ 564,115	9	5 Year
SMB_2-06_2-07_Block A Green Streets Program	SMB	LASAN	City	Green Infrastructure	Distributed	Yes	Yes	No	Funding	\$ 3,616,958	\$ -	\$ 217,017	9	5 Year
Bel Air Green Streets Project 1	BC	LASAN	City	Green - Grey Infrastructure	Distributed	Yes	Yes	Yes	Funding	\$ 5,972,640	\$ -	\$ 358,358	10	5 Year
Bel Air Green Streets Project 2	BC	LASAN	City	Green - Grey Infrastructure	Distributed	Yes	Yes	Yes	Funding	\$ 4,465,640	\$ -	\$ 267,938	10	5 Year
Westlake Green Streets Project 1	BC	LASAN	City	Green - Grey Infrastructure	Distributed	Yes	Yes	Yes	Funding	\$ 424,140	\$ -	\$ 25,448	10	5 Year
Palms Green Streets Project 1	BC	LASAN	City	Green - Grey Infrastructure	Distributed	Yes	Yes	Yes	Funding	\$ 739,240	\$ -	\$ 44,354	10	5 Year
Hollywood Green Streets Project 8	BC	LASAN	City	Green - Grey Infrastructure	Distributed	Yes	Yes	Yes	Funding	\$ 232,340	\$ -	\$ 13,940	10	5 Year
Bel Air Green Streets Project 3	BC	LASAN	City	Green - Grey Infrastructure	Distributed	Yes	Yes	Yes	Funding	\$ 478,940	\$ -	\$ 28,736	10	5 Year
Hollywood Green Streets Project 9	BC	LASAN	City	Green - Grey Infrastructure	Distributed	Yes	Yes	Yes	Funding	\$ 204,940	\$ -	\$ 12,296	10	5 Year
Hollywood Green Streets Project 10	BC	LASAN	City	Green - Grey Infrastructure	Distributed	Yes	Yes	Yes	Funding	\$ 341,939	\$ -	\$ 20,516	10	5 Year
West Adams Green Streets Project 6	BC	LASAN	City	Green - Grey Infrastructure	Distributed	Yes	Yes	Yes	Funding	\$ 287,139	\$ -	\$ 17,228	10	5 Year
Silver Lake Green Streets Project 2	BC	LASAN	City	Green - Grey Infrastructure	Distributed	Yes	Yes	Yes	Funding	\$ 204,939	\$ -	\$ 12,296	10	5 Year
Hollywood Green Streets Project 11	BC	LASAN	City	Green - Grey Infrastructure	Distributed	Yes	Yes	Yes	Funding	\$ 711,839	\$ -	\$ 42,710	10	5 Year
Hollywood Green Streets Project 12	BC	LASAN	City	Green - Grey Infrastructure	Distributed	Yes	Yes	Yes	Funding	\$ 437,839	\$ -	\$ 26,270	10	5 Year
West Adams Green Streets Project 7	BC	LASAN	City	Green - Grey Infrastructure	Distributed	Yes	Yes	Yes	Funding	\$ 300,839	\$ -	\$ 18,050	10	5 Year
Wilshire Green Streets Project 2	BC	LASAN	City	Green - Grey Infrastructure	Distributed	Yes	Yes	Yes	Funding	\$ 698,140	\$ -	\$ 41,888	10	5 Year
Silver Lake Green Streets Project 1	BC	LASAN	City	Green - Grey Infrastructure	Distributed	Yes	Yes	Yes	Funding	\$ 451,540	\$ -	\$ 27,092	10	5 Year
Hollywood Green Streets Project 2	BC	LASAN	City	Green - Grey Infrastructure	Distributed	Yes	Yes	Yes	Funding	\$ 2,944,940	\$ -	\$ 176,696	10	5 Year
West Adams Green Streets Project 3	BC	LASAN	City	Green - Grey Infrastructure	Distributed	Yes	Yes	Yes	Funding	\$ 1,122,840	\$ -	\$ 67,370	10	5 Year
South Los Angeles Green Streets Project 2	BC	LASAN	City	Green - Grey Infrastructure	Distributed	Yes	Yes	Yes	Funding	\$ 958,440	\$ -	\$ 57,506	10	5 Year
Hollywood Green Streets Project 3	BC	LASAN	City	Green - Grey Infrastructure	Distributed	Yes	Yes	Yes	Funding	\$ 246,040	\$ -	\$ 14,762	10	5 Year
Hollywood Green Streets Project 4	BC	LASAN	City	Green - Grey Infrastructure	Distributed	Yes	Yes	Yes	Funding	\$ 862,540	\$ -	\$ 51,752	10	5 Year
Hollywood Green Streets Project 5	BC	LASAN	City	Green - Grey Infrastructure	Distributed	Yes	Yes	Yes	Funding	\$ 328,240	\$ -	\$ 19,694	10	5 Year
Hollywood Green Streets Project 6	BC	LASAN	City	Green - Grey Infrastructure	Distributed	Yes	Yes	Yes	Funding	\$ 218,640	\$ -	\$ 13,118	10	5 Year
Wilmington-Harbor City Green Streets Project 2	DC	LASAN	City	Green - Grey Infrastructure	Distributed	Yes	Yes	Yes	Funding	\$ 29,324,850	\$ -	\$ 1,759,491	10	5 Year
Wilmington-Harbor City Green Streets Project 4	DC	LASAN	City	Green - Grey Infrastructure	Distributed	Yes	Yes	Yes	Funding	\$ 931,040	\$ -	\$ 55,862	10	5 Year
Wilmington-Harbor City Green Streets Project 5	DC	LASAN	City	Green - Grey Infrastructure	Distributed	Yes	Yes	Yes	Funding	\$ 70,226	\$ -	\$ 4,214	10	5 Year
San Pedro Green Streets Project 1	SMB	LASAN	City	Green - Grey Infrastructure	Distributed	Yes	Yes	Yes	Funding	\$ 903,640	\$ -	\$ 54,218	10	5 Year
San Pedro Green Streets Project 2	SMB	LASAN	City	Green - Grey Infrastructure	Distributed	Yes	Yes	Yes	Funding	\$ 2,109,239	\$ -	\$ 126,554	10	5 Year
San Pedro Green Streets Project 3	DC	LASAN	City	Green - Grey Infrastructure	Distributed	Yes	Yes	Yes	Funding	\$ 1,109,140	\$ -	\$ 66,548	10	5 Year

Project Name	Watershed	Lead Agency	Project Type	Project Category	Project Size	Known Water Quality Benefit?	Known Water Supply Benefit ?	Known Flood Risk Mitigation Benefit?	Other Considerations	Green Infrastructure Capital Cost	Grey Infrastructure Capital Cost	Annual O&M Cost	Selection Order	SIP Phase
Wilmington - Harbor City Green Streets Project 12	DC	LASAN	City	Green - Grey Infrastructure	Distributed	Yes	Yes	Yes	Funding	\$ 3,766,939	\$ -	\$ 226,016	10	5 Year
Wilmington - Harbor City Green Streets Project 6	DC	LASAN	City	Green - Grey Infrastructure	Distributed	Yes	Yes	Yes	Funding	\$ 7,137,139	\$ -	\$ 428,228	10	5 Year
Harbor Gateway Green Streets Project 2	DC	LASAN	City	Green - Grey Infrastructure	Distributed	Yes	Yes	Yes	Funding	\$ 1,383,139	\$ -	\$ 82,988	10	5 Year
Wilmington - Harbor City Green Streets Project 7	DC	LASAN	City	Green - Grey Infrastructure	Distributed	Yes	Yes	Yes	Funding	\$ 5,397,239	\$ -	\$ 323,834	10	5 Year
Wilmington - Harbor City Green Streets Project 8	DC	LASAN	City	Green - Grey Infrastructure	Distributed	Yes	Yes	Yes	Funding	\$ 1,739,339	\$ -	\$ 104,360	10	5 Year
Wilmington - Harbor City Green Streets Project 9	DC	LASAN	City	Green - Grey Infrastructure	Distributed	Yes	Yes	Yes	Funding	\$ 3,657,339	\$ -	\$ 219,440	10	5 Year
Wilmington - Harbor City Green Streets Project 10	DC	LASAN	City	Green - Grey Infrastructure	Distributed	Yes	Yes	Yes	Funding	\$ 2,205,139	\$ -	\$ 132,308	10	5 Year
Wilmington - Harbor City Green Streets Project 11	DC	LASAN	City	Green - Grey Infrastructure	Distributed	Yes	Yes	Yes	Funding	\$ 6,411,039	\$ -	\$ 384,662	10	5 Year
Harbor Gateway Green Streets Project 3	DC	LASAN	City	Green - Grey Infrastructure	Distributed	Yes	Yes	Yes	Funding	\$ 3,903,939	\$ -	\$ 234,236	10	5 Year
Wilmington-Harbor City Green Streets Project 1	DC	LASAN	City	Green - Grey Infrastructure	Distributed	Yes	Yes	Yes	Funding	\$ 1,095,439	\$ -	\$ 65,726	10	5 Year
Wilmington - Harbor City Green Streets Project 13	DC	LASAN	City	Green - Grey Infrastructure	Distributed	Yes	Yes	Yes	Funding	\$ 2,205,139	\$ -	\$ 132,308	10	5 Year
San Pedro Green Streets Project 4	SMB	LASAN	City	Green - Grey Infrastructure	Distributed	Yes	Yes	Yes	Funding	\$ 3,068,239	\$ -	\$ 184,094	10	5 Year
Wilmington - Harbor City Green Streets Project 14	DC	LASAN	City	Green - Grey Infrastructure	Distributed	Yes	Yes	Yes	Funding	\$ 8,918,139	\$ -	\$ 535,088	10	5 Year
Wilmington - Harbor City Green Streets Project 15	DC	LASAN	City	Green - Grey Infrastructure	Distributed	Yes	Yes	Yes	Funding	\$ 8,589,339	\$ -	\$ 515,360	10	5 Year
Wilmington - Harbor City Green Streets Project 16	DC	LASAN	City	Green - Grey Infrastructure	Distributed	Yes	Yes	Yes	Funding	\$ 2,451,739	\$ -	\$ 147,104	10	5 Year
San Pedro Green Streets Project 5	SMB	LASAN	City	Green - Grey Infrastructure	Distributed	Yes	Yes	Yes	Funding	\$ 1,068,039	\$ -	\$ 64,082	10	5 Year
Harbor Gateway Green Streets Project 4	DC	LASAN	City	Green - Grey Infrastructure	Distributed	Yes	Yes	Yes	Funding	\$ 273,439	\$ -	\$ 16,406	10	5 Year
San Pedro Green Streets Project 6	SMB	LASAN	City	Green - Grey Infrastructure	Distributed	Yes	Yes	Yes	Funding	\$ 7,219,339	\$ -	\$ 433,160	10	5 Year
San Pedro Green Streets Project 7	DC	LASAN	City	Green - Grey Infrastructure	Distributed	Yes	Yes	Yes	Funding	\$ 1,342,039	\$ -	\$ 80,522	10	5 Year
Wilmington - Harbor City Green Streets Project 17	DC	LASAN	City	Green - Grey Infrastructure	Distributed	Yes	Yes	Yes	Funding	\$ 2,150,339	\$ -	\$ 129,020	10	5 Year
Harbor Gateway Green Streets Project 5	DC	LASAN	City	Green - Grey Infrastructure	Distributed	Yes	Yes	Yes	Funding	\$ 2,944,939	\$ -	\$ 176,696	10	5 Year
San Pedro Green Streets Project 8	SMB	LASAN	City	Green - Grey Infrastructure	Distributed	Yes	Yes	Yes	Funding	\$ 1,629,739	\$ -	\$ 97,784	10	5 Year
San Pedro Green Streets Project 9	DC	LASAN	City	Green - Grey Infrastructure	Distributed	Yes	Yes	Yes	Funding	\$ 2,273,639	\$ -	\$ 136,418	10	5 Year
South Los Angeles Green Streets Project 6	DC	LASAN	City	Green - Grey Infrastructure	Distributed	Yes	Yes	Yes	Funding	\$ 2,355,840	\$ -	\$ 141,350	10	5 Year
Wilmington-Harbor City Green Streets Project 3	DC	LASAN	City	Green - Grey Infrastructure	Distributed	Yes	Yes	Yes	Funding	\$ 8,068,739	\$ -	\$ 484,124	10	5 Year
Venice Green Streets Project 1	SMB	LASAN	City	Green - Grey Infrastructure	Distributed	Yes	Yes	Yes	Funding	\$ 5,369,839	\$ -	\$ 322,190	10	5 Year
Brentwood - Pacific Palisades Green Streets Project 1	SMB	LASAN	City	Green - Grey Infrastructure	Distributed	Yes	Yes	Yes	Funding	\$ 5,000,000	\$ -	\$ 300,000	10	5 Year
Brentwood - Pacific Palisades Green Streets Project 2	SMB	LASAN	City	Green - Grey Infrastructure	Distributed	Yes	Yes	Yes	Funding	\$ 2,712,040	\$ -	\$ 162,722	10	5 Year
Brentwood - Pacific Palisades Green Streets Project 3	SMB	LASAN	City	Green - Grey Infrastructure	Distributed	Yes	Yes	Yes	Funding	\$ 4,583,741	\$ -	\$ 275,024	10	5 Year
Brentwood - Pacific Palisades Green Streets Project 4	SMB	LASAN	City	Green - Grey Infrastructure	Distributed	Yes	Yes	Yes	Funding	\$ 1,040,640	\$ -	\$ 62,438	10	5 Year
Brentwood - Pacific Palisades Green Streets Project 5	SMB	LASAN	City	Green - Grey Infrastructure	Distributed	Yes	Yes	Yes	Funding	\$ 1,396,839	\$ -	\$ 83,810	10	5 Year
Northeast Los Angeles Green Streets Project 4	ULAR	LASAN	City	Green - Grey Infrastructure	Distributed	Yes	Yes	Yes	Funding	\$ 1,026,939	\$ -	\$ 61,616	10	5 Year
Northeast Los Angeles Green Streets Project 6	ULAR	LASAN	City	Green - Grey Infrastructure	Distributed	Yes	Yes	Yes	Funding	\$ 1,040,639	\$ -	\$ 62,438	10	5 Year
Sunland Green Streets Project 1	ULAR	LASAN	City	Green - Grey Infrastructure	Distributed	Yes	Yes	Yes	Funding	\$ 2,520,240	\$ -	\$ 151,214	10	5 Year

Project Name	Watershed	Lead Agency	Project Type	Project Category	Project Size	Known Water Quality Benefit?	Known Water Supply Benefit?	Known Flood Risk Mitigation Benefit?	Other Considerations	Green Infrastructure Capital Cost	Grey Infrastructure Capital Cost	Annual O&M Cost	Selection Order	SIP Phase
Arlita Green Streets Project 4	ULAR	LASAN	City	Green - Grey Infrastructure	Distributed	Yes	Yes	Yes	Funding	\$ 2,259,940	\$ -	\$ 135,596	10	5 Year
Sunland Green Streets Project 2	ULAR	LASAN	City	Green - Grey Infrastructure	Distributed	Yes	Yes	Yes	Funding	\$ 2,575,040	\$ -	\$ 154,502	10	5 Year
Sunland Green Streets Project 5	ULAR	LASAN	City	Green - Grey Infrastructure	Distributed	Yes	Yes	Yes	Funding	\$ 3,839,644	\$ -	\$ 230,379	10	5 Year
Sunland Green Streets Project 7	ULAR	LASAN	City	Green - Grey Infrastructure	Distributed	Yes	Yes	Yes	Funding	\$ 60,526	\$ -	\$ 3,632	10	5 Year
Sunland Green Streets Project 8	ULAR	LASAN	City	Green - Grey Infrastructure	Distributed	Yes	Yes	Yes	Funding	\$ 77,501	\$ -	\$ 4,650	10	5 Year
Chatsworth Green Streets Project 6	ULAR	LASAN	City	Green - Grey Infrastructure	Distributed	Yes	Yes	Yes	Funding	\$ 2,191,440	\$ -	\$ 131,486	10	5 Year
Northridge Green Streets Project 10	ULAR	LASAN	City	Green - Grey Infrastructure	Distributed	Yes	Yes	Yes	Funding	\$ 725,540	\$ -	\$ 43,532	10	5 Year
Burwood & Figueroa SW Capture Greenway	ULAR	LASAN	City	Green - Grey Infrastructure	Distributed	Yes	Yes	Yes	Funding	\$ 5,000,000	\$ -	\$ 300,000	10	5 Year
Bel Air - Beverly Crest Green Streets Project 1	BC	LASAN	City	Green Infrastructure	Distributed	Yes	Yes	No	Funding	\$ 191,239	\$ -	\$ 11,474	11	5 Year
Palms - Mar Vista - Del Rey Green Streets Project 1	BC	LASAN	City	Green Infrastructure	Distributed	Yes	Yes	No	Funding	\$ 1,147,438	\$ -	\$ 68,846	11	5 Year
Silver Lake - Echo Park - Elysian Valley Green Streets Project 1	BC	LASAN	City	Green Infrastructure	Distributed	Yes	Yes	No	Funding	\$ 191,239	\$ -	\$ 11,474	11	5 Year
South Los Angeles Green Streets Project 4	BC	LASAN	City	Green Infrastructure	Distributed	Yes	Yes	No	Funding	\$ 764,958	\$ -	\$ 45,897	11	5 Year
West Los Angeles Green Streets Project 14	BC	LASAN	City	Green Infrastructure	Distributed	Yes	Yes	No	Funding	\$ 3,442,314	\$ -	\$ 206,539	11	5 Year
Westchester - Playa del Rey Green Streets Project 1	BC	LASAN	City	Green Infrastructure	Distributed	Yes	Yes	No	Funding	\$ 1,912,396	\$ -	\$ 114,744	11	5 Year
Westwood Green Streets Project 1	BC	LASAN	City	Green Infrastructure	Distributed	Yes	Yes	No	Funding	\$ 382,479	\$ -	\$ 22,949	11	5 Year
Green Streets Distributed within BC above Sawtelle Blvd	BC	LASAN	City	Green Infrastructure	Distributed	Yes	Yes	No	Funding	\$ 468,073,972	\$ -	\$ 28,084,438	11	5 Year
Green Streets Distributed within Centinela Creek	BC	LASAN	City	Green Infrastructure	Distributed	Yes	Yes	No	Funding	\$ 36,018,124	\$ -	\$ 2,161,087	11	5 Year
Green Streets Distributed within Sepulveda Channel	BC	LASAN	City	Green Infrastructure	Distributed	Yes	Yes	No	Funding	\$ 109,582,415	\$ -	\$ 6,574,945	11	5 Year
Westwood Neighborhood Greenway Project	BC	LASAN	City	Green Infrastructure	Distributed	Yes	Yes	No	Funding	\$ 3,104,420	\$ -	\$ 186,265	11	5 Year
Manchester Neighborhood Greenway Project	BC	LASAN	City	Green Infrastructure	Distributed	Yes	Yes	No	Funding	\$ 780,316	\$ -	\$ 46,819	11	5 Year
San Pedro and 3rd SW Capture Greenway	DC	LASAN	City	Green Infrastructure	Distributed	Yes	Yes	No	Funding	\$ 10,000,000	\$ -	\$ 600,000	11	5 Year
4th St & Santa Fe Priority Greenway + Sustainable Little Tokyo	ULAR	LASAN	City	Green Infrastructure	Distributed	Yes	Yes	No	Funding	\$ 17,125,000	\$ -	\$ 1,027,500	11	5 Year
Marina del Rey Green Streets Project 4	SMB	LASAN	City	Green Infrastructure	Distributed	Yes	Yes	No	Funding	\$ 18,678,807	\$ -	\$ 1,120,728	11	5 Year
Marina del Rey Green Streets Project 5	SMB	LASAN	City	Green Infrastructure	Distributed	Yes	Yes	No	Funding	\$ 98,944,616	\$ -	\$ 5,936,677	11	5 Year
Venice Blvd. Neighborhood Green Streets	SMB	LASAN	City	Green Infrastructure	Distributed	Yes	Yes	No	Funding	\$ 81,070,737	\$ -	\$ 4,864,244	11	5 Year
Marina del Rey Green Streets Project 1	SMB	LASAN	City	Green Infrastructure	Distributed	Yes	Yes	No	Funding	\$ 1,666,097	\$ -	\$ 99,966	11	5 Year
Marina del Rey Green Streets Project 2	SMB	LASAN	City	Green Infrastructure	Distributed	Yes	Yes	No	Funding	\$ 3,361,567	\$ -	\$ 201,694	11	5 Year
Marina del Rey Green Streets Project 3	SMB	LASAN	City	Green Infrastructure	Distributed	Yes	Yes	No	Funding	\$ 15,944,378	\$ -	\$ 956,663	11	5 Year
Oakwood Ave Green Alley	SMB	LASAN	City	Green Infrastructure	Distributed	Yes	Yes	No	Funding	\$ 42,196,000	\$ -	\$ 2,531,760	11	5 Year
Brentwood - Pacific Palisades Green Streets Project 6	SMB	LASAN	City	Green Infrastructure	Distributed	Yes	Yes	No	Funding	\$ 533,740	\$ -	\$ 32,024	11	5 Year
Brentwood - Pacific Palisades Green Streets Project 7	SMB	LASAN	City	Green Infrastructure	Distributed	Yes	Yes	No	Funding	\$ 3,824,793	\$ -	\$ 229,488	11	5 Year
Los Angeles International Airport Green Streets Project 1	SMB	LASAN	City	Green Infrastructure	Distributed	Yes	Yes	No	Funding	\$ 4,780,991	\$ -	\$ 286,859	11	5 Year
Westchester - Playa del Rey Green Streets Project 2	SMB	LASAN	City	Green Infrastructure	Distributed	Yes	Yes	No	Funding	\$ 33,851	\$ -	\$ 2,031	11	5 Year
Palms - Mar Vista - Del Rey Green Streets Project 2	SMB	LASAN	City	Green Infrastructure	Distributed	Yes	Yes	No	Funding	\$ 67,702	\$ -	\$ 4,062	11	5 Year
Green Streets Distributed within SMB	SMB	LASAN	City	Green Infrastructure	Distributed	Yes	Yes	No	Funding	\$ 67,702	\$ -	\$ 4,062	11	5 Year
San Fernando Rd from Elm St to Eagle Rock Blvd	ULAR	LASAN	City	Green Infrastructure	Distributed	Yes	Yes	No	Funding	\$ 56,042,590	\$ -	\$ 3,362,555	11	5 Year
Tuxford Pumping Plant No. 614 Climate Change Impact Retrofit	SMB	LASAN	City	Grey Infrastructure	Centralized	Yes	No	Yes	Climate Change	\$ -	\$ 1,110,000	\$ 55,500	12	5 Year
Westside Park Pumping Plant No. 740 Climate Change Impact Retrofit	BC	LASAN	City	Grey Infrastructure	Centralized	Yes	No	Yes	Climate Change	\$ -	\$ 580,000	\$ 29,000	12	5 Year
Los Angeles Zoo Pumping Plant Climate Change Impact Retrofit	ULAR	LASAN	City	Grey Infrastructure	Centralized	Yes	No	Yes	Climate Change	\$ -	\$ 7,250,000	\$ 362,500	12	5 Year
Santa Monica Pumping Plant No.733 Climate Change Impact Retrofit	SMB	LASAN	City	Grey Infrastructure	Centralized	Yes	No	Yes	Climate Change	\$ -	\$ 5,210,000	\$ 260,500	12	5 Year
Temescal Pumping Plant 734	SMB	LASAN	City	Grey Infrastructure	Centralized	Yes	No	Yes	Climate Change	\$ -	\$ 2,470,000	\$ 123,500	12	5 Year
Southerland Pumping Plant No. 692 Climate Change Impact Retrofit	BC	LASAN	City	Grey Infrastructure	Centralized	Yes	No	Yes	Climate Change	\$ -	\$ 15,750,000	\$ 787,500	12	5 Year
Kinney Circle Pumping Plant 647 Climate Change Impact Retrofit	SMB	LASAN	City	Grey Infrastructure	Centralized	Yes	No	Yes	Climate Change	\$ -	\$ 1,910,000	\$ 95,500	12	5 Year
DC Dominguez Channel Estuary Block B Green Streets Program	DC	LASAN	City	Green Infrastructure	Distributed	Yes	Yes	No		\$ 14,700,107	\$ -	\$ 882,006	13	10 Year
DC Dominguez Channel Block B Green Streets Program	DC	LASAN	City	Green Infrastructure	Distributed	Yes	Yes	No		\$ 7,616,561	\$ -	\$ 456,994	13	10 Year
ULAR_604349_Block A Green Streets Program	ULAR	LASAN	City	Green Infrastructure	Distributed	Yes	Yes	No		\$ 11,025,519	\$ -	\$ 661,531	13	10 Year
ULAR_638449_Block A Green Streets Program	ULAR	LASAN	City	Green Infrastructure	Distributed	Yes	Yes	No		\$ 13,720,450	\$ -	\$ 823,227	13	10 Year
ULAR_664949_Block A Green Streets Program	ULAR	LASAN	City	Green Infrastructure	Distributed	Yes	Yes	No		\$ 16,758,113	\$ -	\$ 1,005,487	13	10 Year
ULAR_692849_Block A Green Streets Program	ULAR	LASAN	City	Green Infrastructure	Distributed	Yes	Yes	No		\$ 16,740,462	\$ -	\$ 1,004,428	13	10 Year
ULAR_603649_Block A Green Streets Program	ULAR	LASAN	City	Green Infrastructure	Distributed	Yes	Yes	No		\$ 1,120,944	\$ -	\$ 67,257	13	10 Year
ULAR_603949_Block A Green Streets Program	ULAR	LASAN	City	Green Infrastructure	Distributed	Yes	Yes	No		\$ 63,053	\$ -	\$ 3,783	13	10 Year
ULAR_604149_Block A Green Streets Program	ULAR	LASAN	City	Green Infrastructure	Distributed	Yes	Yes	No		\$ 1,275,074	\$ -	\$ 76,504	13	10 Year
ULAR_604249_Block A Green Streets Program	ULAR	LASAN	City	Green Infrastructure	Distributed	Yes	Yes	No		\$ 581,490	\$ -	\$ 34,889	13	10 Year
ULAR_604449_Block A Green Streets Program	ULAR	LASAN	City	Green Infrastructure	Distributed	Yes	Yes	No		\$ 1,366,151	\$ -	\$ 81,969	13	10 Year
ULAR_604949_Block A Green Streets Program	ULAR	LASAN	City	Green Infrastructure	Distributed	Yes	Yes	No		\$ 1,078,909	\$ -	\$ 64,735	13	10 Year
ULAR_605849_Block A Green Streets Program	ULAR	LASAN	City	Green Infrastructure	Distributed	Yes	Yes	No		\$ 2,017,699	\$ -	\$ 121,062	13	10 Year
ULAR_606349_Block A Green Streets Program	ULAR	LASAN	City	Green Infrastructure	Distributed	Yes	Yes	No		\$ 1,106,932	\$ -	\$ 66,416	13	10 Year
ULAR_606449_Block A Green Streets Program	ULAR	LASAN	City	Green Infrastructure	Distributed	Yes	Yes	No		\$ 1,485,251	\$ -	\$ 89,115	13	10 Year
ULAR_635849_Block A Green Streets Program	ULAR	LASAN	City	Green Infrastructure	Distributed	Yes	Yes	No		\$ 14,012	\$ -	\$ 841	13	10 Year
ULAR_635949_Block A Green Streets Program	ULAR	LASAN	City	Green Infrastructure	Distributed	Yes	Yes	No		\$ 455,384	\$ -	\$ 27,323	13	10 Year
ULAR_636849_Block A Green Streets Program	ULAR	LASAN	City	Green Infrastructure	Distributed	Yes	Yes	No		\$ 14,012	\$ -	\$ 841	13	10 Year

Project Name	Watershed	Lead Agency	Project Type	Project Category	Project Size	Known Water Quality Benefit?	Known Water Supply Benefit?	Known Flood Risk Mitigation Benefit?	Other Considerations	Green Infrastructure Capital Cost	Grey Infrastructure Capital Cost	Annual O&M Cost	Selection Order	SIP Phase
ULAR_637049_Block A Green Streets Program	ULAR	LASAN	City	Green Infrastructure	Distributed	Yes	Yes	No		\$ 7,006	\$ -	\$ 420	13	10 Year
ULAR_638249_Block A Green Streets Program	ULAR	LASAN	City	Green Infrastructure	Distributed	Yes	Yes	No		\$ 14,012	\$ -	\$ 841	13	10 Year
ULAR_639449_Block A Green Streets Program	ULAR	LASAN	City	Green Infrastructure	Distributed	Yes	Yes	No		\$ 1,015,856	\$ -	\$ 60,951	13	10 Year
ULAR_639549_Block A Green Streets Program	ULAR	LASAN	City	Green Infrastructure	Distributed	Yes	Yes	No		\$ 1,127,950	\$ -	\$ 67,677	13	10 Year
ULAR_639749_Block A Green Streets Program	ULAR	LASAN	City	Green Infrastructure	Distributed	Yes	Yes	No		\$ 686,578	\$ -	\$ 41,195	13	10 Year
ULAR_639949_Block A Green Streets Program	ULAR	LASAN	City	Green Infrastructure	Distributed	Yes	Yes	No		\$ 84,071	\$ -	\$ 5,044	13	10 Year
ULAR_640049_Block A Green Streets Program	ULAR	LASAN	City	Green Infrastructure	Distributed	Yes	Yes	No		\$ 105,089	\$ -	\$ 6,305	13	10 Year
ULAR_640749_Block A Green Streets Program	ULAR	LASAN	City	Green Infrastructure	Distributed	Yes	Yes	No		\$ 2,024,705	\$ -	\$ 121,482	13	10 Year
ULAR_640849_Block A Green Streets Program	ULAR	LASAN	City	Green Infrastructure	Distributed	Yes	Yes	No		\$ 1,583,157	\$ -	\$ 94,989	13	10 Year
ULAR_640949_Block A Green Streets Program	ULAR	LASAN	City	Green Infrastructure	Distributed	Yes	Yes	No		\$ 301,254	\$ -	\$ 18,075	13	10 Year
ULAR_641049_Block A Green Streets Program	ULAR	LASAN	City	Green Infrastructure	Distributed	Yes	Yes	No		\$ 1,141,962	\$ -	\$ 68,518	13	10 Year
ULAR_641149_Block A Green Streets Program	ULAR	LASAN	City	Green Infrastructure	Distributed	Yes	Yes	No		\$ 483,407	\$ -	\$ 29,004	13	10 Year
ULAR_647649_Block A Green Streets Program	ULAR	LASAN	City	Green Infrastructure	Distributed	Yes	Yes	No		\$ 742,625	\$ -	\$ 44,558	13	10 Year
ULAR_649149_Block A Green Streets Program	ULAR	LASAN	City	Green Infrastructure	Distributed	Yes	Yes	No		\$ 77,065	\$ -	\$ 4,624	13	10 Year
ULAR_649449_Block A Green Streets Program	ULAR	LASAN	City	Green Infrastructure	Distributed	Yes	Yes	No		\$ 133,112	\$ -	\$ 7,987	13	10 Year
ULAR_649549_Block A Green Streets Program	ULAR	LASAN	City	Green Infrastructure	Distributed	Yes	Yes	No		\$ 1,183,997	\$ -	\$ 71,040	13	10 Year
ULAR_649649_Block A Green Streets Program	ULAR	LASAN	City	Green Infrastructure	Distributed	Yes	Yes	No		\$ 595,502	\$ -	\$ 35,730	13	10 Year
ULAR_651249_Block A Green Streets Program	ULAR	LASAN	City	Green Infrastructure	Distributed	Yes	Yes	No		\$ 182,153	\$ -	\$ 10,929	13	10 Year
ULAR_657149_Block A Green Streets Program	ULAR	LASAN	City	Green Infrastructure	Distributed	Yes	Yes	No		\$ 301,254	\$ -	\$ 18,075	13	10 Year
ULAR_660349_Block A Green Streets Program	ULAR	LASAN	City	Green Infrastructure	Distributed	Yes	Yes	No		\$ 791,667	\$ -	\$ 47,500	13	10 Year
ULAR_661049_Block A Green Streets Program	ULAR	LASAN	City	Green Infrastructure	Distributed	Yes	Yes	No		\$ 28,024	\$ -	\$ 1,681	13	10 Year
ULAR_661249_Block A Green Streets Program	ULAR	LASAN	City	Green Infrastructure	Distributed	Yes	Yes	No		\$ 777,655	\$ -	\$ 46,659	13	10 Year
ULAR_661749_Block A Green Streets Program	ULAR	LASAN	City	Green Infrastructure	Distributed	Yes	Yes	No		\$ 294,248	\$ -	\$ 17,655	13	10 Year
ULAR_661849_Block A Green Streets Program	ULAR	LASAN	City	Green Infrastructure	Distributed	Yes	Yes	No		\$ 889,749	\$ -	\$ 53,385	13	10 Year
ULAR_662249_Block A Green Streets Program	ULAR	LASAN	City	Green Infrastructure	Distributed	Yes	Yes	No		\$ 266,224	\$ -	\$ 15,973	13	10 Year
ULAR_662949_Block A Green Streets Program	ULAR	LASAN	City	Green Infrastructure	Distributed	Yes	Yes	No		\$ 1,169,985	\$ -	\$ 70,199	13	10 Year
ULAR_663549_Block A Green Streets Program	ULAR	LASAN	City	Green Infrastructure	Distributed	Yes	Yes	No		\$ 28,024	\$ -	\$ 1,681	13	10 Year
ULAR_663649_Block A Green Streets Program	ULAR	LASAN	City	Green Infrastructure	Distributed	Yes	Yes	No		\$ 217,183	\$ -	\$ 13,031	13	10 Year
ULAR_663749_Block A Green Streets Program	ULAR	LASAN	City	Green Infrastructure	Distributed	Yes	Yes	No		\$ 308,260	\$ -	\$ 18,496	13	10 Year
ULAR_663849_Block A Green Streets Program	ULAR	LASAN	City	Green Infrastructure	Distributed	Yes	Yes	No		\$ 7,006	\$ -	\$ 420	13	10 Year
ULAR_664649_Block A Green Streets Program	ULAR	LASAN	City	Green Infrastructure	Distributed	Yes	Yes	No		\$ 791,667	\$ -	\$ 47,500	13	10 Year
ULAR_664749_Block A Green Streets Program	ULAR	LASAN	City	Green Infrastructure	Distributed	Yes	Yes	No		\$ 1,303,097	\$ -	\$ 78,186	13	10 Year
ULAR_665349_Block A Green Streets Program	ULAR	LASAN	City	Green Infrastructure	Distributed	Yes	Yes	No		\$ 623,525	\$ -	\$ 37,412	13	10 Year
ULAR_665549_Block A Green Streets Program	ULAR	LASAN	City	Green Infrastructure	Distributed	Yes	Yes	No		\$ 560,472	\$ -	\$ 33,628	13	10 Year
ULAR_665749_Block A Green Streets Program	ULAR	LASAN	City	Green Infrastructure	Distributed	Yes	Yes	No		\$ 49,041	\$ -	\$ 2,942	13	10 Year
ULAR_665949_Block A Green Streets Program	ULAR	LASAN	City	Green Infrastructure	Distributed	Yes	Yes	No		\$ 987,832	\$ -	\$ 59,270	13	10 Year
ULAR_666149_Block A Green Streets Program	ULAR	LASAN	City	Green Infrastructure	Distributed	Yes	Yes	No		\$ 1,485,251	\$ -	\$ 89,115	13	10 Year
ULAR_666249_Block A Green Streets Program	ULAR	LASAN	City	Green Infrastructure	Distributed	Yes	Yes	No		\$ 1,726,189	\$ -	\$ 103,571	13	10 Year
ULAR_666349_Block A Green Streets Program	ULAR	LASAN	City	Green Infrastructure	Distributed	Yes	Yes	No		\$ 546,460	\$ -	\$ 32,788	13	10 Year
ULAR_666449_Block A Green Streets Program	ULAR	LASAN	City	Green Infrastructure	Distributed	Yes	Yes	No		\$ 326,575	\$ -	\$ 19,595	13	10 Year
ULAR_666549_Block A Green Streets Program	ULAR	LASAN	City	Green Infrastructure	Distributed	Yes	Yes	No		\$ 357,301	\$ -	\$ 21,438	13	10 Year
ULAR_667849_Block A Green Streets Program	ULAR	LASAN	City	Green Infrastructure	Distributed	Yes	Yes	No		\$ 7,006	\$ -	\$ 420	13	10 Year
ULAR_667949_Block A Green Streets Program	ULAR	LASAN	City	Green Infrastructure	Distributed	Yes	Yes	No		\$ 126,106	\$ -	\$ 7,566	13	10 Year
ULAR_668449_Block A Green Streets Program	ULAR	LASAN	City	Green Infrastructure	Distributed	Yes	Yes	No		\$ 1,094,735	\$ -	\$ 65,684	13	10 Year
ULAR_669349_Block A Green Streets Program	ULAR	LASAN	City	Green Infrastructure	Distributed	Yes	Yes	No		\$ 1,205,015	\$ -	\$ 72,301	13	10 Year
ULAR_669749_Block A Green Streets Program	ULAR	LASAN	City	Green Infrastructure	Distributed	Yes	Yes	No		\$ 56,047	\$ -	\$ 3,363	13	10 Year
ULAR_672849_Block A Green Streets Program	ULAR	LASAN	City	Green Infrastructure	Distributed	Yes	Yes	No		\$ 7,006	\$ -	\$ 420	13	10 Year
ULAR_673949_Block A Green Streets Program	ULAR	LASAN	City	Green Infrastructure	Distributed	Yes	Yes	No		\$ 14,012	\$ -	\$ 841	13	10 Year
ULAR_682949_Block A Green Streets Program	ULAR	LASAN	City	Green Infrastructure	Distributed	Yes	Yes	No		\$ 420,354	\$ -	\$ 25,221	13	10 Year
ULAR_683049_Block A Green Streets Program	ULAR	LASAN	City	Green Infrastructure	Distributed	Yes	Yes	No		\$ 161,136	\$ -	\$ 9,668	13	10 Year
ULAR_683149_Block A Green Streets Program	ULAR	LASAN	City	Green Infrastructure	Distributed	Yes	Yes	No		\$ 945,797	\$ -	\$ 56,748	13	10 Year
ULAR_683649_Block A Green Streets Program	ULAR	LASAN	City	Green Infrastructure	Distributed	Yes	Yes	No		\$ 1,015,856	\$ -	\$ 60,951	13	10 Year
ULAR_685349_Block A Green Streets Program	ULAR	LASAN	City	Green Infrastructure	Distributed	Yes	Yes	No		\$ 427,360	\$ -	\$ 25,642	13	10 Year
ULAR_686049_Block A Green Streets Program	ULAR	LASAN	City	Green Infrastructure	Distributed	Yes	Yes	No		\$ 7,006	\$ -	\$ 420	13	10 Year
ULAR_686249_Block A Green Streets Program	ULAR	LASAN	City	Green Infrastructure	Distributed	Yes	Yes	No		\$ 896,755	\$ -	\$ 53,805	13	10 Year
ULAR_686449_Block A Green Streets Program	ULAR	LASAN	City	Green Infrastructure	Distributed	Yes	Yes	No		\$ 91,077	\$ -	\$ 5,465	13	10 Year
ULAR_686649_Block A Green Streets Program	ULAR	LASAN	City	Green Infrastructure	Distributed	Yes	Yes	No		\$ 259,218	\$ -	\$ 15,553	13	10 Year
ULAR_686849_Block A Green Streets Program	ULAR	LASAN	City	Green Infrastructure	Distributed	Yes	Yes	No		\$ 1,092,920	\$ -	\$ 65,575	13	10 Year
ULAR_687249_Block A Green Streets Program	ULAR	LASAN	City	Green Infrastructure	Distributed	Yes	Yes	No		\$ 2,024,705	\$ -	\$ 121,482	13	10 Year
ULAR_687349_Block A Green Streets Program	ULAR	LASAN	City	Green Infrastructure	Distributed	Yes	Yes	No		\$ 105,089	\$ -	\$ 6,305	13	10 Year
ULAR_687449_Block A Green Streets Program	ULAR	LASAN	City	Green Infrastructure	Distributed	Yes	Yes	No		\$ 126,106	\$ -	\$ 7,566	13	10 Year
ULAR_687549_Block A Green Streets Program	ULAR	LASAN	City	Green Infrastructure	Distributed	Yes	Yes	No		\$ 1,996,682	\$ -	\$ 119,801	13	10 Year
ULAR_687849_Block A Green Streets Program	ULAR	LASAN	City	Green Infrastructure	Distributed	Yes	Yes	No		\$ 385,325	\$ -	\$ 23,119	13	10 Year
ULAR_688049_Block A Green Streets Program	ULAR	LASAN	City	Green Infrastructure	Distributed	Yes	Yes	No		\$ 7,006	\$ -	\$ 420	13	10 Year
ULAR_688549_Block A Green Streets Program	ULAR	LASAN	City	Green Infrastructure	Distributed	Yes	Yes	No		\$ 1,506,269	\$ -	\$ 90,376	13	10 Year
ULAR_688749_Block A Green Streets Program	ULAR	LASAN	City	Green Infrastructure	Distributed	Yes	Yes	No		\$ 889,749	\$ -	\$ 53,385	13	10 Year
ULAR_688849_Block A Green Streets Program	ULAR	LASAN	City	Green Infrastructure	Distributed	Yes	Yes	No		\$ 1,113,938	\$ -	\$ 66,836	13	10 Year
ULAR_688949_Block A Green Streets Program	ULAR	LASAN	City	Green Infrastructure	Distributed	Yes	Yes	No		\$ 1,324,115	\$ -	\$ 79,447	13	10 Year
ULAR_689349_Block A Green Streets Program	ULAR	LASAN	City	Green Infrastructure	Distributed	Yes	Yes	No		\$ 98,083	\$ -	\$ 5,885	13	10 Year

Project Name	Watershed	Lead Agency	Project Type	Project Category	Project Size	Known Water Quality Benefit?	Known Water Supply Benefit?	Known Flood Risk Mitigation Benefit?	Other Considerations	Green Infrastructure Capital Cost	Grey Infrastructure Capital Cost	Annual O&M Cost	Selection Order	SIP Phase
ULAR_690249_Block A Green Streets Program	ULAR	LASAN	City	Green Infrastructure	Distributed	Yes	Yes	No		\$ 763,643	\$ -	\$ 45,819	13	10 Year
ULAR_691149_Block A Green Streets Program	ULAR	LASAN	City	Green Infrastructure	Distributed	Yes	Yes	No		\$ 126,106	\$ -	\$ 7,566	13	10 Year
ULAR_691249_Block A Green Streets Program	ULAR	LASAN	City	Green Infrastructure	Distributed	Yes	Yes	No		\$ 1,268,068	\$ -	\$ 76,084	13	10 Year
ULAR_691349_Block A Green Streets Program	ULAR	LASAN	City	Green Infrastructure	Distributed	Yes	Yes	No		\$ 42,035	\$ -	\$ 2,522	13	10 Year
ULAR_691549_Block A Green Streets Program	ULAR	LASAN	City	Green Infrastructure	Distributed	Yes	Yes	No		\$ 399,336	\$ -	\$ 23,960	13	10 Year
ULAR_691649_Block A Green Streets Program	ULAR	LASAN	City	Green Infrastructure	Distributed	Yes	Yes	No		\$ 2,101,770	\$ -	\$ 126,106	13	10 Year
ULAR_691849_Block A Green Streets Program	ULAR	LASAN	City	Green Infrastructure	Distributed	Yes	Yes	No		\$ 70,059	\$ -	\$ 4,204	13	10 Year
ULAR_692149_Block A Green Streets Program	ULAR	LASAN	City	Green Infrastructure	Distributed	Yes	Yes	No		\$ 7,006	\$ -	\$ 420	13	10 Year
ULAR_692249_Block A Green Streets Program	ULAR	LASAN	City	Green Infrastructure	Distributed	Yes	Yes	No		\$ 798,673	\$ -	\$ 47,920	13	10 Year
ULAR_692449_Block A Green Streets Program	ULAR	LASAN	City	Green Infrastructure	Distributed	Yes	Yes	No		\$ 1,401,180	\$ -	\$ 84,071	13	10 Year
ULAR_693449_Block A Green Streets Program	ULAR	LASAN	City	Green Infrastructure	Distributed	Yes	Yes	No		\$ 378,319	\$ -	\$ 22,699	13	10 Year
ULAR_694149_Block A Green Streets Program	ULAR	LASAN	City	Green Infrastructure	Distributed	Yes	Yes	No		\$ 7,006	\$ -	\$ 420	13	10 Year
ULAR_694249_Block A Green Streets Program	ULAR	LASAN	City	Green Infrastructure	Distributed	Yes	Yes	No		\$ 721,608	\$ -	\$ 43,296	13	10 Year
ULAR_694349_Block A Green Streets Program	ULAR	LASAN	City	Green Infrastructure	Distributed	Yes	Yes	No		\$ 1,786,505	\$ -	\$ 107,190	13	10 Year
ULAR_694449_Block A Green Streets Program	ULAR	LASAN	City	Green Infrastructure	Distributed	Yes	Yes	No		\$ 924,779	\$ -	\$ 55,487	13	10 Year
ULAR_694549_Block A Green Streets Program	ULAR	LASAN	City	Green Infrastructure	Distributed	Yes	Yes	No		\$ 896,755	\$ -	\$ 53,805	13	10 Year
ULAR_694649_Block A Green Streets Program	ULAR	LASAN	City	Green Infrastructure	Distributed	Yes	Yes	No		\$ 1,198,009	\$ -	\$ 71,881	13	10 Year
ULAR_694849_Block A Green Streets Program	ULAR	LASAN	City	Green Infrastructure	Distributed	Yes	Yes	No		\$ 357,301	\$ -	\$ 21,438	13	10 Year
ULAR_694949_Block A Green Streets Program	ULAR	LASAN	City	Green Infrastructure	Distributed	Yes	Yes	No		\$ 1,583,333	\$ -	\$ 95,000	13	10 Year
ULAR_695049_Block A Green Streets Program	ULAR	LASAN	City	Green Infrastructure	Distributed	Yes	Yes	No		\$ 56,047	\$ -	\$ 3,363	13	10 Year
ULAR_695149_Block A Green Streets Program	ULAR	LASAN	City	Green Infrastructure	Distributed	Yes	Yes	No		\$ 2,094,764	\$ -	\$ 125,686	13	10 Year
ULAR_695249_Block A Green Streets Program	ULAR	LASAN	City	Green Infrastructure	Distributed	Yes	Yes	No		\$ 133,112	\$ -	\$ 7,987	13	10 Year
ULAR_695349_Block A Green Streets Program	ULAR	LASAN	City	Green Infrastructure	Distributed	Yes	Yes	No		\$ 140,118	\$ -	\$ 8,407	13	10 Year
ULAR_695449_Block A Green Streets Program	ULAR	LASAN	City	Green Infrastructure	Distributed	Yes	Yes	No		\$ 91,077	\$ -	\$ 5,465	13	10 Year
ULAR_695549_Block A Green Streets Program	ULAR	LASAN	City	Green Infrastructure	Distributed	Yes	Yes	No		\$ 21,018	\$ -	\$ 1,261	13	10 Year
ULAR_695849_Block A Green Streets Program	ULAR	LASAN	City	Green Infrastructure	Distributed	Yes	Yes	No		\$ 336,283	\$ -	\$ 20,177	13	10 Year
ULAR_695949_Block A Green Streets Program	ULAR	LASAN	City	Green Infrastructure	Distributed	Yes	Yes	No		\$ 63,053	\$ -	\$ 3,783	13	10 Year
ULAR_697449_Block A Green Streets Program	ULAR	LASAN	City	Green Infrastructure	Distributed	Yes	Yes	No		\$ 798,673	\$ -	\$ 47,920	13	10 Year
ULAR_697549_Block A Green Streets Program	ULAR	LASAN	City	Green Infrastructure	Distributed	Yes	Yes	No		\$ 1,891,593	\$ -	\$ 113,496	13	10 Year
ULAR_698049_Block A Green Streets Program	ULAR	LASAN	City	Green Infrastructure	Distributed	Yes	Yes	No		\$ 1,401,180	\$ -	\$ 84,071	13	10 Year
ULAR_698149_Block A Green Streets Program	ULAR	LASAN	City	Green Infrastructure	Distributed	Yes	Yes	No		\$ 294,248	\$ -	\$ 17,655	13	10 Year
ULAR_698249_Block A Green Streets Program	ULAR	LASAN	City	Green Infrastructure	Distributed	Yes	Yes	No		\$ 1,120,944	\$ -	\$ 67,257	13	10 Year
ULAR_698349_Block A Green Streets Program	ULAR	LASAN	City	Green Infrastructure	Distributed	Yes	Yes	No		\$ 1,828,540	\$ -	\$ 109,712	13	10 Year
ULAR_698549_Block A Green Streets Program	ULAR	LASAN	City	Green Infrastructure	Distributed	Yes	Yes	No		\$ 1,737,463	\$ -	\$ 104,248	13	10 Year
ULAR_698649_Block A Green Streets Program	ULAR	LASAN	City	Green Infrastructure	Distributed	Yes	Yes	No		\$ 511,431	\$ -	\$ 30,686	13	10 Year
ULAR_698749_Block A Green Streets Program	ULAR	LASAN	City	Green Infrastructure	Distributed	Yes	Yes	No		\$ 350,295	\$ -	\$ 21,018	13	10 Year
ULAR_698849_Block A Green Streets Program	ULAR	LASAN	City	Green Infrastructure	Distributed	Yes	Yes	No		\$ 98,083	\$ -	\$ 5,885	13	10 Year
ULAR_699149_Block A Green Streets Program	ULAR	LASAN	City	Green Infrastructure	Distributed	Yes	Yes	No		\$ 301,254	\$ -	\$ 18,075	13	10 Year
ULAR_699649_Block A Green Streets Program	ULAR	LASAN	City	Green Infrastructure	Distributed	Yes	Yes	No		\$ 1,275,074	\$ -	\$ 76,504	13	10 Year
ULAR_699749_Block A Green Streets Program	ULAR	LASAN	City	Green Infrastructure	Distributed	Yes	Yes	No		\$ 238,201	\$ -	\$ 14,292	13	10 Year
ULAR_699849_Block A Green Streets Program	ULAR	LASAN	City	Green Infrastructure	Distributed	Yes	Yes	No		\$ 175,148	\$ -	\$ 10,509	13	10 Year
ULAR_700049_Block A Green Streets Program	ULAR	LASAN	City	Green Infrastructure	Distributed	Yes	Yes	No		\$ 560,472	\$ -	\$ 33,628	13	10 Year
ULAR_700249_Block A Green Streets Program	ULAR	LASAN	City	Green Infrastructure	Distributed	Yes	Yes	No		\$ 644,543	\$ -	\$ 38,673	13	10 Year
ULAR_700349_Block A Green Streets Program	ULAR	LASAN	City	Green Infrastructure	Distributed	Yes	Yes	No		\$ 161,136	\$ -	\$ 9,668	13	10 Year
ULAR_700449_Block A Green Streets Program	ULAR	LASAN	City	Green Infrastructure	Distributed	Yes	Yes	No		\$ 49,041	\$ -	\$ 2,942	13	10 Year
ULAR_700649_Block A Green Streets Program	ULAR	LASAN	City	Green Infrastructure	Distributed	Yes	Yes	No		\$ 1,092,920	\$ -	\$ 65,575	13	10 Year
ULAR_700849_Block A Green Streets Program	ULAR	LASAN	City	Green Infrastructure	Distributed	Yes	Yes	No		\$ 385,325	\$ -	\$ 23,119	13	10 Year
ULAR_602449_Block A Green Streets Program	ULAR	LASAN	City	Green Infrastructure	Distributed	Yes	Yes	No		\$ 6,102,139	\$ -	\$ 366,128	13	10 Year
ULAR_604049_Block A Green Streets Program	ULAR	LASAN	City	Green Infrastructure	Distributed	Yes	Yes	No		\$ 3,601,033	\$ -	\$ 216,062	13	10 Year
ULAR_604549_Block A Green Streets Program	ULAR	LASAN	City	Green Infrastructure	Distributed	Yes	Yes	No		\$ 3,404,867	\$ -	\$ 204,292	13	10 Year
ULAR_604649_Block A Green Streets Program	ULAR	LASAN	City	Green Infrastructure	Distributed	Yes	Yes	No		\$ 2,529,130	\$ -	\$ 151,748	13	10 Year
ULAR_604749_Block A Green Streets Program	ULAR	LASAN	City	Green Infrastructure	Distributed	Yes	Yes	No		\$ 3,888,275	\$ -	\$ 233,296	13	10 Year
ULAR_605049_Block A Green Streets Program	ULAR	LASAN	City	Green Infrastructure	Distributed	Yes	Yes	No		\$ 10,165,561	\$ -	\$ 609,934	13	10 Year
ULAR_605149_Block A Green Streets Program	ULAR	LASAN	City	Green Infrastructure	Distributed	Yes	Yes	No		\$ 2,115,782	\$ -	\$ 126,947	13	10 Year
ULAR_605249_Block A Green Streets Program	ULAR	LASAN	City	Green Infrastructure	Distributed	Yes	Yes	No		\$ 6,109,145	\$ -	\$ 366,549	13	10 Year
ULAR_605349_Block A Green Streets Program	ULAR	LASAN	City	Green Infrastructure	Distributed	Yes	Yes	No		\$ 4,470,433	\$ -	\$ 268,226	13	10 Year
ULAR_605449_Block A Green Streets Program	ULAR	LASAN	City	Green Infrastructure	Distributed	Yes	Yes	No		\$ 6,823,747	\$ -	\$ 409,425	13	10 Year
ULAR_605549_Block A Green Streets Program	ULAR	LASAN	City	Green Infrastructure	Distributed	Yes	Yes	No		\$ 10,207,596	\$ -	\$ 612,456	13	10 Year
ULAR_605649_Block A Green Streets Program	ULAR	LASAN	City	Green Infrastructure	Distributed	Yes	Yes	No		\$ 2,297,935	\$ -	\$ 137,876	13	10 Year
ULAR_605749_Block A Green Streets Program	ULAR	LASAN	City	Green Infrastructure	Distributed	Yes	Yes	No		\$ 10,198,237	\$ -	\$ 611,894	13	10 Year
ULAR_605949_Block A Green Streets Program	ULAR	LASAN	City	Green Infrastructure	Distributed	Yes	Yes	No		\$ 3,418,879	\$ -	\$ 205,133	13	10 Year
ULAR_606149_Block A Green Streets Program	ULAR	LASAN	City	Green Infrastructure	Distributed	Yes	Yes	No		\$ 3,516,962	\$ -	\$ 211,018	13	10 Year
ULAR_606249_Block A Green Streets Program	ULAR	LASAN	City	Green Infrastructure	Distributed	Yes	Yes	No		\$ 2,360,988	\$ -	\$ 141,659	13	10 Year
ULAR_637749_Block A Green Streets Program	ULAR	LASAN	City	Green Infrastructure	Distributed	Yes	Yes	No		\$ 7,888,643	\$ -	\$ 473,319	13	10 Year
ULAR_638349_Block A Green Streets Program	ULAR	LASAN	City	Green Infrastructure	Distributed	Yes	Yes	No		\$ 5,023,230	\$ -	\$ 301,394	13	10 Year
ULAR_638549_Block A Green Streets Program	ULAR	LASAN	City	Green Infrastructure	Distributed	Yes	Yes	No		\$ 7,237,095	\$ -	\$ 434,226	13	10 Year
ULAR_638849_Block A Green Streets Program	ULAR	LASAN	City	Green Infrastructure	Distributed	Yes	Yes	No		\$ 2,431,047	\$ -	\$ 145,863	13	10 Year
ULAR_639249_Block A Green Streets Program	ULAR	LASAN	City	Green Infrastructure	Distributed	Yes	Yes	No		\$ 2,269,912	\$ -	\$ 136,195	13	10 Year
ULAR_640249_Block A Green Streets Program	ULAR	LASAN	City	Green Infrastructure	Distributed	Yes	Yes	No		\$ 2,353,982	\$ -	\$ 141,239	13	10 Year

Project Name	Watershed	Lead Agency	Project Type	Project Category	Project Size	Known Water Quality Benefit?	Known Water Supply Benefit ?	Known Flood Risk Mitigation Benefit?	Other Considerations	Green Infrastructure Capital Cost	Grey Infrastructure Capital Cost	Annual O&M Cost	Selection Order	SIP Phase
ULAR_640649_Block A Green Streets Program	ULAR	LASAN	City	Green Infrastructure	Distributed	Yes	Yes	No		\$ 3,117,626	\$ -	\$ 187,058	13	10 Year
ULAR_661949_Block A Green Streets Program	ULAR	LASAN	City	Green Infrastructure	Distributed	Yes	Yes	No		\$ 1,631,255	\$ -	\$ 97,875	13	10 Year
ULAR_662049_Block A Green Streets Program	ULAR	LASAN	City	Green Infrastructure	Distributed	Yes	Yes	No		\$ 589,266	\$ -	\$ 35,356	13	10 Year
ULAR_663949_Block A Green Streets Program	ULAR	LASAN	City	Green Infrastructure	Distributed	Yes	Yes	No		\$ 2,859,546	\$ -	\$ 171,573	13	10 Year
ULAR_664049_Block A Green Streets Program	ULAR	LASAN	City	Green Infrastructure	Distributed	Yes	Yes	No		\$ 2,375,000	\$ -	\$ 142,500	13	10 Year
ULAR_664149_Block A Green Streets Program	ULAR	LASAN	City	Green Infrastructure	Distributed	Yes	Yes	No		\$ 420,373	\$ -	\$ 25,222	13	10 Year
ULAR_664549_Block A Green Streets Program	ULAR	LASAN	City	Green Infrastructure	Distributed	Yes	Yes	No		\$ 1,612,052	\$ -	\$ 96,723	13	10 Year
ULAR_665049_Block A Green Streets Program	ULAR	LASAN	City	Green Infrastructure	Distributed	Yes	Yes	No		\$ 2,823,378	\$ -	\$ 169,403	13	10 Year
ULAR_667649_Block A Green Streets Program	ULAR	LASAN	City	Green Infrastructure	Distributed	Yes	Yes	No		\$ 11,952,065	\$ -	\$ 717,124	13	10 Year
ULAR_668749_Block A Green Streets Program	ULAR	LASAN	City	Green Infrastructure	Distributed	Yes	Yes	No		\$ 8,211,841	\$ -	\$ 492,710	13	10 Year
ULAR_683449_Block A Green Streets Program	ULAR	LASAN	City	Green Infrastructure	Distributed	Yes	Yes	No		\$ 2,662,242	\$ -	\$ 159,735	13	10 Year
ULAR_685649_Block A Green Streets Program	ULAR	LASAN	City	Green Infrastructure	Distributed	Yes	Yes	No		\$ 5,744,838	\$ -	\$ 344,690	13	10 Year
ULAR_689149_Block A Green Streets Program	ULAR	LASAN	City	Green Infrastructure	Distributed	Yes	Yes	No		\$ 2,494,100	\$ -	\$ 149,646	13	10 Year
ULAR_689249_Block A Green Streets Program	ULAR	LASAN	City	Green Infrastructure	Distributed	Yes	Yes	No		\$ 2,403,024	\$ -	\$ 144,181	13	10 Year
ULAR_691449_Block A Green Streets Program	ULAR	LASAN	City	Green Infrastructure	Distributed	Yes	Yes	No		\$ 1,577,736	\$ -	\$ 94,664	13	10 Year
ULAR_691949_Block A Green Streets Program	ULAR	LASAN	City	Green Infrastructure	Distributed	Yes	Yes	No		\$ 3,811,210	\$ -	\$ 228,673	13	10 Year
ULAR_692349_Block A Green Streets Program	ULAR	LASAN	City	Green Infrastructure	Distributed	Yes	Yes	No		\$ 5,212,390	\$ -	\$ 312,743	13	10 Year
ULAR_692549_Block A Green Streets Program	ULAR	LASAN	City	Green Infrastructure	Distributed	Yes	Yes	No		\$ 2,749,126	\$ -	\$ 164,948	13	10 Year
ULAR_692749_Block A Green Streets Program	ULAR	LASAN	City	Green Infrastructure	Distributed	Yes	Yes	No		\$ 4,658,924	\$ -	\$ 279,535	13	10 Year
ULAR_695649_Block A Green Streets Program	ULAR	LASAN	City	Green Infrastructure	Distributed	Yes	Yes	No		\$ 4,806,047	\$ -	\$ 288,363	13	10 Year
ULAR_695749_Block A Green Streets Program	ULAR	LASAN	City	Green Infrastructure	Distributed	Yes	Yes	No		\$ 4,890,118	\$ -	\$ 293,407	13	10 Year
ULAR_696049_Block A Green Streets Program	ULAR	LASAN	City	Green Infrastructure	Distributed	Yes	Yes	No		\$ 2,669,248	\$ -	\$ 160,155	13	10 Year
ULAR_697649_Block A Green Streets Program	ULAR	LASAN	City	Green Infrastructure	Distributed	Yes	Yes	No		\$ 6,424,410	\$ -	\$ 385,465	13	10 Year
ULAR_697749_Block A Green Streets Program	ULAR	LASAN	City	Green Infrastructure	Distributed	Yes	Yes	No		\$ 2,199,853	\$ -	\$ 131,991	13	10 Year
ULAR_697849_Block A Green Streets Program	ULAR	LASAN	City	Green Infrastructure	Distributed	Yes	Yes	No		\$ 2,543,142	\$ -	\$ 152,589	13	10 Year
ULAR_697949_Block A Green Streets Program	ULAR	LASAN	City	Green Infrastructure	Distributed	Yes	Yes	No		\$ 4,217,552	\$ -	\$ 253,053	13	10 Year
ULAR_699449_Block A Green Streets Program	ULAR	LASAN	City	Green Infrastructure	Distributed	Yes	Yes	No		\$ 2,396,018	\$ -	\$ 143,761	13	10 Year
ULAR_699549_Block A Green Streets Program	ULAR	LASAN	City	Green Infrastructure	Distributed	Yes	Yes	No		\$ 3,348,820	\$ -	\$ 200,929	13	10 Year
ULAR_699949_Block A Green Streets Program	ULAR	LASAN	City	Green Infrastructure	Distributed	Yes	Yes	No		\$ 2,886,431	\$ -	\$ 173,186	13	10 Year
Los Angeles River Natural Park	ULAR	LASAN/LADWP	City	Green Infrastructure	Centralized	Yes	Yes	Yes	Funding - LADWP	\$ 64,000,000	\$ -	\$ 3,200,000	14	10 Year
Albion Dairy Riverside Park	ULAR	LASAN	City	Green Infrastructure	Centralized	Yes	Yes	Yes	Open Space and Recreation	\$ 31,699,355	\$ -	\$ 1,584,968	14	10 Year
Bandini Power Line Easement	ULAR	LACFCD/LADWP	Partner	Green Infrastructure	Centralized	Yes	Yes	Yes	Funding - LADWP	\$ 100,000	\$ -	\$ 5,000	14	10 Year
Boulevard Pit Stormwater Capture Project	ULAR	LACFCD/LADWP	Partner	Green Infrastructure	Centralized	Yes	Yes	Yes	Funding - LADWP	\$ 118,000,000	\$ -	\$ 1,300,000	14	10 Year
Branford Spreading Basin Cleanout and Pump	ULAR	LACFCD/LADWP	Partner	Green Infrastructure	Centralized	Yes	Yes	Yes	Funding - LADWP	\$ 1,500,000	\$ -	\$ 36,000	14	10 Year
Bull Creek Los Angeles Reservoir Water Quality Improvement Project (Bull Creek Pipeline)	ULAR	LACFCD/LADWP	Partner	Green - Grey Infrastructure	Centralized	Yes	Yes	Yes	Funding - LADWP	\$ 75,000,000	\$ -	\$ 3,750,000	14	10 Year
Cal Mat Pit	ULAR	LASAN/LADWP	City	Green Infrastructure	Centralized	Yes	Yes	Yes	Funding-LADWP	\$ 10,000,000	\$ -	\$ 500,000	14	10 Year
Debris Basin Retrofit #1 (pilot)	ULAR	LASAN/LADWP	City	Green - Grey Infrastructure	Centralized	Yes	Yes	Yes	Funding - LADWP	\$ 2,000,000	\$ -	\$ 100,000	14	10 Year
Debris Basin Retrofit #2	ULAR	LASAN/LADWP	City	Green - Grey Infrastructure	Centralized	Yes	Yes	Yes	Funding - LADWP	\$ 2,000,000	\$ -	\$ 100,000	14	10 Year
Debris Basin Retrofit #3	ULAR	LASAN/LADWP	City	Green - Grey Infrastructure	Centralized	Yes	Yes	Yes	Funding - LADWP	\$ 2,000,000	\$ -	\$ 100,000	14	10 Year
Headworks Ecosystem Restoration	ULAR	LADWP	City	Green Infrastructure	Centralized	Yes	Yes	Yes	Habitat Restoration	\$ 14,000,000	\$ -	\$ 250,000	14	10 Year
LA Forebay Recharge System - LAR Full Scale	ULAR	LADWP/ LACFCD	City	Green - Grey Infrastructure	Centralized	Yes	Yes	Yes	Funding-LADWP	\$ 15,000,000	\$ -	\$ 750,000	14	10 Year
LA Forebay Recharge System - LAR Pilot	ULAR	LADWP/ LACFCD	City	Green - Grey Infrastructure	Centralized	Yes	Yes	Yes	Funding-LADWP	\$ 3,000,000	\$ -	\$ 150,000	14	10 Year
Lakeside Debris Basin	ULAR	LASAN/LADWP	City	Green - Grey Infrastructure	Centralized	Yes	Yes	Yes	Funding - LADWP	\$ 333,000	\$ -	\$ 16,650	14	10 Year
Panorama City Creek Restoration	ULAR	LA City CD6	City	Green Infrastructure	Centralized	Yes	Yes	Yes	Habitat Restoration	\$ 5,000,000	\$ -	\$ 100,000	14	10 Year
Parkway Retrofit TRP	ULAR	LACFCD/ LADWP	Partner	Green Infrastructure	Centralized	Yes	Yes	Yes	Funding - LADWP	\$ 5,700,000	\$ -	\$ 342,000	14	10 Year
Roscoe Power Facility project	ULAR	LADWP	City	Green Infrastructure	Centralized	Yes	Yes	Yes	Funding - LADWP	\$ 500,000	\$ -	\$ 30,000	14	10 Year
Sepulveda Basin - Hansen SG Pipe Line 54"	ULAR	LASAN/LADWP	City	Green - Grey Infrastructure	Centralized	Yes	Yes	Yes	Funding - LADWP	\$ 6,600,000	\$ -	\$ 330,000	14	10 Year
Sepulveda Basin Sports Complex Multi-Purpose Open Space Project	ULAR	LABOE	City	Green Infrastructure	Centralized	Yes	Yes	Yes	Open Space and Recreation	\$ 18,000,000	\$ -	\$ 900,000	14	10 Year
Sun Valley Parking Lot Infiltration	ULAR	LACFCD/ LADWP	Partner	Green Infrastructure	Centralized	Yes	Yes	Yes	Funding - LADWP	\$ 100,000	\$ -	\$ 5,000	14	10 Year
Valley Generating Station (LADWPsteam) Stormwater Capture - Ph I	ULAR	LACFCD/ LADWP	Partner	Green Infrastructure	Centralized	Yes	Yes	Yes	Funding - LADWP	\$ 2,000,000	\$ -	\$ 30,000	14	10 Year
Wenworth Park	ULAR	LASAN	City	Green Infrastructure	Centralized	Yes	Yes	Yes	Open Space and Recreation	\$ 500,000	\$ -	\$ 25,000	14	10 Year
Hansen Dam Water Conservation and Supply	ULAR	LACFCD/USACE/LADWP	Partner	Green Infrastructure	Centralized	Yes	Yes	Yes	Funding - LADWP	\$ 6,000,000	\$ -	\$ 100,000	15	10 Year
Big T & Pacoima Dam to LA Filtration Plant	ULAR	LACFCD/ LADWP	Partner	Green - Grey Infrastructure	Centralized	Yes	Yes	Yes	Funding - LADWP	\$ 80,000,000	\$ -	\$ 4,000,000	16	25 Year
Lopez Spreading Grounds Improvement	ULAR	LACFCD/ LADWP	Partner	Green Infrastructure	Centralized	Yes	Yes	Yes	Funding - LADWP	\$ 5,500,000	\$ -	\$ 50,000	16	25 Year
New Tujunga Spreading Grounds	ULAR	LACFCD/ LADWP	Partner	Green - Grey Infrastructure	Centralized	Yes	Yes	Yes	Funding - LADWP	\$ 394,650,187	\$ -	\$ 3,771,385	16	25 Year
Pacoima Reservoir Sediment Removal	ULAR	LACFCD/ LADWP	Partner	Green Infrastructure	Centralized	Yes	Yes	Yes	Funding - LADWP	\$ 85,000,000	\$ -	\$ -	16	25 Year

Project Name	Watershed	Lead Agency	Project Type	Project Category	Project Size	Known Water Quality Benefit?	Known Water Supply Benefit?	Known Flood Risk Mitigation Benefit?	Other Considerations	Green Infrastructure Capital Cost	Grey Infrastructure Capital Cost	Annual O&M Cost	Selection Order	SIP Phase
Pacoima Spreading Grounds Enhancements	ULAR	LACFCD/ LADWP	Partner	Green Infrastructure	Centralized	Yes	Yes	Yes	Funding - LADWP	\$ 32,000,000	\$ -	\$ 70,000	16	25 Year
Sheldon Pit Multiuse	ULAR	LACFCD/ LADWP	Partner	Green - Grey Infrastructure	Centralized	Yes	Yes	Yes	Funding - LADWP	\$ 75,000,000	\$ -	\$ 1,300,000	16	25 Year
Spreading Grounds Optimization	ULAR	LACFCD/ LADWP	Partner	Green - Grey Infrastructure	Centralized	Yes	Yes	Yes	Funding - LADWP	\$ 1,000,000	\$ -	\$ 50,000	16	25 Year
Storm Drain Mining (Capture and Use)	ULAR	LADWP	City	Green Infrastructure	Centralized	Yes	Yes	Yes	Funding-LADWP	\$ 3,000,000	\$ -	\$ 150,000	17	25 Year
Hansen Dam Wildlife Lake Improvement	ULAR	RAP/LADWP	City	Green Infrastructure	Centralized	Yes	Yes	Yes	Habitat Restoration	\$ 50,000,000	\$ -	\$ 300,000	18	25 Year
Humboldt Stormwater Greenway	ULAR	LASAN	City	Green Infrastructure	Centralized	Yes	Yes	Yes	Community Beautification	\$ 5,258,635	\$ -	\$ 30,000	18	25 Year
Lopez Canyon Basin	ULAR	LADWP	City	Green Infrastructure	Centralized	Yes	Yes	Yes	Funding-LADWP	\$ 5,000,000	\$ -	\$ 250,000	18	25 Year
Stonehurst Park	ULAR	LASAN	City	Green - Grey Infrastructure	Centralized	Yes	Yes	Yes	Open Space and Recreation	\$ 500,000	\$ -	\$ 25,000	18	25 Year
Verdugo Hills Golf Course Green Infrastructure	ULAR	LASAN	City	Green Infrastructure	Centralized	Yes	Yes	Yes	Open Space and Recreation	\$ 34,948,764	\$ -	\$ 90,000	18	25 Year
Hollywood Ave - La Brea to Gower Great Street	BC	LASAN/LADWP/LA Mayor's Office	City	Green Infrastructure	Distributed	Yes	Yes	Yes	Funding - LADWP	\$ 3,000,000	\$ -	\$ 180,000	19	25 Year
Reseda Blvd - Plummer to Parthenia Great Street	ULAR	LASAN/LADWP/LA Mayor's Office	City	Green Infrastructure	Distributed	Yes	Yes	Yes	Funding - LADWP	\$ 3,000,000	\$ -	\$ 180,000	19	25 Year
Western Ave - Melores to 3rd Great Street	ULAR	LASAN/LADWP/LA Mayor's Office	City	Green Infrastructure	Distributed	Yes	Yes	Yes	Funding - LADWP	\$ 3,000,000	\$ -	\$ 180,000	19	25 Year
Whitnall Gardens	ULAR	LASAN/LADWP	City	Green Infrastructure	Distributed	Yes	Yes	Yes	Funding - LADWP	\$ 2,000,000	\$ -	\$ 120,000	19	25 Year
Maclay Middle School	ULAR	LAUSD/LADWP	Partner	Green Infrastructure	Distributed	Yes	Yes	Yes	Funding - LADWP	\$ 100,000	\$ -	\$ 6,000	20	25 Year
Northridge Middle School	ULAR	LAUSD/LADWP	Partner	Green Infrastructure	Distributed	Yes	Yes	Yes	Funding - LADWP	\$ 100,000	\$ -	\$ 6,000	20	25 Year
Canterbury Powerline Easement Stormwater Capture	ULAR	LACFCD/ LADWP	Partner	Green Infrastructure	Centralized	Yes	Yes	No	Funding - LADWP	\$ 29,000,000	\$ -	\$ 55,540	21	25 Year
East Valley District Headquarters	ULAR	LABOE/LADWP	City	Green Infrastructure	Centralized	Yes	Yes	No	Funding - LADWP	\$ 2,000,000	\$ -	\$ 100,000	21	25 Year
LA Forebay Recharge System - Upper Ballona	ULAR	LADWP/ LACFCD	City	Green - Grey Infrastructure	Centralized	Yes	Yes	No	Funding-LADWP	\$ 3,000,000	\$ -	\$ 150,000	21	25 Year
North Hollywood Powerline	ULAR	LASAN/LADWP	City	Green Infrastructure	Centralized	Yes	Yes	No	Funding - LADWP	\$ 5,000,000	\$ -	\$ 250,000	21	25 Year
Park Retrofit #2	ULAR	RAP/LADWP	City	Green Infrastructure	Centralized	Yes	Yes	No	Open Space and Recreation	\$ 3,000,000	\$ -	\$ 150,000	21	25 Year
Park Retrofit #3	ULAR	RAP/LADWP	City	Green Infrastructure	Centralized	Yes	Yes	No	Open Space and Recreation	\$ 3,000,000	\$ -	\$ 150,000	21	25 Year
Silver Lake Stormwater Capture Project	ULAR	LASAN/LADWP	City	Green Infrastructure	Centralized	Yes	Yes	No	Funding - LADWP	\$ 5,000,000	\$ -	\$ 250,000	21	25 Year
Tujunga wash Outdoor Classroom	ULAR	LADWP	City	Green Infrastructure	Centralized	Yes	Yes	No	Community Beautification	\$ 1,000,000	\$ -	\$ 50,000	21	25 Year
Valley Center Yard SWCP	ULAR	LASAN/LADWP	City	Green Infrastructure	Centralized	Yes	Yes	No	Funding - LADWP	\$ 1,000,000	\$ -	\$ 50,000	21	25 Year
Valley Generating Station Stormwater Capture - II	ULAR	LACFCD/LADWP	Partner	Green Infrastructure	Centralized	Yes	Yes	No	Funding - LADWP	\$ 10,000,000	\$ -	\$ 500,000	21	25 Year
Van Norman Stormwater Capture	ULAR	LACFCD/LADWP	Partner	Green Infrastructure	Centralized	Yes	Yes	No	Funding - LADWP	\$ 40,000,000	\$ -	\$ 2,000,000	21	25 Year
Van Nuys Airport	ULAR	LADWP	City	Green Infrastructure	Centralized	Yes	Yes	No	Funding - LADWP	\$ 16,000,000	\$ -	\$ 800,000	21	25 Year
Whiteman Airport (Roger Jessup Park)	ULAR	LASAN/LADWP	City	Green Infrastructure	Centralized	Yes	Yes	No	Funding - LADWP	\$ 7,500,000	\$ -	\$ 375,000	21	25 Year
Harbor City Park	DC	LASAN	City	Green Infrastructure	Centralized	Yes	Yes	No	Open Space and Recreation	\$ 71,994,000	\$ -	\$ 3,599,700	22	25 Year
Taylor Yard River Park - Parcel G2	ULAR	LABOE/USACE	Partner	Green Infrastructure	Centralized	Yes	Yes	No	Habitat Restoration	\$ 272,000,000	\$ -	\$ 230,000	22	25 Year
Erwin Well Lot Infiltration Basin	ULAR	LABOE/LADWP	City	Green Infrastructure	Distributed	Yes	Yes	No	Funding - LADWP	\$ 1,500,000	\$ -	\$ 90,000	23	25 Year
Grace Community Church of the Valley Parking Retrofit	ULAR	LA City CD6	City	Green Infrastructure	Distributed	Yes	Yes	No	Community Beautification	\$ 300,000	\$ -	\$ 18,000	23	25 Year
Laurel Canyon Boulevard Green Street Project	ULAR	LASAN/LADWP	City	Green Infrastructure	Distributed	Yes	Yes	No	Funding - LADWP	\$ 3,000,000	\$ -	\$ 180,000	23	25 Year
Magnolia - Vineland to Cahuenga	ULAR	LASAN/LADWP	City	Green Infrastructure	Distributed	Yes	Yes	No	Community Beautification	\$ 3,000,000	\$ -	\$ 180,000	23	25 Year
Pacoima Median and Bike Trial	ULAR	LA City CD7	City	Green Infrastructure	Distributed	Yes	Yes	No	Community Beautification	\$ 3,000,000	\$ -	\$ 100,000	23	25 Year
San Fernando Road Swales	ULAR	LACFCD/ LADWP	Partner	Green Infrastructure	Distributed	Yes	Yes	No	Funding - LADWP	\$ 6,000,000	\$ -	\$ 300,000	23	25 Year
Sheldon Green Street	ULAR	LASAN/LADWP	City	Green Infrastructure	Distributed	Yes	Yes	No	Funding - LADWP	\$ 9,375,000	\$ -	\$ 562,500	23	25 Year
Subwatershed R2-G Green Streets	ULAR	LASAN	City	Green Infrastructure	Distributed	Yes	Yes	No	Community Beautification	\$ 10,700,000	\$ -	\$ 642,000	23	25 Year
Subwatershed R2-J Green Streets	ULAR	LASAN	City	Green Infrastructure	Distributed	Yes	Yes	No	Community Beautification	\$ 10,700,000	\$ -	\$ 642,000	23	25 Year
Tyrone Yard Property	ULAR	LADWP	City	Green Infrastructure	Distributed	Yes	Yes	No	Funding - LADWP	\$ 3,000,000	\$ -	\$ 180,000	23	25 Year
Van Nuys Blvd Pocket Parks	ULAR	LA City CD7	City	Green Infrastructure	Distributed	Yes	Yes	No	Community Beautification	\$ 5,000,000	\$ -	\$ 100,000	23	25 Year
Van Nuys Blvd. Median Infiltration	ULAR	LASAN/LADWP	City	Green Infrastructure	Distributed	Yes	Yes	No	Funding - LADWP	\$ 2,000,000	\$ -	\$ 120,000	23	25 Year
Victory-Encino Median SWCP	ULAR	LASAN/LADWP/LABSS	City	Green Infrastructure	Distributed	Yes	Yes	No	Funding - LADWP	\$ 2,300,000	\$ -	\$ 138,000	23	25 Year
Wyngate Street Pocket Park	ULAR	LA City CD2	City	Green Infrastructure	Distributed	Yes	Yes	No	Community Beautification	\$ 5,000,000	\$ -	\$ 100,000	23	25 Year
DC_Dominguez Channel Estuary_Block C Green Streets Program	DC	LASAN	City	Green Infrastructure	Distributed	Yes	Yes	No		\$ 14,700,107	\$ -	\$ 882,006	24	25 Year
DC_Dominguez Channel_Block C Green Streets Program	DC	LASAN	City	Green Infrastructure	Distributed	Yes	Yes	No		\$ 7,616,561	\$ -	\$ 456,994	24	25 Year
ULAR_604349_Block B Green Streets Program	ULAR	LASAN	City	Green Infrastructure	Distributed	Yes	Yes	No		\$ 11,025,519	\$ -	\$ 661,531	24	25 Year
ULAR_638449_Block B Green Streets Program	ULAR	LASAN	City	Green Infrastructure	Distributed	Yes	Yes	No		\$ 13,720,450	\$ -	\$ 823,227	24	25 Year
ULAR_664949_Block B Green Streets Program	ULAR	LASAN	City	Green Infrastructure	Distributed	Yes	Yes	No		\$ 16,758,113	\$ -	\$ 1,005,487	24	25 Year
ULAR_692849_Block B Green Streets Program	ULAR	LASAN	City	Green Infrastructure	Distributed	Yes	Yes	No		\$ 16,740,462	\$ -	\$ 1,004,428	24	25 Year
ULAR_603649_Block B Green Streets Program	ULAR	LASAN	City	Green Infrastructure	Distributed	Yes	Yes	No		\$ 1,120,944	\$ -	\$ 67,257	24	25 Year
ULAR_603949_Block B Green Streets Program	ULAR	LASAN	City	Green Infrastructure	Distributed	Yes	Yes	No		\$ 63,053	\$ -	\$ 3,783	24	25 Year
ULAR_604149_Block B Green Streets Program	ULAR	LASAN	City	Green Infrastructure	Distributed	Yes	Yes	No		\$ 1,275,074	\$ -	\$ 76,504	24	25 Year
ULAR_604249_Block B Green Streets Program	ULAR	LASAN	City	Green Infrastructure	Distributed	Yes	Yes	No		\$ 581,490	\$ -	\$ 34,889	24	25 Year
ULAR_604449_Block B Green Streets Program	ULAR	LASAN	City	Green Infrastructure	Distributed	Yes	Yes	No		\$ 1,366,151	\$ -	\$ 81,969	24	25 Year
ULAR_604949_Block B Green Streets Program	ULAR	LASAN	City	Green Infrastructure	Distributed	Yes	Yes	No		\$ 1,078,909	\$ -	\$ 64,735	24	25 Year
ULAR_605849_Block B Green Streets Program	ULAR	LASAN	City	Green Infrastructure	Distributed	Yes	Yes	No		\$ 2,017,699	\$ -	\$ 121,062	24	25 Year

Project Name	Watershed	Lead Agency	Project Type	Project Category	Project Size	Known Water Quality Benefit?	Known Water Supply Benefit?	Known Flood Risk Mitigation Benefit?	Other Considerations	Green Infrastructure Capital Cost	Grey Infrastructure Capital Cost	Annual O&M Cost	Selection Order	SIP Phase
ULAR_606349_Block B Green Streets Program	ULAR	LASAN	City	Green Infrastructure	Distributed	Yes	Yes	No		\$ 1,106,932	\$ -	\$ 66,416	24	25 Year
ULAR_606449_Block B Green Streets Program	ULAR	LASAN	City	Green Infrastructure	Distributed	Yes	Yes	No		\$ 1,485,251	\$ -	\$ 89,115	24	25 Year
ULAR_635849_Block B Green Streets Program	ULAR	LASAN	City	Green Infrastructure	Distributed	Yes	Yes	No		\$ 14,012	\$ -	\$ 841	24	25 Year
ULAR_635949_Block B Green Streets Program	ULAR	LASAN	City	Green Infrastructure	Distributed	Yes	Yes	No		\$ 455,384	\$ -	\$ 27,323	24	25 Year
ULAR_636849_Block B Green Streets Program	ULAR	LASAN	City	Green Infrastructure	Distributed	Yes	Yes	No		\$ 14,012	\$ -	\$ 841	24	25 Year
ULAR_637049_Block B Green Streets Program	ULAR	LASAN	City	Green Infrastructure	Distributed	Yes	Yes	No		\$ 7,006	\$ -	\$ 420	24	25 Year
ULAR_638249_Block B Green Streets Program	ULAR	LASAN	City	Green Infrastructure	Distributed	Yes	Yes	No		\$ 14,012	\$ -	\$ 841	24	25 Year
ULAR_639449_Block B Green Streets Program	ULAR	LASAN	City	Green Infrastructure	Distributed	Yes	Yes	No		\$ 1,015,856	\$ -	\$ 60,951	24	25 Year
ULAR_639549_Block B Green Streets Program	ULAR	LASAN	City	Green Infrastructure	Distributed	Yes	Yes	No		\$ 1,127,950	\$ -	\$ 67,677	24	25 Year
ULAR_639749_Block B Green Streets Program	ULAR	LASAN	City	Green Infrastructure	Distributed	Yes	Yes	No		\$ 686,578	\$ -	\$ 41,195	24	25 Year
ULAR_639949_Block B Green Streets Program	ULAR	LASAN	City	Green Infrastructure	Distributed	Yes	Yes	No		\$ 84,071	\$ -	\$ 5,044	24	25 Year
ULAR_640049_Block B Green Streets Program	ULAR	LASAN	City	Green Infrastructure	Distributed	Yes	Yes	No		\$ 105,089	\$ -	\$ 6,305	24	25 Year
ULAR_640749_Block B Green Streets Program	ULAR	LASAN	City	Green Infrastructure	Distributed	Yes	Yes	No		\$ 2,024,705	\$ -	\$ 121,482	24	25 Year
ULAR_640849_Block B Green Streets Program	ULAR	LASAN	City	Green Infrastructure	Distributed	Yes	Yes	No		\$ 1,583,157	\$ -	\$ 94,989	24	25 Year
ULAR_640949_Block B Green Streets Program	ULAR	LASAN	City	Green Infrastructure	Distributed	Yes	Yes	No		\$ 301,254	\$ -	\$ 18,075	24	25 Year
ULAR_641049_Block B Green Streets Program	ULAR	LASAN	City	Green Infrastructure	Distributed	Yes	Yes	No		\$ 1,141,962	\$ -	\$ 68,518	24	25 Year
ULAR_641149_Block B Green Streets Program	ULAR	LASAN	City	Green Infrastructure	Distributed	Yes	Yes	No		\$ 483,407	\$ -	\$ 29,004	24	25 Year
ULAR_647649_Block B Green Streets Program	ULAR	LASAN	City	Green Infrastructure	Distributed	Yes	Yes	No		\$ 742,625	\$ -	\$ 44,558	24	25 Year
ULAR_649149_Block B Green Streets Program	ULAR	LASAN	City	Green Infrastructure	Distributed	Yes	Yes	No		\$ 77,065	\$ -	\$ 4,624	24	25 Year
ULAR_649449_Block B Green Streets Program	ULAR	LASAN	City	Green Infrastructure	Distributed	Yes	Yes	No		\$ 133,112	\$ -	\$ 7,987	24	25 Year
ULAR_649549_Block B Green Streets Program	ULAR	LASAN	City	Green Infrastructure	Distributed	Yes	Yes	No		\$ 1,183,997	\$ -	\$ 71,040	24	25 Year
ULAR_649649_Block B Green Streets Program	ULAR	LASAN	City	Green Infrastructure	Distributed	Yes	Yes	No		\$ 595,502	\$ -	\$ 35,730	24	25 Year
ULAR_651249_Block B Green Streets Program	ULAR	LASAN	City	Green Infrastructure	Distributed	Yes	Yes	No		\$ 182,153	\$ -	\$ 10,929	24	25 Year
ULAR_657149_Block B Green Streets Program	ULAR	LASAN	City	Green Infrastructure	Distributed	Yes	Yes	No		\$ 301,254	\$ -	\$ 18,075	24	25 Year
ULAR_660349_Block B Green Streets Program	ULAR	LASAN	City	Green Infrastructure	Distributed	Yes	Yes	No		\$ 791,667	\$ -	\$ 47,500	24	25 Year
ULAR_661049_Block B Green Streets Program	ULAR	LASAN	City	Green Infrastructure	Distributed	Yes	Yes	No		\$ 28,024	\$ -	\$ 1,681	24	25 Year
ULAR_661249_Block B Green Streets Program	ULAR	LASAN	City	Green Infrastructure	Distributed	Yes	Yes	No		\$ 777,655	\$ -	\$ 46,659	24	25 Year
ULAR_661749_Block B Green Streets Program	ULAR	LASAN	City	Green Infrastructure	Distributed	Yes	Yes	No		\$ 294,248	\$ -	\$ 17,655	24	25 Year
ULAR_661849_Block B Green Streets Program	ULAR	LASAN	City	Green Infrastructure	Distributed	Yes	Yes	No		\$ 889,749	\$ -	\$ 53,385	24	25 Year
ULAR_662249_Block B Green Streets Program	ULAR	LASAN	City	Green Infrastructure	Distributed	Yes	Yes	No		\$ 266,224	\$ -	\$ 15,973	24	25 Year
ULAR_662949_Block B Green Streets Program	ULAR	LASAN	City	Green Infrastructure	Distributed	Yes	Yes	No		\$ 1,169,985	\$ -	\$ 70,199	24	25 Year
ULAR_663549_Block B Green Streets Program	ULAR	LASAN	City	Green Infrastructure	Distributed	Yes	Yes	No		\$ 28,024	\$ -	\$ 1,681	24	25 Year
ULAR_663649_Block B Green Streets Program	ULAR	LASAN	City	Green Infrastructure	Distributed	Yes	Yes	No		\$ 217,183	\$ -	\$ 13,031	24	25 Year
ULAR_663749_Block B Green Streets Program	ULAR	LASAN	City	Green Infrastructure	Distributed	Yes	Yes	No		\$ 308,260	\$ -	\$ 18,496	24	25 Year
ULAR_663849_Block B Green Streets Program	ULAR	LASAN	City	Green Infrastructure	Distributed	Yes	Yes	No		\$ 7,006	\$ -	\$ 420	24	25 Year
ULAR_664649_Block B Green Streets Program	ULAR	LASAN	City	Green Infrastructure	Distributed	Yes	Yes	No		\$ 791,667	\$ -	\$ 47,500	24	25 Year
ULAR_664749_Block B Green Streets Program	ULAR	LASAN	City	Green Infrastructure	Distributed	Yes	Yes	No		\$ 1,303,097	\$ -	\$ 78,186	24	25 Year
ULAR_665349_Block B Green Streets Program	ULAR	LASAN	City	Green Infrastructure	Distributed	Yes	Yes	No		\$ 623,525	\$ -	\$ 37,412	24	25 Year
ULAR_665549_Block B Green Streets Program	ULAR	LASAN	City	Green Infrastructure	Distributed	Yes	Yes	No		\$ 560,472	\$ -	\$ 33,628	24	25 Year
ULAR_665749_Block B Green Streets Program	ULAR	LASAN	City	Green Infrastructure	Distributed	Yes	Yes	No		\$ 49,041	\$ -	\$ 2,942	24	25 Year
ULAR_665949_Block B Green Streets Program	ULAR	LASAN	City	Green Infrastructure	Distributed	Yes	Yes	No		\$ 987,832	\$ -	\$ 59,270	24	25 Year
ULAR_666149_Block B Green Streets Program	ULAR	LASAN	City	Green Infrastructure	Distributed	Yes	Yes	No		\$ 1,485,251	\$ -	\$ 89,115	24	25 Year
ULAR_666249_Block B Green Streets Program	ULAR	LASAN	City	Green Infrastructure	Distributed	Yes	Yes	No		\$ 1,726,189	\$ -	\$ 103,571	24	25 Year
ULAR_666349_Block B Green Streets Program	ULAR	LASAN	City	Green Infrastructure	Distributed	Yes	Yes	No		\$ 546,460	\$ -	\$ 32,788	24	25 Year
ULAR_666449_Block B Green Streets Program	ULAR	LASAN	City	Green Infrastructure	Distributed	Yes	Yes	No		\$ 326,575	\$ -	\$ 19,595	24	25 Year
ULAR_666549_Block B Green Streets Program	ULAR	LASAN	City	Green Infrastructure	Distributed	Yes	Yes	No		\$ 357,301	\$ -	\$ 21,438	24	25 Year
ULAR_667849_Block B Green Streets Program	ULAR	LASAN	City	Green Infrastructure	Distributed	Yes	Yes	No		\$ 7,006	\$ -	\$ 420	24	25 Year
ULAR_667949_Block B Green Streets Program	ULAR	LASAN	City	Green Infrastructure	Distributed	Yes	Yes	No		\$ 126,106	\$ -	\$ 7,566	24	25 Year
ULAR_668449_Block B Green Streets Program	ULAR	LASAN	City	Green Infrastructure	Distributed	Yes	Yes	No		\$ 1,094,735	\$ -	\$ 65,684	24	25 Year
ULAR_669349_Block B Green Streets Program	ULAR	LASAN	City	Green Infrastructure	Distributed	Yes	Yes	No		\$ 1,205,015	\$ -	\$ 72,301	24	25 Year
ULAR_669749_Block B Green Streets Program	ULAR	LASAN	City	Green Infrastructure	Distributed	Yes	Yes	No		\$ 56,047	\$ -	\$ 3,363	24	25 Year
ULAR_672849_Block B Green Streets Program	ULAR	LASAN	City	Green Infrastructure	Distributed	Yes	Yes	No		\$ 7,006	\$ -	\$ 420	24	25 Year
ULAR_673949_Block B Green Streets Program	ULAR	LASAN	City	Green Infrastructure	Distributed	Yes	Yes	No		\$ 14,012	\$ -	\$ 841	24	25 Year
ULAR_682949_Block B Green Streets Program	ULAR	LASAN	City	Green Infrastructure	Distributed	Yes	Yes	No		\$ 420,354	\$ -	\$ 25,221	24	25 Year
ULAR_683049_Block B Green Streets Program	ULAR	LASAN	City	Green Infrastructure	Distributed	Yes	Yes	No		\$ 161,136	\$ -	\$ 9,668	24	25 Year
ULAR_683149_Block B Green Streets Program	ULAR	LASAN	City	Green Infrastructure	Distributed	Yes	Yes	No		\$ 945,797	\$ -	\$ 56,748	24	25 Year
ULAR_683649_Block B Green Streets Program	ULAR	LASAN	City	Green Infrastructure	Distributed	Yes	Yes	No		\$ 1,015,856	\$ -	\$ 60,951	24	25 Year
ULAR_685349_Block B Green Streets Program	ULAR	LASAN	City	Green Infrastructure	Distributed	Yes	Yes	No		\$ 427,360	\$ -	\$ 25,642	24	25 Year
ULAR_686049_Block B Green Streets Program	ULAR	LASAN	City	Green Infrastructure	Distributed	Yes	Yes	No		\$ 7,006	\$ -	\$ 420	24	25 Year
ULAR_686249_Block B Green Streets Program	ULAR	LASAN	City	Green Infrastructure	Distributed	Yes	Yes	No		\$ 896,755	\$ -	\$ 53,805	24	25 Year
ULAR_686449_Block B Green Streets Program	ULAR	LASAN	City	Green Infrastructure	Distributed	Yes	Yes	No		\$ 91,077	\$ -	\$ 5,465	24	25 Year
ULAR_686649_Block B Green Streets Program	ULAR	LASAN	City	Green Infrastructure	Distributed	Yes	Yes	No		\$ 259,218	\$ -	\$ 15,553	24	25 Year
ULAR_686849_Block B Green Streets Program	ULAR	LASAN	City	Green Infrastructure	Distributed	Yes	Yes	No		\$ 1,092,920	\$ -	\$ 65,575	24	25 Year
ULAR_687249_Block B Green Streets Program	ULAR	LASAN	City	Green Infrastructure	Distributed	Yes	Yes	No		\$ 2,024,705	\$ -	\$ 121,482	24	25 Year
ULAR_687349_Block B Green Streets Program	ULAR	LASAN	City	Green Infrastructure	Distributed	Yes	Yes	No		\$ 105,089	\$ -	\$ 6,305	24	25 Year
ULAR_687449_Block B Green Streets Program	ULAR	LASAN	City	Green Infrastructure	Distributed	Yes	Yes	No		\$ 126,106	\$ -	\$ 7,566	24	25 Year
ULAR_687549_Block B Green Streets Program	ULAR	LASAN	City	Green Infrastructure	Distributed	Yes	Yes	No		\$ 1,996,682	\$ -	\$ 119,801	24	25 Year
ULAR_687849_Block B Green Streets Program	ULAR	LASAN	City	Green Infrastructure	Distributed	Yes	Yes	No		\$ 385,325	\$ -	\$ 23,119	24	25 Year
ULAR_688049_Block B Green Streets Program	ULAR	LASAN	City	Green Infrastructure	Distributed	Yes	Yes	No		\$ 7,006	\$ -	\$ 420	24	25 Year

Project Name	Watershed	Lead Agency	Project Type	Project Category	Project Size	Known Water Quality Benefit?	Known Water Supply Benefit?	Known Flood Risk Mitigation Benefit?	Other Considerations	Green Infrastructure Capital Cost	Grey Infrastructure Capital Cost	Annual O&M Cost	Selection Order	SIP Phase
ULAR_688549_Block B Green Streets Program	ULAR	LASAN	City	Green Infrastructure	Distributed	Yes	Yes	No		\$ 1,506,269	\$ -	\$ 90,376	24	25 Year
ULAR_688749_Block B Green Streets Program	ULAR	LASAN	City	Green Infrastructure	Distributed	Yes	Yes	No		\$ 889,749	\$ -	\$ 53,385	24	25 Year
ULAR_688849_Block B Green Streets Program	ULAR	LASAN	City	Green Infrastructure	Distributed	Yes	Yes	No		\$ 1,113,938	\$ -	\$ 66,836	24	25 Year
ULAR_688949_Block B Green Streets Program	ULAR	LASAN	City	Green Infrastructure	Distributed	Yes	Yes	No		\$ 1,324,115	\$ -	\$ 79,447	24	25 Year
ULAR_689349_Block B Green Streets Program	ULAR	LASAN	City	Green Infrastructure	Distributed	Yes	Yes	No		\$ 98,083	\$ -	\$ 5,885	24	25 Year
ULAR_690249_Block B Green Streets Program	ULAR	LASAN	City	Green Infrastructure	Distributed	Yes	Yes	No		\$ 763,643	\$ -	\$ 45,819	24	25 Year
ULAR_691149_Block B Green Streets Program	ULAR	LASAN	City	Green Infrastructure	Distributed	Yes	Yes	No		\$ 126,106	\$ -	\$ 7,566	24	25 Year
ULAR_691249_Block B Green Streets Program	ULAR	LASAN	City	Green Infrastructure	Distributed	Yes	Yes	No		\$ 1,268,068	\$ -	\$ 76,084	24	25 Year
ULAR_691349_Block B Green Streets Program	ULAR	LASAN	City	Green Infrastructure	Distributed	Yes	Yes	No		\$ 42,035	\$ -	\$ 2,522	24	25 Year
ULAR_691549_Block B Green Streets Program	ULAR	LASAN	City	Green Infrastructure	Distributed	Yes	Yes	No		\$ 399,336	\$ -	\$ 23,960	24	25 Year
ULAR_691649_Block B Green Streets Program	ULAR	LASAN	City	Green Infrastructure	Distributed	Yes	Yes	No		\$ 2,101,770	\$ -	\$ 126,106	24	25 Year
ULAR_691849_Block B Green Streets Program	ULAR	LASAN	City	Green Infrastructure	Distributed	Yes	Yes	No		\$ 70,059	\$ -	\$ 4,204	24	25 Year
ULAR_692149_Block B Green Streets Program	ULAR	LASAN	City	Green Infrastructure	Distributed	Yes	Yes	No		\$ 7,006	\$ -	\$ 420	24	25 Year
ULAR_692249_Block B Green Streets Program	ULAR	LASAN	City	Green Infrastructure	Distributed	Yes	Yes	No		\$ 798,673	\$ -	\$ 47,920	24	25 Year
ULAR_692449_Block B Green Streets Program	ULAR	LASAN	City	Green Infrastructure	Distributed	Yes	Yes	No		\$ 1,401,180	\$ -	\$ 84,071	24	25 Year
ULAR_693449_Block B Green Streets Program	ULAR	LASAN	City	Green Infrastructure	Distributed	Yes	Yes	No		\$ 378,319	\$ -	\$ 22,699	24	25 Year
ULAR_694149_Block B Green Streets Program	ULAR	LASAN	City	Green Infrastructure	Distributed	Yes	Yes	No		\$ 7,006	\$ -	\$ 420	24	25 Year
ULAR_694249_Block B Green Streets Program	ULAR	LASAN	City	Green Infrastructure	Distributed	Yes	Yes	No		\$ 721,608	\$ -	\$ 43,296	24	25 Year
ULAR_694349_Block B Green Streets Program	ULAR	LASAN	City	Green Infrastructure	Distributed	Yes	Yes	No		\$ 1,786,505	\$ -	\$ 107,190	24	25 Year
ULAR_694449_Block B Green Streets Program	ULAR	LASAN	City	Green Infrastructure	Distributed	Yes	Yes	No		\$ 924,779	\$ -	\$ 55,487	24	25 Year
ULAR_694549_Block B Green Streets Program	ULAR	LASAN	City	Green Infrastructure	Distributed	Yes	Yes	No		\$ 896,755	\$ -	\$ 53,805	24	25 Year
ULAR_694649_Block B Green Streets Program	ULAR	LASAN	City	Green Infrastructure	Distributed	Yes	Yes	No		\$ 1,198,009	\$ -	\$ 71,881	24	25 Year
ULAR_694849_Block B Green Streets Program	ULAR	LASAN	City	Green Infrastructure	Distributed	Yes	Yes	No		\$ 357,301	\$ -	\$ 21,438	24	25 Year
ULAR_694949_Block B Green Streets Program	ULAR	LASAN	City	Green Infrastructure	Distributed	Yes	Yes	No		\$ 1,583,333	\$ -	\$ 95,000	24	25 Year
ULAR_695049_Block B Green Streets Program	ULAR	LASAN	City	Green Infrastructure	Distributed	Yes	Yes	No		\$ 56,047	\$ -	\$ 3,363	24	25 Year
ULAR_695149_Block B Green Streets Program	ULAR	LASAN	City	Green Infrastructure	Distributed	Yes	Yes	No		\$ 2,094,764	\$ -	\$ 125,686	24	25 Year
ULAR_695249_Block B Green Streets Program	ULAR	LASAN	City	Green Infrastructure	Distributed	Yes	Yes	No		\$ 133,112	\$ -	\$ 7,987	24	25 Year
ULAR_695349_Block B Green Streets Program	ULAR	LASAN	City	Green Infrastructure	Distributed	Yes	Yes	No		\$ 140,118	\$ -	\$ 8,407	24	25 Year
ULAR_695449_Block B Green Streets Program	ULAR	LASAN	City	Green Infrastructure	Distributed	Yes	Yes	No		\$ 91,077	\$ -	\$ 5,465	24	25 Year
ULAR_695549_Block B Green Streets Program	ULAR	LASAN	City	Green Infrastructure	Distributed	Yes	Yes	No		\$ 21,018	\$ -	\$ 1,261	24	25 Year
ULAR_695849_Block B Green Streets Program	ULAR	LASAN	City	Green Infrastructure	Distributed	Yes	Yes	No		\$ 336,283	\$ -	\$ 20,177	24	25 Year
ULAR_695949_Block B Green Streets Program	ULAR	LASAN	City	Green Infrastructure	Distributed	Yes	Yes	No		\$ 63,053	\$ -	\$ 3,783	24	25 Year
ULAR_697449_Block B Green Streets Program	ULAR	LASAN	City	Green Infrastructure	Distributed	Yes	Yes	No		\$ 798,673	\$ -	\$ 47,920	24	25 Year
ULAR_697549_Block B Green Streets Program	ULAR	LASAN	City	Green Infrastructure	Distributed	Yes	Yes	No		\$ 1,891,593	\$ -	\$ 113,496	24	25 Year
ULAR_698049_Block B Green Streets Program	ULAR	LASAN	City	Green Infrastructure	Distributed	Yes	Yes	No		\$ 1,401,180	\$ -	\$ 84,071	24	25 Year
ULAR_698149_Block B Green Streets Program	ULAR	LASAN	City	Green Infrastructure	Distributed	Yes	Yes	No		\$ 294,248	\$ -	\$ 17,655	24	25 Year
ULAR_698249_Block B Green Streets Program	ULAR	LASAN	City	Green Infrastructure	Distributed	Yes	Yes	No		\$ 1,120,944	\$ -	\$ 67,257	24	25 Year
ULAR_698349_Block B Green Streets Program	ULAR	LASAN	City	Green Infrastructure	Distributed	Yes	Yes	No		\$ 1,828,540	\$ -	\$ 109,712	24	25 Year
ULAR_698549_Block B Green Streets Program	ULAR	LASAN	City	Green Infrastructure	Distributed	Yes	Yes	No		\$ 1,737,463	\$ -	\$ 104,248	24	25 Year
ULAR_698649_Block B Green Streets Program	ULAR	LASAN	City	Green Infrastructure	Distributed	Yes	Yes	No		\$ 511,431	\$ -	\$ 30,686	24	25 Year
ULAR_698749_Block B Green Streets Program	ULAR	LASAN	City	Green Infrastructure	Distributed	Yes	Yes	No		\$ 350,295	\$ -	\$ 21,018	24	25 Year
ULAR_698849_Block B Green Streets Program	ULAR	LASAN	City	Green Infrastructure	Distributed	Yes	Yes	No		\$ 98,083	\$ -	\$ 5,885	24	25 Year
ULAR_699149_Block B Green Streets Program	ULAR	LASAN	City	Green Infrastructure	Distributed	Yes	Yes	No		\$ 301,254	\$ -	\$ 18,075	24	25 Year
ULAR_699649_Block B Green Streets Program	ULAR	LASAN	City	Green Infrastructure	Distributed	Yes	Yes	No		\$ 1,275,074	\$ -	\$ 76,504	24	25 Year
ULAR_699749_Block B Green Streets Program	ULAR	LASAN	City	Green Infrastructure	Distributed	Yes	Yes	No		\$ 238,201	\$ -	\$ 14,292	24	25 Year
ULAR_699849_Block B Green Streets Program	ULAR	LASAN	City	Green Infrastructure	Distributed	Yes	Yes	No		\$ 175,148	\$ -	\$ 10,509	24	25 Year
ULAR_700049_Block B Green Streets Program	ULAR	LASAN	City	Green Infrastructure	Distributed	Yes	Yes	No		\$ 560,472	\$ -	\$ 33,628	24	25 Year
ULAR_700249_Block B Green Streets Program	ULAR	LASAN	City	Green Infrastructure	Distributed	Yes	Yes	No		\$ 644,543	\$ -	\$ 38,673	24	25 Year
ULAR_700349_Block B Green Streets Program	ULAR	LASAN	City	Green Infrastructure	Distributed	Yes	Yes	No		\$ 161,136	\$ -	\$ 9,668	24	25 Year
ULAR_700449_Block B Green Streets Program	ULAR	LASAN	City	Green Infrastructure	Distributed	Yes	Yes	No		\$ 49,041	\$ -	\$ 2,942	24	25 Year
ULAR_700649_Block B Green Streets Program	ULAR	LASAN	City	Green Infrastructure	Distributed	Yes	Yes	No		\$ 1,092,920	\$ -	\$ 65,575	24	25 Year
ULAR_700849_Block B Green Streets Program	ULAR	LASAN	City	Green Infrastructure	Distributed	Yes	Yes	No		\$ 385,325	\$ -	\$ 23,119	24	25 Year
ULAR_602449_Block B Green Streets Program	ULAR	LASAN	City	Green Infrastructure	Distributed	Yes	Yes	No		\$ 6,102,139	\$ -	\$ 366,128	24	25 Year
ULAR_604049_Block B Green Streets Program	ULAR	LASAN	City	Green Infrastructure	Distributed	Yes	Yes	No		\$ 3,601,033	\$ -	\$ 216,062	24	25 Year
ULAR_604549_Block B Green Streets Program	ULAR	LASAN	City	Green Infrastructure	Distributed	Yes	Yes	No		\$ 3,404,867	\$ -	\$ 204,292	24	25 Year
ULAR_604649_Block B Green Streets Program	ULAR	LASAN	City	Green Infrastructure	Distributed	Yes	Yes	No		\$ 2,529,130	\$ -	\$ 151,748	24	25 Year
ULAR_604749_Block B Green Streets Program	ULAR	LASAN	City	Green Infrastructure	Distributed	Yes	Yes	No		\$ 3,888,275	\$ -	\$ 233,296	24	25 Year
ULAR_605049_Block B Green Streets Program	ULAR	LASAN	City	Green Infrastructure	Distributed	Yes	Yes	No		\$ 10,165,561	\$ -	\$ 609,934	24	25 Year
ULAR_605149_Block B Green Streets Program	ULAR	LASAN	City	Green Infrastructure	Distributed	Yes	Yes	No		\$ 2,115,782	\$ -	\$ 126,947	24	25 Year
ULAR_605249_Block B Green Streets Program	ULAR	LASAN	City	Green Infrastructure	Distributed	Yes	Yes	No		\$ 6,109,145	\$ -	\$ 366,549	24	25 Year
ULAR_605349_Block B Green Streets Program	ULAR	LASAN	City	Green Infrastructure	Distributed	Yes	Yes	No		\$ 4,470,433	\$ -	\$ 268,226	24	25 Year
ULAR_605449_Block B Green Streets Program	ULAR	LASAN	City	Green Infrastructure	Distributed	Yes	Yes	No		\$ 6,823,747	\$ -	\$ 409,425	24	25 Year
ULAR_605549_Block B Green Streets Program	ULAR	LASAN	City	Green Infrastructure	Distributed	Yes	Yes	No		\$ 10,207,596	\$ -	\$ 612,456	24	25 Year
ULAR_605649_Block B Green Streets Program	ULAR	LASAN	City	Green Infrastructure	Distributed	Yes	Yes	No		\$ 2,297,935	\$ -	\$ 137,876	24	25 Year
ULAR_605749_Block B Green Streets Program	ULAR	LASAN	City	Green Infrastructure	Distributed	Yes	Yes	No		\$ 10,198,237	\$ -	\$ 611,894	24	25 Year
ULAR_605949_Block B Green Streets Program	ULAR	LASAN	City	Green Infrastructure	Distributed	Yes	Yes	No		\$ 3,418,879	\$ -	\$ 205,133	24	25 Year
ULAR_606149_Block B Green Streets Program	ULAR	LASAN	City	Green Infrastructure	Distributed	Yes	Yes	No		\$ 3,516,962	\$ -	\$ 211,018	24	25 Year
ULAR_606249_Block B Green Streets Program	ULAR	LASAN	City	Green Infrastructure	Distributed	Yes	Yes	No		\$ 2,360,988	\$ -	\$ 141,659	24	25 Year
ULAR_637749_Block B Green Streets Program	ULAR	LASAN	City	Green Infrastructure	Distributed	Yes	Yes	No		\$ 7,888,643	\$ -	\$ 473,319	24	25 Year

Project Name	Watershed	Lead Agency	Project Type	Project Category	Project Size	Known Water Quality Benefit?	Known Water Supply Benefit?	Known Flood Risk Mitigation Benefit?	Other Considerations	Green Infrastructure Capital Cost	Grey Infrastructure Capital Cost	Annual O&M Cost	Selection Order	SIP Phase
ULAR_638349_Block B Green Streets Program	ULAR	LASAN	City	Green Infrastructure	Distributed	Yes	Yes	No		\$ 5,023,230	\$ -	\$ 301,394	24	25 Year
ULAR_638549_Block B Green Streets Program	ULAR	LASAN	City	Green Infrastructure	Distributed	Yes	Yes	No		\$ 7,237,095	\$ -	\$ 434,226	24	25 Year
ULAR_638849_Block B Green Streets Program	ULAR	LASAN	City	Green Infrastructure	Distributed	Yes	Yes	No		\$ 2,431,047	\$ -	\$ 145,863	24	25 Year
ULAR_639249_Block B Green Streets Program	ULAR	LASAN	City	Green Infrastructure	Distributed	Yes	Yes	No		\$ 2,269,912	\$ -	\$ 136,195	24	25 Year
ULAR_640249_Block B Green Streets Program	ULAR	LASAN	City	Green Infrastructure	Distributed	Yes	Yes	No		\$ 2,353,982	\$ -	\$ 141,239	24	25 Year
ULAR_640649_Block B Green Streets Program	ULAR	LASAN	City	Green Infrastructure	Distributed	Yes	Yes	No		\$ 3,117,626	\$ -	\$ 187,058	24	25 Year
ULAR_661949_Block B Green Streets Program	ULAR	LASAN	City	Green Infrastructure	Distributed	Yes	Yes	No		\$ 1,631,255	\$ -	\$ 97,875	24	25 Year
ULAR_662049_Block B Green Streets Program	ULAR	LASAN	City	Green Infrastructure	Distributed	Yes	Yes	No		\$ 589,266	\$ -	\$ 35,356	24	25 Year
ULAR_663949_Block B Green Streets Program	ULAR	LASAN	City	Green Infrastructure	Distributed	Yes	Yes	No		\$ 2,859,546	\$ -	\$ 171,573	24	25 Year
ULAR_664049_Block B Green Streets Program	ULAR	LASAN	City	Green Infrastructure	Distributed	Yes	Yes	No		\$ 2,375,000	\$ -	\$ 142,500	24	25 Year
ULAR_664149_Block B Green Streets Program	ULAR	LASAN	City	Green Infrastructure	Distributed	Yes	Yes	No		\$ 420,373	\$ -	\$ 25,222	24	25 Year
ULAR_664549_Block B Green Streets Program	ULAR	LASAN	City	Green Infrastructure	Distributed	Yes	Yes	No		\$ 1,612,052	\$ -	\$ 96,723	24	25 Year
ULAR_665049_Block B Green Streets Program	ULAR	LASAN	City	Green Infrastructure	Distributed	Yes	Yes	No		\$ 2,823,378	\$ -	\$ 169,403	24	25 Year
ULAR_667649_Block B Green Streets Program	ULAR	LASAN	City	Green Infrastructure	Distributed	Yes	Yes	No		\$ 11,952,065	\$ -	\$ 717,124	24	25 Year
ULAR_668749_Block B Green Streets Program	ULAR	LASAN	City	Green Infrastructure	Distributed	Yes	Yes	No		\$ 8,211,841	\$ -	\$ 492,710	24	25 Year
ULAR_683449_Block B Green Streets Program	ULAR	LASAN	City	Green Infrastructure	Distributed	Yes	Yes	No		\$ 2,662,242	\$ -	\$ 159,735	24	25 Year
ULAR_685649_Block B Green Streets Program	ULAR	LASAN	City	Green Infrastructure	Distributed	Yes	Yes	No		\$ 5,744,838	\$ -	\$ 344,690	24	25 Year
ULAR_689149_Block B Green Streets Program	ULAR	LASAN	City	Green Infrastructure	Distributed	Yes	Yes	No		\$ 2,494,100	\$ -	\$ 149,646	24	25 Year
ULAR_689249_Block B Green Streets Program	ULAR	LASAN	City	Green Infrastructure	Distributed	Yes	Yes	No		\$ 2,403,024	\$ -	\$ 144,181	24	25 Year
ULAR_691449_Block B Green Streets Program	ULAR	LASAN	City	Green Infrastructure	Distributed	Yes	Yes	No		\$ 1,577,736	\$ -	\$ 94,664	24	25 Year
ULAR_691949_Block B Green Streets Program	ULAR	LASAN	City	Green Infrastructure	Distributed	Yes	Yes	No		\$ 3,811,210	\$ -	\$ 228,673	24	25 Year
ULAR_692349_Block B Green Streets Program	ULAR	LASAN	City	Green Infrastructure	Distributed	Yes	Yes	No		\$ 5,212,390	\$ -	\$ 312,743	24	25 Year
ULAR_692549_Block B Green Streets Program	ULAR	LASAN	City	Green Infrastructure	Distributed	Yes	Yes	No		\$ 2,749,126	\$ -	\$ 164,948	24	25 Year
ULAR_692749_Block B Green Streets Program	ULAR	LASAN	City	Green Infrastructure	Distributed	Yes	Yes	No		\$ 4,658,924	\$ -	\$ 279,535	24	25 Year
ULAR_695649_Block B Green Streets Program	ULAR	LASAN	City	Green Infrastructure	Distributed	Yes	Yes	No		\$ 4,806,047	\$ -	\$ 288,363	24	25 Year
ULAR_695749_Block B Green Streets Program	ULAR	LASAN	City	Green Infrastructure	Distributed	Yes	Yes	No		\$ 4,890,118	\$ -	\$ 293,407	24	25 Year
ULAR_696049_Block B Green Streets Program	ULAR	LASAN	City	Green Infrastructure	Distributed	Yes	Yes	No		\$ 2,669,248	\$ -	\$ 160,155	24	25 Year
ULAR_697649_Block B Green Streets Program	ULAR	LASAN	City	Green Infrastructure	Distributed	Yes	Yes	No		\$ 6,424,410	\$ -	\$ 385,465	24	25 Year
ULAR_697749_Block B Green Streets Program	ULAR	LASAN	City	Green Infrastructure	Distributed	Yes	Yes	No		\$ 2,199,853	\$ -	\$ 131,991	24	25 Year
ULAR_697849_Block B Green Streets Program	ULAR	LASAN	City	Green Infrastructure	Distributed	Yes	Yes	No		\$ 2,543,142	\$ -	\$ 152,589	24	25 Year
ULAR_697949_Block B Green Streets Program	ULAR	LASAN	City	Green Infrastructure	Distributed	Yes	Yes	No		\$ 4,217,552	\$ -	\$ 253,053	24	25 Year
ULAR_699449_Block B Green Streets Program	ULAR	LASAN	City	Green Infrastructure	Distributed	Yes	Yes	No		\$ 2,396,018	\$ -	\$ 143,761	24	25 Year
ULAR_699549_Block B Green Streets Program	ULAR	LASAN	City	Green Infrastructure	Distributed	Yes	Yes	No		\$ 3,348,820	\$ -	\$ 200,929	24	25 Year
ULAR_699949_Block B Green Streets Program	ULAR	LASAN	City	Green Infrastructure	Distributed	Yes	Yes	No		\$ 2,886,431	\$ -	\$ 173,186	24	25 Year
LA River Sixth Street Bridge Greenway	ULAR	LABOE	City	Green Infrastructure	Distributed	Yes	Yes	No	Community Beautification	\$ 30,000,000	\$ -	\$ 100,000	25	25 Year
Big Tujunga Reservoir Sediment Removal	ULAR	LACFCD/ LADWP	Partner	Green Infrastructure	Centralized	No	Yes	Yes	Funding - LADWP	\$ 24,000,000	\$ -	\$ -	26	25 Year
Haddon Avenue Elementary School	ULAR	LAUSD/LADWP	Partner	Green Infrastructure	Centralized	Yes	Yes	No		\$ 100,000	\$ -	\$ 5,000	27	25 Year
Liggett Street Elementary School	ULAR	LAUSD/LADWP	Partner	Green Infrastructure	Centralized	Yes	Yes	No		\$ 100,000	\$ -	\$ 5,000	27	25 Year
Noble Avenue Elementary School	ULAR	LAUSD/LADWP	Partner	Green Infrastructure	Centralized	Yes	Yes	No		\$ 100,000	\$ -	\$ 5,000	27	25 Year
San Jose Elementary School	ULAR	LAUSD/LADWP	Partner	Green Infrastructure	Centralized	Yes	Yes	No		\$ 100,000	\$ -	\$ 5,000	27	25 Year
Silver Lake Reservoir Bypass & Regulator Station	ULAR	LADWP	City	Green Infrastructure	Centralized	Yes	Yes	No		\$ 52,160,000	\$ -	\$ 500,000	27	25 Year
Telfair Elementary School	ULAR	LAUSD/LADWP	Partner	Green Infrastructure	Centralized	Yes	Yes	No		\$ 100,000	\$ -	\$ 5,000	27	25 Year
Victory Boulevard Elementary School	ULAR	LAUSD/LADWP	Partner	Green Infrastructure	Centralized	Yes	Yes	No		\$ 100,000	\$ -	\$ 5,000	27	25 Year
Coldwater Canyon Ave. Pocket Park & Parkway Infiltration Demonstration	ULAR	LA Mayor's Office/LADWP	City	Green Infrastructure	Distributed	Yes	Yes	No		\$ 3,000,000	\$ -	\$ 180,000	28	25 Year
Bull Creek Water Conservation (Pipeline)	ULAR	LACFCD/ LADWP	Partner	Green Infrastructure	Centralized	No	Yes	No		\$ 10,610,000	\$ -	\$ 50,000	29	25 Year
112th St - Hooper Ave to 114th St SD	ULAR	LABOE	City	Grey Infrastructure	Stormwater Conveyance	No	No	Yes		\$ -	\$ 1,085,900	\$ 54,295	30	25 Year
12th St & Los Angeles St	ULAR	LABOE	City	Grey Infrastructure	Stormwater Conveyance	No	No	Yes		\$ -	\$ 67,000	\$ 3,350	30	25 Year
12th Street / Santee Street Relief Storm Drain	ULAR	LABOE	City	Grey Infrastructure	Stormwater Conveyance	No	No	Yes		\$ -	\$ 796,500	\$ 39,825	30	25 Year
1477 Montecito Drive Stormdrain	ULAR	LABOE	City	Grey Infrastructure	Stormwater Conveyance	No	No	Yes		\$ -	\$ 145,900	\$ 7,295	30	25 Year
18th Street & Walker Avenue	DC	LABOE	City	Grey Infrastructure	Stormwater Conveyance	No	No	Yes		\$ -	\$ 2,137,800	\$ 106,890	30	25 Year
19th Street, Alma Street and 21st Street Storm Drain	DC	LABOE	City	Grey Infrastructure	Stormwater Conveyance	No	No	Yes		\$ -	\$ 1,632,700	\$ 81,635	30	25 Year
200 foot Esmt N/O Hillrose Btwn Irma & Plainview	ULAR	LABOE	City	Grey Infrastructure	Stormwater Conveyance	No	No	Yes		\$ -	\$ 137,500	\$ 6,875	30	25 Year
364 S Anderson St (X Artemus Street)	ULAR	LABOE	City	Grey Infrastructure	Stormwater Conveyance	No	No	Yes		\$ -	\$ 24,400	\$ 1,220	30	25 Year
486 W Avenue 44	ULAR	LABOE	City	Grey Infrastructure	Stormwater Conveyance	No	No	Yes		\$ -	\$ 154,700	\$ 7,735	30	25 Year
4th Street and Main Street	ULAR	LABOE	City	Grey Infrastructure	Stormwater Conveyance	No	No	Yes		\$ -	\$ 54,300	\$ 2,715	30	25 Year
6245 Roy Street Storm Drain	ULAR	LABOE	City	Grey Infrastructure	Stormwater Conveyance	No	No	Yes		\$ -	\$ 162,900	\$ 8,145	30	25 Year
Agnes Vanowen SD	ULAR	LABOE	City	Grey Infrastructure	Stormwater Conveyance	No	No	Yes		\$ -	\$ 3,017,000	\$ 150,850	30	25 Year
Amestoy - Prairie To Parthenia	ULAR	LABOE	City	Grey Infrastructure	Stormwater Conveyance	No	No	Yes		\$ -	\$ 3,959,900	\$ 197,995	30	25 Year
Amigo And Vanowen	ULAR	LABOE	City	Grey Infrastructure	Stormwater Conveyance	No	No	Yes		\$ -	\$ 1,484,900	\$ 74,245	30	25 Year
Balboa Bl SD Extension To Lassen	ULAR	LABOE	City	Grey Infrastructure	Stormwater Conveyance	No	No	Yes		\$ -	\$ 1,752,700	\$ 87,635	30	25 Year
Bandini Street - Summerland Ave to Oliver St	DC	LABOE	City	Grey Infrastructure	Stormwater Conveyance	No	No	Yes		\$ -	\$ 414,300	\$ 20,715	30	25 Year
Bartee Avenue - Kagel To Osborne	ULAR	LABOE	City	Grey Infrastructure	Stormwater Conveyance	No	No	Yes		\$ -	\$ 997,000	\$ 49,850	30	25 Year
Beck Avenue - Hamlin Street SD	ULAR	LABOE	City	Grey Infrastructure	Stormwater Conveyance	No	No	Yes		\$ -	\$ 1,353,400	\$ 67,670	30	25 Year
Bellaire Av - Albers To Collins	ULAR	LABOE	City	Grey Infrastructure	Stormwater Conveyance	No	No	Yes		\$ -	\$ 1,222,400	\$ 61,120	30	25 Year
Benedict Canyon Ln S/O Ventura Bl	ULAR	LABOE	City	Grey Infrastructure	Stormwater Conveyance	No	No	Yes		\$ -	\$ 3,405,300	\$ 170,265	30	25 Year
Berry Dr and Decente Dr SD	ULAR	LABOE	City	Grey Infrastructure	Stormwater Conveyance	No	No	Yes		\$ -	\$ 197,500	\$ 9,875	30	25 Year
Berry Dr E/O Laurel Cyn Bl	ULAR	LABOE	City	Grey Infrastructure	Stormwater Conveyance	No	No	Yes		\$ -	\$ 1,340,800	\$ 67,400	30	25 Year
Bessemer Street SD - Alcove Ave to Tujunga Wash Ch	ULAR	LABOE	City	Grey Infrastructure	Stormwater Conveyance	No	No	Yes		\$ -	\$ 471,500	\$ 23,575	30	25 Year

Project Name	Watershed	Lead Agency	Project Type	Project Category	Project Size	Known Water Quality Benefit?	Known Water Supply Benefit ?	Known Flood Risk Mitigation Benefit?	Other Considerations	Green Infrastructure Capital Cost	Grey Infrastructure Capital Cost	Annual O&M Cost	Selection Order	SIP Phase
Beverly Glen SD	ULAR	LABOE	City	Grey Infrastructure	Stormwater Conveyance	No	No	Yes		\$ -	\$ 5,363,300	\$ 268,165	30	25 Year
Big Tujunga Wash Levee at Oro Vista Avenue	ULAR	LABOE	City	Grey Infrastructure	Stormwater Conveyance	No	No	Yes		\$ -	\$ 814,400	\$ 40,720	30	25 Year
Blanchard Cyn Ch 900 N/E to Fern Cyn Trl	ULAR	LABOE	City	Grey Infrastructure	Stormwater Conveyance	No	No	Yes		\$ -	\$ 1,004,100	\$ 50,205	30	25 Year
Bradley Del Sur SD	ULAR	LABOE	City	Grey Infrastructure	Stormwater Conveyance	No	No	Yes		\$ -	\$ 3,677,000	\$ 183,850	30	25 Year
Branford - Canterbury to Dorrington	ULAR	LABOE	City	Grey Infrastructure	Stormwater Conveyance	No	No	Yes		\$ -	\$ 1,178,700	\$ 58,935	30	25 Year
Branford - Glenoaks Bl To San Fernando	ULAR	LABOE	City	Grey Infrastructure	Stormwater Conveyance	No	No	Yes		\$ -	\$ 3,318,000	\$ 165,900	30	25 Year
Branford - Laurel Canyon To Arleta Avenue (aka	ULAR	LABOE	City	Grey Infrastructure	Stormwater Conveyance	No	No	Yes		\$ -	\$ 2,619,400	\$ 130,970	30	25 Year
Branford Street - Arleta Avenue to the Pacoima Wash	ULAR	LABOE	City	Grey Infrastructure	Stormwater Conveyance	No	No	Yes		\$ -	\$ 632,800	\$ 31,640	30	25 Year
Brookdale Rd and Fryman Rd	ULAR	LABOE	City	Grey Infrastructure	Stormwater Conveyance	No	No	Yes		\$ -	\$ 1,135,100	\$ 56,755	30	25 Year
Brooktree Low Flow	SMB	LABOE	City	Grey Infrastructure	Stormwater Conveyance	No	No	Yes		\$ -	\$ 609,800	\$ 30,490	30	25 Year
Burbank Bl - Hollywood Fwy to Gentry	ULAR	LABOE	City	Grey Infrastructure	Stormwater Conveyance	No	No	Yes		\$ -	\$ 852,400	\$ 42,620	30	25 Year
Burbank Bl & Farralona Av SD	ULAR	LABOE	City	Grey Infrastructure	Stormwater Conveyance	No	No	Yes		\$ -	\$ 1,004,100	\$ 50,205	30	25 Year
Burbank Boulevard - 1,850 feet W/O Hayvenhurst Ave	ULAR	LABOE	City	Grey Infrastructure	Stormwater Conveyance	No	No	Yes		\$ -	\$ 374,200	\$ 18,710	30	25 Year
Burbank Boulevard SD - Biloxi Ave to Cahuenga Blvd	ULAR	LABOE	City	Grey Infrastructure	Stormwater Conveyance	No	No	Yes		\$ -	\$ 2,785,800	\$ 139,290	30	25 Year
Camarillo And Vineland SD	ULAR	LABOE	City	Grey Infrastructure	Stormwater Conveyance	No	No	Yes		\$ -	\$ 3,205,600	\$ 160,280	30	25 Year
Camarillo St - Halbrent to Kester	ULAR	LABOE	City	Grey Infrastructure	Stormwater Conveyance	No	No	Yes		\$ -	\$ 1,829,500	\$ 91,475	30	25 Year
Camino de la Cumbre SD	ULAR	LABOE	City	Grey Infrastructure	Stormwater Conveyance	No	No	Yes		\$ -	\$ 1,622,800	\$ 81,140	30	25 Year
Canoga Roscoe SD	ULAR	LABOE	City	Grey Infrastructure	Stormwater Conveyance	No	No	Yes		\$ -	\$ 5,657,000	\$ 282,850	30	25 Year
Canterbury Av & Pierce St	ULAR	LABOE	City	Grey Infrastructure	Stormwater Conveyance	No	No	Yes		\$ -	\$ 3,323,400	\$ 166,170	30	25 Year
Chandler And Tyrone SD	ULAR	LABOE	City	Grey Infrastructure	Stormwater Conveyance	No	No	Yes		\$ -	\$ 1,663,100	\$ 83,155	30	25 Year
Chase Mason SD	ULAR	LABOE	City	Grey Infrastructure	Stormwater Conveyance	No	No	Yes		\$ -	\$ 2,039,900	\$ 101,995	30	25 Year
Chautauqua Blvd Storm Drain	SMB	LABOE	City	Grey Infrastructure	Stormwater Conveyance	No	No	Yes		\$ -	\$ 2,155,000	\$ 107,750	30	25 Year
City Hall Main Street Storm Drain	ULAR	LABOE	City	Grey Infrastructure	Stormwater Conveyance	No	No	Yes		\$ -	\$ 359,200	\$ 17,960	30	25 Year
Clybourn Av - Vanowen To Victory	ULAR	LABOE	City	Grey Infrastructure	Stormwater Conveyance	No	No	Yes		\$ -	\$ 6,902,000	\$ 345,100	30	25 Year
Coldwater Canyon SD - Landale St to LA River	ULAR	LABOE	City	Grey Infrastructure	Stormwater Conveyance	No	No	Yes		\$ -	\$ 2,357,100	\$ 117,855	30	25 Year
Coldwater Cyn Ave & Goodland Ave S/O Ventura	ULAR	LABOE	City	Grey Infrastructure	Stormwater Conveyance	No	No	Yes		\$ -	\$ 7,966,900	\$ 398,345	30	25 Year
Colfax Magnolia SD	ULAR	LABOE	City	Grey Infrastructure	Stormwater Conveyance	No	No	Yes		\$ -	\$ 309,400	\$ 15,470	30	25 Year
Colfax, Riverside to L.A. River	ULAR	LABOE	City	Grey Infrastructure	Stormwater Conveyance	No	No	Yes		\$ -	\$ 5,751,200	\$ 287,560	30	25 Year
Collier Street SD - E/O Quakertown Ave to Winnetka	ULAR	LABOE	City	Grey Infrastructure	Stormwater Conveyance	No	No	Yes		\$ -	\$ 415,800	\$ 20,790	30	25 Year
Commerce Valmont SD	ULAR	LABOE	City	Grey Infrastructure	Stormwater Conveyance	No	No	Yes		\$ -	\$ 1,225,700	\$ 61,285	30	25 Year
Compton Avenue - 55th Street SD	ULAR	LABOE	City	Grey Infrastructure	Stormwater Conveyance	No	No	Yes		\$ -	\$ 507,700	\$ 25,385	30	25 Year
Corbin Channel - L.A. River To S.P.R.R.	ULAR	LABOE	City	Grey Infrastructure	Stormwater Conveyance	No	No	Yes		\$ -	\$ 3,596,500	\$ 179,825	30	25 Year
Craig Drive & R/W S/O Hillock Drive SD	ULAR	LABOE	City	Grey Infrastructure	Stormwater Conveyance	No	No	Yes		\$ -	\$ 327,400	\$ 16,370	30	25 Year
Cross Ave - Eldred St Storm Drain Project	ULAR	LABOE	City	Grey Infrastructure	Stormwater Conveyance	No	No	Yes		\$ -	\$ 620,500	\$ 31,025	30	25 Year
D Street & Neptune Avenue	DC	LABOE	City	Grey Infrastructure	Stormwater Conveyance	No	No	Yes		\$ -	\$ 3,521,900	\$ 176,095	30	25 Year
Del Arroyo to La Tuna Cyn Chnl	ULAR	LABOE	City	Grey Infrastructure	Stormwater Conveyance	No	No	Yes		\$ -	\$ 1,925,300	\$ 96,265	30	25 Year
Devonshire Owensmouth SD	ULAR	LABOE	City	Grey Infrastructure	Stormwater Conveyance	No	No	Yes		\$ -	\$ 752,500	\$ 37,625	30	25 Year
Dixie Cyn Ave S/O Valley Vista	ULAR	LABOE	City	Grey Infrastructure	Stormwater Conveyance	No	No	Yes		\$ -	\$ 4,157,900	\$ 207,895	30	25 Year
Dorris Place SD	ULAR	LABOE	City	Grey Infrastructure	Stormwater Conveyance	No	No	Yes		\$ -	\$ 1,402,700	\$ 70,135	30	25 Year
Ebey Cyn - W/O Riverwood Rd	ULAR	LABOE	City	Grey Infrastructure	Stormwater Conveyance	No	No	Yes		\$ -	\$ 2,177,900	\$ 108,895	30	25 Year
Encinitas Avenue - Cobalt St to Bledsoe St	ULAR	LABOE	City	Grey Infrastructure	Stormwater Conveyance	No	No	Yes		\$ -	\$ 1,292,700	\$ 64,635	30	25 Year
Erwin St - Goodland Av-Victory Bl-Hamlin St	ULAR	LABOE	City	Grey Infrastructure	Stormwater Conveyance	No	No	Yes		\$ -	\$ 4,949,800	\$ 247,490	30	25 Year
Ethel Av - Raymer To Sherman Way	ULAR	LABOE	City	Grey Infrastructure	Stormwater Conveyance	No	No	Yes		\$ -	\$ 1,045,200	\$ 52,260	30	25 Year
Fair Avenue (Prod.) SD - Alley S/O Hesby St to Morrison	ULAR	LABOE	City	Grey Infrastructure	Stormwater Conveyance	No	No	Yes		\$ -	\$ 166,300	\$ 8,315	30	25 Year
Farralona Av - Gault To Leadwell	ULAR	LABOE	City	Grey Infrastructure	Stormwater Conveyance	No	No	Yes		\$ -	\$ 1,732,400	\$ 86,620	30	25 Year
Farralona Av - Saticoy to Keswick	ULAR	LABOE	City	Grey Infrastructure	Stormwater Conveyance	No	No	Yes		\$ -	\$ 693,000	\$ 34,650	30	25 Year
Fenwick Sable SD	ULAR	LABOE	City	Grey Infrastructure	Stormwater Conveyance	No	No	Yes		\$ -	\$ 377,100	\$ 18,855	30	25 Year
Filmore St - Foothill To Dronfield	ULAR	LABOE	City	Grey Infrastructure	Stormwater Conveyance	No	No	Yes		\$ -	\$ 2,029,400	\$ 101,470	30	25 Year
Filmore Street SD - Lev Ave to Pacoima Wash	ULAR	LABOE	City	Grey Infrastructure	Stormwater Conveyance	No	No	Yes		\$ -	\$ 748,400	\$ 37,420	30	25 Year
Foothill (R/W S/O) Whitegate To Leolang	ULAR	LABOE	City	Grey Infrastructure	Stormwater Conveyance	No	No	Yes		\$ -	\$ 165,900	\$ 8,295	30	25 Year
Foothill Bl - Haines Cyn Ch to Haines Cyn Ave	ULAR	LABOE	City	Grey Infrastructure	Stormwater Conveyance	No	No	Yes		\$ -	\$ 1,435,400	\$ 71,770	30	25 Year
Foothill SD-Pacoima Cyn Chl To Sump S/O Maclay	ULAR	LABOE	City	Grey Infrastructure	Stormwater Conveyance	No	No	Yes		\$ -	\$ 612,800	\$ 30,640	30	25 Year
Foothill Vaughn SD	ULAR	LABOE	City	Grey Infrastructure	Stormwater Conveyance	No	No	Yes		\$ -	\$ 2,619,400	\$ 130,970	30	25 Year
Foothill -Wheatland To 400 feet E/O	ULAR	LABOE	City	Grey Infrastructure	Stormwater Conveyance	No	No	Yes		\$ -	\$ 458,400	\$ 22,920	30	25 Year
Forman Drain N/O Burbank To Sherman Way (covered	ULAR	LABOE	City	Grey Infrastructure	Stormwater Conveyance	No	No	Yes		\$ -	\$ 12,822,400	\$ 641,120	30	25 Year
Fries Avenue SD - Unit 3	DC	LABOE	City	Grey Infrastructure	Stormwater Conveyance	No	No	Yes		\$ -	\$ 3,469,200	\$ 173,460	30	25 Year
Fulton Av - Sherman Way To Raymer	ULAR	LABOE	City	Grey Infrastructure	Stormwater Conveyance	No	No	Yes		\$ -	\$ 1,265,200	\$ 63,260	30	25 Year
Fulton Av - Victory To Kittridge	ULAR	LABOE	City	Grey Infrastructure	Stormwater Conveyance	No	No	Yes		\$ -	\$ 1,225,700	\$ 61,285	30	25 Year
Fulton Av L A River To 150 feet S/O Ventura Bl	ULAR	LABOE	City	Grey Infrastructure	Stormwater Conveyance	No	No	Yes		\$ -	\$ 1,188,000	\$ 59,400	30	25 Year
Gault Haskell to 700' W/O Haskell	ULAR	LABOE	City	Grey Infrastructure	Stormwater Conveyance	No	No	Yes		\$ -	\$ 612,800	\$ 30,640	30	25 Year
Gladstone Maclay	ULAR	LABOE	City	Grey Infrastructure	Stormwater Conveyance	No	No	Yes		\$ -	\$ 1,091,400	\$ 54,570	30	25 Year
Glenoaks Bl-Cobalt To Tyler St	ULAR	LABOE	City	Grey Infrastructure	Stormwater Conveyance	No	No	Yes		\$ -	\$ 5,845,500	\$ 292,275	30	25 Year
Glenoaks Filmore SD	ULAR	LABOE	City	Grey Infrastructure	Stormwater Conveyance	No	No	Yes		\$ -	\$ 1,833,600	\$ 91,680	30	25 Year
Gloria Av - Saticoy To Arminta	ULAR	LABOE	City	Grey Infrastructure	Stormwater Conveyance	No	No	Yes		\$ -	\$ 1,375,200	\$ 68,760	30	25 Year
Grove St R/W S/O- Scoville To Oro Vista	ULAR	LABOE	City	Grey Infrastructure	Stormwater Conveyance	No	No	Yes		\$ -	\$ 518,600	\$ 25,930	30	25 Year
Gulf Avenue & D Street	DC	LABOE	City	Grey Infrastructure	Stormwater Conveyance	No	No	Yes		\$ -	\$ 2,469,100	\$ 123,455	30	25 Year
Haddon Av - Tuxford To Rialto	ULAR	LABOE	City	Grey Infrastructure	Stormwater Conveyance	No	No	Yes		\$ -	\$ 1,168,900	\$ 58,445	30	25 Year
Hartland St - Comanche To Oso	ULAR	LABOE	City	Grey Infrastructure	Stormwater Conveyance	No	No	Yes		\$ -	\$ 1,231,400	\$ 61,570	30	25 Year
Haskell Avenue SD - Los Alimos St to San Jose St	ULAR	LABOE	City	Grey Infrastructure	Stormwater Conveyance	No	No	Yes		\$ -	\$ 1,663,100	\$ 83,155	30	25 Year

Project Name	Watershed	Lead Agency	Project Type	Project Category	Project Size	Known Water Quality Benefit?	Known Water Supply Benefit?	Known Flood Risk Mitigation Benefit?	Other Considerations	Green Infrastructure Capital Cost	Grey Infrastructure Capital Cost	Annual O&M Cost	Selection Order	SIP Phase
Haskell Parthenia SD	ULAR	LABOE	City	Grey Infrastructure	Stormwater Conveyance	No	No	Yes		\$ -	\$ 2,244,800	\$ 112,240	30	25 Year
Hatteras St - Whitnall To Cleon	ULAR	LABOE	City	Grey Infrastructure	Stormwater Conveyance	No	No	Yes		\$ -	\$ 1,795,900	\$ 89,795	30	25 Year
Hawaiian and Opp Storm Drain	DC	LABOE	City	Grey Infrastructure	Stormwater Conveyance	No	No	Yes		\$ -	\$ 1,433,400	\$ 71,670	30	25 Year
Haynes Street SD - Woodlake Ave to Berquest Ave	ULAR	LABOE	City	Grey Infrastructure	Stormwater Conveyance	No	No	Yes		\$ -	\$ 790,000	\$ 39,500	30	25 Year
Hayvenhurst Av and Calneva Dr	ULAR	LABOE	City	Grey Infrastructure	Stormwater Conveyance	No	No	Yes		\$ -	\$ 2,639,900	\$ 131,995	30	25 Year
Hayvenhurst(Chnl W/O)-S/O Ventura To De Celis	ULAR	LABOE	City	Grey Infrastructure	Stormwater Conveyance	No	No	Yes		\$ -	\$ 435,500	\$ 21,775	30	25 Year
Hazeltine Av - Cohasset To Sherman Way	ULAR	LABOE	City	Grey Infrastructure	Stormwater Conveyance	No	No	Yes		\$ -	\$ 1,457,700	\$ 72,885	30	25 Year
Helen Avenue - Art Street SD	ULAR	LABOE	City	Grey Infrastructure	Stormwater Conveyance	No	No	Yes		\$ -	\$ 1,131,400	\$ 56,570	30	25 Year
Hidden Oak Apperson SD	ULAR	LABOE	City	Grey Infrastructure	Stormwater Conveyance	No	No	Yes		\$ -	\$ 230,800	\$ 11,540	30	25 Year
Hubbard and Dronfield	ULAR	LABOE	City	Grey Infrastructure	Stormwater Conveyance	No	No	Yes		\$ -	\$ 503,600	\$ 25,180	30	25 Year
Kagel Canyon - Remick To Pacoima Wash	ULAR	LABOE	City	Grey Infrastructure	Stormwater Conveyance	No	No	Yes		\$ -	\$ 1,615,900	\$ 80,795	30	25 Year
Kittridge St - Satsuma To Clybourn	ULAR	LABOE	City	Grey Infrastructure	Stormwater Conveyance	No	No	Yes		\$ -	\$ 687,600	\$ 34,380	30	25 Year
Knobhill - 100 feet To 300 feet E/O Beverly Glen	ULAR	LABOE	City	Grey Infrastructure	Stormwater Conveyance	No	No	Yes		\$ -	\$ 171,900	\$ 8,595	30	25 Year
Knollwood Dr and Clonlee Av SD	ULAR	LABOE	City	Grey Infrastructure	Stormwater Conveyance	No	No	Yes		\$ -	\$ 249,500	\$ 12,475	30	25 Year
La Tuna Cyn Rd Drainage Chan. Reconstruction	ULAR	LABOE	City	Grey Infrastructure	Stormwater Conveyance	No	No	Yes		\$ -	\$ 401,600	\$ 20,080	30	25 Year
Lambie Street SD	ULAR	LABOE	City	Grey Infrastructure	Stormwater Conveyance	No	No	Yes		\$ -	\$ 578,700	\$ 28,935	30	25 Year
Lanark E/O Hazeltine S.D.	ULAR	LABOE	City	Grey Infrastructure	Stormwater Conveyance	No	No	Yes		\$ -	\$ 1,781,900	\$ 89,095	30	25 Year
Lanark St - Willis To Cedros	ULAR	LABOE	City	Grey Infrastructure	Stormwater Conveyance	No	No	Yes		\$ -	\$ 385,100	\$ 19,255	30	25 Year
Lankershim Boulevard - Bloomfield Street SD	ULAR	LABOE	City	Grey Infrastructure	Stormwater Conveyance	No	No	Yes		\$ -	\$ 2,262,800	\$ 113,140	30	25 Year
Lankershim Boulevard SD - Sherman Way to Tuxford St	ULAR	LABOE	City	Grey Infrastructure	Stormwater Conveyance	No	No	Yes		\$ -	\$ 8,674,000	\$ 433,700	30	25 Year
Lasaine Avenue (Produced) Oxnard Street to LA River	ULAR	LABOE	City	Grey Infrastructure	Stormwater Conveyance	No	No	Yes		\$ -	\$ 1,725,500	\$ 86,275	30	25 Year
Lasaine Oxnard SD	ULAR	LABOE	City	Grey Infrastructure	Stormwater Conveyance	No	No	Yes		\$ -	\$ 2,027,100	\$ 101,355	30	25 Year
Lassen St - Lindley Av To Aliso Creek SD	ULAR	LABOE	City	Grey Infrastructure	Stormwater Conveyance	No	No	Yes		\$ -	\$ 1,770,400	\$ 88,520	30	25 Year
Lassen St Topanga Cyn Bl To Owensmouth	ULAR	LABOE	City	Grey Infrastructure	Stormwater Conveyance	No	No	Yes		\$ -	\$ 282,500	\$ 14,125	30	25 Year
Laurel Cyn Bl N/O Riverside Dr	ULAR	LABOE	City	Grey Infrastructure	Stormwater Conveyance	No	No	Yes		\$ -	\$ 2,200,300	\$ 110,015	30	25 Year
Laurelgrove Av - Magnolia To Riverside Dr	ULAR	LABOE	City	Grey Infrastructure	Stormwater Conveyance	No	No	Yes		\$ -	\$ 1,072,700	\$ 53,635	30	25 Year
Libbit Av & Morrison St	ULAR	LABOE	City	Grey Infrastructure	Stormwater Conveyance	No	No	Yes		\$ -	\$ 2,062,800	\$ 103,140	30	25 Year
Louise - Nordhoff To SPRR	ULAR	LABOE	City	Grey Infrastructure	Stormwater Conveyance	No	No	Yes		\$ -	\$ 4,979,900	\$ 248,995	30	25 Year
Louise Silverlane (Pvt St S/O 101) To Magnolia	ULAR	LABOE	City	Grey Infrastructure	Stormwater Conveyance	No	No	Yes		\$ -	\$ 1,210,200	\$ 60,510	30	25 Year
Lowell Av - Santa Carlotta To Cooks Chnl	ULAR	LABOE	City	Grey Infrastructure	Stormwater Conveyance	No	No	Yes		\$ -	\$ 1,430,200	\$ 71,510	30	25 Year
Lurline Av-Rinaldi To Devonshire	ULAR	LABOE	City	Grey Infrastructure	Stormwater Conveyance	No	No	Yes		\$ -	\$ 3,334,900	\$ 166,745	30	25 Year
Maclay SD - Bromont to 8th St	ULAR	LABOE	City	Grey Infrastructure	Stormwater Conveyance	No	No	Yes		\$ -	\$ 835,800	\$ 41,790	30	25 Year
Magnolia Boulevard - Densmore Ave to Gaviota Ave	ULAR	LABOE	City	Grey Infrastructure	Stormwater Conveyance	No	No	Yes		\$ -	\$ 582,200	\$ 29,110	30	25 Year
Magnolia Boulevard - Ranchito Ave to Hazeltine Ave SD	ULAR	LABOE	City	Grey Infrastructure	Stormwater Conveyance	No	No	Yes		\$ -	\$ 1,164,200	\$ 58,210	30	25 Year
Marcus Ln And Estaban St	ULAR	LABOE	City	Grey Infrastructure	Stormwater Conveyance	No	No	Yes		\$ -	\$ 1,744,200	\$ 87,210	30	25 Year
Mariano St - Manton To Calabasas Creek	ULAR	LABOE	City	Grey Infrastructure	Stormwater Conveyance	No	No	Yes		\$ -	\$ 1,375,200	\$ 68,760	30	25 Year
Mariano St SD - Sadring to Calabasas Creek	ULAR	LABOE	City	Grey Infrastructure	Stormwater Conveyance	No	No	Yes		\$ -	\$ 283,800	\$ 14,190	30	25 Year
Marnice Av @ Haywood St	ULAR	LABOE	City	Grey Infrastructure	Stormwater Conveyance	No	No	Yes		\$ -	\$ 68,800	\$ 3,440	30	25 Year
Matilija Av - L.A. River-Woodman Av SD	ULAR	LABOE	City	Grey Infrastructure	Stormwater Conveyance	No	No	Yes		\$ -	\$ 9,626,500	\$ 481,325	30	25 Year
Matilija Av And Milbank St SD	ULAR	LABOE	City	Grey Infrastructure	Stormwater Conveyance	No	No	Yes		\$ -	\$ 659,200	\$ 32,960	30	25 Year
McKinley Avenue SD - 103rd St to 108th St	ULAR	LABOE	City	Grey Infrastructure	Stormwater Conveyance	No	No	Yes		\$ -	\$ 3,059,900	\$ 152,995	30	25 Year
Mcvine Av - Day To Haines Cyn Chnl	ULAR	LABOE	City	Grey Infrastructure	Stormwater Conveyance	No	No	Yes		\$ -	\$ 1,583,900	\$ 79,195	30	25 Year
Mission Road SD - Lincoln Park Ave to Thomas St	ULAR	LABOE	City	Grey Infrastructure	Stormwater Conveyance	No	No	Yes		\$ -	\$ 846,500	\$ 42,325	30	25 Year
Montague Street SD - Canterbury Ave to Gullo Ave	ULAR	LABOE	City	Grey Infrastructure	Stormwater Conveyance	No	No	Yes		\$ -	\$ 706,800	\$ 35,340	30	25 Year
Montague Street SD - Sharp Ave to Pacoima Wash	ULAR	LABOE	City	Grey Infrastructure	Stormwater Conveyance	No	No	Yes		\$ -	\$ 611,200	\$ 30,560	30	25 Year
Montecito Drive to Latrobe Street Storm Drain	ULAR	LABOE	City	Grey Infrastructure	Stormwater Conveyance	No	No	Yes		\$ -	\$ 176,400	\$ 8,820	30	25 Year
Montgomery Av - Blackhawk To Devonshire	ULAR	LABOE	City	Grey Infrastructure	Stormwater Conveyance	No	No	Yes		\$ -	\$ 286,500	\$ 14,325	30	25 Year
Moorpark St & Sunnyslope Av SD	ULAR	LABOE	City	Grey Infrastructure	Stormwater Conveyance	No	No	Yes		\$ -	\$ 1,655,000	\$ 82,750	30	25 Year
Moorpark Street & Agnes Avenue SD	ULAR	LABOE	City	Grey Infrastructure	Stormwater Conveyance	No	No	Yes		\$ -	\$ 2,907,600	\$ 145,380	30	25 Year
Moorpark Tujunga SD	ULAR	LABOE	City	Grey Infrastructure	Stormwater Conveyance	No	No	Yes		\$ -	\$ 1,706,900	\$ 85,345	30	25 Year
Mulholland Drive - Topanga Cyn Blvd to Canoga Ave	ULAR	LABOE	City	Grey Infrastructure	Stormwater Conveyance	No	No	Yes		\$ -	\$ 2,553,100	\$ 127,655	30	25 Year
N/O Ellenbogen - 150 feet W/O Parr Av	ULAR	LABOE	City	Grey Infrastructure	Stormwater Conveyance	No	No	Yes		\$ -	\$ 302,500	\$ 15,125	30	25 Year
Neptune Avenue & G Street SD	DC	LABOE	City	Grey Infrastructure	Stormwater Conveyance	No	No	Yes		\$ -	\$ 3,622,300	\$ 181,115	30	25 Year
Nordhoff Street SD - Bahama Cyn to Lurline Ave	ULAR	LABOE	City	Grey Infrastructure	Stormwater Conveyance	No	No	Yes		\$ -	\$ 914,000	\$ 45,700	30	25 Year
Nordhoff Street SD - Sepulveda Blvd to Orion Ave	ULAR	LABOE	City	Grey Infrastructure	Stormwater Conveyance	No	No	Yes		\$ -	\$ 607,800	\$ 30,390	30	25 Year
Opp Street SD Replacement	DC	LABOE	City	Grey Infrastructure	Stormwater Conveyance	No	No	Yes		\$ -	\$ 162,500	\$ 8,125	30	25 Year
Orion Parthenia SD	ULAR	LABOE	City	Grey Infrastructure	Stormwater Conveyance	No	No	Yes		\$ -	\$ 7,165,500	\$ 358,275	30	25 Year
Orion St - Wyandotte To Stagg	ULAR	LABOE	City	Grey Infrastructure	Stormwater Conveyance	No	No	Yes		\$ -	\$ 2,269,100	\$ 113,455	30	25 Year
Oro Vista SD - Haines Canyon Channel to Foothill Blvd	ULAR	LABOE	City	Grey Infrastructure	Stormwater Conveyance	No	No	Yes		\$ -	\$ 2,061,700	\$ 103,085	30	25 Year
Oro Vista Storm Drain- Foothill Blvd to Day Street	ULAR	LABOE	City	Grey Infrastructure	Stormwater Conveyance	No	No	Yes		\$ -	\$ 1,273,400	\$ 63,670	30	25 Year
Osborne Street - Haddon to Pacoima Ch	ULAR	LABOE	City	Grey Infrastructure	Stormwater Conveyance	No	No	Yes		\$ -	\$ 4,337,000	\$ 216,850	30	25 Year
Oxnard - Tampa to Shirley	ULAR	LABOE	City	Grey Infrastructure	Stormwater Conveyance	No	No	Yes		\$ -	\$ 1,146,000	\$ 57,300	30	25 Year
Oxnard At Whitnall Hwy	ULAR	LABOE	City	Grey Infrastructure	Stormwater Conveyance	No	No	Yes		\$ -	\$ 1,409,600	\$ 70,480	30	25 Year
Oxnard St - Greenbush To Allott	ULAR	LABOE	City	Grey Infrastructure	Stormwater Conveyance	No	No	Yes		\$ -	\$ 412,600	\$ 20,630	30	25 Year
Oxnard Street - Fulcher Ave to Elmer Ave SD	ULAR	LABOE	City	Grey Infrastructure	Stormwater Conveyance	No	No	Yes		\$ -	\$ 1,138,500	\$ 56,925	30	25 Year
Oxnard Street - Tujunga Ave to Lankershim Blvd	ULAR	LABOE	City	Grey Infrastructure	Stormwater Conveyance	No	No	Yes		\$ -	\$ 797,600	\$ 39,880	30	25 Year
Pacific Avenue SD - 26th St to 28th St	DC	LABOE	City	Grey Infrastructure	Stormwater Conveyance	No	No	Yes		\$ -	\$ 885,400	\$ 44,270	30	25 Year
Paige Street SD	ULAR	LABOE	City	Grey Infrastructure	Stormwater Conveyance	No	No	Yes		\$ -	\$ 198,000	\$ 9,900	30	25 Year
Panorama Channel Reconstruction	ULAR	LABOE	City	Grey Infrastructure	Stormwater Conveyance	No	No	Yes		\$ -	\$ 2,573,900	\$ 128,695	30	25 Year

Project Name	Watershed	Lead Agency	Project Type	Project Category	Project Size	Known Water Quality Benefit?	Known Water Supply Benefit ?	Known Flood Risk Mitigation Benefit?	Other Considerations	Green Infrastructure Capital Cost	Grey Infrastructure Capital Cost	Annual O&M Cost	Selection Order	SIP Phase
Parthenia St- Owensmouth To Topanga Cyn	ULAR	LABOE	City	Grey Infrastructure	Stormwater Conveyance	No	No	Yes		\$ -	\$ 654,900	\$ 32,745	30	25 Year
Parthenia St White Oak Av To Zelzah	ULAR	LABOE	City	Grey Infrastructure	Stormwater Conveyance	No	No	Yes		\$ -	\$ 603,500	\$ 30,175	30	25 Year
Partridge Avenue Storm Drain	ULAR	LABOE	City	Grey Infrastructure	Stormwater Conveyance	No	No	Yes		\$ -	\$ 208,300	\$ 10,415	30	25 Year
Pendleton - Roscoe To Amboy	ULAR	LABOE	City	Grey Infrastructure	Stormwater Conveyance	No	No	Yes		\$ -	\$ 990,200	\$ 49,510	30	25 Year
Peoria St-Dronfield 10 foot Esmt To Glenoaks	ULAR	LABOE	City	Grey Infrastructure	Stormwater Conveyance	No	No	Yes		\$ -	\$ 1,925,300	\$ 96,265	30	25 Year
Pierce - Sharp To Pacoima Wash	ULAR	LABOE	City	Grey Infrastructure	Stormwater Conveyance	No	No	Yes		\$ -	\$ 1,306,500	\$ 65,325	30	25 Year
Pinewood Foothill	ULAR	LABOE	City	Grey Infrastructure	Stormwater Conveyance	No	No	Yes		\$ -	\$ 848,500	\$ 42,425	30	25 Year
Plummer Street at Pacoima Wash SD	ULAR	LABOE	City	Grey Infrastructure	Stormwater Conveyance	No	No	Yes		\$ -	\$ 1,156,000	\$ 57,800	30	25 Year
Prairie St. Winnetka Ave to Oso Ave	ULAR	LABOE	City	Grey Infrastructure	Stormwater Conveyance	No	No	Yes		\$ -	\$ 1,386,000	\$ 69,300	30	25 Year
Radford Av - Magnolia To Hartsook	ULAR	LABOE	City	Grey Infrastructure	Stormwater Conveyance	No	No	Yes		\$ -	\$ 275,000	\$ 13,750	30	25 Year
Radford Av - Saticoy To Stagg (requires Lankershim	ULAR	LABOE	City	Grey Infrastructure	Stormwater Conveyance	No	No	Yes		\$ -	\$ 1,994,100	\$ 99,705	30	25 Year
Rancho Encino SD	ULAR	LABOE	City	Grey Infrastructure	Stormwater Conveyance	No	No	Yes		\$ -	\$ 2,621,100	\$ 131,055	30	25 Year
Riverside Drive - Forman to Ledge	ULAR	LABOE	City	Grey Infrastructure	Stormwater Conveyance	No	No	Yes		\$ -	\$ 1,386,000	\$ 69,300	30	25 Year
Roscoe - Corbin To Oakdale	ULAR	LABOE	City	Grey Infrastructure	Stormwater Conveyance	No	No	Yes		\$ -	\$ 725,400	\$ 36,270	30	25 Year
Roscoe Boulevard - Mason to Oso	ULAR	LABOE	City	Grey Infrastructure	Stormwater Conveyance	No	No	Yes		\$ -	\$ 1,336,500	\$ 66,825	30	25 Year
Roscoe By Zelzah To Lindley SD	ULAR	LABOE	City	Grey Infrastructure	Stormwater Conveyance	No	No	Yes		\$ -	\$ 852,800	\$ 42,640	30	25 Year
Roscoe Dora SD	ULAR	LABOE	City	Grey Infrastructure	Stormwater Conveyance	No	No	Yes		\$ -	\$ 273,400	\$ 13,670	30	25 Year
Rossmore Avenue - 3rd Street SD	BC	LABOE	City	Grey Infrastructure	Stormwater Conveyance	No	No	Yes		\$ -	\$ 24,017,500	\$ 1,200,875	30	25 Year
Roxford St Herrick Av To Stetson Cyn Ch	ULAR	LABOE	City	Grey Infrastructure	Stormwater Conveyance	No	No	Yes		\$ -	\$ 1,508,500	\$ 75,425	30	25 Year
Royal Oak Rd W/O Sepulveda	ULAR	LABOE	City	Grey Infrastructure	Stormwater Conveyance	No	No	Yes		\$ -	\$ 2,337,900	\$ 116,895	30	25 Year
Royal Ridge Rd and Crownridge Pl	ULAR	LABOE	City	Grey Infrastructure	Stormwater Conveyance	No	No	Yes		\$ -	\$ 1,622,800	\$ 81,140	30	25 Year
Royer - Ostronic to N/O Dolorosa	ULAR	LABOE	City	Grey Infrastructure	Stormwater Conveyance	No	No	Yes		\$ -	\$ 1,100,200	\$ 55,010	30	25 Year
S.F. Mission And Laurel Cyn. Bl. SD	ULAR	LABOE	City	Grey Infrastructure	Stormwater Conveyance	No	No	Yes		\$ -	\$ 764,000	\$ 38,200	30	25 Year
S/O Skyland - N/O Big Tujung Cyn	ULAR	LABOE	City	Grey Infrastructure	Stormwater Conveyance	No	No	Yes		\$ -	\$ 440,100	\$ 22,005	30	25 Year
Samoa Hillrose SD	ULAR	LABOE	City	Grey Infrastructure	Stormwater Conveyance	No	No	Yes		\$ -	\$ 332,600	\$ 16,630	30	25 Year
San Pedro Street & 51st Street SD	ULAR	LABOE	City	Grey Infrastructure	Stormwater Conveyance	No	No	Yes		\$ -	\$ 4,634,400	\$ 231,720	30	25 Year
Santa Lucia Dr. - Cardenas Ave to Canoga Dr.	ULAR	LABOE	City	Grey Infrastructure	Stormwater Conveyance	No	No	Yes		\$ -	\$ 1,075,100	\$ 53,755	30	25 Year
Sarah St - Whitsett to Laurelgrove	ULAR	LABOE	City	Grey Infrastructure	Stormwater Conveyance	No	No	Yes		\$ -	\$ 1,045,200	\$ 52,260	30	25 Year
Sarah Sunnyslope	ULAR	LABOE	City	Grey Infrastructure	Stormwater Conveyance	No	No	Yes		\$ -	\$ 1,100,200	\$ 55,010	30	25 Year
Saticoy - Camellia to Lemp	ULAR	LABOE	City	Grey Infrastructure	Stormwater Conveyance	No	No	Yes		\$ -	\$ 693,000	\$ 34,650	30	25 Year
Saticoy - Lankershim To Radford	ULAR	LABOE	City	Grey Infrastructure	Stormwater Conveyance	No	No	Yes		\$ -	\$ 1,247,400	\$ 62,370	30	25 Year
Saticoy - Tujung To Vineland	ULAR	LABOE	City	Grey Infrastructure	Stormwater Conveyance	No	No	Yes		\$ -	\$ 1,602,800	\$ 80,140	30	25 Year
Saticoy St - Louise to Amestoy	ULAR	LABOE	City	Grey Infrastructure	Stormwater Conveyance	No	No	Yes		\$ -	\$ 928,300	\$ 46,415	30	25 Year
Saticoy St Balboa Bl To Bullcreek Channel	ULAR	LABOE	City	Grey Infrastructure	Stormwater Conveyance	No	No	Yes		\$ -	\$ 756,400	\$ 37,820	30	25 Year
Saticoy St SD W/O Woodley Ave.	ULAR	LABOE	City	Grey Infrastructure	Stormwater Conveyance	No	No	Yes		\$ -	\$ 399,500	\$ 19,975	30	25 Year
Saticoy St White Oak To Encino St	ULAR	LABOE	City	Grey Infrastructure	Stormwater Conveyance	No	No	Yes		\$ -	\$ 915,200	\$ 45,760	30	25 Year
Saticoy St Zelzah To Lindley	ULAR	LABOE	City	Grey Infrastructure	Stormwater Conveyance	No	No	Yes		\$ -	\$ 692,800	\$ 34,640	30	25 Year
Saticoy Tobias To Pacoima Wash	ULAR	LABOE	City	Grey Infrastructure	Stormwater Conveyance	No	No	Yes		\$ -	\$ 565,700	\$ 28,285	30	25 Year
Saticoy Yolanda SD	ULAR	LABOE	City	Grey Infrastructure	Stormwater Conveyance	No	No	Yes		\$ -	\$ 938,600	\$ 46,930	30	25 Year
Satsuma Av - Vanowen To Kittridge	ULAR	LABOE	City	Grey Infrastructure	Stormwater Conveyance	No	No	Yes		\$ -	\$ 893,900	\$ 44,695	30	25 Year
Scandia Way, 3900 Block	ULAR	LABOE	City	Grey Infrastructure	Stormwater Conveyance	No	No	Yes		\$ -	\$ 436,600	\$ 21,830	30	25 Year
SD N/O Sherman Way - Betw Ranchito And Woodman	ULAR	LABOE	City	Grey Infrastructure	Stormwater Conveyance	No	No	Yes		\$ -	\$ 275,000	\$ 13,750	30	25 Year
SD S/O Lankershim and Ventura	ULAR	LABOE	City	Grey Infrastructure	Stormwater Conveyance	No	No	Yes		\$ -	\$ 1,885,700	\$ 94,285	30	25 Year
SD S/O Vanalden Av and Retarding Basin	ULAR	LABOE	City	Grey Infrastructure	Stormwater Conveyance	No	No	Yes		\$ -	\$ 1,709,800	\$ 85,490	30	25 Year
Sepulveda Bl - W/O Valley Meadow to Steven Dr	ULAR	LABOE	City	Grey Infrastructure	Stormwater Conveyance	No	No	Yes		\$ -	\$ 4,058,900	\$ 202,945	30	25 Year
Serrania Avenue SD - Ventura Blvd to Dumetz Rd	ULAR	LABOE	City	Grey Infrastructure	Stormwater Conveyance	No	No	Yes		\$ -	\$ 1,855,900	\$ 92,795	30	25 Year
Sespe Ave - Tustin to Sutton	ULAR	LABOE	City	Grey Infrastructure	Stormwater Conveyance	No	No	Yes		\$ -	\$ 359,200	\$ 17,960	30	25 Year
Sherman Way - Vineland To Fair	ULAR	LABOE	City	Grey Infrastructure	Stormwater Conveyance	No	No	Yes		\$ -	\$ 962,600	\$ 48,130	30	25 Year
Sherman Way & Capps Avenue SD	ULAR	LABOE	City	Grey Infrastructure	Stormwater Conveyance	No	No	Yes		\$ -	\$ 3,723,200	\$ 186,160	30	25 Year
Sherman Way And Clybourn	ULAR	LABOE	City	Grey Infrastructure	Stormwater Conveyance	No	No	Yes		\$ -	\$ 1,650,300	\$ 82,515	30	25 Year
Shirley Av SD - LA River To Hartland St	ULAR	LABOE	City	Grey Infrastructure	Stormwater Conveyance	No	No	Yes		\$ -	\$ 1,164,200	\$ 58,210	30	25 Year
Shoup Av - Kittridge to Vanowen	ULAR	LABOE	City	Grey Infrastructure	Stormwater Conveyance	No	No	Yes		\$ -	\$ 522,600	\$ 26,130	30	25 Year
Speedway Water Quality and Drainage Improvement	SMB	LABOE	City	Grey Infrastructure	Stormwater Conveyance	No	No	Yes		\$ -	\$ 6,788,300	\$ 339,415	30	25 Year
SPRR R/W To Vineland And Riverton	ULAR	LABOE	City	Grey Infrastructure	Stormwater Conveyance	No	No	Yes		\$ -	\$ 2,200,300	\$ 110,015	30	25 Year
Stone Street SD North of Ganahl Street	ULAR	LABOE	City	Grey Infrastructure	Stormwater Conveyance	No	No	Yes		\$ -	\$ 436,600	\$ 21,830	30	25 Year
Strathern St - Corbin to Oakdale	ULAR	LABOE	City	Grey Infrastructure	Stormwater Conveyance	No	No	Yes		\$ -	\$ 687,600	\$ 34,380	30	25 Year
Strathern St - Louise To Amestoy Av S D	ULAR	LABOE	City	Grey Infrastructure	Stormwater Conveyance	No	No	Yes		\$ -	\$ 755,900	\$ 37,795	30	25 Year
Strathern St - Oso to Winnetka	ULAR	LABOE	City	Grey Infrastructure	Stormwater Conveyance	No	No	Yes		\$ -	\$ 825,100	\$ 41,255	30	25 Year
Strathern St - Tampa to Shirley	ULAR	LABOE	City	Grey Infrastructure	Stormwater Conveyance	No	No	Yes		\$ -	\$ 880,100	\$ 44,005	30	25 Year
Strathern St - Yolanda To Wilbur	ULAR	LABOE	City	Grey Infrastructure	Stormwater Conveyance	No	No	Yes		\$ -	\$ 715,100	\$ 35,755	30	25 Year
Strathern St Laurel Cyn Bl To Hwd Fwy	ULAR	LABOE	City	Grey Infrastructure	Stormwater Conveyance	No	No	Yes		\$ -	\$ 3,299,900	\$ 164,995	30	25 Year
Sunland Boulevard & Glenoaks Boulevard SD	ULAR	LABOE	City	Grey Infrastructure	Stormwater Conveyance	No	No	Yes		\$ -	\$ 1,268,200	\$ 63,410	30	25 Year
Sutter Av Paxton St To 220 feet N/O Filmore	ULAR	LABOE	City	Grey Infrastructure	Stormwater Conveyance	No	No	Yes		\$ -	\$ 817,300	\$ 40,865	30	25 Year
Sylmar Av - Delano To Kittridge	ULAR	LABOE	City	Grey Infrastructure	Stormwater Conveyance	No	No	Yes		\$ -	\$ 1,444,000	\$ 72,200	30	25 Year
Telfair Avenue R/W E/O Polk St to Astoria St	ULAR	LABOE	City	Grey Infrastructure	Stormwater Conveyance	No	No	Yes		\$ -	\$ 1,633,400	\$ 81,670	30	25 Year
Terra Bella St-Eldridge	ULAR	LABOE	City	Grey Infrastructure	Stormwater Conveyance	No	No	Yes		\$ -	\$ 1,737,200	\$ 86,860	30	25 Year
Thornton Ave SD Outlet Ext	ULAR	LABOE	City	Grey Infrastructure	Stormwater Conveyance	No	No	Yes		\$ -	\$ 2,385,300	\$ 119,265	30	25 Year
Topanga Cyn Bl - Hart To Sherman Way	ULAR	LABOE	City	Grey Infrastructure	Stormwater Conveyance	No	No	Yes		\$ -	\$ 962,600	\$ 48,130	30	25 Year
Topanga Cyn Bl Valerio St To Bell Creek	ULAR	LABOE	City	Grey Infrastructure	Stormwater Conveyance	No	No	Yes		\$ -	\$ 2,639,900	\$ 131,995	30	25 Year

Project Name	Watershed	Lead Agency	Project Type	Project Category	Project Size	Known Water Quality Benefit?	Known Water Supply Benefit ?	Known Flood Risk Mitigation Benefit?	Other Considerations	Green Infrastructure Capital Cost	Grey Infrastructure Capital Cost	Annual O&M Cost	Selection Order	SIP Phase
Towne Avenue - 81st St to 84th St	ULAR	LABOE	City	Grey Infrastructure	Stormwater Conveyance	No	No	Yes		\$ -	\$ 1,555,400	\$ 77,770	30	25 Year
Tujunga Canyon Boulevard SD - N/O Valmont St	ULAR	LABOE	City	Grey Infrastructure	Stormwater Conveyance	No	No	Yes		\$ -	\$ 1,459,500	\$ 72,975	30	25 Year
Tyrone Av - Collins To Califa	ULAR	LABOE	City	Grey Infrastructure	Stormwater Conveyance	No	No	Yes		\$ -	\$ 935,100	\$ 46,755	30	25 Year
Tyrone Av - Magnolia To Chandler	ULAR	LABOE	City	Grey Infrastructure	Stormwater Conveyance	No	No	Yes		\$ -	\$ 893,900	\$ 44,695	30	25 Year
Valerio St - Etiwanda To Canby	ULAR	LABOE	City	Grey Infrastructure	Stormwater Conveyance	No	No	Yes		\$ -	\$ 481,300	\$ 24,065	30	25 Year
Valley Meadow Rd - W/O Valley Meadow to Castlewood	ULAR	LABOE	City	Grey Infrastructure	Stormwater Conveyance	No	No	Yes		\$ -	\$ 1,856,500	\$ 92,825	30	25 Year
Valley Vista Bl and Madelia Av	ULAR	LABOE	City	Grey Infrastructure	Stormwater Conveyance	No	No	Yes		\$ -	\$ 962,600	\$ 48,130	30	25 Year
Valley Vista Blvd Sunnyslope Ave SD	ULAR	LABOE	City	Grey Infrastructure	Stormwater Conveyance	No	No	Yes		\$ -	\$ 2,592,800	\$ 129,640	30	25 Year
Van Nuys - Gladstone to Fenton	ULAR	LABOE	City	Grey Infrastructure	Stormwater Conveyance	No	No	Yes		\$ -	\$ 1,781,900	\$ 89,095	30	25 Year
Van Nuys - Laurel Cyn To Oneida	ULAR	LABOE	City	Grey Infrastructure	Stormwater Conveyance	No	No	Yes		\$ -	\$ 1,031,400	\$ 51,570	30	25 Year
Van Nuys Blvd - Nordhoff St SD	ULAR	LABOE	City	Grey Infrastructure	Stormwater Conveyance	No	No	Yes		\$ -	\$ 4,900,300	\$ 245,015	30	25 Year
Vanalden Av - Hartland to Sherman Way	ULAR	LABOE	City	Grey Infrastructure	Stormwater Conveyance	No	No	Yes		\$ -	\$ 2,168,500	\$ 108,425	30	25 Year
Vanalden Avenue - Bessemer Street SD	ULAR	LABOE	City	Grey Infrastructure	Stormwater Conveyance	No	No	Yes		\$ -	\$ 1,939,200	\$ 96,960	30	25 Year
Vanalden Avenue - Shenango Drive SD	ULAR	LABOE	City	Grey Infrastructure	Stormwater Conveyance	No	No	Yes		\$ -	\$ 1,886,000	\$ 94,300	30	25 Year
Vanowen - Gloria to Woodley	ULAR	LABOE	City	Grey Infrastructure	Stormwater Conveyance	No	No	Yes		\$ -	\$ 1,386,000	\$ 69,300	30	25 Year
Vanowen Bertrand SD	ULAR	LABOE	City	Grey Infrastructure	Stormwater Conveyance	No	No	Yes		\$ -	\$ 3,167,900	\$ 158,395	30	25 Year
Vanowen Farmdale SD	ULAR	LABOE	City	Grey Infrastructure	Stormwater Conveyance	No	No	Yes		\$ -	\$ 930,600	\$ 46,530	30	25 Year
Vanowen St - 405 Frwy To Orion Av	ULAR	LABOE	City	Grey Infrastructure	Stormwater Conveyance	No	No	Yes		\$ -	\$ 722,000	\$ 36,100	30	25 Year
Vanowen St - Goodland To Bellaire	ULAR	LABOE	City	Grey Infrastructure	Stormwater Conveyance	No	No	Yes		\$ -	\$ 550,100	\$ 27,505	30	25 Year
Vanowen St Corbin Av To Oakdale Av	ULAR	LABOE	City	Grey Infrastructure	Stormwater Conveyance	No	No	Yes		\$ -	\$ 755,900	\$ 37,795	30	25 Year
Vanowen St White Oak To Encino	ULAR	LABOE	City	Grey Infrastructure	Stormwater Conveyance	No	No	Yes		\$ -	\$ 964,000	\$ 48,200	30	25 Year
Vanowen Street - Calhoun to Tyrone	ULAR	LABOE	City	Grey Infrastructure	Stormwater Conveyance	No	No	Yes		\$ -	\$ 467,600	\$ 23,380	30	25 Year
Varna Av - Wyandotte To Sherman Way	ULAR	LABOE	City	Grey Infrastructure	Stormwater Conveyance	No	No	Yes		\$ -	\$ 357,600	\$ 17,880	30	25 Year
Ventura Bl - Vantage To Laurelgrove	ULAR	LABOE	City	Grey Infrastructure	Stormwater Conveyance	No	No	Yes		\$ -	\$ 660,100	\$ 33,005	30	25 Year
Ventura Blvd & Del Moreno Dr SD	ULAR	LABOE	City	Grey Infrastructure	Stormwater Conveyance	No	No	Yes		\$ -	\$ 1,509,300	\$ 75,465	30	25 Year
Ventura Blvd & Sunnyslope Ave SD	ULAR	LABOE	City	Grey Infrastructure	Stormwater Conveyance	No	No	Yes		\$ -	\$ 3,167,900	\$ 158,395	30	25 Year
Ventura Boulevard - Corbin Avenue SD	ULAR	LABOE	City	Grey Infrastructure	Stormwater Conveyance	No	No	Yes		\$ -	\$ 2,262,800	\$ 113,140	30	25 Year
Victory Bl - Fulton To Allott	ULAR	LABOE	City	Grey Infrastructure	Stormwater Conveyance	No	No	Yes		\$ -	\$ 440,100	\$ 22,005	30	25 Year
Victory Blvd - Fair Ave SD	ULAR	LABOE	City	Grey Infrastructure	Stormwater Conveyance	No	No	Yes		\$ -	\$ 1,261,700	\$ 63,085	30	25 Year
Vinedale - Vinevalley To La Tuna SD	ULAR	LABOE	City	Grey Infrastructure	Stormwater Conveyance	No	No	Yes		\$ -	\$ 577,600	\$ 28,880	30	25 Year
Wall St and 43rd St Storm Drain	ULAR	LABOE	City	Grey Infrastructure	Stormwater Conveyance	No	No	Yes		\$ -	\$ 591,000	\$ 29,550	30	25 Year
Wall Street - 97th St to Century Blvd	ULAR	LABOE	City	Grey Infrastructure	Stormwater Conveyance	No	No	Yes		\$ -	\$ 654,900	\$ 32,745	30	25 Year
Wall Street & 59th Place SD	ULAR	LABOE	City	Grey Infrastructure	Stormwater Conveyance	No	No	Yes		\$ -	\$ 1,086,600	\$ 54,330	30	25 Year
Warwick Avenue SD - Unit 2	ULAR	LABOE	City	Grey Infrastructure	Stormwater Conveyance	No	No	Yes		\$ -	\$ 1,960,700	\$ 98,035	30	25 Year
Western Avenue and Paseo Del Mar Drop Structure	SMB	LABOE	City	Grey Infrastructure	Stormwater Conveyance	No	No	Yes		\$ -	\$ 3,118,400	\$ 155,920	30	25 Year
Wheatland Avenue E/O Debris Basin N/O Foothill	ULAR	LABOE	City	Grey Infrastructure	Stormwater Conveyance	No	No	Yes		\$ -	\$ 873,200	\$ 43,660	30	25 Year
Whitsett Avenue - Stagg Street SD	ULAR	LABOE	City	Grey Infrastructure	Stormwater Conveyance	No	No	Yes		\$ -	\$ 2,870,900	\$ 143,545	30	25 Year
Wicks St - Dronfield To Glenoaks Bl	ULAR	LABOE	City	Grey Infrastructure	Stormwater Conveyance	No	No	Yes		\$ -	\$ 1,925,300	\$ 96,265	30	25 Year
Wicks St - Telfair To Sharp Av	ULAR	LABOE	City	Grey Infrastructure	Stormwater Conveyance	No	No	Yes		\$ -	\$ 2,750,400	\$ 137,520	30	25 Year
Winnetka and Hatteras	ULAR	LABOE	City	Grey Infrastructure	Stormwater Conveyance	No	No	Yes		\$ -	\$ 891,900	\$ 44,595	30	25 Year
Winter Street & Fresno Street Catch Basin	ULAR	LABOE	City	Grey Infrastructure	Stormwater Conveyance	No	No	Yes		\$ -	\$ 30,100	\$ 1,505	30	25 Year
Woodlake Erwin SD	ULAR	LABOE	City	Grey Infrastructure	Stormwater Conveyance	No	No	Yes		\$ -	\$ 2,969,900	\$ 148,495	30	25 Year
Woodley Av & Morrison St SD	ULAR	LABOE	City	Grey Infrastructure	Stormwater Conveyance	No	No	Yes		\$ -	\$ 2,969,900	\$ 148,495	30	25 Year
Woodward Av McGroarty To Haines Chnl	ULAR	LABOE	City	Grey Infrastructure	Stormwater Conveyance	No	No	Yes		\$ -	\$ 907,600	\$ 45,380	30	25 Year
Wyandotte St - Noble To Kester	ULAR	LABOE	City	Grey Infrastructure	Stormwater Conveyance	No	No	Yes		\$ -	\$ 907,600	\$ 45,380	30	25 Year
Zelzah Avenue - Devonshire to Lassen	ULAR	LABOE	City	Grey Infrastructure	Stormwater Conveyance	No	No	Yes		\$ -	\$ 2,337,900	\$ 116,895	30	25 Year
Zelzah Avenue SD - Victory Blvd to Kittridge St	ULAR	LABOE	City	Grey Infrastructure	Stormwater Conveyance	No	No	Yes		\$ -	\$ 842,800	\$ 42,140	30	25 Year
Arleta Greenbelt	ULAR	Others - The River Project	None City	Green Infrastructure	Centralized	Yes	Yes	Yes	Community Beautification	\$ 30,000,000	\$ -	\$ 1,500,000	31	
Lanark park	ULAR		None City	Green Infrastructure	Centralized	Yes	Yes	Yes	Open Space and Recreation	\$ 1,000,000	\$ -	\$ 50,000	31	
Mission Hills Greenbelt	ULAR	Others - The River Project	None City	Green Infrastructure	Centralized	Yes	Yes	Yes	Community Beautification	\$ 5,000,000	\$ -	\$ 65,000	31	
Bull Creek Soft Channel Improvement	ULAR	LACFCD	None City	Green Infrastructure	Centralized	Yes	Yes	Yes	Recreation Opportunity	\$ 188,274,878	\$ -	\$ 3,351,258	31	
Miller Pit Spreading Ground	ULAR	LACFCD	None City	Green - Grey Infrastructure	Centralized	Yes	Yes	Yes	Habitat Restoration	\$ 35,852,400	\$ -	\$ 133,604	31	
Piggyback Yard	ULAR	USACE	None City	Green Infrastructure	Centralized	Yes	Yes	Yes	Habitat Restoration	\$ 11,904,650	\$ -	\$ 43,906	31	
Sepulveda Dam Spreading Grounds	ULAR	LACFCD	None City	Green - Grey Infrastructure	Centralized	Yes	Yes	Yes	Habitat Restoration	\$ 72,971,282	\$ -	\$ 780,307	31	
Sun Valley Middle School	ULAR	LAUSD	None City	Green - Grey Infrastructure	Centralized	Yes	Yes	Yes	Funding-LADWP	\$ 100,000	\$ -	\$ 5,000	31	
Browns Creek Area Spreading Grounds	ULAR	LACFCD	None City	Green - Grey Infrastructure	Centralized	Yes	Yes	Yes	Habitat Restoration	\$ 49,328,504	\$ -	\$ 572,147	31	
Bull Creek Area Spreading Grounds	ULAR	LACFCD	None City	Green - Grey Infrastructure	Centralized	Yes	Yes	Yes	Habitat Restoration	\$ 27,076,366	\$ -	\$ 572,147	31	
Caballero Creek & Los Angeles River Confluence Park	ULAR	Others - MRCA	None City	Green Infrastructure	Centralized	Yes	Yes	Yes	Open Space and Recreation	\$ 3,004,475	\$ -	\$ 18,000	31	
Chester L. Washington Golf Course	DC	LA County	None City	Green Infrastructure	Centralized	Yes	Yes	Yes	Open Space and Recreation	\$ 59,600,000	\$ -	\$ 500,000	31	

Project Name	Watershed	Lead Agency	Project Type	Project Category	Project Size	Known Water Quality Benefit?	Known Water Supply Benefit ?	Known Flood Risk Mitigation Benefit?	Other Considerations	Green Infrastructure Capital Cost	Grey Infrastructure Capital Cost	Annual O&M Cost	Selection Order	SIP Phase
Ladera Park Field Subsurface Infiltration Regional BMP	BC	LACDPW/LACDPR	None City	Green Infrastructure	Centralized	Yes	Yes	Yes	Open Space and Recreation	\$ 9,670,000	\$ -	\$ 20,000	31	
Marsh Park, Phase II	ULAR	Others - MRCA	None City	Green Infrastructure	Centralized	Yes	Yes	Yes	Open Space and Recreation	\$ 5,830,959	\$ -	\$ 150,000	31	
San Rafael Creek Restoration	ULAR	Others - Arroyo Seco Foundation	None City	Green Infrastructure	Centralized	Yes	Yes	Yes	Habitat Restoration	\$ 2,000,000	\$ -	\$ 15,000	31	
Aliso Creek Soft Channel Improvement	ULAR	LACFC	None City	Green Infrastructure	Centralized	Yes	Yes	Yes	Habitat Restoration	\$ 419,406,548	\$ -	\$ 7,374,609	31	
Arroyo Seco Land	ULAR	USACE	None City	Green Infrastructure	Centralized	Yes	Yes	Yes	Habitat Restoration	\$ 1,000,000	\$ -	\$ 50,000	31	
Verdugo Wash Land	ULAR	USACE	None City	Green Infrastructure	Centralized	Yes	Yes	Yes	Habitat Restoration	\$ 1,000,000	\$ -	\$ 50,000	31	
Arroyo Seco Soft Channel Improvement	ULAR	LACFC	None City	Green Infrastructure	Centralized	Yes	Yes	Yes	Habitat Restoration	\$ 672,160,822	\$ -	\$ 11,890,729	31	
Brown Creek Soft Channel Improvement	ULAR	LACFC	None City	Green Infrastructure	Centralized	Yes	Yes	Yes	Habitat Restoration	\$ 721,196,876	\$ -	\$ 12,819,113	31	
Santa Susana Creek at Topanga Canyon and Plummer	ULAR	Others - MRCA	None City	Green Infrastructure	Centralized	Yes	Yes	Yes	Habitat Restoration	\$ 500,000	\$ -	\$ 25,000	31	
Bell Creek Soft Channel Imporevement	ULAR	LACFC	None City	Green Infrastructure	Centralized	Yes	Yes	Yes		\$ 106,467,914	\$ -	\$ 1,895,796	31	
Browns Canyon Wash at Plummer and Variel	ULAR	Others - MRCA	None City	Green Infrastructure	Centralized	Yes	Yes	Yes		\$ 15,000,000	\$ -	\$ 750,000	31	
Stonehurst School	ULAR		None City	Green - Grey Infrastructure	Centralized	Yes	Yes	Yes		\$ 100,000	\$ -	\$ 5,000	31	
Tujunga and Pacoima Wash Bridge Retrofit and Channel Expansion	ULAR	Others - The River Project	None City	Green Infrastructure	Centralized	Yes	Yes	Yes		\$ 100,000,000	\$ -	\$ 3,000,000	31	
Tujunga Wash Soft Channel Improvement	ULAR	LACFC	None City	Green Infrastructure	Centralized	Yes	Yes	Yes		\$ 812,165,273	\$ -	\$ 14,461,632	31	
Verdugo Hills High School Retrofit	ULAR		None City	Green Infrastructure	Centralized	Yes	Yes	Yes		\$ 100,000	\$ -	\$ 5,000	31	
CBS-Viacom Radio Community Park	ULAR	Others - The River Project	None City	Green Infrastructure	Centralized	Yes	Yes	No	Open Space and Recreation	\$ 5,500,000	\$ -	\$ 100,000	31	
Edward Vincent Junior Park Regional BMP	BC	Others - Inglewood	None City	Green Infrastructure	Centralized	Yes	Yes	No	Open Space and Recreation	\$ 44,891,000	\$ -	\$ 1,000,000	31	
Hollenbeck Middle School; Boyle Heights Green Corridor Project	ULAR		None City	Green Infrastructure	Centralized	Yes	Yes	No	Community Beautification	\$ 1,000,000	\$ -	\$ 50,000	31	
Pierce College	ULAR		None City	Green Infrastructure	Centralized	Yes	Yes	No	Community Beautification	\$ 500,000	\$ -	\$ 25,000	31	
Valley Plaza Park	ULAR		None City	Green Infrastructure	Centralized	Yes	Yes	No	Community Beautification	\$ 1,000,000	\$ -	\$ 50,000	31	
Van Nuys Sherman Oaks Park	ULAR		None City	Green Infrastructure	Centralized	Yes	Yes	No	Open Space and Recreation	\$ 1,000,000	\$ -	\$ 50,000	31	
Culver Boulevard Median Regional BMP	BC	Others - Culver City	None City	Green Infrastructure	Centralized	Yes	Yes	No	Community Beautification	\$ 16,550,000	\$ -	\$ 827,500	31	
La Cienega Park Regional BMP	BC	Others - Beverly Hills	None City	Green Infrastructure	Centralized	Yes	Yes	No	Open Space and Recreation	\$ 32,176,000	\$ -	\$ 1,608,800	31	
Lower Arroyo Park	ULAR	Others - South Pasadena	None City	Green Infrastructure	Centralized	Yes	Yes	No	Open Space and Recreation	\$ 5,132,000	\$ -	\$ 256,600	31	
Plummer Park Regional BMP	BC	Others - West Hollywood	None City	Green Infrastructure	Centralized	Yes	Yes	No	Open Space and Recreation	\$ 12,508,000	\$ -	\$ 625,400	31	
Welch Site BMP	ULAR		None City	Green Infrastructure	Centralized	Yes	Yes	Yes		\$ 1,000,000	\$ -	\$ 50,000	31	
Browns Canyon Wash at Route 118 and Rinaldi	ULAR	Others - MRCA	None City	Green Infrastructure	Centralized	Yes	Yes	Yes		\$ 4,000,000	\$ -	\$ 200,000	31	
Burbank West Soft Channel Improvement	ULAR	LACFC	None City	Green Infrastructure	Centralized	Yes	Yes	Yes		\$ 72,655,637	\$ -	\$ 1,293,726	31	
Sycamore Grove Park	ULAR		None City	Green Infrastructure	Centralized	Yes	Yes	No	Open Space and Recreation	\$ 1,000,000	\$ -	\$ 50,000	31	
Vacant Parcel Adjacent to Compton Creek	ULAR		None City	Green Infrastructure	Centralized	Yes	Yes	No	Habitat Restoration	\$ 5,000,000	\$ -	\$ 250,000	31	
Reach 4- Upstream Glendale Narrows to Los Feliz	ULAR	USACE	None City	Green Infrastructure	Centralized	Yes	No	Yes	Habitat Restoration	\$ 14,884,848	\$ -	\$ 206,588	31	
Reach 5- Los Feliz to Bowtie Parcel	ULAR	USACE	None City	Green Infrastructure	Centralized	Yes	No	Yes	Habitat Restoration	\$ 107,500	\$ -	\$ 83,025	31	
Reach 6- Bowtie Parcel to Downtown Glendale Narrows/Arroyo Seco	ULAR	USACE	None City	Green Infrastructure	Centralized	Yes	No	Yes	Habitat Restoration	\$ 19,780,215	\$ -	\$ 324,327	31	
Reach 7- Downstream Glendale Narrows/Arroyo Seco to Main Street	ULAR	USACE	None City	Green Infrastructure	Centralized	Yes	No	Yes	Habitat Restoration	\$ 22,748,788	\$ -	\$ 109,913	31	
Reach 8-Main Street to First Street	ULAR	USACE	None City	Green Infrastructure	Centralized	Yes	No	Yes	Habitat Restoration	\$ 1,287,472	\$ -	\$ 102,057	31	
Reach 3- Ferrero Fields to Upstream Glendale Narrows	ULAR	USACE	None City	Green Infrastructure	Centralized	Yes	No	Yes	Habitat Restoration	\$ 16,131,172	\$ -	\$ 256,943	31	
Lincoln Heights Freeway Interchange BMP	ULAR		None City	Green Infrastructure	Centralized	Yes	Yes	No		\$ 3,000,000	\$ -	\$ 150,000	31	
Tujunga Tataviam Village Parks	ULAR	Others - Tataviam	None City	Green Infrastructure	Centralized	Yes	Yes	No		\$ 5,000,000	\$ -	\$ 300,000	31	
Tujunga-Sun Valley Tujunga Wash Diversion #1	ULAR	LACFC	None City	Green Infrastructure	Centralized	Yes	Yes	No		\$ 30,000,000	\$ -	\$ 1,500,000	31	
Tujunga-Sun Valley Tujunga Wash Diversion #2	ULAR	LACFC	None City	Green Infrastructure	Centralized	Yes	Yes	No		\$ 30,000,000	\$ -	\$ 1,500,000	31	
Vulcan Gravel Processing Plant	ULAR		None City	Green Infrastructure	Centralized	Yes	Yes	No		\$ 5,000,000	\$ -	\$ 250,000	31	
Wilson Canyon Wash and Sylmar High School Retrofit	ULAR	Others - The River Project	None City	Green Infrastructure	Centralized	Yes	Yes	No		\$ 5,500,000	\$ -	\$ 100,000	31	
Garvanza Elementary school	ULAR		None City	Green Infrastructure	Centralized	Yes	Yes	No		\$ 100,000	\$ -	\$ 5,000	31	
Santa Monica Civic Auditorium and Courthouse	SMB	Others - Santa Monica	None City	Green Infrastructure	Centralized	Yes	Yes	No		\$ 6,680,311	\$ -	\$ 334,016	31	
Primary Road Improvement Project	ULAR	Others - The River Project	None City	Green Infrastructure	Distributed	Yes	Yes	No		\$ 10,000,000	\$ -	\$ 600,000	31	
Railroad ROW Improvement	ULAR	Others - The River Project	None City	Green Infrastructure	Distributed	Yes	Yes	No		\$ 50,000,000	\$ -	\$ 3,000,000	31	
Arroyo Seco North Branch Creek Daylighting	ULAR	Others - The River Project	None City	Green Infrastructure	Centralized	Yes	No	No	Habitat Restoration	\$ 1,060,000	\$ -	\$ 53,000	31	

APPENDIX E – POLICIES AND PROGRAMS

Quadrant 2: Higher Priority, Easier to Implement				
Policy Number	Policy Lead	Policy Concept Language		Recommend to Water Cabinet
8	All City Depts.	Maximize use of City owned property for stormwater capture retrofits.		✓
Category	Support	Considerations	Source(s)	Multiple Sources & Objectives
Promote Integrated Planning & Design	LADWP, LASAN	1) Prioritize groundwater recharge (where appropriate) and/or detain water for reuse in irrigation, while meeting or improving water quality standards. 2) Ensure that LID is required for City-owned properties. 3) Evaluate surplus property modifications to capture more Stormwater. 4) Include vacant lots and any publically owned alleys in evaluation. 5) Do not prioritize at expense of pursuing single family home retrofits. 6) Develop opportunity evaluation checklist as a tool for all City Departments. Use Stormwater Capture Master Plan project evaluation checklist as a model to build on. 7) Property owner is the lead (ex. RAP is a the lead agency for all park projects which are a key opportunity) or consulted to approve proposed concept. 8) Expand on the Green Sustainable Streets Council Motion (14-0748) to include ET under capture and reuse. Allow other priority items, in order, per ordinance. 9) Utilize database of city-owned properties including vacant lots developed by Mayor's Operations Innovation Team.	LASAN, Steering Committee, Stakeholder Workshop	✓
Policy Number	Policy Lead	Policy Concept Language		Recommend to Water Cabinet
10	LASAN	Maximize water supply opportunities in water quality compliance and improvement projects and programs.		✗
Category	Support	Considerations	Source(s)	Multiple Sources & Objectives
Promote Integrated Planning & Design	All City Depts.	Identify a process to quantify water supply benefit early in the design process.	LASAN, LA Basin Study	✓
Policy Number	Policy Lead	Policy Concept Language		Recommend to Water Cabinet
18	DCP	Streamline the process and coordinate the timing of approvals for builders implementing LID and Green Building requirements.		✗
Category	Support	Considerations	Source(s)	Multiple Sources & Objectives
Improve Collaboration & Streamline Implementation	LASAN, DCP, LADBS	1) Work with Re:Code LA and Build LA teams to revise process to make sure LID design requirements are indicated at beginning of project. 2) Ensure all requirements are clear. 3) Include more training for counter staff.	Workshop, Small business community, developers	✓

Policy Number	Policy Lead	Policy Concept Language		Recommend to Water Cabinet
11	LASAN, LADWP, BOE	Create a city-wide database to identify collaborative opportunities for water-related multi-benefit projects.		✓
Category	Support	Considerations	Source(s)	Multiple Sources & Objectives
Promote Integrated Planning & Design	All City Depts., LA County, Other Regional Entities	<p>Database to be shared between agencies and will be designed to facilitate cooperation and collaboration, leverage resources and minimize neighborhood disruption.</p> <p>1) Include agencies and utilities with projects in the public ROW. 2) Determine best approach to include projects or opportunities with regional entities including LAUSD and LADPW. 3) Determine where to house and who maintains. 4) Consider GeoHub, Navigate LA (reservation system), or LADOT's project dashboard as potential platforms. Example uses: a) Tool to collaborate with Caltrans for Urban Runoff Green Streets. b) Leverage major infrastructure investments for LA River revitalization. c) Leverage Great Streets efforts to incorporate more watershed management features. 5) Evaluate how to incorporate GRASS evaluation process into City prioritization of stormwater greenway projects. 6) Use as a tool to evaluate impact of upstream BMP installation on the need for larger downstream projects over time.</p>	Funding STG, Steering, SCMP, GRASS, LASAN	✓
Policy Number	Policy Lead	Policy Concept Language		Recommend to Water Cabinet
20	LASAN	Create a vehicle for continued department and regional agency collaboration beyond One Water LA 2040 Plan Development.		✓
Category	Support	Considerations	Source(s)	Multiple Sources & Objectives
Improve Collaboration & Streamline Implementation	Water Cabinet, All City Depts.,	Continue and build upon structure and function of One Water LA Steering Committee. This vehicle/committee will allow for adaptive management through continued evaluation of necessary policy changes, further discussion of long-term alternatives and identification of additional integration opportunities. Consider staff resourcing implications.	Steering Committee, Living Streets	✓
Policy Number	Policy Lead	Policy Concept Language		Recommend to Water Cabinet
33	LASAN, BSS	Require Green Street implementation to use sustainable elements and native or climate-appropriate flora compatible with local biomes.		✗
Category	Support	Considerations	Source(s)	Multiple Sources & Objectives
Sustainability & Climate Change Resiliency	All City Depts.	<p>1) Maximize benefits beyond stormwater management. 2) Assure projects follow standards using watershed approach (developed by LADWP) for landscaping. 3) Consider for all street programs, not just green streets. 4) Include BMPs that promote a wide range of benefits including: a) cooling and urban heat island b) trees that provide edible fruit (i.e.. Carob as allowed in City Standards). 5) Select flora that can survive extreme heat and prolonged drought. 6) Investigate Tucson, AZ program for resources. 7) Coordinate with Rec & Parks regarding pests that are invading Southern California. 8) Prioritize sustainable materials where possible.</p>	LASAN, Stakeholder Workshop, Project Workshop.	✓

Policy Number	Policy Lead	Policy Concept Language	Recommend to Water Cabinet
17	BOE, LASAN, LADWP, LADBS, LADOT	Create a process to expedite approval of public projects that help meet the Sustainable City pLAn, Watershed Management Programs, and One Water LA's objectives.	✓
Category	Support	Considerations	Source(s)
Improve Collaboration & Streamline Implementation	Water Cabinet	1) Develop steps to accomplish and identify all regulating agencies. 2) Collaborate with all agencies that have permitting authority to streamline permitting of stormwater capture projects. 3) Ensure that expedited process is subject to environmental laws. 4) Establish approval criteria and guidelines. 5) Work with BuildLA group	Steering Committee (LADOT, RAP), Stormwater STG, SCMP, Partnerships STG
			Multiple Sources & Objectives
			✓
Policy Number	Policy Lead	Policy Concept Language	Recommend to Water Cabinet
38	LASAN	Develop guidelines for Onsite Treatment Facilities (OSTFs) that protect public health and outline wastewater and recycled water systems' operation.	✗
Category	Support	Considerations	Source(s)
Recycled Water & On-Site Wastewater Treatment Facilities (private OSTF)	LADWP	Guideline development considerations: a) Using a geographic/sewershed approach for project evaluation that links project siting to system impacts and/or potable water use reduction. b) Exclusion of On-site Water Treatment Systems where purple pipe and a sufficient supply of recycled water is available. c) Prohibition of wastewater being taken or mined from LASAN sewers. d) Permit requirements including Industrial Wastewater Permits. e) Maintenance protocol to ensure proper design, operations, and maintenance that includes submission of Maintenance Plan with application and failure plan that assures safe disposal of all flows. f) Owner/operator liability (and possibly indemnify City) for injury, harm, penalties, fines, etc.. g) Neighbor notification of potential uses of OSTF's water onsite. h) Installation and maintenance of educational signage for projects using OSTF's water. i) Any necessary building code updates. j) Agreement with State AB 1463 Legislation guidelines. k) Guidelines should encourage innovation without diminishing revenues	Decentralized STG, LASAN, Project Workshop
			Multiple Sources & Objectives
			✗
Policy Number	Policy Lead	Policy Concept Language	Recommend to Water Cabinet
14	BSS	Update the Street Tree Selection Guide to better address climate change and water concerns.	✗
Category	Support	Considerations	Source(s)
Promote Integrated Planning & Design	LASAN, DCP	1) Carefully select trees that are drought tolerant, heat and pest resistant, and can capture stormwater in parkways. 2) Use as Reference Guide in Re:Code LA, Mitigation Measures and Community Plan updates. 3) Use list for sidewalk settlement tree replacements. 4) Expand the Urban Forestry list to include canopy trees (BSS) 5) Coordinate with certified arborists and licensed landscape architects.	LASAN, STG-Stormwater
			Multiple Sources & Objectives
			✓
Policy Number	Policy Lead	Policy Concept Language	Recommend to Water Cabinet
15	LASAN, LADWP	Identify a sufficient water supply for establishing and maintaining green infrastructure.	✗
Category	Support	Considerations	Source(s)
Improve Collaboration & Streamline Implementation	Water Cabinet	Establish a process to provide short and long-term water needs for each project.	Steering Committee (LASAN-WPD)
			Multiple Sources & Objectives
			✗

Policy Number	Policy Lead	Policy Concept Language		Recommend to Water Cabinet
5	LASAN	Develop robust stormwater pollution source control education measures that increase awareness and public participation.		✗
Category	Support	Considerations	Source(s)	Multiple Sources & Objectives
Stormwater and Urban Runoff - Preventive Stormwater Quality Improvement Measures	Public Works	1) Include multi-lingual public education program. 2) Address high pollutant activities like cleaning of painting and stucco equipment. 3) Increase safe centers and make them a one-stop site that includes compost, etc. 4) Include education for preventing runoff from industrial users. 5) Develop an education program on best types of lawn fertilizers to prevent nutrient pollution entering City storm drains. a) Include best practices for fertilizer application methods and timing. b) Promote organic lawn care education. c) Recognize and promote environmentally friendly products.	Project Workshop, Workshop #5	✓
Policy Number	Policy Lead	Policy Concept Language		Recommend to Water Cabinet
12	LASAN	Maximize opportunities to incorporate integrated water management strategies, including green infrastructure, into on-going and emerging opportunities.		✓
Category	Support	Considerations	Source(s)	Multiple Sources & Objectives
Promote Integrated Planning & Design	All City Depts., LACFCD, Other Regional Entities	Efforts include City of LA sidewalk repair program, Measure A grant guidelines, Measure M, Safe Routes to School, Metro's 1st and Last Mile, Active Transportation Projects and AHSC (Affordable Housing & Sustainable Communities) Program.	Project Workshop, Advisory Group, Stormwater Workshop, Steering Committee	✓
Policy Number	Policy Lead	Policy Concept Language		Recommend to Water Cabinet
6	BOE	Simplify the process and remove barriers to installing parkway swales and other distributed green infrastructure BMPs in the public		✓
Category	Support	Considerations	Source(s)	Multiple Sources & Objectives
Promote Integrated Planning & Design	LASAN, LAFD, BSS, DCP, LADOT	1) Create simplified standard plans for multiple BMPs including curb cuts, infiltration BMPs and permeable pavement (work with LAFD for permeable pavement). 2) Incorporate curb-cuts (or other water collection methods) and tree water wells to public right-of way tree planting projects where feasible. 3) Consider BMPs for sloped areas and areas where infiltration is not an option. 4) Create standards for appurtenances such as medians and roundabouts, curb extensions, and retro-fitting features such as tree well trenches. 5) Address design challenge when intersection is next to an existing storm drain. 6) Consider cost/affordability of permit(s). 7) Incorporate and share lessons-learned from project design and implementation in future designs. 8) Assure all city departments are aware of new and/or updated standards. 9) Include alleys in evaluation. 10) Coordinate with sidewalk repair program and Vision Zero goals.	Stormwater STG, Project Workshop, LASAN, Steering	✓

Policy Number	Policy Lead	Policy Concept Language		Recommend to Water Cabinet
9	LASAN	Develop templates for standardized maintenance agreements and provide training to ensure maintenance of collaborative stormwater projects in the City.		✗
Category	Support	Considerations	Source(s)	Multiple Sources & Objectives
Promote Integrated Planning & Design	All City Depts., Regional Agencies	Develop standardized agreements that can be shared across departments and organizations. Develop a training program that considers : 1) A certification program for BMP maintenance that can include the private sector. 2) Allowing the City to maintain improvements and BMPs constructed by smaller organizations. 3) An operations and maintenance cross-training program for dept./agencies/organizations on maintaining BMPs (former policy 74). 4) Consider modeling after Portland's Green Streets Stewards. Training should emphasize a watershed approach and should be consistent with the standards.	Steering Committee, LA Basin Study, Project Workshop	✓
Policy Number	Policy Lead	Policy Concept Language		Recommend to Water Cabinet
35	LASAN, LADWP	Expand education and engagement programs on potable reuse.		✗
Category	Support	Considerations	Source(s)	Multiple Sources & Objectives
Training and Education (revised heading)	None identified	1) Build on work completed by RWAG 2) Develop wider public education program that includes: a) Leverage resources by partnering with community colleges, and universities. b) develop materials appropriate for all grade levels. 3) Include training for City Supervisors and Counter Staff. 4) Identify resources to implement program. 5) Work with La Kretz Center on education programs.	Stakeholder Workshop (world café), Project Workshop, Workshop #5.	✓
Policy Number	Policy Lead	Policy Concept Language		Recommend to Water Cabinet
36	LASAN	Expand "how to" training and education programs to increase understanding of green infrastructure systems, increase implementation participation, and improve performance.		✗
Category	Support	Considerations	Source(s)	Multiple Sources & Objectives
Training and Education (revised heading)	All City Depts.	1) Increase practical training and education programs on: a) Best methods for onsite stormwater capture. b) Value of living soil for engineered soils. c) Selection and maintenance of Native Plants d) Provide technical assistance to match needs/issues for different land uses and bmps. e) Include methods Santa Monica Landscape Coaching Program. 2) Partner with academia to develop and deliver training and education programs 3) Determine priorities and time-frame for delivering programs. 4) Educate and train City Departments on MS4 and TMDL regulatory requirements. 5) Evaluate target audiences including landscape design, and landscape maintenance sectors for both workforce development and re-training of existing workforce.	Workshop #5.	✗

Policy Number	Policy Lead	Policy Concept Language	Recommend to Water Cabinet
28	LASAN, LADWP	Create a program to facilitate partnerships between City departments, regional agencies, and Non-Profit Organizations for water-related projects and programs.	✗
Category	Support	Considerations	Source(s)
Funding & Partnerships	All City Depts.	1) Involve neighborhood councils to connect partnerships to local needs. 2) Develop standard MOUs to streamline participation in projects. 3) Leverage NGOs with BMP expertise.	Funding STG (Top), Stormwater STG, SCMP, Workshop #5

Policy Number	Policy Lead	Policy Concept Language	Recommend to Water Cabinet
31	LASAN, LADWP	Expand partnerships between the City and academia to advance water-related research and innovation.	✗
Category	Support	Considerations	Source(s)
Funding & Partnerships	Academia	Increasing partnerships will leverage university and community college assets and resources while providing opportunities for academic growth and achievement. Increase partnerships and engagement with Universities, CSUs, and community colleges to: a) Advance research on water conservation, recycling and stormwater capture. b) Develop policies c) Provide third-party evaluation of policies and programs. d) Evaluate BMPs, impacts of different soils, and guide selection process.	Project Ideas, Workshop #5

Policy Number	Policy Lead	Policy Concept Language	Recommend to Water Cabinet
26	LASAN	Develop property owner recognition programs to promote and acknowledge stormwater capture retrofits and other sustainable practices.	✗
Category	Support	Considerations	Source(s)
Stormwater and Urban Runoff - Incentive Programs	LADWP	1) Develop property owner recognition programs including yard signage. 2) Create a business acknowledgement program for sustainable practices and explore how to incorporate into Green Business Certification Program. 3) Encourage “Riverly” development by highlighting public and private sector best practices for watershed management (SC). 4) Explore how to best involve state and federal agencies in cost-sharing.	Stormwater STG (Top), Steering Committee (LA River Works)

Quadrant 4: Higher Priority, More Difficult to Implement

Policy Number	Policy Lead	Policy Concept Language	Recommend to Water Cabinet
29	LASAN	Develop tools and best methods to facilitate agency cost-sharing for multi-benefit projects and programs.	✓
Category	Support	Considerations	Source(s)
Funding & Partnerships	All City Depts.	1) Create budgeting tool to identify multi-benefit projects and cost-sharing across multiple city departments, and regional agencies. 2) Leverage resources for multi-benefits 3) Develop a protocol to identify cost allocations using a benefit based cost-benefit analysis. 4) Explore how to best involve state and federal agencies in cost-sharing.	Living Streets, Partnerships STG, Steering Committee World Café, Funding STG (Top), Advisory Group SCMP. Workshop #5

Policy Number	Policy Lead	Policy Concept Language	Recommend to Water Cabinet
39	LASAN	Develop a fee structure and payment guidelines for on-site treatment systems that reflect collection and treatment system impacts and costs.	✗
Category	Support	Considerations	Source(s)
Recycled Water & On-Site Wastewater Treatment Facilities (private OSTF)	None identified	1) Determine surcharge or capacity related fee that Owners/Operators of OSTFs will pay to LASAN 2) Structure fee so that existing customers do not have to subsidize, directly or indirectly, the capital cost or operations of OSTFs. 3) Surcharge Fees structure could include a tiered rate for solids, total dissolved solids (TDS) limit in the Sewer Use Ordinance, which would apply to all users, or a TDS limit in each discharge permit for industrial users. 4) Include cost recovery for salt or TDS concentration impacts.	Decentralized STG, LASAN
			Multiple Sources & Objectives
			✓
Policy Number	Policy Lead	Policy Concept Language	Recommend to Water Cabinet
21	LASAN	Develop a protocol for when and how private property owners will maintain the City's right-of-way stormwater improvements.	✗
Category	Support	Considerations	Source(s)
Improve Collaboration & Streamline Implementation	BOE, BSS, LADWP	Include a mechanism to ensure/enforce maintenance.	Stormwater Facilities Workshop
			Multiple Sources & Objectives
			✓
Policy Number	Policy Lead	Policy Concept Language	Recommend to Water Cabinet
32	Mayor's Office	Integrate climate adaptation, mitigation, and resilience principles into the planning, design, construction, and operations of water-related projects.	✓
Category	Support	Considerations	Source(s)
Sustainability & Climate Change Resiliency	All City Depts.	1) Carefully consider selection of climate change models to consider climate scenarios. 2) Prioritize life-cycle performance of components, systems, and materials. 3) Reference work already taking place including Green Building Council and California Building codes. 4) Expand water-efficient practices at all City facilities. a) Expand to watershed/LID approach to capture more stormwater where possible. b) Work with City agencies including with LADOT and BOE on ROW's like the Los Angeles River Bike Path. c) Install or retrofit City properties with efficient irrigation and Smart Controllers. d) Include daily operational practices (ex. using recycled water for street sweeping trucks). e) Use drought-tolerant, heat resistant plants wherever feasible.	Steering Committee (HSR, LACFCD, LADOT, LADWP), Workshop #5
			Multiple Sources & Objectives
			✓

Policy Number	Policy Lead	Policy Concept Language		Recommend to Water Cabinet
19	BSS, BOE, DCP	Identify the process or entity that will coordinate and manage all street and alley improvement efforts in the City.		✓
Category	Support	Considerations	Source(s)	Multiple Sources & Objectives
Improve Collaboration & Streamline Implementation	DOT, LADWP, LASAN	Recommended to maximize integration opportunities and leverage existing resources. 1) Build upon LASAN's Public Right-of-Way LID group 2) Include all street programs including Green, Complete, People, Living, Cool, Clean, Great, etc. 3) Include Mobility Plan and Vision Zero goals. 4) Develop co-benefit approach and consider checklist that would include goals from each program. 5) Create a framework/process to identify prospective multi-jurisdictional projects. 6) Convene a committee to discuss process and next steps.	Living Streets; Stormwater STG, Project Workshop, Steering Committee	✓
Policy Number	Policy Lead	Policy Concept Language		Recommend to Water Cabinet
16	LASAN, LADWP	Create a vehicle that allows for shared operation and maintenance duties between multiple public agencies or public/private entities for stormwater BMPs.		✗
Category	Support	Considerations	Source(s)	Multiple Sources & Objectives
Improve Collaboration & Streamline Implementation	Water Cabinet, All City Depts.	1) Convene task force or committee to explore structures and make recommendations. 2) Consider JPAs as potential vehicle for maintenance and operations for public entities.	Stormwater STG (Top)	✓
Policy Number	Policy Lead	Policy Concept Language		Recommend to Water Cabinet
22	LASAN	Evaluate and implement the most effective methods to incentivize stormwater capture retrofits.		✗
Category	Support	Considerations	Source(s)	Multiple Sources & Objectives
Stormwater and Urban Runoff - Incentive Programs	LADWP	Ideas suggested to evaluate: 1) Stormwater fee credit or discount program. a) Incentives program should include opportunities for all property types including single family, multi-family, schools, commercial, industrial and municipal. b) Create credits for those who capture more current regulation requirements. c) Fee waivers or reductions for homes with zero runoff. d) Credits or fee waivers in exchange for long-term rights to construct capture and infiltration or capture and use projects under playgrounds and sports fields. e) Consider credits for past performance. 2) Develop engagement program to: a) Educate property owners about available incentives and retrofit methods. b) Consider method that encourages neighbors to self-organize to trigger enhanced group incentive. c) Include Neighborhood Councils in promotional efforts. 3) Include rebates for a variety of bmps including French drains and rain gardens. 4) Identify a funding source for Incentive Programs.	Steering Committee, Stakeholder Workshop (world café), Funding STG, Coalition for our Water Future, SCMP, Stormwater STG (Top), Project Workshop, Workshop #5	✓

Policy Number	Policy Lead	Policy Concept Language		Recommend to Water Cabinet
7	LADBS	Simplify the process and remove barriers to installing distributed green infrastructure BMPs on private properties in the City.		✗
Category	Support	Considerations	Source(s)	Multiple Sources & Objectives
Promote Integrated Planning & Design	LASAN, BOE, DCP, Regional Agencies	Develop additional design guidance for on-site infiltration and direct use projects: 1) Ensure that policy addresses design needs of different types of properties. 2) Factor in soil absorption capacity in designs, not just infiltration rates (LADBS Grading Division). 3) Address building codes that are a hindrance including diversion distance requirements for downspout redirects. 4) Untangle/simplify regulations for rainwater harvesting. Involve LADBS Mechanical Division and LA County Dept. of Public Health. 5) Consider cost of implementation as a potential barrier.	Various (at least 2), LASAN, Workshop 5, Steering	✓
Policy Number	Policy Lead	Policy Concept Language		Recommend to Water Cabinet
23	LASAN	Develop incentive programs to encourage reducing paved areas and increasing permeable pavements.		✗
Category	Support	Considerations	Source(s)	Multiple Sources & Objectives
Stormwater and Urban Runoff - Incentive Programs	BOE, LADWP	1) Create a rebate program for private parking lot retrofits for pervious pavement and stormwater recapture/infiltration improvements. 2) Include tree canopy in parking lot retrofits. 3) Include schools in the program. 4) Investigate pervious pavement programs implemented by Watsonville, CA and Philadelphia. 5) Explore pervious buy-back program or pervious rebate for reducing impermeable parking lots, driveways, etc. 6) Base rebate amount on benefit received. 7) Determine thresholds for implementing incentives including property size, building footprint, and square footage reduction requirements.	Stormwater STG (Cons. # 5 Top Recc)	✗
Policy Number	Policy Lead	Policy Concept Language		Recommend to Water Cabinet
27	LASAN, LADWP	Create a program to evaluate and facilitate public-private partnerships for water projects.		✓
Category	Support	Considerations	Source(s)	Multiple Sources & Objectives
Funding & Partnerships	All City Depts.	1) Evaluate most cost effective incentives to foster partnerships with investors and private companies for capital projects. 2) Develop a public process to determine: a) criteria to identify best opportunities for P3s b) rewards; bids/award process. c) Financing vehicles. 3) Include Unions, and Clean Tech Incubator to help cultivate startups.	Funding STG (Top), Partnerships STG, Advisory Group, SCMP, Workshop #5	✓

Policy Number	Policy Lead	Policy Concept Language	Recommend to Water Cabinet	
2	LASAN	Research best method and establish tracking system for graywater installations throughout the city. Consider potential impacts of graywater systems on water supply needs.	✗	
Category	Support	Considerations	Source(s)	Multiple Sources & Objectives
Water Conservation & Graywater	LADWP, LADBS	Conduct research to gather more local data on graywater usage and impacts. 1) Develop tracking method for graywater system installations. 2) Determine best way to accommodate onsite facilities while protecting/balancing financial and flow impacts. 3) Consider potential conflicts between expanded graywater use and future IPR/DPR programs. 4) Ammonia and TDS are important to track.	Decentralized STG, Steering Committee	✓
Policy Number	Policy Lead	Policy Concept Language	Recommend to Water Cabinet	
3	LADBS, LASAN, LADWP	Develop graywater user education information and signage for areas irrigated with graywater.	✗	
Category	Support	Considerations	Source(s)	Multiple Sources & Objectives
Water Conservation & Graywater	County Health	1) Provide information on proper detergent use to address the accumulation of salts in soil from graywater, which has a negative effect soil biology and plants. 2) Provide education on proper use of graywater to maximize graywater system efficiency. 3) Review Arizona policy as possible model for education. 4) Use consistent signage for recycled water and graywater and consider recycled materials for signage. 5) Consider how graywater system information will be transferred with home ownership transfer.	Decentralized STG	✗
Policy Number	Policy Lead	Policy Concept Language	Recommend to Water Cabinet	
25	LASAN	Evaluate the feasibility of a program that allows properties to generate Stormwater Retention Credits (SRCs) for voluntary implementation of green infrastructure that reduces stormwater runoff.	✗	
Category	Support	Considerations	Source(s)	Multiple Sources & Objectives
Stormwater and Urban Runoff - Incentive Programs	LADWP	Evaluate Washington program similar to cap and trade	Stormwater STG (Top)	✗

Quadrant 1: Lower Priority, Easier to Implement				
No policies listed in quadrant 1.				
Quadrant 3: Lower Priority, More Difficult to Implement				
Policy Number	Policy Lead	Policy Concept Language		Recommend to Water Cabinet
34	BOE	Explore the feasibility of requiring the Sustainable Infrastructure Certification program Envision for large projects and create a program for staff certification.		✘
Category	Support	Considerations	Source(s)	Multiple Sources & Objectives
Sustainability & Climate Change Resiliency	All City Depts.	1) Develop criteria for requiring certification. BOE recommends setting up a subgroup of interested parties include BOS, DOT and Metro. 2)BOE to consider prioritizing Envision points for Quality of Life, Leadership, Resource Allocation, Natural World and Climate and Risk during preliminary design & construction of City facilities. 3) Include as part of the design process.	Steering Committee (BOE)	✔
Policy Number	Policy Lead	Policy Concept Language		Recommend to Water Cabinet
30	LASAN	Explore the potential for establishing an Enhanced Infrastructure Financing District or other appropriate funding mechanism to fund capital projects and sustainable operations and maintenance.		✘
Category	Support	Considerations	Source(s)	Multiple Sources & Objectives
Funding & Partnerships	Mayor's Office (LA RiverWorks, City Services, and Economic Development)	Consider LA River Revitalization Projects as a priority opportunity.	Steering Committee (LA Riverworks)	✘
Policy Number	Policy Lead	Policy Concept Language		Recommend to Water Cabinet
24	LASAN	Create a "Percent for Green" fund that supports constructing Green Street facilities and dedicate a minimum percent for green infrastructure.		✘
Category	Support	Considerations	Source(s)	Multiple Sources & Objectives
Stormwater and Urban Runoff - Incentive Programs	All City Depts.	1) Develop a science-based framework for evaluating eligible projects. 2) Consider as a funding source for Community Grant Projects.	Stormwater STG (Top)	✔
Policy Number	Policy Lead	Policy Concept Language		Recommend to Water Cabinet
13	LASAN	Investigate the development of a stormwater capture retrofit ordinance that would require installing stormwater capture projects in homes upon resale.		✘
Category	Support	Considerations	Source(s)	Multiple Sources & Objectives
Promote Integrated Planning & Design	TBD	1) Consider major redevelopment, not just resale. 2) Explore how to transfer BMP requirement to subsequent owners. 3) Consider cost of implementation and any off-set by rebate programs.	SCMP	✔

Policy Number	Policy Lead	Policy Concept Language		Recommend to Water Cabinet
1	LADBS	Update efficiency requirements in City's retrofit on resale program.		✘
Category	Support	Considerations	Source(s)	Multiple Sources & Objectives
Water Conservation & Graywater	LASAN, LADWP	1) Update efficiency requirements to match more stringent current standards set in the City's other plumbing fixture efficiency ordinances. 2) Consider additional water-using appliances (urinals, showers, laundry) 3) Commercial/Industrial properties and high water uses like hospitals and large cooling systems.	LASAN	✘
Policy Number	Policy Lead	Policy Concept Language		Recommend to Water Cabinet
4	LASAN	Develop best method to encourage drainage water from swimming pools to be discharged into the sewer system rather than a street or storm drain.		✘
Category	Support	Considerations	Source(s)	Multiple Sources & Objectives
Stormwater and Urban Runoff - Preventive Stormwater Quality Improvement Measures	LADWP, GSD, RAP, and others	1) Develop guidelines with instructions for how customers will connect and report. 2) Explain if/how discharge will effect the sewer service charge. 3) Consider requiring a no-cost permit for pool discharge to assist with quantifying water volume. 4) Address allowances for customers without sewer clean out access.	LASAN	✘
Policy Number	Policy Lead	Policy Concept Language		Recommend to Water Cabinet
37	BOE	Develop BMP training and certification programs for construction industry and landscape professionals.		✘
Category	Support	Considerations	Source(s)	Multiple Sources & Objectives
Training and Education (revised heading)	LASAN	1) Create training/certification programs for contractors and other professionals to : Improve understanding of green infrastructure to address disconnect between design and construction. Include performance monitoring program identify gaps and measure success. Consider LA Trade Tech for testing and implementation of BMPs including swales, cisterns. 2) Develop a BMP training/certification program in community colleges to retrain landscape workforce on in proper landscape techniques for water conservation and stormwater capture. 3) Deliver education programs at both high school and university level.	Workshop #5.	✔



carollo
Engineers...Working Wonders With Water®

in collaboration with

 **Stantec**

Geosyntec
consultants

**CDM
Smith**

ch2m:

KATZ
& Associates

M2 Resource Consulting, Inc.