



ONE WATER LA 2040 PLAN

VOLUME 2 Wastewater Facilities Plan

FINAL DRAFT | APRIL 2018



CITY OF LOS ANGELES

ONE WATER LA 2040 PLAN

VOLUME 2 Wastewater Facilities Plan

FINAL DRAFT • APRIL 2018

This document is released for the purpose of information exchange review and planning only under the authority of Sarah Munger • April 30, 2018
State of California • PE License No. 72102



IN COLLABORATION WITH:



SUMMARY OF ONE WATER LA

The One Water LA 2040 Plan (Plan) takes a holistic and collaborative approach to consider all of the City's water resources from surface water, groundwater, potable water, wastewater, recycled water, dry-weather runoff, and stormwater as "One Water." The Plan also identifies multi-departmental and multi-agency integration opportunities to manage water in a more efficient, cost effective, and sustainable manner. The Plan represents the City's continued and improved commitment to proactively manage all its water resources and implement innovative solutions, driven by the Sustainable City pLAn. The Plan will help guide strategic decisions for integrated water projects, programs, and policies within the City.



PLAN ORGANIZATION

The One Water LA 2040 Plan consists of the following ten volumes:

- VOLUME 1 - Summary Report
- VOLUME 2 - Wastewater Facilities Plan
- VOLUME 3 - Stormwater and Urban Runoff Facilities Plan
- VOLUME 4 - LA River Flow Study
- VOLUME 5 - Integration Opportunities Analysis Details
- VOLUME 6 - Climate Risk & Resilience Assessment for Wastewater and Stormwater Infrastructure
- VOLUME 7 - Implementation Strategy Supporting Documents
- VOLUME 8 - Technical Support Materials
- VOLUME 9 - Stakeholder Engagement Materials
- VOLUME 10 - Programmatic Environmental Impact Report

The information presented in this Wastewater Facilities Plan (Volume 2) is also summarized in Chapter 7 of the Summary Report (Volume 1). In addition, supporting documents of the information presented herein are included in:

- TM 1.2 - Existing Flow Conditions (Volume 8)
- TM 2.1 - Future Flow Conditions (Volume 8)
- TM 5.2 - Future Concepts Development (Volume 5)
- TM 5.5 - Climate Risk & Resilience Assessment for Wastewater and Stormwater Infrastructure (Volume 6)
- TM 12.5.1 through TM 12.5.3 - Onsite Treatment Evaluations (Volume 8)
- Informational Stakeholder Meeting materials presented on 5/11/2017 (Volume 9)

VOLUME 2 OVERVIEW & ORGANIZATION

An overview of information presented in this volume is provided in the table below.

| Chapter No. and Name | | Content Overview |
|----------------------|----------------------------------------------|-------------------------------------------------------------------------------------------------------------------------------------------------------------------------------------------------------------------------------|
| ES | Executive Summary | Executive summary to the entire volume that focuses on key findings, conclusions, and recommendations/strategies. |
| 1 | Introduction | Discusses the purpose of the WWFP, planning documents used, and the organization of the plan. |
| 2 | Basis of Planning | Establishes the study area, provides an overview of flow projections and hydraulic modeling, describes water reuse options, potential future regulations, and design and sizing criteria assumptions used for the evaluation. |
| 3 | Wastewater Collection System | Provides an overview of the City's existing collection system, and planned major projects. |
| 4 | Hyperion Water Reclamation Plant | Discusses Hyperion Water Reclamation Plant's existing treatment facilities and current performance, projected wastewater flows to the plant, planned and in-progress projects, and potential future concept options. |
| 5 | Donald C. Tillman Water Reclamation Plant | Discusses Donald C. Tillman Water Reclamation Plant's existing treatment facilities and current performance, projected wastewater flows to the plant, in-progress projects, and potential future concept options. |
| 6 | Los Angeles-Glendale Water Reclamation Plant | Discusses Los Angeles-Glendale Water Reclamation Plant's existing treatment facilities and current performance, projected wastewater flows to the plant, and potential future concept options. |

| Chapter No. and Name | | Content Overview |
|-----------------------------|----------------------------------------------------------------------|-----------------------------------------------------------------------------------------------------------------------------------------------------------------------------------------------------------------------------------------------------------------|
| 7 | Terminal Island Water Reclamation Plant | Discusses Terminal Island Water Reclamation Plant's existing treatment facilities and current performance, projected wastewater flows to the plant, planned projects, and potential future concept options. |
| 8 | Potential Future Water Reclamation Projects | Expands on the option of potential future water reclamation plants to provide on-site treatment for smaller service areas. |
| 9 | Biosolids Handling | Provides an overview of existing biosolids management, existing biosolids production at Hyperion Water Reclamation Plant and Terminal Island Water Reclamation Plant, summary of biosolids technologies, and recommendations for future biosolids management. |
| 10 | Climate Risk and Resilience Assessment for Wastewater Infrastructure | Evaluates the climate risk and resilience for the collection system and water reclamation plants. This chapter also provides suggested projects to adapt and mitigate to changing climate conditions. |
| 11 | Wastewater Facilities Adaptive Capital Improvement Plan | Presents a capital improvement plan for the collection system and water reclamation plants based on timing and project type. This adaptive Capital Improvement Plan is combined with an evaluation of potential projects to yield total estimates for the City. |
| Appendices | | Provides supporting materials. |

-This Page Left Blank Intentionally-

CITY OF LOS ANGELES

VOLUME 2: WASTEWATER FACILITIES PLAN

TABLE OF CONTENTS

Page No.

EXECUTIVE SUMMARY

| | | |
|------|---------------------------------------------------------------|-------|
| ES.1 | WASTEWATER FACILITY PLAN PURPOSE | ES-1 |
| ES.2 | BASIS OF PLANNING | ES-2 |
| | ES.2.1 Wastewater System Service Area | ES-3 |
| | ES.2.2 Wastewater Flow Projections | ES-7 |
| | ES.2.3 Non-Potable Reuse | ES-10 |
| | ES.2.4 Potable Reuse | ES-10 |
| | ES.2.5 Regulatory Drivers | ES-11 |
| ES.3 | WASTEWATER COLLECTION SYSTEM | ES-13 |
| | ES.3.1 Existing Collection System | ES-13 |
| | ES.3.2 Near-Term Planned Collection System Improvements | ES-13 |
| | ES.3.3 Long-Term Collection System Improvements | ES-14 |
| ES.4 | WATER RECLAMATION PLANTS | ES-14 |
| | ES.4.1 HWRP | ES-15 |
| | ES.4.2 DCTWRP | ES-18 |
| | ES.4.3 LAGWRP | ES-20 |
| | ES.4.4 TIWRP | ES-23 |
| ES.5 | FUTURE WASTEWATER SYSTEM ANALYSIS | ES-25 |
| | ES.5.1 HWRP | ES-26 |
| | ES.5.2 DCTWRP | ES-34 |
| | ES.5.3 LAGWRP | ES-41 |
| | ES.5.4 TIWRP | ES-48 |
| | ES.5.5 Potential Future Water Reclamation Plant Options | ES-49 |
| | ES.5.6 On-Site Treatment | ES-49 |
| ES.6 | BIOSOLIDS MANAGEMENT | ES-50 |
| ES.7 | CLIMATE RISK ASSESSMENT FOR WASTEWATER INFRASTRUCTURE ... | ES-51 |
| ES.8 | WASTEWATER FACILITIES ADAPTIVE CAPITAL IMPROVEMENT PLAN ... | ES-52 |
| | ES.8.1 Cost Estimating Assumptions | ES-52 |
| | ES.8.2 CIP Planning Phases and Project Categories | ES-53 |
| | ES.8.3 In-Progress Projects | ES-54 |
| | ES.8.4 Current Integration Opportunities | ES-55 |
| | ES.8.5 Future Integration Opportunities | ES-55 |
| | ES.8.6 Estimated and Projected CIP Summary | ES-56 |
| | ES.8.7 WWFP Adaptive CIP | ES-57 |
| | ES.8.8 Escalated CIP | ES-60 |

CHAPTER 1 – INTRODUCTION

| | | |
|-----|-----------------------------------------------|-----|
| 1.1 | BACKGROUND | 1-1 |
| 1.2 | WASTEWATER FACILITY PLAN PURPOSE | 1-2 |
| 1.3 | PREVIOUS PLANNING DOCUMENTS AND STUDIES | 1-2 |
| 1.4 | WASTEWATER FACILITY PLAN ORGANIZATION | 1-3 |

| | | |
|-----|------------------------|-----|
| 1.5 | ACKNOWLEDGEMENTS | 1-5 |
|-----|------------------------|-----|

CHAPTER 2 – BASIS OF PLANNING

| | | |
|-------|--------------------------------------------------------------|------|
| 2.1 | WASTEWATER SYSTEM SERVICE AREA..... | 2-1 |
| 2.1.1 | Existing Collection System and Water Reclamation Plants..... | 2-3 |
| 2.2 | WASTEWATER FLOW PROJECTIONS | 2-3 |
| 2.2.1 | Methodology | 2-3 |
| 2.2.2 | Historical and Existing Flows..... | 2-3 |
| 2.2.3 | Future Wastewater Flows Summary..... | 2-4 |
| 2.3 | WASTEWATER REUSE OPTIONS | 2-8 |
| 2.3.1 | Non-Potable Reuse..... | 2-8 |
| 2.3.2 | Potable Reuse..... | 2-8 |
| 2.4 | REGULATORY DRIVERS..... | 2-10 |
| 2.5 | DESIGN AND SIZING CRITERIA | 2-14 |
| 2.5.1 | Collection System | 2-14 |
| 2.5.2 | Water Reclamation Plants..... | 2-15 |

CHAPTER 3 – WASTEWATER COLLECTION SYSTEM

| | | |
|-------|---------------------------------------------------------------|------|
| 3.1 | EXISTING COLLECTION SYSTEM | 3-1 |
| 3.1.1 | Collection System Overview..... | 3-1 |
| 3.1.2 | HSA Collection System | 3-4 |
| 3.1.3 | TISA Collection System..... | 3-8 |
| 3.1.4 | Low Flow Diversion Structures | 3-11 |
| 3.2 | PLANNED COLLECTION SYSTEM PROJECTS | 3-12 |
| 3.2.1 | LAGWRP Primary Effluent Equalization Storage..... | 3-13 |
| 3.2.1 | North Outfall Sewer Rehabilitation..... | 3-13 |
| 3.2.2 | Venice Pumping Plant Dual Force Main | 3-13 |
| 3.2.3 | Venice Auxiliary Pumping Plant..... | 3-14 |
| 3.3 | CONCEPTUAL CAPITAL IMPROVEMENT PROJECTS..... | 3-15 |
| 3.3.1 | East-West Valley Interceptor Sewer (EWVIS) | 3-15 |
| 3.3.2 | San Fernando Relief Sewer | 3-15 |
| 3.4 | CLIMATE RISK AND RESILIENCE ASSESSMENT..... | 3-16 |
| 3.5 | COLLECTION SYSTEM ADAPTIVE CIP | 3-16 |
| 3.5.1 | Collection System Estimated CIP..... | 3-17 |
| 3.5.2 | Collection System Adaptive CIP Net Present Worth Summary..... | 3-19 |

CHAPTER 4 – HYPERION WATER RECLAMATION PLANT

| | | |
|--------|----------------------------------------------------------------------|------|
| 4.1 | EXISTING TREATMENT PROCESS DESCRIPTION | 4-1 |
| 4.1.1 | Treatment Process Overview | 4-4 |
| 4.1.2 | Influent Flows and Characteristics..... | 4-6 |
| 4.1.3 | Effluent Flows and Characteristics | 4-6 |
| 4.1.4 | Process Descriptions..... | 4-7 |
| 4.1.5 | Preliminary Treatment..... | 4-8 |
| 4.1.6 | Primary Treatment | 4-11 |
| 4.1.7 | Intermediate Pump Station | 4-13 |
| 4.1.8 | Secondary Treatment - High Purity Oxygen Generation Facilities | 4-14 |
| 4.1.9 | Secondary Treatment – Reactors, Clarifiers and Pumping | 4-17 |
| 4.1.10 | Effluent Discharge System | 4-22 |
| 4.1.11 | Solids Processing..... | 4-25 |
| 4.1.12 | Digester Gas Handling and Power Generation Facilities | 4-30 |

| | | |
|--------|--------------------------------------------------------------------------------------------|------|
| 4.1.13 | Ancillary Facilities..... | 4-32 |
| 4.1.14 | Recent and Ongoing Plant Upgrades..... | 4-36 |
| 4.2 | IN-PROGRESS PROJECTS..... | 4-40 |
| 4.2.1 | Advanced Treated Recycled Water Delivery to LAX and Scattergood Generating Station..... | 4-41 |
| 4.2.2 | HWRP Delivery Expansion to 70 mgd for WBMWD and LA Harbor Area..... | 4-47 |
| 4.3 | FUTURE SYSTEM NEEDS EVALUATION..... | 4-50 |
| 4.3.1 | Flow Evaluation..... | 4-50 |
| 4.3.2 | Concept Options Development..... | 4-53 |
| 4.3.3 | Preferred Approach..... | 4-55 |
| 4.3.4 | Concept Option #13 (MBR at HWRP to Regional System)..... | 4-57 |
| 4.4 | CLIMATE RISK AND RESILIENCE ASSESSMENT..... | 4-61 |
| 4.5 | HWRP ADAPTIVE CIP..... | 4-62 |
| 4.5.1 | HWRP In-Progress Projects..... | 4-63 |
| 4.5.2 | HWRP Concept Options..... | 4-64 |
| 4.5.3 | HWRP Estimated and Projected CIP..... | 4-64 |
| 4.5.4 | HWRP Adaptive CIP Summary..... | 4-66 |
| 4.5.5 | HWRP Adaptive CIP Net Present Worth Summary..... | 4-69 |

CHAPTER 5 – DONALD C. TILLMAN WATER RECLAMATION PLANT

| | | |
|--------|------------------------------------------------------------------|------|
| 5.1 | EXISTING TREATMENT PROCESS DESCRIPTION..... | 5-1 |
| 5.1.1 | Treatment Process Overview..... | 5-4 |
| 5.1.2 | Influent Flow and Characteristics..... | 5-4 |
| 5.1.3 | Effluent Flows and Characteristics..... | 5-6 |
| 5.1.4 | Process Description..... | 5-6 |
| 5.1.5 | Preliminary Treatment..... | 5-7 |
| 5.1.6 | Primary Treatment..... | 5-9 |
| 5.1.7 | Secondary Treatment..... | 5-12 |
| 5.1.8 | Tertiary Treatment..... | 5-19 |
| 5.1.9 | Disinfection..... | 5-20 |
| 5.1.10 | Dechlorination..... | 5-22 |
| 5.1.11 | Effluent Water Reuse..... | 5-23 |
| 5.1.12 | Ancillary Facilities..... | 5-24 |
| 5.1.13 | Recent and Ongoing Plant Upgrades..... | 5-24 |
| 5.2 | IN-PROGRESS PROJECT..... | 5-27 |
| 5.2.1 | Project Description..... | 5-28 |
| 5.3 | FUTURE SYSTEM NEEDS EVALUATION..... | 5-30 |
| 5.3.1 | Flow Evaluation..... | 5-30 |
| 5.3.2 | Concept Options Development..... | 5-34 |
| 5.3.3 | Preferred Approach..... | 5-36 |
| 5.3.4 | Concept Option #15 (DCTWRP to LA Aqueduct Filtration Plant)..... | 5-39 |
| 5.3.5 | Concept Option #22 (East West Valley Interceptor Sewer)..... | 5-44 |
| 5.4 | CLIMATE RISK AND RESILIENCE ASSESSMENT..... | 5-47 |
| 5.5 | DCTWRP ADAPTIVE CIP..... | 5-47 |
| 5.5.1 | DCTWRP In-Progress Projects..... | 5-49 |
| 5.5.2 | DCTWRP Concept Options..... | 5-50 |
| 5.5.3 | DCTWRP Estimated and Projected CIP..... | 5-50 |
| 5.5.4 | DCTWRP Adaptive CIP Summary..... | 5-53 |
| 5.5.5 | DCTWRP Adaptive CIP Net Present Worth Summary..... | 5-55 |

CHAPTER 6 – LOS ANGELES-GLENDALE WATER RECLAMATION PLANT

| | | |
|--------|----------------------------------------------------------|------|
| 6.1 | EXISTING TREATMENT PROCESS DESCRIPTION | 6-1 |
| 6.1.1 | Treatment Process Overview | 6-4 |
| 6.1.2 | Influent Flow and Characteristics..... | 6-4 |
| 6.1.3 | Effluent Flow and Characteristics | 6-6 |
| 6.1.4 | Process Descriptions..... | 6-6 |
| 6.1.5 | Preliminary Treatment | 6-8 |
| 6.1.6 | Primary Treatment | 6-10 |
| 6.1.7 | Secondary Treatment..... | 6-12 |
| 6.1.8 | Tertiary Treatment..... | 6-18 |
| 6.1.9 | Disinfection | 6-21 |
| 6.1.10 | Dechlorination | 6-23 |
| 6.1.11 | Effluent Water Reuse | 6-24 |
| 6.1.12 | Ancillary Facilities..... | 6-25 |
| 6.1.13 | Recent and Ongoing Plant Upgrades | 6-25 |
| 6.2 | IN-PROGRESS PROJECT | 6-27 |
| 6.3 | FUTURE SYSTEM NEEDS EVALUATION | 6-28 |
| 6.3.1 | Flow Evaluation..... | 6-28 |
| 6.3.2 | Concept Options Development..... | 6-32 |
| 6.3.3 | Preferred Approach..... | 6-32 |
| 6.3.4 | Concept Option #17 (LAGWRP to Headworks Reservoir) | 6-35 |
| 6.4 | CLIMATE RISK AND RESILIENCE ASSESSMENT..... | 6-40 |
| 6.5 | LAGWRP ADAPTIVE CIP | 6-41 |
| 6.5.1 | LAGWRP In-Progress Projects | 6-43 |
| 6.5.2 | LAGWRP Concept Options | 6-43 |
| 6.5.3 | LAGWRP Estimated and Projected CIP | 6-44 |
| 6.5.4 | LAGWRP Adaptive CIP Summary..... | 6-46 |
| 6.5.5 | LAGWRP Adaptive CIP Net Present Worth Summary..... | 6-48 |

CHAPTER 7 – TERMINAL ISLAND WATER RECLAMATION PLANT

| | | |
|--------|----------------------------------------------|------|
| 7.1 | EXISTING TREATMENT PROCESS DESCRIPTION | 7-1 |
| 7.1.1 | Treatment Process Overview | 7-4 |
| 7.1.2 | Influent Flows and Characteristics..... | 7-6 |
| 7.1.3 | Effluent Flows and Characteristics | 7-6 |
| 7.1.4 | Process Descriptions..... | 7-8 |
| 7.1.5 | Preliminary Treatment | 7-9 |
| 7.1.6 | Primary Treatment | 7-11 |
| 7.1.7 | Secondary Treatment..... | 7-13 |
| 7.1.8 | Tertiary Treatment..... | 7-18 |
| 7.1.9 | Advanced Water Purification Facility | 7-21 |
| 7.1.10 | Effluent Discharge System | 7-27 |
| 7.1.11 | Solids Processing..... | 7-28 |
| 7.1.12 | Sidestreams | 7-32 |
| 7.1.13 | In Plant Storm Drains | 7-33 |
| 7.1.14 | Ancillary Facilities..... | 7-35 |
| 7.1.15 | Recent Plant Upgrades | 7-35 |
| 7.2 | IN-PROGRESS PROJECTS | 7-36 |
| 7.3 | FUTURE SYSTEM NEEDS EVALUATION | 7-40 |
| 7.3.1 | Flow Evaluation..... | 7-40 |
| 7.3.2 | Concept Option Development | 7-46 |

| | | |
|-------|---------------------------------------------------|------|
| 7.4 | CLIMATE RISK AND RESILIENCE ASSESSMENT | 7-48 |
| 7.5 | TIWRP ADAPTIVE CIP..... | 7-48 |
| 7.5.1 | TIWRP In-Progress Projects | 7-50 |
| 7.5.2 | TIWRP Estimated and Projected CIP | 7-51 |
| 7.5.3 | TIWRP Adaptive CIP Summary..... | 7-53 |
| 7.5.4 | TIWRP Adaptive CIP Net Present Worth Summary..... | 7-54 |

CHAPTER 8 – POTENTIAL FUTURE WATER RECLAMATION PLANTS

| | | |
|-------|----------------------------------------------|-----|
| 8.1 | ON-SITE TREATMENT EVALUATIONS SUMMARY | 8-1 |
| 8.1.1 | Evaluation of Impacts | 8-2 |
| 8.1.2 | Policy Recommendations..... | 8-2 |
| 8.2 | RANCHO PARK WATER RECLAMATION FACILITY | 8-3 |
| 8.3 | FLOW ROUTING CHANGES AND IMPACT | 8-5 |
| 8.3.1 | Flow routing to the new WRP..... | 8-5 |

CHAPTER 9 – BIOSOLIDS MANAGEMENT

| | | |
|-----|---------------------------------------------------------------------------------------|-----|
| 9.1 | IMPORTANCE OF CONSIDERING BIOSOLIDS IN WATER IRP AND ONE WATER LA | 9-1 |
| 9.2 | EXISTING BIOSOLIDS MANAGEMENT | 9-1 |
| 9.3 | SOLIDS PRODUCTION..... | 9-2 |
| 9.4 | DRIVERS AFFECTING BIOSOLIDS MANAGEMENT..... | 9-4 |
| 9.5 | FUTURE BIOSOLIDS MANAGEMENT | 9-5 |
| 9.6 | INTRODUCTION AND PRE-SCREENING OF PRODUCT TECHNOLOGIES (BIOSOLIDS TECHNOLOGIES) | 9-6 |
| 9.7 | RECOMMENDATIONS..... | 9-7 |

CHAPTER 10 – CLIMATE RISK AND RESILIENCE ASSESSMENT FOR WASTEWATER INFRASTRUCTURE

| | | |
|--------|---------------------------------------------------------|-------|
| 10.1 | METHODOLOGY..... | 10-3 |
| 10.2 | PUMPING PLANT AND LOW FLOW DIVERSIONS ASSESSMENT | 10-3 |
| 10.2.1 | Wastewater Pumping Plants | 10-4 |
| 10.2.2 | Low Flow Diversions | 10-9 |
| 10.2.3 | Improvements Summary and Prioritization | 10-11 |
| 10.3 | COLLECTION SYSTEM RISK AND RESILIENCE ASSESSMENT..... | 10-11 |
| 10.3.1 | West LA Primary Sewer Basin | 10-12 |
| 10.3.2 | Climate Change Scenario | 10-12 |
| 10.3.3 | Hydraulic Modeling Analysis | 10-15 |
| 10.3.4 | Observations and Recommendations..... | 10-16 |
| 10.4 | FLOOD HAZARD ASSESSMENT | 10-17 |
| 10.5 | POWER SUPPLY AND BACKUP POWER GENERATION..... | 10-19 |
| 10.6 | FIRE AND LANDSLIDE ASSESSMENT | 10-19 |
| 10.7 | SALT WATER INTRUSION ASSESSMENT | 10-20 |
| 10.8 | WATER RECLAMATION PLANT ASSESSMENTS | 10-20 |
| 10.8.1 | HWRP..... | 10-20 |
| 10.8.2 | DCTWRP | 10-22 |
| 10.8.3 | LAGWRP | 10-24 |
| 10.8.4 | TIWRP | 10-26 |
| 10.9 | SUMMARY OF RECOMMENDED PROJECTS | 10-29 |
| 10.9.1 | Pumping Plants and LFD Improvements Prioritization..... | 10-29 |

| | | |
|--------|-----------------------------------------------------------|-------|
| 10.9.2 | Water Reclamation Plant Improvements Prioritization | 10-32 |
| 10.9.3 | Other Considerations | 10-33 |

CHAPTER 11 – WASTEWATER FACILITIES ADAPTIVE CAPITAL IMPROVEMENT PLAN

| | | |
|------|------------------------------------------------|-------|
| 11.1 | BASIS FOR ESTIMATE OF COST | 11-1 |
| 11.2 | CIP TERMS AND DEFINITIONS..... | 11-4 |
| 11.3 | IN-PROGRESS PROJECTS..... | 11-6 |
| 11.4 | CURRENT INTEGRATION OPPORTUNITIES | 11-7 |
| 11.5 | FUTURE INTEGRATION OPPORTUNITES | 11-7 |
| | 11.5.1 Trigger Based CIP Implementation..... | 11-8 |
| | 11.5.2 Concept Option Summary | 11-17 |
| 11.6 | WASTEWATER FACILITIES PLAN CIP SUMMARY | 11-18 |
| | 11.6.1 Capital Improvement Plan by Phase | 11-19 |
| 11.7 | WASTEWATER FACILITIES ADAPTIVE CIP | 11-22 |
| 11.8 | ESCALATED CIP | 11-25 |

LIST OF APPENDICES

| | |
|------------|--------------------------------------------------------------|
| APPENDIX A | References |
| APPENDIX B | Collection System Supplemental Information |
| APPENDIX C | Hyperion Water Reclamation Plant Concept Options |
| APPENDIX D | Donald C. Tillman Water Reclamation Plant Concept Options |
| APPENDIX E | Los Angeles-Glendale Water Reclamation Plant Concept Options |
| APPENDIX F | Biosolids Data |
| APPENDIX G | Technical Support Materials |
| APPENDIX H | Wastewater Improvement Program Details |

LIST OF TABLES

| | | |
|-------------|----------------------------------------------------------|-------|
| Table ES.1 | Projected Wastewater Flows | ES-8 |
| Table ES.2 | Future Regulatory Drivers for WRP Planning..... | ES-12 |
| Table ES.3 | Near-Term Wastewater Collection System Improvements..... | ES-14 |
| Table ES.4 | Water Reclamation Plant Summary..... | ES-15 |
| Table ES.5 | Water Reuse Concept Options | ES-25 |
| Table ES.6 | HWRP Concept Options..... | ES-27 |
| Table ES.7 | HWRP Flow Assumptions..... | ES-29 |
| Table ES.8 | DCTWRP Concept Options | ES-35 |
| Table ES.9 | DCTWRP Flow Assumptions | ES-37 |
| Table ES.10 | LAGWRP Concept Options | ES-42 |
| Table ES.11 | LAGWRP Flow Assumptions | ES-44 |
| Table ES.12 | TIWRP Flow Assumptions | ES-48 |
| Table ES.13 | Summary of In Progress Project Estimated Costs | ES-54 |
| Table ES.14 | Summary of Concept Option Portfolios..... | ES-56 |
| Table ES.15 | WWFP Adaptive CIP Summary 2017 (\$M) | ES-57 |
| Table 1.1 | Wastewater Facilities Plan Organization..... | 1-3 |
| Table 2.1 | Projected Wastewater Flows | 2-5 |

| | | |
|------------|------------------------------------------------------------------------------------------------------|------|
| Table 2.2 | Potential Regulatory Drivers | 2-11 |
| Table 2.3 | HWRP Potential Regulatory Drivers | 2-12 |
| Table 2.4 | DCTWRP and LAGWRP Potential Regulatory Drivers | 2-13 |
| Table 2.5 | TIWRP Potential Regulatory Drivers..... | 2-14 |
| Table 2.6 | Pipeline and Pump Station Assumptions | 2-15 |
| Table 2.7 | Advanced Water Treatment Assumptions..... | 2-16 |
| Table 2.8 | Groundwater Recharge and Extraction Assumptions..... | 2-16 |
| | | |
| Table 3.1 | Contract Agencies | 3-3 |
| Table 3.2 | Summary of HSA Major Sewers | 3-5 |
| Table 3.3 | Summary of HSA Major Diversion Structures | 3-7 |
| Table 3.4 | HSA Pumping Plants | 3-8 |
| Table 3.5 | TISA Pumping Plants | 3-9 |
| Table 3.6 | City-Owned Low Flow Diversions | 3-11 |
| Table 3.7 | Non-City-Owned Low Flow Diversions | 3-12 |
| Table 3.8 | CIP Terms and Definition | 3-17 |
| Table 3.9 | Collection System Estimated CIP | 3-18 |
| | | |
| Table 4.1 | HWRP Influent Flows | 4-6 |
| Table 4.2 | HWRP NPDES Effluent Limitations | 4-7 |
| Table 4.3 | HWRP Preliminary Treatment Facilities Design Criteria ⁽¹⁾ | 4-9 |
| Table 4.4 | HWRP Preliminary Characteristics | 4-10 |
| Table 4.5 | HWRP Primary Treatment Facilities Design Criteria | 4-12 |
| Table 4.6 | HWRP Primary Clarification Characteristics | 4-13 |
| Table 4.7 | HWRP Intermediate Pumping Station Facilities..... | 4-13 |
| Table 4.8 | HWRP IPS Characteristics | 4-14 |
| Table 4.9 | HWRP High Purity Oxygen Generation Facilities Design Criteria | 4-15 |
| Table 4.10 | HWRP Secondary Treatment Design Criteria..... | 4-19 |
| Table 4.11 | HWRP Secondary Treatment Characteristics..... | 4-22 |
| Table 4.12 | HWRP Effluent Discharge Facilities Design Criteria | 4-23 |
| Table 4.13 | HWRP Effluent Pump Station Design Criteria..... | 4-24 |
| Table 4.14 | HWRP Ocean Outfall Capacities (mgd)..... | 4-25 |
| Table 4.15 | HWRP Effluent Discharge Characteristics | 4-25 |
| Table 4.16 | HWRP Primary Sludge Thickening Facilities Design Criteria..... | 4-26 |
| Table 4.17 | HWRP Waste Activated Sludge Thickening Facility Design Criteria | 4-27 |
| Table 4.18 | HWRP Anaerobic Digestion Facilities Design Criteria..... | 4-28 |
| Table 4.19 | HWRP Digested Sludge Processing Facilities Design Criteria..... | 4-29 |
| Table 4.20 | HWRP HBEF Design Criteria | 4-31 |
| Table 4.21 | HWRP Service Water Facility Design Criteria..... | 4-35 |
| Table 4.22 | HWRP Recent and Ongoing Plant Upgrades | 4-37 |
| Table 4.23 | HWRP In-Progress Projects | 4-40 |
| Table 4.24 | HWRP Upgrades for Advanced Treated Water Delivery to LAX and Scattergood Generating Station | 4-42 |
| Table 4.25 | Potential Upgrades for HWRP Delivery Expansion to 70 mgd for WBMWD and LA Harbor Area | 4-50 |
| Table 4.26 | HWRP Projected Wastewater Flows | 4-51 |
| Table 4.27 | HWRP Flow Assumptions | 4-52 |
| Table 4.28 | HWRP Concept Options..... | 4-54 |
| Table 4.29 | Potential Upgrades MBR at HWRP to Regional System..... | 4-58 |
| Table 4.30 | CIP Terms and Definition | 4-62 |
| Table 4.31 | Summary of In-Progress Project Estimated Costs | 4-63 |

| | | |
|------------|----------------------------------------------------------------|------|
| Table 4.32 | HWRP Estimated and Projected CIP | 4-64 |
| Table 4.33 | HWRP Adaptive CIP Summary 2017 (\$M)..... | 4-67 |
| | | |
| Table 5.1 | DCTWRP Average Influent Flow and Quality..... | 5-6 |
| Table 5.2 | DCTWRP NPDES Effluent Limitations..... | 5-7 |
| Table 5.3 | DCTWRP Preliminary Treatment Design Criteria..... | 5-8 |
| Table 5.4 | DCTWRP Primary Clarifiers Design Criteria | 5-10 |
| Table 5.5 | DCTWRP Primary Flow Equalization Facilities | 5-11 |
| Table 5.6 | DCTWRP Primary Treatment Performance | 5-12 |
| Table 5.7 | DCTWRP NdN Zone Description..... | 5-13 |
| Table 5.8 | DCTWRP NdN Aeration Tanks per Phase Design Criteria | 5-14 |
| Table 5.9 | DCTWRP Secondary Treatment Performance | 5-15 |
| Table 5.10 | DCTWRP Process Air System Design Criteria | 5-16 |
| Table 5.11 | DCTWRP Secondary Clarifiers Design Criteria | 5-17 |
| Table 5.12 | DCTWRP Secondary Clarifiers Performance..... | 5-18 |
| Table 5.13 | DCTWRP RAS System Design Criteria | 5-18 |
| Table 5.14 | DCTWRP Tertiary Treatment Facilities Design Criteria..... | 5-19 |
| Table 5.15 | DCTWRP Disinfection Facilities Design Criteria | 5-21 |
| Table 5.16 | DCTWRP Disinfection Performance | 5-22 |
| Table 5.17 | DCTWRP Dechlorination Facilities Design Criteria | 5-23 |
| Table 5.18 | DCTWRP Average Effluent Water Reuse..... | 5-24 |
| Table 5.19 | DCTWRP Recent and Ongoing Plant Upgrades..... | 5-25 |
| Table 5.20 | DCTWRP In-Progress Project | 5-28 |
| Table 5.21 | AWPF Construction and Future Expansion..... | 5-29 |
| Table 5.22 | DCTWRP Projected Wastewater Flows..... | 5-32 |
| Table 5.23 | DCTWRP Flow Assumptions | 5-33 |
| Table 5.24 | DCTWRP Concept Options | 5-35 |
| Table 5.25 | System Upgrades for Concept Option #15 (DCTWRP to LAAFP)..... | 5-39 |
| Table 5.26 | Potential Upgrades Concept Option #15 (DCTWRP to LAAFP)..... | 5-41 |
| Table 5.27 | Design Criteria for Concept Option #15 (DCTWRP to LAAFP) | 5-42 |
| Table 5.28 | System Upgrades for Concept Option #22 (EWVIS)..... | 5-44 |
| Table 5.29 | Additional Project for Consideration..... | 5-46 |
| Table 5.30 | CIP Terms and Definition..... | 5-48 |
| Table 5.31 | Summary of DCTWRP In-Progress Project Estimated Costs..... | 5-50 |
| Table 5.32 | DCTWRP Estimated and Projected CIP | 5-51 |
| Table 5.33 | DCTWRP Adaptive CIP Summary 2017 (\$M)..... | 5-53 |
| | | |
| Table 6.1 | LAGWRP Influent Flow and Characteristics..... | 6-6 |
| Table 6.2 | LAGWRP NPDES Effluent Limitations..... | 6-7 |
| Table 6.3 | LAGWRP Preliminary Treatment Design Criteria..... | 6-9 |
| Table 6.4 | LAGWRP Primary Treatment Design Criteria | 6-10 |
| Table 6.5 | LAGWRP Primary Treatment Performance | 6-11 |
| Table 6.6 | LAGWRP NdN Treatment Design Criteria | 6-13 |
| Table 6.7 | LAGWRP NdN Zone Description | 6-13 |
| Table 6.8 | LAGWRP NdN Treatment Performance | 6-15 |
| Table 6.9 | LAGWRP Process Air System Design Criteria..... | 6-15 |
| Table 6.10 | LAGWRP Secondary Clarifiers Design Criteria..... | 6-16 |
| Table 6.11 | LAGWRP Secondary Clarifier Performance..... | 6-17 |
| Table 6.12 | LAGWRP RAS System Design Criteria | 6-18 |
| Table 6.13 | LAGWRP Pumping and Coagulation Design Criteria..... | 6-19 |
| Table 6.14 | LAGWRP Filtration Design Criteria..... | 6-20 |

| | | |
|------------|---------------------------------------------------------------------------------------------|------|
| Table 6.15 | LAGWRP Disinfection Design Criteria | 6-22 |
| Table 6.16 | LAGWRP Disinfection Performance | 6-23 |
| Table 6.17 | LAGWRP Dechlorination Design Criteria..... | 6-23 |
| Table 6.18 | LAGWRP Recent and Ongoing Plant Upgrades..... | 6-25 |
| Table 6.19 | LAGWRP In-Progress Project | 6-28 |
| Table 6.20 | LAGWRP Projected Wastewater Flows | 6-29 |
| Table 6.21 | LAGWRP Flow Assumptions..... | 6-30 |
| Table 6.22 | LAGWRP Concept Options | 6-32 |
| Table 6.23 | System Upgrades for Concept Option #17 (LAGWRP to Headworks Reservoir)..... | 6-35 |
| Table 6.24 | Design Criteria for Concept Option #17 (LAGWRP to Headworks Reservoir) ⁽¹⁾ | 6-39 |
| Table 6.25 | Additional Projects for Consideration..... | 6-40 |
| Table 6.26 | CIP Terms and Definition | 6-42 |
| Table 6.27 | Summary of In Progress Project Estimated Costs | 6-43 |
| Table 6.28 | LAGWRP Estimated and Projected CIP | 6-44 |
| Table 6.29 | LAGWRP Adaptive CIP Summary 2017 (\$M)..... | 6-46 |
| | | |
| Table 7.1 | TIWRP Influent Flow and Characteristics | 7-6 |
| Table 7.2 | TIWRP NPDES Effluent Limitations..... | 7-7 |
| Table 7.3 | TIWRP NPDES Recycled Water Constituent Limits | 7-7 |
| Table 7.4 | TIWRP Preliminary Treatment Design Criteria | 7-10 |
| Table 7.5 | TIWRP Primary Treatment Design Criteria..... | 7-12 |
| Table 7.6 | TIWRP Primary Treatment Performance | 7-13 |
| Table 7.7 | TIWRP Secondary Treatment Design Criteria | 7-15 |
| Table 7.8 | TIWRP Aeration Basin Grids | 7-16 |
| Table 7.9 | TIWRP Secondary Treatment Performance | 7-18 |
| Table 7.10 | TIWRP Tertiary Treatment Design Criteria | 7-19 |
| Table 7.11 | TIWRP Tertiary Quality and Limits..... | 7-21 |
| Table 7.12 | TIWRP Advanced Treatment Facilities Design Criteria..... | 7-24 |
| Table 7.13 | TIWRP Design Criteria – Effluent Discharge Facility | 7-28 |
| Table 7.14 | TIWRP Solids Handling Facility Design Criteria..... | 7-30 |
| Table 7.15 | TIWRP Solids Handling Performance..... | 7-32 |
| Table 7.16 | TIWRP Sidestreams Flows..... | 7-33 |
| Table 7.17 | TIWRP In-Plant Sewer Drains Design Criteria..... | 7-34 |
| Table 7.18 | TIWRP Recent and Ongoing Plant Upgrades..... | 7-35 |
| Table 7.19 | TIWRP Projected Wastewater Flows | 7-41 |
| Table 7.20 | TIWRP Flow Assumptions..... | 7-42 |
| Table 7.21 | Alternatives to increase flow to TIWRP..... | 7-46 |
| Table 7.22 | Additional Projects for Consideration..... | 7-47 |
| Table 7.23 | CIP Terms and Definition | 7-49 |
| Table 7.24 | Summary of TIWRP In-Progress Project Estimated Costs..... | 7-50 |
| Table 7.25 | TIWRP Estimated and Projected CIP | 7-51 |
| Table 7.26 | TIWRP Adaptive CIP Summary 2017 (\$M)..... | 7-53 |
| | | |
| Table 8.1 | Rancho Park Drainage Area Land Use Summary..... | 8-7 |
| | | |
| Table 9.1 | Biosolids Distribution | 9-2 |
| Table 9.2 | Projected Wastewater Flows | 9-7 |
| | | |
| Table 10.1 | Climate Change Conditions Used in Risk Assessments and | |

| | | |
|-------------|---------------------------------------------------------------------|-------|
| | Resilience Planning | 10-3 |
| Table 10.2 | Wastewater Pumping Plants..... | 10-4 |
| Table 10.3 | City-Owned Low Flow Diversions | 10-10 |
| Table 10.4 | Climate Change Risk Analysis Prioritization | 10-29 |
| Table 10.5 | Pumping Plants Identified for Climate Hazard Improvements | 10-30 |
| Table 11.1 | Projected Capital and Replacement and Rehabilitation Estimates..... | 11-4 |
| Table 11.2 | CIP Terms and Definition..... | 11-5 |
| Table 11.3 | Summary of In Progress Project Estimated Costs | 11-6 |
| Table 11.4 | HWRP Concept Options | 11-8 |
| Table 11.5 | DCTWRP Concept Options | 11-12 |
| Table 11.6 | LAGWRP Concept Options | 11-14 |
| Table 11.7 | Summary of Concept Option Portfolios..... | 11-17 |
| Table 11.8 | Summary of Priority A Triggers..... | 11-18 |
| Table 11.9 | Number of Projects by Facility | 11-19 |
| Table 11.10 | WWFP Adaptive CIP Summary | 11-22 |

LIST OF FIGURES

| | | |
|--------------|---------------------------------------------------------------------------------------------|-------|
| Figure ES.1 | HSA and TISA Service Boundaries | ES-5 |
| Figure ES.2 | Los Angeles Sewersheds | ES-6 |
| Figure ES.3 | Projected and Historical Average Annual Wastewater Flows | ES-7 |
| Figure ES.4 | Low Flow Diversions..... | ES-9 |
| Figure ES.5 | Wastewater Flow Projections by WRP..... | ES-10 |
| Figure ES.6 | Process Flow Diagram for HWRP..... | ES-17 |
| Figure ES.7 | Process Flow Diagram for DCTWRP | ES-19 |
| Figure ES.8 | Process Flow Diagram for LAGWRP | ES-22 |
| Figure ES.9 | Process Flow Diagram for TIWRP | ES-24 |
| Figure ES.10 | Trigger-Based Implementation Strategy for HWRP..... | ES-28 |
| Figure ES.11 | Estimated Flow Availability for Water Reuse from HWRP (2040 Projection) | ES-30 |
| Figure ES.12 | Process Flow Schematic for Concept Option #13 (MBR at HWRP to Regional System) | ES-31 |
| Figure ES.13 | Potential Upgrades for Concept Option #13 (MBR at HWRP to Regional System) | ES-33 |
| Figure ES.14 | Trigger-Based Implementation Strategy for DCTWRP | ES-36 |
| Figure ES.15 | Estimated Flow Availability for Water Reuse from DCTWRP (2040 Projection) | ES-38 |
| Figure ES.16 | Process Flow Schematic Concept Option #22 (East-West Valley Interceptor Sewer) | ES-39 |
| Figure ES.17 | Process Flow Schematic for Concept Option #15 (DCTWRP to LAAFP)..... | ES-39 |
| Figure ES.18 | Potential Expansion Areas for Concept Option #15 (DCTWRP to LAAFP)..... | ES-40 |
| Figure ES.19 | Trigger-Based Implementation Strategy for LAGWRP | ES-43 |
| Figure ES.20 | Estimated Flow Availability for Water Reuse from LAGWRP (2040 Projection) | ES-45 |
| Figure ES.21 | Process Flow Schematic Concept Option #17 (LAGWRP to Headworks Reservoir) | ES-46 |
| Figure ES.22 | Potential Process Location for Concept Option # 17 (LAGWRP to Headworks Reservoir) | ES-47 |

| | | |
|--------------|--------------------------------------------------------------------------------------|-------|
| Figure ES.23 | Estimated Flow Availability for Water Reuse from TIWRP (2040 Projection) | ES-48 |
| Figure ES.24 | WWFP Adaptive CIP Summary by Phase | ES-59 |
| Figure ES.25 | WWFP Adaptive CIP by Category | ES-59 |
| Figure ES.26 | CIP Comparison of Net Present Values..... | ES-61 |
| Figure ES.27 | Timeline for Wastewater Facilities Plan | ES-62 |
| Figure 2.1 | City of Los Angeles Wastewater System Service Area | 2-2 |
| Figure 2.2 | Projected and Historical Average Annual Wastewater Flows..... | 2-4 |
| Figure 2.3 | Projected Wastewater Flows by Plant | 2-6 |
| Figure 2.4 | Low Flow Diversions | 2-7 |
| Figure 3.1 | City Sewage Service Area..... | 3-2 |
| Figure 3.2 | HSA Collection System | 3-6 |
| Figure 3.3 | TISA Collection System..... | 3-10 |
| Figure 3.4 | Summary of Collection System Projected CIP Costs..... | 3-18 |
| Figure 3.5 | Collection System Projected CIP Costs by Category in 2017 Dollars | 3-19 |
| Figure 3.6 | Present Worth Comparison: Escalated versus Non Escalated CIP..... | 3-20 |
| Figure 4.1 | HWRP Aerial Overview | 4-2 |
| Figure 4.2 | HWRP Location and Sewershed | 4-3 |
| Figure 4.3 | HWRP Process Flow Diagram..... | 4-5 |
| Figure 4.4 | High-Purity Oxygen Reactors Schematic..... | 4-18 |
| Figure 4.5 | HBEF Schematic..... | 4-33 |
| Figure 4.6 | Potential Upgrades of HAWPF for Delivery to LAX and Vicinity..... | 4-44 |
| Figure 4.7 | HAWPF and Delivery to LAWA and Vicinity (1.5 mgd)..... | 4-45 |
| Figure 4.8 | HAWPF and Delivery to LAWA and Vicinity (5 mgd) | 4-46 |
| Figure 4.9 | HAWPF and Delivery to LAWA and Vicinity Reservoir Site | 4-48 |
| Figure 4.10 | Delivery Expansion to 70 mgd for WBMWD and Harbor..... | 4-49 |
| Figure 4.11 | Estimated Flow Availability for Water Reuse from HWRP (2040 Projection) | 4-52 |
| Figure 4.12 | Trigger-Based Implementation Strategy for HWRP | 4-56 |
| Figure 4.13 | Process Flow Schematic for Concept Option #13 (MBR at HWRP to Regional System) | 4-57 |
| Figure 4.14 | Potential Upgrades for Concept Option #13 (MBR at HWRP to Regional System) | 4-60 |
| Figure 4.15 | Summary of HWRP Estimated and Projected CIP Costs..... | 4-65 |
| Figure 4.16 | HWRP Estimated and Projected CIP Costs by Category..... | 4-66 |
| Figure 4.17 | HWRP Adaptive CIP Summary by Phase..... | 4-68 |
| Figure 4.18 | HWRP Adaptive CIP Summary by Category | 4-68 |
| Figure 4.19 | Present Worth Comparison: Escalated versus Non Escalated CIP..... | 4-69 |
| Figure 5.1 | DCTWRP Aerial Overview..... | 5-2 |
| Figure 5.2 | DCTWRP Location and Sewershed..... | 5-3 |
| Figure 5.3 | DCTWRP Process Flow Diagram..... | 5-5 |
| Figure 5.4 | DCTWRP Future Expansion Plan..... | 5-31 |
| Figure 5.5 | Estimated Flow Availability for Water Reuse from DCTWRP (2040 Projection)..... | 5-34 |
| Figure 5.6 | Trigger-Based Implementation Strategy for DCTWRP..... | 5-38 |
| Figure 5.7 | Process Flow Schematic Concept Option #15 (DCTWRP to LAAFP) | 5-39 |
| Figure 5.8 | System Upgrades for Concept Option #15 (DCTWRP to LAAFP) | 5-40 |

| | | |
|-------------|--------------------------------------------------------------------------------------------|------|
| Figure 5.9 | Potential Upgrades for Concept Option #15 (DCTWRP to LAAFP)..... | 5-43 |
| Figure 5.10 | Process Flow Schematic for Concept Option #22 (EWVIS) | 5-44 |
| Figure 5.11 | System Upgrades for Concept Option #22 (EWVIS)..... | 5-45 |
| Figure 5.12 | Summary of DCTWRP Estimated and Projected CIP Costs | 5-52 |
| Figure 5.13 | DCTWRP Estimated and Projected CIP Costs by Category in 2017 Dollars | 5-53 |
| Figure 5.14 | DCTWRP Adaptive CIP Summary by Phase | 5-54 |
| Figure 5.15 | DCTWRP Adaptive CIP Summary by Category | 5-55 |
| Figure 5.16 | Present Worth Comparison: Escalated versus Non Escalated CIP | 5-56 |
| | | |
| Figure 6.1 | LAGWRP Aerial Overview | 6-2 |
| Figure 6.2 | LAGWRP Location and Sewershed | 6-3 |
| Figure 6.3 | LAGWRP Process Flow Diagram | 6-5 |
| Figure 6.4 | Estimated Flow Availability for Water Reuse from LAGWRP (2040 Projection) | 6-30 |
| Figure 6.5 | LAGWRP Primary Effluent Equalization Storage | 6-31 |
| Figure 6.6 | Trigger-Based Implementation Strategy for LAGWRP | 6-34 |
| Figure 6.7 | Process Flow Schematic for Concept Option #17 (LAGWRP to Headworks Reservoir) | 6-35 |
| Figure 6.8 | System Upgrades for Concept Option #17 (LAGWRP to Headworks Reservoir)..... | 6-36 |
| Figure 6.9 | Potential Process Location for Concept Option #17 (LAGWRP to Headworks Reservoir) | 6-38 |
| Figure 6.10 | Summary of LAGWRP Estimated and Projected CIP Costs | 6-45 |
| Figure 6.11 | LAGWRP Estimated and Projected CIP Costs by Category | 6-46 |
| Figure 6.12 | LAGWRP Adaptive CIP Summary by Phase | 6-47 |
| Figure 6.13 | LAGWRP Adaptive CIP Summary by Category | 6-48 |
| Figure 6.14 | Present Worth Comparison: Escalated versus Non Escalated CIP | 6-49 |
| | | |
| Figure 7.1 | TIWRP Aerial Overview | 7-2 |
| Figure 7.2 | TIWRP Location and Sewershed | 7-3 |
| Figure 7.3 | TIWRP Process Flow Diagram | 7-5 |
| Figure 7.4 | TIWRP AWPf Process Flow Diagram | 7-23 |
| Figure 7.5 | Existing and Future RW Distribution System from TIWRP AWPf to Harbor Area Users..... | 7-38 |
| Figure 7.6 | Site Layout for Phase 1 and Phase 2 AWPf at TIWRP | 7-39 |
| Figure 7.7 | Estimated Flow Availability for Water Reuse from TIWRP (2040 Projection) | 7-42 |
| Figure 7.8 | Produce Nitrified Denitrified MBR Secondary Effluent at HWRP | 7-44 |
| Figure 7.9 | Transfer Raw Sewage from the LACSD System to TIWRP | 7-45 |
| Figure 7.10 | Summary of TIWRP Estimated and Projected CIP Costs | 7-52 |
| Figure 7.11 | TIWRP Estimated and Projected CIP Costs by Category | 7-52 |
| Figure 7.12 | TIWRP Adaptive CIP Summary by Phase | 7-54 |
| Figure 7.13 | Present Worth Comparison: Escalated versus Non Escalated CIP | 7-55 |
| | | |
| Figure 8.1 | Rancho Park Drainage Area Map | 8-6 |
| Figure 8.2 | Average Diurnal Curve at WRS Gauge #51906144 | 8-8 |
| | | |
| Figure 9.1 | Trend in Biosolids at TIWRP from 2006 through 2016 | 9-3 |
| Figure 9.2 | Trend in Biosolids at HWRP from 2006 through 2016..... | 9-4 |

| | | |
|--------------|-------------------------------------------------------------------------------------------------------------------------------------|-------|
| Figure 10.1 | WLA Primary Sewer Basin | 10-13 |
| Figure 10.2 | Current and Modified 10-Yr/24-Hr Design Storm Hyetograph | 10-15 |
| Figure 10.3 | Calculated Collection System Surcharging for Design Storm with Existing Conditions and Climate Change Conditions in Year 2050 | 10-16 |
| Figure 10.4 | Wastewater and Stormwater Pumping Plants and Low Flow Diversions with Current and/or Future Climate Hazard Risks | 10-31 |
| Figure 11.1 | Projected Annual Estimate of Cost for WRP | 11-3 |
| Figure 11.2 | Trigger-Based Implementation Strategy for HWRP | 11-11 |
| Figure 11.3 | Trigger-Based Implementation Strategy for DCTWRP | 11-15 |
| Figure 11.4 | Trigger-Based Implementation Strategy for LAGWRP | 11-16 |
| Figure 11.5 | Near-Term CIP Summary | 11-20 |
| Figure 11.6 | Mid-Term CIP Summary | 11-21 |
| Figure 11.7 | Long Term CIP Summary | 11-22 |
| Figure 11.8 | Wastewater Facilities Plan Adaptive CIP Summary by Phase | 11-24 |
| Figure 11.9 | WWFP Adaptive CIP by Category | 11-25 |
| Figure 11.10 | CIP Comparison of Net Present Values | 11-26 |
| Figure 11.11 | Timeline for Wastewater Facilities Plan | 11-27 |

LIST OF ABBREVIATIONS

| Abbreviation | Description |
|---------------------|-----------------------------------------------|
| °C | degrees Celsius |
| °F | degrees Fahrenheit |
| µm | micrometer |
| AAWRE | American Academy of Water Resources Engineers |
| ADA | Americans with Disabilities Act |
| ADD | average day demand |
| ADF | average day flow |
| ADWF | average dry-weather flow |
| AFY | acre-feet per year |
| AMSL | above mean sea level |
| AOP | advanced oxidation process |
| AQMD | Air Quality Management District |
| AS | activated sludge |
| ASCE | American Society of Civil Engineers |
| ATFs | air treatment facilities |
| AVORS | Additional Valley Outfall Relief Sewer |
| AWPF | Advanced Water Purification Facility |
| AWT | advanced water treatment |
| BAC | biologically activated carbon |
| BAF | biologically active filter |
| BFE | base flood elevation |
| BM | Burns McDonnell |
| BMPs | Best Management Practices |
| BOD | biochemical oxygen demand |
| BOD5 | 5-day biochemical oxygen demand |
| BOE | Los Angeles Bureau of Engineering |
| BRK | brick |
| BTF | biotrickling filters |
| BWRP | Burbank Water Reclamation Plant |
| CaCl ₂ | calcium chloride |
| Caltrans | California Department of Transportation |
| CCR | California Code of Regulations |
| CCTV | closed circuit television |
| CDPH | California Department of Public Health |
| CEC | constituents of emerging concern |
| cfm/lb | cubic feet per minute per pound |
| cfs | cubic feet per second |
| CFSC | Central Flare System Controller |
| CIP | Capital Improvement Plan |
| CIRS | Coastal Interceptor Relief Sewer |

| Abbreviation | Description |
|---------------------|--------------------------------------------------|
| CIS | Coastal Interceptor Sewer |
| City | City of Los Angeles |
| Cl ₂ | chlorine gas |
| CO ₂ | carbon dioxide |
| CON | unreinforced concrete |
| COS | Central Outfall Sewer |
| CREAT | Climate Resilience Evaluation and Awareness Tool |
| CRWRF | Carson Regional Water Reclamation Facility |
| CSWRCB | California State Water Resources Control Board |
| CT | clay tile |
| CTG | combustion turbine generator |
| CWA | Clean Water Act |
| d/D | depth over diameter |
| DAF | dissolved air flotation |
| DBP | disinfection byproducts |
| DCAC | direct contract aftercooler |
| DCS | distributed control system |
| DCTWRP | Donald C. Tillman Water Reclamation Plant |
| DDW | Division of Drinking Water |
| DFE | Design Flood Elevation |
| DGB | Dominguez Gap Barrier |
| DGUP | Digester Gas Utilization Project |
| DHI | Danish Hydraulic Institute, Inc. |
| DICE | Dewatering Interim Cetrifuge Expansion |
| DO | dissolved oxygen |
| DPR | direct potable reuse |
| dtpd | dry tons per day |
| DWF | dry weather flow |
| DWFD | dry and wet weather flow diversion |
| ECIS | East Central Interceptor Sewer |
| ECLWRF | Edward C. Little Water Reclamation Facility |
| ED#5 | Executive Directive No. 5 |
| EIR | Environmental Impact Report |
| EL | elliptical |
| EMPAC | Enterprise Maintenance Planning and Control |
| EPA | Environmental Protection Agency |
| EPP | Effluent Pumping Plant |
| ERIS | Eagle Rock Interceptor Sewer |
| ERP | Enforcement Response Plan |
| ESB | engineered storage buffer |
| ESS | effluent suspended solids |

| Abbreviation | Description |
|---------------------|-----------------------------------------------|
| EVIS | East Valley Interceptor Sewer |
| EVRS | East Valley Relief Sewer |
| EWMP | Enhanced Watershed Management Program |
| EWVIS | East-West Valley Interceptor Sewer |
| FAST | Field Automation for Sanitation Trucks |
| FAT | full advanced treatment |
| FEMA | Federal Emergency Management Agency |
| FGTS | fuel gas treating system |
| FIRMs | flood insurance rate maps |
| FMD | Financial Management Division |
| FOG | fats, oil, and grease |
| FRP | fiberglass-reinforced plastic |
| FSE | food service establishments |
| ft | feet (foot) |
| FY | fiscal year |
| GAC | granular activated carbon |
| GCM | general circulation model |
| gfd | gallons per square foot per day |
| GIS | Geographic Information System |
| GOX | gas oxygen |
| gpcd | gallons per capita per day |
| gpd/sq ft | gallons per day per square foot |
| gped | gallons per employee per day |
| gpm | gallons per minute |
| gpm/sq ft | gallons per minute per square foot |
| GRRP | Groundwater Replenishment Reuse Project |
| GRRR | Groundwater Recharge Reuse Regulations |
| GWI | groundwater infiltration |
| GWR | groundwater replenishment |
| H ₂ S | hydrogen sulfide |
| Harbor | Los Angeles Outer Harbor |
| HAWPF | Hyperion Advanced Water Purification Facility |
| HBEF | Hyperion Bio-Energy Facility |
| HGS | Harbor Generation Station |
| hp | horsepower |
| HP | high pressure |
| HPE | high pressure effluent |
| HPO | high purity oxygen |
| HPO-AS | high purity oxygen-activated sludge |
| HRT | hydraulic retention time |
| HSA | Hyperion Service Area |

| Abbreviation | Description |
|---------------------|--------------------------------------------------|
| HSEPS | Hyperion Secondary Effluent Pump Station |
| HVAC | heating, ventilating and air conditioning |
| HWRP | Hyperion Water Reclamation Plant |
| I/I | inflow and infiltration |
| I-5 | Interstate 5 |
| IBC | International Building Code |
| IDF | intensity, duration, and frequency |
| IPCC | Intergovernmental Panel on Climate Change |
| IPLS | In-Plant Lift Station |
| IPS | intermediate pump station |
| IRP | Integrated Resources Plan |
| IU | industrial user |
| IWMD | Industrial Waste Management Division |
| JWPCP | Joint Water Pollution Control Plant |
| kW | kilowatt |
| LAAFP | Los Angeles Aqueduct Filtration Plant |
| LABOE | Los Angeles Bureau of Engineering |
| LACSD | Los Angeles County Sanitation District |
| LADWP | Los Angeles Department of Water and Power |
| LAGWRP | Los Angeles-Glendale Water Reclamation Plant |
| LAMC | Los Angeles Municipal Code |
| LASAN | Los Angeles Sanitation |
| LAWA | Los Angeles World Airports |
| LAWINS | Los Angeles Wastewater Integrated Network System |
| LAX | Los Angeles International Airport |
| LAZTF | Los Angeles Zoo Treatment Facility |
| lbs/day | pounds per day |
| lbs/hr | pounds per hour |
| lbs/hr/sq ft | pounds per hour per square foot |
| lbs/LOX/hr | pounds per liquid oxygen per hour |
| lbs/sq ft/d | pounds per square foot per day |
| LCIS | La Cienega Interceptor Sewer |
| LCP | local control panels |
| LCSFVRS | La Cienega-San Fernando Valley Relief Sewer |
| LF | linear feet |
| LFD | low flow diversion |
| LIN | liquid nitrogen |
| LNOS | Lower North Outfall Sewer |
| LOX | liquid oxygen |
| LP | low pressure |
| LPE | low pressure effluent |

| Abbreviation | Description |
|---------------------|-------------------------------------------------|
| LSI | Langlier's Saturation Index |
| M | million |
| MBAS | methylene blue-activated substances |
| MBR | membrane bioreactor |
| MCC | motor control center |
| MCP | master control system |
| MF | microfiltration |
| MG | million gallons |
| mg/L | milligrams per liter |
| mgd | million gallons per day |
| ml/L | milliliter per liter |
| MLE | Modified Ludzack Ettinger |
| MLSS | mixed liquor suspended solids |
| MOV | most open valve |
| MS4 | Municipal Separate Storm Sewer System |
| MSL | mean sea level |
| MU | MIKE URBAN software |
| MVA | megavolt amperes |
| MW | megawatt |
| MWD | Municipal Water District |
| N/A | not applicable |
| N ₂ | nitrogen gas |
| NaHSO ₃ | sodium bisulfite |
| NaOCl | sodium hypochlorite |
| NCOS | North Central Outfall Sewer |
| NdeN | nitrification and denitrification |
| NDMA | nitrosodimethylamine |
| NDN | nitrification/denitrification |
| NEIS | North East Interceptor Sewer |
| ng/L | nanograms per liter |
| NH ₃ -N | ammonia nitrogen |
| NH ₄ OH | ammonia hydroxide |
| NHIS | North Hollywood Interceptor Sewer |
| NO ₂ -N | nitrite |
| NO ₃ -N | nitrate |
| NOAA | National Oceanic and Atmospheric Administration |
| NORS | North Outfall Relief Sewer |
| NOS | North Outfall Sewer |
| NOX | nitrogen oxide |
| NPDES | National Pollutant Discharge Elimination System |
| NPR | non-potable reuse |

| Abbreviation | Description |
|---------------------|--------------------------------------------------|
| NTU | nephelometric turbidity unit |
| O&M | operations and maintenance |
| O ₃ /BAF | ozone with biologically active filters |
| Organic-N | organic nitrogen |
| ORP | oxidation-reduction potential |
| OSTFs | onsite treatment facilities |
| PAC | process air compressors |
| pCi/L | picocuries per liter |
| PDWF | peak dry weather flow |
| PE | primary effluent |
| Permit | Industrial Wastewater Permit |
| Plan | One Water LA 2040 Plan |
| PLC | programmable logic controller |
| POTW | Publicly Owned Treatment Works |
| psi | pounds per square inch |
| psig | pounds per square inch gauge |
| PSPS | Primary Sludge Pump Station |
| PVC | polyvinyl chloride |
| PWWF | peak wet weather flow |
| QA/QC | quality assurance/quality control |
| QSFs | quality surcharge fees |
| R&R | replacement and rehabilitation |
| RAP | Los Angeles Department of Recreation and Parks |
| RAS | return activated sludge |
| RCP | reinforced concrete pipe |
| RDI/I | rainfall dependent inflow and infiltration |
| RO | reverse osmosis |
| RWQCB-LA | Los Angeles Regional Quality Water Control Board |
| SAT | soil aquifer treatment |
| SCAQMD | South Coast Air Quality Management District |
| SCAR | Sewer Capacity Availability Review |
| scfm | standard cubic feet per minute |
| SCR | selective catalytic reduction |
| SE | semi-elliptical |
| SFEM | Sewer Flow Estimation Model |
| SFV | San Fernando Valley |
| SGS | Scattergood Generating Station |
| SIP | sewer infiltration and inflow prevention |
| SLR | sea level rise |
| SMART | Sewer Monitoring and Routing Terminal |
| SO ₂ | sulfur dioxide gas |

| Abbreviation | Description |
|---------------------|---------------------------------------------|
| SOP | Standard Operating Procedure |
| SOR | surface overflow rate |
| sq ft | square feet |
| SSC | sewer service charge |
| SSMP | Sewer System Management Plan |
| SSO | sanitary sewer overflow |
| STF | steam turbine generators |
| SUSMP | Standard Urban Stormwater Mitigation Plan |
| SVI | sludge volume index |
| SWD | side water depth |
| SWRCB | State Water Resources Control Board |
| SWTP | surface water treatment plant |
| TDH | total dynamic head |
| TDS | total dissolved solids |
| THM | trihalomethane |
| TIRE | Terminal Island Renewable Energy |
| TISA | Terminal Island Service Area |
| TIWRP | Terminal Island Water Reclamation Plant |
| TM | Technical Memorandum |
| TMDL | total maximum daily load |
| tpd | tons per day |
| TS | total solids |
| TSS | total suspended solids |
| TUa | acute toxic unit |
| TUc | chronic toxic unit |
| UCLA | University of California Los Angeles |
| UF | ultrafiltration |
| ULSFO | ultra-low sulfur fuel oil |
| UPRS | Uniform Project Reporting System |
| USACE | U.S. Army Corps of Engineers |
| UV | ultraviolet |
| UV/AOP | ultraviolet advanced oxidation process |
| UV/NaOCl | ultraviolet irradiation/sodium hypochlorite |
| UWMP | Urban Water Management Plan |
| VAPP | Venice Auxiliary Pumping Plant |
| VCP | vitrified clay pipe |
| VFD | variable frequency drive |
| VOC | volatile organic compounds |
| VORS | Valley Outfall Relief Sewer |
| VPP | Venice Pump Plant |
| VS | Valley Springs |

| Abbreviation | Description |
|---------------------|---------------------------------------------|
| VSL/FA | Valley Spring Lane/Forman Avenue |
| WAS | waste activated sludge |
| WASTF | Waste Activated Sludge Thickening Facility |
| Water IRP | 2006 Water Integrated Water Resources Plan |
| WBMWD | West Basin Municipal Water District |
| WCIP | Wastewater Capital Improvement Plan |
| WHIS | Wilshire-Hollywood Interceptor Sewer |
| WLA | West Los Angeles |
| WLAIS | West Los Angeles Interceptor Sewer |
| WRD | Water Replenishment District |
| WRF | water reclamation facility |
| WRP | water reclamation plant |
| WRS | Westwood Relief Sewer |
| wtpd | wet tons per day |
| WWFP | Wastewater Facilities Plan |
| WWPOP | Wet Weather Preparedness and Operation Plan |

-This Page Left Blank Intentionally-

WASTEWATER FACILITIES PLAN

This Executive Summary provides a summary of the Wastewater Facilities Plan (WWFP), which is included as Volume 2 of the One Water LA 2040 Plan (Plan). The WWFP describes the City of Los Angeles' (City) existing wastewater collection and water reclamation plants (WRPs), as well as the recommended improvements to meet future flow conditions. Both existing system and future system improvements are combined in a comprehensive capital improvement plan (CIP), which is documented in detail in Chapter 11 of the WWFP and summarized at the end of this Executive Summary.

This Executive Summary of the WWFP first describes the purpose of the WWFP and the basis of planning. Subsequently, the existing WRPs and collection system are discussed, followed by a summary of the future system analysis and the recommended wastewater facilities CIP.

ES.1 WASTEWATER FACILITY PLAN PURPOSE

The City of Los Angeles Sanitation Department (LASAN), is responsible for implementing, operating, maintaining, and monitoring a reliable, and sustainable system that conveys and treats wastewater in a cost efficient and environmentally prudent manner while complying with all regulatory permits. LASAN is also playing an important role in meeting the Mayor's water supply goal of sourcing 50 percent of the City's water supply locally by 2035 by appropriately evaluating their WRPs for future opportunities. To add to its role in protecting public health and the environment, LASAN has significant responsibilities for the city-wide stormwater system and solid waste services. LASAN serves over 4 million residential and industrial customers in the City. Additionally, LASAN also provides conveyance and treatment services for an estimated 600,000 residences outside of the City from its 29 contract agencies.

The purpose of the WWFP is to guide LASAN with its decision making related to the implementation of system improvements to its wastewater collection and treatment facilities. The WWFP provides the underlying documentation to make informed decisions when considering investments to repair, replace, or enhance existing facilities and construct new water conveyance or treatment facilities through year 2040. This WWFP is an update of the Wastewater Facilities Plan that was included in the 2006 Water Integrated Resources Plan (Water IRP) This WWFP incorporates expansions, upgrades, and enhancements made since 2006 and builds upon Los Angeles Department of Water and Power's (LADWP) 2015 Urban Water Management Plan (UWMP). It is anticipated that the WWFP will be updated in approximately ten years to incorporate system modifications as well as changes in flow conditions, regulatory framework, and overall vision for wastewater system operations and water reuse.

The WWFP provides recommendations for each plant on how to best utilize the water reuse opportunities and provide environmental stewardship. Among the water reuse opportunities explored are non-potable reuse (NPR) and potable reuse, groundwater augmentation, raw water augmentation, and treated water augmentation. The WWFP used a trigger-based CIP process for the future integration opportunities, which is similar to the approach that was used for the IRP. This trigger-based CIP is explained in more detail in Chapter 10 (see Volume 1) and is designed to help the City navigate the wide range of future circumstances by considering changes in wastewater flows, as well as regulatory, institutional, and other conditions.

ES.2 BASIS OF PLANNING

The WWFP is developed using discrete planning parameters. The basis of planning parameters consist of the planning horizon, study area, regulatory requirements, and wastewater flows, which are briefly described below, and discussed in depth in Volume 2 of this Plan.

- **Planning Horizon:** The planning horizon of the WWFP is year 2040. The intermediate planning period is divided into three phases: near-term (2018-2020); mid-term (2021-2030); and long-term (2031-2040).
- **Study Area:** The study area of the WWFP closely coincides with the City boundary and encompasses approximately 533 square miles. However, certain elements of the WWFP, such as flow, economics, and recycling opportunities transcend City boundaries when considering contract agencies and cities, as well as other involved neighboring entities. A more detailed discussion can be found in Section ES.2.1.
- **Wastewater Flows:** Wastewater flow projections are an important foundation for facility planning. Due to substantial water conservation in the past decades, wastewater flows have substantially decreased. Based on the anticipated effect of demand hardening and moderate growth, the City's combined wastewater flows are projected to increase from 328 million gallons per day (mgd) in the current year (2016) to 376 mgd by 2040. Details on the flow projections by plant are summarized in Section ES.2.2.
- **Regulatory Requirements:** The WWFP considers both existing and anticipated changes to regulations that pertain to wastewater treatment, effluent discharge, and water reuse. A more detailed description of the applicable regulatory framework is summarized in Section ES.2.3.

The WWFP was developed with the One Water LA Objectives and Guiding Principles, developed as part of Phase 1 which pertain specifically to the City's wastewater system and recycling opportunities. These objectives are listed below:

- Objective 5 - Implement, monitor, and maintain **a reliable wastewater system** that safely conveys, treats, and reuses wastewater while also reducing sewer overflows and odors.
- Objective 6 - Increase climate resilience by planning for climate change mitigation and adaptation strategies in all City actions.

Subsequently, Guiding Principles were developed to provide direction on achieving the objectives. These Guiding Principles are not intended to define specific steps for project implementation but to steer the planning process. The Guiding Principles that were used in the development of this WWFP are listed below:

- Optimize the use of existing City assets and infrastructure and explore opportunities for distributed solutions in order to safely convey, treat, and reuse wastewater.
- Optimize water reuse from the City's wastewater system, with particular emphasis on the Hyperion Water Reclamation Plant (HWRP).
- Raise the priority of water issues in relevant City plans that impact sustainability, climate adaptation/resiliency, and emergency preparedness.

The WWFP has reviewed and incorporated these Guiding Principles in the planning process to collectively help achieve the One Water LA Vision as described in Chapter 1 of this Plan. More specifically, the WWFP proposes options to maximize reuse flows at HWRP and studies climate risk mitigation and adaptation strategies for each of the water reclamation plants as well as the collection system.

ES.2.1 Wastewater System Service Area





The WWFP study area coincides with the City's wastewater system service area, which can be divided into two distinct wastewater drainage areas, as well as seven major sewersheds. The drainage areas, major sewersheds, and the City's four WRPs are shown on Figure ES.1 and Figure ES.2.

Figure ES.1 shows the two primary drainage areas, the Hyperion Service Area (HSA) and the Terminal Island Service Area (TISA). These drainage areas are divided into seven major sewersheds, as shown on Figure ES.2.

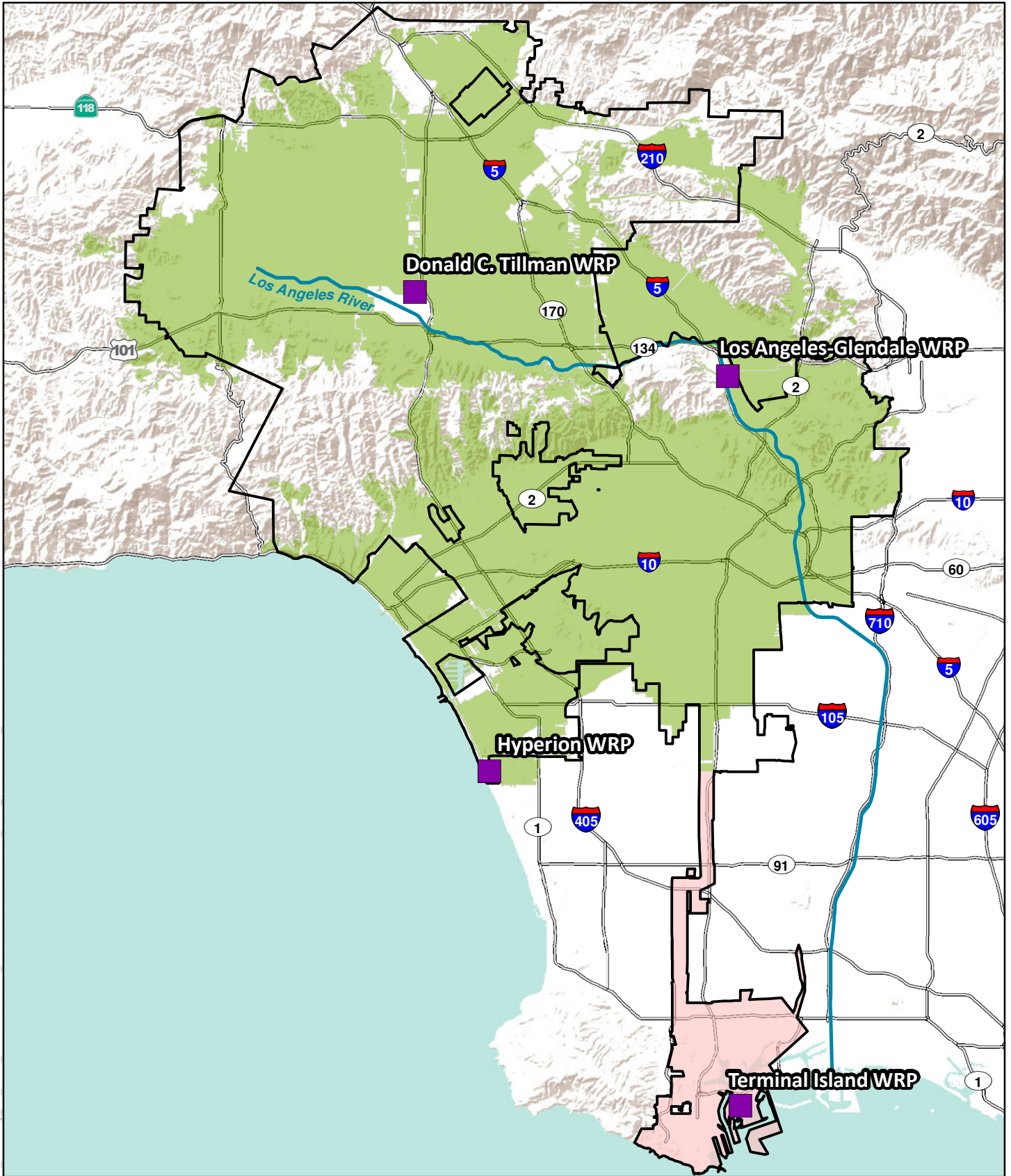
The HSA covers approximately 515 square miles, servicing the majority of the Los Angeles region. The HSA has six sewersheds which are the Donald C. Tillman sewershed, Valley Springs (VS) sewershed, Foreman Line sewershed, Coastal Interception Sewer (CIS) sewershed, Los-Angeles Glendale sewershed, and Hyperion-Metro sewershed. In addition to collecting flows from these sewersheds, the HSA collects, conveys, and treats wastewater from the City's 29 contract agencies that are located outside the City boundary. The entire HSA ultimately drains to the HWRP, while portions of the flows are treated at the inland satellite plants, namely Donald C. Tillman Water Reclamation Plant (DCTWRP) and Los Angeles-Glendale Water Reclamation Plant (LAGWRP).

The TISA is approximately 18 square miles and serves the Los Angeles Harbor area. The TISA consists solely of the Terminal Island sewershed. Most of the TISA drains to the Terminal Island Water Reclamation Plant (TIWRP), while a small portion of the flows are pumped to the Los Angeles County Sanitation Districts (LACSD), Joint Water Pollution Control Plant (JWPCP).



-  Existing Water Reclamation Plant (WRP)
-  City of LA Boundary
-  Hyperion Service Area (HSA)
-  Terminal Island Service Area (TISA)

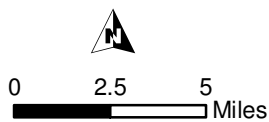
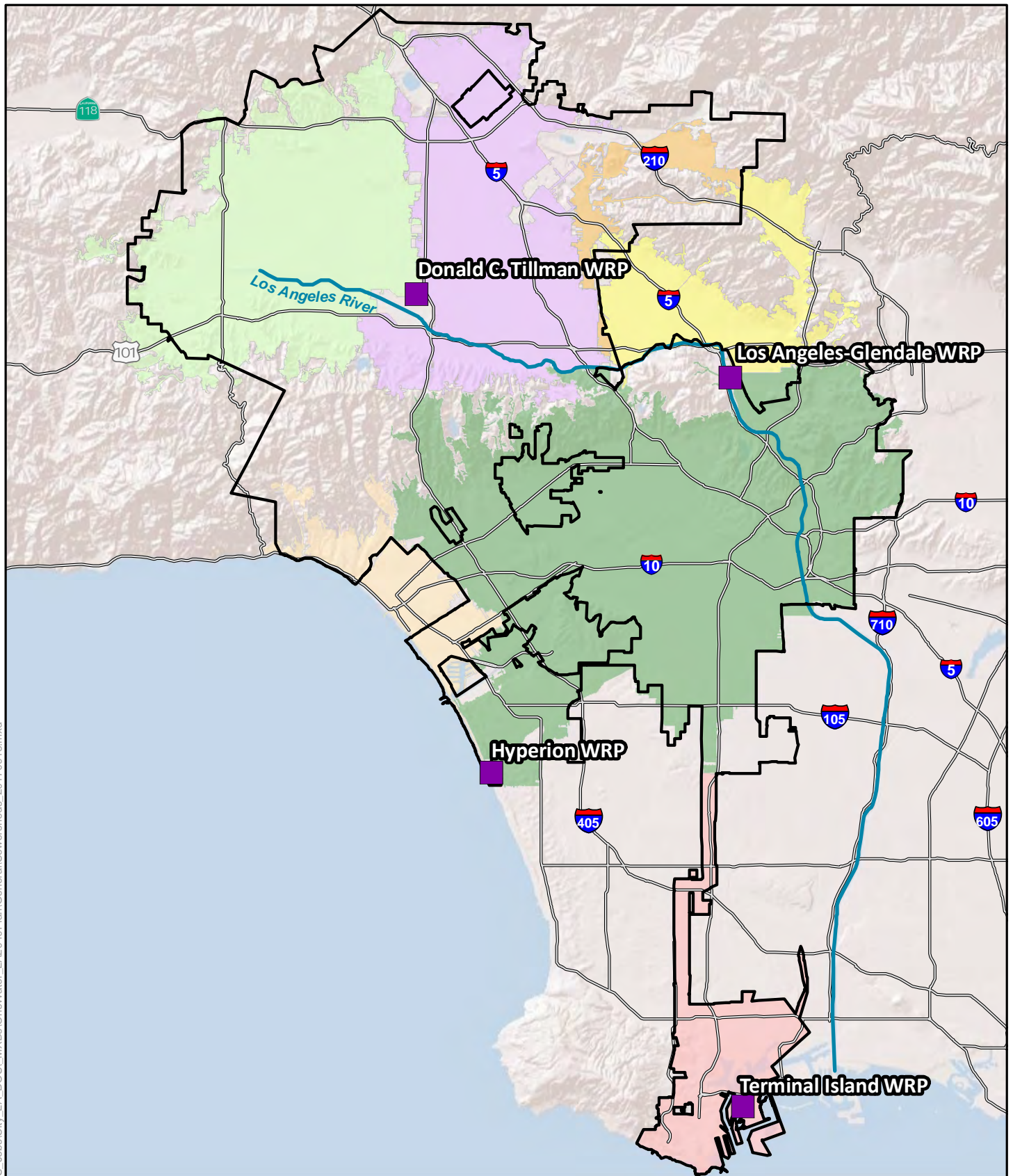

Figure ES.1
HSA and TISA Service Boundaries
One Water LA 2040 Plan



- Existing Water Reclamation Plant (WRP)
- City of LA Boundary
- Terminal Island Sewershed
- LAGWRP Sewershed
- Foreman Line Sewershed
- HWRP Metro Sewershed
- DCTWRP Sewershed
- CIS Sewershed
- Valley Springs Sewershed

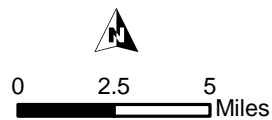

Figure ES.2
Los Angeles Sewersheds
One Water LA 2040 Plan

ES.2.2 Wastewater Flow Projections

Knowledge of future flow projections is vital to CIP planning and management of the wastewater system assets for collection and treatment. Figure ES.3 compares the 2006 Water IRP projections (2005-2020), the actual annual average wastewater flows (2002-2016), and the One Water LA 2040 Plan flow projections. As shown on Figure ES.3, the 2006 Water IRP projected approximately 451 mgd of wastewater influent within the HSA and TISA boundaries in 2015. The actual annual average wastewater influent flows in 2015 for these service boundaries were significantly lower, totaling approximately 337 mgd. This yields a difference of 114 mgd between the projected and the actual flows. This significant difference of influent flows can largely be attributed to the City's successful water conservation efforts. The Plan wastewater influent projections account for conservation efforts and develop flow projections based on estimated conservation, increased population and expected system growth. As a result, the 2020 flow projections differ by 131 mgd between the Water IRP and the Plan projections.

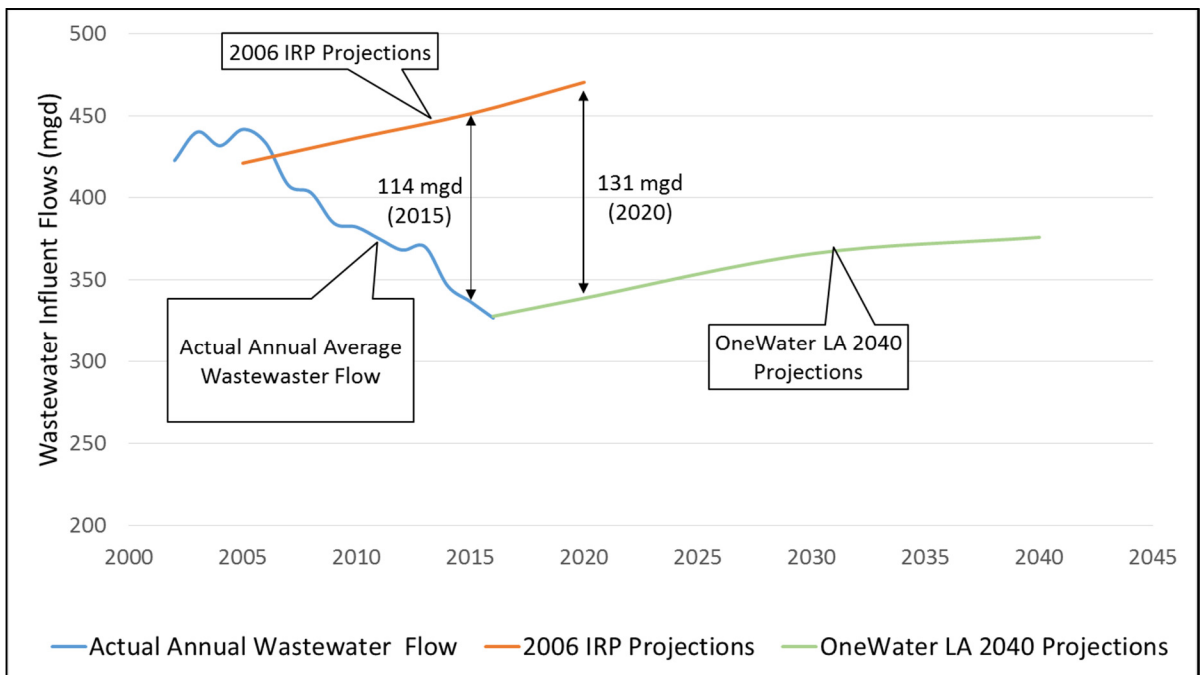

Figure ES.3 Projected and Historical Average Annual Wastewater Flows

Future wastewater flows are expected to increase due to growth in population as well as commercial, and industrial activity. The 2015 UWMP, in conjunction with SCAG census data, projects a growth of an additional 493,200 people within the City by 2040. The population is expected to continue to grow over the next 25 years at a rate of 0.5 percent annually. This represents a reduction to the historical 1 percent annual growth rate that occurred between 1980 and 2010. Population growth is expected to lead to an increase in commercial and industrial activity, likely resulting in an increase in wastewater flows in the City's service area. In general the UWMP states that dry weather wastewater influent flow

projections for the WRPs are expected to increase by 20 percent over the next 25 years.

Along with population growth, wastewater flows will also be influenced by economic activity, weather, and water conservation. However, once conservation efforts are maximized, the demand values are "hardened" and greater efforts are required to create substantive reductions.

It should be noted that this forecast includes the anticipated flows due to the recommended implementation of additional dry weather low flow diversions (LFDs). The City has already implemented numerous dry weather LFDs throughout the City increasing the potential for water reuse. LFDs that route dry weather stormwater flows into the sewer collection system via a pumping facility. These dry weather stormwater flows to increase flows to the WRP increasing the potential for reuse. The City plans to implement a policy to reduce the overall dry weather runoff while also expanding the number of LFDs to maximize dry weather capture. It is anticipated that the City can capture an additional 6,200 acre feet per year (AFY) or 6.5 mgd of flow with LFDs. Depending on which LFDs are built, this could increase influent flows particularly at the inland plants, DCTWRP and LAGWRP. The proposed LFD locations are shown on Figure ES.4.

As shown in Table ES.1, the combined flow of all four WRPs is projected to increase from roughly 328 mgd in 2016 to 376 mgd in 2040. The breakdown of the current and future flow projections for each plant. Figure ES.5 show that the total system net flow will increase by 13 percent by 2040.

| Table ES.1 Projected Wastewater Flows Wastewater Facilities Plan One Water LA 2040 Plan | | | | |
|--------------------------------------------------------------------------------------------------------|----------------------------------------------------------------------------|----------------|----------------|----------------|
| Water Reclamation Plant (WRP) | Projected Annual Average Wastewater Flows by Year^(1,2,3) | | | |
| | 2016 | 2020 | 2030 | 2040 |
| Hyperion | 250 mgd | 256 mgd | 275 mgd | 283 mgd |
| Donald C. Tillman | 47 mgd | 46 mgd | 51 mgd | 53 mgd |
| Los Angeles-Glendale | 17 mgd | 21 mgd | 22 mgd | 22 mgd |
| Terminal Island | 14 mgd | 16 mgd | 18 mgd | 18 mgd |
| Total | 328 mgd | 339 mgd | 366 mgd | 376 mgd |
| Notes: | | | | |
| (1) Flows are rounded to the nearest mgd. | | | | |
| (2) The LFDs are assumed to be implemented starting in Year 2030. | | | | |
| (3) mgd = million gallons per day | | | | |

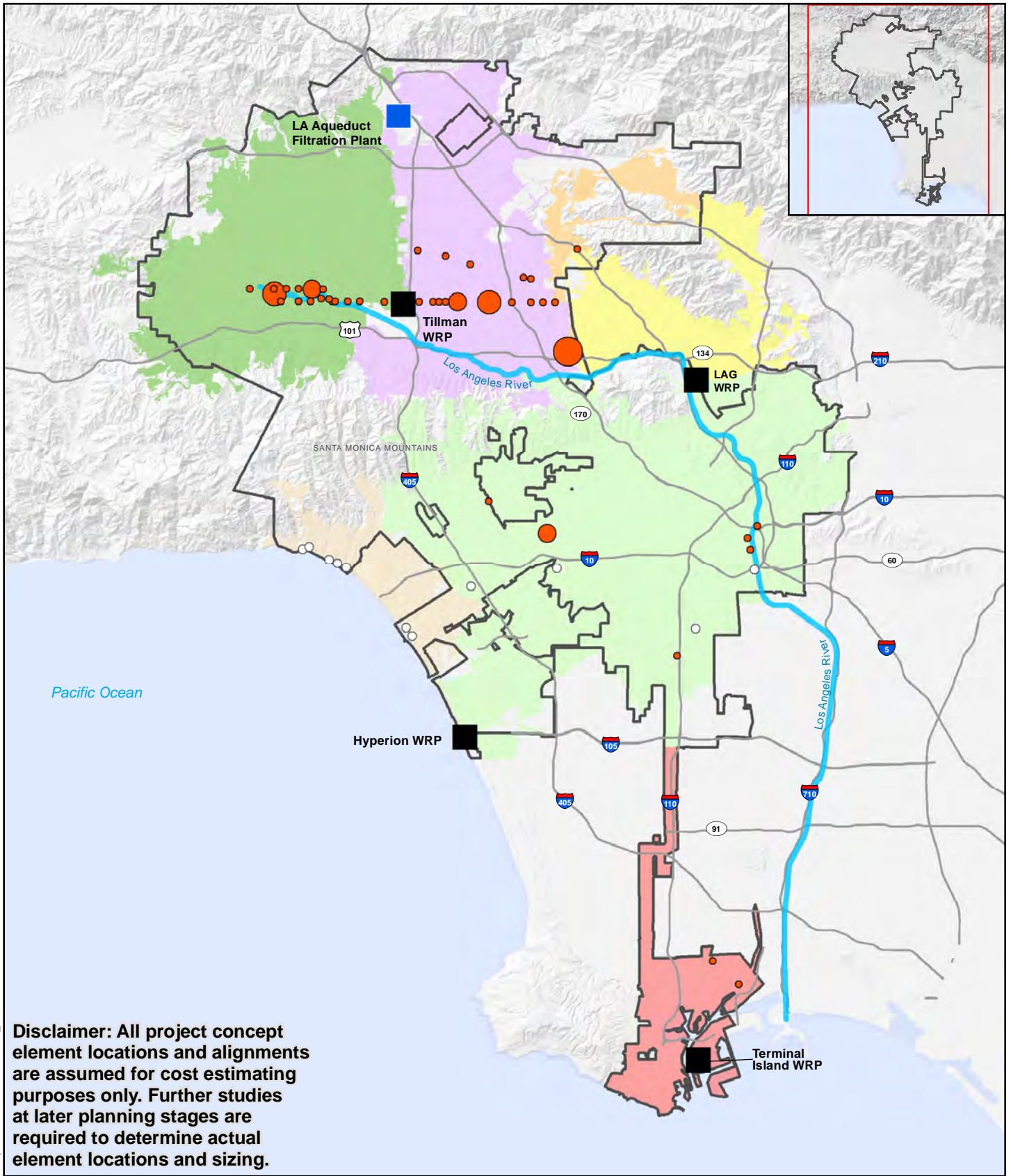

Disclaimer: All project concept element locations and alignments are assumed for cost estimating purposes only. Further studies at later planning stages are required to determine actual element locations and sizing.

Legend

- Existing Water Reclamation Plant (WRP)
- Existing Water Filtration Plant
- City of Los Angeles

Proposed Low Flow Diversion Locations Inflow (MGD)

- < 0.2
- 0.3 -0.4
- 0.5-0.6
- 0.7-0.8
- >1.0



Hillshade Source: CalAtlas
<http://www.atlas.ca.gov>

Figure ES.4
Low Flow Diversions
 One Water LA 2040 Plan

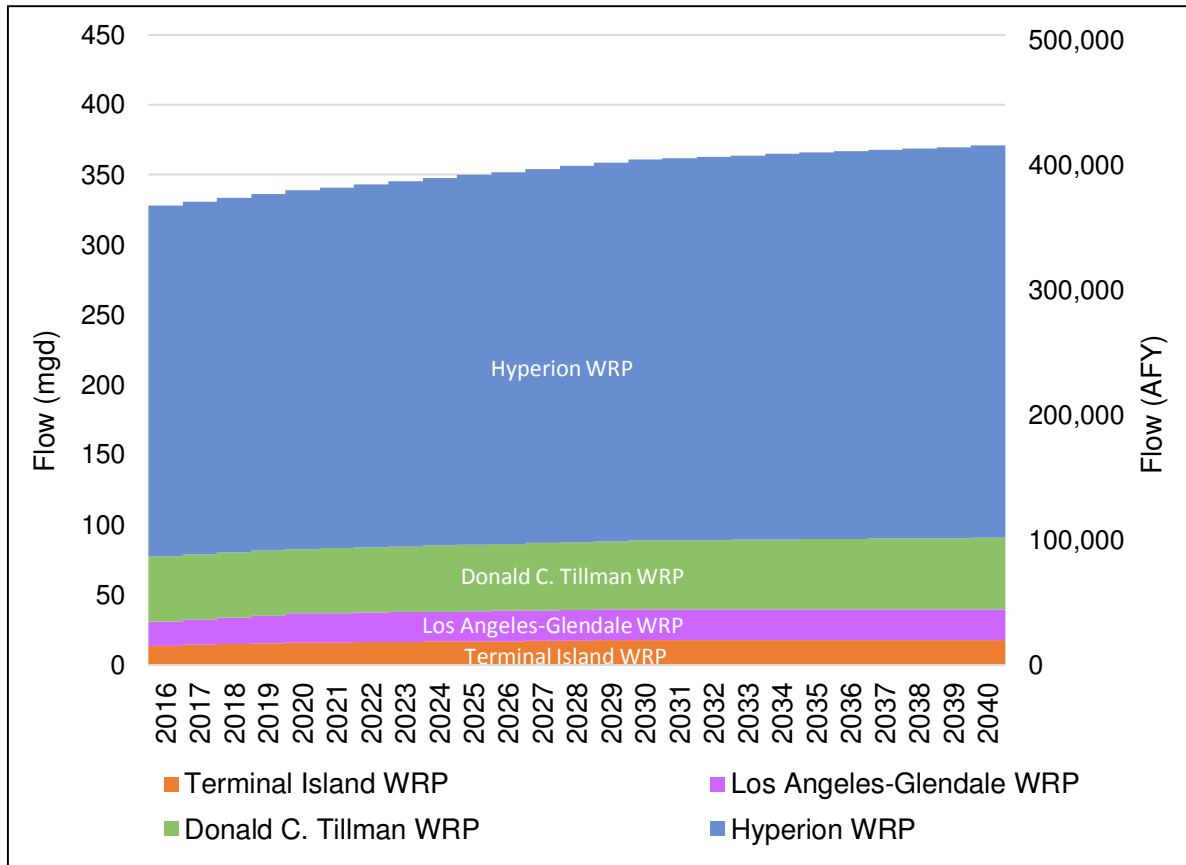

Figure ES.5 Wastewater Flow Projections by WRP

The increased flows that are anticipated to be treated at the inland plants (DCTWRP and LAGWRP) would result in a reduction in the flow that would otherwise be treated at HWRP. The flows to TIWRP are anticipated to increase the least, due to the build out of the sewer collection area, however there are discussions to bring additional sewer flow into the area.

ES.2.3 Non-Potable Reuse

Currently, recycled water is most commonly used for non-potable (not for drinking) purposes, such as agriculture, landscape irrigation, and industrial uses. Other specific non-potable applications include dust control, construction activities, concrete mixing, parks, golf courses, and artificial lakes. The use of non-potable water reduces the amount of potable water used for the aforementioned purposes and thereby reduces the City's reliance on imported water. Non-potable reuse must be compliant with regulations set forth in California Code of Regulations Title 22 (Title 22), which specifies the allowed uses of recycled water at various treatment levels. The current effluent quality at DCTWRP, LAGWRP, and TIWRP meets these standards. Effluent from TIWRP is of advanced water treatment (AWT) quality.

ES.2.4 Potable Reuse

Potable reuse can be distinguished as three types:

- Potable reuse with groundwater augmentation - Projects that would spread (infiltrate) or directly inject recycled water into a groundwater basin that could be used as potable water after extraction and further treatment.
- Potable reuse with raw water augmentation prior to delivery - Projects that would deliver advanced treated recycled water (purified water) to a conventional water treatment plant before distributing into a potable water system.
- Potable reuse with treated water augmentation prior to delivery into the potable water distribution system - Projects that would deliver advanced treated recycled water (purified water) directly to a potable water system.

ES.2.5 Regulatory Drivers

Regulations affecting water reclamation plants are established by a variety of agencies, such as the US Environmental Protection Agency (EPA), Los Angeles Regional Quality Water Control Board (RWQCB-LA), Division of Drinking Water (DDW), and the South Coast Air Quality Management District (SCAQMD).

U.S. EPA delegates the regulatory oversight to the DDW and the RWQCB-LA. The RWQCB-LA issues permits for the WRPs. A National Pollution Discharge Elimination System (NPDES) permit, which governs the discharge from the existing WRPs is issued by the RWQCB-LA. An NPDES permit can contain discharge requirements for total maximum daily loads (TMDLs), sanitary sewer overflow (SSO) controls, and various regulations for receiving waters and recycled water specific to the water body.

LASAN has water reuse programs at each of its four water reclamation plants. As previously stated, these regulations are governed by the DDW and the RWQCB-LA in the California Code of Regulations Title 22, Division 4, and Chapter 3 (Title 22). These regulations establish required treatment levels and water quality levels dependent upon the end use of recycled water.

In addition to the regulations that have been established, the changing regulatory environment has the ability to impact the WRPs. Table ES.2 summarizes potential regulatory drivers that may impact each of the water reclamation plants. This list is not intended to be exhaustive of every possibility, but instead provides an overview of which plants could potentially be impacted as a result of potential future regulations. Details of these potential drivers are summarized in the WWFP (See Volume 2 of this Plan).

Table ES.2 below shows that all four water reclamation plants could be impacted if regulations governing the discharge of brine are passed. Also, all four water reclamation plants would require upgrades should the potable reuse regulations be approved and potable reuse is subsequently implemented by LASAN. The listed potential SCAQMD regulations would only apply to HWRP and TIWRP where solids are processed and methane gas could be produced.

| Table ES.2 Future Regulatory Drivers for WRP Planning Wastewater Facilities Plan One Water LA 2040 Plan | | | | | |
|--------------------------------------------------------------------------------------------------------------------------------------------------------------------------------------------------------|-----------------------------------------------------------------------------------------------------------------------------------------------------------------------------------------------------------------------------------------------------------------------------------------------------------------------------------------------------------------|-------------|---------------|---------------|--------------|
| Potential Drivers | Potential Process(es) Requirement | HWRP | DCTWRP | LAGWRP | TIWRP |
| Potable Reuse | | | | | |
| Treated Water Augmentation | Install advanced treatment process such as Ozone, BAC, MF, RO, UV-AOP | X | X | X | X |
| Increased Nitrogen standards for discharge to inland waters | Enhancement of nitrogen removal processes, increase in peak flow detention time through equalization, optimization of the activated sludge systems or installation of MBR or a combination of the above and research of alternative treatment technologies for the more stringent nitrogen standard | | X | X | |
| Nitrogen standards for Ocean discharge | Requires the implementation of an improved biological system, to produce an effluent with low nitrogen levels and adaptability for potable reuse. Includes evaluation of the current HPO system to achieve compliance with the new standards and potential conversion to a biological process utilizing air and covered aeration tanks with spent air treatment | X | | | X |
| Increased SCAQMD Emission Standards for methane and NOX | Installation of gas cleanup and low emission flares to meet lower NOX standards | X | | | X |
| Brine disposal regulations | Installation of Zero Liquid Discharge, deep well injection | X | X | X | X |
| Abbreviations: | | | | | |
| BAC = biologically activated carbon, MF =microfilter, RO = Reverse osmosis, UV-AOP = ultraviolet advanced oxidation process, MBR = membrane bioreactor, HPO = High purity oxygen, NOX = Nitrogen oxide | | | | | |

ES.3 WASTEWATER COLLECTION SYSTEM

The existing wastewater collection system as well as the planned near-term and long-term wastewater collection system improvements are described in the following subsections. Details of these improvements can be found in the Wastewater Collection System (Chapter 3 of this Volume).

ES.3.1 Existing Collection System

Wastewater is conveyed throughout the sewersheds by an extensive collection system comprised of a network of underground sewer pipes, trunk mains, and pump stations, leading to one or more of the WRPs. The wastewater collection system's physical structure includes major interceptors and mainline sewers, inspection and maintenance access points, pumping plants, various diversion structures, odor control facilities and other support facilities, including mobile and fixed maintenance units.

The City has a number of large, major trunklines that connect the various sewersheds. The entire sewer collection system consists of more than 6,700 miles of pipeline, 43 pumping plants, and 19 major outfall diversion structures. Due to topography, the majority of the sewer flows are conveyed by gravity to the four WRPs.

Some of the sewer flows tributary to DCTWRP and LAGWRP can be diverted to HWRP. In addition, residual waste streams from DCTWRP and LAGWRP are discharged back into the collection system for treatment at HWRP. The daily flows that are treated at these two inland plants are dictated by operational conditions and recycled water demands, which vary seasonally. Effluent from DCTWRP and LAGWRP that is not reused is discharged to the Los Angeles River. Effluent from HWRP that is not sent to West Basin Municipal Water District (WBMWD) is discharged to the ocean through a 5 mile outfall. The majority of the effluent from TIWRP is recycled, but a portion may be discharged to the Harbor under certain discharge permit conditions.

ES.3.2 Near-Term Planned Collection System Improvements

LASAN does routine maintenance and rehabilitation of the wastewater collection system and maintains a running list of capital improvement projects that are prioritized and budgeted. In addition to regular replacements and upgrades, LASAN has a four major improvements planned in the near-term, as summarized in Table ES.3.

| Table ES.3 Near-Term Wastewater Collection System Improvements Wastewater Facilities Plan One Water LA 2040 Plan | |
|---------------------------------------------------------------------------------------------------------------------------------|----------------------------------------------------------------------------------------------------------------------------------------------------------------------------------------------------------------------------------------------------------------------------------------------------------------------------------------|
| Project | Description |
| LAGWRP Primary Effluent Equalization Storage | This project will construct one 2.5-million gallon primary effluent storage tanks for flow equalization, two 24-inch pipelines, two primary tanks, three aeration tanks, two secondary clarifiers at the LAGWRP. This storage tank will relieve the North Outfall Sewer (NOS) by attenuating peak flows in the system through storage. |
| NOS Rehabilitation | The City plans to expedite 18 NOS rehabilitation projects. The City will also assess and rehabilitate 16 miles upstream of Valley Spring Lane and Foreman Avenue using CCTV and laser and sonar profiling. |
| Venice Pumping Plant Dual Force Main | This project will construct a second force main sewer to operate in conjunction with the existing force main in order to meet existing peak wet weather flow demands, provide isolation for cleaning and maintenance, and allow for operational flexibility and reliability. |
| Venice Auxiliary Pumping Plant | This project will provide a new pumping plant adjacent to the existing Venice Pumping Plant, a new electrical building, and a new generator. Additionally, this project will provide site security and control capabilities for both the existing and new auxiliary plant. |

The projects summarized in Table ES.3 are anticipated to be implemented within the near-term planning horizon and have been incorporated into the CIP.

ES.3.3 Long-Term Collection System Improvements

In anticipation of future flows, LASAN has currently identified one major conveyance project for the future, namely the San Fernando Relief Sewer. This project would consist of approximately 4 miles of 48-inch diameter sewer to provide redundancy to the North Outfall Sewer (NOS). The relief sewer would also provide capacity to facilitate a shutdown of the LAGWRP during a storm event, if necessary.

Other collection system improvement projects have been identified by LASAN to appropriately plan and budget for the 2040 planning horizon. These projects are included in the CIP discussed in Section ES.8.

ES.4 WATER RECLAMATION PLANTS

As described previously, the City owns and operates the following four water reclamation plants:

1. **HWRP.** This plant is located in Playa del Rey along the Pacific Ocean, just south of the Los Angeles International Airport (LAX);
2. **DCTWRP.** This plant is located in the San Fernando Valley, in the Sepulveda Basin;
3. **LAGWRP.** This plant is located east of Interstate 5 (I-5), east of Griffith Park, and is co-owned with the City of Glendale;
4. **TIWRP.** This plant is located on an island in the Los Angeles Harbor, approximately 20 miles south of downtown Los Angeles.

The treatment process, design capacity, and average flow (2016) of each plants' treated effluent is summarized in Table ES.4. Existing and future facilities at each plant are described in greater detail in subsequent sections of this executive summary.

| Table ES.4 Water Reclamation Plant Summary Wastewater Facilities Plan One Water LA 2040 Plan | | | |
|--------------------------------------------------------------------------------------------------------------------------------------------------------------------------------------------------------------------|-------------------------------------------------------------------------------------------------|------------------------------------------------|-----------------------------------------------------|
| Water Reclamation Plant | Treatment Process Train | Average Dry Weather Flow Capacity (mgd) | Average Dry Weather Flow (mgd)⁽³⁾ |
| HWRP | Secondary treatment ⁽¹⁾ | 450 | 250 |
| DCTWRP | Tertiary treatment ⁽²⁾ following activated sludge (AS) nitrification denitrification | 80 | 47 |
| LAGWRP | Tertiary treatment following AS nitrification denitrification | 20 | 17 |
| TIWRP | Tertiary treatment following AS nitrification and | 30 | 14 |
| | Advanced water purification treatment | 12 | 2.4 |
| Notes: | | | |
| (1) Secondary Treatment is defined as removal of biodegradable organic matter and suspended solids. | | | |
| (2) Tertiary Treatment is defined as the removal of residual solids (following secondary treatment) through the use of granular medium filtration or microscreens. Disinfection is also part of tertiary treatment | | | |
| (3) mgd = million gallons per day, 2016 annual average flow | | | |

The following subsections summarize the characteristics of each of the four WRPs, while additional information is included in the WWFP.

ES.4.1 HWRP

HWRP is the City's oldest and largest water reclamation plant in Los Angeles. The plant is bounded by Imperial Highway on the north, Vista Del Mar on the west, Scattergood

Generating Station (SGS) on the south, and the City of El Segundo on the east. Located within the Hyperion Service Area, HWRP treats wastewater from a tributary area of approximately 515 square miles. HWRP also receives and treats process residual flows from DCTWRP, LAGWRP, the Burbank Water Reclamation Plant (BWRP), and the Los Angeles Zoo Treatment Facility (LAZTF).

HWRP is rated and permitted to treat an average flow of 450 mgd and a peak wet weather flow of 850 mgd. However, with the success of water conservation and substantially decreased sewer flows, average flows in 2016 were 250 mgd. Currently, HWRP is operated as a full secondary treatment facility utilizing high purity oxygen activated sludge process. After treatment, a majority of the effluent is discharged to Santa Monica Bay through a 5 mile long outfall, terminating at a depth of 200 feet. The remaining effluent is pumped to WBMWD for additional treatment dependent upon reuse demand. As shown on Figure ES.6, the treatment process at HWRP consists of preliminary, primary, and secondary treatment. A more detailed process flow diagram for HWRP is provided in Chapter 4 of the WWFP.

HWRP has a contractual partnership with WBMWD to send a portion of the HWRP effluent to WBMWD's Edward C. Little Water Recycling Facility (ECLWRF), which provides additional treatment to produce various qualities of recycled water to customers in the south bay, the west side, and parts of the Los Angeles Harbor. In addition, a portion of the effluent is treated at the Service Water Facility at HWRP for use within the plant.

HWRP has state of the art solids processing units using thermophilic anaerobic digestion for organics stabilization, pathogen reduction, and the production of biogas and treated solids for reuse. LASAN has recently completed the Hyperion Bio-Energy Facility (HBEF) to use HWRP's digester biogas for renewable energy generation. The treated solids can be beneficially reused through composting or used for agricultural soil enhancement at the City's Green Acres Farm.

Currently, there are a number of ongoing and planned In-Progress Projects at HWRP. The following are the ongoing projects most relevant for the purpose of this Plan:

- **Secondary Treatment Process Upgrade:** Evaluations are underway at the HWRP to assess the feasibility of upgrading a portion of secondary treatment to deliver higher quality effluent and increased quantities (up to 70 mgd) to WBMWD. As part of this evaluation, HWRP staff is considering the implementation of a Pilot Test Facility to determine the scalability of a membrane bioreactor (MBR) system and to optimize downstream processes.
- **Los Angeles Wastewater Integrated Network System (LAWINS):** The City is in the process of updating the distributed control system that will allow the four WRPS and pumping plants to be effectively and efficiently controlled as one system.

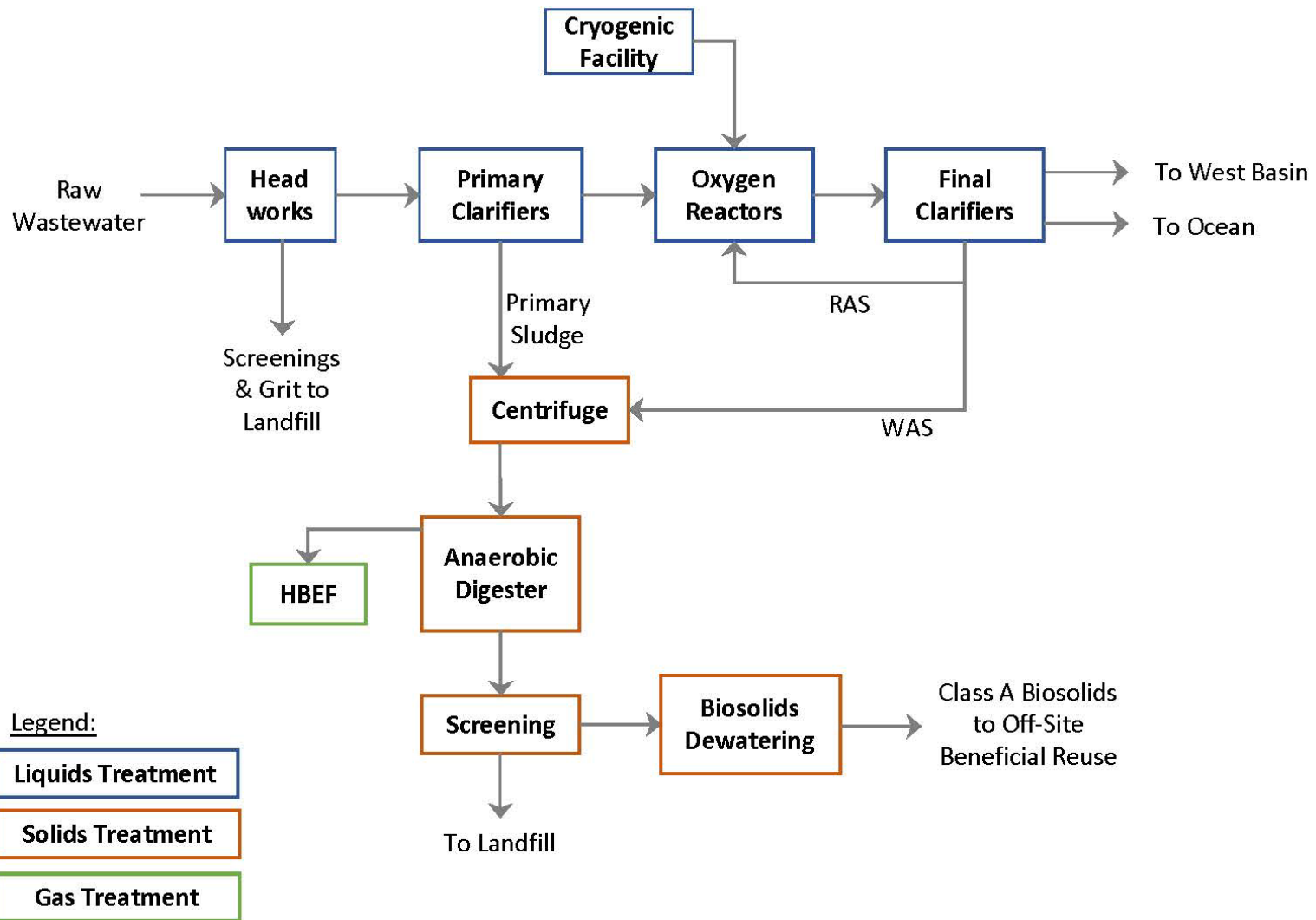

Figure ES.6
 Process Flow Diagram for HWRP
 One Water LA 2040 Plan



In-Progress Projects are planned projects that are expected to be implemented outside and independent of the One Water LA 2040 Plan. More information on In-Progress Projects is found in Volume 1, Chapter 6. The In-Progress Projects for HWRP are:

- **Advanced Treated Recycled Water Delivery to LAX and Scattergood Generating Station (In-Progress Project #5):** The City is in the process of implementing a 1.5 mgd advanced water treatment facility serving Los Angeles International Airport, SGS, and HWRP internal users. The facility could be expanded an additional 3.5 mgd, for a total capacity of 5 mgd, in the future.
- **HWRP Delivery Expansion to 70 mgd for West Basin Municipal Water District and LA Harbor Area (In-Progress Project #6):** WBMWD and HWRP are in the process of expanding this pump station for delivery of up to 70 mgd of secondary effluent to WBMWD.

The potential future plant modifications to maximize water reuse opportunities are discussed in Section ES.5.

ES.4.2 DCTWRP

DCTWRP is a full tertiary treatment facility located in the San Fernando Valley. The plant is located on a 91-acre site within the Sepulveda Control Basin in Van Nuys, south of Victory Boulevard, between Woodley Avenue and the San Diego Freeway (Interstate 405). DCTWRP was built in two phases, each with a capacity of 40 mgd. Hence, the plant is rated and permitted to treat an average flow of 80 mgd, and a peak wet weather flow of 160 mgd. However, water conservation has resulted in substantially decreased sewer flows, 47 mgd in 2016, so that only one phase of the plant is currently operated.

As shown on Figure ES.7, DCTWRP provides primary, secondary, and tertiary treatment with disinfection. Side streams, including residuals and any by-passed flow from the treatment processes are returned to the sewer system for treatment at HWRP. The plant effluent is compliant with Title 22 standards for non-potable reuse, and the majority of the effluent flows through Balboa Lake, Wildlife Lake, DCTWRP's Japanese Garden, and to the Los Angeles River. A more detailed process flow diagram and discussion of existing treatment processes for DCTWRP can be found in Chapter 5 of the WWFP.

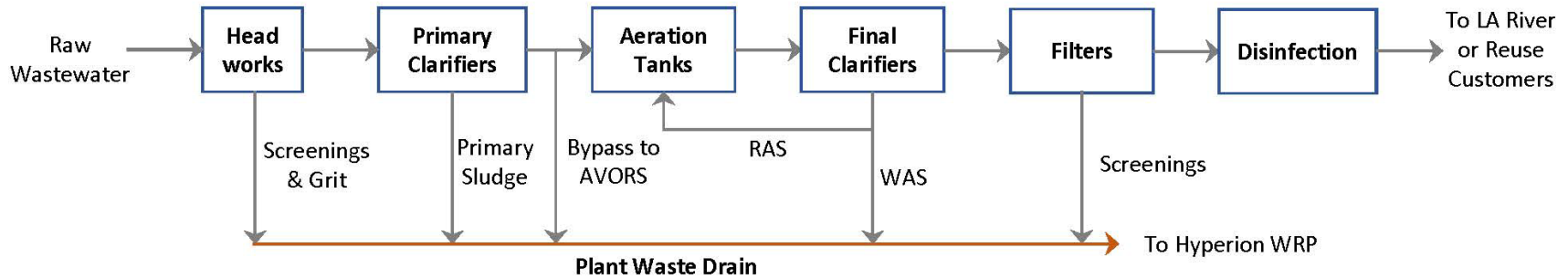

Legend:

Liquids Treatment

Solids Treatment

Figure ES.7
Process Flow Diagram for DCTWRP
 One Water LA 2040 Plan



Currently, there are a number of ongoing and In-Progress Projects at DCTWRP including the following ongoing projects:

- **Ozone Demonstration Project:** The City is implementing a demonstration project consisting of a 7-10 mgd interim ozonation system to provide ozonated tertiary treated recycled water for spreading at the Hansen Spreading Grounds. This demonstration project will provide data regarding soil aquifer treatment and aid in the development of a larger recharge program.
- **LAWINS:** The City is in the process of updating the distributed control system that will allow the four water reclamation plants and pumping plants to be effectively and efficiently controlled as one system.

The In-Progress Project for DCTWRP consists of:

- **Groundwater Replenishment Project with Advanced Water Purification Facility (AWPF) at DCTWP (up to 30,000 AFY in San Fernando Basin) (In-Progress Project #2):** DCTWRP is adding an AWPF to the plant yielding purified water for groundwater recharge at the Hansen and Pacoima Spreading Grounds. The purpose of this Groundwater Replenishment (GWR) project is to recharge the San Fernando Basin and ultimately increase the amount of local water supply to meet the City's water supply reliability goals.

The potential future plant modifications to maximize water reuse opportunities are discussed in Section ES.5.

ES.4.3 LAGWRP

LAGWRP is located in the City of Glendale, across the Golden State Freeway from Griffith Park, and serves eastern San Fernando Valley communities. The plant is co-owned by the cities of Los Angeles and Glendale and operated by LASAN. LAGWRP provides preliminary, primary, secondary, and tertiary treatment, followed by disinfection. LASAN and the City of Glendale equally share in the cost of the plant operation and thus have an equal share in the recycled water that is produced.

LAGWRP is rated and permitted to treat an average flow of 20 mgd, and a peak wet weather flow of 30 mgd. However, water conservation has resulted in substantially decreased sewer flows with average flows in 2016 of 17 mgd. The plant effluent is compliant with Title 22 standards for disinfected tertiary recycled water and is pumped to either the non-potable recycled water distribution system or flows by gravity to the Los Angeles River. All solids removed from the treatment process are returned untreated to the NOS for conveyance to HWRP for downstream treatment.

A schematic of the treatment process at LAGWRP is shown on Figure ES.8. A more detailed process flow diagram for LAGWRP can be found in Chapter 6 of the WWFP.

Currently, there are a number of ongoing and planned In-Progress Projects at LAGWRP. The following projects are ongoing:

- **Primary Effluent Equalization Storage:** As discussed in Section ES.3.2, the plant is in the process of implementing one 2.5-million gallon primary effluent storage tanks for flow equalization, two 24-inch pipelines, two primary tanks, three aeration tanks, two secondary clarifiers. This storage tank will relieve the NOS by attenuating peak flows in the system through storage.
- **LAWINS:** The City is in the process of updating the distributed control system that will allow the four water reclamation plants and pumping plants to be effectively and efficiently controlled as one system.

The In-Progress Project for LAGWRP is:

- **Expansion of NPR per 2015 UWMP (In-Progress Project #4):** LAGWRP currently meets all recycled water demands in the -Metro Area and would continue to do so for the additional customer demand identified by this project.

The potential future plant modifications to maximize water reuse opportunities are discussed in Section ES.5.

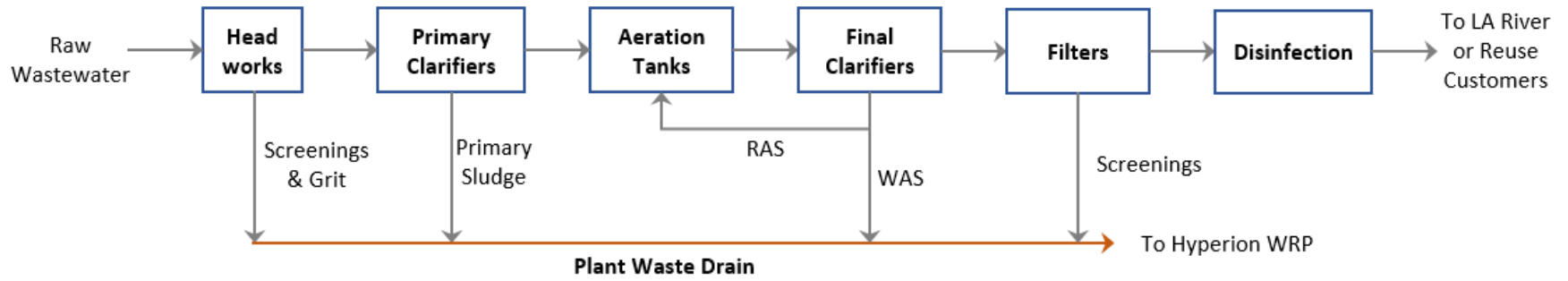

Legend:



Figure ES.8
Process Flow Diagram for LAGWRP
 One Water LA 2040 Plan

ES.4.4 TIWRP

TIWRP is located on Terminal Island, in Los Angeles Harbor approximately 20 miles south of downtown Los Angeles. The plant is within a 21.5-acre site at the northwest corner of Terminal Way and Ferry Street. TIWRP treats wastewater from throughout the TISA, consisting of flows from municipal, commercial, and industrial facilities. Similar to HWRP, TIWRP processes all of its residual solids from treatment processes on site.

TIWRP has the permitted capacity to provide tertiary treatment for an average dry weather flow of 30 mgd and peak wet weather flow of 55 mgd. The 2016 average flow is 14 mgd. The AWPf recently completed an expansion (In-Progress Project #3) to increase its capacity from 6 mgd to 12 mgd. This expansion included the addition of a 2 MG tertiary equalization tank, additional microfiltration units, reverse osmosis and an advanced oxidation process. This expansion was completed during the development of the WWFP. Effluent is primarily reused for recycled water customers and injection into the Dominguez Gap Barrier.

As shown on Figure ES.9 treatment process at TIWRP consists of preliminary, primary, secondary, tertiary, and advanced treatment. Additional discussion of treatment processes at TIWRP's can be found in Chapter 7 of the WWFP, along with a more detailed process flow diagram.

There are a number of ongoing and planned In-Progress projects at TIWRP. The LAWINS program is an ongoing project being implemented at TIWRP. The In-Progress Project for TIWRP is:

- **Expansion of NPR per 2015 UWMP (In-Progress Project #4):** The UWMP estimated 12,820 AFY of additional recycled water demand in the Harbor Area, some of which would be supplied by TIWRP. Implementation of this project would not require changes to the plant once the expansion of the AWPf is complete.

The potential future plant modifications to maximize water reuse opportunities are discussed in Section ES.5.

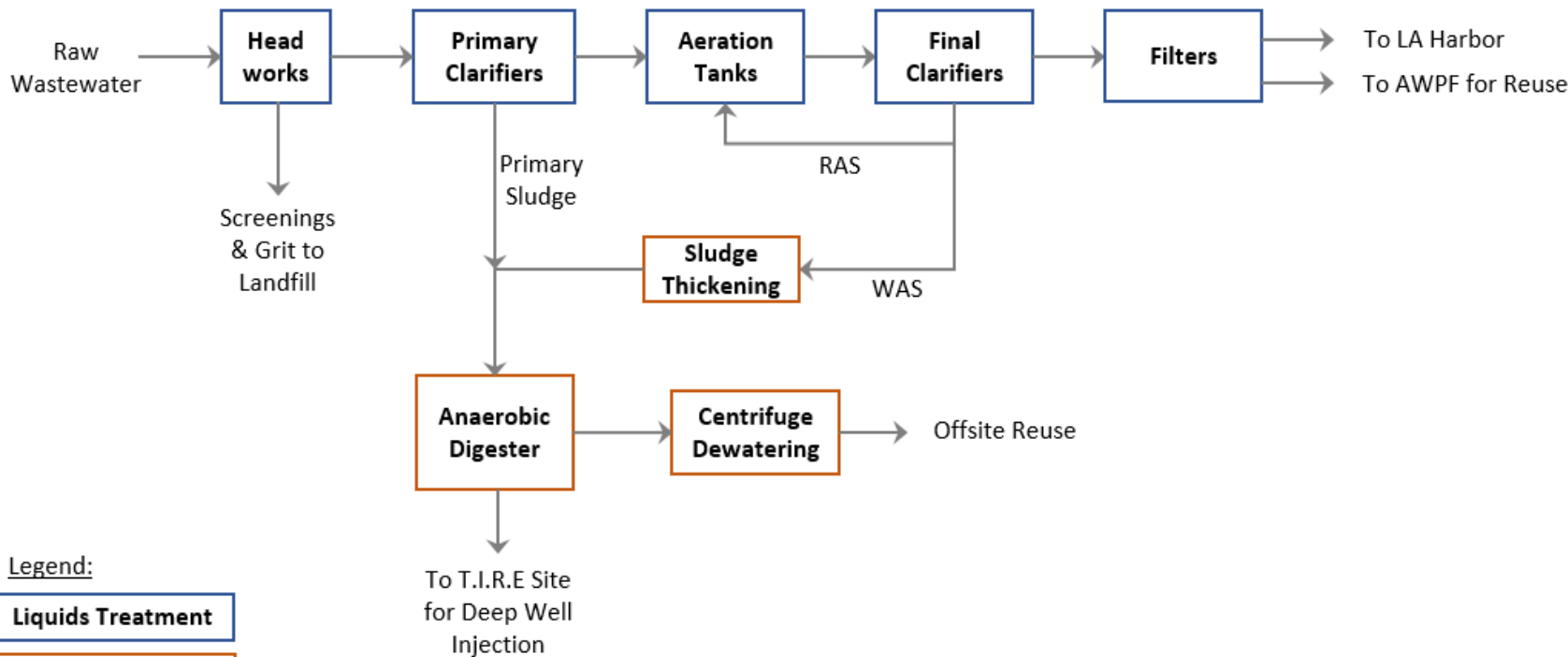

Figure ES.9
Process Flow Diagram for TIWRP
 One Water LA 2040 Plan



ES.5 FUTURE WASTEWATER SYSTEM ANALYSIS

Through a series of workshops, stakeholder meetings, and engagement with the One Water LA team, a total of 27 new concept options were identified that could increase local supply availability and achieve water quality goals through collaborative projects involving multiple city departments and/or regional agencies. Each of the 27 concept options was developed, evaluated, scored, and ranked as described in Chapter 6 (see Volume 1). The 17 concept options that involved water reuse at the WRPs are summarized in Table ES.5.

| Table ES.5 Water Reuse Concept Options Wastewater Facilities Plan One Water LA 2040 Plan | | |
|---------------------------------------------------------------------------------------------------------|------------------------|-------------------------------------------------------|
| Strategy | #⁽¹⁾ | Name |
| LA River Storage and Use | 7 | Upper Los Angeles River to DCTWRP |
| | 9 | DCTWRP to San Fernando Basin Injection Wells |
| Potable Reuse with Groundwater Augmentation | 10 | HWRP to West Coast Basin Injection Wells |
| | 11 | HWRP to Central Basin Injection Wells |
| | 12 | HWRP to Central Basin with Spreading Basins |
| | 13 | MBR at HWRP to Regional System |
| | 14 | HWRP to San Fernando Basin Injection Wells |
| Potable Reuse with Raw Water Augmentation | 15 | DCTWRP to Los Angeles Aqueduct Filtration Plant |
| | 20 | HWRP to Los Angeles Aqueduct Filtration Plant |
| Potable Reuse with Treated Water Augmentation | 16 | DCTWRP to LADWP Distribution System |
| | 17 | LAGWRP to Headworks Reservoir |
| | 18 | HWRP to LADWP Distribution System |
| | 19 | HWRP to Headworks Reservoir |
| Non-Potable Reuse | 23 | Increase Recycled Water Demand beyond 2015 UWMP |
| | 24 | Rancho Park Water Reclamation Facility |
| Flow Management | 22 ⁽²⁾ | East-West Valley Interceptor Sewer |
| | 26 ⁽²⁾ | Japanese Garden & Sepulveda Basin Lakes Recirculation |
| Notes: | | |
| (1) The numbering is intentionally out of order due to the grouping by Strategy. | | |
| (2) These flow management concepts are not a stand-alone strategy. | | |

As part of the WWFP development, each of the 17 concept options listed in Table ES.5 was reviewed to identify improvements that would need to be implemented at the corresponding

water reclamation plants as well as system changes to convey that product water. This analysis included preliminary sizing of treatment process modifications, location of the processes, and preliminary cost estimates. Based on the overall concept score, cost estimates, and portfolio evaluation results, the concept options were prioritized for each plant. As the flows from each plant can only be utilized once, it is important to identify what the most beneficial method of water reuse is for each plant. However, implementing many concept options are dependent on certain triggers, such as regulatory conditions or institutional arrangements and more detailed feasibility studies.

As a result, the highest scoring concept option may not be viable depending on which triggers may or may not occur in the future. A more detailed discussion of the concept option scoring and portfolio evaluation results is included in Chapter 6 (see Volume 1).

To guide the City with prioritization and the decision-making process related to these future water reuse options, a trigger-based implementation strategy was developed for each WRP and is shown on subsequent figures.

As shown in each of these figures, there are multiple water reuse options included for most of the WRPs. The most preferred concept option is indicated as "Priority A", while the next best concept option is identified as "Priority B" and third best as "Priority C". It should be noted that the priorities can change in the future as the underlying conditions, assumptions, and triggers may change in the future. Hence, it is critical that the City reconsider the benefits of all concept options when deciding to move forward with the implementation of any of these concept options. A summary of triggers is provided in Chapter 10 (see Volume 1).

The preferred concept options that were identified using the triggers were incorporated into the WWFP Adaptive Capital Improvement Plan. The CIP is described in Section ES.8 of this chapter. Further details on the development of concept options and the evaluation process can be found in Chapter 6 (see Volume 1).

The following subsections first present the concept options for each WRP, then a trigger-based implementation strategy for each WRP, and lastly describe the concept options by priority.

ES.5.1 HWRP

Eight concept options involving potable reuse with groundwater augmentation, potable reuse treated water augmentation and potable reuse with raw water augmentation. Table ES.6 presents the priority of water reuse from HWRP based on the concept option evaluation and scoring results and Figure ES.10 presents a trigger-based implementation strategy for HWRP future concept options.

| Table ES.6 HWRP Concept Options Wastewater Facilities Plan One Water LA 2040 Plan | | | | | |
|--------------------------------------------------------------------------------------------------------------------------------------------------------------------------------------------------------------------------------------------------------------------------------------------------------------------------------------------------------------------------------------------------------------------------------------------------------------------------------------------------------------------------|-----------------------------------------------|----------------------------------------------------|--------------------------------------|-----------------------------------------|--------------------------|
| Concept Option # | Title | Strategy | Estimated Yield (Normal Year) | Capital Cost (\$M)⁽¹⁾ | Unit Cost (\$/AF) |
| 10 | HWRP to West Coast Basin Injection Wells | Potable Reuse with Groundwater Augmentation | 20,000 AFY (18 mgd) | \$900 | \$3,200 |
| 11 | HWRP to Central Basin Injection Wells | Potable Reuse with Groundwater Augmentation | 75,000 AFY (70 mgd) | \$3,300 | \$2,700 |
| 13 | MBR at HWRP to Regional System | Potable Reuse with Groundwater Augmentation | 95,000 AFY (85 mgd) | \$900 | \$1,500 |
| 14 | HWRP to San Fernando Basin Injection Wells | Potable Reuse with Groundwater Augmentation | 20,000 AFY (18 mgd) | \$680 | \$2,400 |
| 18 | HWRP to LADWP Distribution System | Potable Reuse with Treated Water Augmentation | 95,000 AFY (85 mgd) | \$2,800 | \$2,100 |
| 19 | Hyperion WRP to Headworks Reservoir | Potable Reuse with Treated Water Augmentation | 95,000 AFY (85 mgd) | \$3,200 | \$2,400 |
| 20 | HWRP to Los Angeles Aqueduct Filtration Plant | Potable Reuse with Raw Water Augmentation | 95,000 AFY (85 mgd) | \$3,600 | \$2,600 |
| <p><u>Note:</u></p> <p>(1) Total Concept Option cost includes a variety of project components including treatment facilities, conveyance, and injection and extraction facilities. Not all costs pertain to the Wastewater Facilities Plan.</p> <p>(2) Bold indicates a Priority A Concept Option</p> <p>(3) Concept Option #12 was determined to have a fatal flaw resulting from 1) a lack of capacity in the existing Rio Hondo Spreading Grounds and 2) a lack of vacant land to construct new spreading basins.</p> | | | | | |

Hyperion Water Reclamation Plant

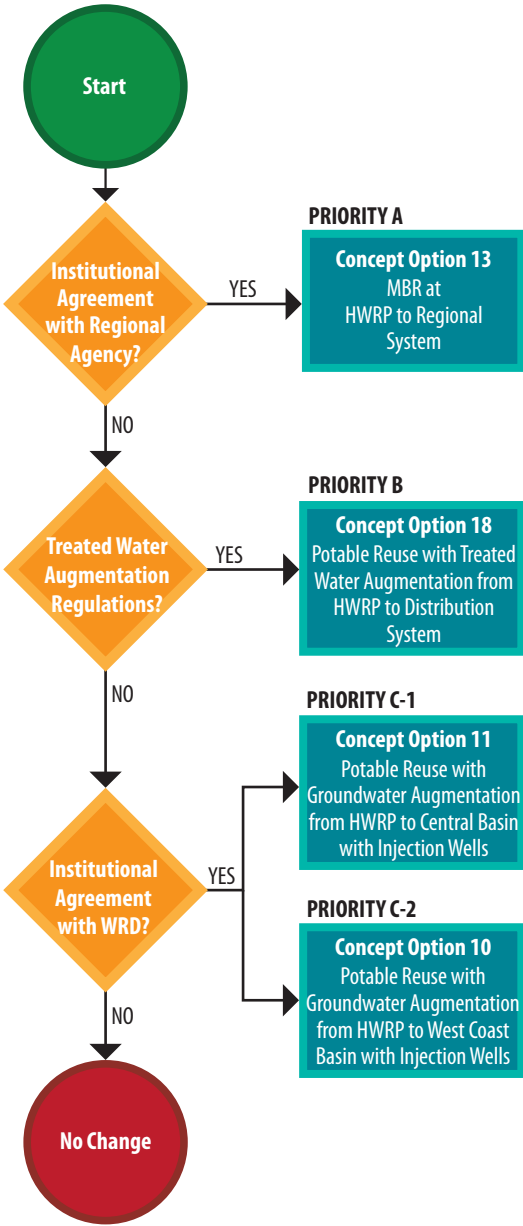

LEGEND & ACRONYMS

- ◆ Trigger
- Concept Option
- Flow Management Option

| | |
|--------|-----------------------------------------------------|
| DCTWRP | Donald C. Tillman Water Reclamation Plant |
| GWR | Groundwater Replenishment Project |
| HWRP | Hyperion Water Reclamation Plant |
| LAGWRP | LA-Glendale Water Reclamation Plant |
| RWQCB | Regional Water Quality Control Board |
| TIWRP | Terminal Island Water Reclamation Plant |
| WRD | Water Replenishment District of Southern California |

Disclaimer: At each trigger (decision point), evaluate all triggers and concept option priorities to consider changed circumstances in the future.

Figure ES.10
Trigger-Based Implementation Strategy for HWRP
One Water LA 2040 Plan
Summary Report

As shown on Figure ES.10, the most critical trigger to implement the Priority A Concept Option #13 (MBR at HWRP to Regional System) is establishing an institutional agreement with a regional project partner, such as Metropolitan Water District (MWD), the Water Replenishment District (WRD), LACSD, and/or WBMWD. If such an agreement does not materialize, the Priority B and C options could also be considered.

The most critical trigger for the Priority B Concept Option #18 (HWRP to LADWP Distribution System) is adopting potable reuse with treated water augmentation regulations that would allow this type of water reuse practice. If the potable regulations are not accepted within a desired timeframe, or if the City prefers a more conventional form of water reuse, the third-best potable reuse options from HWRP are Concept Options #10 and #11. These options consist of groundwater augmentation in the West Coast and Central Basin, respectively. Both options require an institutional agreement with WRD, who acts as the Watermaster for these two groundwater basins. In case such an agreement does not materialize and potable reuse regulation are not approved, it is recommended to postpone the implementation of a large scale potable reuse project from HWRP, which is indicated as "No Change" on Figure ES.10.

It can be concluded that all concept options involve the installation of additional treatment facilities at HWRP to deliver either MBR quality or advanced treated water for the various potable reuse project configurations. In addition, all selected concept options have the same capacity of 95,000 afy. This capacity is based on the estimated available flow from HWRP for future water reuse projects after consideration of existing projects, already planned projects, estimated future flow increases, and treatment losses as shown in Table ES.7 and on Figure ES.11. For concept options #10 and #11, the total available flow of 95,000 afy was proportionally allocated between the Central and West Coast Basins based on the estimated storage capacity of these basins.

| Table ES.7 HWRP Flow Assumptions Wastewater Facilities Plan One Water LA 2040 Plan | |
|---------------------------------------------------------------------------------------------------|--------------------|
| Flow Component | Flow (mgd) |
| HWRP 2040 Project Influent Flow | 283 |
| In-Plant Uses | -36 ⁽¹⁾ |
| Existing Delivery to West Basin | -35 |
| Expanded Delivery to West Basin | -35 |
| Hyperion AWP (HAWPF) | -1.5 up to -5 |
| Expanded DCTWRP Water Reuse | -34 |
| Expanded LAGWRP Water Reuse | -3 |
| Potential Rancho Park WRF | -5 |

| Table ES.7 HWRP Flow Assumptions Wastewater Facilities Plan One Water LA 2040 Plan | |
|-------------------------------------------------------------------------------------------------------------------------------------------------|--------------------|
| Flow Component | Flow (mgd) |
| Brine Loss due to HAWPF (LAWA) | -0.2 up to -0.75 |
| Brine Loss due to potential Advanced Water Purification Facility | -20 ⁽²⁾ |
| Range of Available Flows for Water Reuse | 109-133 |
| Note: | |
| (1) 25 mgd is used once through cooling at the HBEF. 11 mgd is used for other in-plant uses. 36 mgd non-recoverable at this time for recycling. | |
| (2) Based on assumed capacity of 85 mgd per Concept Option #13 | |

A conservative estimate of 85 mgd (95,000 AFY) was used to account for the remaining flows available at HWRP for reuse. This flow may vary due to conservation, and the amount of flow bypassed from the upstream plants. This value was used for the sizing of facilities and equipment that may be needed for each concept option. However, the concept options are preliminary in nature as the projects remain at a high level of definition. Further evaluation would be required should a concept option be implemented.

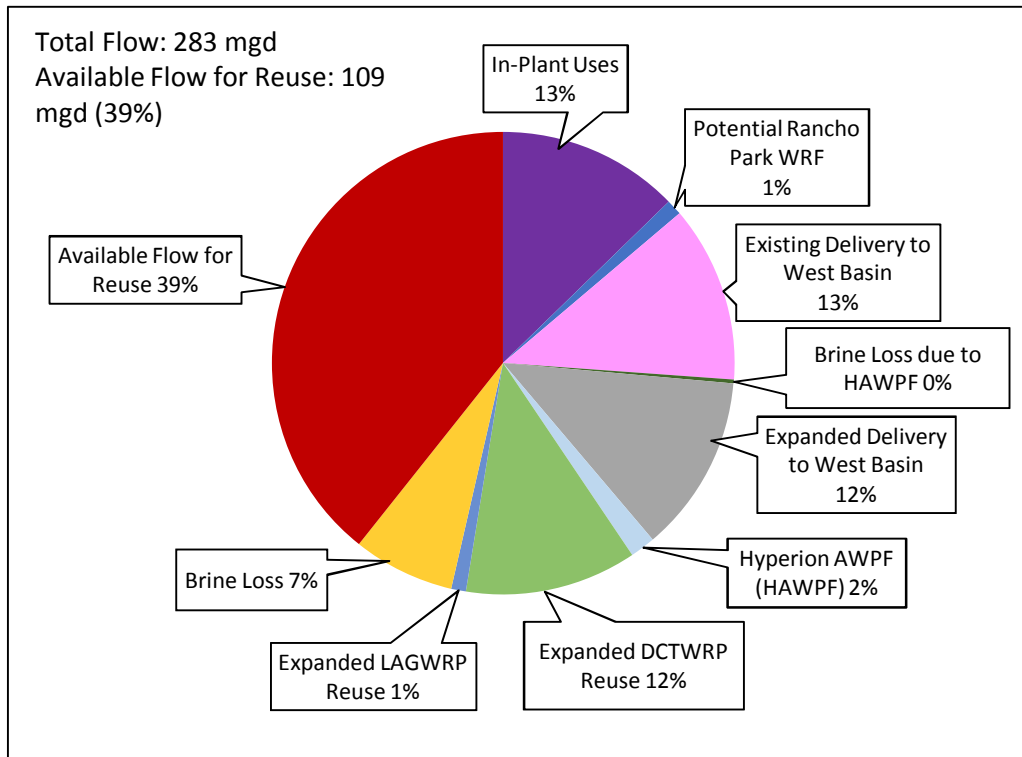

Figure ES.11 Estimated Flow Availability for Water Reuse from HWRP (2040 Projection)

In order to implement Concept Option #13 (MBR at HWRP to Regional System), HWRP process trains may need to be retrofitted for the installation of an MBR with a treatment

capacity of 95,000 AFY (85 mgd). Additionally, it is estimated that a 25-MG primary effluent equalization tank may be required along with a large 13,000 horsepower (hp) pump station and a pipeline for conveyance. The length of the pipeline and pump station location would be determined by the connection location once a service agreement is established. An overall schematic of this concept option is shown on Figure ES.12. The proposed plant modifications to HWRP are shown on Figure ES.13.

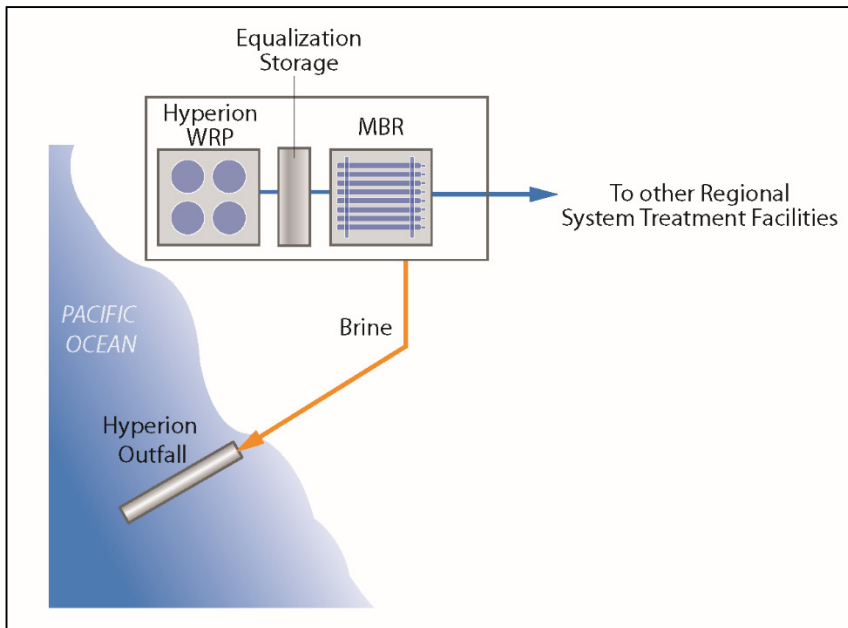

Figure ES.12 Process Flow Schematic for Concept Option #13 (MBR at HWRP to Regional System)

The location of the facilities presented on Figure ES.13 is preliminary in nature as the concept option definition remains at a high level. Details of the optimum project and location within the plant would need to be evaluated should this concept option be implemented.

Concept Option #13 (MBR at HWRP to Regional System) is a Priority A concept option. The key benefits associated with this concept option consist of:

- Maximizing HWRP's flows for reuse reducing discharge to the ocean.
- Promotes collaboration with regional partners
- Delivers water to a regional system for reuse such as recharge into a groundwater basin that may be extracted for potable reuse and sold to water retailers at full service rates.

Moreover, this concept option helps fulfill the following One Water key objectives and guiding principles:

- Implement, monitor, and maintain a reliable wastewater system

- Improve local water supplies reliability
- Integrate management of water resources & policies
- Increase climate resilience

As such, the WRP portion of the concept option cost is included in the WWFP Adaptive CIP. The WWFP Adaptive CIP is discussed in further detail in Section ES.8. Details of lower priority concept options for HWRP are discussed in Appendix C.

Document Path: \\usinv1s01\GIS\GIS_Jobs\City_LA_BOS_MXD\Task7_TM\G\HWRP_PPEB_Metropolitan_20170914.mxd



- Proposed Facility
- Fine Screen
- Hyperion Recycled Water Pump Station
- MBR

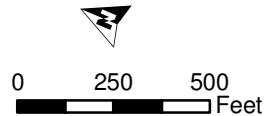

Figure ES.13
Potential Upgrades
 for Concept Option #13
 (MBR at HWRP to Regional
 System)
 One Water LA 2040 Plan

ES.5.2 DCTWRP

Six concept options that involve potable reuse with raw water augmentation, groundwater augmentation, treated water augmentation, LA river storage and use, and flow management from DCTWRP were evaluated. These concept options, shown in Table ES.8 were prioritized and the preferred concept options were identified.

The most critical trigger of any of the Priority A, B, or C options is the ability to increase recycled water flow availability to DCTWRP. Due to the success of water conservation and the ongoing groundwater replenishment project, all existing flows have been accounted for. Hence, the first trigger is a decision to pursue and implement a flow management project to divert additional wastewater flows to DCTWRP. Once the City makes this decision, the next trigger is the approval of a wastewater change petition from the Division of Water Rights per Water Code Section 1211 to allow a reduction in effluent discharge from DCTWRP to the LA River.

If this petition is approved, the City could proceed with Concept Option #26. By implementing some type of flow recirculation project for the Japanese Garden and Sepulveda Basin Lakes, a portion of the DCTWRP effluent that is currently discharged into the LA River could be repurposed for potable reuse.

If this petition is not approved, the City would need to proceed with Concept Option #22 and increase flow availability to DCTWRP by constructing the EWVIS project, which consist of a 6-mile sewer forcemain and six lift stations to bring wastewater flows from the eastern part of the San Fernando Valley to DCTWRP.

As shown on Figure ES.14, the next most critical triggers are related to the adoption of potable reuse regulations. The highest ranked potable reuse opportunity (Concept Option #15 - DCTWRP to LAAFP) would require acceptance of potable reuse with raw water augmentation, while the second highest concept option (#16 - DCTWRP to Distribution System) would require acceptance of potable reuse with treated water augmentation. In case the potable regulations are not accepted within a desired timeframe or if the City prefers a more conventional form of water reuse, the third best potable reuse option from DCTWRP is Concept Option #9 (Groundwater Augmentation from DCTWRP to San Fernando Basin Injection Wells). If none of the of the flow management strategies are feasible nor the potable reuse regulations are approved, it is recommended to postpone any new water reuse projects from DCTWRP. This decision is indicated as "No Change" on Figure ES.14.

| Table ES.8 DCTWRP Concept Options Wastewater Facilities Plan One Water LA 2040 Plan | | | | | |
|-------------------------------------------------------------------------------------------------------------------------------------------------------------------------------------------------------------------------------------------------------------------------------------------------------|--------------------------------------------------------|--------------------------------------------------|--------------------------------------|-----------------------------------------|--------------------------|
| Concept Option # | Title | Strategy | Estimated Yield (Normal Year) | Capital Cost (\$M)⁽¹⁾ | Unit Cost (\$/AF) |
| 7 | Upper Los Angeles River to DCTWRP | LA River Storage and Use | 5,600 AFY (5 mgd) | \$18 | \$160 |
| 9 | DCTWRP to San Fernando Basin Injection Wells | Potable Reuse with Groundwater Augmentation | 15,000 AFY (14 mgd) | \$360 | \$1,600 |
| 15 | DCTWRP to Los Angeles Aqueduct Filtration Plant | Potable Reuse with Raw Water Augmentation | 15,000 AFY (14 mgd) | \$310 | \$1,500 |
| 16 | DCTWRP to LADWP Distribution System | Potable Reuse with Treated Water Augmentation | 15,000 AFY (14 mgd) | \$295 | \$1,300 |
| 22 | East-West Valley Interceptor Sewer | Flow Management | 12,800 AFY (11.41 mgd) | \$85 | \$430 |
| 26 | Japanese Garden & Sepulveda Basin Lakes Recirculation | Flow Management | 20,000 AFY (18 mgd) | \$20 | \$70 |
| <p><u>Note:</u></p> <p>(1) Total Concept Option cost includes a variety of project components including treatment facilities, conveyance, and injection and extraction facilities. Not all costs pertain to the Wastewater Facilities Plan.</p> <p>(2) Bold indicates a Priority A Concept Option</p> | | | | | |

Donald C. Tillman Water Reclamation Plant

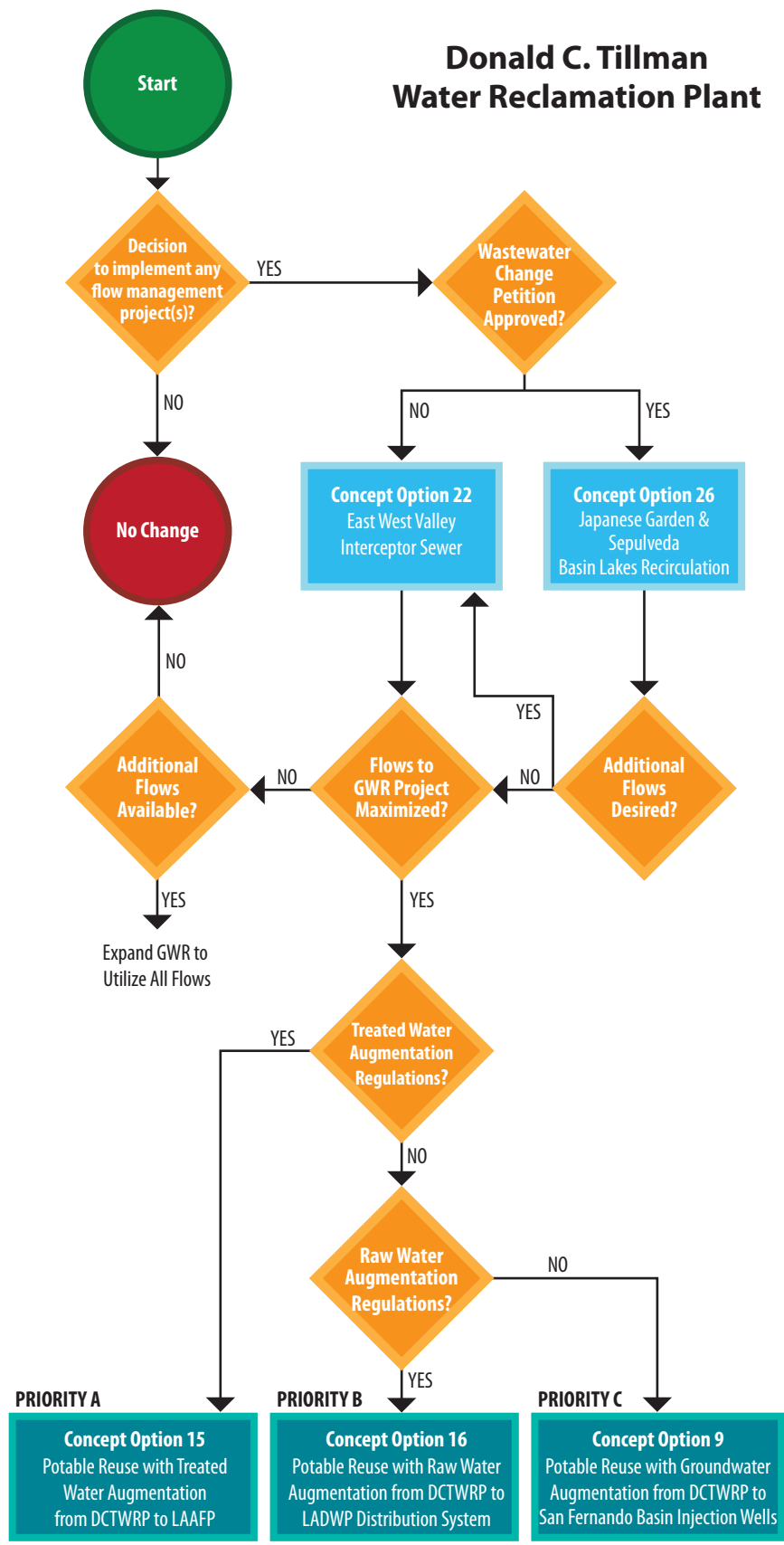

LEGEND & ACRONYMS

- ◆ Trigger
- Concept Option
- Flow Management Option

DCTWRP Donald C. Tillman Water Reclamation Plant
 GWR Groundwater Replenishment Project
 HWRP Hyperion Water Reclamation Plant
 LAGWRP LA-Glendale Water Reclamation Plant
 RWQCB Regional Water Quality Control Board
 TIWRP Terminal Island Water Reclamation Plant
 WRD Water Replenishment District of Southern California

Disclaimer: At each trigger (decision point), evaluate all triggers and concept option priorities to consider changed circumstances in the future.

Figure ES.14
Trigger-Based Implementation Strategy for DCTWRP
 One Water LA 2040 Plan
 Summary Report

The total capacity of the water reuse options from DCTWRP may be constrained by total flow availability and capacity of the plant. As shown on Figure ES.15, the estimated flow available for water reuse after the consideration of existing projects is approximately 20 mgd. This is substantially less than the average flow of 53 mgd listed in Table ES.1 because flows are already allocated to uses identified in Table ES.9.

| Table ES.9 DCTWRP Flow Assumptions Wastewater Facilities Plan One Water LA 2040 Plan | |
|----------------------------------------------------------------------------------------------------------------------------------------------------------------------------------------------------------------------------------|------------------------------|
| Flow Component | Flow (mgd) |
| DCTWRP 2040 Project Influent Flow | 53 |
| Existing Non Potable Reuse | -2 |
| Additional Non Potable Reuse | -2 |
| In-Plant Uses and Lakes ⁽¹⁾ | -26.6 ⁽³⁾ to -8.6 |
| Waste flow to HWRP | -2 |
| Range of Available Flows for Water Reuse (without GWR) | 20-38 |
| GWR Phase 1 ⁽²⁾ | -27 |
| Brine Loss from Advanced Water Purification Facility ⁽²⁾ | -9 |
| Range of Additional Flow Diversion Needed (with GWR) | 0-16 |
| Note: | |
| (1) This value could be reduced from 26.6 mgd to as low as 8.6 mgd through implementation of Concept Option #26 (Japanese Garden & Sepulveda Basin Lakes Recirculation). | |
| (2) Implementation of the GWR AWPf may require the diversion of additional flow to DCTWRP. For this reason, the flow allocated for these items (total of 36 mgd) has not been deducted from the available flows for water reuse. | |
| (3) This is the average flow from July 2014 to June 2015. Flows range from 10.8 mgd to 32.3 mgd during the same period. | |

For planning purposes it was assumed that approximately 14 mgd could be diverted to DCTWRP and therefore 14 mgd (15,000 AFY) was estimated to be the remaining flow available at DCTWRP for reuse. This value was used for the sizing of facilities and equipment that may be needed for each concept option. However, the concept options are preliminary in nature as the projects remain at a high level of definition. Further evaluation would be required should a concept option be implemented.

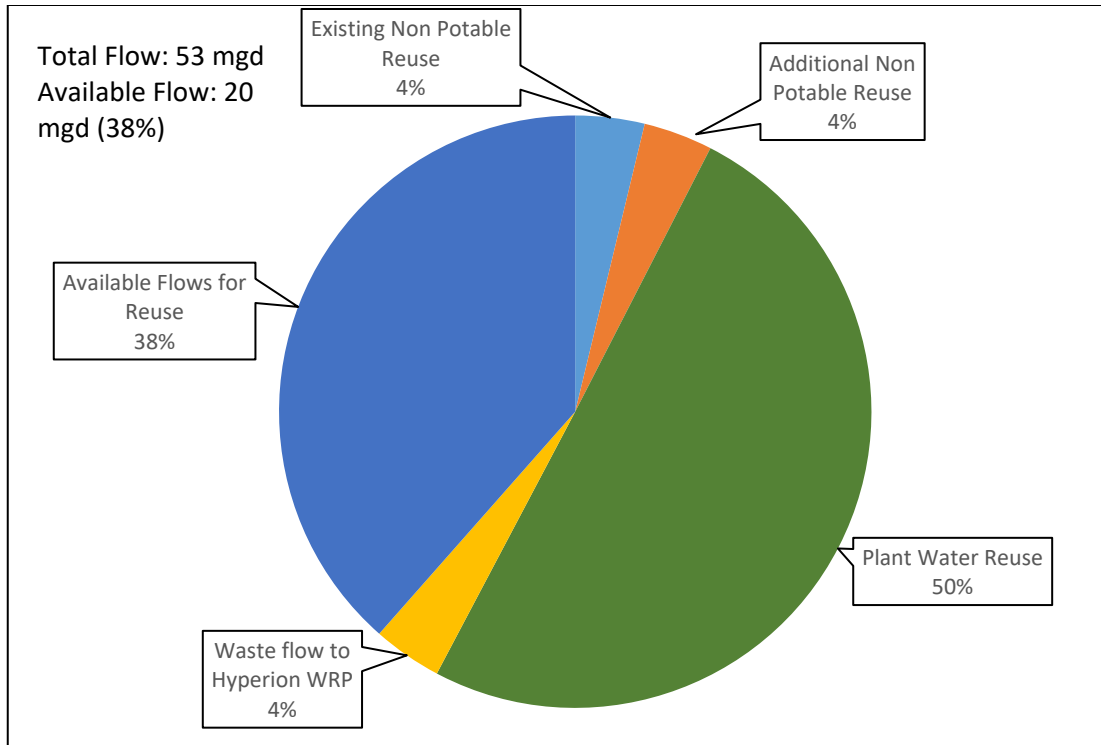

Figure ES.15 Estimated Flow Availability for Water Reuse from DCTWRP (2040 Projection)

Implementation of either concept option may require upgrades to either the plant or the system. Implementation of the EWVIS could require additional lift stations, diversion structures, and multiple pipelines. Conveyance of flows would require 6 miles of force main pipelines, varying in diameter from 24-inch to 42-inch. A total of 6 diversion structures would be needed, in addition to the 6 new lift stations to convey flows to DCTWRP. This concept option would likely not require any immediate changes within DCTWRP. An overall concept flow schematic is shown on Figure ES.16.

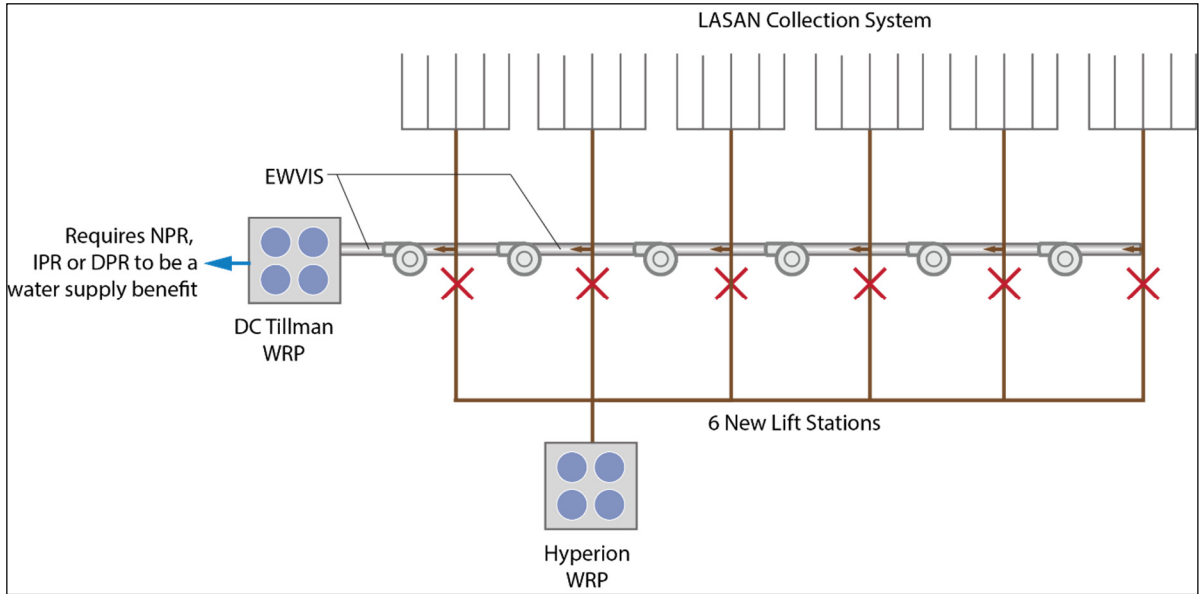

Figure ES.16 Process Flow Schematic Concept Option #22 (East-West Valley Interceptor Sewer)

The implementation of Concept Option #15 (DCTWRP to LA Aqueduct Filtration Plant) may require an additional 14 mgd of AWPf (beyond the GWR project), and 2 MG tertiary equalization tank. To connect to the LADWP distribution system one 2,500 horsepower pump and 8 miles of 36-inch diameter pipe may be needed. An overall flow schematic of this concept option is shown on Figure ES.17. The potential areas for expansion at DCTWRP are shown on Figure ES.18. Figure ES.18 also shows the potential AWPf expansion location in addition to the planned expansion areas in accordance with the US Army Corps of Engineers (USACE) lease.

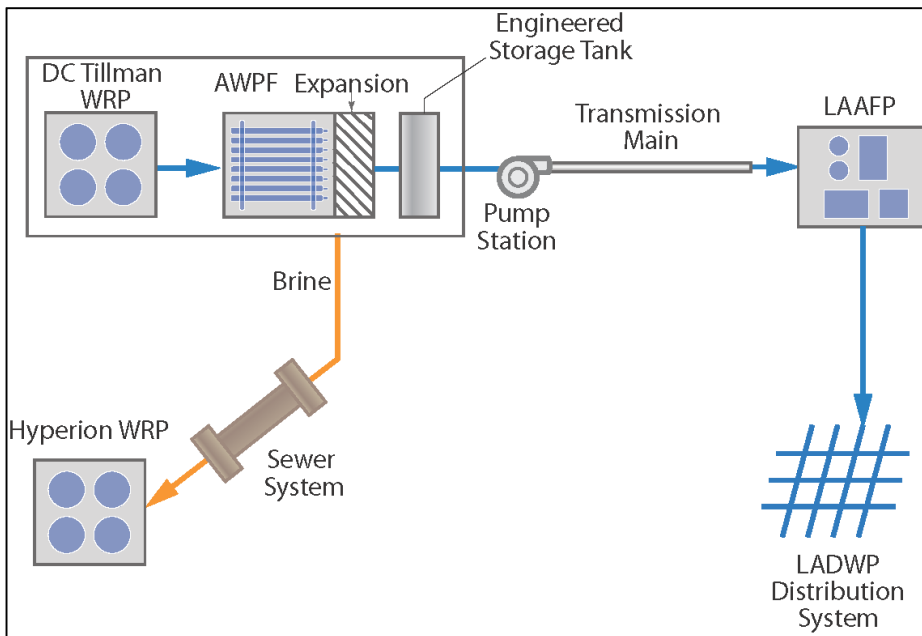
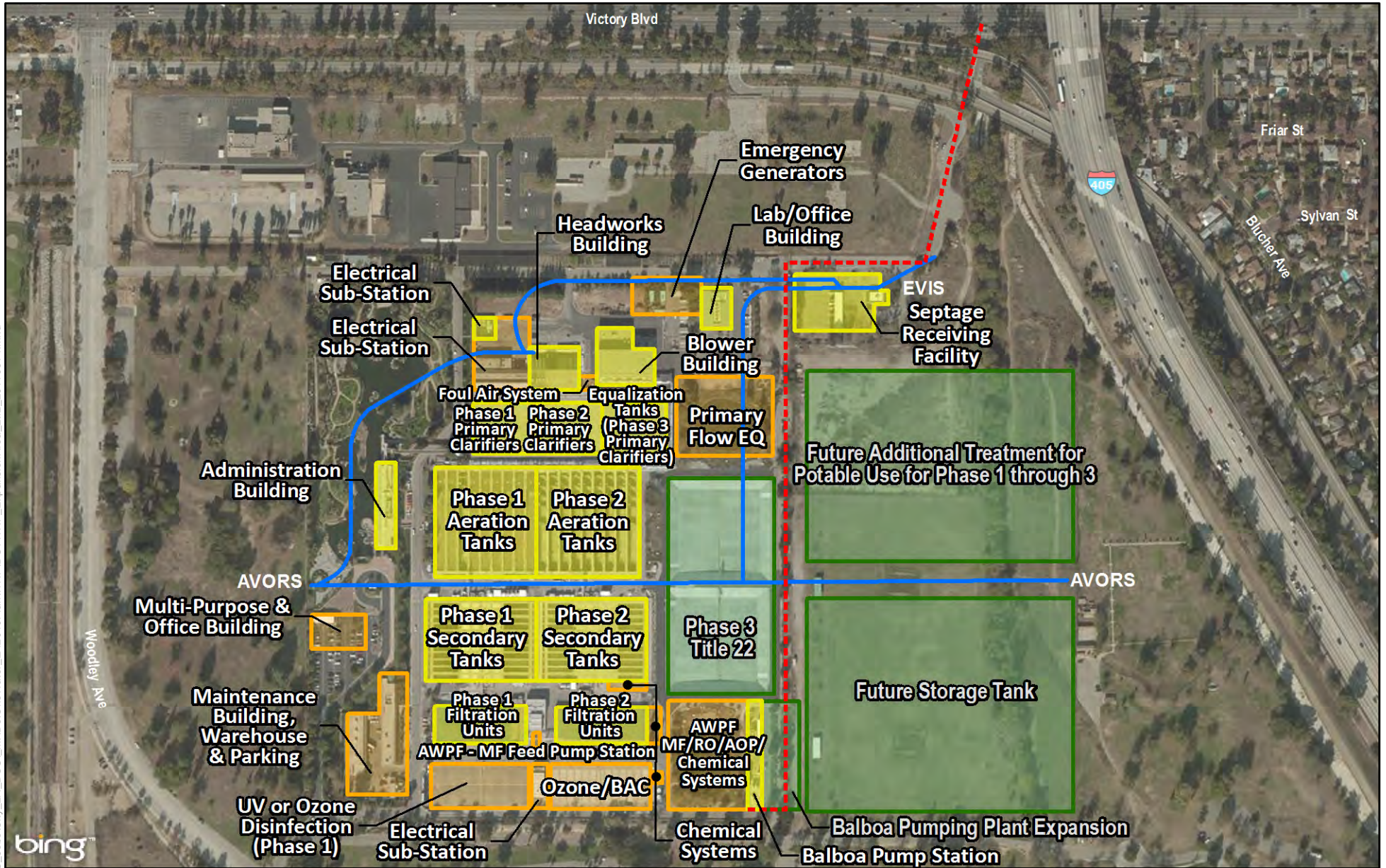

Figure ES.17 Process Flow Schematic for Concept Option #15 (DCTWRP to LAAFP)

Document Path: \\usnr\1s07\GIS\Jobs\City_LA_BOS\MXD\OneWater_LA2040Plan\WRP\DCTWRP_ExpansionArea_LtrL_20170914.mxd



- - - Proposed Brine Line
- AVORS and EVIS
- Existing Facility
- Year 2025 Facility
- Long Term Expansion

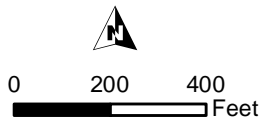

Figure ES.18
Potential Expansion Areas
for Concept Option #15
(DCTWRP to LAAFP)
 One Water LA 2040 Plan

The key benefits associated with Concept Option #15 (DCTWRP to LA Aqueduct Filtration Plant) and Concept Option #22 (East West Valley Interceptor Sewer) are summarized below.

Concept Option #15:

- Expands use of potable reuse with raw water augmentation
- Increases DCTWRP's water reuse flows

Concept Option #22:

- Maximizes City water reclamation plants' available treatment, recycling, and potable reuse capacity (i.e. direct water where it is needed) by redirecting wastewater from one sewershed to another.

Moreover, both of these concept options help fulfill the following One Water key objectives and guiding principles:

- Implement, monitor, and maintain a reliable wastewater system
- Improve local water supplies and reliability
- Integrate management of water resources and policies
- Increase climate resilience

The WRP portion of the costs associated with the implementation of Concept Option #15 (DCTWRP to LA Aqueduct Filtration Plant) and Concept Option #22 (East West Valley Interceptor Sewer) are included in the WWFP Adaptive CIP. The WWFP Adaptive CIP is discussed in further detail in Section ES.8. Details of the other concept options are discussed in Appendix D.

ES.5.3 LAGWRP

Two concept options were identified and evaluated for the LAGWRP as part of the future strategies previously described. These concept options, shown in Table ES.10 were prioritized and the preferred concept option (Priority A) was identified as Concept Option #17 (LAGWRP to Headworks Reservoir). The most critical trigger, as shown on Figure ES.19, for this concept option is adopting potable reuse with treated water augmentation regulations that would allow this type of water reuse practice.

If the potable regulations are not accepted within a desired timeframe, or if the City prefers a more conventional form of water reuse, the Priority B Concept Option #23 (NPR expansion beyond 2015 UWMP) could be considered for the remaining available flows. The most critical trigger for this option is new customer demand that is cost-effective to serve, considering the customer's location, demand size, demand variability, and water quality requirements.

| Table ES.10 LAGWRP Concept Options Wastewater Facilities Plan One Water LA 2040 Plan | | | | | |
|-----------------------------------------------------------------------------------------------------|-------------------------------------------------|------------------------------------------------------|--------------------------------------|-----------------------------------------|--------------------------|
| Concept Option # | Title | Strategy | Estimated Yield (Normal Year) | Capital Cost (\$M)⁽¹⁾ | Unit Cost (\$/AF) |
| 17 | LAGWRP to Headworks Reservoir | Potable Reuse with Treated Water Augmentation | 6,000 AFY (5 mgd) | \$140 | \$1,500 |
| 23 | Increase Recycled Water Demand beyond 2015 UWMP | Non-Potable Reuse | 3,500 AFY (3 mgd) | \$70 ⁽²⁾ | \$2,100 |

Note:

(1) Total Concept Option cost includes a variety of project components including treatment facilities, conveyance, and injection and extraction facilities. Not all costs pertain to the Wastewater Facilities Plan.

(2) This capital cost reflects the proportion of costs specifically for LAGWRP to implement Concept Option #23 (Increase Recycled Water Demand beyond 2015 UWMP). The cost was calculated using proportions of yield and cost relative to overall concept implementation cost.

(3) Bold indicates a Priority A Concept Option

LA-Glendale Water Reclamation Plant

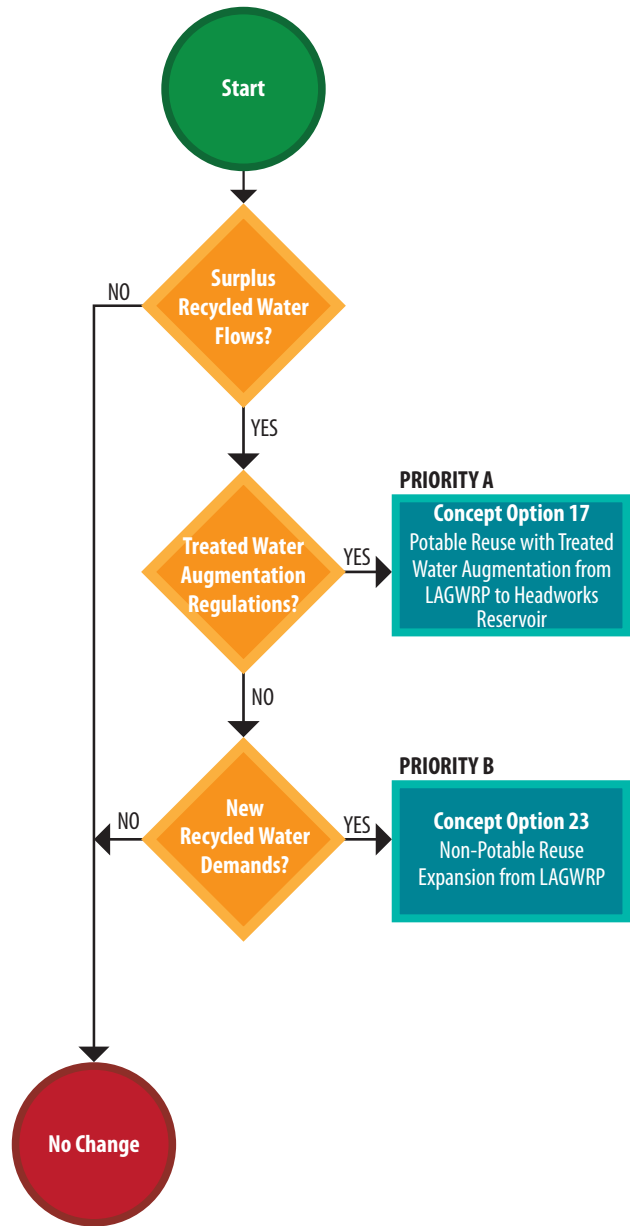

LEGEND & ACRONYMS

- ◆ Trigger
- Concept Option
- Flow Management Option

| | |
|--------|-----------------------------------------------------|
| DCTWRP | Donald C. Tillman Water Reclamation Plant |
| GWR | Groundwater Replenishment Project |
| HWRP | Hyperion Water Reclamation Plant |
| LAGWRP | LA-Glendale Water Reclamation Plant |
| RWQCB | Regional Water Quality Control Board |
| TIWRP | Terminal Island Water Reclamation Plant |
| WRD | Water Replenishment District of Southern California |

Disclaimer: At each trigger (decision point), evaluate all triggers and concept option priorities to consider changed circumstances in the future.

Figure ES.19
Trigger-Based Implementation Strategy for LAGWRP
One Water LA 2040 Plan
Summary Report

The concept options consist of various potable reuse options. The estimated yield associated with the potable reuse options are dependent on the quantity of LAGWRP flows available for water reuse. The estimated available flow for additional water reuse is limited to roughly 5 mgd or 6,000 AFY. This is due to the flows that are already allocated to the uses identified in Table ES.11 and Figure ES.20.

| Table ES.11 LAGWRP Flow Assumptions Wastewater Facilities Plan One Water LA 2040 Plan | |
|------------------------------------------------------------------------------------------------------|-----------------------|
| Flow Component | Flow (mgd) |
| LAGWRP 2040 Project Influent Flow | 22 |
| City of Glendale ⁽¹⁾ | -11 |
| In-Plant Uses | -0.8 |
| NPR Demands | -4 |
| Waste Discharge and Bypass to HWRP | -0.5 |
| Range of Available Flows for Water Reuse | 0-5.7 |
| <u>Note:</u> | |
| (1) City of Glendale co-owns LAGWRP, Glendale is entitled to 50% of the flows | |

A conservative estimate of 5 mgd was used to account for the remaining flows available at LAGWRP for water reuse. This flow may vary due conservation, and the amount of flow bypassed to HWRP. This value was used for the sizing of facilities and equipment may be needed for each concept option as discussed in greater detail in Chapter 6 of the WWFP.

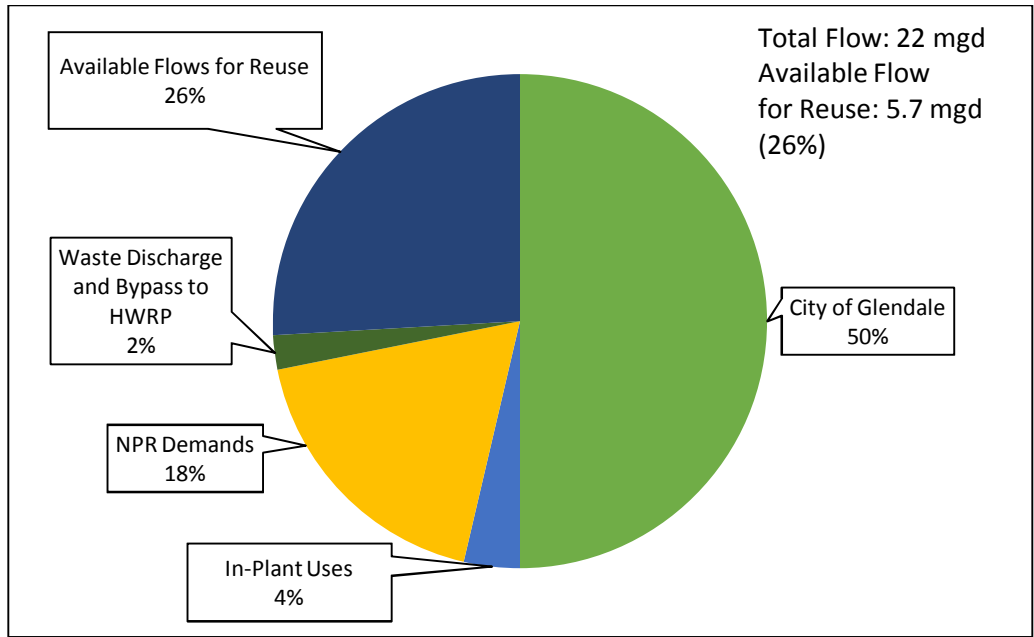

Figure ES.20 Estimated Flow Availability for Water Reuse from LAGWRP (2040 Projection)

The implementation of Concept Option #17 (LAGWRP to Headworks Reservoir), assumes a 5 mgd AWPf would treat the recycled water to achieve potable reuse with treated water augmentation requirements at the time of project implementation. These processes have been assumed to consist of ozone/biologically active filters (O₃/BAF), ultrafiltration (UF), RO, and UV/AOP. A 1 MG engineered storage tank would also be required to provide 3 hours of detention time. Brine disposal is assumed to utilize the existing sewers to HWRP. Per discussions with City staff, a potential alternative location for the AWPf could be adjacent to the Headworks Reservoir. The feasibility of this alternative location could be evaluated in the future.

A new 200 horsepower pump station would also be constructed to convey the product water to the Headworks Reservoir. Pipeline would be 4 miles and 24 inches in diameter. Figure ES.21 shows an overall concept schematic with the aforementioned components may be needed for implementation.

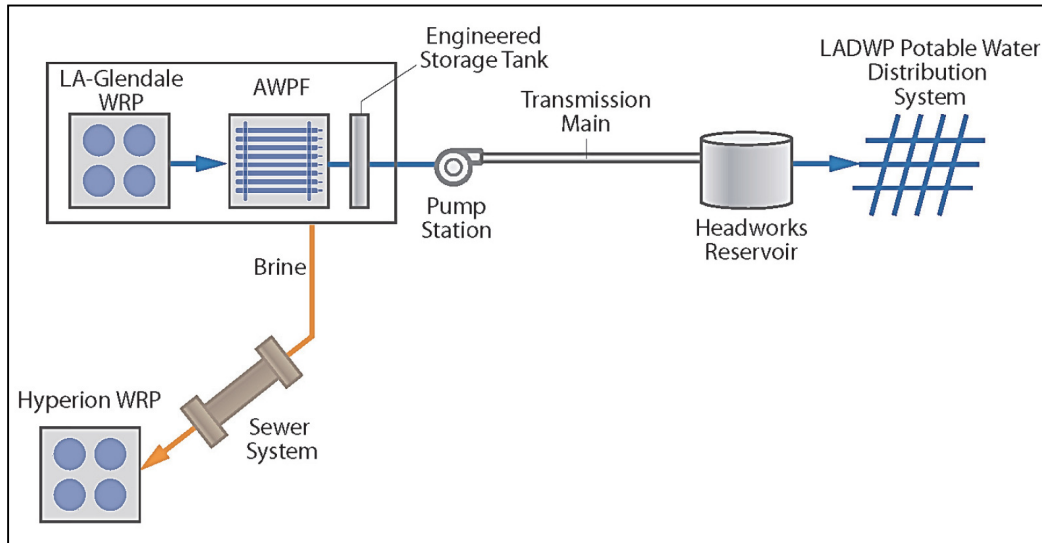

Figure ES.21 Process Flow Schematic Concept Option #17 (LAGWRP to Headworks Reservoir)

Potential locations of the AWPf, storage tank and pump station are shown on Figure ES.22 however the final location of these upgrades would be determined during detailed design should this concept option be selected for implementation.

The key benefits associated with this concept option consist of:

- Expands LAGWRP’s treatment technology and increases flows available for water reuse
- Expands use of potable reuse with treated water augmentation

Moreover, this concept option helps fulfill the following One Water key objectives and guiding principles:

- Implement, monitor, and maintain a reliable wastewater system
- Improve local water supplies reliability
- Integrate management of water resources and policies
- Increase climate resilience

The WRP portion of the cost associated with the implementation of Concept Option #17 (LAGWRP to Headworks Reservoir) is included in the WWFP Adaptive CIP. The WWFP Adaptive CIP is discussed in further detail in Section ES.8. Details of the other concept options are discussed in Appendix E.



- Upcoming Project
- Potential AWWPF Location

Figure ES.22
Potential Process Location for Concept
Option #17
(LAGWRP to Headworks Reservoir)
 One Water LA 2040 Plan

ES.5.4 TIWRP

Currently the majority of the plant flow is treated and reused. Additionally, future projected tributary flow increases are limited. Due to these considerations, the estimated available flow for additional water reuse is constrained. As a result, no concept options were identified for TIWRP. A breakdown of the allocated flows and potential remaining flows available for reuse are detailed in Table ES.12 and Figure ES.23.

| Table ES.12 TIWRP Flow Assumptions Wastewater Facilities Plan One Water LA 2040 Plan | |
|-----------------------------------------------------------------------------------------------------|-------------------|
| Flow Component | Flow (mgd) |
| TIWRP 2040 Project Influent Flow | 18 |
| Brine Loss due to AWPf | -3.6 |
| Dominguez Gap Barrier | -7.5 |
| Machado Lake | -0.2 |
| Harbor Other Users | -0.5 |
| Industrial Users and Future Users | -2.5 up to -3.5 |
| Range of Available Flows for Water Reuse | 2.7 to 3.7 |

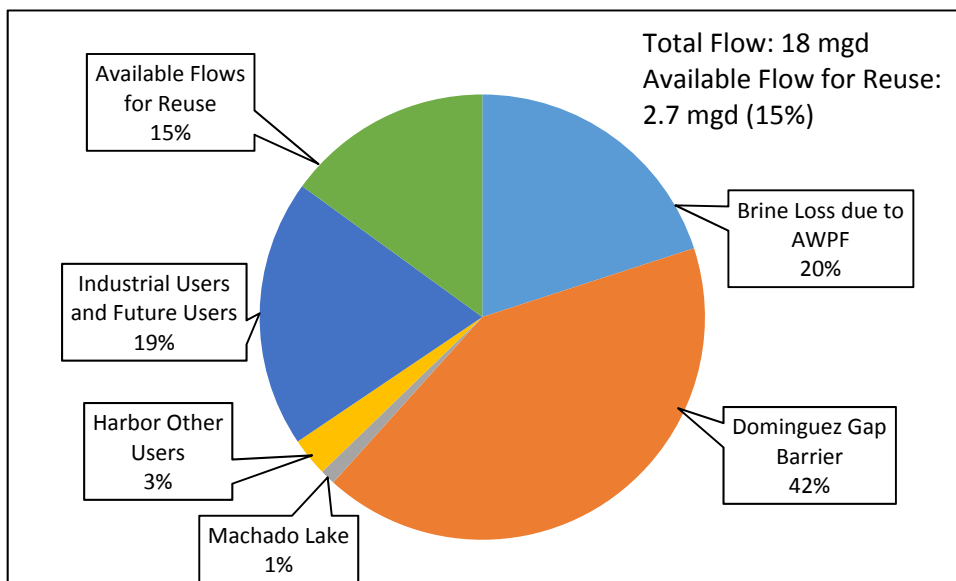

Figure ES.23 Estimated Flow Availability for Water Reuse from TIWRP (2040 Projection)

ES.5.5 Potential Future Water Reclamation Plant Options

In addition to the four existing WRPs, the opportunities and benefits to construct one or more new WRPs was evaluated as part of the Plan. Based on the analysis, it was concluded that the most beneficial location to potentially add a new WRP is to construct a new facility near Rancho Park in West LA. This project was also identified as one of the top, current integration opportunities.

Although this project concept is still under development, the current conceptual project components of the Rancho Park Water Reclamation Facility project include:

- Component 1 – Stormwater capture and treatment system to supplement irrigation demands at the Rancho Park Golf Course and Cheviot Hills Recreation Center.
- Component 2 – Satellite WRP to meet non-potable demands in the regional service area, including potential recycled water delivery to the UCLA campus.
- Component 3 – Expansion of satellite WRP to meet peak seasonal non-potable demands in the regional service area.

The Rancho Park Water Reclamation Facility project would produce recycled water. The recycled water would be augmented with dry weather runoff and stormwater, when available, to serve non-potable water demands near Rancho Park (West LA). LASAN would lead the project, while LADWP and Los Angeles Department of Recreation and Parks (RAP) would be supporting agencies. This integrated approach would be a multi-benefit project that:

1. Produces recycled water to meet substantial non-potable demands in the Westside area, including industrial uses and irrigation for the UCLA campus, the City's largest municipal golf course, and several other users.
2. Captures stormwater to retain, treat, and remove pollutants such as trash, metals, and bacteria.
3. Increases reliability of supply by being locally sourced and climate resilient.

Successful implementation of this project requires thoughtful, proactive communication both within City government and with the surrounding community.

ES.5.6 On-Site Treatment

On-site treatment facilities (OSTFs) are small facilities at point-of-use locations. OSTFs would be located upstream of one of the City's water reclamation plants to serve specific non-potable water demands or potentially for localized groundwater replenishment. OSTFs could be owned by the City or private entities and may or may not include solids treatment. LASAN does not currently have a policy that regulates or prevents other entities from performing on-site treatment.

Additional OSTFs could be implemented throughout the City service area and serve the local needs of smaller areas. Demands for this water could come from industries who may have recycled water uses. However, complete bypass around the OSTF and back-up potable water supplies would be required to ensure failsafe disposal during process upsets or facility maintenance. New on-site treatment facilities could potentially have financial impacts due to declining revenues, as well as consequences for treatment and conveyance due to changes in wastewater quality, such as biological oxygen demand (BOD) and total suspended solids (TSS) concentrations. This analysis is included in TM 12.5.1, 12.5.2 and 12.5.3 – Task 12 Special Studies On-Site Treatment (see Volume 8).

In addition to the wastewater projects in the WCIP and the recommended concept options, the One Water LA policies outline strategies for developing guidelines for Onsite Treatment Facilities (OSTFs). Two of the recommended policies for these OSTFs include (1) developing guidelines that protect public health and outline operations of wastewater and recycled water systems (#38), and (2) providing a fee structure and payment guidelines that reflect collection and treatment system impacts and costs (#39). Stakeholders also recommended expanding education and engagement programs on Potable Reuse (#35). A full list of the policies and action items can be found in Chapter 9 and Appendix F of the Summary Report (Volume 1).

ES.6 BIOSOLIDS MANAGEMENT

Biosolids processing at a treatment plant is integral to the achievement of regulatory compliance for effluent quality, solids diversion/reuse, and air emissions. In recent years, regulatory drivers and public perception have further accentuated the importance of the biosolids processing component of wastewater management to successful system operation. The City is one of the largest wastewater treatment agencies in Southern California and as such the management of biosolids is critical.

Currently, LAGWRP and DCTWRP do not have solids handling facilities, instead both facilities convey solids to the HWRP. HWRP and TIWRP have onsite systems to process biosolids and facilitate their beneficial reuse. TIWRP has changed from land applying Class A biosolids cake at a site in Maricopa County, Arizona to utilizing the TIRE demonstration project for 100 percent of the biosolids produced at TIWRP along with a portion of the biosolids from HWRP. HWRP land applies Class A biosolids to the Green Acres Farm. Both plants meet quality requirements dictated by regulatory standards for the respective approaches to biosolids reuse/diversion.

Potential changes in biosolids management need to be further studied and reviewed in the development of any long term plan to assist the City in developing a diverse portfolio of effective options in both the near term and long term. This diverse portfolio would incorporate flexibility to adjust to future changing conditions.

ES.7 CLIMATE RISK ASSESSMENT FOR WASTEWATER INFRASTRUCTURE

Climate change will likely increase annual average temperatures, precipitation patterns, extreme rain events and sea level rise. These trends could result in damages at wastewater treatment plants and/or conveyance facilities. To proactively manage these risks, a climate change risk assessment was performed for each of the WRPs, consisting of scenario development, screening analysis, site visits, risk analyses, and adaptation planning alongside LASAN staff. The assessment performed also included use of the US EPA's Climate Resilience Evaluation and Awareness Tool (CREAT) to identify potential climate change scenarios and risk assessment. Climate risk and resilience analysis requires additional assessment and modifications to planning, design, and construction of infrastructure. Site visits and inspections of the WRPs and below-ground pumping facilities were used to assess climate change risks and vulnerabilities. Hazards identified for WRP assets were:

- 500 year Flood Zone (Elevation:12.25 feet)
- Tsunami (Elevation: approximately 20 feet)
- Sea level rise of 0.5-1.5 meter based on CoSMoS (Elevation: 11.64 – 14.92 feet)

Based on the hazards identified Damage Threshold Elevations were also identified:

- Door Elevation: 11.17 feet
- Generator Pad Elevation: 11.89 feet

These elevations were used to determine the WRP assets that were at risk. Subsequently, practical improvements were identified to mitigate these risks, such as:

- Install watertight connections
- Waterproof instrumentation and controls
- Add backup power generation
- Construct floodwalls and flood gates
- Raise mechanical and electrical equipment to avoid flooding

The identified climate resilience improvements were included in the CIP of each WRP as presented in Section ES.8. A more detailed description of the climate risk assessment of wastewater infrastructure is included in the Chapter 10 of this Volume, while a similar analysis of stormwater infrastructure is included in the Stormwater and Urban Runoff Facilities Plan (see Volume 3). The complete analysis is included in the Climate Risk and Resilience Assessment for Wastewater and Stormwater Infrastructure (see Volume 6).

ES.8 WASTEWATER FACILITIES ADAPTIVE CAPITAL IMPROVEMENT PLAN

The WWFP Adaptive CIP combines the identified capital improvement projects for both the wastewater collection system and the four WRPs, as well as In-Progress Projects and concept options to create a comprehensive CIP. The purpose of this WWFP Adaptive CIP is to help guide the City with prioritization, decision making, and implementation of projects that align with the City's long-term vision.

ES.8.1 Cost Estimating Assumptions

Four primary sources of information and costing were integrated to develop the WWFP Adaptive CIP. These sources are:

1. Los Angeles Bureau of Engineering (LABOE) Uniform Project Reporting System (UPRS) – The UPRS is the publicly available source for project documented in the WCIP and other sources. The UPRS was used in conjunction with the WCIP to cross reference project for inclusion in the WWFP Adaptive CIP.
2. LASAN Wastewater Capital Improvement Plan (WCIP) - The WCIP includes capital developed for the City's Clean Water facilities. The projects included in this document have been approved by the City's Program Review Committee, comprised of Assistant Directors of LASAN and a Deputy City Engineer. The administration, coordination, and implementation of the projects in the 10-Year (FY 2015/16-2024/25) WCIP are assigned to various divisions of LASAN and BOE in the Department of Public Works. The Program includes replacement, rehabilitation, and expansion of the City's wastewater treatment and collection system facilities.
3. Los Angeles Department of Water and Power (LADWP) 2015 UWMP - Every five years LADWP develops a new UWMP that documents the City's efforts since the previous document, updates goals for the next 25 years, and identifies changes since the previous document.
4. Future Integration Opportunities - These opportunities (also referred to as concept options) were developed as part of the Plan and are described in Chapter 6.

The capital costs for the concept options were developed using assumed treatment components of the WRPs and assumed unit costs. These costs are based on industry standards and include construction contingencies. Land acquisition costs are not included and all costs have a 2.0 multiplier as these projects are preliminary in nature. All costs are reported in 2017 dollars.

After the compilation of the data, the CIP was reviewed. In areas where no or a low estimate was reported, implying little or no planned costs, further analysis was undertaken.

Methodologies were employed to provide projections for future costs. Details of these methodologies are described in Chapter 11.

In addition to the above sources, discussions were held with Plant Managers and their staff regarding their views and recommendations for their respective water reclamation plant CIP.

ES.8.2 CIP Planning Phases and Project Categories

The WWFP Adaptive CIP is separated into the following three distinct planning phases:

- **Near-term:** This planning phase includes projects that are planned for the 3-year period from 2018 to 2020.
- **Mid-term:** This planning phase includes projects that are planned for the 10-year period from 2021 to 2030.
- **Long-term:** This planning phase includes projects that are planned for the 10-year period from 2031 to 2040.

In addition to the 3 planning phases, the CIP is also organized by the following five project categories:

- **Capital Projects from WCIP** – These projects were previously identified in the WCIP. These projects include new construction, expansion, or renovation that helps maintain or improve a City facility or infrastructure that may be funded by the Capital Budget.
- **Replacement and rehabilitation Projects from WCIP** – These projects were previously identified in the WCIP. These projects are required for the continued operation of the facility in its present form.
- **Climate Resiliency Projects** – These are projects developed as part of the Plan and identified in Volume 6 Climate Risk and Resilience Assessment for Wastewater and Stormwater Infrastructure. These projects are needed to adapt to environmental conditions due to climate change
- **Projected Capital Projects** – These are projects not identified in the WCIP and are projected as part of the WWFP in collaboration from City staff. These projects include new construction, expansion, or renovation that helps maintain or improve a City facility or infrastructure that may be funded by the Capital Budget. Project costs were estimated using a methodology described in Chapter 11.
- **Projected replacement and rehabilitation Projects** – These are projects not identified in the WCIP and are projected as part of the WWFP in collaboration with City staff. These projects may be needed for the continued operation of the facility in its present form. These projects were estimated using the methodology in Chapter 11 of this Volume.

The following subsections present components of the WWFP Adaptive CIP, starting with the In-Progress Projects, followed by the current integration opportunities, future integration opportunities (concept options) and the Estimated and Projected CIP.

ES.8.3 In-Progress Projects

In-Progress Projects are defined as planned supply projects or programs for groundwater, recycled water, and stormwater that are expected to be implemented outside and independent of the Plan. Table ES.13 summarizes the In-Progress Projects, estimated capital costs, projected construction completion and resulting phase. Additional details of the In-Progress Projects can be found in Volume 5.

| Table ES.13 Summary of In Progress Project Estimated Costs Wastewater Facilities Plan One Water LA 2040 Plan | | | |
|------------------------------------------------------------------------------------------------------------------------------------------------------------------------------------------------------------------------------------------------------------------------------|------------------------------------------------------------------|--------------------------|--------------|
| In-Progress Projects | Estimated Capital Cost Estimate (\$2017) Millions | Year Complete | Phase |
| Advanced Treated Recycled Water Delivery to LAX and Scattergood Generating Station | \$38 ⁽¹⁾ | 2019-2020 | Near |
| HWRP Delivery Expansion to 70 mgd for WBMWD and LA Harbor Area | \$16 ⁽²⁾ | 2020 | Near |
| DCTWRP Groundwater Replenishment Project with AWPf | \$370 ⁽³⁾ | 2023 | Near/Mid |
| LAGWRP Increase Recycled Water Demand beyond 2015 UWMP | \$73 | 2018-2020 | Near |
| TIWRP AWPf Expansion to 12 mgd (Completed in 2017) | \$n/a ⁽⁴⁾ | Mid-2017 | Near |
| Total | \$497 | | |
| Note: | | | |
| (1) Cost of phase 1 of this project is estimated at \$38 million, scheduled to occur in the near-term. Expansion of additional 3.5 mgd (product water) could occur in the mid-term, for an estimated capital cost of \$92 million for a total capital cost of \$130 million. | | | |
| (2) The estimated capital cost is for the expansion of the pump station and does not include WBMWD's costs. An additional cost of \$400 million could be incurred in the future should 70 mgd of MBR treatment be installed at HWRP. | | | |
| (3) Groundwater Replenishment Project with AWPf identified by a WCIP. Phasing will be split into near term and mid-term. | | | |
| (4) TIWRP Expansion to 12 mgd was completed during the finalization of the WWFP. For this reason, it has not been included in the total cost of the In-Progress Projects. | | | |

The City is demonstrating a commitment to focus significant resources on alternative water supply sources through the implementation of In-Progress projects such as the

Groundwater Replenishment Project with AWPf at DCTWRP and the Advanced Treated Recycled Water Delivery to LAX and Scattergood Generating Station.

ES.8.4 Current Integration Opportunities

Another component of the WWFP Adaptive CIP are the current integration opportunities, such as future WRPs. New water reclamation plants are being considered to provide satellite treatment in communities with limited access to reclaimed water and a proven cost effective demand for its use. One option for a new plant is in the Rancho Park area, which would provide a stormwater capture and treatment system along with one or more satellite WRP(s) to meet non-potable demands in the regional service area. The estimated project cost is approximately \$58 million, which does not include the cost of the recycled water conveyance system.

City staff has continued the feasibility evaluation of this project and discussions between LASAN, LADWP, and the department of Recreation and Parks (RAP) are ongoing. This project provides the following benefits:

- Produces recycled water to meet substantial non-potable demands in the Westside area, including industrial uses and irrigation for the UCLA campus, the City's largest municipal golf course, and several other users.
- Captures stormwater to retain, treat, and remove pollutants such as trash, metals, and bacteria
- Increases reliability of supply by being locally sourced and climate resilient

Although the project configuration is still subject to change, there is no new report or cost estimate for this project at the time of this plan development. Hence, the cost estimate of \$58 million will be used in the WWFP Adaptive CIP.

ES.8.5 Future Integration Opportunities

The future integration opportunities analysis yielded the concept options discussed in Section ES.5. These concept options are another component of the WWFP Adaptive CIP. A more detailed discussion of the concept option scoring, and portfolio evaluation results can be found in Chapter 6 (see Volume 1). Table ES.14 summarizes the concept options, priority, and the associated costs per WRP.

| Table ES.14 Summary of Concept Option Portfolios Wastewater Facilities Plan One Water LA 2040 Plan | | | | | |
|-------------------------------------------------------------------------------------------------------------------|-----------------|----------|-------------------------------------------------|-------------------------------------------------------------------|-----------------------------------|
| WRP | Priority | # | Concept Option Name | Total Future Integration Opportunities Cost Estimate (\$M) | WWFP Portion of Cost (\$M) |
| HWRP | A | 13 | MBR at HWRP to Regional System | \$900 | \$900 |
| | B | 18 | Hyperion to LADWP Distribution System | \$2,800 | \$2,500 |
| | C-1 | 11 | HWRP to Central Basin Injection Wells | \$3,300 | \$1,700 |
| | C-2 | 10 | HWRP to West Coast Basin Injection Wells | \$900 | \$450 |
| DCTWRP | A | 15 | DCTWRP to LA Aqueduct Filtration Plant | \$310 | \$220 |
| | A | 22 | East-West Valley Interceptor Sewer | \$85 | \$85 |
| | B | 16 | DCTWRP to LADWP Distribution System | \$295 | \$260 |
| | C | 9 | DCTWRP to San Fernando Basin Injection Wells | \$360 | \$200 |
| LAGWRP | A | 17 | LAGWRP to Headworks Reservoir | \$140 | \$120 |
| | B | 23 | Increase Recycled Water Demand beyond 2015 UWMP | \$70 | \$0 |

As noted in the discussion of the concept options, the implementation may require upgrades to the WRP and the surrounding system. Only the portion of the WRP cost was carried forward into the WWFP Adaptive CIP.

ES.8.6 Estimated and Projected CIP Summary

Information from the WCIP is collated and presented by facility (each of the WRPs and the collection system), phase (near-term, mid-term and long-term), and category (replacement and rehabilitation, climate resiliency and capital project). After the compilation of the Estimated CIP, the distribution of costs was reviewed. In areas where no or low estimates were available, costs were projected utilizing the methods summarized in Chapter 11 of this

Volume. As the City defines more projects, the Projected CIP should be updated to reflect the most current numbers for the near, mid, and long terms. Projects for each CIP are summarized in Appendix H.

ES.8.7 WWFP Adaptive CIP

The combination of the In-Progress Projects, Estimated and Projected CIP, long-term concept options and current integration opportunity form the basis for the WWFP Adaptive CIP. The Adaptive CIP is summarized in 2017 dollars in Table ES.15.

| Table ES.15 WWFP Adaptive CIP Summary 2017 (\$M) | | | | |
|------------------------------------------------------------------------------------|--------------------------------------------|-------------------------------------------|--------------------------------------------|------------------------|
| Wastewater Facilities Plan | | | | |
| One Water LA 2040 Plan | | | | |
| Category | Near-term (2018-2020) (\$M) | Mid-term (2021-2030) (\$M) | Long-term (2031-2040) (\$M) | Total (\$M) |
| In Progress Projects | | | | |
| Advanced Treated Recycled Water Delivery to LAX and Scattergood Generating Station | \$38 ⁽¹⁾ | \$92 | | \$130 |
| HWRP Delivery Expansion to 70 mgd for WBMWD and LA Harbor Area | \$16 ⁽²⁾ | | | \$16 |
| Groundwater Replenishment Project with AWPf at DCTWRP | \$185 | \$185 | | \$370 |
| LAGWRP Increase Recycle Water Demand per 2015 UWMP | \$73 | | | \$73 |
| TIWRP AWPf Expansion to 12 mgd | n/a ⁽³⁾ | | | n/a ⁽³⁾ |
| Subtotal | \$311 | \$277 | \$0 | \$589 |
| Current Integration Opportunities | | | | |
| Rancho Park WRF | \$58 ⁽⁴⁾ | | | \$58 |
| Subtotal | \$58 | | | \$58 |
| Water Reclamation Plants | | | | |
| Capital Project from WCIP | \$178 | \$71 | \$10 | \$259 |
| Replacement & Rehabilitation from WCIP | \$184 | \$115 | \$12 | \$311 |
| Climate Resiliency Project | \$27 | | \$14 | \$41 |
| Projected Capital Project | | \$59 | \$1,360 | \$1,419 |
| Projected Replacement & Rehabilitation Project | | \$100 | \$518 | \$618 |
| Subtotal | \$389 | \$345 | \$1,914 | \$2,648 |
| Collection System | | | | |
| Collection System | \$641 | \$78 | \$22 | \$741 |
| Subtotal | \$641 | \$78 | \$22 | \$741 |
| Future Integration Opportunities | | | | |

| Table ES.15 WWFP Adaptive CIP Summary 2017 (\$M) | | | | |
|--------------------------------------------------------------------------------------------------------------------------------------------------------------------------------------------------------------------------------------------------------------------------------------------------------------------------------------------------------|--------------------------------------------|-------------------------------------------|--------------------------------------------|------------------------|
| Wastewater Facilities Plan | | | | |
| One Water LA 2040 Plan | | | | |
| Category | Near-term (2018-2020) (\$M) | Mid-term (2021-2030) (\$M) | Long-term (2031-2040) (\$M) | Total (\$M) |
| (WWFP Cost Element) | | | | |
| Concept Option #13 (MBR at HWRP to Regional System) | | | \$900 | \$900 |
| Concept Option #15 (DCTWRP to LA Aqueduct Filtration Plant) | | | \$220 | \$220 |
| Concept Option #17 (LAGWRP to Headworks Reservoir) | | | \$120 | \$120 |
| Concept Option #22 (East-West Valley Interceptor Sewer) | \$85 | | | \$85 |
| | | | | |
| | | | | |
| Subtotal | \$85 | \$0 | \$1,240 | \$1,325 |
| Total | \$1,484 | \$700 | \$3,176 | \$5,360 |
| Notes: | | | | |
| (1) Cost of phase 1 of this project is estimated at \$38 million, scheduled to occur in the near-term. Expansion of additional 3.5 mgd (product water) could occur in the mid-term, for an estimated capital cost of \$92 million for a total capital cost of \$130 million. For conservative cost estimations, the expansion was included in the CIP. | | | | |
| (2) An additional cost of \$400 million could be incurred in the future should 70 mgd of MBR treatment be installed at HWRP. | | | | |
| (3) TIWRP Expansion to 12 mgd was completed during the finalization of the WWFP. For this reason, it has not been included in the total cost of the In-Progress Projects. | | | | |
| (4) Rancho Park WRF project costs are currently being refined. | | | | |

As shown on Figure ES.24, the Adaptive CIP for the near-term totals, \$1,484 million, the mid-term totals \$700 million and the long-term totals \$3,176 million. This is driven by both the future integration opportunities as well as the projected capital and replacement and rehabilitation project estimates.

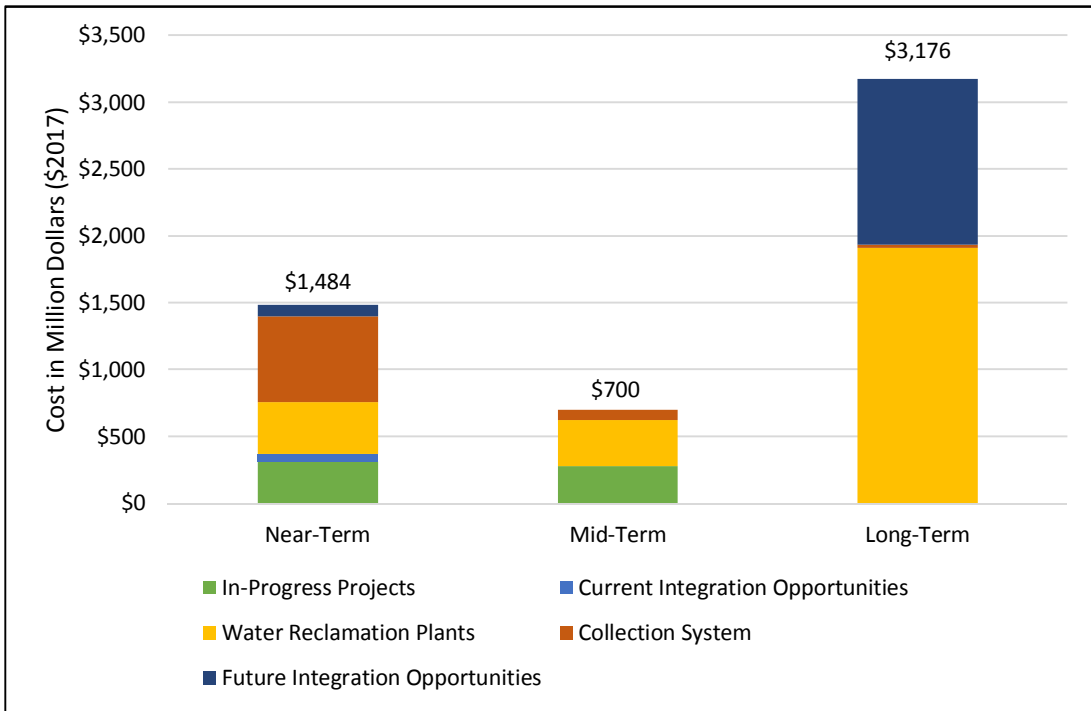

Figure ES.24 WWFP Adaptive CIP Summary by Phase

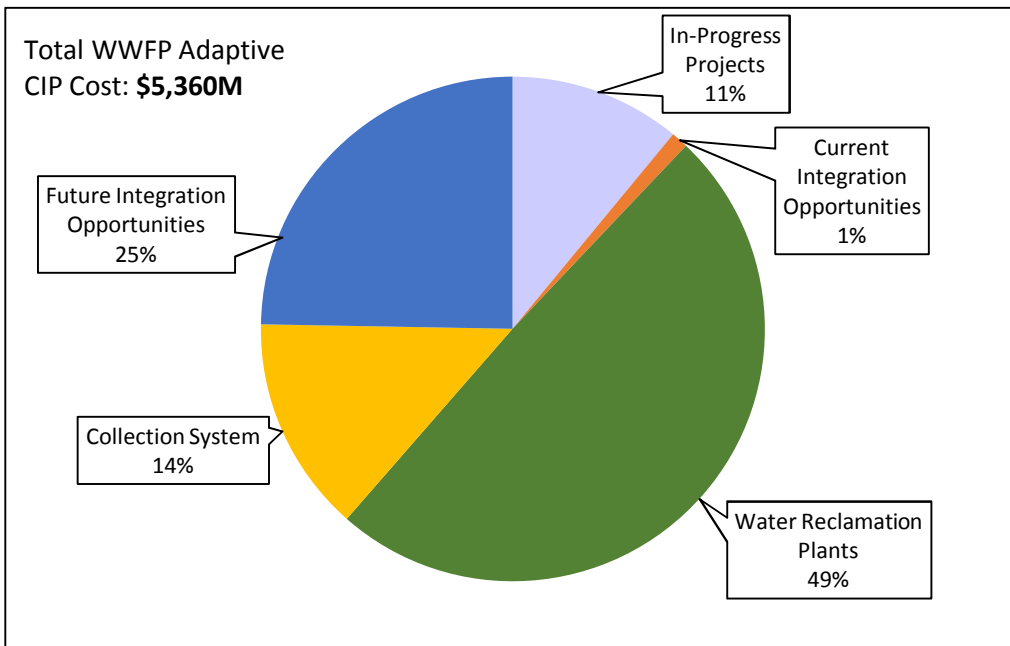

Figure ES.25 WWFP Adaptive CIP by Category

Figure ES.25 shows the largest portion of the total WWFP Adaptive CIP is to be spent on the WRPs.

ES.8.8 Escalated CIP

This section provides the methodology and budgetary figures for an “escalated” Adaptive CIP. Estimates of costs are presented for the wastewater facilities categories previously discussed:

- In-Progress Projects
- Current integration opportunities
- Future integration opportunities (concept options)
- Estimated and Projected CIP

The expenditures for each of these project categories were developed in 2017 dollars. Recognizing that the City will not implement all projects identified at once, costs for the near-term, mid-term and long-term projects were adjusted to account for inflation, escalated at a rate of 3 percent per year.

To compare costs between different implementation phases, the project costs were then brought back to a present value using a discount rate of 2 percent per year. Discounting the escalated costs yields a net present value and reflects the future escalated values in today's 2017 dollars. These escalation and discount factors were determined based on industry standards and are consistent with other One Water LA documents.

Figure ES.26 shows the total Adaptive CIP is \$6,062 million over a 20 plus year timeframe. The near-term planning phase shows a total of \$1,519 million or \$506 million per year. The mid-term planning phase shows a total of \$757 million or \$75.7 million per year. The long-term planning phase shows a total of \$3,786 million or \$378.6 million per year.

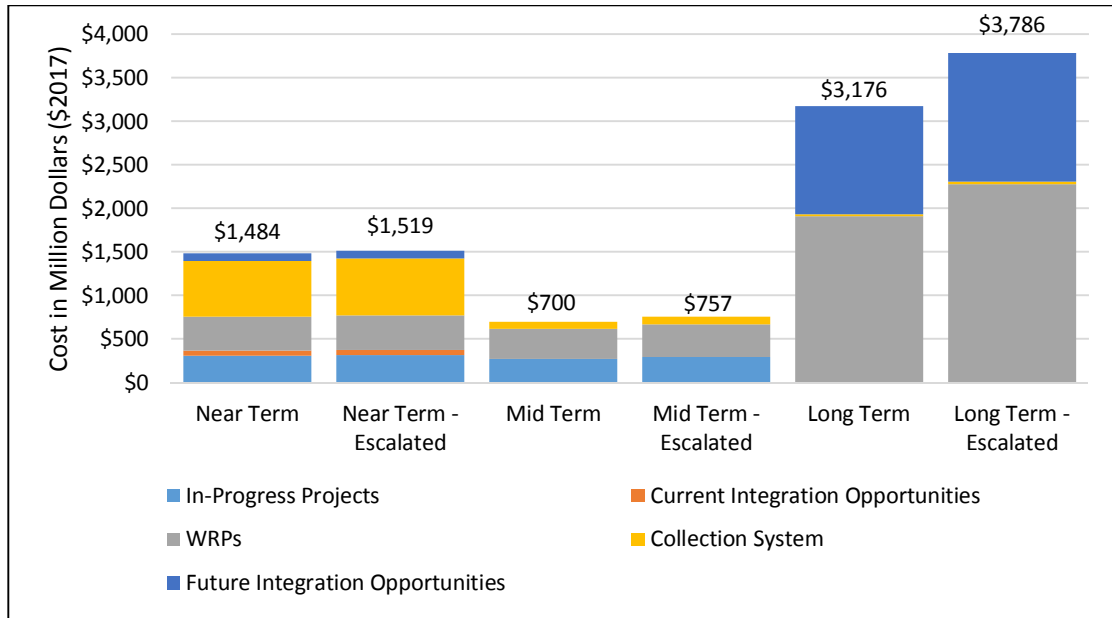

Figure ES.26 CIP Comparison of Net Present Values

The projected annual rate of CIP costs is the highest for the long-term. The mid-term presents the lowest rate of annual expenditures, with the near-term projected between the mid and long-term annual projected expenditures.

Figure ES.27 shows a proposed timeline for this WWFP Adaptive CIP. The durations are estimated based on the CIP and the development of the In-Progress Projects and concept options. The figure provides a better indication when certain costs would be incurred by the City for the CIP projects.

Overall, the most significant expenditures are for projects that would be implemented within the next three years and on work which is planned for execution in the long-term. The near-term work has already been scoped by the City and is the best defined of all the projects. The long-term work is primarily focused on the Priority A concept options which require specific triggers for these projects to proceed. The long-term expenditures also contain projects with the largest costs and impacts to the City's total wastewater system.

In order to implement the Mayor's water reuse goals it will be necessary for LASAN to take an active role in pursuing the specific triggers for the preferred portfolio options and begin planning for work that will start in the future.

| Timeline for Wastewater Facilities Plan | Near-Term | | | Mid-Term | | | | | | | | | | Long-Term | | | | | | | | | |
|-----------------------------------------------------------------------|-----------|-------|--------|----------|------|------|------|--------|------|------|------|------|------|-----------|-------|------|--------|--------|------|------|------|------|------|
| | 2018 | 2019 | 2020 | 2021 | 2022 | 2023 | 2024 | 2025 | 2026 | 2027 | 2028 | 2029 | 2030 | 2031 | 2032 | 2033 | 2034 | 2035 | 2036 | 2037 | 2038 | 2039 | 2040 |
| In-Progress Projects | | | | | | | | | | | | | | | | | | | | | | | |
| Hyperion AWWP to LAX and Scattergood ⁽¹⁾ | \$38M | | | \$92M | | | | | | | | | | | | | | | | | | | |
| LAGWRP NPR Expansion | \$73M | | | | | | | | | | | | | | | | | | | | | | |
| HWRP Delivery Expansion to 70 mgd for WBMWD and Harbor ⁽²⁾ | \$16M | | | | | | | | | | | | | | | | | | | | | | |
| GWR with AWWP at DCTWRP | | | \$370M | | | | | | | | | | | | | | | | | | | | |
| Current Integration Opportunities | | | | | | | | | | | | | | | | | | | | | | | |
| Rancho Park WRF | \$58M | | | | | | | | | | | | | | | | | | | | | | |
| Water Reclamation Plants | | | | | | | | | | | | | | | | | | | | | | | |
| Capital Projects from WCIP | \$178M | | | \$71M | | | | | | | | | | | \$10M | | | | | | | | |
| R&R from WCIP | \$184M | | | | | | | \$115M | | | | | | | \$12M | | | | | | | | |
| Climate Resiliency Projects | | \$27M | | | | | | | | | | | | | \$14M | | | | | | | | |
| Projected Capital Project | | | | \$59M | | | | | | | | | | | | | | \$136M | | | | | |
| Projected R&R Projects | | | | \$100M | | | | | | | | | | | | | | \$518M | | | | | |
| Collection System | | | | | | | | | | | | | | | | | | | | | | | |
| Collection System | \$641M | | | \$78M | | | | | | | | | | | \$22M | | | | | | | | |
| Future Integration Opportunities | | | | | | | | | | | | | | | | | | | | | | | |
| #22 East-West Valley Interceptor Sewer | \$85M | | | | | | | | | | | | | | | | | | | | | | |
| #15 DCTWRP to LA Aqueduct Filtration Plant | | | | | | | | | | | | | | | | | \$220M | | | | | | |
| #17 LAGWRP to Headworks Reservoir | | | | | | | | | | | | | | | | | | \$120M | | | | | |
| #13 MBR at HWRP to Regional System | | | | | | | | | | | | | | | | | | \$900M | | | | | |

(1) The estimated capital cost is for the installation of a 5 mgd facility, the Phase 1 cost of \$38M is included in the \$130M.

(2) An additional cost of \$400 million could be incurred in the future should 70 mgd of MBR treatment be installed at HWRP.

(3) TIWRP Expansion to 12 mgd was completed during the finalization of the WWFP. For this reason, it has not been included in the total cost of the In-Progress Projects.

Figure ES.27 – Timeline for Wastewater Facilities Plan

One Water LA 2040 Plan

INTRODUCTION

The City of Los Angeles Sanitation Department (LASAN), is responsible for implementing, operating, maintaining, and monitoring a reliable, and sustainable system that conveys and treats wastewater in a cost efficient and environmentally prudent manner while complying with all regulatory permits. LASAN is also playing an important role in meeting the Mayor's water supply goal of sourcing 50 percent of the City's water supply locally by 2035 by appropriately evaluating their WRPs for future opportunities. To add to its role in protecting public health and the environment, LASAN has significant responsibilities for the city-wide stormwater system and solid waste services. LASAN serves over 4 million residential and industrial customers in the City. Additionally, LASAN also provides conveyance and treatment services for an estimated 600,000 residences outside of the City through discharges from its 29 contract agencies.

The Wastewater Facilities Plan (WWFP) describes the City's existing wastewater collection system and water reclamation plants (WRPs), as well as the recommended improvements to meet future flow conditions. Both existing system and future system improvements are combined in a comprehensive, adaptive capital improvement plan (CIP), which is documented in detail in the following chapters of the WWFP. The WWFP is Volume 2 of 10 volumes of the One Water LA 2040 Plan (Plan).

1.1 BACKGROUND

The City of Los Angeles (City) recently embarked on the One Water LA 2040 Plan. This Plan will provide a strategic vision and a collaborative approach for integrated water management. In 2006, the City completed and adopted its first Water Integrated Resources Plan (Water IRP). This plan was the start of a paradigm shift for the City and resulted in significant achievements. Since then, the water landscape in the City has changed with increased demands, new regulations, and threats of climate change.

In response to these changes and to help achieve water sustainability, the City initiated the One Water LA 2040 Plan. This Plan builds upon the success of the Water IRP, which had a planning horizon to year 2020. The One Water LA 2040 Plan takes a holistic and collaborative approach, to consider all water resources from surface water, groundwater, potable water, wastewater, recycled water, dry-weather runoff, and stormwater as "One Water." The Plan identifies multi-departmental and multi-agency integration opportunities to manage water in a more efficient, cost effective, and sustainable manner.

The One Water LA 2040 Plan represents the City's continued and improved commitment to proactively manage all its water resources and implement innovative solutions, driven by the Sustainable City pLAn. The Plan will help guide strategic decisions for integrated water projects, programs, and policies within the City.

1.2 WASTEWATER FACILITY PLAN PURPOSE

The purpose of the WWFP is to guide LASAN with its decision making related to the implementation of system improvements to its wastewater collection system and treatment facilities. The WWFP provides the documentation required to make informed decisions when considering investments to repair and replace, or enhance existing facilities and construct new water conveyance or treatment facilities through year 2040.

This WWFP is an update of the Plan that was included in the Water IRP. This WWFP incorporates expansions, upgrades, and enhancements made since 2006 and builds upon the Los Angeles Department of Water and Power's (LADWP) 2015 Urban Water Management Plan (UWMP). It is anticipated that the WWFP will also be updated in approximately ten years to incorporate system modifications as well as changes in flow conditions, regulatory framework, and overall vision for wastewater system operations and water reuse.

While One Water LA Objective 4 provided direction to: Improve local water supply reliability by increasing capture of stormwater, conserving potable water, and expanding water reuse. To support the accomplishment of the Sustainable City pLAn goal and One Water LA Objective 4, the One Water LA 2040 Plan takes a comprehensive approach. The ability for Water Reclamation Plants to enhance the local water supply are focused on the following:

- Non-potable reuse
- Potable water reuse
- Treatment of dry-weather runoff
- Storage and treatment of stormwater

Implementation of these potential water reuse opportunities would increase and diversify the City's local water portfolio. All of the approaches are required for a comprehensive plan, however, water reuse is key to maximizing the water sources available. The WWFP provides recommendations for each plant on how to best utilize the water reuse opportunities, providing environmental stewardship, implementing non-potable reuse, and potable reuse for groundwater, raw water and treated water augmentation. Additionally, the WWFP addresses One Water LA Objective 5 which provides direction to: Implement, monitor, and maintain **a reliable wastewater system** that safely conveys, treats, and reuses wastewater while also reducing sewer overflows and odors. Projects are also identified at each water reclamation plant that are needed to maintain safe and reliable operations.

1.3 RELEVANT PLANNING DOCUMENTS AND STUDIES

A number of relevant planning documents and studies were leveraged in the developed of the WWFP. Planning documents used include the following:

- LADWP Urban Water Management Plan (UWMP), 2015;
- Recycled Water Master Planning Long Term Concept Report, 2012
- Recycled Water Master Planning Non-Potable Reuse Master Planning Report, 2012
- Recycled Water Master Planning Groundwater Replenishment Master Planning Report, 2012
- Integrated Resources Plan, 2006
- Specific project Concept Reports and Environmental Impact Reports (EIR)

Chapter 1 of the Summary Report (see Volume 1) describes in greater detail. These documents and studies were used in collaboration with discussions from City staff. For a complete list of references used in the WWFP, please see Appendix A.

1.4 WASTEWATER FACILITY PLAN ORGANIZATION

The WWFP plan is organized into eleven (11) chapters, as outlined in Table 1.1. The WWFP first outlines the study area and provides background as to regulatory and water reuse options that will be used in the future needs analysis provided in each respective WRP chapter. The subsequent chapters discuss the collection system and the City's four WRPs in both their current state and potential future alternatives. The WWFP also evaluates the climate risk of both the collection system and WRPs. The WWFP concludes with an adaptive capital improvement plan that connects projects for continued operation of City infrastructure with potential future options and presents an overall plan for implementation phasing and costs.

| Table 1.1 Wastewater Facilities Plan Organization Wastewater Facilities Plan One Water LA 2040 Plan | |
|--------------------------------------------------------------------------------------------------------------------------------|--------------------------------------------------------------------------------------------------------------------------------------------------------------------------------------------------------------------|
| Chapter | Description |
| 1.0 Introduction | Chapter 1.0 discusses the purpose of the WWFP, planning documents used, and the organization of the plan. |
| 2.0 Basis of Planning | Chapter 2.0 establishes the study area, provides an overview of flow projections, describes water reuse options, potential future regulations, and design and sizing criteria assumptions used for the evaluation. |

| Table 1.1 Wastewater Facilities Plan Organization Wastewater Facilities Plan One Water LA 2040 Plan | |
|--------------------------------------------------------------------------------------------------------------------------------|-------------------------------------------------------------------------------------------------------------------------------------------------------------------------------------------------------------------------------------------|
| Chapter | Description |
| 3.0 Wastewater Collection System | Chapter 3.0 provides an overview of the City's existing collection system, and planned major projects |
| 4.0 Hyperion Water Reclamation Plant (HWRP) | Chapter 4.0 discusses HWRP's existing treatment facilities and current performance, projected wastewater flows to the plant, planned and in-progress projects as well as potential future concept options. |
| 5.0 Donald C. Tillman Water Reclamation Plant (DCTWRP) | Chapter 5.0 discusses DCTWRP's existing treatment facilities and current performance, projected wastewater flows to the plant, in-progress projects, and potential future concept options. |
| 6.0 Los Angeles-Glendale Water Reclamation Plant (LAGWRP) | Chapter 6.0 discusses LAGWRP's existing treatment facilities and current performance, projected wastewater flows to the plant, and potential future concept options. |
| 7.0 Terminal Island Water Reclamation Plant (TIWRP) | Chapter 7.0 discusses TIWRP's existing treatment facilities and current performance, projected wastewater flows to the plant, planned projects and potential future concept options. |
| 8.0 Potential Future Water Reclamation Plants | Chapter 8.0 expands on the option of potential future WRPs to provide on-site treatment for smaller service areas. |
| 9.0 Biosolids Management | Chapter 9.0 provides an overview of existing biosolids management, existing biosolids production at HWRP and TIWRP, summary of biosolids technologies, and recommendations for future biosolids management. |
| 10.0 Climate Risk and Resilience Assessment for Infrastructure | Chapter 10.0 evaluates the climate risk and resilience for the collection system and WRPs. This chapter also provides suggested projects to adapt and mitigate to changing climate conditions. |
| 11.0 Wastewater Facilities Adaptive Capital Improvement Plan | Chapter 11.0 presents a capital improvement plan based for the collection system and WRPs based on timing and project type. This adaptive CIP is combined with an evaluation of potential projects to yield total estimates for the City. |

1.5 ACKNOWLEDGEMENTS

The development of the WWFP was accomplished with significant contribution from LASAN staff, LADWP staff, Bureau of Engineering (BOE) staff, City Hall, and the One Water LA team.

-This Page Left Blank Intentionally-

BASIS OF PLANNING





The development of the WWFP relies on existing and projected data. The basis of planning used to develop the WWFP includes the planning horizon, study area, wastewater flows, and regulatory requirements. These planning parameters are briefly described below, and are described in further detail in the following subsections.

- **Planning Horizon:** The planning horizon of the WWFP is year 2040. The intermediate planning period is divided into three phases: near-term (2018-2020); mid-term (2021-2030); and long-term (2031-2040).
- **Study Area:** The study area of the WWFP closely coincides with the City boundary and encompasses approximately 533 square miles. However, certain elements of the WWFP, such as flow, economics, and recycling opportunities transcend City boundaries when considering contract agencies and cities, as well as other involved neighboring entities. The study area is described in further detail in Section 2.1.
- **Wastewater Flows:** Wastewater flow projections are an important foundation for facility planning. Due to substantial water conservation in the past decade, demand hardening, and moderate growth, the City's combined wastewater flows are projected to increase from 328 million gallons per day (mgd) in the analysis year (2016) to 376 mgd by 2040. Wastewater flow projections by plant are described in further detail in Section 2.2.
- **Regulatory Requirements:** The WWFP considers both existing and anticipated changes to regulations that pertain to wastewater conveyance, wastewater treatment, effluent discharge, and water reuse. The applicable regulatory framework is described in further detail in Section 2.4.

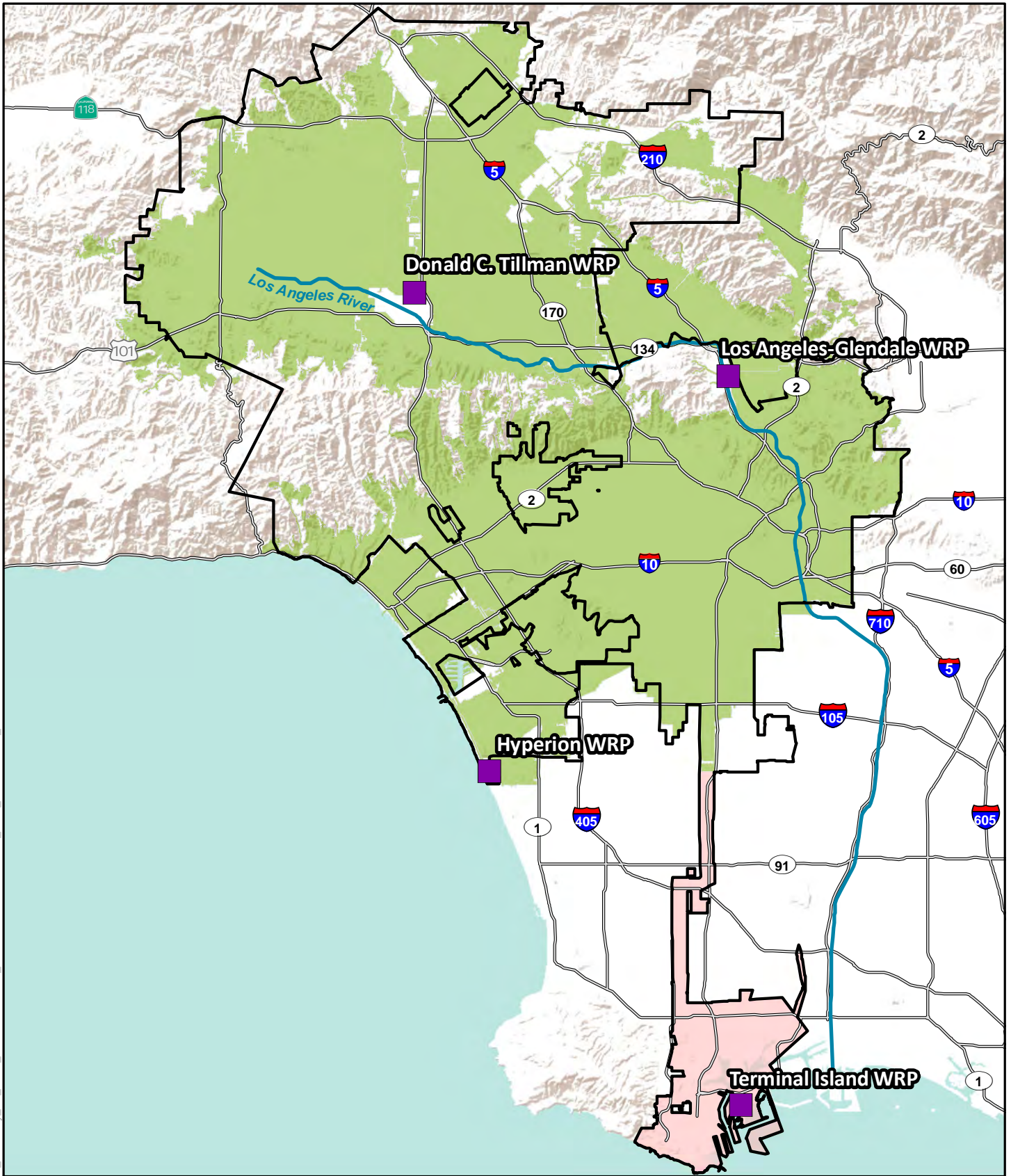
2.1 WASTEWATER SYSTEM SERVICE AREA

The City owns and operates their wastewater collection, conveyance, and treatment system. The current network serves nearly 4,000,000 residents, as well as commercial, institutional, and industrial enterprises throughout the City. The City also provides conveyance and treatment services for an estimated 600,000 residences outside of its service area through 29 contractual agreements. Figure 2.1 shows the City's service area and the four water reclamation plants.



-  Existing Water Reclamation Plant (WRP)
-  City of LA Boundary
-  Hyperion Service Area (HSA)
-  Terminal Island Service Area (TISA)

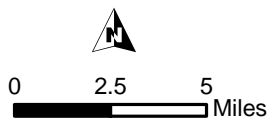

Figure 2.1
City of Los Angeles Wastewater
System Service Area
One Water LA 2040 Plan

2.1.1 Existing Collection System and Water Reclamation Plants

The wastewater collection system infrastructure includes over 6,700 miles of major interceptors and mainline sewers, 43 pumping plants, and various diversion structures and other support facilities, such as corporation yards. The wastewater is collected and conveyed through this network to one of the four water reclamation plants owned and operated by the City listed below.

1. Hyperion Water Reclamation Plant (HWRP). This plant is located in Playa del Rey along the Pacific Ocean, just south of the Los Angeles International Airport (LAX);
2. Donald C. Tillman Water Reclamation Plant (DCTWRP). This plant is located in the San Fernando Valley, in the Sepulveda Basin Recreation Area;
3. Los Angeles-Glendale Water Reclamation Plant (LAGWRP). This plant is located east of Interstate 5 (I-5), east of Griffith Park, and is co-owned with the City of Glendale;
4. Terminal Island Water Reclamation Plant (TIWRP). This plant is located on an island in the Los Angeles Harbor, approximately 20 miles south of downtown Los Angeles.

2.2 WASTEWATER FLOW PROJECTIONS

Wastewater flow projections are key in planning for the future. Projections are developed by examining historical and existing flows to forecast future usage through hydraulic modeling and simulations. The results from this analysis helps to identify shortages, reuse opportunities, and conservancy efforts which in turn determines future projects specific to individual service areas and WRPs.

2.2.1 Methodology

Wastewater flow projects were developed from extensive discussions with City staff and reference from LADWP's 2015 UWMP. For additional details see Volume 8.

2.2.2 Historical and Existing Flows

Knowledge of future flow projections is vital to CIP planning and management of the wastewater system assets for collection and treatment. Estimating future flows requires an analysis of historical flows and existing flows in order to account for recent trends or changes in the system.

Figure 2.2 compares the 2006 Water IRP projections (2005-2020), the actual annual average wastewater flows (2002-2016), and the One Water LA 2040 Plan flow projections. As shown in the figure, the Water IRP projected approximately 451 mgd of wastewater influent within the HSA and TISA boundaries in 2015. The actual average annual wastewater influent flow in 2015 for these service boundaries were significantly lower, totaling approximately 337 mgd. This yields a difference of 114 mgd between the projected and the actual flows. This significant difference of influent flows can largely be attributed to the City's successful water conservation efforts. The Plan wastewater influent projections account for conservation efforts and develop flow projections based on estimated conservation, increased population and expected system growth. As a result, the 2020 flow projections differ by 131 mgd between the Water IRP and the Plan projections.

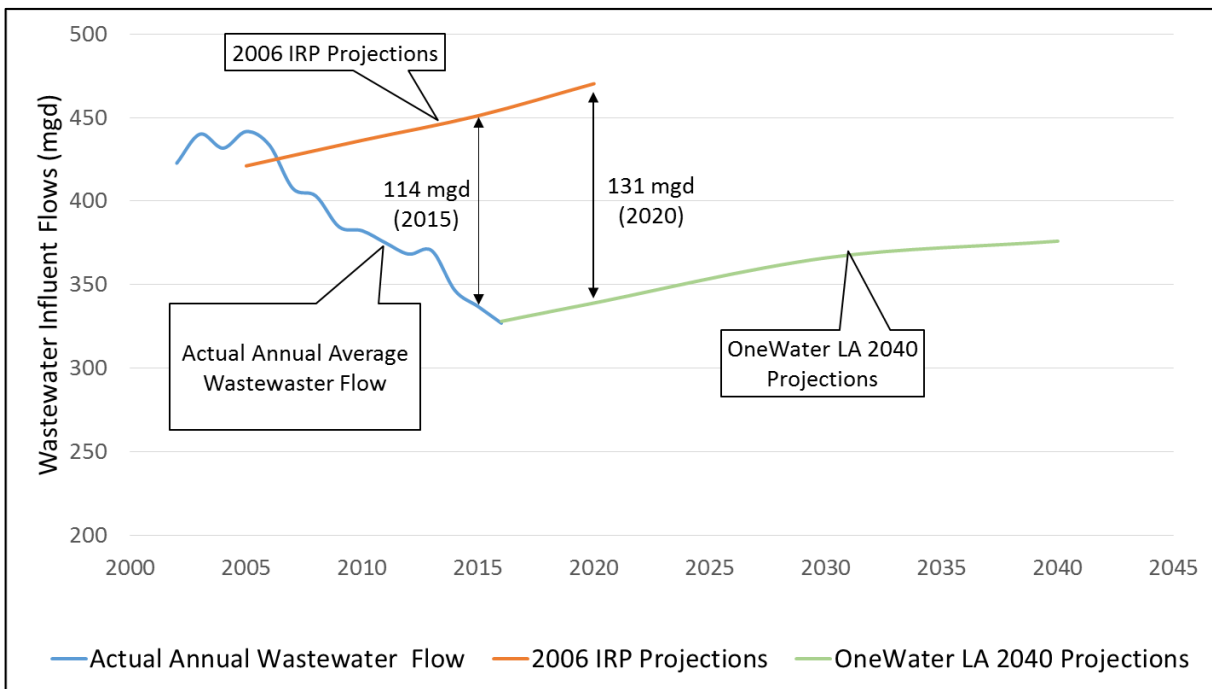

Figure 2.2 Projected and Historical Average Annual Wastewater Flows

2.2.3 Future Wastewater Flows Summary

Future wastewater flows are expected to increase due to increased population, commercial, and industrial activity. LADWP's 2015 UWMP, in conjunction with SCAG census data, projects a growth of an additional 493,200 people within the City by 2040. The population is expected to continue to grow over the next 25 years at a rate of 0.5 percent annually, which is a reduction to the historical 1 percent annual growth rate that occurred between 1980 and 2010. Population growth will lead to an increase in commercial and industrial activity, likely resulting in an increase in wastewater flows in the City's service area. In general the LADWP UWMP states that dry weather wastewater influent projections for the WRPs are expected to increase by 20 percent over the next 25 years.

Along with population growth, wastewater flows will also be influenced by economic activity, weather, and water conservation. However, once conservation efforts are maximized, the demand values are "hardened" and greater efforts are required to create substantive changes.

Figure 2.3 shows total wastewater flows are projected to increase by 2040, allowing for increased reuse opportunities. Included in these future flow projections are additional potential stormwater flows. The City has already implemented numerous dry weather LFDs throughout the City increasing the potential for water reuse. LFDs that route dry weather stormwater flows into the sewer collection system via a pumping facility. These dry weather stormwater flows to increase flows to the WRP increasing the potential for reuse. The City plans to implement a policy to reduce the overall dry weather runoff while also expanding the number of LFDs to maximize dry weather capture. It is anticipated that the City can capture an additional 6,200 acre-feet per year (AFY) or 6.5 mgd of flow with LFDs. Depending on which LFDs are built, this could increase influent flows particularly at the inland plants, DCTWRP and LAGWRP. Proposed LFD locations are shown on Figure 2.4.

Current and future flow projections for each plant are summarized in Table 2.1. The low flow diversions (LFD) shown on Figure 2.4 are also included in the flow projections below. Knowledge of future flow projections is vital to CIP planning and management of the wastewater system assets, collection, and treatment.

| Table 2.1 Projected Wastewater Flows Wastewater Facilities Plan One Water LA 2040 Plan | | | | |
|-------------------------------------------------------------------------------------------------------|-------------------------------------------------------------|----------------|----------------|----------------|
| Water Reclamation Plant (WRP) | Projected Wastewater Flows by Year^(1,2,3) | | | |
| | 2016 | 2020 | 2030 | 2040 |
| Hyperion | 250 mgd | 256 mgd | 275 mgd | 283 mgd |
| Donald C. Tillman | 47 mgd | 46 mgd | 51 mgd | 53 mgd |
| Los Angeles-Glendale | 17 mgd | 21 mgd | 22 mgd | 22 mgd |
| Terminal Island | 14 mgd | 16 mgd | 18 mgd | 18 mgd |
| Totals | 328 mgd | 339 mgd | 366 mgd | 376 mgd |
| Notes: | | | | |
| (1) Flows are rounded to the nearest mgd. | | | | |
| (2) These LFDs are assumed to be implemented starting in Year 2030. | | | | |
| (3) mgd = million gallons per day | | | | |

As shown in Table 2.1 and on Figure 2.3, the total system net flow will increase by 13 percent by 2040.

The increased flows that are anticipated to be treated at the inland plants (DCTWRP and LAGWRP) will result in a reduction in the amount of flow that is treated at HWRP. The flows

to TIWRP are anticipated to increase the least due to the build out of the sewer service area, however there are discussions to bring additional sewer flow into the service area.

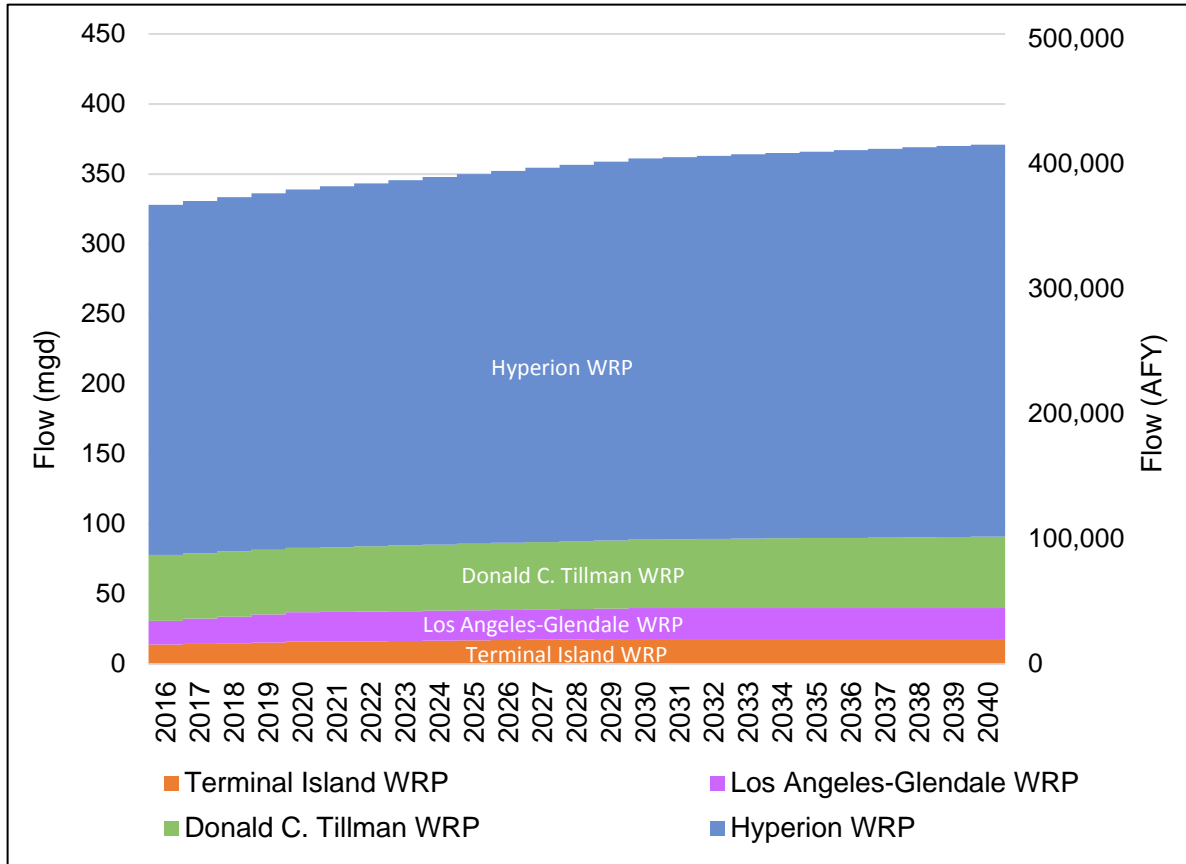
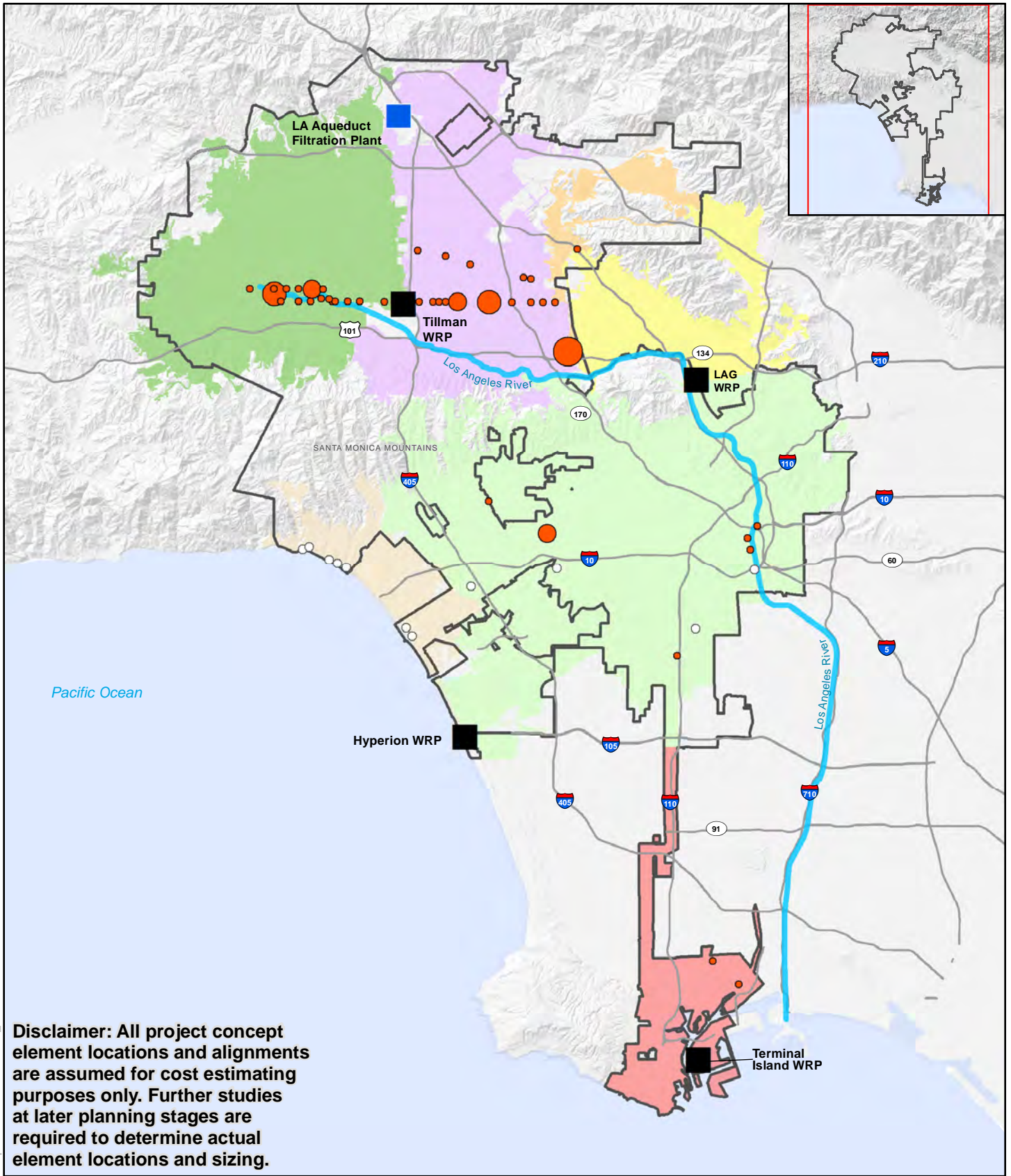

Figure 2.3 Projected Wastewater Flows by Plant



Disclaimer: All project concept element locations and alignments are assumed for cost estimating purposes only. Further studies at later planning stages are required to determine actual element locations and sizing.

Legend

- Existing Water Reclamation Plant (WRP)
- Existing Water Filtration Plant
- City of Los Angeles

- Proposed Low Flow Diversion Locations Inflow (MGD)
- < 0.2
 - 0.3 -0.4
 - 0.5-0.6
 - 0.7-0.8
 - >1.0



Hillshade Source: CalAtlas
<http://www.atlas.ca.gov>

Figure 2.4
Low Flow Diversions
 One Water LA 2040 Plan

2.3 WASTEWATER REUSE OPTIONS

LASAN currently has in place water reuse programs at each of its existing water reclamation plants. However, increased influent flows and new demands for drought-proof supplies may provide additional opportunities for recycling and water reuse. As water reuse regulations continue to evolve and new customers are identified, the City will continue to expand its water reuse efforts to enhance water sustainability. Depending on the level of treatment, recycled water is categorized by its use: non-potable reuse and potable reuse. Potable reuse, in turn, includes subcategories of groundwater augmentation, raw water augmentation and treated water augmentation.

2.3.1 Non-Potable Reuse

Currently, recycled water is most commonly used for non-potable (not for drinking) purposes, such as agriculture, landscape irrigation, and industrial uses. Other non-potable applications include dust control, construction activities, concrete mixing, and artificial lakes. The use of non-potable water reduces the amount of potable water used for the aforementioned purposes and thereby reduces the City's reliance on imported water.

Non-potable reuse must be compliant with regulations set forth in California Code of Regulations Title 22 (Title 22), which specifies the allowed uses of recycled water at various treatment levels. These treatment levels are defined by both the processes by which the wastewater has been treated, and by water quality criteria for turbidity and indicator microorganisms. The categories include un-disinfected secondary recycled water; various levels of disinfected secondary recycled water; and disinfected tertiary recycled water. The current effluent quality at DCTWRP, LAGWRP, and TIWRP meets these standards. Effluent from TIWRP is of advanced water treatment (AWT) quality, representing higher quality than the baseline non-potable standards.

2.3.2 Potable Reuse

When recycled water is subject to advanced treatment and its end use is the replenishment of drinking water supplies, this is referred to as potable reuse. Potable reuse strategies can be categorized as follows:

- Potable reuse with groundwater augmentation - Projects that would spread (infiltrate) or directly inject recycled water into a groundwater basin that could be used as potable water after extraction and further treatment.
- Potable reuse with raw water augmentation prior to delivery - Projects that would deliver advanced treated recycled water (purified water) to a conventional water treatment plant before distributing into a potable water system.
- Potable reuse with treated water augmentation prior to delivery into the potable water distribution system - Projects that would deliver advanced treated recycled water (purified water) directly to a potable water system.

Because they ultimately provide drinking water supply, all potable reuse systems are subject to the Maximum Contaminant Levels (MCLs) defined by the United States Environmental Protection Agency (US EPA). In addition to meeting these MCLs, there are criteria that potable reuse systems must meet to ensure sufficient removal of pathogenic organisms and trace constituents. These requirements vary somewhat based on the system configuration, and are described below.

2.3.2.1 Groundwater Augmentation

Potable reuse with groundwater augmentation consists of a series of treatment steps to meet MCLs, water reuse criteria, and basin-specific criteria so that recycled water can be used to replenish drinking water aquifers. Regulations are in place in California for this approach, and multiple systems are in operation throughout the state. There are two approaches to groundwater augmentation:

- *Spreading Basins* - The regulations for spreading basins require the treatment train to consist of at least three separate treatment processes and achieve at least 12-log enteric virus reduction, 10-log *Giardia* cyst reduction and 10-log *Cryptosporidium* oocyst reduction. Advanced treatment can be used, or these log removal requirements can be met via a combination of tertiary wastewater treatment and soil aquifer treatment. To claim credit for soil aquifer treatment, studies of travel time in the groundwater basin are required. Using recycled water for groundwater recharge through surface application typically requires some degrees of blending with non-recycled water sources, such as potable water or stormwater. Blending requirements depend on the level of treatment that has been applied to the recycled water. Typically, a project that uses advanced treatment can, over time, reduce the blending requirement to zero.
- *Injection Wells* - The treatment process for direct injection requires full advanced treatment. Treatment requirements for direct injection are more stringent because credit is not granted for soil aquifer treatment, but blending with non-recycled water sources may not be required. Similar to the requirements for spreading basins, the treatment train must consist of at least three separate treatment processes and achieve at least 12-log enteric virus reduction, 10-log *Giardia* cyst reduction and 10-log *Cryptosporidium* oocyst reduction. The advanced treatment steps must also include an oxidation process that achieves 0.5-log reduction of 1,4-dioxane, or a defined removal of other surrogates for trace constituents.

2.3.2.2 Raw Water Augmentation

Regulations for potable reuse through the augmentation of raw water supplies such as reservoirs are in final draft form and are near completion, pending the public comment period. The final draft regulations build on the regulations for groundwater recharge, and similarly require full advanced treatment to achieve removal of pathogens and chemical contaminants.

As currently allowed under these draft regulations, potable reuse with raw water augmentation consists of full advanced treatment of wastewater, followed by addition to a surface water reservoir for blending into the raw water supply for a drinking water system. Some hydraulic modeling or tracer studies on the reservoir may be necessary, and the requirements for treatment depend on the size of the reservoir into which recycled water is discharged:

- For reservoirs with a hydraulic residence time of at least 180 days, the treatment requirements are similar to the injection well option for a Groundwater Replenishment Reuse Project (GRRP). This is the default regulatory minimum, and lower residence times can only be approved on a case-by-case basis.
- For reservoirs with a hydraulic residence time of 120 days or less, at least one additional log removal of each category of pathogen is required over and above the 12 / 10 / 10 requirement.
- In all cases, the reservoir must have a hydraulic residence time of at least 60 days, to provide for sufficient response time in the event of a treatment system failure.

2.3.2.3 Treated Water Augmentation

In December 2016 the State Water Resources Control Board (SWRCB) delivered a report to the California State Legislature related to potable reuse dealing with the feasibility of treated water augmentation, also referred to as direct potable reuse. The report's findings reflect input from two independent groups; an expert panel of scientists and engineers, and an advisory group of stakeholders. The report concluded that it is feasible to develop and adopt regulation for using recycled water as drinking water, provided that certain research and key knowledge gaps are addressed. The adoption of regulations for treat water augmentation/direct potable reuse will not take place until research and knowledge gaps are appropriately addressed.

2.4 REGULATORY DRIVERS

In anticipation of potential regulatory changes, the possible future regulatory framework was considered as a facilities planning parameter. Regulations affecting water reclamation plants in Los Angeles are established by a variety of agencies, such as the U.S. EPA, Los Angeles Regional Quality Water Control Board (RWQCB-LA), Division of Drinking Water (DDW), and the South Coast Air Quality Management District (SCAQMD).

EPA delegates the regulatory oversight to the DDW and the RWQCB-LA. The RWQCB-LA issues permits for the WRPs. A National Pollution Discharge Elimination System (NPDES) permit, which governs the discharge from the existing WRPs, is issued by the RWQCB-LA. A NPDES permit can contain discharge requirements for total maximum daily loads (TMDLs), sanitary sewer overflow (SSO) controls, and various regulations outlining receiving waters and recycled water quality requirements.

LASAN has water reuse programs at each of its four water reclamation plants. These regulations are governed by the DDW and the RWQCB-LA in the California Code of Regulations Title 22, Division 4, and Chapter 3 (Title 22). These regulations establish treatment and water quality requirements for various qualities of recycled water, which are dependent upon the intended end use.

In addition to the regulations that have been established, the changing regulatory environment has the ability to impact the WRPs. Table 2.2 summarizes potential regulatory drivers that may impact future requirements at each of the water reclamation plants. This list is not intended to be exhaustive, but rather to provide an overview of how plants could be impacted as a result of potential future regulations.

| Table 2.2 Potential Regulatory Drivers Wastewater Facilities Plan One Water LA 2040 Plan | | | | |
|-------------------------------------------------------------------------------------------------------------------------------------------------------------------------------------------------------------------------------------------|-------------|---------------|---------------|--------------|
| Regulatory Driver | HWRP | DCTWRP | LAGWRP | TIWRP |
| Potable Reuse with Groundwater Augmentation | X | X | X | X |
| Potable Reuse with Raw Water Augmentation | X | X | X | X |
| Potable Reuse with Treated Water Augmentation | X | X | X | X |
| Increased Nitrogen standards for discharge to inland waters | | X | X | |
| Brine disposal regulations | X | X | X | X |
| Nitrogen standards for Ocean discharge | X | | | X |
| Increased SCAQMD Emission Standards | X | | | X |
| <u>Note:</u> (1) The program of diverting organics from solid waste to WRPs for treatment (HWRP-TIWRP) may result in increased methane production combustion impacting compliance with potentially more stringent SCAQMD requirements. | | | | |
| <u>Abbreviation:</u> NOX = Nitrogen Oxide | | | | |

Table 2.2 shows that all four water reclamation plants could be impacted if regulations governing the discharge of brine are passed. Also, all four water reclamation plants may require upgrades should the potable reuse with treated water augmentation regulations be approved and this strategy be subsequently implemented by LASAN. The listed potential SCAQMD regulations would only apply to HWRP and TIWRP where solids are processed and methane gas could be produced. Based on the matrix provided in Table 2.2, the

following tables, Table 2.3, Table 2.4, and Table 2.5, detail the existing and future regulatory drivers for each WRP.

| Table 2.3 HWRP Potential Regulatory Drivers Wastewater Facilities Plan One Water LA 2040 Plan | |
|-------------------------------------------------------------------------------------------------------------------------------------------------------------------------------------------------------------------------------------------------------------------------------------------------------------------------------------------------------------------------------------------------------------------------------------------------------------------------------------------------------------------------------------------------------------------------------------------------------------------------------------------------------------------------------------------------|---------------------------------------------------------------------------------------------------------------------------------------------------------------------------------------------------------------------------------------------------------------------------------------------------------------------------------------------------------------------------------------------|
| Regulatory Drivers | Potential Process(es) Requirements for Compliance |
| Potable Reuse with Treated Water Augmentation Regulations | Convert secondary treatment process to NDN and install advanced treatment process such Ozone, BAC, MF, RO, UV/AOP ⁽¹⁾ |
| Potable Reuse with Groundwater Augmentation Regulations | Convert secondary treatment process to NDN and install advanced treatment process such MF, RO, UV/AOP |
| Potable Reuse with Raw Water Augmentation Regulations | Convert secondary treatment process to NDN and install advanced treatment process such MF, RO, UV/AOP |
| Nutrient Removal for Ocean discharge | Requires the implementation of a biological system, including improved or new clarifiers, to produce an effluent with low nitrogen levels and adaptability for potable reuse. Evaluation of the current HPO system to achieve compliance with the new standards and potential conversion to a biological process utilizing air and covered aeration tanks with air treatment ⁽²⁾ |
| AQMD Emission Standards for methane and NOX ⁽³⁾ | Installation of gas cleanup and low emission flares to meet lower NOX standards |
| Organic Removal from Landfill | Delivery of such material will require increased digester gas and solids handling capacity |
| <p><u>Notes:</u></p> <p>(1) Ongoing full scale operation at TIWRP's Advanced Water Purification Facility and pilot work at DCTWRP and HWRP may inform future decisions related to AWT processes implemented</p> <p>(2) To assist with nitrogen removal and improve the control of the activated sludge system consideration should be given to centrate treatment</p> <p>(3) The program of diverting organics from solid waste to HWRP may result in an</p> <p><u>Abbreviations:</u></p> <p>BAC = biologically activated carbon, MF =microfiltration, RO = reverse osmosis, UV/AOP = ultraviolet advanced oxidation process, NDN = nitrification/denitrification, HPO = high purity oxygen</p> | |

Modifications at HWRP may be required to meet potential future regulatory drivers. Should LASAN chose to implement potable reuse, secondary treatment process upgrades and an AWT process would be required. If solid waste organics are diverted to HWRP with a resulting increase in methane produced, this may trigger requirements for more stringent air emission controls on existing power generation systems.

DCTWRP and LAGWRP have similar processes and location, as such, their regulatory drivers are also similar and are described in Table 2.4. These regulatory drivers are largely driven by the future direct and indirect potable reuse regulations, as well as water nitrogen limits and brine discharge due the inland locations.

| Table 2.4 DCTWRP and LAGWRP Potential Regulatory Drivers Wastewater Facilities Plan One Water LA 2040 Plan | |
|-----------------------------------------------------------------------------------------------------------------------------------------------------------------------------------------------------|--------------------------------------------------------------------------------------------------------------------------------------------------------------------------------------------------------------------------------------------------------------------------------------------------------------------------------|
| Regulatory Drivers | Potential Process(es) Requirements for Compliance |
| Potable Reuse with Treated Water Augmentation Regulations | Install advanced treatment process such as Ozone, BAC, MF, RO, UV/AOP ⁽¹⁾ |
| Potable Reuse with Groundwater Augmentation Regulations | No change to current process(es) – surface spreading Install advanced treatment process such as Ozone, BAC, MF, RO, UV/AOP ⁽¹⁾ – injection |
| Potable Reuse with Raw Water Augmentation Regulations | Install advanced treatment processes such MF, RO, UV/AOP ⁽¹⁾ |
| Nitrogen standards discharge to inland waters | Enhancement of nitrogen removal processes, increase in peak flow detention time through equalization, optimization of the activated sludge (AS) systems or installation of membrane bioreactor (MBR) or a combination of the above and research of alternative treatment technologies for the more stringent nitrogen standard |
| Brine disposal regulations/ HWRP curtailment | Installation of Zero Liquid Discharge, deep well injection |
| <u>Note:</u> (1) Ongoing full scale operation at TIWRP's Advanced Water Purification Facility and pilot work at DCTWRP and HWRP may inform future decisions related to AWT processes implemented | |

As noted in the table above, potable reuse regulations related to utilizing spreading grounds would not require any modifications to the existing plant processes. However, groundwater augmentation using direct injection would require the addition of AWT processes similar to those currently being piloted at DCTWRP facilities. The results of the pilot will determine the optimum AWT process for implementation.

TIWRP is a tertiary WRP with an AWT process and solids handling. Table 2.5 highlights TIWRP's potential regulatory drivers.

| Table 2.5 TIWRP Potential Regulatory Drivers Wastewater Facilities Plan One Water LA 2040 Plan | |
|------------------------------------------------------------------------------------------------------------------------------------------------------------------------------------------------------|----------------------------------------------------------------------------------------------------------------------|
| Regulatory Drivers | Potential Process(es) Requirements for Compliance |
| Potable Reuse with Treated Water Augmentation Regulations | Install advanced treatment process such as Ozone, BAC, MF, RO, UV/AOP ⁽¹⁾ |
| Potable Reuse with Groundwater Augmentation Regulations | No change to existing |
| Potable Reuse with Raw Water Augmentation Regulations | No change to existing |
| AQMD Emission Standards for methane and NOX ⁽²⁾ | Installation of gas cleanup and low emission flares to meet lower NOX standards |
| Brine disposal regulations | Installation of a brine crystallization or identification of an alternate discharge point to the open ocean or LACSD |
| Notes: | |
| (1) Ongoing full scale operation at TIWRP Advanced Water Purification Facility will contribute to the data base for future treated water augmentation/direct water reuse regulations | |
| (2) The program of diverting organics from solid waste to TIWRP may result in an increase in methane production combustion impacting compliance with potentially more stringent SCAQMD requirements. | |

Because TIWRP treats wastewater to tertiary quality followed by an AWT process, the plant already meets current potable reuse water quality requirements. However, modifications to the existing AWT process may be required to meet new treated water augmentation/direct water reuse regulations. If solid waste organics are diverted to TIWRP with a resulting increase in methane gas produced, this may trigger requirements for more stringent air emission controls for gas utilization systems. New brine disposal restrictions may result in additional brine treatment limits to reduce brine discharge or incur capital costs to reroute the brine discharge location.

2.5 DESIGN AND SIZING CRITERIA

This section describes sizing assumptions used for implementation of potential alternatives. These assumptions were used to conceptually develop and size major infrastructure required for each potential concept option. A comprehensive list of sizing assumptions can be found in Volume 5.

2.5.1 Collection System

Design of sewer collection system improvements follow the City of Los Angeles', Bureau of Engineering's (BOE) Design Manual. Part F of the Design Manual lists the design criteria,

standards, policies, and procedures for engineers to follow in the design, construction, and post-construction of collection system improvements. The Design Manual is intended as a guideline and reference source and does not replace sound engineering judgment. Part F of the Design Manual is comprised of the following:

- F 100 – Introduction and General Information
- F 200 – Projection of Flows and Hydraulics of Sewers
- F 300 – Alignment of Sewers
- F 400 – Sewer Materials and Structures
- F 500 – Preparation of Plans
- F 600 – Sewer Construction
- F 700 – Pumping Plants and Force Mains
- F 800 – Operations and Maintenance
- F 900 – Sewer Rehabilitation

2.5.1.1 Pipeline and Pump Station

The collection and conveyance system are a series of interconnected pipes and pumps vital in transporting wastewater from the source to the WRPs. Future options discussed in the WWFP may require the addition of pipelines and/or pump stations to the City's existing collection system. The design criteria for these potential pipelines and pump stations are summarized in Table 2.6.

| Table 2.6 Pipeline and Pump Station Assumptions Wastewater Facilities Plan One Water LA 2040 Plan | | |
|------------------------------------------------------------------------------------------------------------------|-----------------------------|---------------------------|
| Component | Type | Size |
| Pressurized Pipelines | Maximum Velocity | 5 feet per second |
| Pump Stations (potable and recycled water) | Configuration Efficiency | 4 duty + 1 standby 75% |
| Lift Station | Configuration Efficiency | 4 duty + 1 standby 50% |

2.5.2 Water Reclamation Plants

As discussed in Section 2.3 and 2.4, future WRP recycling efforts will require advanced treatment in order to meet recycled water quality regulations. Many of the potential WRP future options require the addition of advanced treatment to the existing treatment process. For evaluation and cost estimating purposes, advanced water treatment assumptions, summarized in Table 2.7, were utilized to define the upgrades for each future option. Table 2.8 summarizes the assumption for Groundwater Recharge and Extraction.

| Table 2.7 Advanced Water Treatment Assumptions Wastewater Facilities Plan One Water LA 2040 Plan | |
|----------------------------------------------------------------------------------------------------------------------|----------------------------------------------------------------------------------------------------------------------------------------|
| Category | Assumption |
| Brine Loss | 20% of the flow |
| Equalization Storage Upstream of AWPf | 25% of daily flow |
| Engineered Storage Downstream of AWPf: | |
| Effluent pumped to another facility such as a reservoir or injection wells | 12.5% of daily flow |
| Effluent pumped to a distribution system for potable reuse | 100% of daily flow |
| WRP Treatment ⁽¹⁾ | Membrane bioreactors (MBR) prior to potable reuse |
| Potable Reuse Groundwater Augmentation Potable Reuse Raw Water Augmentation | Microfiltration (MF) or ultrafiltration (UF) ⁽²⁾ , reverse osmosis (RO) and ultraviolet advanced oxidation process (UV/AOP) |
| Potable Reuse Treated Water Augmentation | Ozone with biologically active filters (O ₃ /BAF), UF ⁽²⁾ , RO, and UV/AOP |
| Notes: | |
| (1) Demonstration Plant basis for MBR | |
| (2) MF/UF could possibly be part of an MBR process | |
| Abbreviations: | |
| UF = ultrafiltration; O ₃ /BAF = ozone with biologically active filters | |

| Table 2.8 Groundwater Recharge and Extraction Assumptions Wastewater Facilities Plan One Water LA 2040 Plan | | | | |
|---------------------------------------------------------------------------------------------------------------------------------------|-----------------------|---------------------------------------|----------------------------------------------------|-----------------------------------|
| Groundwater Basin | Injection Well Sizing | Extraction Well Sizing ⁽¹⁾ | Additional Wells Needed | Treatment Required ⁽²⁾ |
| San Fernando | 1.8 mgd | 2.7 mgd | Existing extraction wells have sufficient capacity | Nitrate Removal |
| Central | 1.0 mgd | 1.5 mgd | New extraction wells needed | Ion Exchange |
| West Coast | 1.0 mgd | 1.5 mgd | New extraction wells needed | Brackish groundwater desalination |
| Notes: | | | | |
| (1) Extraction well capacity is assumed to be 1.5 times greater than the injection capacity to account for seasonal demand variations | | | | |
| (2) Treatment is based on water quality of the groundwater basins | | | | |

WASTEWATER COLLECTION SYSTEM

3.1 EXISTING COLLECTION SYSTEM

The City owns and operates one of the largest wastewater collection systems in the country, which is responsible for collecting wastewater flows and conveying them to water reclamation plants for treatment. The City's current wastewater collection network consists of over 6,700 miles of public sewers that serving millions of residents, businesses, institutions, and industries throughout the City. This chapter presents the existing collection system, climate risk and resilience assessment and the adaptive CIP. Additional information on the wastewater collection programs is summarized in Appendix B.

3.1.1 Collection System Overview

The City's wastewater service area consists of two distinct drainage basin areas: the HSA and TISA. The HSA covers approximately 553 square miles and serves the majority of the Los Angeles population. In addition, the service area includes 29 non-city agencies that contract with the City for wastewater service as shown on Figure 3.1 (lighter colors correspond to contract agencies). Table 3.1 provides a summary of the "contract agencies."

The TISA is approximately 32 square miles and serves the Los Angeles Harbor area. The two service areas are connected by a strip of land that extends from South Central Los Angeles to the City boundary in the harbor area. The LACSD provides wastewater service to the strip of land that connects the two service areas (approximately 13 square miles).

The wastewater service area is divided into seven tributary areas, or "sewersheds". These include:

- Hyperion-Coastal Sewershed
- Hyperion-Metro Sewershed
- Los Angeles-Glendale Sewershed
- Valley Spring Lane/Forman Avenue (VSL/FA) Sewershed
- Tillman Sewershed
- Terminal Island Sewershed
- Tunnel Sewershed

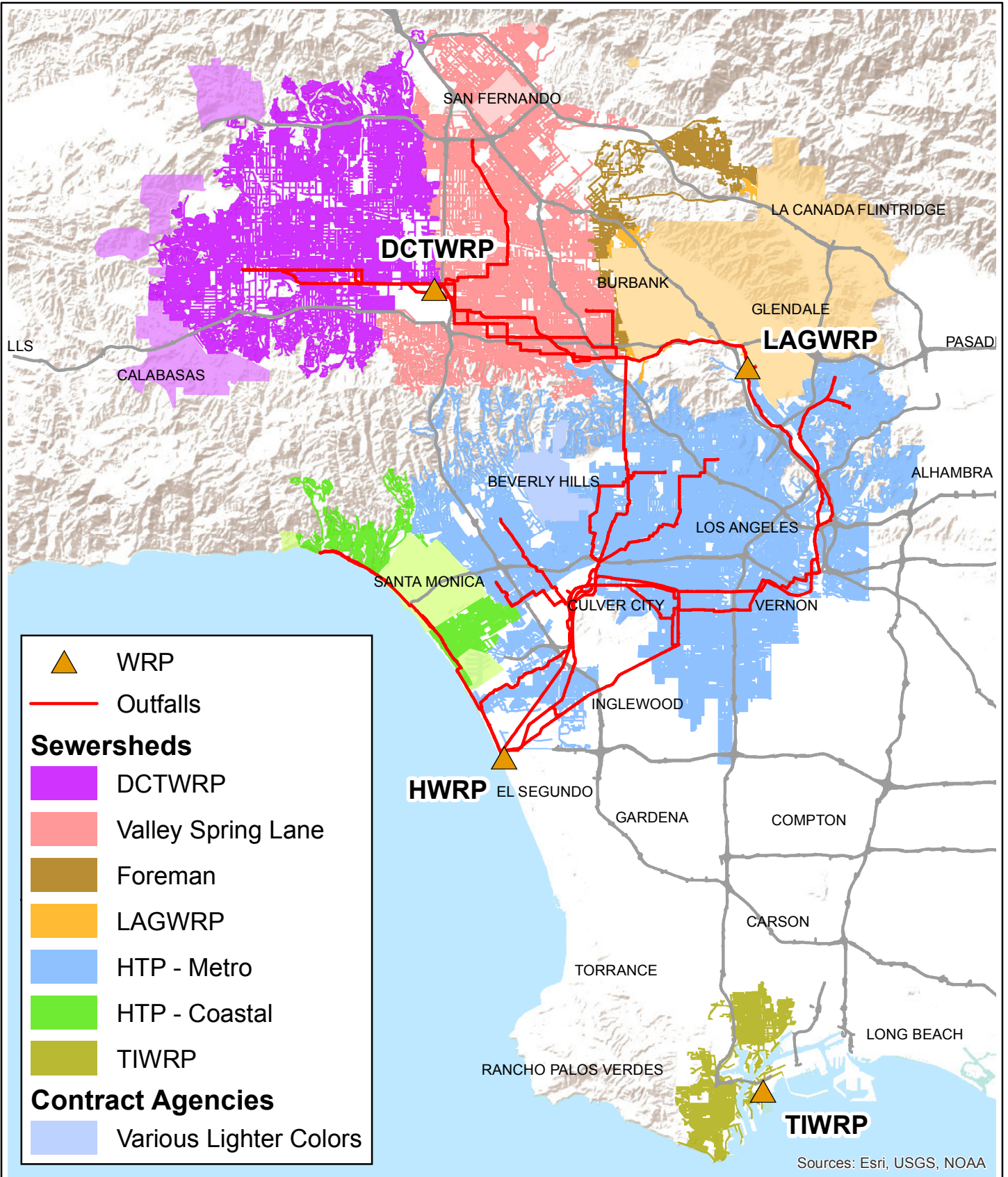
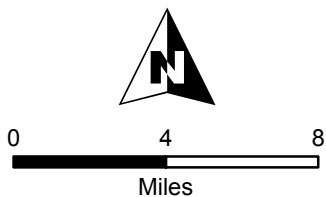

Figure 3.1
City Sewage Service Area
 One Water LA 2040 Plan



| Table 3.1 Contract Agencies Wastewater Facilities Plan One Water LA 2040 Plan | |
|----------------------------------------------------------------------------------------------|--------------------------------------------------------------------------------|
| No. | Contract Agency Name |
| 1 | Aneta Street Tax Zone |
| 2 | Army Reserve Center |
| 3 | Army Reserve Training |
| 4 | Barrington Post Office |
| 5 | City of Beverly Hills |
| 6 | City of Burbank |
| 7 | California National Guard |
| 8 | City of Long Beach |
| 9 | Crescenta Valley Water District |
| 10 | L.A. County Sanitation District #4 (W. Hollywood) |
| 11 | L.A. County Sanitation District #5 (Parts of Inglewood) |
| 12 | L.A. County Sanitation District #09 (Parts of San Pedro) |
| 13 | L.A. County Sanitation District #16 (Parts of Pasadena, S. Pasadena, Alhambra) |
| 14 | L.A. County Sanitation District 27 (Sunset Mesa) |
| 15 | City of Culver City |
| 16 | City of El Segundo |
| 17 | Federal Office Building, West Los Angeles |
| 18 | City of Glendale |
| 19 | Karl Holton Camp |
| 20 | City of La Canada Flintridge |
| 21 | Las Virgenes Municipal Water District |
| 22 | Marina Del Rey Sewer Maintenance District |
| 23 | City of San Fernando |
| 24 | City of Santa Monica |
| 25 | Triunfo County Sanitation District |
| 26 | Universal City |
| 27 | Veterans Affairs (Sawtelle) |
| 28 | Veterans Memorial Park |
| 29 | West Los Angeles Community College |
| Note: (1) Updated from Financial Management Division (FMD) list as of June 2017. | |

3.1.2 HSA Collection System

The HSA wastewater collection system includes more than 6,000 miles of public sewers, 23 pumping plants, and various hydraulic structures such as siphons and diversion structures. Approximately 450 miles are primary sewers, which are 16 inches in diameter or larger, of which about 200 miles are major interceptor and outfall sewers. A major interceptor sewer is one that receives flow from a number of main or trunk sewers and conveys the wastewater to an outfall sewer or water reclamation plant. An outfall sewer is one that receives wastewater from another sewer or reclamation plant and conveys it to a point of final discharge.

The interceptor and outfall sewers serve as the backbone of the wastewater collection system by collecting wastewater from many drainage areas and conveying it to one or more of the HSA's water reclamation plants. This backbone system has largely been aligned according to the natural topography of the area so that most of the system flows by gravity.

3.1.2.1 HSA Major Sewers

The emphasis of this chapter is on the primary (i.e. trunk) and outfall (i.e. interceptor) sewers, which are the major backbone of the City's collection system. The following are the major interceptor and outfall sewers:

1. Additional Valley Outfall Relief Sewer (AVORS)
2. Coastal Interceptor Sewer (CIS)
3. Coastal Interceptor Relief Sewer (CIRS)
4. Central Outfall Sewer (COS)
5. East Central Interceptor Sewer (ECIS)
6. Eagle Rock Interceptor Sewer (ERIS)
7. East Valley Interceptor Sewer (EVIS)
8. East Valley Relief Sewer (EVRS)
9. La Cienega Interceptor Sewer (LCIS)
10. La Cienega-San Fernando Valley Relief Sewer (LCSFVRS)
11. Lower North Outfall Sewer (LNOS)
12. North Central Outfall Sewer (NCOS)
13. North East Interceptor Sewer (NEIS)
14. North Hollywood Interceptor Sewer (NHIS)
15. North Outfall Relief Sewer (NORS)
16. North Outfall Sewer (NOS)
17. Valley Outfall Relief Sewer (VORS)
18. Wilshire-Hollywood Interceptor Sewer (WHIS)
19. West Los Angeles Interceptor Sewer (WLAIS)
20. Westwood Relief Sewer (WRS)

Figure 3.2 shows the primary sewers (i.e. interceptor sewers), outfall sewers (i.e. trunk sewers), pumping plants, major flow diversions, and water reclamation plants within the HSA. Table 3.2 summarizes the general characteristics of these major sewers.

| Table 3.2 Summary of HSA Major Sewers Wastewater Facilities Plan One Water LA 2040 Plan | | | | | |
|--------------------------------------------------------------------------------------------------------|-------------------|-------------------------------------|----------------------------------|----------------------------|----------------|
| Sewer | Length (miles) | Diameter ⁽¹⁾ (inches) | Capacity ⁽²⁾ (cfs) | Material ^(3, 4) | Year Built |
| AVORS | 10.32 | 48 to 96 | 280 | VCP, RCP _{PVC} | Late 1960s |
| CIS | 12.57 | 24 to 72 | 95 | VCP, RCP _{PVC} | 1950s to 1970 |
| CIRS | 0.85 | 24 to 48 | 50 | RCP | 2014 |
| COS | 10.12 | 57, 69, 60 x 73 EL | 100 | BRK, RCP | 1907 |
| ECIS | 12.13 | 132 | 550 | VCP, RCP _{PVC} | 2003 |
| ERIS | 3.70 | 18 to 48 | 50 | VCP, RCP _{PVC} | 2006 |
| EVIS | 9.21 | 36 to 84 | 150 | VCP, RCP _{PVC} | 1987 |
| EVRS | 7.27 | 39 to 51 | 80 | VCP, RCP _{PVC} | 1980s |
| LCIS | 7.50 | 27 to 63 SE | 90 | RCP _{CT} | 1920s |
| LCSFVRS | 11.38 | 48 to 99 SE, 99 x115 box | 330 | RCP _{PVC} | 1955 |
| LNOS | 9.99 | 93 to 126 | 414 | VCP, RCP, CON, BRK | 1922 to 1926 |
| NCOS | 8.27 | 96 to 114 | 400 | RCP, PVC | 1957 |
| NEIS | 5.48 | 96 | 345 | VCP, RCP _{PVC} | 2005 |
| NHIS | 2.60 | 60 to 78 | 220 | VCP, RCP _{PVC} | 2002 |
| NORS | 9.27 | 96 to 150 | 590 | RCP _{PVC} | 1993 |
| NOS | 46.86 | 15 to 102 SE, 147x126 | 414 | VCP, RCP, CON, BRK | 1920s to 1930s |
| VORS | 16.20 | 24 to 66 | 100 | RCP _{PVC} | 1953 to 1962 |
| WHIS | 7.91 | 24 to 69 | 100 | VCP, RCP _{PVC} | 1970s |
| WLAIS | 4.27 | 24 to 60 SE, 48 x 60 box | 100 | Clay, RCP _{CT} | 1950s |
| WRS | 4.39 | 27 to 60 | 130 | VCP, RCP _{PVC} | 1962 |

Notes:
 (1) Non-circular sewers are denoted: elliptical (EL), semi-elliptical (SE), and Burns McDonnell (BM)
 (2) Maximum full flow capacity (d/D = 1.0)
 (3) Material abbreviations: Clay tile (CT), polyvinyl chloride (PVC), reinforced concrete pipe (RCP), vitrified clay pipe (VCP); brick (BRK), unreinforced concrete (CON)
 (4) Subscripts denote liner material
Abbreviation:
 cfs = cubic feet per second

Figure 3.2
HSA Collection System
 One Water LA 2040 Plan



- Flow Diversion
 - P Pumping Plant
 - ▲ WRP
 - Outfalls
 - Primary Sewer
- Sewersheds**
- Various Colors

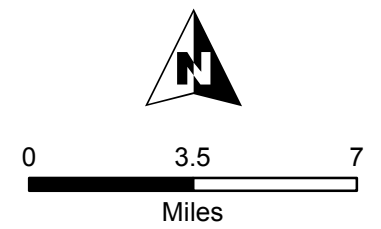
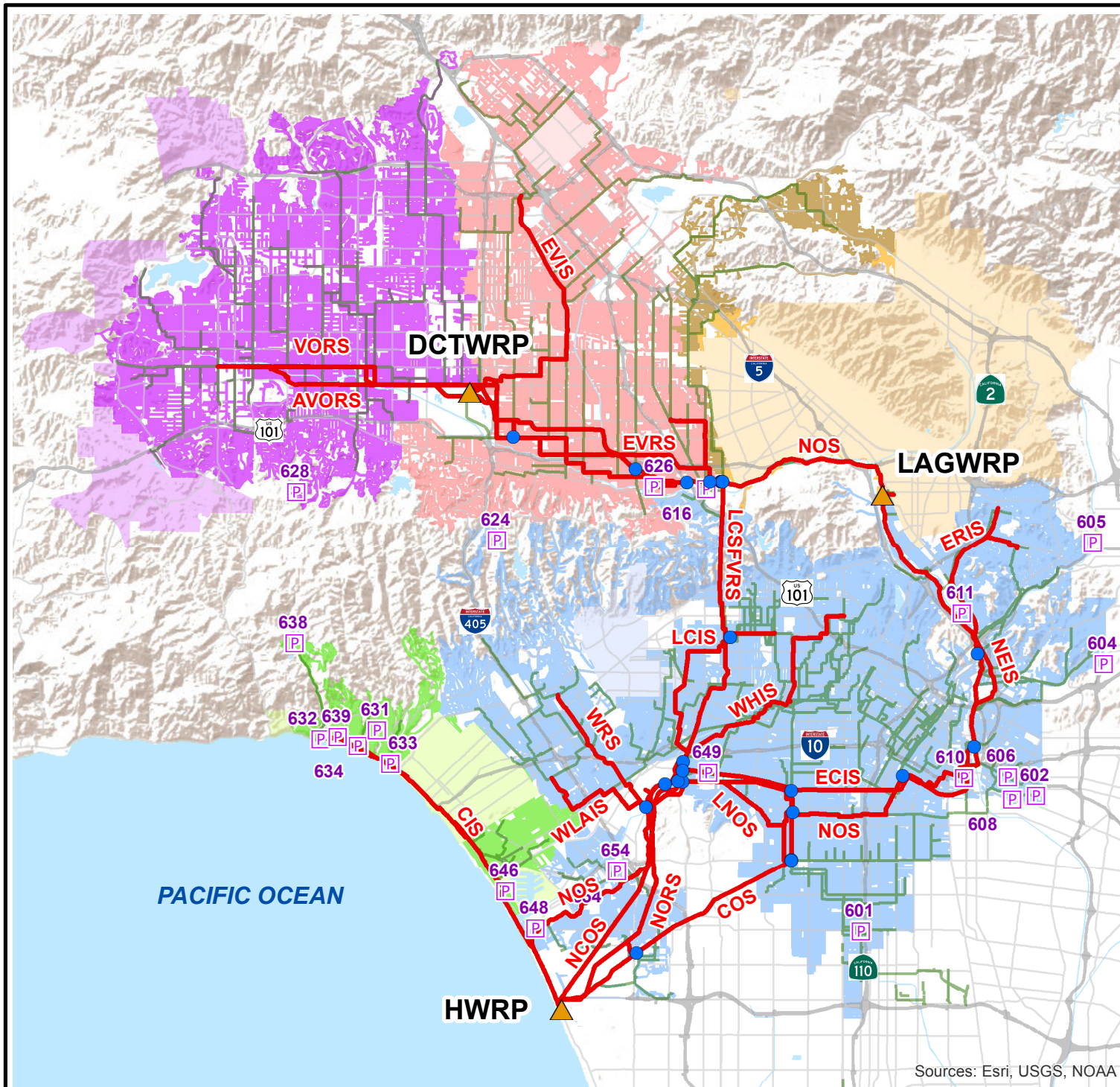

Sources: Esri, USGS, NOAA

3.1.2.2 HSA Major Diversion Structures

Diversion structures are used to divert all or part of the flow from one sewer to another and grant ease of flow between pipes. All diversion structures are passively operated, meaning physical settings remain fixed over time until manually readjusted. There are approximately 19 major outfall diversion structures in the HSA wastewater collection system. Table 3.3 summarizes the major outfall diversion structures.

| Table 3.3 Summary of HSA Major Diversion Structures Wastewater Facilities Plan One Water LA 2040 Plan | | |
|----------------------------------------------------------------------------------------------------------------------|-------------|-----------------------|
| Name of Diversion Structure | MH # | Sewers |
| Victory and Haskell | 44208151 | VORS, EVIS |
| Magnolia and Kester | 42916066 | AVORS, EVRS, NOS |
| Acama and Vineland | 44306172 | VORS, NOS |
| Valley Spring Ln and Strohm | 44307222 | EVRS |
| Valley Spring Ln and Forman Av | 44307169 | NOS, LCSFVRS |
| | 44307225 | NOS, LCSFVRS |
| | 44307204 | NOS, LCSFVRS |
| | 44307203 | NOS, LCSFVRS |
| | 44307202 | EVRS, NOS, LCSFVRS |
| Humboldt Junction | 49509121 | NOS, NEIS |
| Mission and Jesse | 51513132 | NOS, ECIS |
| Trinity and 23rd St | 53702211 | NOS, ECIS |
| Rodeo Rd and Arlington | 53606216 | COS, NOS |
| Van Ness and 41st | 53610219 | NOS, COS |
| Slauson and Van Ness | 55802350 | COS, NOS |
| | 55802198 | |
| Clinton and Poinsettia | 49208166 | LCIS, LCSFVRS |
| Fairfax and Blackwelder | 51814166 | LCIS, LCSFVRS |
| La Cienega and Jefferson | 53502134 | LCSFVRS, ECIS |
| Rodeo Rd and La Cienega | 53502121 | NOS, LCSFVRS |
| NORS Diversion Structure #1 | 53502155 | NCOS, NORS |
| NORS Diversion Structure #2 | 53505018 | LNOS, NORS |
| NORS Diversion Structure #3 | 53509013 | LNOS, NORS, WRS/WLAIS |
| NORS Diversion Structure #4 | 56308120 | COS, NORS |

3.1.2.3 HSA Pumping Plants

There are 23 pumping plants in the HSA wastewater collection system. The pumping plant capacities range from 20 gallons per minute (gpm) to 45,000 gpm. Table 3.4 lists the pumping plant numbers, names, and capacities.

| Plant No. | Name | Capacity (gpm) |
|------------------|-------------------------|-----------------------|
| 601 | Manchester | 14,000 |
| 602 | Union Pacific | 4,600 |
| 604 | Highbury | 2,250 |
| 605 | San Pasqual | 30 |
| 606 | Dacotah | 10,000 |
| 608 | Washington & Industrial | 100 |
| 610 | 11th & Santa Fe | 2,000 |
| 611 | Riverdale | N/A ⁽¹⁾ |
| 616 | Cahuenga | 1,600 |
| 624 | Roscomare | 500 |
| 626 | Riverdale | 80 |
| 628 | Corbin | 400 |
| 631 | Hamden Place | 110 |
| 632 | Sunset | 10,000 |
| 633 | Chautauqua | 300 |
| 634 | Temescal | 4,500 |
| 638 | Palisades | 600 |
| 639 | North Pulga | 3,000 |
| 646 | Venice Pumping Plant | 45,000 |
| 648 | Thompson | 700 |
| 649 | Jefferson | 190 |
| 654 | Ballona Creek | 18,000 |
| 659 | NORS | 20 |

Note:
 (1) No pump, bladder storage pumped out with tanker truck.
Abbreviation:
 N/A = not applicable

3.1.3 TISA Collection System

TISA includes the communities of Wilmington and San Pedro, and also portions of Terminal Island within the Port of Los Angeles. The TISA consists of 240 miles of sewer and 20 pumping plants. The TISA is located farther south from the larger HSA, making it

geographically isolated from the greater Los Angeles Basin and therefore requiring a separate wastewater collection, treatment, and disposal system. With the exception of one pump station, all of the wastewater collected in the TISA is pumped to TIWRP through several pump stations and force mains. Though some of the sewer systems in the TISA are known as interceptor sewers, named after the respective force main, they are not considered part of the City's interceptor/outfall sewer system because of the smaller drainage areas they serve.

3.1.3.1 TISA Pumping Plants







There are 19 pumping plants in the TISA wastewater collection system. The pumping plant capacities range from 100 gpm to 18,000 gpm. Six pumping plants (Nos. 666, 669, 671, 676, 677, and 691) discharge directly to the TIWRP headworks. The remaining pumping plants are tributary to one of the six pumping plants. Table 3.5 lists the pumping plant numbers, names, and capacities. Pumping plant No. 674 discharges into the Los Angeles County Sanitation's (LACSD) treatment plant Joint Water Pollution Control Plant (JWPCP) and is not listed in Table 3.5.

| Table 3.5 TISA Pumping Plants Wastewater Facilities Plan One Water LA 2040 Plan | | |
|------------------------------------------------------------------------------------------------|-------------------|-----------------------|
| Plant No. | Name | Capacity (gpm) |
| 666 | Fries Ave. | 7,400 |
| 668 | Henry Ford | 6,800 |
| 669 | Harris Place | 1,600 |
| 671 | Terminal Way | 10,000 |
| 672 | Murdock & "I" | 1,100 |
| 674 | 190th & Vermont | 2,800 |
| 675 | P.C.H. & Figueroa | 1,200 |
| 676 | McFarland | 8,000 |
| 677 | Hawaiian & "B" | 5,800 |
| 680 | 22nd & Signal | 100 |
| 681 | Ports 'O' Call | 300 |
| 683 | 22nd Street | 900 |
| 684 | Miner | 500 |
| 685 | Signal | 200 |
| 686 | Nissan Way | 1,700 |
| 688 | South Neptune | 700 |
| 689 | Seaside | 1,000 |
| 690 | Anchorage | 520 |
| 691 | San Pedro | 18,000 |

Figure 3.3 shows the secondary sewers (i.e. collector sewers), primary sewers, pumping plants, and forcemains, within TISA.

Figure 3.3
TISA Collection
System
 One Water LA 2040 Plan



-  Pumping Plant
-  WRP
-  Force Main
-  Primary Sewer
-  Secondary Sewer
-  Street
-  Sewershed

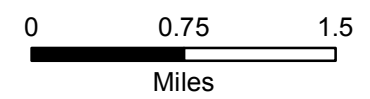
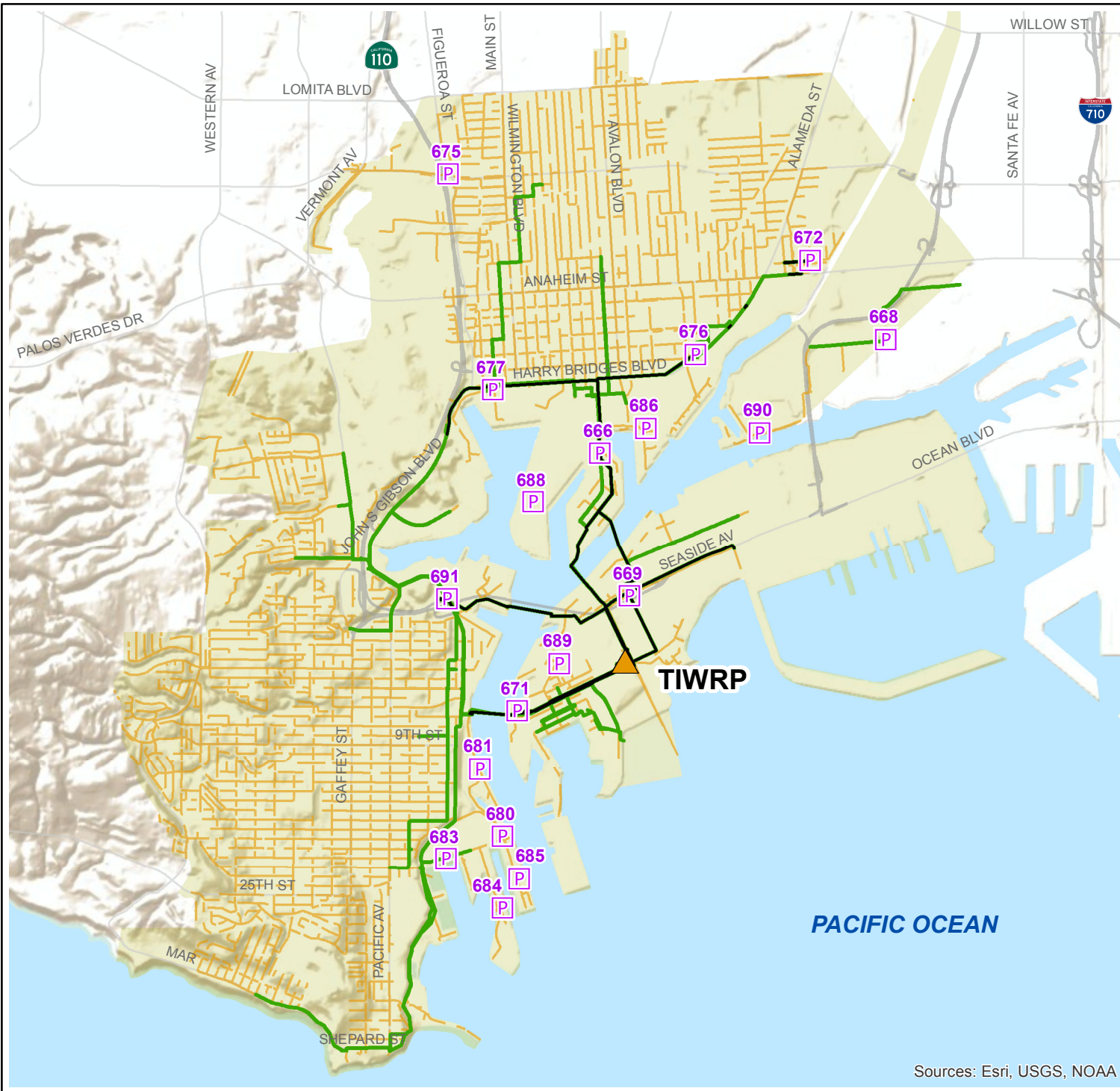

Sources: Esri, USGS, NOAA

3.1.4 Low Flow Diversion Structures

In order to enhance the water quality of the City's watersheds and mitigate pollutants found in stormwater, the City operates and maintains 21 low flow diversion (LFD) facilities that take dry-weather runoff in the storm drain and diverts it to the sanitary sewer system or treats it onsite for local water reuse applications. LFDs may also divert the first flush of wet-weather events and/or store stormwater flows for later reuse. Typically, dry-weather runoff contains low volumes of water, which leads to higher concentrations of pollutants due to less dilution of contaminants. By diverting runoff to the sanitary sewer, the stormwater undergoes conventional wastewater treatment that removes many of the pollutants. Treated runoff and wastewater is then either reused or discharged back into the City's water bodies meeting all NPDES permit requirements. The City-owned LFD facilities are shown in Table 3.6. The pumping capacity reflects wet weather diversion and equalization.

| Table 3.6 City-Owned Low Flow Diversions Wastewater Facilities Plan One Water LA 2040 Plan | | | |
|-----------------------------------------------------------------------------------------------------------|--------------|--------------------------------|----------------------------------------------------------------|
| No. | LFD # | LFD Name | Pumping Capacity to Sanitary Sewer System (gpm) |
| 1 | 614 | Tuxford (LFD) | 180 |
| 2 | 615 | Sun Valley Park | 80 |
| 3 | 647 | Kinney Circle (LFD) | 500 |
| 4 | 701 | South LA Wetlands | Treated Onsite For Local Reuse |
| 5 | 703 | Echo Park | Treated Onsite For Local Reuse |
| 6 | 705 | Garvanza | Treated Onsite For Local Reuse |
| 7 | 710 | 8th/Enterprise | 700 |
| 8 | 711 | Downtown | Conveyed by Gravity |
| 9 | 730 | Palisades Park | 1,480 |
| 10 | 732 | Marquez Canyon | 300 |
| 11 | 733 | Santa Monica (New) | 10,000 |
| 12 | 734 | Temescal | 3,500 |
| 13 | 735 | Santa Monica Canyon (Inactive) | 3,500 |
| 14 | 736 | Temescal Canyon | 3,500 |
| 15 | 739 | Bay Club Drive | 340 |
| 16 | 740 | Westside Park | Treated Onsite For Local Reuse |
| 17 | 741 | Mar Vista | 4,800 |
| 18 | 742 | Penmar | 2,700 |
| 19 | 747 | Thornton | 1,500 |
| 20 | 748 | Westminster Dog Park | Treated Onsite For Local Water Reuse |
| 21 | 750 | Imperial Hwy | 644 |

The City's sanitary sewer system also receives dry-weather runoff from fourteen LFDs that are owned and operated by contract agencies. The non-City owned LFDs are shown in Table 3.7.

| No. | LFD Name | Contract Agency |
|------------|--------------------------------------------|------------------------|
| 1 | Ashland Avenue | L.A. County |
| 2 | Electric Avenue Pump Plant (Brooks Avenue) | L.A. County |
| 3 | Parker Mesa/Castlerock | L.A. County |
| 4 | Westchester | L.A. County |
| 5 | Pulga Canyon | L.A. County |
| 6 | Santa Ynez | L.A. County |
| 7 | Boone Olive PP | L.A. County |
| 8 | Marina Del Rey (Oxford Basin) | L.A. County |
| 9 | Pershing Drive, Line C | L.A. County |
| 10 | Playa del Rey | L.A. County |
| 11 | Rose Avenue | L.A. County |
| 12 | Washington Blvd | L.A. County |
| 13 | Montana Avenue | City of Santa Monica |
| 14 | Wilshire Boulevard | City of Santa Monica |

Table 3.7 shows that the majority of non-city owned LFDs are owned and operated by L.A. County, with only two non-city owned LFDs operated by the City of Santa Monica.

3.2 PLANNED COLLECTION SYSTEM PROJECTS

The City implements projects to accommodate changing collection system flows and aging infrastructure. When constructed, these projects will improve collection system operations and maximize opportunities for water reuse. The planned collection system projects are:

- LAGWRP Primary Effluent Equalization Storage
- North Outfall Sewer Rehabilitation
- Venice Pumping Plant Dual Force Main
- Venice Auxiliary Pumping Plant

3.2.1 LAGWRP Primary Effluent Equalization Storage

The LAGWRP Primary Effluent Equalization (EQ) Storage project will construct one 2.5-million gallon (MG) primary effluent storage tank to perform flow equalization at LAGWRP, two primary clarifiers (with process equipment), three aeration tanks (one with process equipment installed for biological nutrient removal), two final clarifiers (with process equipment), two 24-inch discharge piping to discharge stored diurnal flow and/or wet-weather flow from 2.5 MG EQ to Headworks or in-plant sewer respectively, and equipment and controls for integration with existing systems. This project is dual purpose and will provide upstream relief required for the collection system triggered by cancellation of North East Interceptor Sewer (NEIS) 2A and equalization for diurnal flow deemed required for providing consistent flow and loading to LAGWRP processes to maintain its rated capacity of 20 mgd average-dry-weather flow for optimum treatment and to provide operational flexibility.

3.2.1 North Outfall Sewer Rehabilitation

The NOS is the longest sewer outfall in the City's wastewater collection system (approximately 59 miles long) and is the backbone of the City's sewer system. The majority of the NOS was built in the 1920s and 1930s, and generally constructed of unreinforced concrete lined with ceramic tiles, reinforced concrete lined with clay tiles, or vitrified clay pipe, in both circular and semi-elliptical shapes

The NOS is generally categorized into three (3) portions: the lower NOS, Maze, and upper NOS. Between the 1990s and 2015, the City rehabilitated all 19.4 miles of the lower and Maze portions of the NOS. In 2012, the City conducted another major effort to assess the physical condition of the NOS between the Vann Ness / 41st and the Valley Spring Lane / Foreman diversion near the community of Toluca Lake. Utilizing historical closed circuit television (CCTV), a 2012 study broke up the alignment into 26 units and prioritized the rehabilitation efforts based on an algorithm that included CCTV ranks and percent of uninspected reaches. Each unit measured nearly one (1) mile in length and the cumulative total was approximately 23.5 miles. Of the 26 units, 19 units were recommended to be rehabilitated, which was later consolidated into 18 rehabilitation projects.

Due to the accelerated degradation of the NOS, the City is expediting the rehabilitation of the existing 18 NOS rehabilitation projects, as well as assessing and rehabilitating the remaining 16 miles upstream of VSL/FA using CCTV and laser and sonar profiling. The cost of rehabbing each unit, roughly one (1) mile each, ranges between \$10 and \$20 million (2017 dollars).

3.2.2 Venice Pumping Plant Dual Force Main

This project constructs approximately 10,800 feet of a new 54-inch-diameter force main sewer. The proposed force main starts from the existing Venice Pumping Plant (VPP) at 140 Hurricane Street in the community of Venice and terminates at an existing junction

structure on Vista del Mar near Waterview Street. The project also replaces the existing pump discharge manifold on Hurricane Street.

The VPP's existing 48-inch diameter force main sewer was built in 1958; it conveys wastewater flow to HWRP. The current maximum capacity of 44,000 gpm was briefly exceeded by the peak wet weather flow (PWWF) during major storms. When that occurred, the sewage rose in the equalization wet well, which could potentially result in sewage overflow into the Grand Canal if storage capacity was exceeded. During heavy storms, such as those that occurred in the winters of 1994-95 and 2004-05, the excess wastewater at the plant came within minutes of overflowing into the Grand Canal.

The project's intent is to construct a second force main sewer to operate in tandem with the existing force main sewer for the purpose of fulfilling the three key goals described below:

- The new force main will operate as a parallel system in conjunction with the existing 48-inch force main to meet the existing PWWF demands experienced at VPP.
- Add operational flexibility and reliability.
- Allow isolation of either force main during low flow conditions to perform necessary cleaning and maintenance.

The total cost of the project is estimated at \$118,770,000 (2017 dollars). Construction of the project began early-2017 and scheduled to be completed mid-2020.

3.2.3 Venice Auxiliary Pumping Plant

The City currently owns and operates the VPP near the Ballona Lagoon and Venice Beach. The pumping plant is the City's largest pumping plant and is considered a critical facility to convey sewage from the tributary area. Heavy storms during the 1994-1995 and 2004-2005 resulted in periods of heavy rainfall, infiltrated stormwater, and high sewage flows, which put the VPP within minutes of overflowing into the Grand Canal. One or more pumps at VPP are occasionally out of service for extended periods which would put the VPP at serious risk during peak wet weather flow conditions.

The main goals of the Venice Auxiliary Pumping Plant (VAPP) Project are:

- Provide a new auxiliary pumping plant to supplement the existing VPP.
- Will house three pumps of similar capacity as the existing pumps at VPP.
- Provide a new electrical building with lavatory, control and server rooms, electrical/mechanical rooms, and a generator room.
- Provide a 24 kilowatt (kW) Tier 4 Final Certified Emissions diesel generator.
- Provide site security for both VPP and VAPP.
- Provide VPP and VAPP control capabilities from both VPP and VAPP.

The total cost of the project is estimated at \$27,970,000 (2017 dollars). Construction of the project is scheduled to start in mid-2018 and completed late-2020.

3.3 CONCEPTUAL CAPITAL IMPROVEMENT PROJECTS

In addition to the planned collection system projects, the City has also defined two conceptual capital improvement projects:

- East-West Valley Interceptor Sewer (EWVIS)
- San Fernando Relief Sewer

3.3.1 East-West Valley Interceptor Sewer (EWVIS)

In response to the Mayor's ED#5 (Emergency Drought Response) and #7 (Sustainable City Plan), the City of Los Angeles is committed to maximizing water reuse from its water reclamation facilities, including DCTWRP. DCTWRP was originally constructed in 1984 to treat and recycle up to 40 mgd of wastewater. DCTWRP was later expanded in 1991 to 80 mgd, by adding a second 40 mgd treatment train. However, due to water conservation, incoming flows are insufficient to operate the second phase of the facility and thus operates at 40 mgd. The purpose of the project is to investigate the feasibility of diverting additional wastewater from the HWRP service area to the DCTWRP service area. The increased flow to DCTWRP would facilitate increased recycled water production. An initial feasibility study investigated various sewer alignments and pumping plant configurations to convey flows from the North Hollywood Sewer Basin within the Valley Spring Lane sewershed to DCTWRP.

3.3.2 San Fernando Relief Sewer

The San Fernando Relief Sewer project would construct approximately 4 miles of 48-inch sewer from the termination of NEIS to NOS, just upstream of LAGWRP, to provide redundancy to the NOS. The project was developed as a result of the North Outfall Sewer Hydraulic Condition Assessment (2015). Previous studies have shown that the NOS, a 42- to 48-inch sewer, requires hydraulic relief within the 50-year planning window. In order to relieve NOS and LCSFVRS, it was recommended to tunnel nearly 12 miles of 96-inch sewer from Glassell Park to North Hollywood—a major undertaking. However, due to water conservation and optimization of the existing sewer infrastructure, the comprehensive study concluded that only the NOS required relief, which can be done at a fraction of the cost by constructing flow equalization storage at LAGWRP to attenuate peak flows. The study further recommended to construct the San Fernando Relief Sewer to provide redundancy to the system in the event LAGWRP is shut down (e.g. due to process upset, power outage, or maintenance). The relief sewer would provide sufficient capacity to facilitate an LAGWRP shutdown during a significant storm event. The cost of the project is estimated at \$99,000,000 (2015 dollars). The project completion schedule is to be determined and is currently being advertised to conduct a feasibility study.

3.4 CLIMATE RISK AND RESILIENCE ASSESSMENT

Climate change is projected to impact the City's wastewater and stormwater systems in a variety of ways. The wastewater systems consist of sewer systems, sewage pumping facilities, wastewater treatment facilities and water reclamation facilities. Changes in temperature, precipitation, and sea levels will affect the physical plant and operational vulnerabilities of these facilities and operations.

A climate risk and resilience assessment was performed consisting of scenario development, screening analyses, site visits, risk analyses, and adaptation planning concurrent with meetings with LASAN staff. Current and potential future climate conditions were incorporated into the assessment and development of recommendations. Subsequently, practical improvements for the collection system were identified to mitigate these risks.

The City owns and operates 77 wastewater and stormwater pumping plants, and LFD. Each of these facilities was screened and assessed for existing and potential future climate hazards and the associated risks. Of the wastewater and stormwater pumping plants, and LFD, 33 were determined to have greater than minimal identified threats. The estimated resilience improvement cost for wastewater pumping plants is \$12,966,000, for stormwater pumping plants is \$1,860,000, for LFDs is \$380,000, and \$1,570,000 for LFD/stormwater facilities (647 Kinney Circle and LA Zoo). The overall estimated resilience improvement cost for pumping plants and LFDs is \$16,806,000. A detailed description of the climate risk assessment of and listing of facilities for the collection system is included in Chapter 10.

3.5 COLLECTION SYSTEM ADAPTIVE CIP

A variety of wastewater collection system programs are used to identify necessary capital improvement projects for continued operations. Details of these programs are summarized in Appendix B. These projects and the associated adaptive collection system capital improvement plan is discussed further in Chapter 11. The purpose of this section is to summarize the capital improvement projects identified for the collection system. The sources used to develop the summary CIP include the Los Angeles Bureau of Engineering (LABOE) Uniform Project Reporting System (UPRS), LASAN Wastewater Capital Improvement Plan (WCIP), LADWP 2015 UWMP, and concept options developed as part of the One Water LA 2040 Plan.

The development of the Collection System Adaptive CIP compiles the projects previously identified in the WCIP developed by the City. The costs for these projects are presented by category and phase, defined in Table 3.8. Project costs are then summarized and escalated based upon implementation schedule to provide a baseline CIP for the Collection System. The CIP for Collection System represents one component of the overall WWFP Adaptive CIP. The details for cost estimating methodology are summarized in Chapter 11.

| Table 3.8 CIP Terms and Definition Wastewater Facilities Plan One Water LA 2040 Plan | | |
|------------------------------------------------------------------------------------------------------------------------------------------------------------------------------------------------------------------------------------|------------------------------------------------|-------------------------------------------------------------------------------------------------------------------------------------------------------------------------------------------------------------------------------------------------------|
| Group | Term | Definition |
| Category | Capital Project from WCIP | These projects were previously identified in the WCIP. These projects include new construction, expansion, or renovation that helps maintain or improve a City facility or infrastructure that may be funded by the Capital Budget. |
| | Replacement and Rehabilitation (R&R) from WCIP | These are projects identified in the WCIP. These projects are needed for the continued operation of the facility in its present form. |
| | Climate Resiliency Projects ⁽¹⁾ | These are projects developed as part of the Plan and identified in Volume 6 Climate Risk and Resilience Assessment for Wastewater and Stormwater Infrastructure. These projects are needed to adapt to environmental conditions due to climate change |
| Phase ⁽²⁾ | Near-Term | Projects that are planned to be constructed between 2018 to 2020 |
| | Mid-Term | Projects that are planned to be constructed between 2021 and 2030 |
| | Long-Term | Projects that are planned to be constructed between 2031 and 2040 |
| <p><u>Note:</u></p> <p>(1) Climate resiliency projects were identified based on the analysis described in Volume 6.</p> <p>(2) The phases were determined by LASAN and LADWP management for all projects included in the Plan.</p> | | |

3.5.1 Collection System Estimated CIP

The Estimated CIP is based on the WCIP plus the climate risk analysis, as shown in Table 3.9 and Figure 3.4. The details of the summary table can be found in Appendix H.

| Table 3.9 Collection System Estimated CIP Wastewater Facilities Plan One Water LA 2040 Plan | | | |
|----------------------------------------------------------------------------------------------------|-----------------------------|--------------------------------|--------------------------------|
| | Category | Total (\$2017) Millions | Total (\$2017) Millions |
| Near-Term | Capital Project from WCIP | \$238 | \$641 |
| | R&R from WCIP | \$401 | |
| | Climate Resiliency Projects | \$2 | |
| Mid-Term | Capital Project from WCIP | \$21 | \$78 |
| | R&R from WCIP | \$56 | |
| | Climate Resiliency Projects | \$2 | |
| Long-Term | Capital Project from WCIP | \$0 | \$22 |
| | R&R from WCIP | \$11 | |
| | Climate Resiliency Projects | \$11 | |
| | | Total | \$741 |

Table 3.9 shows that the majority of the Estimated CIP costs are anticipated to occur in the near-term phase. The near-term phase uses the projects identified in the WCIP and thus have a greater definition. The same information is shown graphically on Figure 3.4.

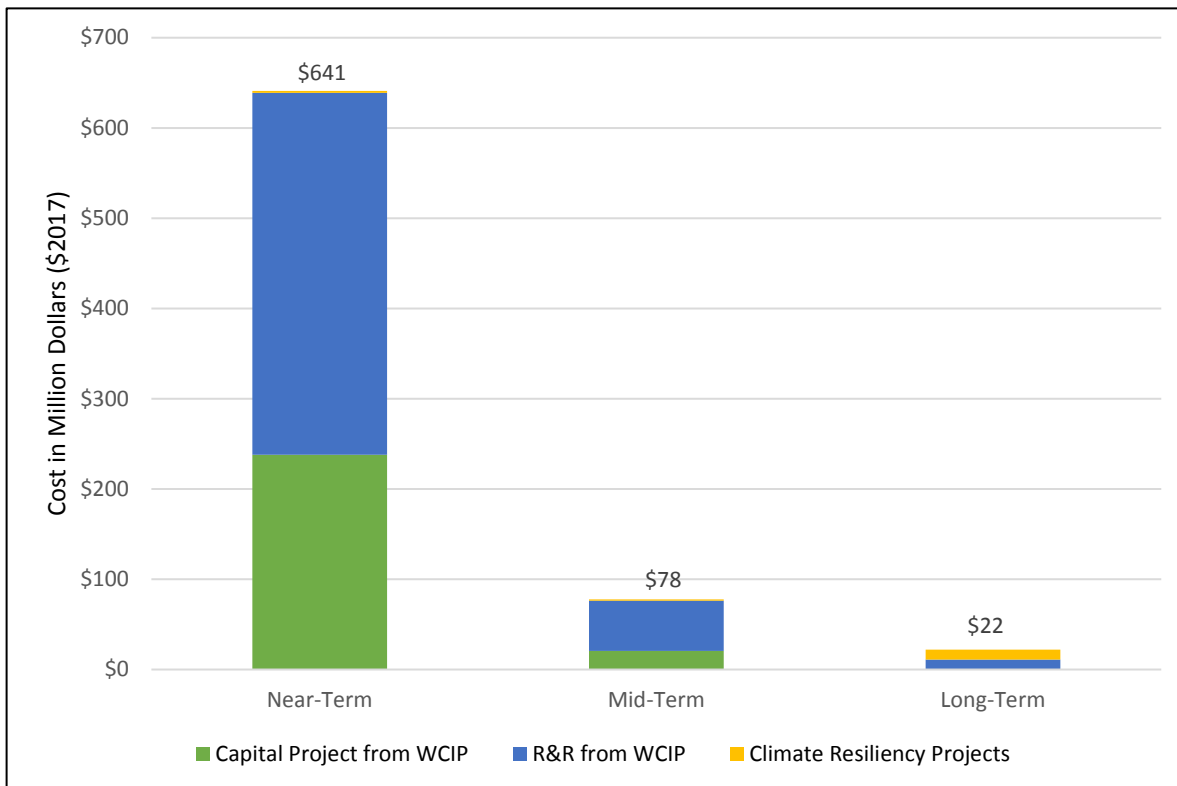

Figure 3.4 Summary of Collection System Projected CIP Costs

The CIP for the collection system earmarks a large amount in the near-term, with less in the mid-term and long-term, as seen in Table 3.9 and on Figure 3.4. Replacement and rehabilitation projects and their associated costs, are more specifically identified for the near- and mid-term phases and thus, the capital costs for this category are more defined in these two phases with greater specificity than in the long-term. The Estimated CIP costs summarized in Table 3.9 translates to an average cost of approximately \$214 million per year from 2018 to 2020, \$7.8 million per year from 2021 to 2030, and \$2.2 million per year from 2031 to 2040.

Figure 3.5 presents the same Estimated CIP information as Table 3.9 but depicts the total value by percent allocated to each category. The replacement and rehabilitation category is the largest of the three, as the City's collection system is continually assessed and repaired.

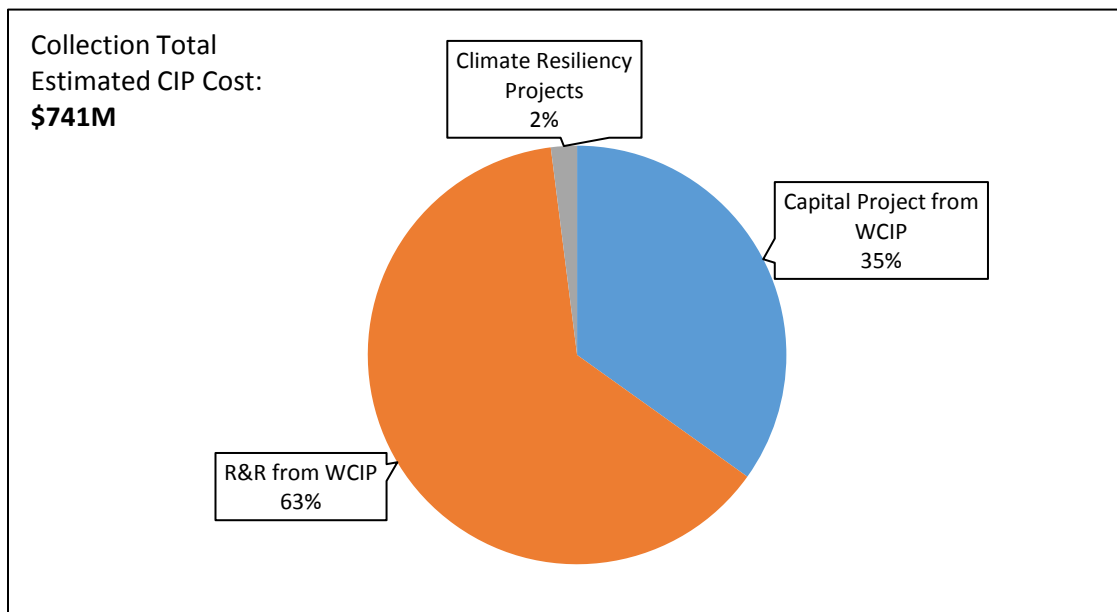

Figure 3.5 Collection System Projected CIP Costs by Category in 2017 Dollars

3.5.2 Collection System Adaptive CIP Net Present Worth Summary

The values for each of the projects were developed in 2017 dollars. Recognizing that the City will not implement all projects immediately, the projects have been divided into phases. The costs for the projects that are scheduled to be implemented in the near, mid and long-term were adjusted to account for inflation and escalated at a rate of 3 percent per year. To allow a comparison of costs between phases, the projected costs were brought back to a present value using a discount rate of 2 percent per year. Discounting the escalated costs yields a net present value and reflects the future values in 2017 dollars.

The net present worth of the Collection System Adaptive CIP is \$764 million. For the 2040 planning horizon, this total value equates to \$33 million on an annual basis. Figure 3.6 shows how the time value of money impacts each of the phases of the CIP.

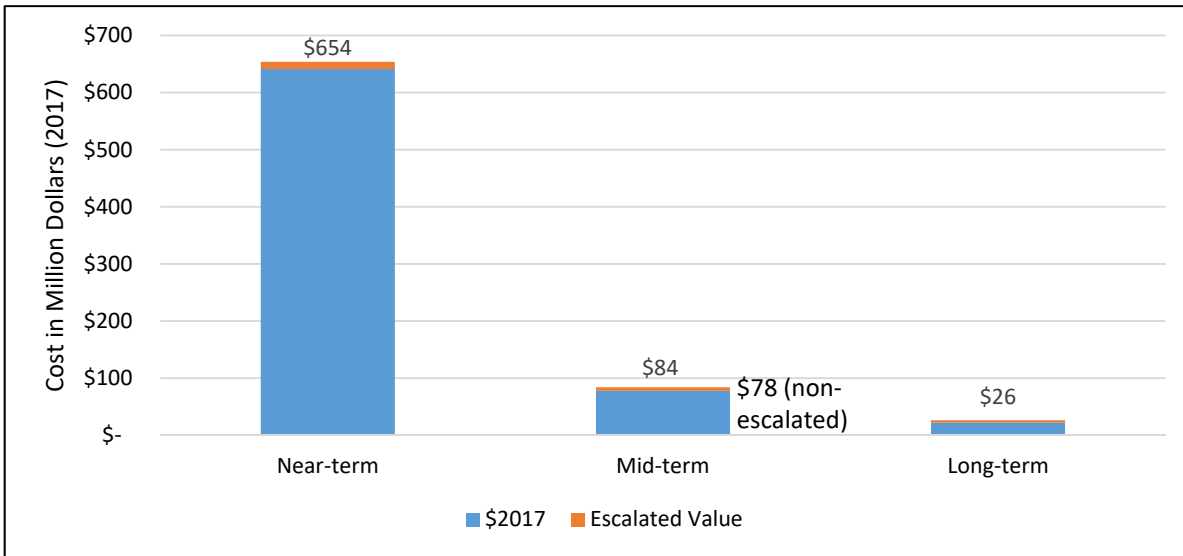

Figure 3.6 Present Worth Comparison: Escalated versus Non Escalated CIP

The near-term phase has the greatest impact on the CIP, as the projects are more clearly defined in this phase.

HYPERION WATER RECLAMATION PLANT

The HWRP has been in operation since the 1890s, and is the City's oldest and largest wastewater treatment facility. The plant is located on a 144-acre site near the Los Angeles World Airport (LAWA) and Dockweiler State Beach. The plant is bounded by Imperial Highway on the north, Vista Del Mar on the west, Scattergood Power Plant on the south, and the City of El Segundo on the east. The location and an overview of the entire plant is shown on Figure 4.1.

The original plant provided minimal treatment before discharge into Santa Monica Bay, but was upgraded in 1950 to provide advanced primary/partial secondary treatment. It was upgraded again in 1998 to provide full secondary treatment and began a contractual partnership with West Basin Municipal Water District (WBMWD) by sending a portion of the HWRP effluent to WBMWD's Edward C. Little Water Recycling Facility (ECLWRF), which provides advanced treatment to produce various qualities of recycled water to customers in the south bay and west Los Angeles area and parts of Los Angeles Harbor.

The HWRP is located within the HSA and treats wastewater from a tributary area of approximately 515 square miles. The plant serves many communities including Baldwin Hills, Bel Air-Beverly Crest, Beverly Hills, Brentwood, Boyle Heights, Central City North, Central City, Central Los Angeles, Culver City, Echo Park, Hollywood, Marina Del Rey, Northeast Los Angeles, Pacific Palisades, Palms, Playa del Rey, Sherman Oaks, Santa Monica, Silverlake, Southeast Los Angeles, Studio City, Universal City, West Adams, Westchester, Westlake, West Los Angeles, Westwood, and Wilshire. In addition to serving the communities listed above, HWRP receives and treats process residual flows from the DCTWRP, the LAGWRP, the Burbank Water Reclamation Plant (BWRP), the Los Angeles Zoo Treatment Facility (LAZTF) and wastewater flows exceeding the current capability of these facilities. The areas tributary to the HWRP are shown on Figure 4.2.

This chapter describes the Existing Treatment Process Description, In-Progress Projects, Future System Needs Evaluation, Climate Risk and Resilience Analysis, and Adaptive Capital Improvement Plan for HWRP.

4.1 EXISTING TREATMENT PROCESS DESCRIPTION

This section outlines existing systems at HWRP, documents plant upgrades, and is organized as follows:

- General plant overview
- Current flows and loadings
- Process descriptions
- Recent and ongoing plant upgrades

Understanding existing facilities is critical to the assessment of future potential projects to improve performance and enhance water reuse.

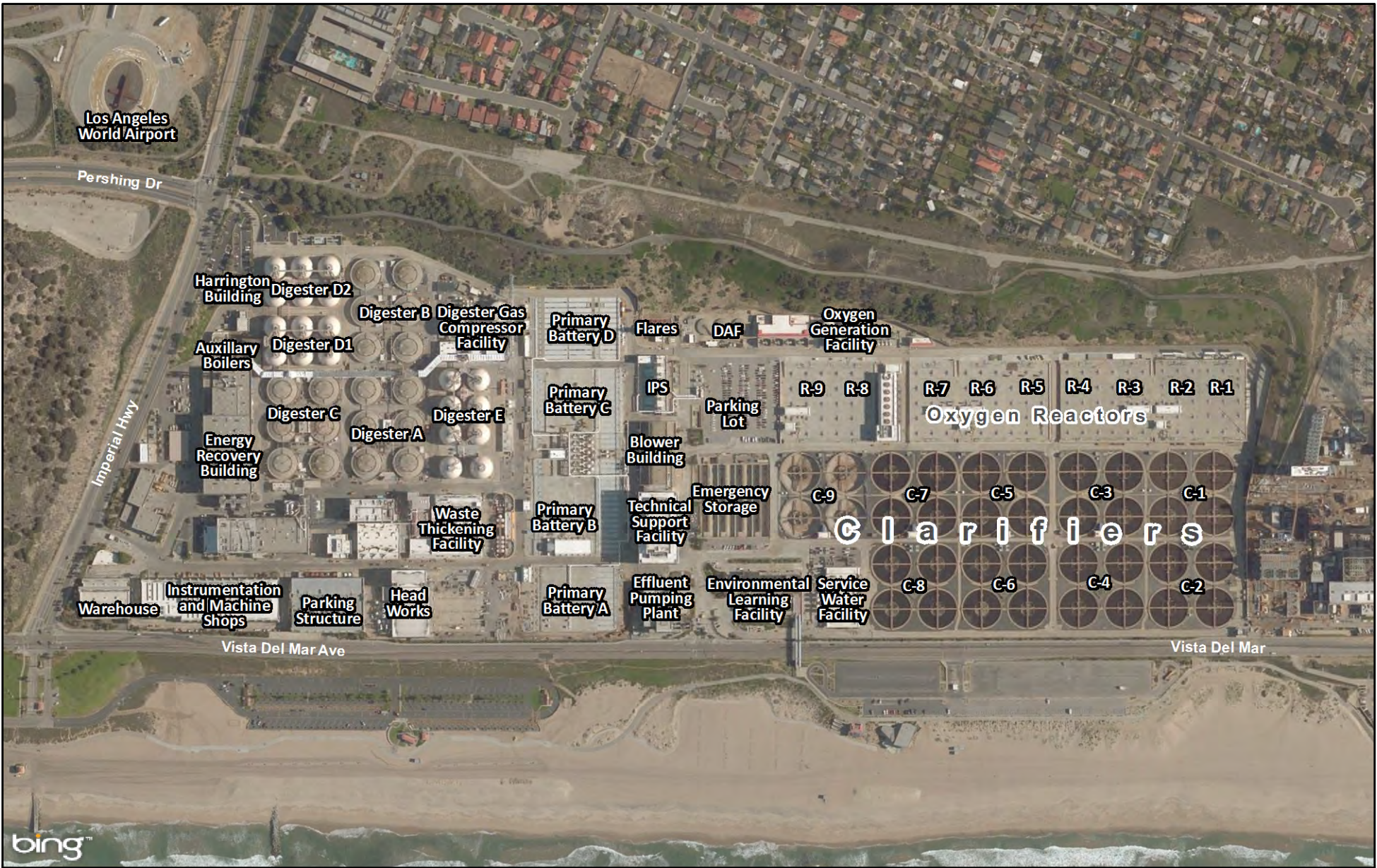

Document Path: \\usinv1s01\GIS\GIS_Jobs\City_LA_BOS_MXD\OneWater_LA2040Plan\General\HWRP_ProcessLocations.mxd

Figure 4.1
HWRP Aerial Overview
 One Water LA 2040 Plan

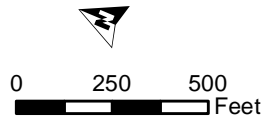

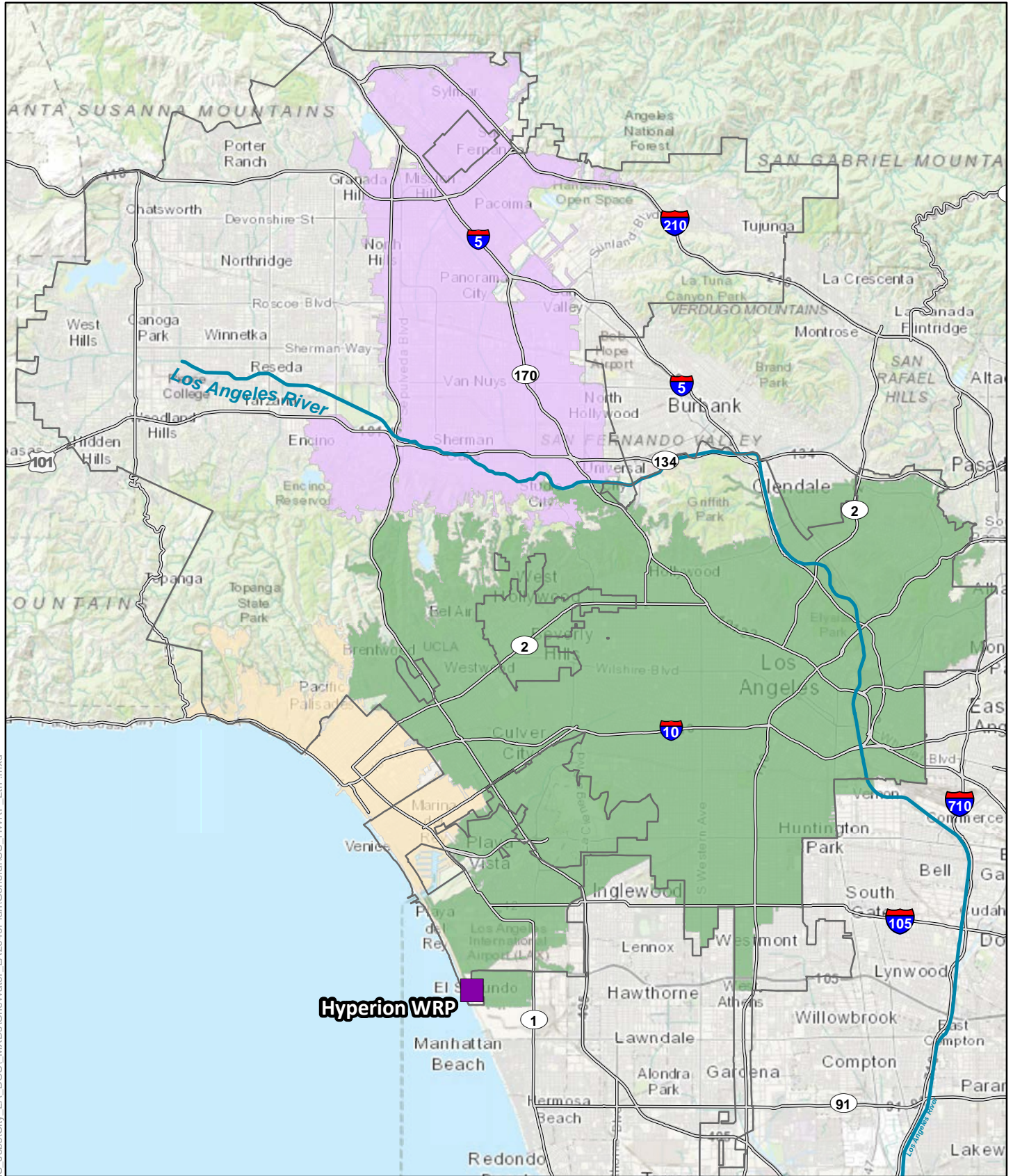

Hyperion WRP

Figure 4.2
HWRP Location and Sewershed
 One Water LA 2040 Plan

- Existing Water Reclamation Plant (WRP)
- CIS Sewershed
- HWRP Metro Sewershed
- Valley Springs Sewershed

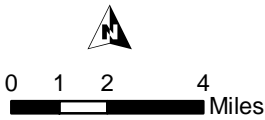

4.1.1 Treatment Process Overview

Currently, HWRP is operated as a full secondary facility utilizing high purity oxygen-activated sludge (HPOAS) process with effluent discharged to Santa Monica Bay through a 5 mile outfall terminating at a depth of 200 feet. The plant has state of the art solids processing units centered on anaerobic digestion and the production of biogas and treated solids for reuse. LASAN has recently begun operations of the new Hyperion Bio-Energy Facility (HBEF) to utilize the HWRP's digester biogas for renewable energy generation.

HWRP is rated and permitted to treat an average flow of 450 mgd, a peak wet weather flow of 850 mgd and a maximum hydraulic capacity of 1,100 mgd. As a result of the success of water conservation, the average flow in 2016 was 250 mgd.

A plant process flow diagram is shown on Figure 4.3. For the liquid treatment processes, HWRP represents a conventional activated sludge plant that uses high purity oxygen.

Processes include:

- Preliminary Treatment
- Primary Clarification
- High Purity Oxygen Activated Sludge
- Secondary Clarification
- Effluent Disposal

Also shown are the sludge management systems including:

- Sludge Thickening
- Anaerobic Digestion
- Dewatering

For individual processes and systems, detailed information is provided in Section 4.1.4 through Section 4.1.14.

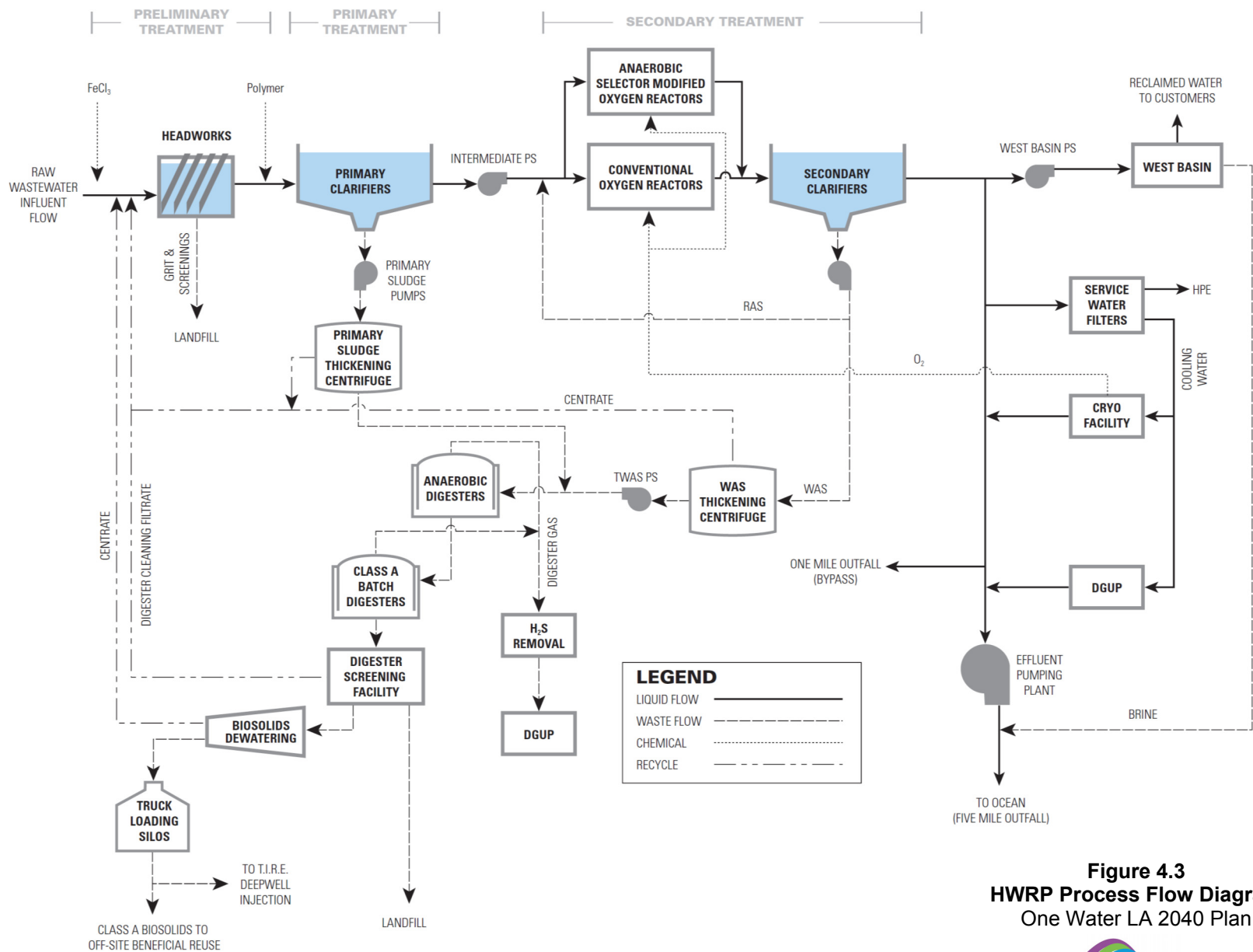

Figure 4.3
HWRP Process Flow Diagram
 One Water LA 2040 Plan



4.1.2 Influent Flows and Characteristics

The influent sewage source into HWRP is currently approximately 90 percent municipal and 10 percent industrial. Design and current values for flow, TSS and BOD are presented in Table 4.1. The average flow is significantly below design value as a result of water conservation, while the TSS and BOD concentrations are higher.

| Table 4.1 HWRP Influent Flows Wastewater Facilities Plan One Water LA 2040 Plan | | |
|-----------------------------------------------------------------------------------------------------------------------------------|---------------------|----------------------------|
| Parameter | Design Value | Value⁽¹⁾ |
| Average Daily Flow | 450 mgd | 263 mgd |
| Peak Daily Flow | - | 478 mgd |
| Average TSS | | |
| Concentration | 302 mg/L | 389 mg/L |
| Mass Loading | 567 tpd | 427 tpd |
| Average BOD | | |
| Concentration | 380 mg/L | 354 mg/L |
| Mass Loading | 713 tpd | 388 tpd |
| <u>Note:</u> (1) Value from July 2014 to June 2015 <u>Abbreviations:</u> mg/L = milligrams per liter; tpd = tons per day | | |

As depicted above, the combination of lower flows and higher constituent concentrations has resulted in mass loadings for TSS and BOD well below plant design values.

4.1.3 Effluent Flows and Characteristics

Following treatment at HWRP, the secondary effluent is discharged to either the ocean or conveyed to the WBMWD ECLWRF for further treatment and water reuse. The HWRP effluent is consistently compliant with the NPDES permit which is summarized in Table 4.2.

| Table 4.2 HWRP NPDES Effluent Limitations Wastewater Facilities Plan One Water LA 2040 Plan | | | | |
|----------------------------------------------------------------------------------------------------------------------------------------------------------------------------------------------------------------------------------------------------------------------------------------------------------------------------------------------------------------------------------------------------------------------------------|----------------|------------------------|-----------------------|------------------------------|
| Constituent | Units | Monthly Average | Weekly Average | Instantaneous Maximum |
| BOD ₅ | mg/L | 30 | 45 | -- |
| | lbs/day | 105,000 | 160,000 | -- |
| TSS | mg/L | 30 | 45 | -- |
| | lbs/day | 105,000 | 160,000 | -- |
| pH | standard units | 6.0 – 9.0 | | |
| Oil and Grease | mg/L | 25 | 40 | 75 |
| | lbs/day | 88,000 | 140,000 | -- |
| Settleable Solids | ml/L | 1.0 | 1.5 | 3.0 |
| Chronic Toxicity | Pass or Fail | -- | -- | -- |
| Ammonia Nitrogen | mg/L | 58 ⁽¹⁾ | -- | 584 |
| | lbs/day | 203,000 | -- | 2.0 x 10 ⁶ |
| Temperature | °F | <100 at all times | | |
| Turbidity | NTU | 75 | 100 | 225 |
| <p><i>Source: NPDES Permit No. CA0109991 Order No. R4-2017-0045</i></p> <p>Note:</p> <p>(1) Values reflect a 6-month median</p> <p>(2) Effluent limitation pertains to Discharge Point 002 (5-mile outfall)</p> <p>Abbreviations:</p> <p>lbs/day = pounds per day; BOD₅ = 5-day biochemical oxygen demand; ml/L = milliliter per liter; NTU = nephelometric turbidity unit; °F = degrees Fahrenheit</p> | | | | |

Treatment of wastewater at HWRP currently meets all NPDES effluent limitations as outlined in Table 4.2.

4.1.4 Process Descriptions

In the sections that follow, HWRP's liquid treatment processes, solids management systems, and ancillary facilities are described, including:

- Component descriptions and design criteria
- Summary of operations
- Current performance metrics

This information provides the foundational basis for the development of future plant improvements.

4.1.5 Preliminary Treatment

The goal of preliminary treatment at HWRP is to protect the plant from materials (such as grit, rags and solids larger than three-quarter-inch) that can clog and damage process equipment, cause excessive wear, or reduce treatment efficiency. Preliminary treatment at the HWRP consists of flow metering, screening, and grit removal. The removed material is safely conveyed to an environmentally sound solid waste disposal facility. Air collection and treatment is provided to reduce odor emissions.

The preliminary treatment process at HWRP was designed to hydraulically handle an influent flow of up to 800-900 mgd, but has historically handled flows up to 1,100 mgd during wet weather events. The various unit components are described below and summarized in Table 4.3.

4.1.5.1 Screening

Screening is the first component of preliminary treatment at HWRP. Screening facilities consist of eight, three-quarter-inch mechanically raked bar screens that remove objects such as rags, paper, plastics, and solid objects to prevent clogging and damage to downstream equipment, piping, and appurtenances. For flexibility in the event of future expansion, two additional bar screens may be installed in two existing channels. In an upcoming capital improvement project, four of the existing screens will be replaced with new three-eighths-inch screens for improved screening effectiveness.

4.1.5.2 Grit Removal

Grit removal is the second component of preliminary treatment at HWRP. Six aerated grit basins remove fine, relatively dense materials, such as sand, that were not removed by the bar screens. Removal of these materials prevents the formation of deposits in plant pipelines and minimizes abrasion in mechanical equipment further downstream in the treatment process.

4.1.5.3 Biotrickling Filter Odor Control System

The odor control system for the Headworks helps to reduce the release of fugitive odors. The odor control system has been upgraded from chemical odor scrubbers to biotrickling filters (BTF). The BTF odor control systems consists of four BTF units, each with three layers of media, eight dual stage adsorber vessels with activated carbon media, six exhaust fans, four mist eliminators and two degreasers.

| Table 4.3 HWRP Preliminary Treatment Facilities Design Criteria ⁽¹⁾ Wastewater Facilities Plan One Water LA 2040 Plan | |
|-------------------------------------------------------------------------------------------------------------------------------------------------|-------------------------------------------------|
| Unit | Value |
| Screens | |
| Type | Mechanically Raked |
| Number | 8 (4 Duty, 4 Standby, 2 slots for future units) |
| Width | 10 ft |
| Capacity, each | 133.3 mgd |
| Model ⁽²⁾ | 3/4 inch, Climber Type |
| Grit Basins | |
| Type | Aerated |
| Number | 6 |
| Volume, each | 22.5 ft x 150 ft x 15 ft deep |
| Sidewater Depth | 15 ft |
| Design Capacity, each | 167 mgd |
| Biotrickling Filters | |
| Design Air Flow | 16,575 cfm |
| Media Type | Matala SFM 365 (Blue) |
| Media Depth | 13.5 (3 layers, 4.5 ft each) |
| Carbon Scrubber Type | Double stage (dual carbon bed) |
| Design Air Flow | 10,000 scfm |
| Bed Type | Coconut Shell Granular Activated Carbon |
| Media Depth, each bed | 3 ft |
| <i>Source: City of Los Angeles Integrated Resource Plan, 2006; Discussions with City staff and Plant personnel.</i> | |
| <u>Notes:</u> | |
| (1) HWRP Headworks was constructed in 1992, Element 106 | |
| (2) Screens are scheduled to be replaced CIP 2409 HWRP Headworks Improvements | |
| <u>Abbreviations:</u> | |
| ft = feet, scfm = standard cubic feet per minute; hp = horsepower | |

4.1.5.4 Operation

Raw wastewater enters HWRP through the NOS, CIS, NCOS, NORS, and the COS. Influent flows are conveyed to the mechanically raked bar screens at HWRP headworks. Ferric chloride is added to plant influent to assist with settling. During regular operation, four of the bar screens operate in duty mode and four of the bar screens are in standby.

Screenings captured by the bar screens are transported by a sluiceway, shredded, and pumped to rotating drum screens for dewatering. Grit collected from the aerated basins is pumped to cyclones and classifiers for washing and dewatering. Following dewatering, screenings and grit are compacted and hauled to a landfill via truck. Flow exiting the grit chambers is directed to the primary clarifiers via a splitter structure located at the south end of the grit basins.

Flow entering HWRP from the CIS has a higher total dissolved solids (TDS) saline content than the other influent sewers as a result of seawater infiltration. In order to achieve the reduced TDS levels for plant effluent sent to the ECLWRF for water reuse, a gate installed between the bar screens and the aerated grit chambers diverts flow from the CIS to Primary Battery A and to Secondary Reactor Module 9. Since the primary source of flow for ECLWRF comes from Secondary Reactor Modules 1 and 2, HWRP is capable of delivering the lowest TDS secondary effluent to ECLWRF under existing process capabilities.

4.1.5.5 Current Performance

Currently at HWRP, 4 out of 8 bar screens (two on the eastside and two on the westside) are in service to handle total plant flow during dry season. Four out of six aerated grit basins are in service to handle total plant flow during dry season. Table 4.4 summarizes the preliminary facilities operational characteristics from July 2014 through June 2015.

| Table 4.4 HWRP Preliminary Characteristics Wastewater Facilities Plan One Water LA 2040 Plan | |
|-------------------------------------------------------------------------------------------------------------|--------------|
| Description | Value |
| Average Preliminary Flow | 263 mgd |
| Grit, Total Solids | 20% |
| Grit, Volatile Solids | 83% |
| <i>Source: Monthly Performance Reports July 2014 to June 2015</i> | |

As Table 4.4 shows, the average grit chamber influent flow is well below the design flow of 800-900 mgd for these facilities. This indicates that besides regular repairs and maintenance, the grit chamber hydraulic capacity will not need to be upgraded to accommodate future flows.

4.1.6 Primary Treatment

After preliminary treatment, the wastewater then flows to the primary clarifiers for primary treatment. Primary treatment at HWRP is the principal means of removing settleable and floatable organic and inorganic materials from flows delivered to the plant. Effluent from the primary treatment process is pumped south of the primaries for secondary treatment. Sludge and scum collected as part of the primary treatment process is pumped north to the anaerobic digesters for stabilization.

The primary treatment facilities at HWRP consist of four batteries of rectangular primary clarifiers (Batteries A, B, C and D). Each of the primary batteries varies in its number of rectangular clarifiers. There are four clarifiers in Battery A, six in Battery B, five in Battery C, and 12 smaller clarifiers (equivalent to four large units) in Battery D. In total, the primary treatment facilities are equivalent to 19 large clarifiers with a total surface area of 327,600 square feet (sq ft). Table 4.5 provides a summary of the primary treatment facility design criteria.

4.1.6.1 Operation

Flow enters each primary tank through influent channel inlet ports. Anionic polymer is injected just downstream of the aerated grit chambers to improve particle settling within the primary clarifiers.

Primary effluent is collected at the opposite end of each battery in a system of steel troughs that convey flow to the primary effluent channels. Primary effluent normally flows to the Intermediate Pump Station (IPS) where it is raised to an elevation to accommodate the hydraulic requirements of the downstream secondary process trains. However, if the IPS is either not functional or flow exceeds the IPS capacity, all or part of the primary effluent can be diverted to Emergency Storage Basins and, if needed, to the Effluent Pumping Plant (EPP) via emergency effluent channels.

Settled sludge is conveyed via a flight and chain loop mechanism to bottom hoppers located at the influent of the sedimentation tanks. The surface loop of the flights convey floatable material to a collection mechanism at the effluent end before the clarified water is conveyed to the secondary process. Sludge and scum collected from all four batteries is pumped to the Primary Sludge Thickening System and eventually digesters via the Primary Sludge Pump Station (PSPS).

| Table 4.5 HWRP Primary Treatment Facilities Design Criteria Wastewater Facilities Plan One Water LA 2040 Plan | |
|------------------------------------------------------------------------------------------------------------------------------|----------------------------------------------------------------------|
| Unit | Value |
| Primary Clarifiers | |
| Treatment type | Gravity settling, enhanced with ferric chloride and polymer addition |
| <i>Primary Battery A</i> | |
| Number (A-1, A-2, A-3, A-4) | 4 |
| Width x Length | 56.5 ft x 300 ft |
| Water Depth | 15.1 ft |
| <i>Primary Battery B</i> | |
| Number (B-1, B-2, B-3, B-4) | 4 |
| Width x Length | 56.5 ft x 300 ft |
| Depth | 15.1 ft |
| Number (B-0, B-5) | 2 |
| Width x Length | 60 ft x 300 ft |
| Depth | 15.1 ft |
| <i>Primary Battery C</i> | |
| Number (C-1, C-2, C-3, C-4) | 4 |
| Width x Length | 56.5 ft x 300 ft |
| Depth | 15.1 ft |
| Number (C-0) | 1 |
| Width x Length | 60 ft x 300 ft |
| Depth | 15.1 ft |
| <i>Primary Battery D</i> | |
| Number (D-1, D-2, D-3, D-4, D-5, D-6, D-7, D-8, D-9, D-10, D-11, D-12) | 12 (Equivalent to 4) |
| Width x Length | 17.5 ft x 300 ft |
| Depth | 15 ft |
| <i>Source: City of Los Angeles Integrated Resource Plan, 2006; Discussions with City staff and Plant personnel.</i> | |

4.1.6.2 Current Performance

While the primary facilities are designed for a surface overflow rate (SOR) of 1,550 to 1,700 gallons per day per square foot (gpd/sq ft) with all primary clarifiers in service, the clarifiers have historically performed at 80 to 85 percent TSS removal rates with an average SOR of 1,400 to 2,000 gpd/sq ft. Table 4.6 summarizes the primary clarifier operational characteristics from July 2014 through June 2015 and shows a drop in removal efficiency.

| Table 4.6 HWRP Primary Clarification Characteristics Wastewater Facilities Plan One Water LA 2040 Plan | |
|-----------------------------------------------------------------------------------------------------------------------|-----------------|
| Description | Value |
| Average Primary Influent Flow ⁽¹⁾ | 318 mgd |
| Average Surface Overflow Rate | 1,405 gpd/sq ft |
| Peak Surface Overflow Rate | 1,699 gpd/sq ft |
| Average BOD Effluent Concentration | 164 mg/L |
| Average TSS Effluent Concentration | 130 mg/L |
| Average BOD Removal Efficiency | 53% |
| Average TSS Removal Efficiency | 66% |
| <i>Source: Monthly Performance Reports July 2014 to June 2015</i> | |
| <u>Note:</u> | |
| (1) This value reflect addition of plant return flows | |

4.1.7 Intermediate Pump Station

The IPS lifts effluent flows with the use of 10 screw pumps from the primaries to a higher elevation that allows for gravity flow via channels to the biological secondary treatment and secondary clarifier processes. An emergency generator is available to power four out of ten pumps in case of a power outage at the IPS.

The IPS screw pumps are designed to lift 125 mgd each for a total capacity of 1,125 mgd with nine pumps in service and one in standby or maintenance. Table 4.7 provides a summary of the IPS design criteria.

| Table 4.7 HWRP Intermediate Pumping Station Facilities Wastewater Facilities Plan One Water LA 2040 Plan | |
|----------------------------------------------------------------------------------------------------------------------------------------------------------------------------------------------------------------|---------------------------------------|
| Unit | Value |
| Type | Screw Pump |
| Model ⁽¹⁾ | Spaans-Babcock Archimedes Screw Pumps |
| Number | 4 duty, 4 standby, 2 maintenance |
| Diameter | 150 inch |
| Capacity, each | 125 mgd/600 hp |
| <i>Sources: Hyperion Full Secondary Design Concept and Implementation Report, DMJM/BV, December 1993; City of Los Angeles Integrated Resource Plan, 2006; Discussions with City staff and Plant personnel.</i> | |
| <u>Note:</u> | |
| (1) Include screw replacements and system upgrades, CIP 2251-2252-2260 Screw Replacement project completed in 2006 | |

4.1.7.1 Operation

Currently, HWRP operates the IPS with 4 screw pumps in service. Any flows in excess of 1,125 mgd bypass the IPS and are delivered to Emergency Storage Basins via an overflow weir and gates in the primary clarifier effluent channels.

4.1.7.2 Current Performance

Table 4.8 provides average flow characteristics for the IPS from July 2014 to June 2015.

| Table 4.8 HWRP IPS Characteristics Wastewater Facilities Plan One Water LA 2040 Plan | |
|-----------------------------------------------------------------------------------------------------|--------------|
| Description | Value |
| Average Primary Effluent Flow | 267 mgd |
| Average Suspended Solids | 134 mg/L |
| Average BOD | 153 mg/L |
| Average Ammonia Nitrogen (NH ₃ -N) | 44 mg/L |
| <i>Source: Monthly Performance Reports July 2014 to June 2015</i> | |

As shown in Table 4.7 and Table 4.8, the four in service pumps yield a total capacity of 500 mgd to handle both average and peak flows. Additional pumping capacity is not needed at this time.

4.1.8 **Secondary Treatment - High Purity Oxygen Generation Facilities**

Pure oxygen is generated on site at the cryogenic air separation facility located east of G Street. The oxygen generated at the cryogenic facility is used to support biological treatment in the secondary reactors. The cryogenic facility consists of five air compressors, two direct contact after coolers, two evaporative cooling towers, eight molecular sieve absorbers, distillation column, three air separation cold boxes, two liquid oxygen (LOX) tanks and pumps, LOX vaporizers, one liquid nitrogen tank, pumps, and cooling water pumps.

The cryogenic facility is located east of the secondary treatment modules and the associated compressor building is located between secondary treatment Modules 7 and 8. The compressor building houses five compressors with an equipment pad for the addition of one compressor in the future. The cryogenic facility is equipped with three distillation columns produce high purity oxygen. Table 4.9 provides a summary of the high purity oxygen facilities design criteria.

| Table 4.9 HWRP High Purity Oxygen Generation Facilities Design Criteria Wastewater Facilities Plan One Water LA 2040 Plan | |
|------------------------------------------------------------------------------------------------------------------------------------------------------------------------------------------------------------------------|------------------------------------------------------------|
| Unit | Value |
| Number of Air Compressors | 5 (3 on-duty, 2 stand-by) |
| Size of Each Compressor | 3,356 kW |
| Direct Contact Aftercooler Size | 10' Diameter by 54' Tall |
| Direct Contact Aftercooler Pump Quantity | 3 (2+1) |
| Direct Contact Aftercooler Pump Capacity | 340 gpm against 60' TDH |
| Evaporative Cooling Tower Size | 10.5' Diameter by 61' Tall |
| Evaporative Cooling Tower Recirculation Pump Quantity | 3 (2+1) |
| Evaporative Cooling Tower Recirculation Pump Size | 125 gpm against 20' total dynamic head (TDH) |
| Mole Sieve Absorbers | 2 banks (1 on-duty, 1 stand-by; each bank has 4 absorbers) |
| Air Separation Cold Box | 3 at 250 tons/day per box |
| Maximum Production Capacity | 770 tons of gaseous oxygen per day |
| Number of LOX Storage Tank | 2 |
| Size of LOX Tanks | 320,000 gallons (1,000 tons) |
| Number of LOX Transfer Pumps | 3 (2+1) |
| LOX Transfer Pumps Size/Capacity | 2 hp (28 gpm against 37 psig head) |
| Number of LOX Vaporizer Pumps | 2 |
| LOX Vaporizer Pump Capacity | 80 gpm against 40 psig head |
| Number of LOX Vaporizer | 2 |
| LOX Vaporizer Capacity | 43,400 lbs/LOX/hr |
| Number of LIN Transfer Pumps | 3 |
| LIN Transfer Pumps Size/Capacity | 3 hp (65 gpm against 110' TDH) |
| Size of LIN Tank | 29,700 gal |
| Product | Gaseous High Purity Oxygen |
| <i>Sources: Hyperion Full Secondary Design Concept and Implementation Report, DMJM/BV, December 1993; Meetings and discussions with City Staff concerning current operation; Hyperion Design Technical Memorandums</i> | |
| Abbreviations: psig = pounds per square inch gauge; lbs/LOX/hr = pounds per liquid oxygen per hour | |

4.1.8.1 Operation

The cryogenic air separation process begins with the compression of filtered atmospheric air through multistage compressors equipped with intermediate (interstage) shell and tube-type cooling system. Residual heat from the final compression stage is removed through the Direct Contact Aftercoolers (DCAC). The DCAC's use treated plant effluent in a closed loop as a cooling medium. Molecular Sieve Absorbers remove any remaining moisture, carbon dioxide, and hydrocarbon compounds. The remaining major components in the air stream are oxygen and nitrogen. The process air continues to the cold boxes, where nitrogen and oxygen will be separated by liquefaction (the process of turning a gas to a liquid) and distillation.

The cold box is a highly insulated, vertical steel structure housing an air separation column and a reboiler-condenser unit. The cold box utilizes counter-current distillation to separate of the process air into almost pure oxygen and nitrogen constituents. Liquid product oxygen (98 percent purity) is piped to the LOX storage tank. LOX is withdrawn from the tank and routed to the main condenser unit for vaporization prior to being piped to HWRP's secondary oxygen reactors. Excess LOX production is transferred to the storage tanks by special cryogenic pumps, thereby ensuring a constant supply of oxygen to the reactors during peak demands. Three pumps recirculate the LOX though the tanks to maintain a constant temperature of the tank inner gas space. In the event of an emergency system shutdown, a second set of the similar pumps are available to pump LOX to the vaporizers to ensure an uninterrupted supply of 98 percent pure oxygen gas to the secondary reactors. The liquid nitrogen (LIN) system does not require the use of pumps to supply the LIN storage tanks, though cryogenic-service pumps are required to provide tank recirculation and to transfer liquid nitrogen back to the cold box.

The secondary treatment process requires a total of approximately 280 tons per day (tpd) of high purity oxygen. Under design year peak daily flow conditions, the cryogenic facility can produce approximately 866 tpd of high purity oxygen to meet the demands of secondary treatment.

4.1.8.2 Current Performance

The high purity oxygen generation equipment is nominally performing as required and assessed by plant staff. However the system has been in operation for over 20 years and is in need of near-term rehabilitation. HWRP staff have been evaluating and assessing individual components of the high-purity oxygen system to identify actions to increase the life and reliability of the equipment.

Following an inspection and an analysis of the existing facilities, the Linde Group produced a series of technical memoranda to recommend a staged process for rehabilitation at the HWRP cryogenic facilities. In the near-term, improvements are essential for addressing corrosion at the cryogenic facilities before problems become critical to operations at HWRP.

Following rehabilitation, Linde's recommendations include upgrades to extend the useful life of the facilities by 15-20 years. This recommended upgrade to the Cryogenic facility should be considered in the context of the timing and compatibility of the entire HPOAS to produce an effluent quality necessary for cost effective water reuse projects.

4.1.9 Secondary Treatment – Reactors, Clarifiers and Pumping

The purpose of secondary treatment is to remove soluble BOD that is not removed by primary treatment and provide further removal of suspended solids. Secondary treatment at HWRP is accomplished using closed reactors with mixers and arranged in nine parallel modules. Each module receives gaseous oxygen to support biological activity for treatment. Three of the modules have been converted to use anaerobic selectors. Each of the nine modules consist of dedicated influent channels, three HPOAS bioreactor trains, and four circular secondary clarifiers.

Design criteria for the secondary reactors and clarifiers is divided by the HPOAS reactors and the secondary clarifiers.

4.1.9.1 High-Purity Oxygen Activated Sludge Reactors (HPOAS)

Each of the nine secondary treatment modules is equipped with three high-purity oxygen reactors for a total of 27 reactors. Per the original design, the reactors in six of the nine modules are divided into five aerobic mixing cells. In the remaining three converted modules, the first cell of the selector reactors is divided into two, thus leaving each reactor with one anoxic cell and four aerobic cells. The anoxic zones were specifically designed to allow for micro-oxygenation to permit controlled growth of filaments needed to augment settling of fines in the clarifiers.

HWRP has space available in the parking lot for another module if another reactor is required. The secondary influent channels and a connection from the IPS are in place to support an additional reactor. Table 4.10 provides a summary of the secondary reactor design criteria. The reactors were designed to receive influent concentrations of BOD and TSS as 290 mg/L and 170 mg/L, respectively. A schematic of the high-purity oxygen reactors is shown on Figure 4.4. Both the original design and converted module design are depicted.

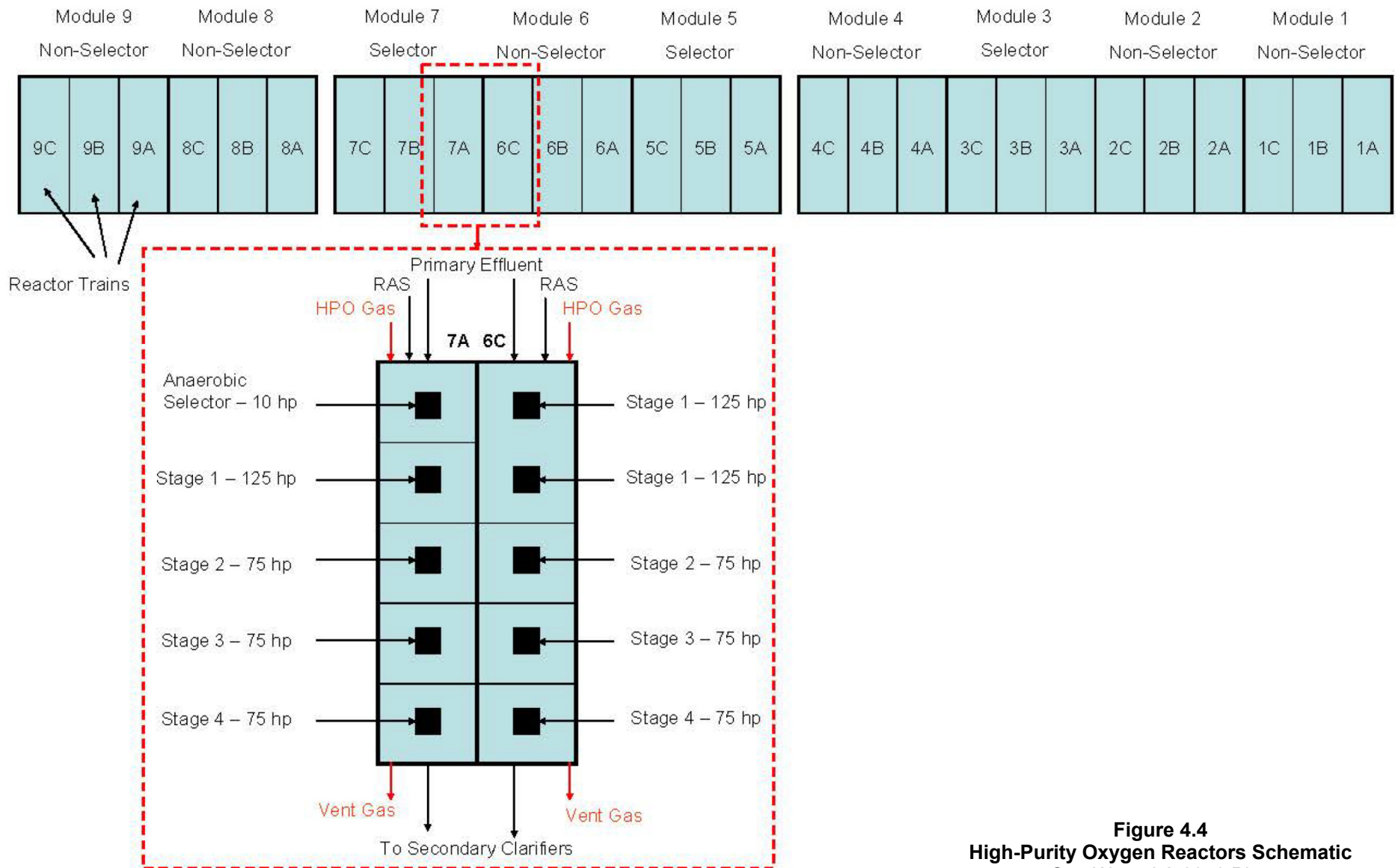

Figure 4.4
High-Purity Oxygen Reactors Schematic
 One Water LA 2040 Plan



| Table 4.10 HWRP Secondary Treatment Design Criteria Wastewater Facilities Plan One Water LA 2040 Plan | |
|---------------------------------------------------------------------------------------------------------------------------------------------------------------------------------|--------------------------------------------------------------------------|
| Unit | Value |
| Secondary Reactors | |
| Type | High-Purity Oxygen |
| Number of Modules | 9 (3 selector, 6 non-selector) |
| Number of Trains per Module | 3 |
| Number of Mixing Cells | Conventional: 1 (108 ft x 54 ft x 25 ft) 3 (54 ft x 54 ft x 25 ft) |
| | Selector: 5 (54 ft x 54 ft x 25 ft) |
| Aerators per Train | 5 for conventional 4 for selector |
| RAS: | |
| % of Influent | 25 - 50 |
| Average, mgd/module | 12 -25 |
| Secondary Clarifiers | |
| Type | Center Inlet, Radial Flow |
| Number | 36 (9 modules, 4 clarifiers per module) |
| Diameter | 150 ft |
| Side Wall Depth | 12 ft |
| Surface Area per Clarifier | 17,670 sq ft |
| Average Design SOR, per clarifier | 649 gpd/sq ft |
| <i>Sources: Hyperion Full Secondary Design Concept and Implementation Report, DMJM/BV, December 1993; Meetings and discussions with City Staff concerning current operation</i> | |

4.1.9.2 Secondary Clarifiers

HWRP has 36 circular secondary clarifiers. There are four secondary clarifiers per module. Mixed liquor from each HPOAS module flows to dedicated mixed liquor splitter boxes. Each mixed liquor splitter box has four downward opening gates for flow splitting between on-line secondary clarifiers. All secondary clarifiers have a 150-foot diameter and a 12-foot sidewater depth. Table 4.10 provides a summary of the secondary clarifier design criteria. Based on the original design criteria, each secondary clarifier is designed for an average SOR of 649 gpd/sq ft.

Mixed liquor enters each secondary clarifier through the center column, passing through ports into a central tub. The mixed liquor exits at the bottom of the tub through a series of specifically designed ports and flow-directing baffles. Collectively, the central tub, discharge ports, and baffles are designed to dissipate the kinetic energy of the incoming mixed liquor

flow. Each clarifier is equipped with a center well that has a diameter of 60 feet delineated by a skirt with a depth of 12 feet (some clarifiers in Module 3 have a slightly modified center well configuration and depth).

Settled sludge is moved along the clarifier bottom towards the center of each clarifier, where the sludge withdrawal hopper is located, using a "window shade" type scraper mechanism. Settled sludge is pumped back to the HPOAS reactors as return activated sludge (RAS). There are six RAS pumps per group of four secondary clarifiers. Each RAS pump has a capacity of 12 mgd. Clarifier effluent flows over v-notch weirs located at the perimeter of each clarifier. A concrete, horizontal "McKinney" baffle protruding from the side wall just below the effluent launders is designed to minimize unwanted end wall effects that can pull solids into the effluent flow streams.

The process capacity of a secondary clarifier is defined by that flow rate beyond which performance, measured in terms of the effluent TSS (ESS) concentration, deteriorates to unacceptable levels. Process capacity is used here to distinguish it from hydraulic capacity. The process intent of secondary clarifiers is to remove settleable solids (i.e., mixed liquor suspended solids [MLSS]) to produce an effluent that meets regulatory requirements.

There are five factors that affect secondary clarifier operations: MLSS concentration, mixed liquor sludge quality characteristics, RAS pump capacity, secondary clarifier surface area, and clarifier hydraulics. Recently, it has been observed that sludge in the secondary clarifiers has poor settleability, caused by filamentous organisms, and poor flocculation, caused by limited oxygen transfer capabilities.

4.1.9.3 Return Activated Sludge and Waste Activated Sludge

Settled sludge collected from the secondary clarifiers is either recycled as RAS and distributed to the head of the secondary reactors or is removed from the system as waste activated sludge (WAS) and delivered to the Waste Activated Sludge Thickening Facility (WASTF).

Each secondary clarifier has an 18-inch magnetic flowmeter, which is inserted inside of a 24-inch sludge hopper suction line. Six RAS pumps are located in the center of each cluster of four clarifiers, with one pump dedicated to each of the four clarifiers and the remaining two RAS pumps on standby. Each group of RAS pumps discharge into two, 30-inch manifolds that combine into a 42-inch RAS discharge pipeline. RAS entering the 42-inch discharge pipelines is then delivered to the head of the secondary reactors and mixed with primary effluent.

Sludge that is not recycled is removed from the system as WAS in order to maintain the desired food-to-microorganism ratio and mean cell residence time in the activated sludge process. Excess activated sludge is removed from the system through a 20-inch diameter pipeline connected to each of the nine, 42-inch discharge pipelines. All WAS lines converge

in a tunnel between the east and west clarifier clusters, and a 12-inch magnetic flowmeter measures WAS flows delivered to the WASTF.

4.1.9.4 Operation

Primary effluent exits the IPS and is delivered to a 600,000 gallon after bay that distributes water through drop boxes to the secondary reactors via nine secondary reactor influent channels.

The reactors were originally designed to operate aerobically with high-purity oxygen introduced to the mixed liquor in the first two cells. Mixing/oxygenation in the first two cells is achieved using 125-hp aerators, and 75-hp aerators provide mixing in the last three cells. To equalize the oxygen-uptake rate, there is no wall separation between the first two cells in each reactor.

To improve settling within the secondary clarifiers, Module 3 and Module 7 have been modified to include anaerobic selector zones. The first two cells of the anaerobic reactors are still mixed; however, a separation wall was constructed between these cells and no high-purity oxygen is conveyed into the first cell. The first cell of the anaerobic reactors is mixed with a 25-hp mixer, the second cell with a 125-hp motor, and the final three cells with a 75-hp aerator. For Module 7, the first cell of the 125-hp mixer was modified to have a variable frequency drive (VFD) driver. Control of filamentous bacteria resulting from the modified anaerobic selector configuration, has improved settling in the secondary clarifiers at HWRP.

Mixed liquor effluent from each oxygen reactor module is delivered to a set of four secondary clarifiers. Settled sludge is removed from the bottom of the secondary clarifiers continuously and a majority of the sludge is returned to the head of the oxygen reactors as RAS. At the head of the secondary influent channels, RAS is mixed with primary effluent at a controlled rate to maintain the population of microorganisms that is optimal for treatment. A smaller portion of the settled sludge is transferred to the solids handling area as WAS.

4.1.9.5 Current Performance

HWRP operations staff report that the combination of low influent BOD concentrations and the addition of ferric chloride and polymer in the primary clarifiers has reduced BOD loading to the secondary treatment process. Additionally, HWRP has improved secondary clarifier performance with the modification of Module 7 to operate with anaerobic selectors.

Operation parameters for the secondary treatment system at HWRP are outlined in Table 4.11.

| Table 4.11 HWRP Secondary Treatment Characteristics Wastewater Facilities Plan One Water LA 2040 Plan | |
|--------------------------------------------------------------------------------------------------------------------------------|------------------------------------------------------------|
| Description | Value |
| Oxygen Reactors Online | 12 trains (distributed through the 9 treatment modules) |
| Mixed Liquor Suspended Solids | 1,986 mg/L |
| Mean Cell Residence Time | 1.6 days |
| Oxygen Use | 251 tons/day |
| Sludge Volume Index | 111.4 mg/L |
| RAS | 87.5 mgd flow at 6,736 mg/L |
| WAS | 5 mgd flow |
| <i>Source: Monthly Performance Reports July 2014 to June 2015. Average from aerobic and anaerobic selector oxygen reactors</i> | |

HWRP currently performs secondary treatment with 12 out of 27 oxygen reactor trains online, indicating that additional capacity is available for higher flows and/or loadings. The HPO system also has available capacity (currently utilizing 251 tpd out of 770 tpd of pure oxygen).

4.1.9.6 Near Term Considerations

The HPOAS has operated successfully for a number of years in reliably meeting all NPDES standards in a cost-effective manner. However, the Cryogenic Oxygen production facilities are in need of rehabilitation. To do so would commit economic resources that could otherwise be used for secondary treatment upgrades necessary for water reuse projects. The HPOAS aeration system cannot be expected to meet nitrogen removal requirements either for water reuse or future potential requirements for ocean discharge. Furthermore, the current clarifiers need improvements and are more than likely not suitable for processing an activated sludge biology optimized for nitrogen removal (nitrification and denitrification). Pilot work is planned at HWRP with the goal of providing site specific data for the most environmentally sound and cost-effective process to prepare for reuse.

4.1.10 Effluent Discharge System

HWRP has the capability to discharge secondary effluent to the ocean through a five-mile outfall in normal conditions and a one-mile outfall in emergency conditions. In the 1950s, a seven-mile outfall for sludge disposal was constructed, but was permanently decommissioned in 1987 and alternative methods of handling digested sludge were employed.

Secondary effluent from HWRP can leave the plant by gravity or is pumped to the five-mile outfall by means of the EPP. A portion of the secondary effluent is delivered to the West Basin Pumping Plant for delivery to the ECLWRF for further satellite treatment through the Hyperion Secondary Effluent Pump Station (HSEPS).

The five-mile outfall is a 12-foot diameter outfall terminating approximately 27,539 feet west-southwest of the HWRP at a depth of approximately 190 feet. The five-mile outfall has two diffuser legs constructed of 102-inch diameter reinforced concrete that tapers to 72 inches in diameter. Each diffuser leg is 4,000 feet in length and has a discharge port every six feet.

The one-mile outfall is a 12-foot diameter reinforced concrete pipeline that terminates in the Santa Monica Bay at a depth of 50 feet. The first 1,550 feet of the one-mile outfall is encased in concrete and the remainder of the pipe is supported on concrete pylons. At the end of the one-mile outfall, water exits through a diffuser that consists of four bulkhead ports and six side ports.

Table 4.12 provides a summary of the Effluent Discharge Facilities design criteria.

| Table 4.12 HWRP Effluent Discharge Facilities Design Criteria Wastewater Facilities Plan One Water LA 2040 Plan | | |
|---------------------------------------------------------------------------------------------------------------------------------------------------------------------------------|--------------------------|-----------------------------------------|
| Description | Five-Mile Outfall | One-Mile Outfall (Emergency) |
| Diameter | 144 inches | 144 inches |
| Material | Precast Concrete | Precast Concrete |
| Length | 27,539 ft | 5,384 ft |
| Discharge Depth (mean sea level) | 190 ft | 50 ft |
| No. of Diffusers Legs | 2 (North and South) | 1 |
| Diffuser Diameter | 102, 72 inches | 144 |
| Length of Diffuser | 4,000 ft/each | 300 ft |
| Diffuser Ports | 83/each | 4-bulkhead ports 6-side ports |
| Port Size | 6.75 to 8.13 inches dia. | 3.25 ft by 1.25 ft (elliptical) |
| <i>Sources: Hyperion Full Secondary Design Concept and Implementation Report, DMJM/BV, December 1993; Meetings and discussions with City Staff concerning current operation</i> | | |

A portion of the secondary effluent is delivered to WBMWD for treatment and water reuse through HSEPS. The HSEPS is located at the southwest corner of the HWRP. Secondary treated effluent is pumped from the HSEPS to ECLWRF via a 60-inch diameter force main.

The HSEPS has a current capacity of 51 mgd. Future planned capacity of the HSEPS is 121 mgd.

The remainder of the flow is either pumped or discharged by gravity through the five mile outfall. The EPP utilizes three duty centrifugal pumps. Operating pressure on the discharge side of the pumps depends on the flow of secondary effluent being pumped, and varies between 18 psi and 33 psi. Table 4.13 provides a summary of the Effluent Pumping Plant design criteria.

| Table 4.13 HWRP Effluent Pump Station Design Criteria Wastewater Facilities Plan One Water LA 2040 Plan | |
|----------------------------------------------------------------------------------------------------------------------------------------------------|----------------------------|
| Unit | Value |
| Type | Variable Speed Centrifugal |
| Number | 5 (3 duty, 2 standby) |
| Power | 2,500 hp |
| Max. Capacity at 64 ft TDH, each | 180 mgd |
| <i>Sources: Hyperion Full Secondary Design Concept and Implementation Report, DMJM/BV, December 1993; Meetings and discussions with City Staff</i> | |

4.1.10.1 Operation

Under routine operations, secondary effluent is pumped by the EPP to HWRP's five-mile outfall and discharged to the ocean. Under emergency circumstances such as extremely high flows, power failures, storm conditions, or testing of emergency bypass gates, HWRP discharges disinfected secondary effluent via the one-mile outfall. HWRP has projected that with a 4.2 feet mean sea level (MSL) and an EPP wet well level of 27 feet, the EPP has a pumping capacity of 720 mgd with four pumps in operation and one in standby. The maximum discharge capacity utilizing both outfalls is 1,447 mgd. Table 4.14 summarizes the capacities of the one-mile and five-mile outfalls. The EPP was recently upgraded and outfitted with new controls.

| Table 4.14 HWRP Ocean Outfall Capacities (mgd) Wastewater Facilities Plan One Water LA 2040 Plan | | | |
|--------------------------------------------------------------------------------------------------------------------------------------------------------------------------------------------------------------------------------------------------------------|----------------------------------------|---------------------------------------|-----------------------|
| Flow Condition⁽¹⁾ | Five-Mile Outfall⁽²⁾ | One-Mile Outfall⁽³⁾ | Total Capacity |
| Gravity Only | 350 | 727 | 1,077 |
| 4 Pumps + One-Mile Gravity | 720 | 727 | 1,447 |
| Notes: | | | |
| (1) The gravity capacity is determined at 4.2 feet mean-sea-level (MSL) tide provided the diffuser ports are cleaned properly. A friction factor $n = 0.015$ is used for both outfalls. | | | |
| (2) An 18-inch brine line from the reverse osmosis process at the West Basin Water Reclamation Plant discharges into the HWRP five-mile outfall. The ultimate flow from this line is 3.5 mgd and is considered insignificant to the capacity of the outfall. | | | |
| (3) NPDES permit states that the one-mile outfall is only to be used for emergency discharge or planned maintenance on five-mile outfall. | | | |

4.1.10.2 Current Performance

As shown in Table 4.15, the effluent discharging from the five-mile outfall is well below the monthly discharge limitations of 30 mg/L for both suspended solids and BOD.

| Table 4.15 HWRP Effluent Discharge Characteristics Wastewater Facilities Plan One Water LA 2040 Plan | |
|---------------------------------------------------------------------------------------------------------------------|--------------|
| Description | Value |
| Average Suspended Solids | 20 mg/L |
| Average BOD | 18 mg/L |
| Average BOD Removal Efficiency | 88% |
| Average TSS Removal Efficiency | 84% |
| <i>Source: Monthly Performance Reports July 2014 to June 2015</i> | |

Since average discharge concentrations of both TSS and BOD are below the discharge limitations, HWRP will be able to continue its current level of treatment without major changes to operation in the short term. However, future changes to discharge regulations, opportunities for increased water reuse or advances in treatment may lead to additional upgrades at the plant.

4.1.11 Solids Processing

HWRP is responsible for processing solids generated in the Hyperion Service Area and associated with bypass flows from DCTWRP, LAGWRP, BWRP, and LAZTF. The primary sources of solids at HWRP are primary sludge removed in the primary clarifiers and WAS generated from the secondary activated sludge process. The WAS is thickened and mixed with thickened primary sludge and then processed through thermophilic anaerobic

digestion. The digested sludge is then dewatered using centrifuges prior to land application. The centrate is returned to the plant influent. A discussion of the strategy for biosolids management at HWRP is summarized in Chapter 9 "Biosolids Management".

Additionally, HWRP collects solids generated during screening and grit removal and disposes them at an offsite landfill.

4.1.11.1 Grit and Screenings Dewatering Facilities

To facilitate transport and disposal, screenings captured by bar screens at the headworks of HWRP are collected and dewatered prior to delivery to an offsite landfill. Grit collected at the headworks is pumped from the grit basin hoppers to dewatering equipment. Flat belt conveyors carry grit from the dewatering units to bins that are loaded into trucks and hauled to a landfill. Rags that are removed at the headworks are handled separately from other solids and are disposed in a landfill.

4.1.11.2 Primary Sludge Thickening Facility

The goal of sludge thickening is to reduce the volume of raw sludge and thereby more efficiently use downstream processes, in particular the anaerobic digesters. Sludge and scum collected from primary batteries is pumped to the Primary Sludge Thickening Facility. The Primary Sludge Thickening System consists of 5 feed pumps (2 duty and 3 standby), 3 centrifuges, and 3 thickened primary sludge pumps (1 duty and 2 standby). Design criteria is summarized in Table 4.16.

| Table 4.16 HWRP Primary Sludge Thickening Facilities Design Criteria Wastewater Facilities Plan One Water LA 2040 Plan | |
|---------------------------------------------------------------------------------------------------------------------------------------|----------------------------------|
| Description | Value |
| Type | Westphalia Centrifuge |
| Number | 1 duty, 1 standby, 1 maintenance |
| Capacity, each | 1,500 gpm |
| Feed Rate | 500 to 1,200 gpm |
| Power, each | 500 hp |
| Chemical Conditioning | Cationic Polymer |
| <i>Sources: Meetings and discussions with City Staff concerning current operation</i> | |

4.1.11.3 Waste Activated Sludge Thickening

The goal of sludge thickening is to reduce the volume of raw sludge and thereby more efficiently use downstream processes, in particular the anaerobic digesters. WAS removed from the secondary clarifiers is thickened using high-speed, solid-bowl centrifuges at the Waste Activated Sludge Thickening Facilities (WASTF). The WASTF consists of 12 centrifuges and there are provisions to add 12 additional units. Table 4.17 provides a summary of the WASTF design criteria.

| Table 4.17 HWRP Waste Activated Sludge Thickening Facility Design Criteria Wastewater Facilities Plan One Water LA 2040 Plan | |
|---------------------------------------------------------------------------------------------------------------------------------------------------------------------------------|----------------------------------|
| Description | Value |
| Type | Centrifuge |
| Number | 8 duty, 3 standby, 1 maintenance |
| Capacity, each | 2,500 lbs/hr |
| Feed Rate | 300 to 1,000 gpm |
| Power, each | 300 hp |
| Chemical Conditioning | Cationic Polymer |
| Storage tank Capacity | 40,000 gal |
| Sources: <i>Hyperion Full Secondary Design Concept and Implementation Report, DMJM/BV, December 1993; Meetings and discussions with City Staff concerning current operation</i> | |
| Abbreviation: lbs/hr = pounds per hour | |

4.1.11.4 Anaerobic Digestion

The anaerobic digesters reduce the mass of sludge, stabilize the organic material present, enhance dewaterability, and produce a usable fuel (digester gas). HWRP anaerobic digestion facilities operate as a two-stage system. Stage 1 consists of 16 modified egg-shaped anaerobic digesters operated on a continuous flow basis. Stage 2 consists of four batch flow modified egg-shaped digesters. The digesters are fed primary and secondary sludge on a continuous basis for stabilization and solids reduction. The product of the first stage units is fed into the second-stage digestion process operated in a fill-hold-draw batch sequence to provide Class A biosolids. The product of the batch is fed to the dewatering system.

Table 4.18 provides a summary of the Anaerobic Digestion Facilities design criteria.

| Table 4.18 HWRP Anaerobic Digestion Facilities Design Criteria Wastewater Facilities Plan One Water LA 2040 Plan | |
|---------------------------------------------------------------------------------------------------------------------------------------------------------------------------------|-----------------------------------------------------------------------------------------------------------------------------------|
| Unit | Value |
| Battery D1, D2, and E | |
| Type | Modified Egg-Shaped, Pump Recirculation System First Stage Internal Draft-Tube Mixing Second Stage Externally Pumped Mixing |
| Number of Digesters | 20 (16 First Stage Digesters 4 Second Stage Digesters) |
| Configuration | 3 Batteries with 6 Digesters each + 2 |
| Operating Status | Continuous/Batch Thermophilic Digestion First Stage Continuous Second Stage Batch Mode |
| Continuous Feed Mode Digesters | 16 |
| Batch Mode Digesters | 4 |
| Diameter at Belt | 85 ft |
| Center Depth | 110 ft |
| Volume, each | 2.5 MG |
| Gas Production | 7,100,000 ft ³ /day |
| <i>Sources: Hyperion Full Secondary Design Concept and Implementation Report, DMJM/BV, December 1993; Meetings and discussions with City Staff concerning current operation</i> | |

4.1.11.5 Sludge Dewatering

Dewatering substantially reduces the volume of sludge and converts it to a truckable and spreadable product to facilitate its ultimate disposal/reuse. Digested sludge is sent to the HWRP sludge dewatering facilities, which includes the:

- Digested sludge screening facility
- Sludge dewatering centrifuge facility
- Dewatered (biosolids) cake storage
- Truck loading facility

The digested sludge screening facility provides pretreatment of sludge using 2-stage metal-mesh static screens configured in four trains to remove excess fibrous material, hair, and grit from the sludge. The screenings are belt pressed for additional water removal and transported to storage hoppers via shaftless screw conveyors. The grit pad is used as a drying area for the screenings to achieve the required solids content prior to being taken to

the landfills. Sawdust is added to increase the solids content of the grit while an odor neutralizing spray system reduces the potential for foul odors.

The screened sludge is pumped to the centrifuge facility for dewatering. The dewatering centrifuge facility consists of six solid-bowl high speed centrifuges and six dedicated wetcake pumps. The truck loading facility has eight storage and loading silos within four loading bays and four truck scales. Table 4.19 provides a summary of the Digested Sludge Processing Facility design criteria.

| Table 4.19 HWRP Digested Sludge Processing Facilities Design Criteria Wastewater Facilities Plan One Water LA 2040 Plan | |
|---------------------------------------------------------------------------------------------------------------------------------------------------------------------------------|---------------------------------------------|
| Unit | Value |
| Screening | |
| Type | Metal-mesh 2-stage Static Hydrosieve Screen |
| Width of Openings | 0.06 inch top, 0.04 inch bottom |
| Number of Trains | 4 |
| Number of Screens per Train | 4 |
| Width of Screens | 6 ft |
| Dewatering | |
| Dewatering Interim Centrifuge Expansion (DICE) II | |
| Current Number | 6 |
| Type | Centrifuge (Alfa Laval G3) |
| Number | 3 duty, 2 standby, 1 maintenance |
| Future Number | 2 |
| Capacity | 1000 gpm |
| Feed Rate | 500-800 gpm |
| Power | 250 hp |
| Truck Loading Facility | |
| Type | Coated Metal Silos with bottom feeders |
| Number of Truck Bays | 4 |
| Number of Silos | 8 |
| Capacity, each | 100 tons |
| <i>Sources: Hyperion Full Secondary Design Concept and Implementation Report, DMJM/BV, December 1993; Meetings and discussions with City Staff concerning current operation</i> | |

4.1.11.6 Operation

Sludge and scum collected during primary treatment are pumped to a primary sludge pump station that convey the sludge to primary sludge thickening centrifuges prior to the anaerobic digesters. Piping provisions are set up to bypass the primary sludge to thickening centrifuges and pump directly to the digesters if operational scenarios require.

WAS is delivered to the WASTF from the secondary clarifiers by variable speed pumps that are controlled by system pressure. This allows for a constant flow, determined by the desired sludge-wasting rate, to be delivered to each centrifuge. A polymer system assists in achieving thickening goals. WAS is thickened approximately 7.0 percent solids concentration (average from July 2014 to June 2015). The thickened sludge from the centrifuges is discharged by gravity to a wet well and pumped to the anaerobic digesters.

Thermophilic operation provides approximately 55 to 60 percent destruction of the volatile solids contained in the sludge. Heat added to the digesters by direct injection of steam together with internal mixing provides the optimum temperature range to accomplish pathogen reduction and methane gas production. The two-stage process results in a Class A product.

Screened digested sludge is pumped to the solid-bowl-scroll centrifuges. With the addition of cationic polymer, digested sludge is dewatered to a concentration of about 27 to 30 percent solids and delivered to the storage silos. Centrate from this process is sent back to the head of the plant.

Dewatered biosolids are removed from the storage silos, loaded onto trucks, then hauled offsite for beneficial reuse through land application. Biogas generated from anaerobic digestion is exported to the HBEF which will provide HWRP with complete power reliability within its operational control.

4.1.11.7 Current Performance

Through discussions with HWRP staff, the solids processing facilities are operating as expected.

4.1.12 Digester Gas Handling and Power Generation Facilities

Digester gas provides a usable fuel source for power production. Digester gas facilities consist of:

- Intermediate pressure compressors
- Digester-gas LoCat desulfurization scrubbers
- Emergency digester gas flares
- HBEF

The digesters at the HWRP produce an average of 4,000 standard cubic feet per minute (scfm) of digester gas. Following compression to increase its pressure and facilitate conveyance digester gas is initially processed at the plant's LoCat desulfurization facility for removal of hydrogen sulfide. Digester gas is then conveyed to the HBEF where further treatment takes place for removal of moisture and siloxane that can damage equipment downstream. Digester gas is then compressed to approximately 395 psig (pounds per square inch) and if needed supplemented with natural gas. The mixture of these gases enters the combustion turbine generators (CTG) to power the turbines and produce electrical power. The Heat Recovery Steam Generators (HRSGs) then take the exhaust gas from the CTGs to produce high pressure steam (350 psig) to drive the steam turbine generators (STG) and produce additional electrical power. In addition, the STG produces the required low pressure steam (90 psig) to the plant's digesters. As a result, HWRP is an energy self-sufficient facility, not needing to purchase electric power or steam. Table 4.20 provides a summary of the HBEF and equipment design criteria.

| Table 4.20 HWRP HBEF Design Criteria Wastewater Facilities Plan One Water LA 2040 Plan | |
|---------------------------------------------------------------------------------------------------------------------------------------------|---------------------------------------------------------------------------------------------------------------------------------------------------------------------------------------------------------------|
| Unit | Value |
| Each of two CTGs/HRSGs | 11.35 MW |
| One Condensing-Extraction STG | 7.8 MW |
| One Backpressure STG | 1.0 MW |
| Fuel Gas Compression and Supply System | Two siloxane removal vessels (one operating at a time) First stage compressor and cleaning systems: 6,000 scfm Swing compressor: 9,870 scfm Second stage compressor: 8,160 scfm Thermal Oxidizers |
| Selective Catalytic Reduction (SCR) | 25 ppmvd NO _x using 19% aqueous ammonia |
| Ammonia tank (19% aqueous) | 10,000 gallons |
| Two Transformers | 55 MVA |
| One Emergency Diesel Engine Generator | 750 kW firing ULSFO |
| Oil/Water Separator | 2,500 gpm |
| ULSFO Storage Tank | 1,000 gallons aboveground |
| <i>Sources: Final Environmental Impact Report for Hyperion Treatment Plant Digester Gas Utilization Project: Power and Steam Generation</i> | |
| <u>Abbreviation:</u> | |
| MVA = mega volt ampere; MW = megawatt; ULSFO = ultra-low sulfur fuel oil | |

4.1.12.1 Operation

Gas from the anaerobic digesters is treated to remove impurities (sulfur, moisture and siloxane), compressed and mixed (as needed) with natural gas to moderate fluctuations in digester gas productions to provide a dependable blended mixture of digester gas and natural gas to the two Solar Mars 100-1600 CTGs. The CTGs are utilized for the combined cycle cogeneration and can run on just digester gas or the combined digester gas and natural gas to generate electricity. Each CTG is provided with one HRSG which uses the hot exhaust gas from the CTGs to generate superheated steam. The steam is sent to the STGs for electricity production. Exhaust steam from the last stage of STGs is directed to the condenser which uses secondary effluent water to cool the steam. The condensed steam is then pumped to the boiler feedwater pump for the HRSG.

The SCR system uses a 19 percent aqueous ammonia solution as an air pollution control device to reduce the concentration of NO_x at the post-combustion outlet of the HRSG. Black start diesel generators are installed on site to provide power to start the CTGs in the case of a power failure at the facility and on the grid. The generator can provide power for the auxiliary equipment and one CTG. Another diesel generator is available to power the cooling water backup system in the event of an interruption in utility power.

A more detailed schematic of the HBEF operations is shown on Figure 4.5.

4.1.12.2 Current Performance

The HBEF was recently constructed and is in startup. Therefore, limited performance data is available at this time.

4.1.13 Ancillary Facilities

HWRP has a number of ancillary facilities to support daily operations at the plant. These facilities include the Service Water Facility, the Industrial Water System, Odor Control Facilities and the distributed control system.

The descriptions of ancillary facilities at HWRP are included in the following sections.

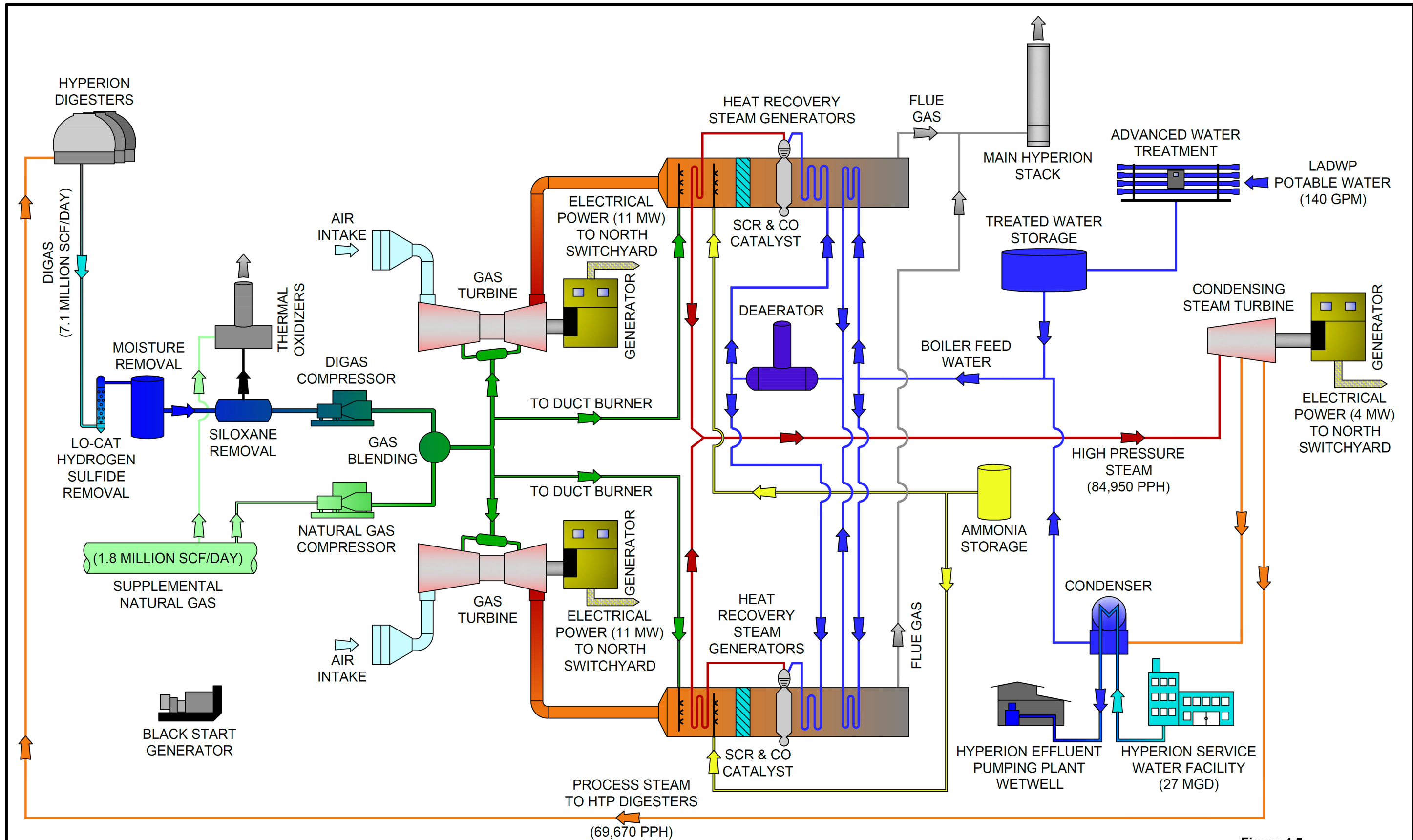

Figure 4.5
HBEF Schematic
 One Water LA 2040 Plan



-This Page Left Blank Intentionally-

4.1.13.1 Service Water Facility

The Service Water Facilities at HWRP function to produce water for in-plant uses. Table 4.21 summarizes Service Water Facility components and design criteria.

| Table 4.21 HWRP Service Water Facility Design Criteria Wastewater Facilities Plan One Water LA 2040 Plan | |
|---------------------------------------------------------------------------------------------------------------------------------------------------------------------------------|-------------------------------------------------------------------------------|
| Unit | Value |
| Number of Low-Lift Vertical Propeller Pumps | 7 (rated at 2.6 mgd each) |
| Number of Disc Filters | 12 (6 north side @ 4 mgd capacity each & 6 south side at 6 mgd capacity each) |
| Number of HPE Pumps | 5 (rated at 5 mgd each) |
| Number of Cooling Water Pumps | 8 (3 rated at 7.2 mgd, 5 rated at 14.4 mgd) |
| Number of Pressure Filter Influent Pumps | 3 (rated at 5.18 mgd) |
| Average Cooling Water Consumption | 5 mgd |
| Average HPE Consumption | 6 mgd |
| Number of Chlorine Contact Basins | 2 below grade of concrete |
| Future Cooling Water Consumption (Cryo+HBEF) | 30 mgd |
| Capacity of HPE Storage Basin | 250,000 gallons |
| <i>Sources: Hyperion Full Secondary Design Concept and Implementation Report, DMJM/BV, December 1993; Meetings and discussions with City Staff concerning current operation</i> | |
| <u>Abbreviation:</u> HPE = high pressure effluent | |

Cooling water produced by HWRP Service Water Facilities consists of HWRP effluent that has passed through drum screens. High Pressure Effluent (HPE) is HWRP effluent that has passed through drum screens, pressure filters, and has been disinfected with sodium hypochlorite (NaOCl).

4.1.13.2 Odor Control Facilities

Foul air from the following processes is vented to and treated by the HWRP Odor Control Facilities:

- Influent Sewers
- Headwork's Facility
- Primary Sedimentation Tanks
- HPOAS Reactors

- Digester Gas Desulfurization Facility Oxidizer Tanks
- Digester Screening Facility
- Biosolids Storage Facility
- Biosolids Truck Loading Facility
- Intermediate Pumping Station

The Odor Control Facilities contain 44 packed tower scrubbers utilizing sodium hypochlorite (NaOCl) and 21 activated carbon towers utilizing virgin activated carbon. The facilities also contain an odor neutralizing system at the Grit Pad.

4.1.13.3 Los Angeles Wastewater Integrated Network System (LAWINS)

In 2011, Honeywell International Incorporated was awarded a 15-year contract to completely overhaul the technology controlling the City's wastewater treatment system. The Distributed Control System (DCS) technology will allow the City to link its four main treatment plants with geographically dispersed pumping stations to give operators the ability to effectively and efficiently control and monitor the entire system, more than 500 square miles of the City's service area, from a central location. Updates include documenting wire terminations, designing and replacing control systems hardware, field cabinetry, development of software, design of control strategies and programming control codes and graphic control screens, design and installation of fiber optic backbone, and process data integration to LASAN business network. The migration of the existing control system to Honeywell DCS is expected to be completed in 2016-2017.

4.1.14 Recent and Ongoing Plant Upgrades

A variety of projects for each of the processes at HWRP have been planned or are currently underway to increase the plant's overall reliability and efficiency. The following projects in Table 4.22 replaced, rehabilitated or upgraded process components at the plant, and were in construction by March 2017. Planned projects that begin construction after March 2017 are summarized in Section 4.5 and listed in Appendix H. Planned completion dates are shown in parenthesis at the end of the description. Projects that have been completed are noted as such.

| Table 4.22 HWRP Recent and Ongoing Plant Upgrades Wastewater Facilities Plan One Water LA 2040 Plan | | | |
|--------------------------------------------------------------------------------------------------------------------|------------------|--------------------------------------------------------|--------------------------------------------------------------------------------------------------------------------------------------------------------------------------------------------------------------------------------------------------------------------------------------------------------------------------------------------------------------------------------------------------------------------------------------------------------------------------------------------------------------------------------------------|
| Process | Project # | Project Title | Description |
| Preliminary | 2239 | Screenings Handling Improvements | This project has improved the existing screenings handling system at the Headworks Facility with the supply and installation of new grinders, screenings compactors and screenings loading equipment which was all integrated with HWRP's Distributed Control System (DCS). The project also demolished existing grit dewatering equipment on the third floor of the Headworks Materials Handling Building as well as twelve (12) existing sluice gates on the aerated grit basins and replaced them with twelve bulkhead slots. (12/2017) |
| Preliminary | 2407 | Grit Handling Improvements | This project is replacing the existing grit handling systems. It is covering all aspects of the current system including grit withdrawal, grit pumping and grit dewatering. It is also upgrading the auxiliary systems, and upgrading the solids collections and handling system to accommodate the increased volume of captured solids. (12/2017) |
| Preliminary | 2409 | Headworks Improvements | This project is replacing eight (8) existing 3/4-inch bar screens with four (4) 3/8-inch bar screens and four (4) 3/4-inch bar screens. (6/2019) |
| Preliminary | 2344 | Headworks Odor Control Upgrade | This project is replacing various components of the Headworks Odor Control System, such as the chemical addition system, metering pumps, piping and various other elements. (7/2019) |
| Primary | 2431 | Primary Influent Gates Replacement | This project replaced the existing four primary influent sluice gates with new 316 stainless steel gates, frames (including shell), rails, and hydraulic rams. Electrical conduits and sensors have been replaced and concrete has been rehabilitated and equipped with T-lock protective lining. (Complete) |
| IPS | 2442 2249 | IPS Screw Pumps Procurement, Installation, and Upgrade | This project removed and recycled 6 stainless steel screw pump barrels, including upper and lower bearings and shafts. 6 new carbon steel coated screw pumps with conical upper ends, upper and lower bearings, and shafts were installed. Run-time recording devices were installed and connected to the Distributed Control System. The Distributed Control System was programmed to receive new signals from the Pump Protection System. (Complete) |
| Cryogenic Facilities | 8123 | Cryo System Modifications | This project included oxygen piping repairs and replacement of FLEXITRAYS and structured packing at the Direct Contact After Cooler and the Evaporative Cooling Tower, respectively. In addition, this project |

| Table 4.22 HWRP Recent and Ongoing Plant Upgrades Wastewater Facilities Plan One Water LA 2040 Plan | | | |
|--------------------------------------------------------------------------------------------------------------------|------------------|----------------------------------------------------|--------------------------------------------------------------------------------------------------------------------------------------------------------------------------------------------------------------------------------------------------------------------------------------------------------------------------------------------------------------------------------------------------------------------------------------------------------------------------------------------------------------------------------------------------------------------------------------------------------------------------------------------------------------------------------------------------------------------------------------------------------------------------------------|
| Process | Project # | Project Title | Description |
| | | | removed and replaced a 20' section of the 24-inch Gas Oxygen (GOX) header. (Complete) |
| Secondary | 2438 | Secondary Clarifier Modules 1-5 Upgrade | This project will rehabilitate the structural components of 20 of the 36 Secondary Clarifiers in Modules 1-5. (12/2019) |
| Secondary | 2422 | Secondary Upgrade Phase 1 | This project rehabilitated the structural components that are experiencing severe corrosion at 16 of the 36 Secondary Clarifiers at the Plant. (Complete) |
| Effluent Discharge | 2390 | Effluent Pumping Plant Header Replacement | This project replaced all the Effluent Pumping Plant header system components by patch welding and carbon fiber lining of portions of the deteriorated steel. (Complete) |
| Effluent Discharge | 2437 | 1-Mile Outfall Structural Rehabilitation | This project will rehabilitate and re-ballast the HWRP 1-mile Outfall. These type of repairs are part of regular maintenance during the course of the outfall's useful life. (9/2018) |
| Solids Handling | 2376 | Dilute Polymer Pump Improvement | This project evaluated the polymer system at the C-7 building and developed alternatives to meet future demands. (Complete) |
| Digester Gas Handling | 1027 | Digester Gas Desulfurization Facility Improvements | The existing desulfurization plant has not been upgraded/modified since a major process change in 1994. This project performed evaluation of the facility and modifications. Some of the identified area of concerns are: (1) H ₂ S removal capacity. The inlet H ₂ S concentration may increase when the digestion process is changed from mesophilic to thermophilic digestion. (2) Redundancy to the system. It was recommended that some minimum redundancy for the existing rotating equipment and coalescing filters (these are prone to plugging) be provided. (3) Upgrade the instrumentation and control system to the level required for compatibility with the overall Plant control philosophy. And (4) Lead Abatement at the facility. (Complete) |
| Digester Gas Handling | 8146 | Digester Gas Piping System Controls | Project provides for procurement and installation: Six 3-inch High Pressure (HP) Flow Control Valves w/ Actuators Six Low Pressure (LP) Flow Control Valve Actuators (18-inch) and appurtenances (positioner, electro-pneumatic converter. (12/2018) |

| Table 4.22 HWRP Recent and Ongoing Plant Upgrades Wastewater Facilities Plan One Water LA 2040 Plan | | | |
|--------------------------------------------------------------------------------------------------------------------------------------------------------------------------------------------------------------------------------|------------------|--------------------------------------------|-------------------------------------------------------------------------------------------------------------------------------------------------------------------------------------------------------------------------------------------------------------------------------------------------------------------------------------------------------------------------------------------------------------------------------------------------------------------------------------------------------------------------------------------------------------------------------------------------------------------------------------------------------------------------------------------------------------------------------------------------------------------|
| Process | Project # | Project Title | Description |
| Digester Gas Handling | 8138 | Compressor Facility Enhancement | The scope of this project is to provide enhancements to the Digester Gas Compressor Facility. The enhancements will consist of new pressure gauges, level sensors, thermostatic valves and other instruments. In addition, instruments will be relocated to locations that are assessable. (3/2018) |
| Digester Gas Handling | 1069 | Flares System Upgrade | The HWRP Flares Systems Upgrade project provided for replacement of the gas burners in three of the six existing flares, modification of the pilot gas supply systems for 5 of the six flares, replacement of the six existing Local Control Panels (LCP) associated with the individual flares with PLC-based units incorporating a local temperature controller for each of the flares (including modification of the temperature control logic for optimized control of the air dampers), replacement of the existing pneumatic-based Central Flare System Controller (CFSC) with a new PLC-based system (including a LP Gasholder Level Controller, an HP Gas Pressure Controller and a balance of work required for safe and reliable operations. (Complete) |
| Digester Gas Handling | 8128 | Main Switchyard – DGUP Autosynchronization | This project provided automatic synchronization with the LADWP grid at the HWRP Main Switchyard. It also upgraded the relay system. (Complete) |
| <i>Sources: Wastewater Treatment Plants Master Schedule, City of Los Angeles Bureau of Engineering; Wastewater Capital Improvement Program, Clean Water Program, City of Los Angeles Hyperion Design Technical Memorandums</i> | | | |

In addition to the projects listed in Table 4.22, the LASAN fosters a vision to fully utilize effluent for water reuse, including potable reuse and industrial uses. Currently, LASAN is investigating options for on-site advanced water treatment, which could affect the design and operation of secondary treatment at HWRP.

LASAN has reviewed the following secondary process alternatives to achieve the higher levels of nitrogen removal required to reuse HWRP effluent: Air Activated Sludge in a Modified Ludzack-Ettinger configuration, MBR (both Air and Pure Oxygen), and Granular Activated Sludge. As LASAN compares these alternatives, the following goals are taken into consideration:

- Maximize both use of the existing site and facilities
- Use technology proven at the scale of HWRP
- Maximize the underlying capacity of HWRP
- Minimize the impact on ongoing operations during transition periods

- Ensure compatibility with downstream membrane treatment systems
- Maintain consistency with long-term plans for aeration systems
- Comply with existing hydraulic constraints

4.2 IN-PROGRESS PROJECTS

In-Progress projects are planned supply projects for groundwater, recycled water, and stormwater that are expected to be implemented outside and independent of the One Water LA 2040 Plan. For HWRP, two In-Progress Project have been identified. These are

- Advanced Treated Recycled Water Delivery to LAX and Scattergood Generating Station
- HWRP Delivery Expansion to 70 mgd for WBMWD and LA Harbor Area

Information is provided for each including:

- Project description
- System requirements
- Requirements for system upgrades
- Design criteria

These projects represent near term improvements to increase water reuse of HWRP effluent. Information on estimated yield and cost are provided in Table 4.23.

| Table 4.23 HWRP In-Progress Projects Wastewater Facilities Plan One Water LA 2040 Plan | | | |
|------------------------------------------------------------------------------------------------------------------------------------------------------------------------------------------------------------------------------------------------------------------------------|-------------------|--------------------------------------|---------------------------|
| Title | Type | Estimated Yield (Normal Year) | Capital Cost (\$M) |
| Advanced Treated Recycled Water Delivery to LAX and Scattergood Generating Station | Non-Potable Reuse | Up to 5,600 AFY (5 mgd) | \$38 ⁽¹⁾ |
| HWRP Delivery Expansion to 70 mgd for WBMWD and LA Harbor Area | Non-Potable Reuse | 39,200 AFY (35 mgd) | \$16 ⁽²⁾ |
| Notes: | | | |
| (1) Cost of phase 1 of this project is estimated at \$38 million, scheduled to occur in the near-term. Expansion of additional 3.5 mgd (product water) could occur in the mid-term, for an estimated capital cost of \$92 million for a total capital cost of \$130 million. | | | |
| (2) The estimated capital cost is for the expansion of the pump station and does not include WBMWD's costs. An additional cost of \$400 million could be incurred in the future should 70 mgd of MBR treatment be installed at HWRP. | | | |

4.2.1 Advanced Treated Recycled Water Delivery to LAX and Scattergood Generating Station

Proposed facilities include the HAWPF. The first phase of the HAWPF will be a 1.5 mgd (expandable up to 5 mgd as additional users are identified) advanced water treatment facility serving LAWA, HWRP internal users, and other potential users within the immediate vicinity. The facility will be built in two phases, 1.5 mgd and an additional 3.5 mgd to accommodate increasing demands, if they occur. Potable water will be provided as makeup water in the event that the demand exceeds the capacity of the plant or when the plant is offline. The potable water backup system will be capable of supplying the full demand.

The goals of the HAWPF include:

- Produce advanced treated recycled water
- Deliver advanced treated recycled water to LAWA for non-potable reuse to reduce potable consumption
- Demonstrate the high level of quality and reliability of this alternative water supply,
- Provide HWRP staff with experience in the operations and maintenance (O&M) of AWT facilities.

The anticipated timeline for the first phase of the HAWPF construction is 2019-2020. The final phase of the HAWPF project is estimated to yield 5,600 AFY (5 mgd) of advanced treated recycled water during normal years, wet years, and dry years if demand materializes.

4.2.1.1 System Upgrades

System upgrades would be required for the implementation of the Hyperion AWP. In particular, approximately 8,000 to 10,000 feet of purple pipe would need to be constructed to delivery water from HWRP to LAWA's LAX.

4.2.1.2 HWRP Upgrades

Additional treatment processes at HWRP would be required for the implementation of the HAWPF. For the HAWPF, the facilities include new AWT facilities, a product water reservoir, product water pump station, and pipeline to the product water reservoir. The AWT processes at HWRP would include fine screens, MBR, RO, UV/AOP, granular activated carbon (GAC), decarbonation, post treatment, and chemical storage and feed facilities, preliminary sizing is summarized in Table 4.24. The HAWPF facility will be built on the site of the unused dissolved air flotation (DAF) facilities (Figure 4.6), and the product water reservoir and pump station will be built in the parking lot next to the Harrington Building. The initial and ultimate layout for these facilities is shown on Figure 4.7 and Figure 4.8.

| Table 4.24 HWRP Upgrades for Advanced Treated Water Delivery to LAX and Scattergood Generating Station Wastewater Facilities Plan One Water LA 2040 Plan | | | |
|-----------------------------------------------------------------------------------------------------------------------------------------------------------------|----------------------------|----------------------------|-----------------|
| Description | Phase 1 (1.5 mgd) | Ultimate (5 mgd) | Units |
| Plant Flow Balance | | | |
| Design Capacity - Production | | | |
| Product Water | 1.5 | 5 | mgd |
| Product Water | 1040 | 3472 | gpm |
| Design Capacity - Production | | | |
| MBR Influent | 1.8 | 6 | mgd |
| RO Influent | 1.76 | 5.88 | mgd |
| AOP Influent | 1.5 | 5 | mgd |
| Recoveries for Unit Processes | | | |
| MBR Waste Activated Sludge Flow | 2 | 2 | % |
| RO Recovery | 85 | 85 | % |
| PE Feed Pump Station | | | |
| Type | Submersible Non-Clog | Submersible Non-Clog | |
| Firm Capacity | 2.4 / 1,680 | 6.0 / 4,200 | mgd/gpm |
| Waste Return Pump Station | | | |
| Type | Submersible Non-Clog | Submersible Non-Clog | |
| Firm Capacity | 2.4 / 1,680 | 6.0 / 4,200 | mgd/gpm |
| Fine Screen | | | |
| Quantity of Screens | 2 + 1 | 3 + 1 | - |
| Type | Internally-Fed Drum Screen | Internally-Fed Drum Screen | - |
| Membrane Bioreactor | | | |
| Pre-Anoxic Basin | | | |
| Number of Basins | 2 | 5 | - |
| Basin Volume, Each | 48000 | 48000 | gal |
| Basin Volume, Each | 6417 | 6417 | ft ³ |
| Aeration Basin | | | |
| Number of Basins | 2 | 5 | - |
| Basin Volume | 184000 | 184000 | gal |
| Basin Volume | 24600 | 24600 | ft ³ |
| HRT, per train (Excluding Recycle Flow) | 3.65 | 3.65 | hours |
| Membrane System | | | |
| System | TBD | TBD | |
| Number of Basins | 2 | 5 | |
| Volume, Each Basin | 60000 | 60000 | |
| Volume, Each Basin | 8020 | 8020 | |
| Break Tank | | | |
| Design Volume | 40849 | 40849 | gal |
| Hydraulic Residence Time | 33 | 10 | min |

| Table 4.24 HWRP Upgrades for Advanced Treated Water Delivery to LAX and Scattergood Generating Station Wastewater Facilities Plan One Water LA 2040 Plan | | | |
|-----------------------------------------------------------------------------------------------------------------------------------------------------------------|---------------------------|---------------------------|---------|
| Description | Phase 1 (1.5 mgd) | Ultimate (5 mgd) | Units |
| Reverse Osmosis | | | |
| Number of Trains | 1 | 3 | - |
| Number of Cartridge Filters | 2 (1 + 1) | 4 (3 + 1) | - |
| RO Trains - Stage 1 | | | |
| Target Average Flux | 12.4 | 12.3 | gfd |
| Membrane Area per Module | 400 | 400 | sq ft |
| RO Trains - Stage 2 | | | |
| Target Average Flux | 12.3 | 12.2 | gfd |
| Membrane Area per Module | 400 | 400 | sq ft |
| GAC | | | |
| Number of GAC Filters | 2 (2 + 0) | 4 (4 + 0) | - |
| Flow per Filter | 521 | 868 | gpm |
| Media Height | 6 | 6 | ft |
| UV/AOP System | | | |
| System | Low Pressure, High Output | Low Pressure, High Output | - |
| Oxidant | NaOCl | NaOCl | - |
| Number of UV Reactors | 2 (1 + 1) | 3 (2 + 1) | - |
| Flow per Reactor | 1042 | 1736 | gpm |
| Decarbonator | | | |
| Type | Packed Tower Aerators | Packed Tower Aerators | - |
| Number of Decarbonators | 1 (1 + 0) | 2 (2 + 0) | - |
| Flow per Decarbonator | 1042 | 1736 | gpm |
| Area per Decarbonator | 50 | 50 | sq ft |
| Product Water Transfer Pump Station | | | |
| Type | Vertical Turbine | Vertical Turbine | |
| Firm Capacity | 2.0 / 1,100 | 5.0 / 3,500 | mgd/gpm |
| Number of Pumps | 2+1 | 3+1 | -- |
| Pump Motor | 20 | 40 | hp |
| Product Water Reservoir | | | |
| Capacity | 1 | 1 | MG |
| Product Water Export Pump Station | | | |
| Type | Vertical Turbine | Vertical Turbine | |
| Firm Capacity | 2.0 / 1,500 | 5.0 / 3,470 | mgd/gpm |
| Number of Pumps | 2 + 1 | 4 + 1 | - |
| Pump Capacity | 750 | 870 | gpm |
| Pump Motor | 40 | 40 | hp |

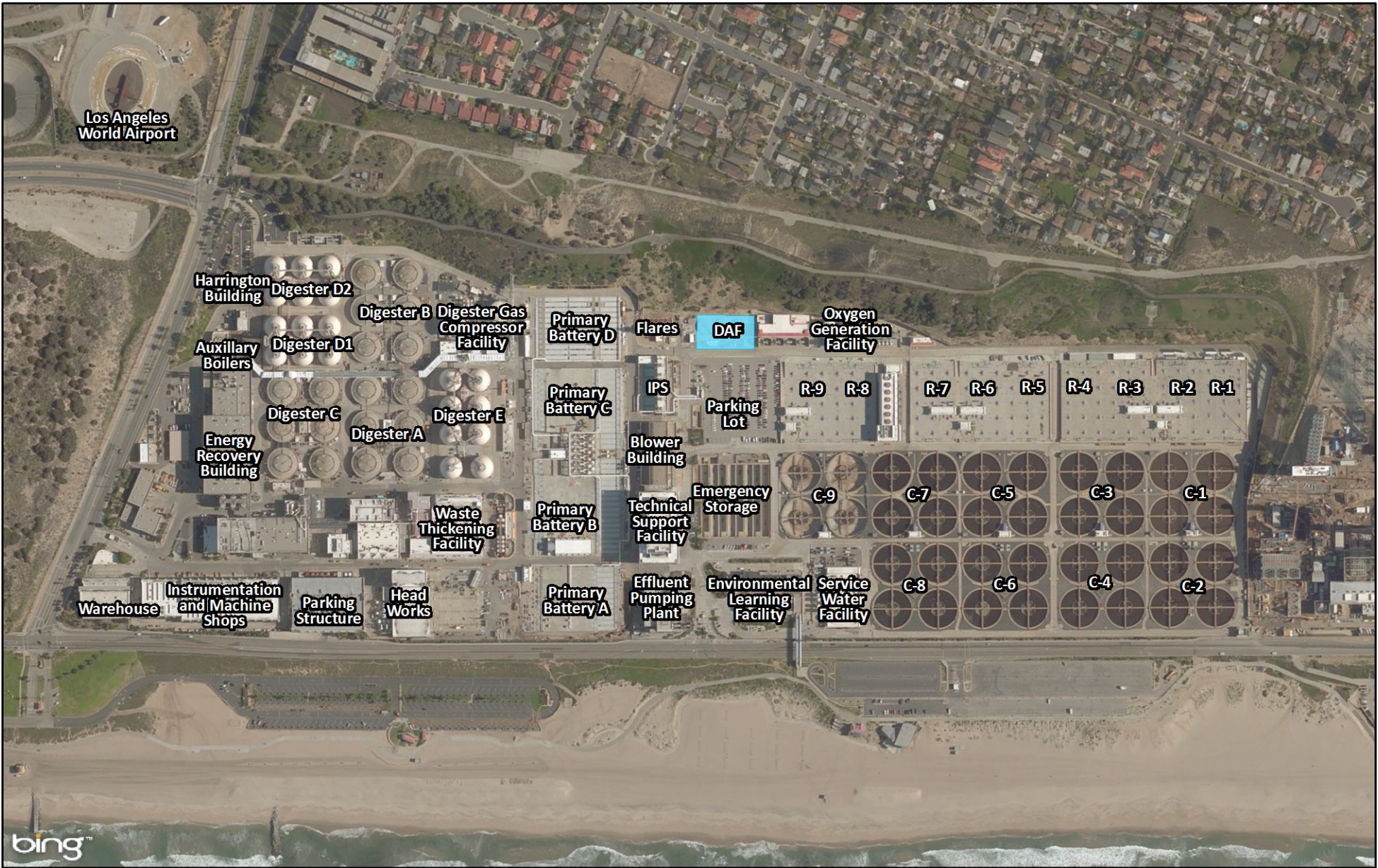

 HAWPF Location

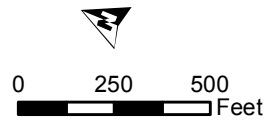

Figure 4.6
Potential Upgrades of HAWPF for
Delivery to LAX and Vicinity
 One Water LA 2040 Plan

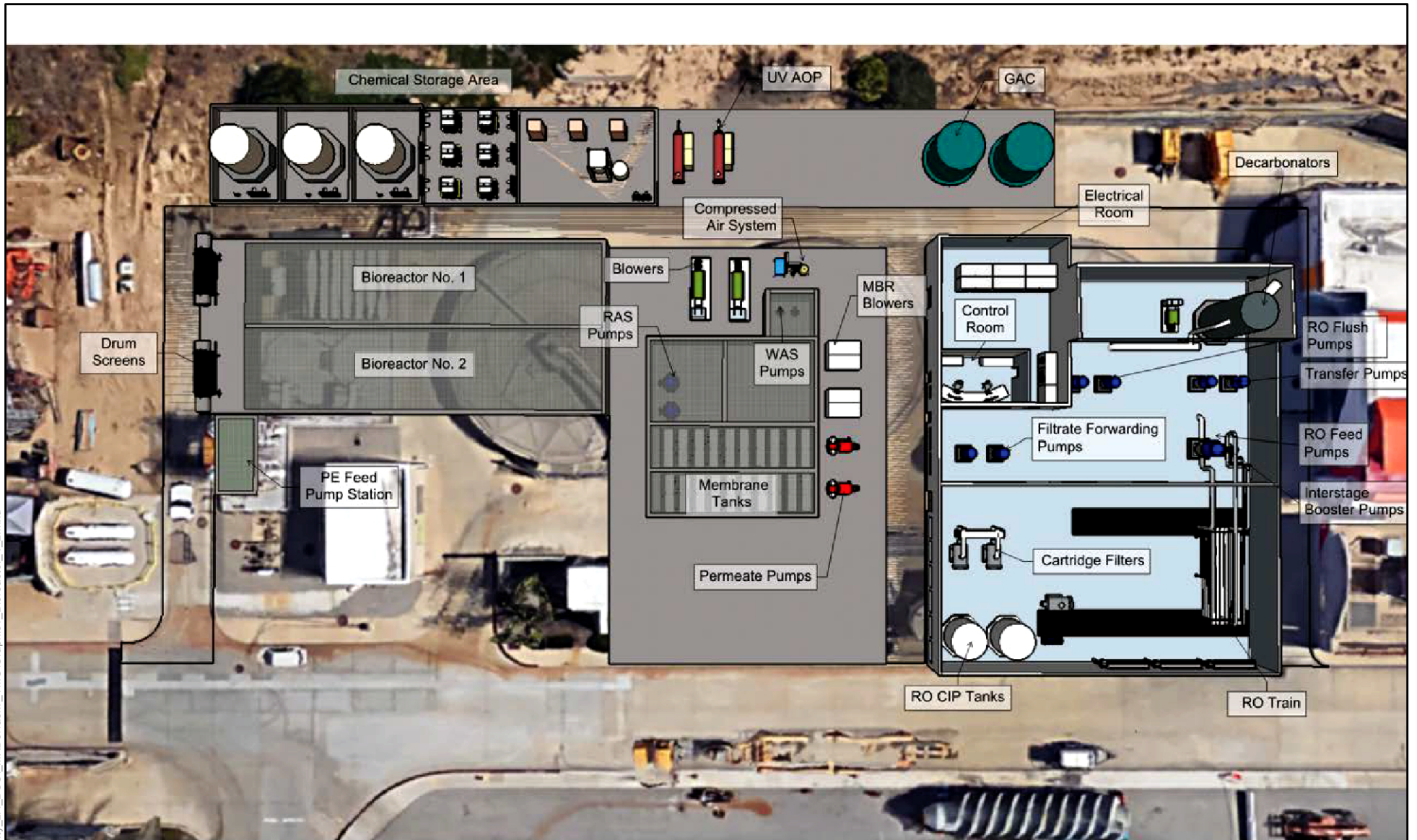

Figure 4.7
HAWPF and Delivery to LAWA
and Vicinity (1.5 mgd)
One Water LA 2040 Plan

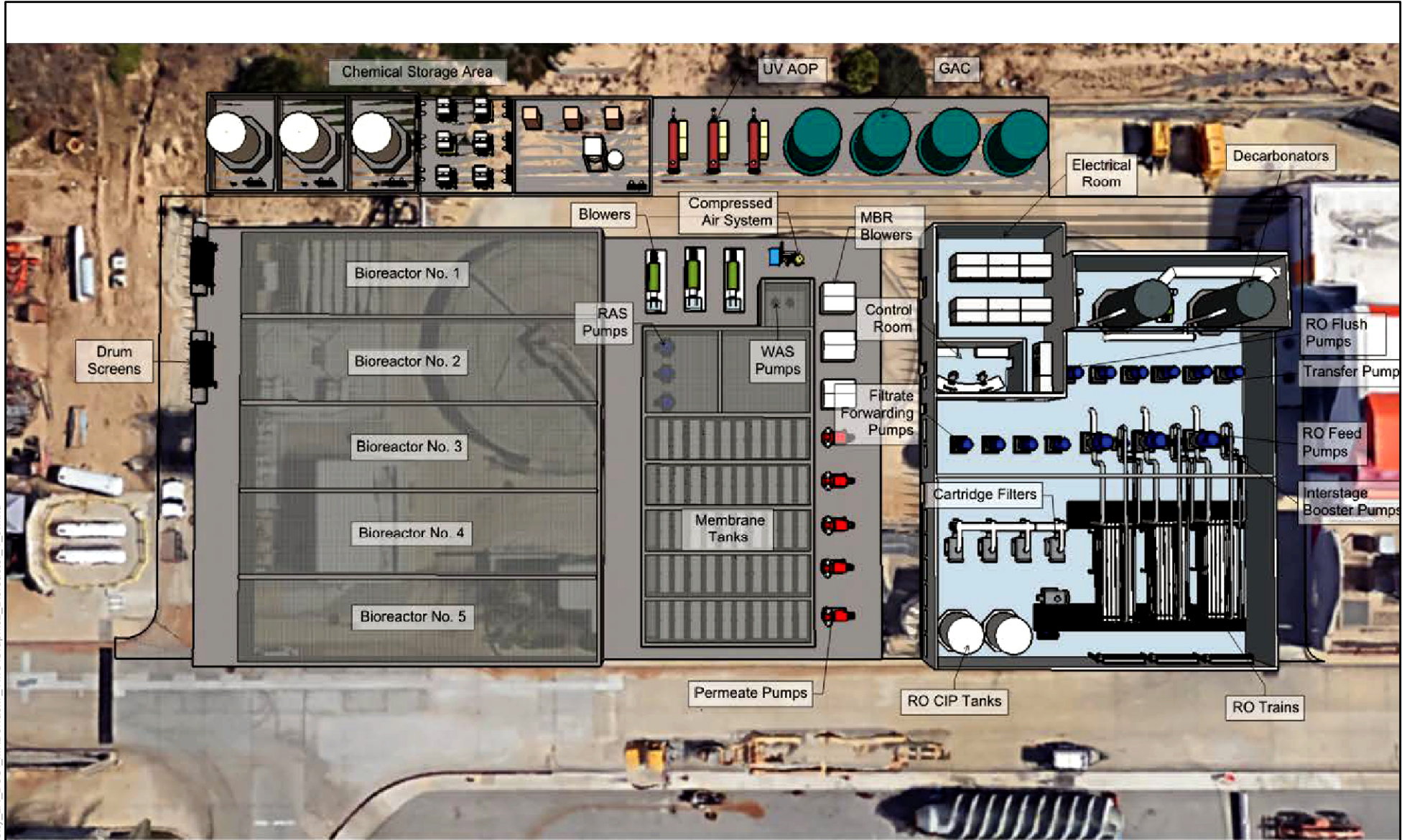

Figure 4.8
HAWPF and Delivery to
LAWA and Vicinity (5 mgd)
 One Water LA 2040 Plan

The northeast portion of the HWRP, near the air gap facility, has been identified as the site for the location of the product water reservoir and pump station for LAWA's LAX. This preferred location was identified based upon proximity to LAWA's LAX, and the minimal impact on plant operations. Product water would be conveyed to the reservoir via a pipeline in the hillside on the east portion of the plant and along 'I Street' prior to the air gap facility. Figure 4.9 identifies the proposed location of the product water reservoir and pump station. SGS has multiple reservoirs capable of storing water from the HAWPF facility, therefore vertical turbine pumps could be provided at the HAWPF facility to convey water to SGS for equalization.

4.2.2 HWRP Delivery Expansion to 70 mgd for WBMWD and LA Harbor Area

HWRP delivers approximately 35 mgd of secondary treated effluent to the WBMWD ECLWRF where secondary effluent is further treated to recycled water standards and beneficially reused. Currently, the pump station that sends water from HWRP to ECLWRF has a firm capacity of 50 mgd and a total capacity of 70 mgd. This project expands the pump station's firm capacity to 83 mgd and total capacity to 98 mgd for HWRP to provide an expected 70 mgd of secondary effluent to ECLWRF. This project will not increase or change the treatment capacity of HWRP. The pump station expansion would be a joint effort between LASAN, WBMWD, and LADWP. The expected timeline for this project is 2020 and this project is estimated to yield 39,200 AFY (35 mgd) of secondary treated effluent during normal years, wet years, and dry years.

4.2.2.1 System Upgrades

The HWRP Delivery Expansion to 70 mgd for WBMWD and Harbor project would not require any significant system improvements. It is anticipated that the current 60-inch pipeline conveying water to WBMWD is large enough to support the additional flow of 70 mgd maximum. Sections of pipe in the WBMWD distribution system may need to be upgraded convey water to existing and new customers.

4.2.2.2 HWRP Upgrades

Significant facility upgrades to HWRP water treatment systems would not be required for the implementation of the HWRP Delivery Expansion to 70 mgd for WBMWD and Harbor project. Facility upgrades would consist primarily of expanding the WBMWD pump station's firm capacity from 50 mgd to 83 mgd and total capacity from 70 mgd to 98 mgd. Figure 4.10 identifies the location of the HWRP-WBMWD Secondary Effluent Pump Station at the HWRP site, while Table 4.25 summarizes the design criteria for the project.



bing™

bing™

 Hyperion Product Water Export Pump Station

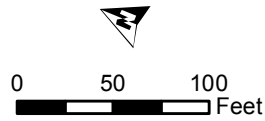
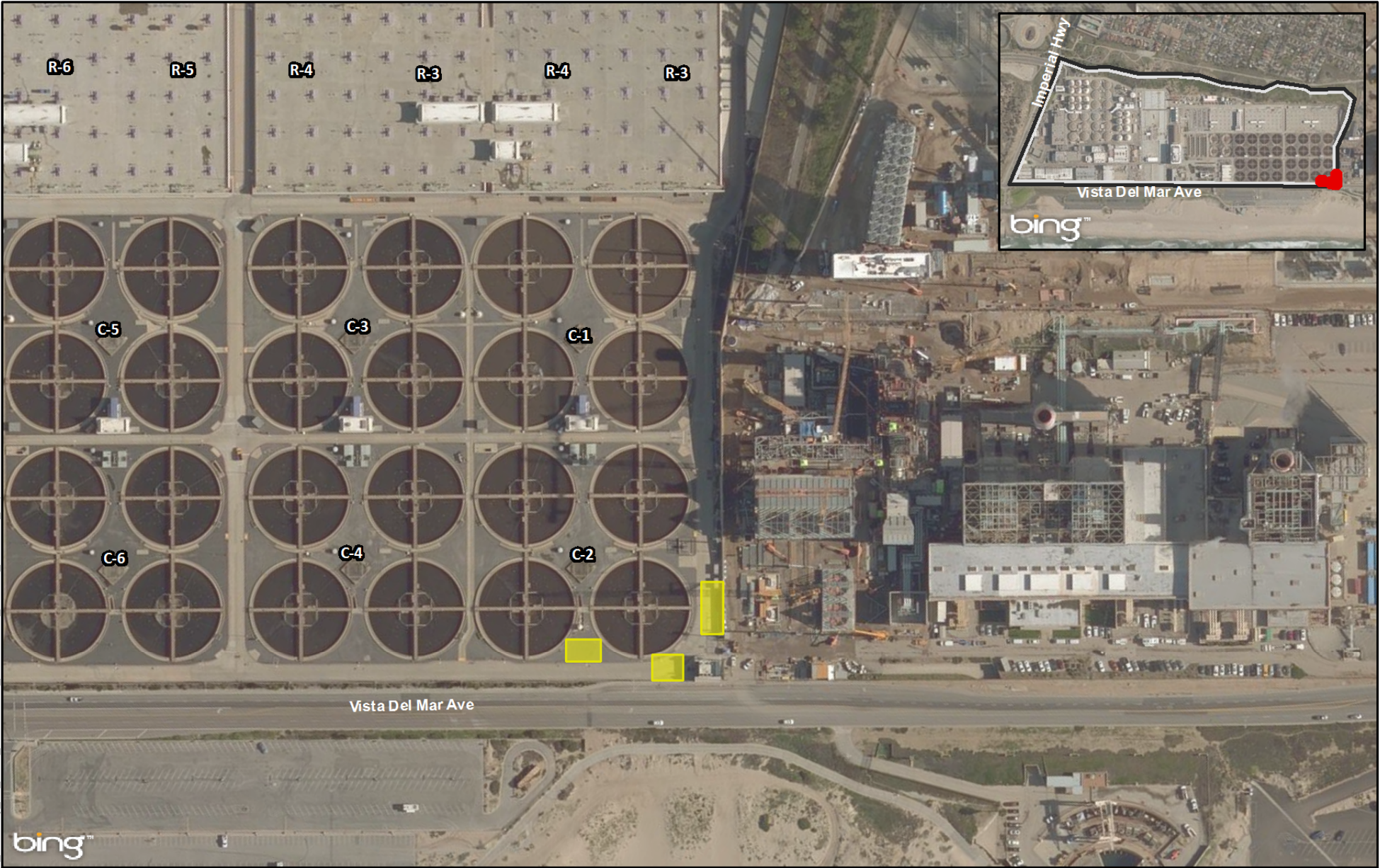

Figure 4.9
HAWPF and Delivery to LAWA
and Vicinity Reservoir Site
One Water LA 2040 Plan

Document Path: \\usrv1s01\GIS\GIS_Jobs\City_LA_BOS_MXD\Task7_TM\GHW\RP_70M\GD_WBMWD_Expansion.mxd



 Hyperion-West Basin Secondary Effluent Pump Station

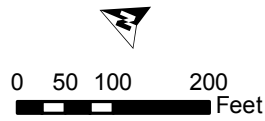

Figure 4.10
Delivery Expansion to 70 mgd
for WBMWD and Harbor
One Water LA 2040 Plan

| Table 4.25 Potential Upgrades for HWRP Delivery Expansion to 70 mgd for WBMWD and LA Harbor Area Wastewater Facilities Plan One Water LA 2040 Plan | | |
|-----------------------------------------------------------------------------------------------------------------------------------------------------------|-----------------|--------------|
| Description | Quantity | Units |
| Secondary Effluent Pumping Station | 42 by 13 | ft |
| Vertical Turbine Pump | 2 | quantity |
| Flow Rate, each | 6400 | gpm |
| Head, each | 181 | ft |
| Power, each | 800 | hp |
| Electrical Building | 10 by 50 | ft |
| Backup Emergency Generator | 18 by 25 | ft |

4.3 FUTURE SYSTEM NEEDS EVALUATION

The previous section discussed HWRP's existing facilities, recent upgrades, and in-progress projects. In order to optimize plant operations and maximize water reuse potential, several future integration opportunities for HWRP have been developed. This section discusses:

- Projected future flows and availability for water reuse
- Future integration opportunities (concept options) for HWRP
- Preferred approach

The preferred approach presented provides for multiple future scenarios based upon the occurrence of defined "trigger" events.

4.3.1 Flow Evaluation

In order to identify which water reuse options could be implemented at HWRP, it is important to understand the flows that may be available for water reuse. This section discusses the current and projected influent and effluent flows.

4.3.1.1 HWRP Influent Flows

The major trunk sewers in the HWRP sewershed area (as discussed in Chapter 3) include the NOS, NORS, NCOS, COS, and CIS. Combined residential, commercial, and industrial flows from these trunk lines to HWRP for treatment are estimated to be approximately 250 mgd on average for 2016. The average flow rate also includes solids residuals and bypassed flows from DCTWRP and LAGWRP.

Dry and Wet Weather Flow Diversion

Implementation of additional dry weather flow diversions could increase flows up to 3.4 mgd to HWRP. Table 4.26 presents future projected wastewater flows for HWRP. Wet weather flow diversions could also bring up to an additional 0.3 mgd to HWRP. Table 4.26 shows the projected influent flows for HWRP, combining dry weather flow diversions and projected wastewater influent.

| Table 4.26 HWRP Projected Wastewater Flows Wastewater Facilities Plan One Water LA 2040 Plan | | | | |
|--------------------------------------------------------------------------------------------------------------------------------------------------|---------------------------------------------------------|----------------|----------------|----------------|
| Flow Source | Projected Wastewater Flows by Year⁽²⁾ | | | |
| | 2016 | 2020 | 2030 | 2040 |
| Wastewater Influent ⁽³⁾ | 250 mgd | 256 mgd | 272 mgd | 280 mgd |
| Future Dry Weather LFDs ⁽¹⁾ | - | - | 3.38 mgd | 3.38 mgd |
| Totals⁽⁴⁾ | 250 mgd | 256 mgd | 275 mgd | 283 mgd |
| Notes: | | | | |
| (1) These LFDs are assumed to be implemented starting in Year 2030. | | | | |
| (2) mgd = million gallons per day | | | | |
| (3) Wastewater Influent values reflect Normal Year hydrological conditions. Additional details of these projected flow values are found in TM2.1 | | | | |
| (4) Flows are rounded to the nearest mgd. | | | | |

4.3.1.2 HWRP Planned or Potential Water Reuse Projects

HWRP currently produces secondary effluent for in-plant usages and conveys an average of 35 mgd to WBMWD for further treatment and beneficial water reuse. However, new planned treatment facilities at HWRP will allow for additional potential water reuse of flows. The current In-Progress Project, HAWPF Delivery to LAX and SGS, will include advanced water treatment facilities yielding recycled water for NPR at Los Angeles World Airports (LAWA) and potentially more water supply for additional NPR and potential potable reuse demands. The other In-Progress Project (HWRP Delivery Expansion to 70 mgd (capacity) for WBMWD and Harbor) will increase the amount of tertiary recycled water delivered to WBMWD for water reuse.

4.3.1.3 Concept Option Flow Assumptions

The concept options consist of various potable reuse options. The estimated yield associated with the potable reuse options are dependent on the capabilities of the groundwater basin aquifer used for injection and the quantity of HWRP flows available for water reuse. Due to these considerations the estimated available flow for additional water reuse is limited to roughly 85 mgd or 95,000 AFY. This is substantially less than the projected 2040 flow of 283 mgd because a portion of these flows are already allocated, as indicated in Table 4.27 and Figure 4.11.

| Table 4.27 HWRP Flow Assumptions Wastewater Facilities Plan One Water LA 2040 Plan | |
|---------------------------------------------------------------------------------------------------------------------------------------------------------------------------------------------------------------------------------------|--------------------|
| Flow Component | Flow (mgd) |
| HWRP 2040 Project Influent Flow | 283 |
| In-Plant Uses | -36 ⁽¹⁾ |
| Existing Delivery to West Basin | -35 |
| Expanded Delivery to West Basin | -35 |
| Hyperion AWPf (HAWPF) | -1.5 up to -5 |
| Expanded DCTWRP Water Reuse | -34 |
| Expanded LAGWRP Water Reuse | -3 |
| Potential Rancho Park WRF | -5 |
| Brine Loss due to HAWPF (LAWA) | -0.2 up to -0.75 |
| Brine Loss due to potential Advanced Water Purification Facility | -20 ⁽²⁾ |
| Range of Available Flows for Water Reuse | 109-133 |
| Notes: (1) 25 mgd is used once through cooling at the HBEF. 11 mgd is used for other in-plant uses. 36 mgd non-recoverable at this time for recycling. (2) Based on assumed capacity of 85 mgd per Concept Option #13 | |

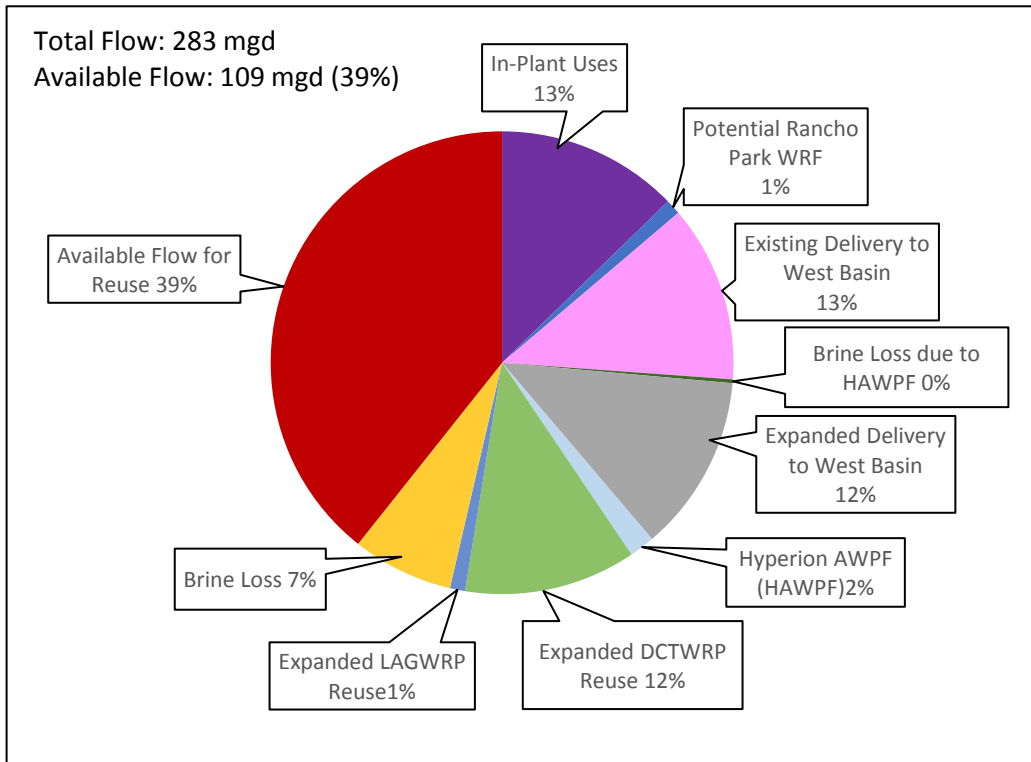

Figure 4.11 Estimated Flow Availability for Water Reuse from HWRP (2040 Projection)

A conservative estimate of 85 mgd was used to account for the remaining flows available at HWRP for water reuse. This flow may vary due to conservation, and the amount of flow bypassed from the upstream plants. This value was used for the sizing of facilities and equipment required for each concept option as discussed in greater detail in Volume 5 and Appendix C.

4.3.2 Concept Options Development

The preliminary list of concept options that support a locally sourced water supply was developed through workshops that solicited ideas and input from a workgroup as well as community stakeholders. This workgroup included contributors from an array of communities, LASAN, LADWP, other City Bureaus and Departments and select technical advisors. These ideas resulted in the development of concept options within the 2040 planning horizon. Concept options represent new concepts that have not been previously evaluated by the City.

With this methodology, a list of 27 concept options was developed for the entire system. Of these 27 concept options, seven concept options were related to HWRP. Determination of Hyperion's future system needs were based on previous master plans, planning documents, discussions with City staff, and brainstorming sessions. Specifics related to these concept options can be found in Appendix C. The concept options are preliminary in nature and are not a commitment to level or quantity of treatment. Table 4.28 shows the concept options associated with HWRP, including the normal year estimated yield and associated capital costs.

As shown in Table 4.28, the concept options for HWRP involved one of the three water reuse strategies:

- Potable reuse with groundwater augmentation - Projects that would spread (infiltrate) or directly inject recycled water into a groundwater basin that could be used as potable water after extraction and further treatment.
- Potable reuse with raw water augmentation prior to delivery - Projects that would deliver advanced treated recycled water (purified water) to a conventional water treatment plant before distributing into a potable water system.
- Potable reuse with treated water augmentation prior to delivery into the potable water distribution system - Projects that would deliver advanced treated recycled water (purified water) directly to a potable water system.

While there are differences between the options in terms of capacity, delivery location, and ultimate use, all require similar levels of advanced treatment.

| Table 4.28 HWRP Concept Options Wastewater Facilities Plan One Water LA 2040 Plan | | | | | |
|----------------------------------------------------------------------------------------------------------------------------------------------------------------------------------------------------------------------|-------------------------------------------------------|----------------------------------------------------|--------------------------------------|-----------------------------------------|--------------------------|
| Concept Option # | Title | Strategy | Estimated Yield (Normal Year) | Capital Cost (\$M)⁽¹⁾ | Unit Cost (\$/AF) |
| 10 | Hyperion WRP to West Coast Basin Injection Wells | Potable Reuse with Groundwater Augmentation | 20,000 AFY (17 mgd) | \$900 | \$3,200 |
| 11 | Hyperion WRP to Central Basin Injection Wells | Potable Reuse with Groundwater Augmentation | 75,000 AFY (70 mgd) | \$3,300 | \$2,700 |
| 13 | MBR at Hyperion WRP to Regional System | Potable Reuse with Groundwater Augmentation | 95,000 AFY (85 mgd) | \$900 | \$1,500 |
| 14 | Hyperion WRP to San Fernando Basin Injection Wells | Potable Reuse with Groundwater Augmentation | 20,000 AFY (18 mgd) | \$680 | \$2,400 |
| 18 | Hyperion WRP to LADWP Distribution System | Potable Reuse with Treated Water Augmentation | 95,000 AFY (85 mgd) | \$2,800 | \$2,100 |
| 19 | Hyperion WRP to Headworks Reservoir | Potable Reuse with Treated Water Augmentation | 95,000 AFY (85 mgd) | \$3,200 | \$2,400 |
| 20 | Hyperion WRP to Los Angeles Aqueduct Filtration Plant | Potable Reuse with Raw Water Augmentation | 95,000 AFY (85 mgd) | \$3,600 | \$2,600 |
| Note: | | | | | |
| (1) Total Concept Option cost includes a variety of project components including treatment facilities, conveyance, and injection and extraction facilities. Not all costs pertain to the Wastewater Facilities Plan. | | | | | |
| (2) Concept Option #12 was determined to have a fatal flaw resulting from 1) a lack of capacity in the existing Rio Hondo Spreading Grounds and 2) a lack of vacant land to construct new spreading basins. | | | | | |
| (3) Bold indicates a Priority A Concept Option | | | | | |

4.3.3 Preferred Approach

As part of the WWFP development, each of the concept options listed above was reviewed to identify improvements that would need to be implemented at the plant as well as system changes to convey that product water. This analysis included preliminary sizing of treatment process modifications, location of the processes, and preliminary cost estimates. Based on the overall concept score, cost estimates, and portfolio evaluation results, the concept options were prioritized. As the flows from each plant can only be utilized once, it is important to identify what the most beneficial method of water reuse. However, implementing many concept options are dependent upon the occurrence certain "triggers" events, such as regulatory changes or new institutional arrangements.

As a result, the highest scoring concept option may not be viable depending on which triggers may or may not occur in the future. To guide the City with prioritization and the decision-making process related to these future water reuse options, a trigger-based implementation strategy was developed. Figure 4.12 graphically depicts the triggers and the priority of implementation. The most preferred concept option is indicated as "Priority A", while the next best concept option is identified as "Priority B" and third best as "Priorities C & D".

The most critical trigger to implement the Priority A Concept Option #13 (MBR at HWRP to Regional System) is establishing an institutional agreement with a regional project partner, such as Metropolitan Water District (MWD), the Water Replenishment District (WRD), LACSD, and/or WBMWD. If such an agreement does not materialize, the Priority B and C options could also be considered.

The most critical trigger for the Priority B Concept Option #18 (HWRP to LADWP Distribution System) is adopting potable reuse with treated water augmentation regulations that would allow this type of water reuse practice. If the potable regulations are not accepted within a desired timeframe, or if the City prefers a more conventional form of water reuse, the third-best potable reuse options from HWRP are Concept Options #10 and #11. These options consist of groundwater augmentation in the West Coast and Central Basin, respectively. Both options require an institutional agreement with WRD, who acts as the Watermaster for these two groundwater basins. In case such an agreement does not materialize and potable reuse regulation are not approved, it is recommended to postpone the implementation of a large scale potable reuse project from HWRP, which is indicated as "No Change" on Figure 4.12.

Hyperion Water Reclamation Plant

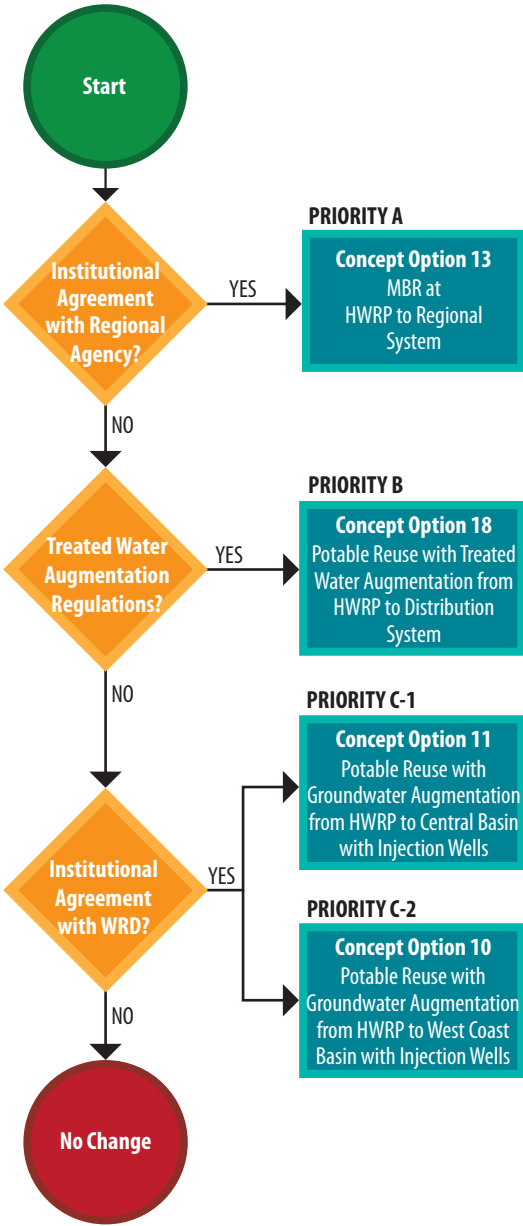

LEGEND & ACRONYMS

- ◆ Trigger
- Concept Option
- Flow Management Option

| | |
|--------|-----------------------------------------------------|
| DCTWRP | Donald C. Tillman Water Reclamation Plant |
| GWR | Groundwater Replenishment Project |
| HWRP | Hyperion Water Reclamation Plant |
| LAGWRP | LA-Glendale Water Reclamation Plant |
| RWQCB | Regional Water Quality Control Board |
| TIWRP | Terminal Island Water Reclamation Plant |
| WRD | Water Replenishment District of Southern California |

Disclaimer: At each trigger (decision point), evaluate all triggers and concept option priorities to consider changed circumstances in the future.

Figure 4.12
Trigger-Based Implementation Strategy for HWRP
One Water LA 2040 Plan
Summary Report

4.3.4 Concept Option #13 (MBR at HWRP to Regional System)

HWRP has the potential capacity to supply 78,000 to 95,000 AFY (70 - 85 mgd), as indicated in the previous flow evaluation section, of MBR effluent for distribution to other regional systems. If MBR treatment is implemented at HWRP, the amount of flow delivered to other regional systems is dependent upon the amount of flow that HWRP dedicates to projects that take precedent. Depending on the regional system, this potential potable reuse concept may include an MBR facility a pump station, conveyance, recovery via extraction wells, connection to a potable distribution system, and new production facilities to recover and convey recharged water to the other regional system. Figure 4.13 shows MBR effluent conveyed to Regional Facility and the brine from MBR treatment discharged via the Hyperion outfall.

The estimated timeline for the MBR at HWRP to Regional System concept is 2030-2040 and the concept may yield up to 95,000 AFY (85 mgd) of potable water during for normal years, wet years, and dry years.

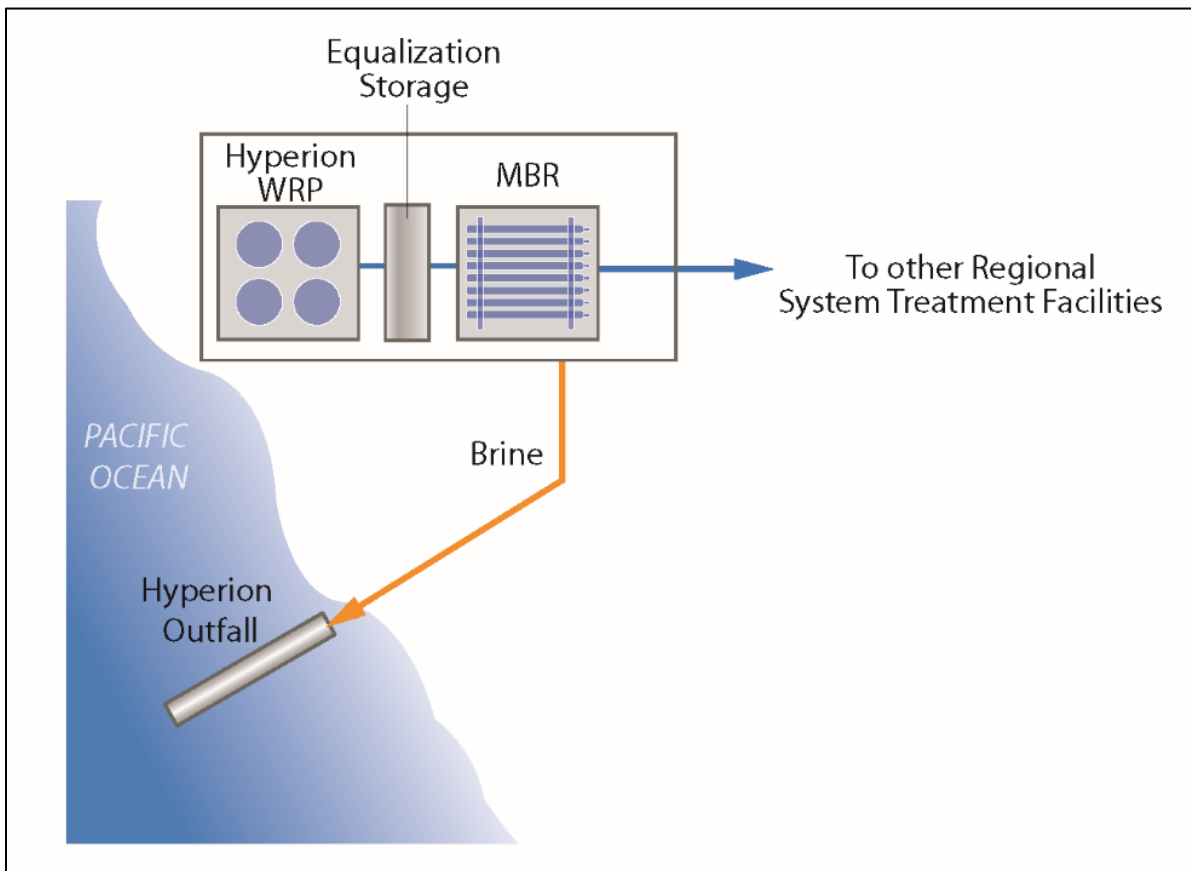

Figure 4.13 Process Flow Schematic for Concept Option #13 (MBR at HWRP to Regional System)

4.3.4.1 System Upgrades

System upgrades may be required for the implementation of the Concept Option #13 (MBR at HWRP to Regional System). This concept could require new recharge and production wells, and a large amount of conveyance. Details of this concept option, including system infrastructure requirements, would need to be developed should this concept option be chosen to be implemented.

4.3.4.2 HWRP Upgrades

Facility upgrades at HWRP may be required for the implementation of Concept Option #13 (MBR at HWRP to Regional System). In particular, facility upgrades could include 25 MG of equalization and 85 mgd of MBR. The sizing of the equalization facilities may require a deeper partially buried tank. Potential design criteria for the HWRP upgrades is summarized in Table 4.29. Figure 4.14 depicts potential AWPf locations at HWRP.

| Table 4.29 Potential Upgrades MBR at HWRP to Regional System Wastewater Facilities Plan One Water LA 2040 Plan | | |
|-------------------------------------------------------------------------------------------------------------------------------|-----------------|--------------|
| Description | Quantity | Units |
| Primary Effluent (Feedwater) | 89 | mgd |
| Wastewater Equalization | 25.0 | MG |
| Wastewater Equalization Footprint | 75,000 | sq ft |
| Wastewater Equalization Hydraulic Retention Time | 6.71 | hr. |
| Bioreactors to Retrofit | 85 | mgd |
| Bioreactor Trains to Retrofit | 8 | quantity |
| Membrane Separation Footprint | 45,000 | sq ft |
| Membrane Permeate Flow | 85 | mgd |
| WAS Flow | 4 | mgd |
| Pump Station ⁽¹⁾ | 13,000 | hp |
| Pump Station Footprint | 10,000 | sq ft |
| Secondary Clarifiers Demolition | 55,000 | sq ft |
| Clarifier Modules to Replace (4 per Module) | 1 | quantity |
| Assumptions: | | |
| (1) HP calculations assumed an elevation of 700 ft and an LF of 60,000 | | |
| (2) Wastewater Equalization and Product Water Equalization Tanks are assumed to be 45 ft deep | | |
| (3) Primary influent is assumed at 5% solids | | |
| (4) Footprint for MBR Facilities is based upon Hyperion Reuse Feasibility Study (MWH, May 2016) | | |
| (5) Footprint for Pump Station is based upon Hyperion West Basin Secondary Effluent Pump Station (Bid Documents, April 2017) | | |

Concept Option #13 (MBR at HWRP to Regional System) is a Priority A concept option. The key benefits associated with this concept option consist of:

- Maximizing HWRP's flows for reuse reducing discharge to the ocean.
- Promotes collaboration with regional partners
- Delivers water to a regional system for reuse such as recharge into a groundwater basin that may be extracted for potable reuse and sold to water retailers at full service rates.

Moreover, this concept option helps fulfill the following One Water key objectives and guiding principles:

- Implement, monitor, and maintain a reliable wastewater system.
- Improve local water supplies reliability.
- Integrate management of water resources & policies.
- Increase climate resilience.

Document Path: \\usinv1s01\GIS\GIS_Jobs\City_LA_BOS_MXD\Task7_TM\G\HWRP_PPEB_Metropolitan_20170914.mxd



- Proposed Facility
- Fine Screen
- Hyperion Recycled Water Pump Station
- MBR

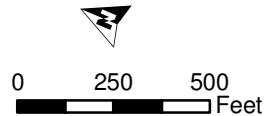

Figure 4.14
Potential Upgrades
for Concept Option #13
(MBR at HWRP to Regional
System)
 One Water LA 2040 Plan

4.4 CLIMATE RISK AND RESILIENCE ASSESSMENT

Climate change is projected to impact the City's wastewater and stormwater systems in a variety of ways. The wastewater systems consist of sewer systems, sewage pumping facilities, wastewater treatment facilities and water reclamation facilities. Changes in temperature, precipitation, and sea levels will affect the physical plant and operational vulnerabilities of these facilities and operations.

A climate risk and resilience assessment was performed consisting of scenario development, screening analyses, site visits, risk analyses, and adaptation planning concurrent with meetings with LASAN staff. Current and potential future climate conditions were incorporated into the assessment and development of recommendations. Subsequently, practical improvements for the WRPs were identified to mitigate these risks.

A detailed description of the climate risk assessment of HWRP is included in Chapter 10, while the findings and recommendations are summarized in this Section.

HWRP is located along the Pacific coast and adjacent to several flood hazard zones. Climate change conditions of increasing temperatures, Sea Level Rise (SLR), and changes in rainfall may affect power supply, coastal flooding, tsunami and landslide hazards, as well as treatment processes. Assessments were performed on the flooding, power failure and erosion risks associated with climate change to identify resilience improvements that address these risks. Overall the current and future climate hazards risk assessment for HWRP is low upon the implementation of the planned slope stabilization and planning recommendations. The capital and non-capital facility planning recommendations with conceptual construction costs for HWRP are as follows:

- Enhance slope stabilization and lengthen existing retaining wall approximately 1,100 feet to complete wall along eastern edge of facility - approximately \$600,000 conceptual construction cost.
- Perform a structural analysis of Vista Del Mar with Los Angeles County to determine structural stability of roadway during future flood and seismic/tsunami conditions.
- Evaluate tsunami impacts to HWRP hydraulics including tsunami magnitude needed to damage outfalls or hydraulically block effluent discharge.
- Monitor influent TDS and consider performing a cost benefit analysis of lining pipes versus treatment to mitigate higher influent TDS concentrations for water reuse purposes.

No additional capital or non-capital resilience improvements are recommended for HWRP at this point in time. Other climate change considerations may be assessed in the future.

4.5 HWRP ADAPTIVE CIP

A comprehensive wastewater facilities Capital Improvement Plan (CIP) has been developed for all four WRPs and the collection system, located in Chapter 11 of this Volume. The purpose of this section is to summarize the capital improvement projects identified for HWRP. The sources used to develop the CIP include the Los Angeles Bureau of Engineering (LABOE) Uniform Project Reporting System (UPRS), LASAN Wastewater Capital Improvement Plan (WCIP), LADWP 2015 UWMP, and concept options developed as part of the One Water LA 2040 Plan.

The development of the HWRP Adaptive CIP compiles the projects previously discussed in this chapter with the WCIP developed by the City. The projects for HWRP are classified as follows:

- In-Progress Projects
- Future integration opportunities (concept options)
- Estimated and Projected CIP

The costs for the Estimated and Projected CIP are presented by category and phase, defined in Table 4.30. Project costs are then summarized and escalated based upon implementation schedule. The CIP for HWRP represents one component of the overall WWFP Adaptive CIP. The details for cost estimating methodology are summarized in Chapter 11.

| Table 4.30 CIP Terms and Definition Wastewater Facilities Plan One Water LA 2040 Plan | | |
|------------------------------------------------------------------------------------------------------|--------------------------------------------|--------------------------------------------------------------------------------------------------------------------------------------------------------------------------------------------------------------------------------------------------------|
| Group | Term | Definition |
| Category | Capital Project from WCIP | These projects were previously identified in the WCIP. These projects include new construction, expansion, or renovation that helps maintain or improve a City facility or infrastructure that may be funded by the Capital Budget. |
| | R&R from WCIP | These are projects identified in the WCIP. These projects are needed for the continued operation of the facility in its present form. |
| | Climate Resiliency Projects ⁽¹⁾ | These are projects developed as part of the Plan and identified in Volume 6 Climate Risk and Resilience Assessment for Wastewater and Stormwater Infrastructure. These projects are needed to adapt to environmental conditions due to climate change. |
| | Projected Capital Projects | These are projects not identified in the WCIP and are projected as part of the WWFP in collaboration from City staff. These projects include new construction, |

| Table 4.30 CIP Terms and Definition Wastewater Facilities Plan One Water LA 2040 Plan | | |
|------------------------------------------------------------------------------------------------------|------------------------|----------------------------------------------------------------------------------------------------------------------------------------------------------------------------------------------------------------------------------------------------------------------------------------|
| | | expansion, or renovation that helps maintain or improve a City facility or infrastructure that may be funded by the Capital Budget. Project costs were estimated using a methodology described in Chapter 11. |
| | Projected R&R Projects | These are projects not identified in the WCIP and are projected as part of the WWFP in collaboration with City staff. These projects may be needed for the continued operation of the facility in its present form. These projects were estimated using the methodology in Chapter 11. |
| Phase ⁽²⁾ | Near-Term | Projects that are planned to be constructed between 2018 to 2020 |
| | Mid-Term | Projects that are planned to be constructed between 2021 and 2030 |
| | Long-Term | Projects that are planned to be constructed between 2031 and 2040 |
| <u>Note:</u> | | |
| (1) Climate resiliency projects were identified based on the analysis described in Volume 6. | | |
| (2) The phases were determined by LASAN and LADWP management for all projects included in the Plan. | | |

The following sections use the sources, methodologies, terms and definitions to present the In-Progress Projects, future integration opportunities and Estimated and Projected CIP for the HWRP Adaptive CIP.

4.5.1 HWRP In-Progress Projects

Table 4.31 summarizes the In-Progress Projects, estimated capital costs, projected construction completion, and resulting phase for HWRP. Additional details of the In-Progress Projects were previously summarized in Section 4.2.

| Table 4.31 Summary of In-Progress Project Estimated Costs Wastewater Facilities Plan One Water LA 2040 Plan | | | |
|----------------------------------------------------------------------------------------------------------------------------|----------------------------------------------------------|----------------------|--------------|
| In-Progress Projects | Estimated Capital Cost Estimate (\$2017) Millions | Year Complete | Phase |
| Advanced Treated Recycled Water Delivery to LAX and SGS | \$38 ⁽¹⁾ | 2019-2020 | Near |
| HWRP Delivery Expansion to 70 mgd for WBMWD and LA Harbor Area | \$15.6 ⁽²⁾ | 2020 | Near |

| Table 4.31 Summary of In-Progress Project Estimated Costs Wastewater Facilities Plan One Water LA 2040 Plan | | | |
|------------------------------------------------------------------------------------------------------------------------------------------------------------------------------------------------------------------------------------------------------------------------------|------------------------------------------------------------------|--------------------------|--------------|
| In-Progress Projects | Estimated Capital Cost Estimate (\$2017) Millions | Year Complete | Phase |
| Total | | \$145.6 | |
| Notes: | | | |
| (1) Cost of phase 1 of this project is estimated at \$38 million, scheduled to occur in the near-term. Expansion of additional 3.5 mgd (product water) could occur in the mid-term, for an estimated capital cost of \$92 million for a total capital cost of \$130 million. | | | |
| (2) The estimated capital cost is for the expansion of the pump station and does not include WBMWD's costs. An additional cost of \$400 million could be incurred in the future should 70 mgd of MBR treatment be installed at HWRP. | | | |

4.5.2 HWRP Concept Options

The concept options and priority identification for HWRP are summarized in Section 4.3.2. Concept Option #13 (MBR at HWRP to Regional System) was identified as the Priority A concept option. Recognizing that implementation of this concept option could include changes to HWRP and system changes outside of the plant, only the plant-related costs are included in the HWRP Adaptive CIP and the Wastewater Facilities Adaptive CIP. The plant-related estimated cost for Concept Option #13 in 2017 dollars is \$900 million.

4.5.3 HWRP Estimated and Projected CIP

The Estimated and Projected CIP is based on the WCIP, plus the climate risk analysis. In areas lacking any estimate of costs, a set of assumptions are used to develop projected costs for annual capital and replacement and rehabilitation projects. Details of these assumptions are summarized in Chapter 11. The Estimated and Projected CIPs for HWRP are provided in Table 4.32 and Figure 4.15. The details of the projects included in the table can be found in Appendix H.

| Table 4.32 HWRP Estimated and Projected CIP Wastewater Facilities Plan One Water LA 2040 Plan | | | |
|--------------------------------------------------------------------------------------------------------------|-----------------------------|------------------------------------|------------------------------------|
| | Category | Total (\$2017) Millions | Total (\$2017) Millions |
| Near-Term | Capital Project from WCIP | \$20 | \$106 |
| | R&R from WCIP | \$85 | |
| | Climate Resiliency Projects | \$0.6 | |
| | Projected Capital Projects | - | |
| | Projected R&R Projects | - | |

| Table 4.32 HWRP Estimated and Projected CIP Wastewater Facilities Plan One Water LA 2040 Plan | | | |
|------------------------------------------------------------------------------------------------------|-----------------------------|--------------------------------|--------------------------------|
| | Category | Total (\$2017) Millions | Total (\$2017) Millions |
| Mid-Term | Capital Project from WCIP | \$31 | \$116 |
| | R&R from WCIP | \$85 | |
| | Climate Resiliency Projects | - | |
| | Projected Capital Projects | - | |
| | Projected R&R Projects | - | |
| Long-Term | Capital Project from WCIP | - | \$1,280 |
| | R&R from WCIP | - | |
| | Climate Resiliency Projects | - | |
| | Projected Capital Projects | \$920 | |
| | Projected R&R Projects | \$360 | |
| Total | | | \$1,502 |

Table 4.32 shows that the Estimated and Projected CIP cost for the near-term and mid-term are similar. The majority of the Estimated and Projected CIP costs are anticipated to occur in the long-term phase. The near- and mid-term phases use the project cost estimates identified in the WCIP, whereas projections were used for the long-term phase. These projections are to account for future, but undefined costs that may occur at HWRP. The same information is shown graphically on Figure 4.15.

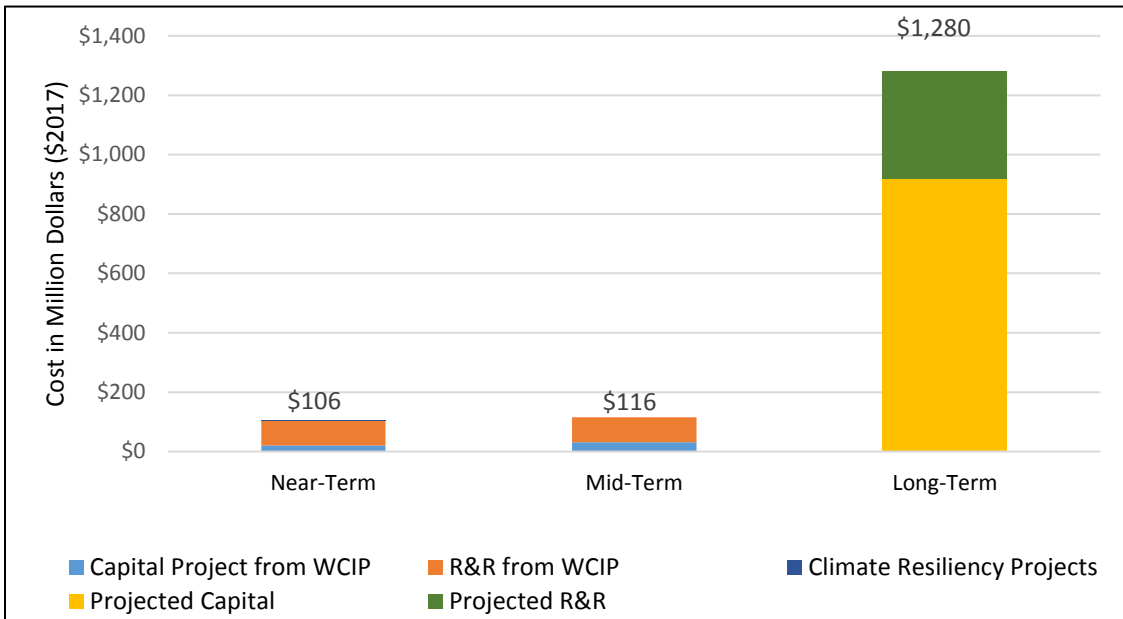

Figure 4.15 Summary of HWRP Estimated and Projected CIP Costs

The CIP for HWRP earmarks roughly the same amount in the near-term and mid-term, as seen in Table 4.32 and on Figure 4.15. Both the near-term and the mid-term consist primarily of replacement and rehabilitation projects, with smaller amount of capital and climate resiliency projects. The long-term phase consists of significantly more projected capital and replacement and rehabilitation costs. The Estimated and Projected CIP costs summarized in Table 4.32 total \$1,502 million which translates to an average cost of approximately \$35.3 million per year from 2018 to 2020, \$11.6 million per year from 2021 to 2030, and \$128 million per year from 2031 to 2040.

Figure 4.16 presents the same Estimated and Projected CIP information as Figure 4.15 but is organized by percent allocated to each category. The Projected Capital Project category is the largest of the five, at 61% of the total Estimated and Projected CIP cost.

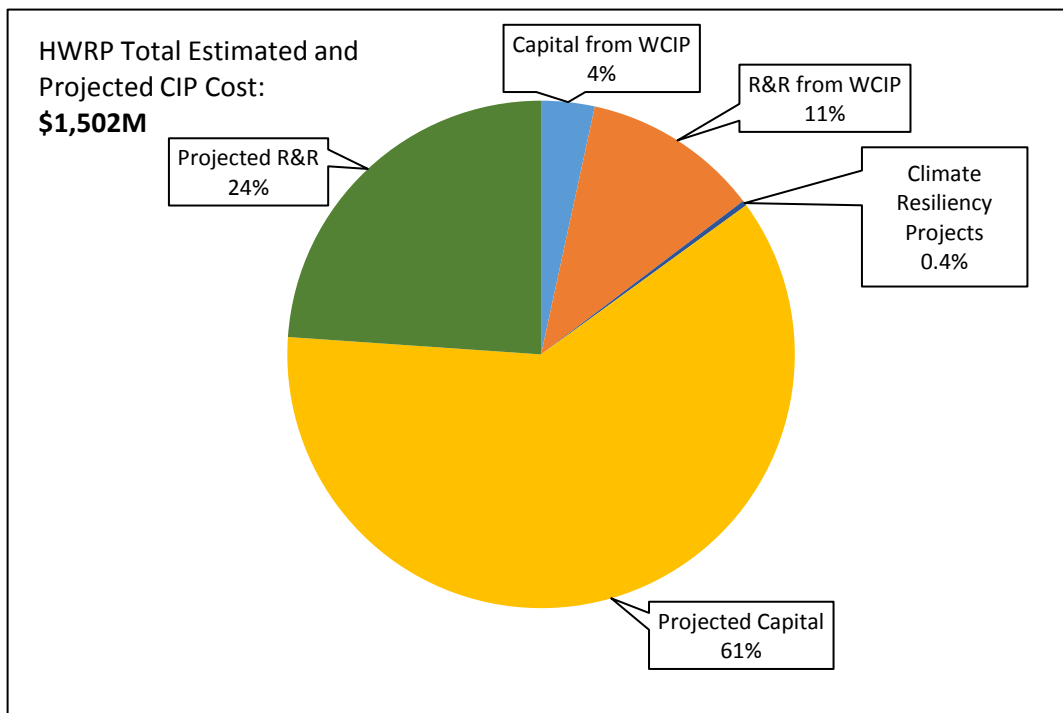

Figure 4.16 HWRP Estimated and Projected CIP Costs by Category

4.5.4 HWRP Adaptive CIP Summary

The combination of the In-Progress Projects, future integration opportunities, and Estimated and Projected CIP serve as the basis for the HWRP portion of the WWFP Adaptive CIP. These three sources of projects are summarized in 2017 dollars in Table 4.33.

| Table 4.33 HWRP Adaptive CIP Summary 2017 (\$M) Wastewater Facilities Plan One Water LA 2040 Plan | | | | |
|------------------------------------------------------------------------------------------------------------------------------------------------------------------------------------------------------------------------------------------------------------------------------|-----------------------------------|----------------------------------|-----------------------------------|----------------|
| Category | Near-term (2018-2020) (\$M) | Mid-term (2021-2030) (\$M) | Long-term (2031-2040) (\$M) | Total (\$M) |
| In Progress Projects | | | | |
| Advanced Treated Recycled Water Delivery to LAX and Scattergood Generating Station | \$38 ⁽¹⁾ | \$92 | \$0 | \$130 |
| HWRP Delivery Expansion to 70 mgd for WBMWD and LA Harbor Area | \$15.6 ⁽²⁾ | \$0 | \$0 | \$15.6 |
| Subtotal⁽¹⁾ | \$53.6 | \$92 | \$0 | \$146 |
| Estimated and Projected CIP | | | | |
| Capital Project from WCIP | \$20 | \$31 | - | \$51 |
| R&R from WCIP | \$85 | \$85 | - | \$170 |
| Climate Resiliency Projects | \$0.6 | - | - | \$0.6 |
| Projected CIP Projects | - | - | \$920 | \$920 |
| Projected R&R Projects | - | - | \$360 | \$360 |
| Subtotal⁽¹⁾ | \$106 | \$116 | \$1,280 | \$1,502 |
| Future Integration Opportunities (WWFP Cost Element) | | | | |
| Concept Option #13 (MBR at Hyperion WRP to Regional System) | \$0 | \$0 | \$900 | \$900 |
| Subtotal⁽¹⁾ | \$0 | \$0 | \$900 | \$900 |
| Total | \$159 | \$208 | \$2,180 | \$2,548 |
| Note: | | | | |
| (1) Cost of phase 1 of this project is estimated at \$38 million, scheduled to occur in the near-term. Expansion of additional 3.5 mgd (product water) could occur in the mid-term, for an estimated capital cost of \$92 million for a total capital cost of \$130 million. | | | | |
| (2) An additional cost of \$400 million could be incurred in the future should 70 mgd of MBR treatment be installed at HWRP. | | | | |
| (3) Subtotal values have been rounded to the nearest million dollars. | | | | |

The overall CIP in 2017 dollars for HWRP is \$2,548 million, between 2018 and 2040, which equates to roughly \$110.7 million per year. The majority of the expenditures are anticipated to fall within the long-term phase. This is driven by the inclusion of the long-term concept option as well as the projected CIP values that were calculated. This same information is presented graphically on Figure 4.17.

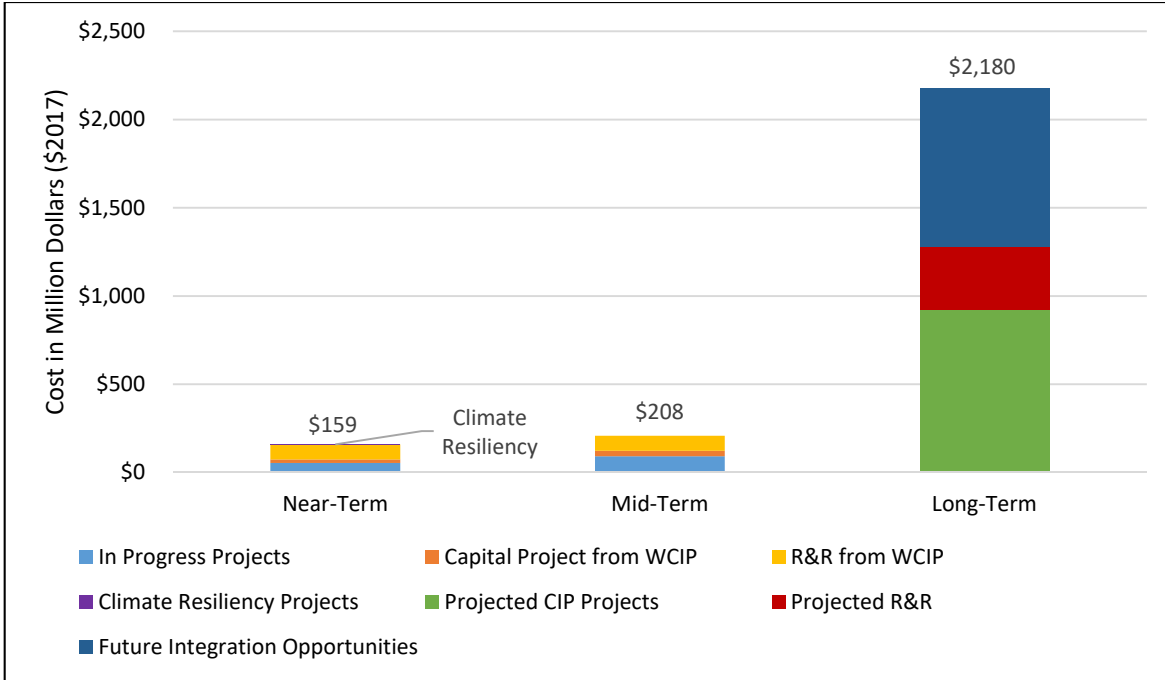

Figure 4.17 HWRP Adaptive CIP Summary by Phase

The HWRP Adaptive CIP costs summarized in Table 4.33 totals \$159 million in the near-term, \$208 million in the mid-term and \$2,180 million in the long-term. These totals translate to an average cost of approximately \$53 million per year from 2018 to 2020, \$20.8 million per year from 2021 to 2030, and \$218 million per year from 2031 to 2040.

Figure 4.18 presents the same information but depicts the total value by percent allocated to each category. The Estimated and Projected CIP is the largest of the three categories.

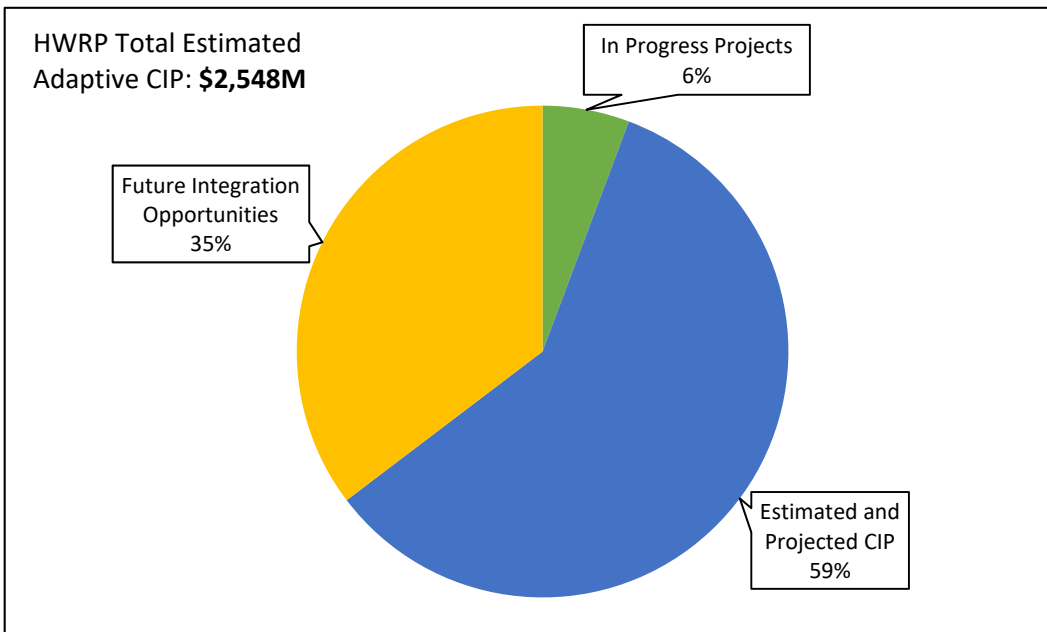

Figure 4.18 HWRP Adaptive CIP Summary by Category

The costs in the HWRP Adaptive CIP are presented in 2017 dollars but future costs should be adjusted to account for the time value of money. Section 4.5.5 discusses the escalation methodology used to account for these future values.

4.5.5 HWRP Adaptive CIP Net Present Worth Summary

The values for each of the projects were developed in 2017 dollars. Recognizing that the City will not implement all projects immediately, the projects have been divided into phases. The costs for the projects that are scheduled to be implemented in the near, mid, and long-term were adjusted to account for inflation and escalated at a rate of 3 percent per year. To allow a comparison of costs between phases, the escalated costs were then brought back to a present value using a discount rate of 2 percent per year. Discounting the escalated costs yields a net present value and reflects the future values in 2017 dollars.

The net present worth of the HWRP Adaptive CIP for all three phases totals approximately \$2,980 million. For the 2040 planning horizon, this total value equates to \$129.5 million on an annual basis. Figure 4.19 shows how the time value of money impacts each of the phases of the CIP.

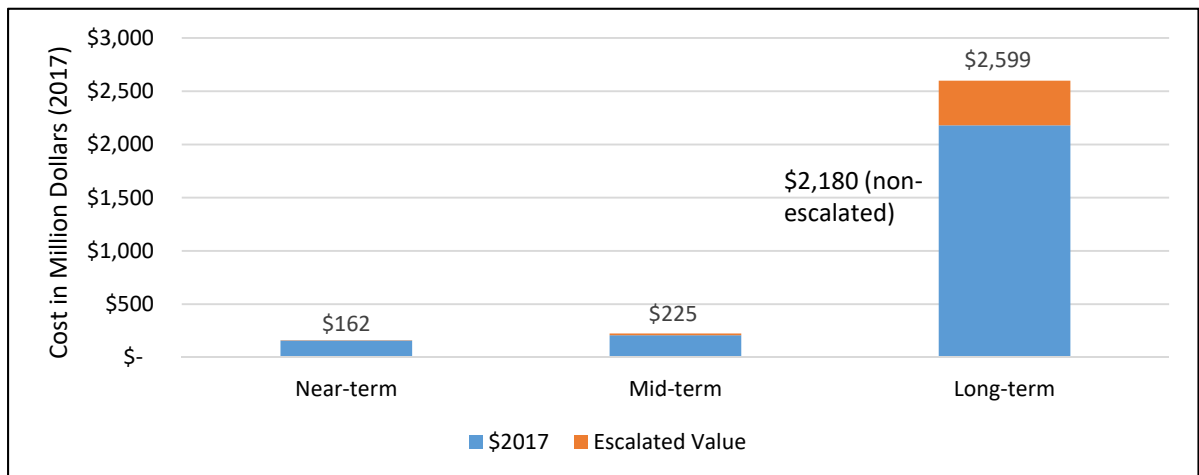

Figure 4.19 Present Worth Comparison: Escalated versus Non Escalated CIP

The long-term phase has the greatest impact on the CIP, due to the large amount of money that needs to be accounted for in today's dollars.

-This Page Left Blank Intentionally-

DONALD C. TILLMAN WATER RECLAMATION PLANT

Donald C. Tillman Water Reclamation Plant (DCTWRP) was constructed in 1985 and is the City's largest upstream reclamation plant. DCTWRP is a full tertiary treatment facility located in the San Fernando Valley. It is situated on a 91-acre site within the Sepulveda Control Basin in Van Nuys, south of Victory Boulevard, between Woodley Avenue and the San Diego Freeway (Interstate 405). The location and an overview of the plant is shown on Figure 5.1.

The initial plant was designed to treat an average dry weather flow of 40 mgd. This portion of the plant is known as Phase I. Phase II, completed in 1991, expanded the plant to treat an additional 40 mgd of Title 22 tertiary treated effluent for an overall plant design capacity of 80 mgd. The plant is rated for a PWWF of 160 mgd.

The plant receives its influent wastewater from the AVORS and the EVIS. The DCTWRP is an integral part of the City's wastewater system – in particular, the infrastructure associated with the Hyperion Service Area. The plant provides hydraulic relief for major interceptor sewers in the San Fernando Valley, as well as the North Outfall Sewer, the La Cienega-San Fernando Valley Relief Sewer tunnel through the Santa Monica Mountains, and downstream portions of the Hyperion system including HWRP. DCTWRP can increase or decrease the amount of flow diverted from the AVORS and EVIS into the plant as needed to maintain flows for operation.

DCTWRP serves numerous communities in the San Fernando Valley, including Canoga Park, Woodland Hills, Reseda, Panorama City, San Fernando, Sylmar, and Chatsworth. Agencies contracted with DCTWRP include Las Virgenes Municipal Water District, Triunfo County Sanitation District, and the City of San Fernando. The DCTWRP sewershed is shown on Figure 5.2.

5.1 EXISTING TREATMENT PROCESS DESCRIPTION

This section outlines existing systems at DCTWRP, documents plant upgrades, and is organized as follows:

- General plant overview
- Current flows and loadings
- Process descriptions
- Identified current needs

Understanding existing facilities is critical to the assessment of future potential projects to improve performance and enhance water reuse.

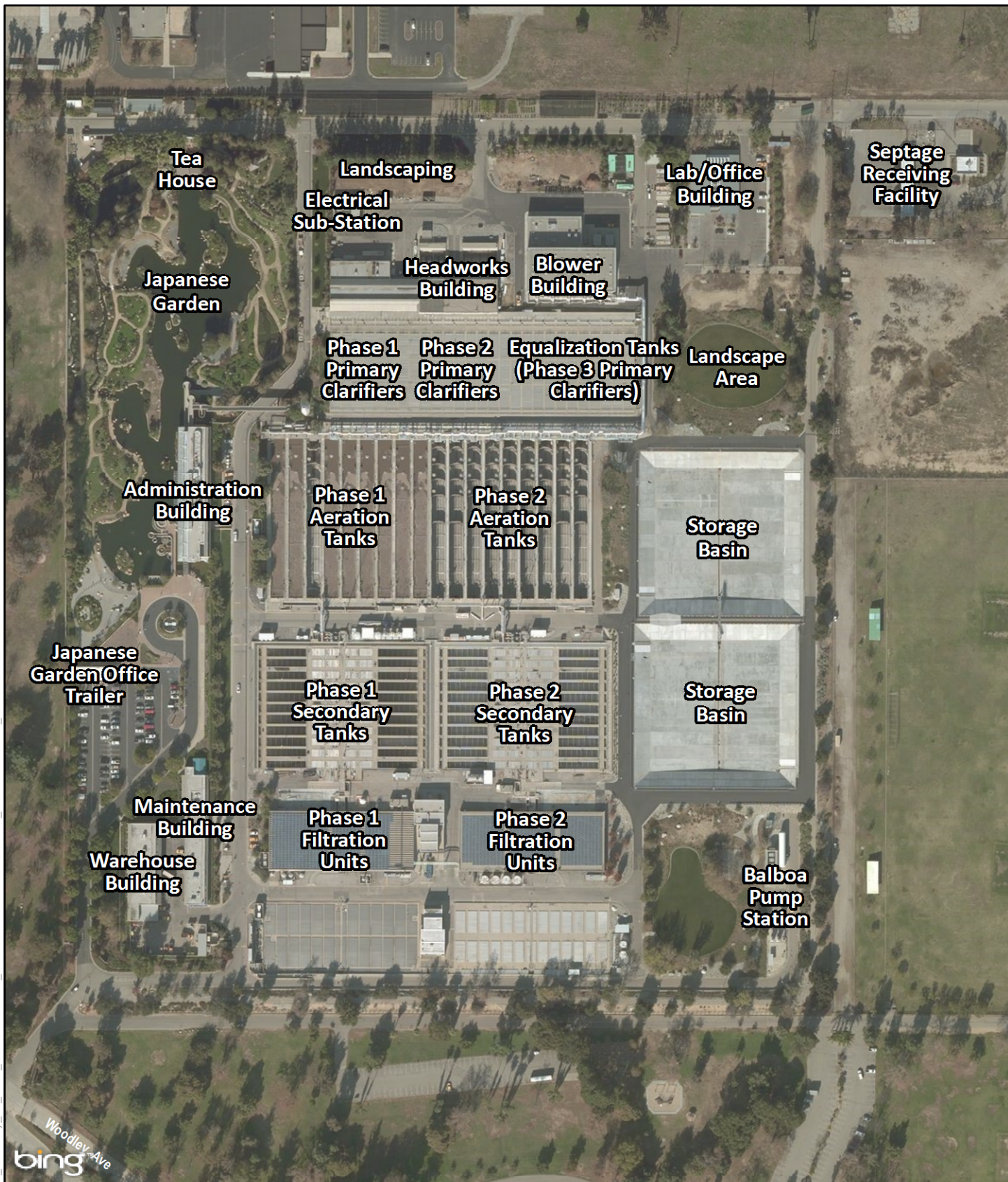
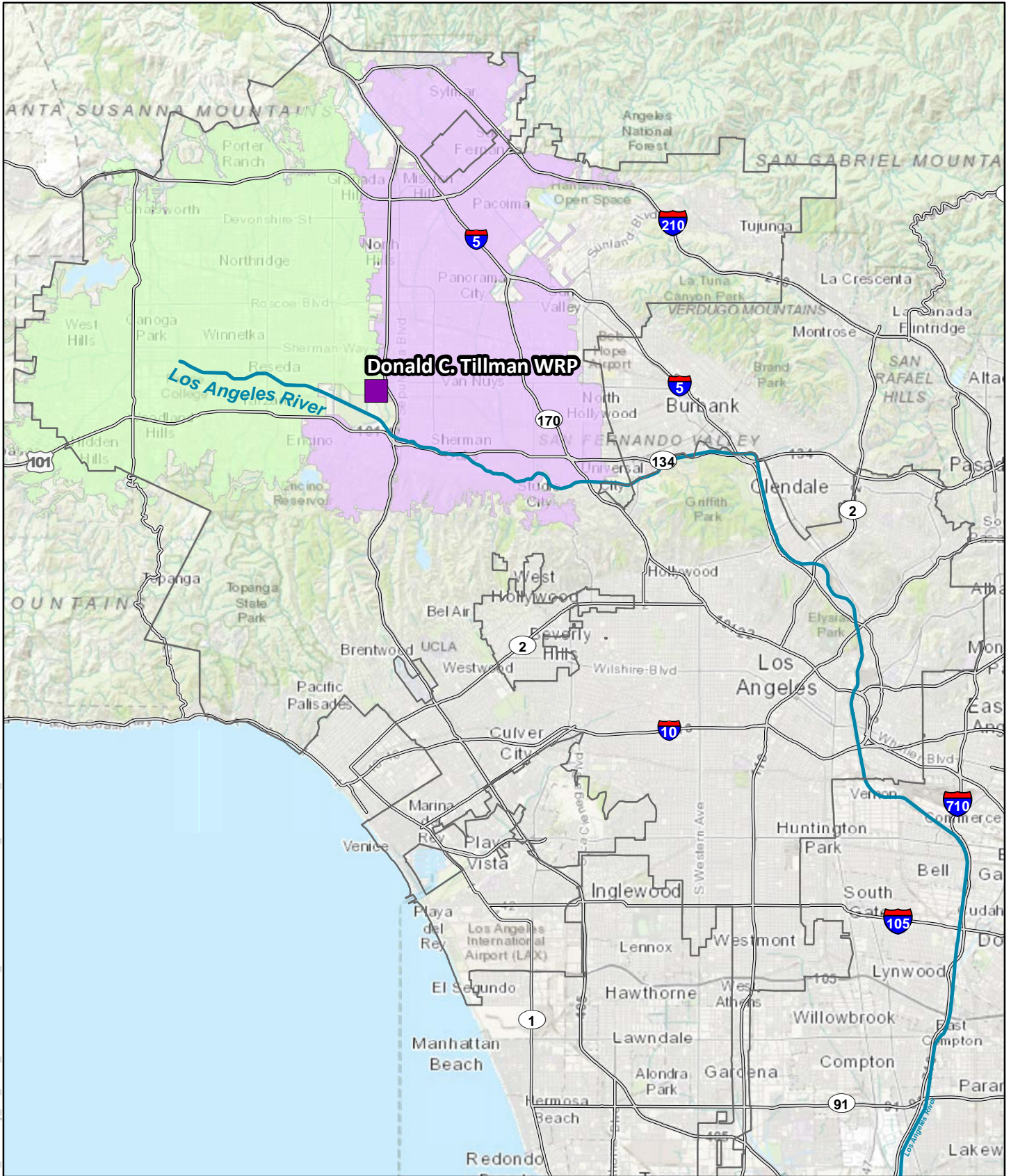

Figure 5.1
DCTWRP Aerial Overview
One Water LA 2040 Plan





- Existing Water Reclamation Plant (WRP)
- DCTWRP Sewershed
- Valley Springs Sewershed

Figure 5.2
DCTWRP Location and Sewershed
 One Water LA 2040 Plan

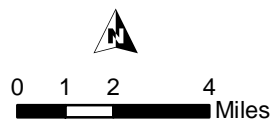

5.1.1 Treatment Process Overview

DCTWRP currently operates as a secondary treatment facility with full tertiary filtration capabilities. Its effluent is reclaimed and used for ornamental landscape lake makeup water or discharged to the LA River. The plant's process flow diagram is shown on Figure 5.3. Reading left to right, treatment include preliminary treatment (bar screens) and primary clarification followed by a multi-zone air activated sludge process operated to achieve secondary treatment as well as reduce nitrogen constituents. Tertiary filtration follows, along with disinfection prior to discharge/water reuse. Skimming and solids generated are returned to the sewer for treatment at HWRP.

The following sections provide an overview of influent and effluent flow characteristics as well as documenting the existing processes and operating conditions at DCTWRP for:

- Preliminary Treatment
- Primary Treatment
- Secondary Treatment
- Tertiary Treatment
- Disinfection

Ancillary facilities are also reviewed.

5.1.2 Influent Flow and Characteristics

The design parameters for the influent BOD and TSS concentrations are 280 mg/L and 300 mg/L, respectively, which correspond to loads of 187,000 pounds per day (lbs/day) of BOD and 200,000 lbs/day of TSS given the design flow rate of 80 mgd. Average influent characteristics for the fiscal year July 2014 to June 2015 are shown in Table 5.1.

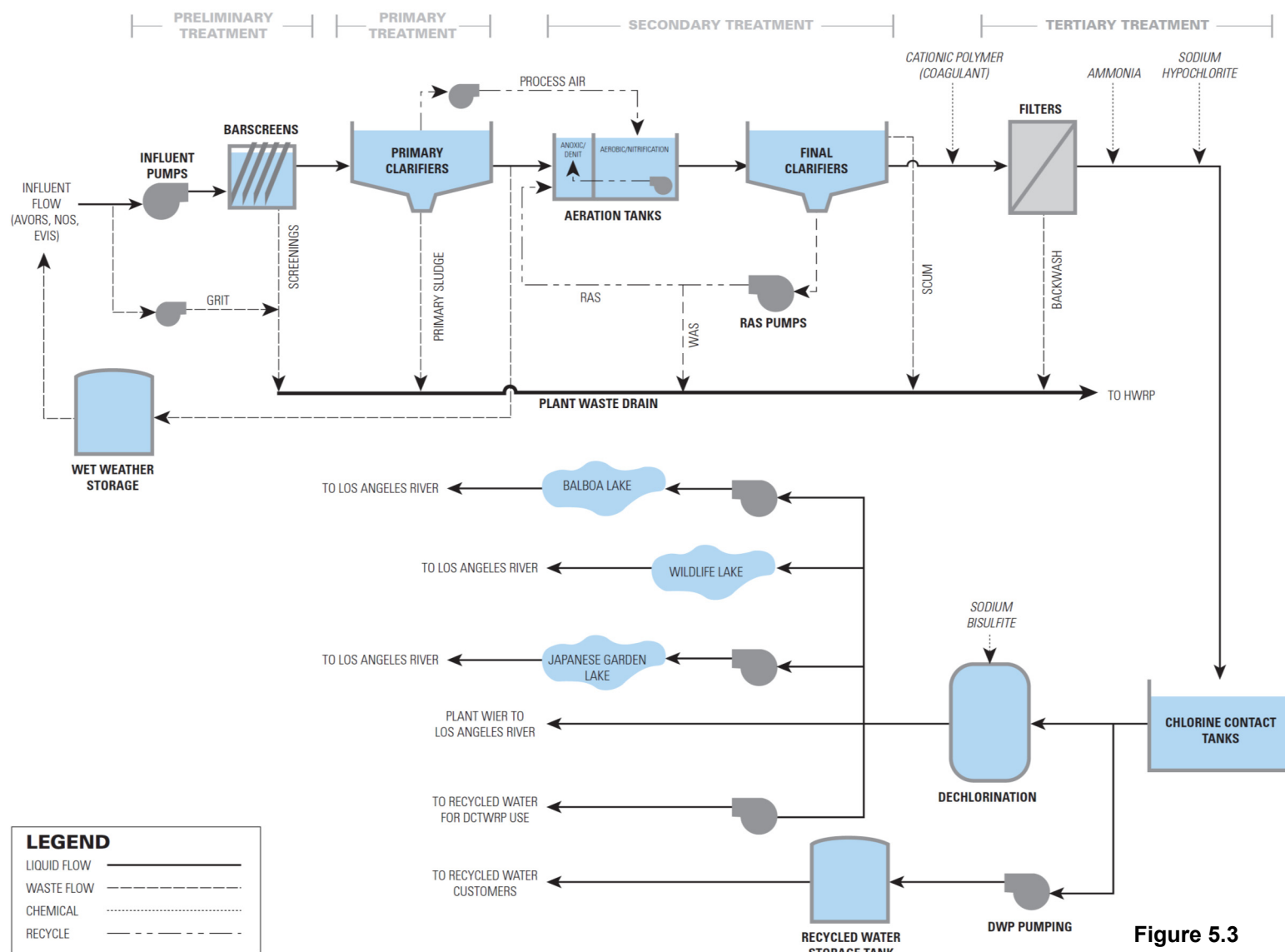

LEGEND

| | |
|-------------|-----------|
| LIQUID FLOW | ————— |
| WASTE FLOW | - - - - - |
| CHEMICAL | |
| RECYCLE | - · - · - |

Figure 5.3
DCTWRP Process Flow Diagram
 One Water LA 2040 Plan

| Table 5.1 DCTWRP Average Influent Flow and Quality Wastewater Facilities Plan One Water LA 2040 Plan | | |
|---------------------------------------------------------------------------------------------------------------------|---------------------|--------------|
| Description | Design Value | Value |
| Average Dry Weather Flow | 80 mgd | 44 mgd |
| Peak Dry Weather Flow | - | 54 mgd |
| Average BOD | | |
| Concentration | 280 mg/L | 299 mg/L |
| Mass Loading | 93 tpd | 55 tpd |
| Average TSS | | |
| Concentration | 300 mg/L | 289 mg/L |
| Mass Loading | 100 tpd | 53 tpd |
| Maximum Daily BOD | - | 476 mg/L |
| Maximum Daily TSS | - | 548 mg/L |
| <u>Note:</u> Based on Monthly Performance Reports July 2014 to June 2015. | | |

5.1.3 Effluent Flows and Characteristics

The plant effluent is compliant with Title 22 standards for disinfected tertiary recycled water and meets limits in DCTWRP's NPDES permit which are summarized in Table 5.2. Effluent is either reused or discharged to a variety of water bodies including the LA River.

5.1.4 Process Description

In the sections that follow, descriptions are provided of DCTWRP's liquid treatment processes and ancillary facilities. Provided are:

- Component descriptions and design criteria
- Summary of operations
- Current performance metrics

This information provides the foundational basis for the development of future plant improvements.

| Table 5.2 DCTWRP NPDES Effluent Limitations Wastewater Facilities Plan One Water LA 2040 Plan | | | | |
|--------------------------------------------------------------------------------------------------------------|----------------|----------------------------|---------------------------|--------------------------|
| Constituent | Units | Monthly Average | Weekly Average | Maximum Daily |
| BOD ₅ | mg/L | 20 | 30 | 45 |
| | lbs/day | 13,340 | 20,020 | 30,020 |
| TSS | mg/L | 15 | 40 | 45 |
| | lbs/day | 10,010 | 26,690 | 30,020 |
| pH | standard units | | 6.5 – 8.5 | |
| Oil and Grease | mg/L | 10 | -- | 15 |
| | lbs/day | 6,670 | -- | 10,010 |
| Settleable Solids | ml/L | 0.1 | -- | 0.3 |
| Total Residual Chlorine | mg/L | -- | -- | 0.1 |
| Total Dissolved Solids | mg/L | 950 | -- | -- |
| | lbs/day | 633,840 | -- | -- |
| Sulfate | mg/L | 300 | -- | -- |
| | lbs/day | 200,160 | -- | -- |
| Chloride | mg/L | 190 | -- | -- |
| | lbs/day | 126,770 | -- | -- |
| MBAS | mg/L | 0.5 | -- | -- |
| | lbs/day | 330 | -- | -- |
| Ammonia Nitrogen | mg/L | 3 | -- | 6.4 |
| Nitrate + Nitrite (as N) | mg/L | 7.2 | -- | -- |
| Nitrate (as N) | mg/L | 7.2 | -- | -- |
| Nitrite (as N) | mg/L | 0.9 | -- | -- |
| Temperature | | °F | | 86 |
| Turbidity | NTU | 2 | -- | -- |
| <i>Source: NPDES Permit No. CA0056227, Order No. R4-2017-0062</i> | | | | |
| <u>Abbreviation:</u> | | | | |
| MBAS = methylene blue-activated substances | | | | |

5.1.5 Preliminary Treatment

Preliminary treatment at DCTWRP consists of screening, grit removal, and influent pumping. Screening and grit removal maximize protection of subsequent plant processes by removing materials that can clog and damage equipment, thus causing excessive wear or reducing treatment efficiency. Pumping raises the hydraulic grade line of the influent to allow for gravity flow throughout the remainder of the plant.

The headworks building house equipment for Phase I and II and work to remove grit and coarse debris. This building contains influent pumps and an isolating sluice gate within the influent channel. Odor control is achieved through air containment, ducting, chemical addition (chlorine) and odor neutralizing compound misting.

The preliminary treatment process and various components are described below and summarized in Table 5.3.

| Table 5.3 DCTWRP Preliminary Treatment Design Criteria Wastewater Facilities Plan One Water LA 2040 Plan | |
|-------------------------------------------------------------------------------------------------------------------------|--------------------------------------------------------------|
| Unit | Value |
| Grit Pumps | |
| Type | Wemco |
| Number | 4 (2 duty, 2 standby) |
| Capacity, each | 600 mgd |
| Influent Pumps | |
| Type | Spaans Babcock, open screw |
| Number | 8 (7 duty, 1 standby) |
| Capacity, each | 32 mgd |
| Screens | |
| Type | Fairfield Mechanically Raked Climber, Continuous rake bar |
| Number | 7 (4 rake bar, 3 climber) |
| Capacity | 44 mgd (rake) 30 mgd (climber) |
| Flowmeters | |
| Type | Krohne, Magnetic |
| Number | 7 (6 duty, 1 standby) |
| Capacity, each | 60 mgd |
| <i>Sources: City of Los Angeles Integrated Resource Plan, 2006; Discussions with City Staff</i> | |

5.1.5.1 Grit Removal

Grit is removed from the influent flow by settling the grit at a reduced velocity into hoppers. The influent channel between the two headworks contains a sluice gate for isolation purposes. Each headworks utilizes one hopper, which contains two grit pumps.

5.1.5.2 Influent Pumping

Influent flows are pumped to increase their head by 30 feet using 8-foot diameter screw pumps. Following this initial pumping, flows then continues through the plant by gravity. There are eight screw pumps in total, each with a capacity of approximately 32 mgd. An isolating sluice gate precedes each screw pump and its accompanying wet well. Phase I and Phase II contain four screw pumps each. These screw pumps are driven by 300 hp motors.

5.1.5.3 Screening

There are three climber-type bar screens in Phase I, each having a design capacity of 44 mgd. Phase II contains four continuous rake bar screens, each with a design capacity of 30 mgd. Isolating inlet slide gates and outlet knife gates are located at each end of their respective channels.

5.1.5.4 Metering

There are three magnetic flowmeters in Phase I and four magnetic flowmeters in Phase II. They each have a capacity of 60 mgd.

5.1.5.5 Operation

Each grit hopper contains two grit pumps; however, only one pump is typically in service. Standard operations consist of one duty pump and one standby pump. Each grit pump is constant speed and has a capacity of 600 gpm. The grit is then pumped through an in-plant sewer to AVORS and sent to HWRP for final treatment and disposal.

The screw pumps normally operate in a prioritized sequence, and are started or stopped in response to levels in the influent channel. Two to three screw pumps are required for normal operation. During dry weather, a single pump can be used. For planning, it will be assumed that one pump is out of service, leaving seven duty pumps.

The continuous bar screens and raked climbers move solids collected into a sluiceway cleansed by a continuous supply of high-pressure effluent (HPE). This waste is conveyed through in-plant sewers to AVORS and eventually to HWRP for final treatment.

After screening flow passes through magnetic flowmeters. The magnetic flowmeters are located in-line, between the screen and the outlet knife gate of each bar screen channel.

5.1.5.6 Current Performance

The preliminary treatment systems are currently operating with no significant issues.

5.1.6 Primary Treatment

Primary treatment allows time for settleable organic and inorganic materials that enter the plant to settle and be removed. Lighter solids (i.e. floatables, grease, etc.) float to the

surface and are removed by skimming. The remaining wastewater is conveyed to the aeration tanks for secondary treatment. Primary treatment significantly reduces the BOD and TSS loadings to the secondary treatment facilities. The primary treatment process at DCTWRP includes:

- Primary Clarifiers
- Flow Equalization

Flow equalization tanks were built during the Phase II expansion of DCTWRP. Their design is similar to that of primary clarifiers, but without the internal mechanisms. These flow equalization tanks were constructed to aid in stabilizing the wide diurnal variation of wastewater flows, as fluctuating flow rates and loadings can have an adverse impact on the secondary treatment process.

DCTWRP has 18 rectangular primary clarifiers, nine in each phase, with dimensions of 200 feet by 20 feet and a side-water depth of 12 feet. The flow into each of these in-service tanks is controlled manually by knife gate valves depending on current treatment needs. The primary clarifiers are covered, the air below being withdrawn and used as the process air in the secondary treatment systems.

Phase I utilizes conventional steel chain and sprockets and uses redwood flights for solids collection. Phase II uses plastic chain and sprockets, with fiberglass flights. Table 5.4 details the design criteria for the primary clarifiers.

| Table 5.4 DCTWRP Primary Clarifiers Design Criteria Wastewater Facilities Plan One Water LA 2040 Plan | |
|----------------------------------------------------------------------------------------------------------------------|--------------------------|
| Unit | Value |
| Primary Clarifiers | |
| Number | 18 (11 duty, 7 off-line) |
| Number per Phase | 9 |
| Area | 200 ft x 20 ft |
| Water Depth | 12 ft |
| Surface Overflow Rate | 1,150 gpd/sq ft |
| Detention Period @ ADF | 1.9 hours |
| Capacity, each | 4.6 mgd |
| <i>Source: City of Los Angeles Integrated Resource Plan, 2006; Discussions with City Staff</i> | |
| <u>Abbreviation:</u> ADF = average day flow | |

There are a total of nine rectangular equalization tanks, measuring 200 feet by 20 feet, with an average 12-foot side water depth. Each equalization tank has a storage capacity of 0.36 MG. Sizing characteristics of primary equalization facilities are shown in Table 5.5.

| Table 5.5 DCTWRP Primary Flow Equalization Facilities Wastewater Facilities Plan One Water LA 2040 Plan | |
|------------------------------------------------------------------------------------------------------------------------|----------------|
| Unit | Value |
| Equalization Tanks | |
| Number | 9 |
| Area | 200 ft x 20 ft |
| Water Depth | 12 ft |
| Volume, each | 0.36 MG |
| <i>Source: City of Los Angeles Integrated Resource Plan, 2006; Discussions with City Staff</i> | |

5.1.6.1 Operation

Floating material or scum is conveyed to the effluent end of each tank and then lifted by a helical skimmer into a sluiceway. The scum is washed using primary effluent and conveyed to in-plant sewers and back to AVORS. The primary sludge is moved to the two hoppers at the inlet end of the tank. Primary sludge withdrawal is automated; each sludge hopper per primary clarifier is sequentially opened and remains opened until a preset sludge density is achieved. Sludge withdrawal is continued by gravity and is conveyed into the in-plant sewers, and returned to the AVORS. Primary effluent exits the primary clarifier and enters its designated distribution channel, Channel 2.

In peak morning hours, primary effluent flow above the ADWF is diverted to the equalization tanks for storage. Stored primary effluent is then reintroduced to the headworks through the sludge hopper valves at the bottom of the tank and the equalization return line. Since the basins are downstream of the influent pump station, there is sufficient hydraulic head to return the stored primary effluent back to the headworks, upstream of the pump station. This return occurs during low flow hours, thus maintaining a relatively constant flow to the secondary treatment process.

5.1.6.2 Current Performance

Using the design average flow of 44 mgd, the detention time is 1.9 hours and the surface overflow rate is approximately 1,100 gpd/sq ft. For the fiscal year July 2014 to June 2015, the primary effluent TSS and BOD concentrations were 67 mg/L and 164 mg/L, respectively. Table 5.6 summarizes typical operational values and removal efficiencies in the period from July 2014 to June 2015.

| Table 5.6 DCTWRP Primary Treatment Performance Wastewater Facilities Plan One Water LA 2040 Plan | |
|-----------------------------------------------------------------------------------------------------------------|--------------------------|
| Description | Values |
| Average Primary Influent Flow | 44 mgd |
| Average Sludge Flow | 1.3 mgd |
| Average Surface Overflow Rate (SOR) | 1,018 to 1,254 gpd/sq ft |
| Primary Effluent TSS | 67 mg/L |
| Primary Effluent BOD | 164 mg/L |
| Primary Effluent Settleable Solids | 0.24 mg/L |
| Average BOD Removal Efficiency | 44% |
| Average TSS Removal Efficiency | 76% |
| Average Settleable Solids Removal Efficiency | 98.46% |
| <i>Source: Monthly Performance Reports July 2014 to June 2015.</i> | |

As shown in Table 5.6, the primary treatment process is performing as expected and is at capacity with one phase on-line. Increased use of flow equalization will be utilized to attenuate the occurrence of peak ammonia concentrations and loadings. Also, in order for DCTWRP to eventually produce a constant flow of 80 mgd, the volume of the primary flow equalization facilities needs to be increased.

5.1.7 Secondary Treatment

The purpose of secondary treatment is to remove soluble BOD that is not removed by primary treatment and provide further removal of suspended solids. The secondary treatment process at DCTWRP includes:

- Nitrification/Denitrification Aeration Tanks
- Process Air System
- Secondary Clarifiers
- Return Activated Sludge Pump System
- Waste Activated Sludge System

The design basis, operations, and current performance of each of these are provided in the subsections that follow.

5.1.7.1 Nitrification/Denitrification Aeration Tanks

DCTWRP utilizes the secondary treatment process of biological nitrogen removal, which has two steps, nitrification and denitrification (NdN). In nitrification, organic nitrogen (organic-N) compounds and NH₃-N are converted to nitrite (NO₂-N) and then to nitrate

(NO₃-N). This process requires aerobic conditions. In denitrification, nitrate is converted to nitrogen gas that is eventually discharged to the atmosphere. This process requires that the process stream lacks dissolved oxygen, so the nitrate is the main source of oxygen. The denitrification process requires a carbon source.

DCTWRP conducted a full-scale pilot plant from 1998 to 2002 to determine the best method of incorporating NdN into its existing processes. As a result of this testing, DCTWRP chose to reconfigure the existing aeration tanks into anoxic and aerated zones utilizing the Modified Ludzack Ettinger (MLE) process. In 2006, DCTWRP modified its existing aeration tanks into anoxic and aerobic zones. Table 5.7 details the specific zones and their respective dimensions.

| Table 5.7 DCTWRP NdN Zone Description Wastewater Facilities Plan One Water LA 2040 Plan | | | |
|--------------------------------------------------------------------------------------------------------|--------------------|------------------------|----------------------------|
| Zone | Description | Length (ft) | Size (% volume) |
| Zone #1 | Mixing | 15 | 5 |
| Zone #2 | Anoxic | 30 | 10 |
| Zone #3 | Anoxic | 30 | 10 |
| Zone #4 | Anoxic | 30 | 10 |
| Zone #5 | Aerobic | 195 | 65 |

Source: City of Los Angeles Integrated Resource Plan, 2006; Discussions with City Staff

Compressed air is distributed through fine bubble air diffusers. Additionally, each tank contains three unique diffusion grids that allow air rates to be customized as needed. A blow-off valve accompanies each grid to reduce moisture that accumulates during operation. Phase I utilizes ceramic discs, while Phase II uses ceramic domes.

There are a total of 18 rectangular aeration tanks, nine in each phase. Each tank measures 300 feet by 32 feet, with a 16-foot average water depth. Table 5.8 summarizes the process design criteria for the aeration tanks per phase along with descriptions of the mixers and pumps.

| Table 5.8 DCTWRP NdN Aeration Tanks per Phase Design Criteria Wastewater Facilities Plan One Water LA 2040 Plan | |
|--------------------------------------------------------------------------------------------------------------------------------|------------------------|
| Unit | Value |
| Aeration Tanks | |
| Number per Phase | 9 (8 duty, 1 off-line) |
| Surface Area, each | 300 ft x 32 ft |
| Water Depth | 16 ft |
| Internal Recycle Ratio | 4:1 |
| RAS Ratio | 1:0.8-1.5 |
| Average Anoxic Detention Time ⁽¹⁾ | 1.06 hr |
| Average Aeration Detention Time ⁽¹⁾ | 2.26 hr |
| Mixers | |
| Type | US Filter |
| Number | 45 (5 per basin) |
| Power, each | 6.5 hp |
| Internal Recycle Pump | |
| Type | Sulzer |
| Number | 18 |
| Capacity, each | 21,000 gpm |
| Head, each | 1.9 ft |
| Power, each | 30 hp |
| <i>Source: City of Los Angeles Integrated Resource Plan, 2006; Discussions with City Staff</i> | |
| <u>Note:</u> | |
| (1) Average Detention times for July 2014 through June 2015 | |
| <u>Abbreviation:</u> | |
| ADF = average day flow | |

5.1.7.2 Operation

The first zone is for anoxic mixing of the RAS with primary effluent for denitrification. Mixed liquor recycle flows provide nitrates from the nitrification zone and the primary effluent provides the required carbon source.

The second zone is configured to act as anaerobic or anoxic, otherwise known as a "swing" zone. Though it was initially being used as a selector zone to help control filamentous bacteria, it is currently operated with the swing zone air off and is thus acting as anoxic.

The third and fourth zones are anoxic zones to continue the denitrification process. The internal recycle (mixed liquor) pump is able to transport the nitrates formed in the nitrification zone to the anoxic zones. The nitrate-rich mixed liquor internal recycle ratio is 4:1.

The fifth zone is the aeration zone needed for nitrification. The ammonia from the primary effluent passes through all other zones unchanged, and is converted to nitrate in this zone. The RAS and internal recycle transports this nitrate wastewater to the anoxic zones for denitrification.

5.1.7.3 Current Performance

The peak concentration of ammonia has increased, which results in a bleed through of ammonia and nitrate. While daily average concentrations have not showed any changes, peak concentrations have increased from 40 mg/L to 60 mg/L during the period of July 2014 to June 2015. Operations is planning to utilize five equalization tanks and alter the filling and releasing to see how equalization may reduce peak ammonia concentrations. This current performance of the NdN facility will impact the appropriate disinfection control strategy.

Table 5.9 presents current performance data for the NdN system.

| Table 5.9 DCTWRP Secondary Treatment Performance Wastewater Facilities Plan One Water LA 2040 Plan | |
|--------------------------------------------------------------------------------------------------------------------------|-----------------------|
| Description | Value |
| Average Influent Flow | 35 mgd ⁽¹⁾ |
| Average RAS Flow | 29.1 mgd |
| Average Internal Recycle Flow | 115.6 mgd |
| Average WAS Flow | 0.6 mgd |
| Average Scum Flow | 1.7 mgd |
| Average Total Detention Time | 3.52 hr |
| Average RAS Ratio | 83% |
| Average Recycle Ratio | 332% |
| Average BOD Removal Efficiency | 94% |
| Average TSS Removal Efficiency | 91% |
| Average NH ₃ -N Removal Efficiency | 98% |
| Average Secondary Effluent BOD | 9.7 mg/L |
| Average Secondary Effluent TSS | 5.79 mg/L |
| Average Secondary Effluent NH ₃ -N | 0.51 mg/L |
| <i>Source: Monthly Performance Reports July 2014 to June 2015</i> | |
| <u>Note:</u> | |
| (1) Flow into the secondary treatment process is less than the influent to the plant due to the flows that are bypassed. | |

5.1.7.4 Process Air System

The process air system supplies air required to the aeration tanks through Siemens blowers. Blowers at DCTWRP use foul air collected from the primary sedimentation tanks, channels 1 and 2, and headworks as the source. Because foul air from these sources typically has hydrogen sulfide and other odorous volatile organic compounds (VOC) as a byproduct, utilizing this source for aeration is permitted by the SCAQMD as "DCTWRP odor/emission control process". Aeration tanks with fine bubble aeration diffusers provide odor removal by absorption, condensation, and microbial oxidation resulting in lower VOC's emissions for DCTWRP. This system is considered effective in treating moderate to high strength odors. Systems have been in operation for 40 years, and more than 25 facilities have used this technology including 3 City Plants (DCTWRP, LAGWRP and TIWRP).

An odor improvement project currently in the bid and award phase will add an additional step in the series, a bio-filter between the source and aeration tanks to provide further reduction of VOC's and particulates in the future.

Process air and channel air are currently supplied by five 3,000 hp centrifugal blowers, each having a capacity of 55,000 scfm. The blowers are located in the Compressor Building. The system is provided with the ability to blend fresh air into the foul air prior to entering the blowers through the use of external louvers. A 60-inch diameter pipe east of the equalization tanks travels westward above Channel 2 and decreases in diameter until it reaches Aeration Tank 1. Each lateral has an electrically operated header valve and can supply up to two aeration tanks. An electrically operated valve on each lateral controls the airflow to the aeration grid. The main airline also branches outward to supply each of the distribution channels (i.e., Channels 1, 2, 3, and 4) with air. Table 5.10 summarizes the process air system design criteria for DCTWRP.

| Table 5.10 DCTWRP Process Air System Design Criteria Wastewater Facilities Plan One Water LA 2040 Plan | |
|-----------------------------------------------------------------------------------------------------------------------|-----------------------|
| Unit | Value |
| Blowers | |
| Type | Centrifugal |
| Number | 5 (4 duty, 1 standby) |
| Capacity, each | 55,000 scfm |
| <i>Source: City of Los Angeles Integrated Resource Plan, 2006; Discussions with City Staff</i> | |

5.1.7.5 Operation

The air supply is a combination of ambient air and foul air removed from the headworks buildings, Channel 1 and 2, and the covered primary clarifiers. This process serves as the primary form of odor control at DCTWRP. The air travels through the activated sludge

process and absorbs, adsorbs, oxidizes, or biologically converts the odorous compounds to non-odorous compounds.

5.1.7.6 Current Performance

Foul air currently deposits particulates and hydrogen sulfide on the blowers, causing the blowers to seize up. This prevents the supply of air from reaching the aeration tanks. The foul air causes equipment failure, thus reducing reliability. Capital improvement project #6171, Blower Air Clean-Up System is expected to improve operations.

5.1.7.7 Secondary Clarifiers

Treated wastewater flows into the secondary clarifiers where microorganisms settle out. The majority of the settled microorganisms are then recycled to the aeration tanks to treat incoming primary effluent (RAS). Excess organisms (WAS) are discharged (wasted) to the sewer system for final treatment at HWRP.

DCTWRP has a total of 44 secondary clarifiers, 22 in each phase. Each tank has three inlet valves, two effluent V-notch weirs, and two sludge hoppers. Floating material is conveyed to the influent end of the tank, where a slotted pipe skims the surface for removal. The settled sludge is then moved to the two hoppers at the effluent end of the tank. Table 5.11 provides a design criteria summary of the secondary clarifiers.

| Table 5.11 DCTWRP Secondary Clarifiers Design Criteria Wastewater Facilities Plan One Water LA 2040 Plan | |
|-------------------------------------------------------------------------------------------------------------------------|-----------------------|
| Unit | Value |
| Secondary Clarifiers | |
| Number | 44 (22 in each phase) |
| Area | 150 ft x 20 ft |
| Side Water Depth (SWD) | 12 ft |
| Surface Area per Clarifier | 3,000 sq ft |
| Surface Overflow Rate (SOR) | 605 gpd/sq ft |
| <i>Source: City of Los Angeles Integrated Resource Plan, 2006; Discussions with City Staff</i> | |

5.1.7.8 Operation

The tanks are arranged in treatment trains, with 11 tanks on each side of each Phase. Effluent enters the aeration tanks and travels around the perimeter of the tanks in Channels 4A through 4D. Effluent from the secondary clarifiers discharges to a common channel, Channel 5, located at the center of each train. Sludge from the tank enters a wet well and is subsequently pumped back to the inlet end of its respective aeration tank as RAS, or is wasted to AVORS as WAS.

5.1.7.9 Current Performance

In current operations, the average surface overflow rate is 578 gpd/sq ft with an average detention time of 2.0 hours. Table 5.12 summarizes operational conditions for the secondary clarifiers.

| Table 5.12 DCTWRP Secondary Clarifiers Performance Wastewater Facilities Plan One Water LA 2040 Plan | |
|---------------------------------------------------------------------------------------------------------------------|------------------|
| Description | Value |
| Average Flow | 35 mgd |
| Number of Units in Service | 20 |
| Average Surface Overflow Rate (SOR) | 578 gpd/sq ft |
| Average Surface Loading Rate | 30.8 lbs/d/sq ft |
| <i>Source: Monthly Performance Reports July 2014 to June 2015</i> | |

Table 5.12 shows that the secondary clarifiers are operated close to the original design basis. There are no current operational issues with the secondary clarifiers at DCTWRP.

5.1.7.10 RAS System

The RAS is returned to its respective wet well by gravity. It is then pumped by vertical turbine-type pumps, each having a capacity of 10,000 gpm at 35 feet TDH. The pumps are designed to operate in parallel to allow a variable flow into the aeration tanks. A summary of the RAS system of DCTWRP's secondary treatment process is presented in Table 5.13.

| Table 5.13 DCTWRP RAS System Design Criteria Wastewater Facilities Plan One Water LA 2040 Plan | |
|---------------------------------------------------------------------------------------------------------------|------------------------|
| Unit | Value |
| RAS Pumps | |
| Type | Variable-speed, Sulzer |
| Number | 3 (1 duty, 2 standby) |
| Capacity, each | 10,000 gpm |
| Head, each | 35 ft |
| Power, each | 150 hp |

5.1.7.11 Operation

Cascade control is used for RAS distribution. The RAS flow required to each aeration tank is calculated based on the following parameters: 1) measured influent flow to the aeration tanks, and 2) operator-entered RAS/influent flow ratio, which is dependent on the BOD of the primary effluent.

While each phase has a dedicated RAS line, there is a crossover valve that can be opened to send RAS to either phase. This valve typically remains closed. A magnetic flowmeter, a programmable flow controller, and a motorized butterfly valve regulate the flow to each aeration tank.

Mannich polymer is added to the RAS line to control foaming in the aeration basins.

5.1.7.12 Current Performance

At this time, there are no operational or performance issues for the RAS system at DCTWRP.

5.1.8 Tertiary Treatment

Recycled water use is governed by the Water Reclamation Criteria, which are detailed within Title 22 of the California Code of Regulations. DCTWRP currently treats flow to Title 22 tertiary treatment requirements. This level of treatment, or "tertiary treatment," consists of coagulant addition and rapid sand/dual media or cloth filtration. Filtration is used in tertiary treatment to remove residual suspended solids remaining after secondary treatment and is aided by coagulation.

Coagulation is the addition of chemicals to destabilize colloidal suspensions to allow for the formation of a settleable floc. At DCTWRP, this is facilitated by polymer. A Water Champ in-line mixer has been installed in each phase, upstream of the filters in Channel 5.

In 2009, DCTWRP completely retrofitted the filters with Aqua Diamond cloth media filters. The Aqua Diamond fit the same footprint as the previous filters and provided twice the treatment capacity. Eight filters (four per phase) were installed. Filtration rates are 2.3 gallons per minute per square foot (gpm/sq ft) at average flows. Table 5.14 shows the existing tertiary treatment facility characteristics.

| Table 5.14 DCTWRP Tertiary Treatment Facilities Design Criteria Wastewater Facilities Plan One Water LA 2040 Plan | |
|----------------------------------------------------------------------------------------------------------------------------------|-----------------------|
| Unit | Planning Value |
| Chemical Addition | |
| Polymer (Cationic) | Intermittent Use |
| Aqua Diamond Filters | |
| Number | 8 (4 duty, 4 offline) |
| Type | Cloth Media |
| Average Flow, each | 12.5 mgd |
| Maximum Flow, each | 24 mgd |

| Table 5.14 DCTWRP Tertiary Treatment Facilities Design Criteria Wastewater Facilities Plan One Water LA 2040 Plan | |
|----------------------------------------------------------------------------------------------------------------------------------|-----------------------|
| Unit | Planning Value |
| Filtration rate (Maximum) | 2.3 gpm/sq ft |
| Aqua Diamond Backwash Pumps | |
| Number | 8 |
| Capacity, each | 550 gpm |
| Head, each | 75 ft |
| Power, each | 20 hp |
| <i>Source: From Integrated Plan for Wastewater Program documents and discussions with City staff.</i> | |

5.1.8.1 Operation

Under normal operations, cationic polymer is continuously gravity fed. The Aqua Diamond cloth media is completely submerged during filtration. As the secondary effluent flows through the media, solids are deposited on the outside of the cloth. The filtered effluent then is collected inside the diamond lateral and continues to flow by gravity to discharge. Increased headloss due to deposited solids automatically initiates periodic backwashing.

5.1.8.2 Current Performance

There are no current performance issues with the coagulation process at DCTWRP but the plant may consider the use of other coagulants in the future.

The cloth on the Phase I filters have recently been changed and the cloth on the Phase 2 filters will be changed in the near-term. There are currently no performance issues with the filtration process. The filtration process currently operates with an average flow rate of 2.3 gpm/sq ft, an average effluent turbidity of 0.98 NTU and an average removal efficiency of 60 percent. The filters have an average backwash of 0.23 mgd.

5.1.9 Disinfection

Disinfection is necessary to meet the water reuse requirements dictated by Title 22 of the California Code of Regulations. DCTWRP at one time used chlorine gas (Cl₂) as a disinfectant. However, due to potential hazards, chlorine gas was replaced with liquid sodium hypochlorite solution (NaOCl) at the end of 1999.

Sodium hypochlorite is stored in four, 20,000-gallon capacity fiberglass-reinforced plastic (FRP) storage tanks, located south of the Phase II filters. Ten metering pumps provide 12.5 percent sodium hypochlorite solution to various application points. Four of the metering pumps have been changed within the last six years, and the remaining equipment was installed in 1984. Table 5.15 shows the existing disinfection facilities characteristics.

| Table 5.15 DCTWRP Disinfection Facilities Design Criteria Wastewater Facilities Plan One Water LA 2040 Plan | |
|----------------------------------------------------------------------------------------------------------------------------|-----------------------|
| Unit | Planning Value |
| Chlorine Contact Basins | |
| Number | 4 (2 per phase) |
| Channels, each | 13 |
| Area | 120 ft x 10 ft |
| Water Depth | 16 ft |
| Detention Period at 80 mgd | 2 hours |
| Chlorine Dose | 9 -14 mg/L |
| Chemical Storage Tanks | |
| Chemical | Sodium hypochlorite |
| Concentration | 12.5% |
| Number of tanks | 4 |
| Capacity, each | 20,000 gallons |
| Metering Pumps | |
| Type | Prominent/Periflow |
| Number | 10 |
| Capacity at 44 psi, each | 476 gpd |
| <i>Source: From Integrated Plan for Wastewater Program documents and discussions with City staff.</i> | |

5.1.9.1 Operation

The main application point for disinfection is located in the filter effluent channel, before the flow splits to the chlorine contact tanks. Filter effluent passes one of two operation induction units, where sodium hypochlorite is injected throughout the water column as it enters a 72-inch pipe. This pipe then leads to the contact tank inlet box. A combination of oxidation-reduction potential (ORP) meters and chlorine residual analyzers are used to automatically control the dosing process. There are a total of four chlorine contact tanks, two in each phase, which provide a detention time of two hours at the design capacity of 80 mgd.

Chlorine solution is also occasionally distributed to other application points. These application points include the Phase 1 influent channel for odor control, the filters for shock chlorination to prevent biological growth buildup in filter media, and the RAS pump discharge header for filament control.

Ammonia hydroxide (NH_4OH) is added before disinfection to reduce the formation of THMs as a disinfection byproduct. The ammonia will react with the chlorine disinfectant to produce chloramines, which are an effective disinfectant that produce less THMs than free chlorine addition.

5.1.9.2 Current Performance

The current performance of the NdN facilities results in an occasional bleed-through of ammonia. This additional ammonia then affects the amount of ammonia that is needed to be added in the disinfection stage.

The plant maintains the permitted requirement of 0.1 mg/L of residual chlorine in the final effluent, but are looking into other means for disinfection. Studies are underway to examine the replacement of chlorine in the disinfection process to reduce NDMA formation (N-Nitrosodimethylamine (NDMA) Precursor Control Strategies for DPR Project Study) and subsequent discharge to receiving waters. Operational information for the disinfection facilities is presented in Table 5.16.

| Table 5.16 DCTWRP Disinfection Performance Wastewater Facilities Plan One Water LA 2040 Plan | |
|-------------------------------------------------------------------------------------------------------------|--------------|
| Description | Value |
| Average Chlorine Contact Tank Influent Flow | 32.5 mgd |
| Average Sodium Hypochlorite Usage | 3,219 gpd |
| Average Concentration x Contact Time (CT) | 663 min-mg/L |
| Average Detention Time | 2.8 hr |
| <i>Source: Monthly Performance Reports July 2014 to June 2015</i> | |

This information will be used in subsequent studies to analyze the use of other disinfectants to replace chlorine.

5.1.10 Dechlorination

DCTWRP previously used sulfur dioxide gas (SO_2) in the dechlorination process, but changed to sodium bisulfite (NaHSO_3) in 2000 to reduce potential hazards.

Sodium bisulfite is stored in two, 15,000 gallon FRP storage tanks, located adjacent to the east end of the Phase II contact tanks. Dechlorination facility characteristics are described in Table 5.17.

| Table 5.17 DCTWRP Dechlorination Facilities Design Criteria Wastewater Facilities Plan One Water LA 2040 Plan | |
|------------------------------------------------------------------------------------------------------------------------------|-----------------------|
| Unit | Planning Value |
| Chemical Storage Tanks | |
| Chemical | Sodium bisulfite |
| Number | 2 |
| Capacity, each | 15,000 gal |
| Chemical Metering Pumps | |
| Type | Prominent/Periflow |
| Number | 3 |
| Capacity, each at 44 psi | 476 gpd |
| Spike Suppression Station Storage Tanks | |
| Number | 2 |
| Capacity, each | 3,600 gal |
| Metering Pumps | |
| Number | 2 |
| Capacity, each | 220 gpd |
| <i>Source: From Integrated Plan for Wastewater Program documents and discussions with City staff.</i> | |

5.1.10.1 Operation

The dechlorination system operates similar to the chlorination system. The contact tank effluent from the chlorine contact tank is tested for chlorine residual, which then determines the operation of the chemical metering pumps and dechlorinating Water Champs. If chlorine residual is detected, a spike suppression system is activated. This system releases additional sodium bisulfite to diffusers located downstream of the dechlorinating Water Champ installation.

5.1.10.2 Current Performance

DCTWRP currently uses, on average, 1,436 gpd of sodium bisulfite in its dechlorination system. The Spike Suppression Station Storage Tanks pumps were freezing, so heat was added to prevent this issue. Additional operational considerations include issues with chlorine spikes. To help with this performance issue, the chlorine system will be rehabilitated to a diffuser system.

5.1.11 Effluent Water Reuse

DCTWRP produces Title 22 tertiary effluent for multiple water reuse systems, including DCTWRP's HPE system, DCTWRP's low pressure effluent (LPE) system, and non-potable

reuses for irrigation and industrial customers. The Balboa Pump Station, located in the southeast corner of the plant property, is used to deliver recycled water to customers in the San Fernando Valley. The pump station consists of three 18 cubic feet per second (cfs), 1,000 hp pumps with provisions to add three more pumps.

The large majority of the recycled water is directed to the Japanese Garden Lake, Lake Balboa and the Wildlife Lake, which all ultimately flow to the Los Angeles River. This lake flow-through process helps to maintain water quality within the lakes to prevent odor problems, algae blooms and fish kills. Occasionally, intermittent overflows from a safety weir within DCTWRP discharge back into the sewer system or the Los Angeles River depending on operational needs. Table 5.18 summarizes the quantity of effluent water reuse, for a period of July 2014 to June 2015.

| Table 5.18 DCTWRP Average Effluent Water Reuse Wastewater Facilities Plan One Water LA 2040 Plan | |
|---------------------------------------------------------------------------------------------------------------------------------------------------------------------------------------------------------------|-----------------|
| Effluent Water Reuse | Value |
| Plant Water Reuse | |
| Japanese Gardens | 4.1 mgd |
| Lake Balboa | 15.0mgd |
| Wildlife Lake | 4.6 mgd |
| Operational Safety Weir | 5.6 mgd |
| Total | 29.3 mgd |
| <i>Source: Monthly Performance Reports July 2014 to June 2015.</i> | |
| Notes: | |
| (1) In-Plant Uses (HPE+LPE) averaged 2.9 mgd. Recycled Water to LADWP customers averaged 1.4 mgd | |
| (2) A minor difference between the chlorine contact tank influent flow (1 meter) and the summed (6 meters) water reuse flows was observed. This is likely a result of calibration variability between meters. | |
| (3) Minimum and maximum flow ranges for July 2014 to June 2015 are 13.3 mgd and 33.2 mgd, respectively. | |

5.1.12 Ancillary Facilities

There are a number of facilities at DCTWRP that are not a direct part of the process train. These facilities include the maintenance building, administration building, and personnel building.

5.1.13 Recent and Ongoing Plant Upgrades

A variety of projects at DCTWRP have been planned or are currently underway to increase the plant's overall reliability and efficiency. The following projects in Table 5.19 replaced, rehabilitated or upgraded process components at the plant and were in construction by

March 2017. Planned projects that begin construction after March 2017 are described in Section 5.5 and are listed in Appendix H. Planned completion dates are shown in parenthesis at the end of the description. Projects that have been completed are noted as such.

| Table 5.19 DCTWRP Recent and Ongoing Plant Upgrades Wastewater Facilities Plan One Water LA 2040 Plan | | | |
|----------------------------------------------------------------------------------------------------------------------|------------------|--------------------------------------------------|---------------------------------------------------------------------------------------------------------------------------------------------------------------------------------------------------------------------------------------------------|
| Process | Project # | Project Title | Description |
| Preliminary | 6197 | Grit Chamber Flush System | This project will install a backup flush system at the grit chamber. (12/2017) |
| Preliminary | 6215 | Phase 1 Bar Screens | This project will replace three Phase I bar screens with fully enclosed continuous rake bar screens, the same as those installed in Headworks II. (7/2019) |
| Preliminary | 6212 | Screw Pump Procurement | This project procured eight screw pumps and associated equipment. (Complete) |
| Preliminary | 6201 | Screw Pump Installation & Upgrades | This project will replace eight inlet screw pumps and associated equipment. It will also install condition sensors on all eight screw pump assemblies/ (4/2018) |
| Primary | 6225 | Primary Tanks & Secondary Clarifiers Guard Rails | The project replaced all removable guard rail support systems on the primary and secondary clarifier tanks. (Complete) |
| Primary | 6218 | Primary Sludge Withdrawal System | This project replaced the piping, controls, motors, and actuators associated with the sludge system. (Complete) |
| Primary | 8637 | Primary Tank HPE Piping Replacement | This project will replace the corroded HPE copper piping. (12/2019) |
| Process Air System | 6171 | Blower Air Cleanup System | This project will construct an air scrubbing system to remove harmful contaminants before air enters the blowers. This project will also install a new scrubber system and provide associated ductwork. The old blowers will be removed. (3/2018) |
| Final Clarifiers | 6207 | Secondary Clarifier Structural Steel Improvement | This project will rehabilitate the structural steel supports in the secondary clarifier tanks. (5/2019) |

| Table 5.19 DCTWRP Recent and Ongoing Plant Upgrades Wastewater Facilities Plan One Water LA 2040 Plan | | | |
|----------------------------------------------------------------------------------------------------------------------|------------------|------------------------------------------------------|-------------------------------------------------------------------------------------------------------------------------------------------------------------------------------------------------------------------------------------------------|
| Process | Project # | Project Title | Description |
| Filters | 1574 | Phase 2 Tertiary Effluent Meter Improvements | This project replaced the Phase 2 filter effluent meter. (7/2019) |
| Disinfection | 6210 | Chlorine Contact Tank Gate Actuators | This project will install motorized actuators on the chlorine contact gates. (5/2018) |
| Disinfection | 6226 | DCTWRP Chlorination System Improvements | This project will replace four chlorine storage tanks, the sodium hypochlorite piping system, and chemical diffusers. (5/2019) |
| Disinfection | 8649 | DCTWRP Chlorine Contact Tank HPE System Improvements | This project will replace the HPE pipe with PVC and ductile iron pipes and associated valve system. (12/2019) |
| Dechlorination | 6204 | Chemical Lines Upgrade | This project will relocate the sodium bisulfite chemical lines into a new trench and the ammonia hydroxide chemical lines above ground. It will also install a recirculation pump system on the sodium bisulfite chemical line. (2/2018) |
| Ancillary Facilities | 6214 | Administration Building HVAC Replacement | This project will replace the heating, ventilation, and air conditioning (HVAC) system. (12/2019) |
| Ancillary Facilities | 6145 | Backup Power | This project will provide emergency backup power so DCTWRP will not violate its NPDES permit in case the existing power feeders are lost. This project will also remove the existing emergency backup generator and underground tank. (12/2019) |
| Ancillary Facilities | 6163 | Electrical Power System Mods | This project will replace existing switchgear and reconfigure the current loop system to a more reliable configuration. (4/2018) |
| Ancillary Facilities | 8606 | Main Switchgear Air Conditioning System | This project will install a new air conditioning system in the existing electrical building to protect new switchgear. (6/2018) |

| Table 5.19 DCTWRP Recent and Ongoing Plant Upgrades Wastewater Facilities Plan One Water LA 2040 Plan | | | |
|------------------------------------------------------------------------------------------------------------------------------------------------------------------------------------------|------------------|------------------------------------------------|--------------------------------------------------------------------------------------------------------------------------------------------------|
| Process | Project # | Project Title | Description |
| Ancillary Facilities | 8650 | Japanese Garden Electrical System Improvements | This project will upgrade electrical panels located in the Japanese Garden as well as replace broken/missing path lights with new ones. (2/2019) |
| Ancillary Facilities | 8654 | Japanese Garden ADA Compliance | This project will result in Americans with Disabilities Act (ADA) compliance for the Japanese Gardens. (2/2019) |
| Ancillary Facilities | 8626 | LAB Building Roof Protection System | This project will build a Fall Protection System at the roof of the LAB Building. (9/2019) |
| Ancillary Facilities | 8638 | Niwa Road Sewer Installation | This project will install a sewer system at Niwa Road near the Japanese Garden. (12/2019) |
| <i>Sources: Wastewater Treatment Plants Master Schedule, City of Los Angeles Bureau of Engineering; Wastewater Capital Improvement Program, Clean Water Program, City of Los Angeles</i> | | | |

In addition to the listed improvements above, DCTWRP is currently undergoing a pilot program for the proposed Los Angeles Groundwater Replenishment Project (GWR).

5.2 IN-PROGRESS PROJECT

In-Progress projects are planned supply projects for groundwater, recycled water, and stormwater that are expected to be implemented outside and independent of the One Water LA 2040 Plan. For DCTWRP one In-Progress Project was identified and is described in Table 5.20 and this section.

| Table 5.20 DCTWRP In-Progress Project Wastewater Facilities Plan One Water LA 2040 Plan | | | |
|-----------------------------------------------------------------------------------------------------------------------------------------------------------------------------------------------------------------------------------------------------------------------------|----------------------------------------|---------------------------------------|---------------------------|
| Title | Type | Estimated Yield (Normal Year) | Capital Cost (\$M) |
| Groundwater Replenishment Project with Advanced Water Purification Facility (AWPF) at DCTWRP (up to 30,000 AFY in San Fernando Basin) | Potable Reuse Groundwater Augmentation | 30,000 AFY ⁽¹⁾ (27 mgd) | \$370 |
| Note: (1) Per Los Angeles Groundwater Replenishment Project EIR (May 2016), GWR AWPF will yield a total of up to 35,000 AFY of purified water, of which 5,000 AFY will be used for NPR uses and up to 30,000 AFY will be used for groundwater replenishment uses. | | | |

5.2.1 Project Description

While DCTWRP currently produces Title 22 recycled water for NPR, the City is conducting pilot testing at DCTWRP to provide advanced treated water for spreading. The GWR Project plans to purify recycled water for groundwater replenishment by building a new AWPF at DCTWRP. Recycled water pipelines would then convey purified water to the Hansen and Pacoima Spreading Grounds in the eastern San Fernando Valley to replenish the San Fernando Basin and its aquifers, and subsequent recovery via production wells.

The Hansen Spreading Grounds and Pacoima Spreading Grounds have capacity to recharge up to 19,000 AFY and 23,000 AFY of purified water, respectively. These quantities are based on the availability of supply and the capacity of the spreading grounds in a given year in relation to all potential sources of water. The GWR Project would provide up to 15,000 AFY of purified recycled water from DCTWRP for each spreading ground facility, for an estimated total spreading of up to 30,000 AFY. A phased implementation of the GWR project is currently planned. The GWR Project adopted its Final EIR in December 2016 after having released a draft for public review. Groundwater replenishment operations as a result of the GWR Project are planned to begin in 2023.

5.2.1.1 System Upgrades

For conveyance of the product water to recharge sites, this project would require additional infrastructure. A new 2-mile long, 42-inch diameter recycled water pipeline would need to be constructed to convey purified water to the Pacoima Spreading Grounds. Conveyance of purified water to the Hansen Spreading Grounds would utilize an existing 10-mile, 54-inch diameter recycled water pipeline. LADWP would utilize existing groundwater production wells for extraction.

5.2.1.2 DCTWRP AWPf

The AWPf will be required to purify recycled water produced by the existed DCTWRP recycled water treatment facilities. The AWPf would be located in the southeast corner of the DCTWRP complex on an approximate 1.75-acre vacant site. As detailed in the Los Angeles Groundwater Replenishment Project Draft Environmental Impact Report (May 2016), up to about 35,000 AFY (31.3 mgd) of purified water could be produced from the AWPf. The AWPf facility would utilize purification processes and technologies that could include ozonation, BAC, MF, RO, and AOP/NaOCl. Pilot testing is evaluating other processes/technologies for water quality, operational efficiencies, and cost effectiveness. Alternative processes or technologies, if feasible and selected for the AWPf, are not anticipated to require additional space or construction activity. Additionally, a portion of the existing disinfection contact tanks, which would not be required for recycled water treatment or advanced water purification, may be converted for ozonation and BAC processes. To operate the AWPf at a constant flow, as well as maximize production, this project includes an equalization tank for approximately 6.5 MG of influent storage capacity, located in the northeastern part of DCTWRP. The remainder of the plant processes do not require upgrades or changes with the implementation of this project. Diluent water is only needed for groundwater recharge if the volume of recharge recycled water exceeds a certain blend ratio with other waters.

Sizing of the GWR AWPf is based on the available influent for advanced treatment, per Los Angeles Groundwater Replenishment Project EIR, May 2016. Concept options presented in subsequent text may require expansion of the GWR AWPf. Table 5.21 summarizes the capacities for the planned GWR AWPf (Phase 1 and 2) and potential expansion associated with concept options.

| Table 5.21 AWPf Construction and Future Expansion Wastewater Facilities Plan One Water LA 2040 Plan | | |
|-----------------------------------------------------------------------------------------------------------------------------------------------------------------------------------------------------------------------------------------------------------------------------|----------------------------------------------------------|---------------------------------------------|
| Phase | Expansion (Year) | Total Capacity (mgd/AFY) |
| Phase 1 and 2 (GWR) | In Progress: Expected Completion 2023 | Up to 27 mgd (30,000 AFY) ⁽¹⁾ |
| DCTWRP Expansion | As needed; dependent upon selection of concept option | Up to 14 mgd (15,000 AFY) |
| <u>Note:</u> (1) Per Los Angeles Groundwater Replenishment Project EIR (May 2016), GWR AWPf will yield a total of up to 35,000 AFY of purified water, of which 5,000 AFY will be used for NPR uses and up to 30,000 AFY will be used for groundwater replenishment uses. | | |

5.2.1.3 Ozone Demonstration Project

The City also plans on implementing a demonstration project consisting of 7-10 mgd interim ozonation process to provide ozonated tertiary treated recycled water for spreading at the

Hansen Spreading Grounds. This demonstration project would provide data regarding soil aquifer treatment and aid in the development of a larger recharge program. These potential projects are depicted on Figure 5.4.

5.2.1.4 DCTWRP Potential Expansion

The City leases the land where DCTWRP is located from the US Army Corps of Engineers (USACE). As part of the planning efforts the City has identified expansion locations. These locations are shown on Figure 5.4.

5.3 FUTURE SYSTEM NEEDS EVALUATION

The previous section discussed DCTWRP's existing facilities, recent upgrades, and in-progress projects. In order to optimize plant operations and maximize water reuse potential, several future integration opportunities concept options for DCTWRP have been developed. This section discusses:

- Projected future flows and availability for water reuse
- Future integration opportunities (concept options) for DCTWRP
- Preferred approach

The preferred approach presented provides for multiple future scenarios based upon the occurrence of defined "trigger" events.

5.3.1 Flow Evaluation

In order to identify which options could be implemented at DCTWRP, an analysis of flows was performed to understand which flows are available for water reuse. This section discusses the current and projected influent and effluent flows, which are key in evaluating the future projects at DCTWRP.

5.3.1.1 DCTWRP Influent Flows

The major trunk sewers in the DCTWRP sewershed area include the VORS, the AVORS, and the EVIS. 2016 flows from these trunk lines to DCTWRP for treatment are estimated to be approximately 56 mgd on average. This value is higher than the 47 mgd reported as influent to DCTWRP because some flows are bypassed. Solids residuals resulting from DCTWRP treatment are discharged to HWRP along with bypassed wastewater, all of which are treated at the HWRP. Post-2016 flows assume that the flows by-passed to HWRP would be minimal, thus increasing the potential influent at DCTWRP.

Document Path: \\usnr\1s07\GIS\Jobs\City_LA_BOS\MXD\OneWater_LA2040Plan\WRP\DCTWRP_ExpansionArea_LtrL_20170914.mxd

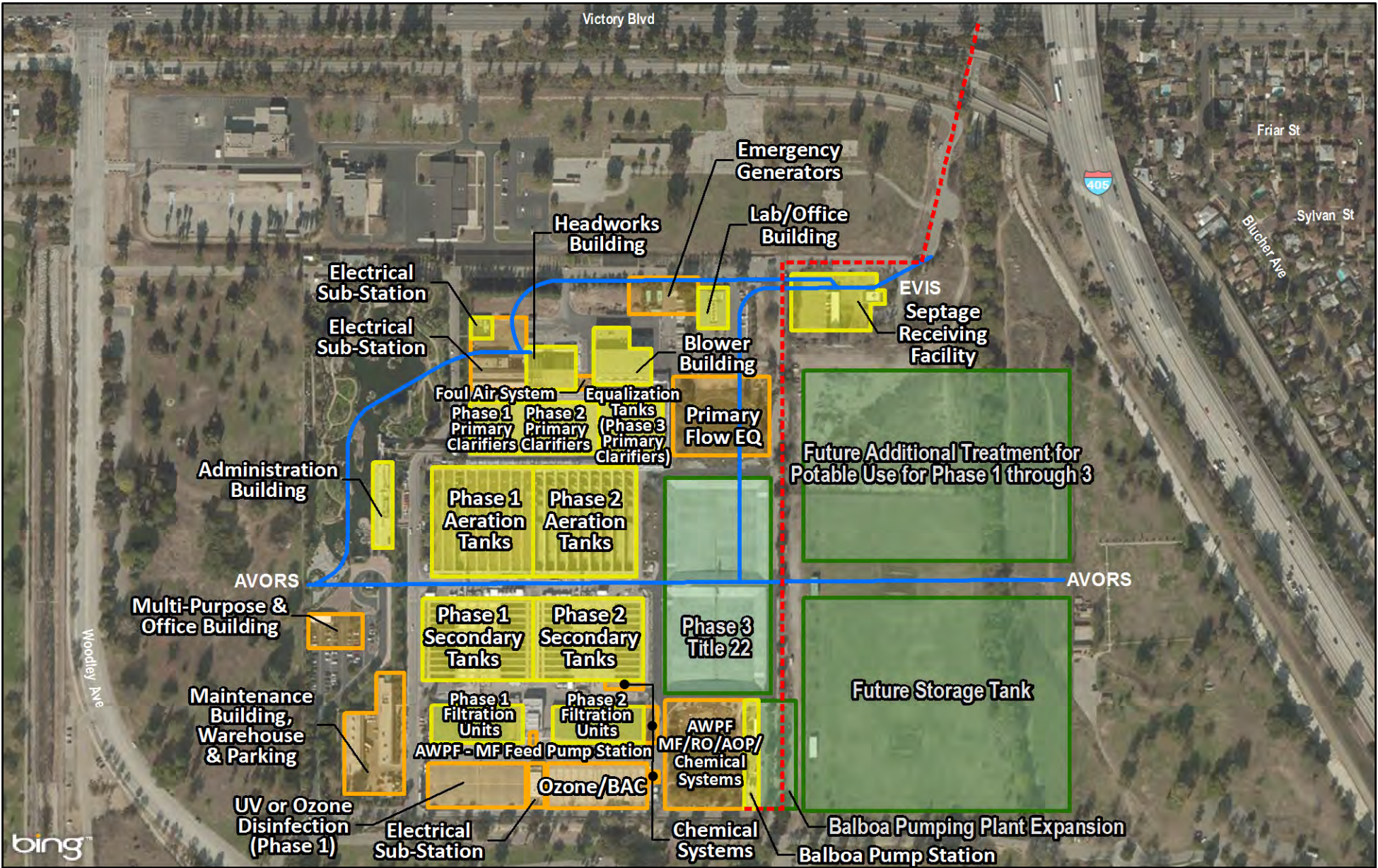

- - - Proposed Brine Line
- AVORS and EVIS
- Existing Facility
- Year 2025 Facility
- Long Term Expansion



Figure 5.4
DCTWRP Future Expansion Plan
 One Water LA 2040 Plan

Dry and Wet Weather Flow Diversion

Implementation of dry weather low flow diversions could increase flow up to 2 mgd. If EWVIS is constructed, additional dry weather flows could be conveyed, on the order of 1.4 mgd. Wet weather flow diversions could bring an additional 0.5 mgd (increasing up to 0.6 mgd after EWVIS) to DCTWRP. Increase in flows, and as a result additional treatment at DCTWRP, will increase the quantity of solids (and brine in the long term) discharged to HWRP. Table 5.22 shows the total projected influent flows for DCTWRP, combining dry weather flow diversions and projected wastewater influent, for the One Water LA 2040 Plan planning horizon.

| Table 5.22 DCTWRP Projected Wastewater Flows Wastewater Facilities Plan One Water LA 2040 Plan | | | | |
|--------------------------------------------------------------------------------------------------------------------------------------------------|---------------------------------------------------------|---------------|---------------|---------------|
| Source | Projected Wastewater Flows by Year⁽¹⁾ | | | |
| | 2016 | 2020 | 2030 | 2040 |
| Wastewater Influent ⁽²⁾ | 47 mgd | 46 mgd | 49 mgd | 51 mgd |
| Future Dry Weather LFDs ⁽³⁾ | - | - | 2 mgd | 2 mgd |
| Totals⁽⁴⁾ | 47 mgd | 46 mgd | 51 mgd | 53 mgd |
| Notes: | | | | |
| (1) mgd = million gallons per day | | | | |
| (2) Wastewater Influent values reflect Normal Year hydrological conditions. Additional details of these projected flow values are found in TM2.1 | | | | |
| (3) Future planned LFDs are included in these future flow projections. These LFDs are assumed to be implemented starting in Year 2030. | | | | |
| (4) Flows are rounded to the nearest mgd. | | | | |

5.3.1.2 DCTWRP Planned Water Reuse

DCTWRP currently produces Title 22 tertiary effluent for a number of water reuse systems, including in-plant use, Japanese Garden, Balboa and Wildlife Lakes beneficial water reuse, non-potable reuses for irrigation as well as industrial customers. However, increased influent to DCTWRP would allow for additional potential water reuse of flows. The current In-Progress GWR Project will include an AWPf yielding purified water for groundwater recharge at the Hansen and Pacoima Spreading Grounds and ultimately more water supply for additional NPR and potential potable reuse with treated water augmentation demands.

5.3.1.3 Concept Option Flow Assumptions

As shown in Table 5.23, additional flows (such as those conveyed by EWWIS) may be needed for implementation of the full capacity of GWR. The flows available for reuse are within the range of 20-38 mgd. This is substantially less than the average flow of 53 mgd listed in Table 5.22 because flows are already allocated, as identified in Table 5.23 and Figure 5-5.

| Table 5.23 DCTWRP Flow Assumptions Wastewater Facilities Plan One Water LA 2040 Plan | |
|----------------------------------------------------------------------------------------------------------------------------------------------------------------------------------------------------------------------------------|------------------------------|
| Flow Component | Flow (mgd) |
| DCTWRP 2040 Project Influent Flow | 53 |
| Existing Non Potable Reuse | -2 |
| Additional Non Potable Reuse | -2 |
| In-Plant Uses and Lakes ⁽¹⁾ | -26.6 ⁽³⁾ to -8.6 |
| Waste flow to HWRP | -2 |
| Range of Available Flows for Water Reuse (without GWR) | 20-38 |
| GWR Phase 1 ⁽²⁾ | -27 |
| Brine Loss from Advanced Water Purification Facility ⁽²⁾ | -9 |
| Range of Additional Flow Diversion Needed (with GWR) | 0-16 |
| Note: | |
| (1) This value could be reduced from 26.6 mgd to as low as 8.6 mgd through implementation of Concept Option #26 (Japanese Garden & Sepulveda Basin Lakes Recirculation). | |
| (2) Implementation of the GWR AWPf may require the diversion of additional flow to DCTWRP. For this reason, the flow allocated for these items (total of 36 mgd) has not been deducted from the available flows for water reuse. | |
| (3) This is the average flow from July 2014 to June 2015. Flow range from 10.8 mgd to 32.3 mgd during the same period. | |

For planning purposes it was assumed that approximately 14 mgd could be diverted to DCTWRP and therefore 14 mgd (15,000 AFY) was estimated to be the remaining flow available at DCTWRP for water reuse. This value was used for the sizing of facilities and equipment that may be need for each concept option, as discussed in greater detail in Volume 5. The concept options are preliminary in nature as the projects remain at a high level and further evaluation will be required should a concept option be implemented.

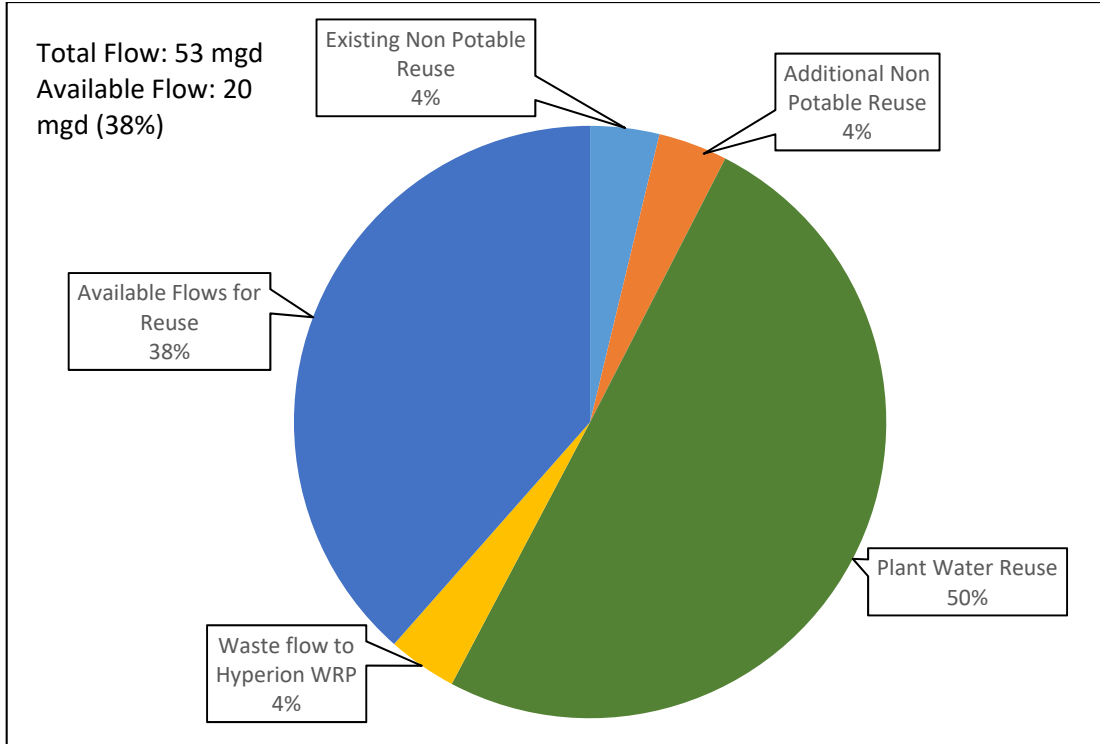

Figure 5-5 Estimated Flow Availability for Water Reuse from DCTWRP (2040 Projection)

5.3.2 Concept Options Development

The preliminary list of concept options that support a locally sourced water supply was developed through workshops that solicited ideas and input from a workgroup as well as community stakeholders. This workgroup included contributors from an array of communities, LASAN, LADWP, other City Bureaus and Departments and select technical advisors. These ideas resulted in the development of concept options within the 2040 planning horizon. Concept options represent new concepts that have not been previously evaluated by the City.

With this methodology, a list of 27 concept options was developed for the entire system. Of these 27 concept options, six concept options were related to DCTWRP. Determination of the plant's future system needs were based on previous master plans, planning documents, discussions with City staff, and brainstorming sessions. Specifics related to these concept options can be found in Appendix D. Concept options are preliminary in nature and are not a commitment to level or quantity of treatment. Table 5.24 shows the concept options associated with DCTWRP, including the normal year yield, associated capital costs, and unit costs.

| Table 5.24 DCTWRP Concept Options Wastewater Facilities Plan One Water LA 2040 Plan | | | | | |
|----------------------------------------------------------------------------------------------------------------------------------------------------------------------------------------------------------------------|-------------------------------------------------------------|--------------------------------------------------|--------------------------------------|-----------------------------------------|--------------------------|
| Concept Option # | Title | Strategy | Estimated Yield (Normal Year) | Capital Cost (\$M)⁽¹⁾ | Unit Cost (\$/AF) |
| 7 | Upper Los Angeles River to Tillman WRP | LA River Storage and Use | 5,600 AFY (5 mgd) | \$18 | \$160 |
| 9 | Tillman WRP to San Fernando Basin Injection Wells | Potable Reuse with Groundwater Augmentation | 15,000 AFY (14 mgd) | \$360 | \$1,600 |
| 15 | Tillman WRP to Los Angeles Aqueduct Filtration Plant | Potable Reuse with Raw Water Augmentation | 15,000 AFY (14 mgd) | \$310 | \$1,500 |
| 16 | Tillman WRP to LADWP Distribution System | Potable Reuse with Treated Water Augmentation | 15,000 AFY (14 mgd) | \$295 | \$1,300 |
| 22 | East-West Valley Interceptor Sewer | Flow Management | 12,800 AFY (11.41 mgd) | \$85 | \$430 |
| 26 | Japanese Garden & Sepulveda Basin Lakes Recirculation | Flow Management | 20,000 AFY (18 mgd) | \$20 | \$70 |
| <u>Note:</u> | | | | | |
| (1) Total Concept Option cost includes a variety of project components including treatment facilities, conveyance, and injection and extraction facilities. Not all costs pertain to the Wastewater Facilities Plan. | | | | | |
| (2) Bold indicates a Priority A Concept Option | | | | | |

As shown in Table 5.24, the concept options for DCTWRP involved flow management and one of the three water reuse strategies or flow management strategy:

- Potable reuse with groundwater augmentation - Projects that would spread (infiltrate) or directly inject recycled water into a groundwater basin that could be used as potable water after extraction and further treatment.
- Potable reuse with raw water augmentation prior to delivery - Projects that would deliver advanced treated recycled water (purified water) to a conventional water treatment plant before distributing into a potable water system.
- Potable reuse with treated water augmentation prior to delivery into the potable water distribution system - Projects that would deliver advanced treated recycled water (purified water) directly to a potable water system.

While there are differences between the options in terms of capacity, delivery location and ultimate use, all require similar levels of advanced treatment.

5.3.3 Preferred Approach

As part of the WWFP development, each of the concept options listed above was reviewed to identify improvements that would need to be implemented at the plant as well as system changes to convey that product water. This analysis included preliminary sizing of treatment process modifications, location of the processes, and preliminary cost estimates. Based on the overall concept score, cost estimates, and portfolio evaluation results, the concept options were prioritized. As the flows from each plant can only be utilized once, it is important to identify what the most beneficial method of water reuse. However, implementing many concept options are dependent upon the occurrence certain "triggers" events, such as regulatory changes or new institutional arrangements.

As a result, the highest scoring concept option may not be viable depending on which triggers may or may not occur in the future. To guide the City with prioritization and the decision-making process related to these long-term water reuse options, a trigger-based implementation strategy was developed.

Figure 5.6 graphically depicts the triggers and the priority of implementation. The most preferred concept option is indicated as "Priority A", while the next best concept option is identified as "Priority B" and third best as "Priorities C & D".

The most critical trigger of any of the Priority A, B, or C options is the ability to increase recycled water flow availability to DCTWRP. Due to the success of water conservation and the ongoing groundwater replenishment project, all existing flows have been accounted for. Hence, the first trigger is a decision to pursue and implement a flow management project to divert additional wastewater flows to DCTWRP. Once the City makes this decision, the next trigger is the approval of a wastewater change petition from the Division of Water Rights per Water Code Section 1211 to allow a reduction in effluent discharge from DCTWRP to the LA River.

If this petition is approved, the City could proceed with Concept Option #26. By implementing some type of flow recirculation project for the Japanese Garden and Sepulveda Basin Lakes, a portion of the DCTWRP effluent that is currently discharged into the LA River could be repurposed for potable reuse.

If this petition is not approved, the City would need to proceed with Concept Option #22 and increase flow availability to DCTWRP by constructing the EWVIS project, which consist of a 6-mile sewer forcemain and six lift stations to bring wastewater flows from the eastern part of the San Fernando Valley to DCTWRP.

The next most critical triggers are related to the adoption of potable reuse regulations. The highest ranked potable reuse opportunity (Concept Option #15 - DCTWRP to Los Angeles Aqueduct Filtration Plant [LAAF]) would require acceptance of potable reuse with raw water augmentation, while the second highest concept option (#16 - DCTWRP to Distribution System) would require acceptance of potable reuse with treated water

augmentation. In case the potable regulations are not accepted within a desired timeframe or if the City prefers a more conventional form of water reuse, the third best potable reuse option from DCTWRP is Concept Option #9 (Groundwater Augmentation from DCTWRP to San Fernando Basin Injection Wells). If none of the flow management strategies are feasible nor the potable reuse regulations are approved, it is recommended to postpone any new water recycling projects from DCTWRP. This decision is indicated as "No Change" on Figure 5.6.

Donald C. Tillman Water Reclamation Plant

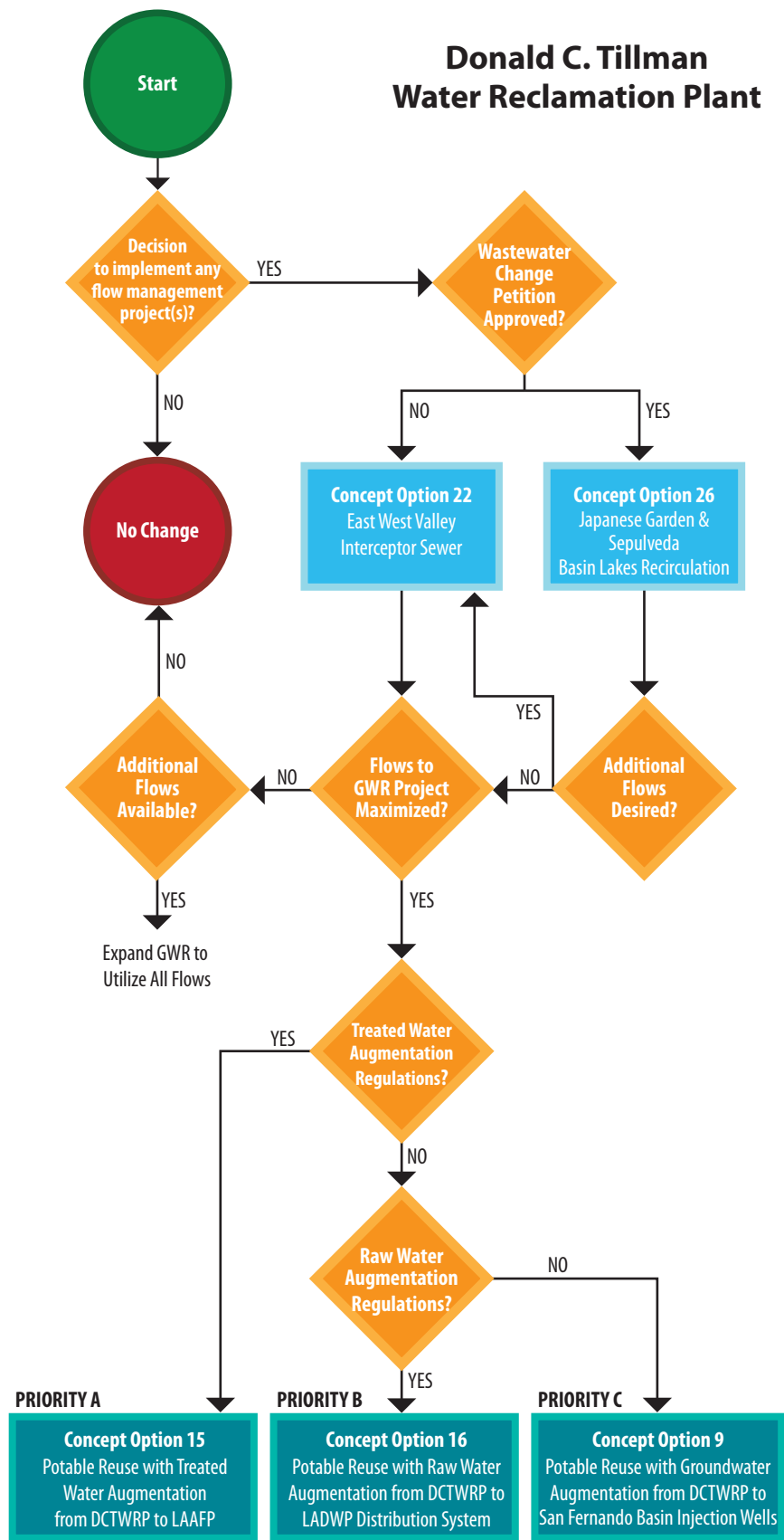

LEGEND & ACRONYMS

- ◆ Trigger
- Concept Option
- Flow Management Option

DCTWRP Donald C. Tillman Water Reclamation Plant
 GWR Groundwater Replenishment Project
 HWRP Hyperion Water Reclamation Plant
 LAGWRP LA-Glendale Water Reclamation Plant
 RWQCB Regional Water Quality Control Board
 TIWRP Terminal Island Water Reclamation Plant
 WRD Water Replenishment District of Southern California

Disclaimer: At each trigger (decision point), evaluate all triggers and concept option priorities to consider changed circumstances in the future.

Figure 5.6
Trigger-Based Implementation Strategy for DCTWRP
 One Water LA 2040 Plan
 Summary Report

5.3.4 Concept Option #15 (DCTWRP to LA Aqueduct Filtration Plant)

The DCTWRP currently produces recycled water for non-potable water uses. As part of the In-Progress GWR Project, an AWPf is planned to be built at the DCTWRP to provide full advanced treatment. From the DCTWRP AWPf, treated water meeting potable reuse with raw water augmentation standards would be pumped to the LAAFP. This concept would include expansion of the AWPf facilities and additional processes likely required to comply with anticipated future potable reuse with raw water augmentation regulations. This concept option is estimated to yield 15,000 AFY (14 mgd) of advanced treated water during normal, wet, and dry years. The expected timeline for the implementation would be between 2035 and 2040. Figure 5.7 shows the overall process concept flow schematic for this concept.

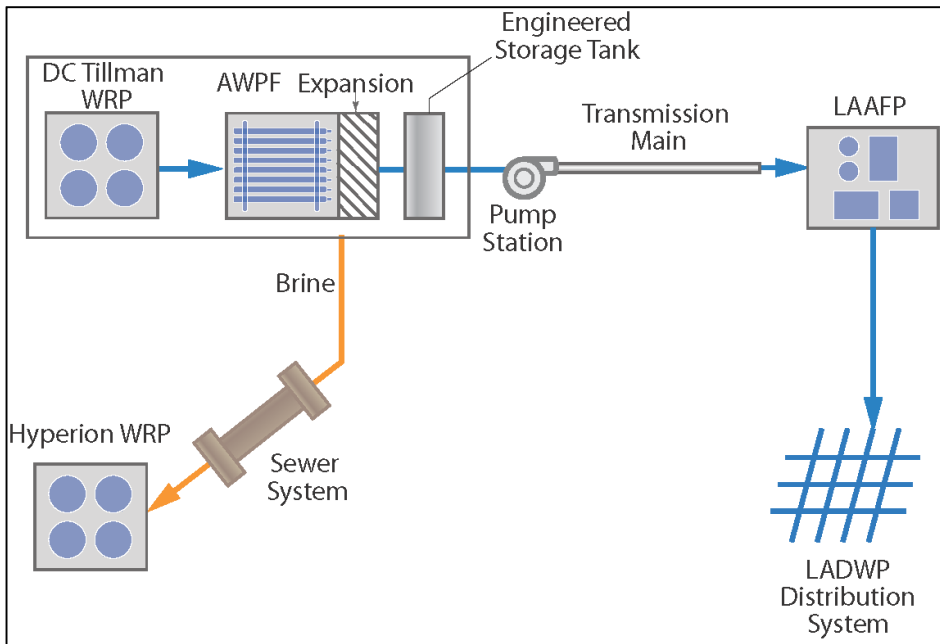
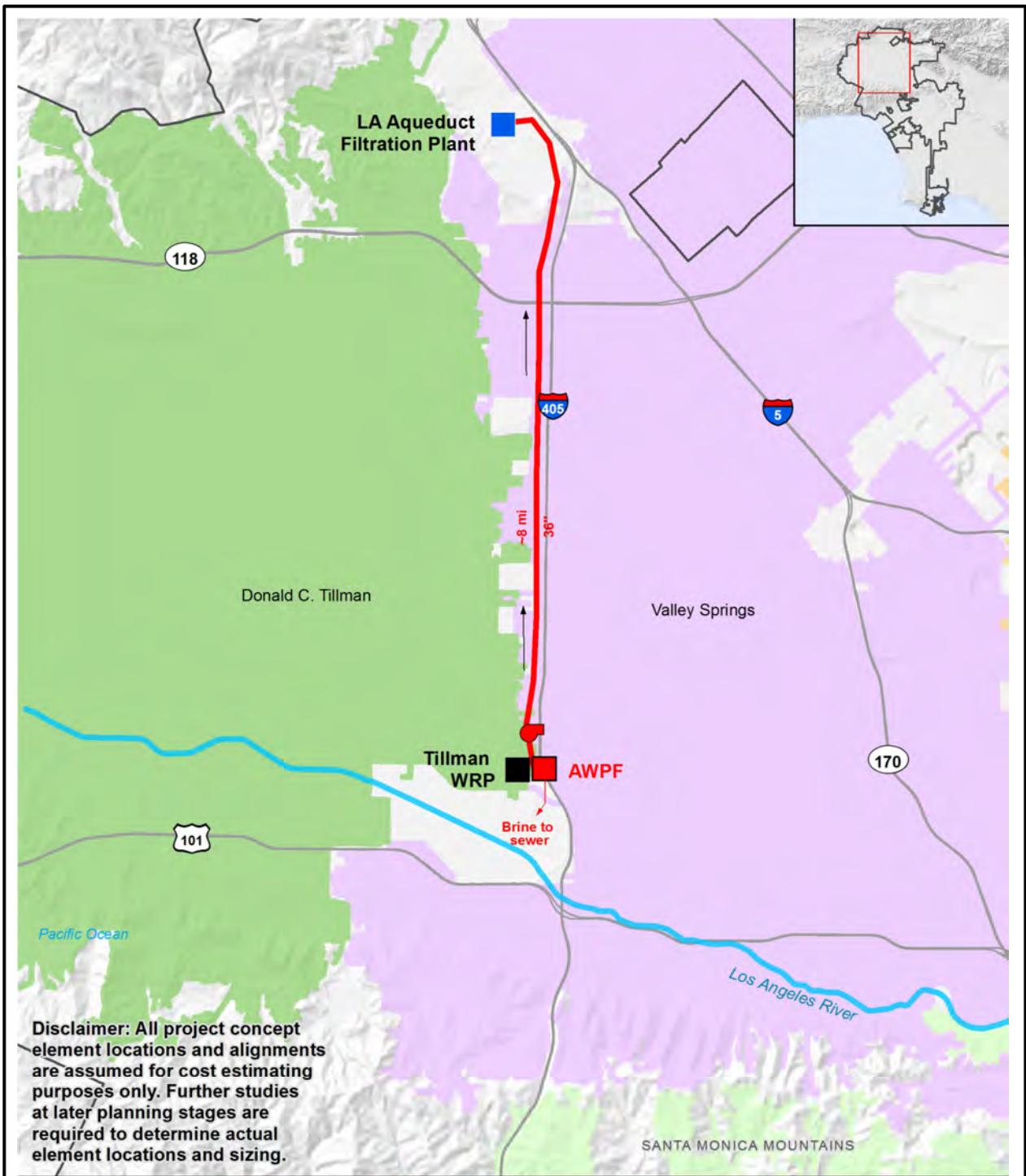

Figure 5.7 Process Flow Schematic Concept Option #15 (DCTWRP to LAAFP)

5.3.4.1 System Upgrades

Additional system upgrades for this concept option may include a pump station and transmission pipeline to convey the water from the AWPf to the LAAFP. Table 5.25 summarizes the potential system upgrades that may be needed for implementation. Figure 5.8 shows the system aerial map.

| Table 5.25 System Upgrades for Concept Option #15 (DCTWRP to LAAFP) Wastewater Facilities Plan One Water LA 2040 Plan | |
|--------------------------------------------------------------------------------------------------------------------------------------|---------------------------|
| Description | Quantity |
| Estimated Yield (Wet/Normal/Dry) | 15,000 AFY (14 mgd) |
| Pump Station | 1 in quantity, 2,500 hp |
| Transmission Pipeline | 8 miles, 36-inch diameter |



Legend

- Existing Water Reclamation Plant (WRP)
- Existing Water Filtration Plant (WRP)
- Advanced Water Purification Facility (AWPF)
- City of Los Angeles
- Flow direction
- Pump Station
- Pipeline
- Brine
- Groundwater Basin Source: LACDPW

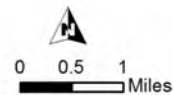

Hillshade Source: CalAtlas
<http://www.atlas.ca.gov>

Figure 5.8
System Upgrades for Concept Option #15 (DCTWRP to LAAFP)
 One Water LA 2040 Plan

5.3.4.2 DCTWRP Upgrades

Implementation of this concept may require an expansion of the GWR AWPf. This project would yield 15,000 AFY (14 mgd) of purified water, with solids discharged downstream to the existing sewer system for treatment at the HWRP. In addition to increased capacity of the AWPf, any additional processes likely required to comply with future anticipated potable reuse raw water augmentation regulations would need to be added to DCTWRP. These processes are unknown as the regulations are in development. A 2 MG tertiary effluent equalization tank may also need to be added upstream to the AWPf expansion in order to operate the processes at a constant flow. Table 5.26 summarizes the influent, estimated yield, and brine quantities associated with the planned GWR AWPf and the necessary expansion.

| Table 5.26 Potential Upgrades Concept Option #15 (DCTWRP to LAAFP) Wastewater Facilities Plan One Water LA 2040 Plan | | | |
|------------------------------------------------------------------------------------------------------------------------------------------------------------------------------------------------------------------------------------------------------|------------------------|--------------------------|-------------------------------|
| Facility | Influent | Estimated Yield | Brine/Solids to DCTWRP |
| GWR AWPf | 45,000 AFY (44 mgd) | 35,000 AFY (31.3 mgd) | 10,000 AFY (9 mgd) |
| AWPF Expansion | 19,000 AFY (17 mgd) | 15,000 AFY (14 mgd) | 4,000 AFY (3 mgd) |
| Note: (1) Per Los Angeles Groundwater Replenishment Project EIR (May 2016), GWR AWPf will yield 35,000 AFY of purified water, of which 5,000 AFY will be used for NPR uses and 30,000 AFY will be used for groundwater replenishment uses. | | | |

Preliminary design criteria yielding an approximate footprint needed is shown in Table 5.27. The implementation of this concept will need to coincide with the planning efforts conducted with the USACE. As discussed previously potential expansion location have been identified and are shown on Figure 5.9. This figure is repeated for clarity.

The key benefits associated with this concept option consist of:

- Expands use of potable reuse with raw water augmentation
- Increases DCTWRP’s water reuse flows

Moreover, this concept option helps fulfill the following One Water key objectives and guiding principles:

- Implement, monitor, and maintain a reliable wastewater system
- Improve local water supplies reliability
- Integrate management of water resources and policies
- Increase climate resilience

| Table 5.27 Design Criteria for Concept Option #15 (DCTWRP to LAAFP) Wastewater Facilities Plan One Water LA 2040 Plan | | |
|-------------------------------------------------------------------------------------------------------------------------------------------------------------------------------------------------------------------------------------------|--------------|-----------------|
| Description | Units | Quantity |
| Tertiary Effluent (Feedwater) | mgd | 17 |
| Ozone Dose | mg/L | 10 |
| Generator Size | lbs/day | 730 |
| Generator Number | | 2+1 |
| Generator Footprint | sq ft | 2,700 |
| Ozone Contactor | Serpentine | |
| Number | | 2+1 |
| Ozone Contactor Footprint | sq ft | 2,700 |
| Ozone gas concentration | % | 12 |
| Days of Storage | days | 7 |
| Required Storage | lb | 86,000 |
| Required Storage | gallons | 9,100 |
| LOX Tanks | quantity | 2 |
| Configuration | Horizontal | |
| Tank Size | gallons | 4,000 |
| LOX Footprint | sq ft | 870 |
| BAF Filters | quantity | 2+1 |
| BAF Permeate Flow ⁽¹⁾ | mgd | 17 |
| BAF Footprint | sq ft | 5,000 |
| MF/UF Permeate Flow ⁽²⁾ | mgd | 16 |
| MF/UF Footprint | sq ft | 8,000 |
| RO / UV/AOP Permeate Flow ⁽³⁾ | mgd | 14 |
| RO / UV/AOP Footprint | sq ft | 14,000 |
| Chemical Facility Footprint | sq ft | 6,000 |
| Notes: | | |
| (1) Losses due to BAF are assumed to be minimal | | |
| (2) MF Recovery is assumed at 93% | | |
| (3) RO Recovery is assumed at 85% | | |
| (4) MF and RO recovery rates are consistent with Los Angeles GWR EIR, May 2016 | | |
| (5) Process sizing is based off assumptions in Chapter 2 and the San Diego PureWater Program which has a similar process train. | | |
| (6) Footprint sizes are estimated based on general process, electrical and instrumentation equipment that would be required. These estimates are conservative and would be further refined during detailed design upon project selection. | | |

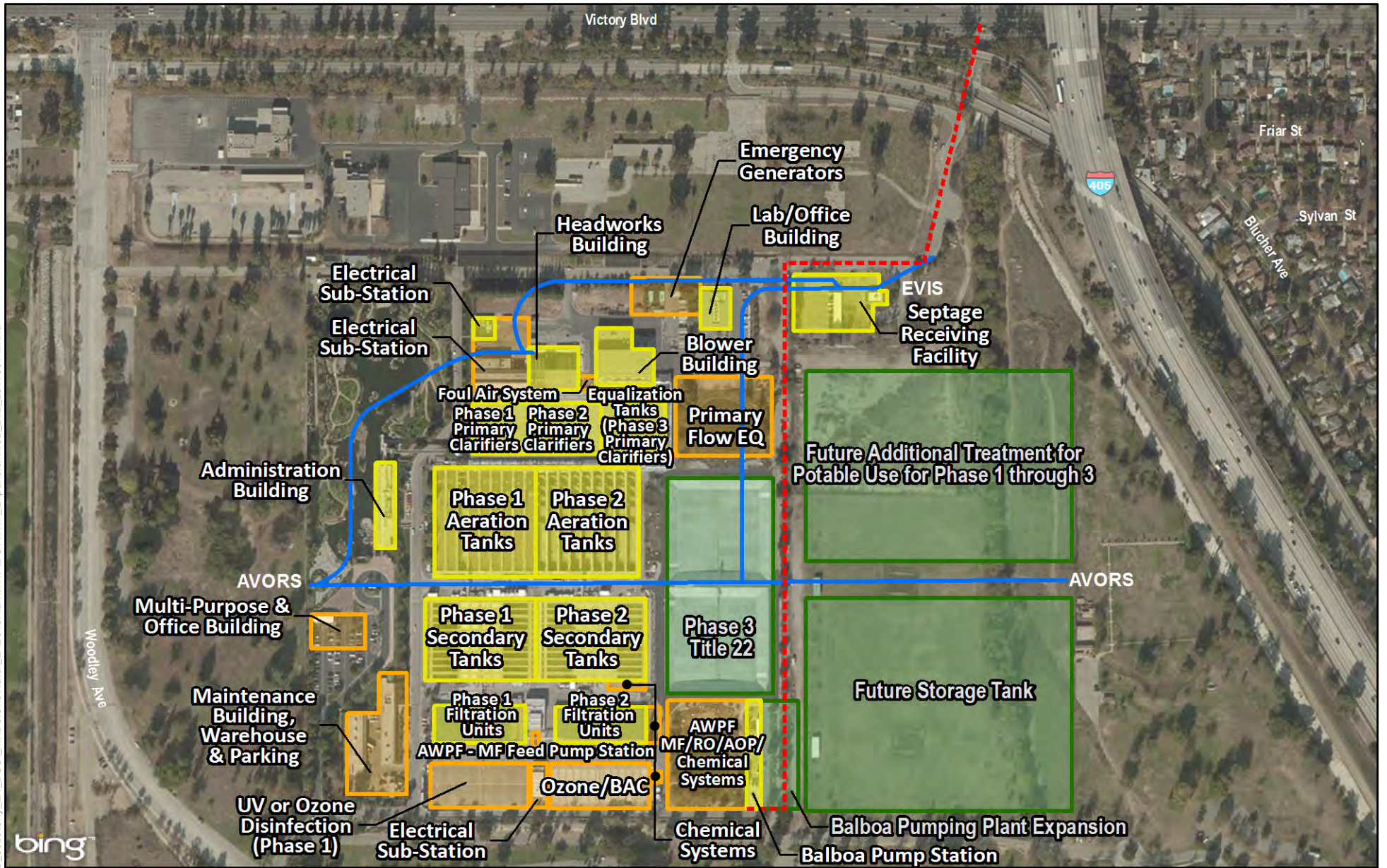

- - - Proposed Brine Line
- AVORS and EVIS
- Existing Facility
- Year 2025 Facility
- Long Term Expansion



Figure 5.9
Potential Upgrades for
Concept Option #15
(DCTWRP to LAAFP)
 One Water LA 2040 Plan

5.3.5 Concept Option #22 (East West Valley Interceptor Sewer)

Much of the wastewater flow from the East San Fernando Valley is currently diverted to DCTWRP. The EWVIS consist option would consist of a series of lift stations and a force main that would instead convey those flows to DCTWRP. The force main would need to vary in diameter from 24 to 42 inches, totaling 6 miles in length. The force main would require a total of 6 lift stations. Figure 5.10 shows the flow schematic for EWVIS, depicting the sewer pipelines that would no longer convey flow to DCTWRP.

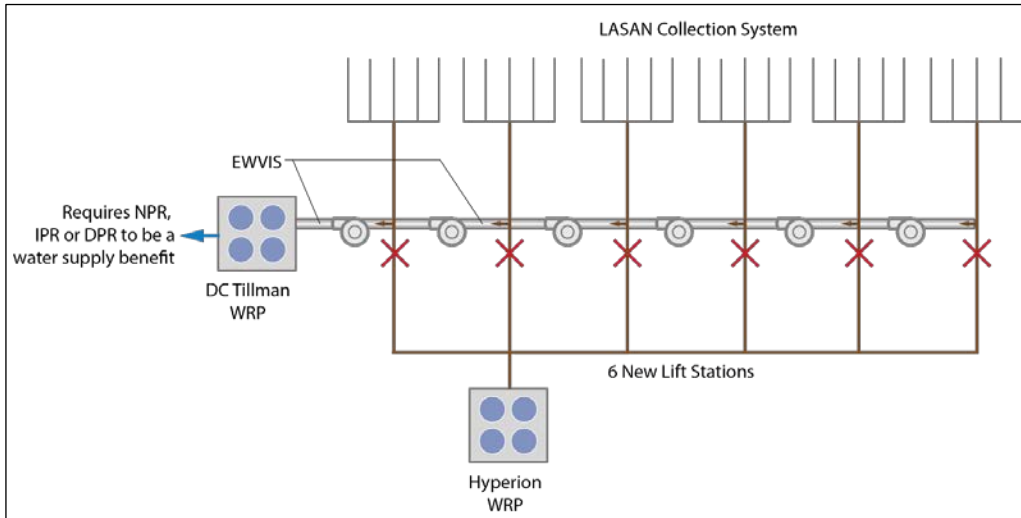
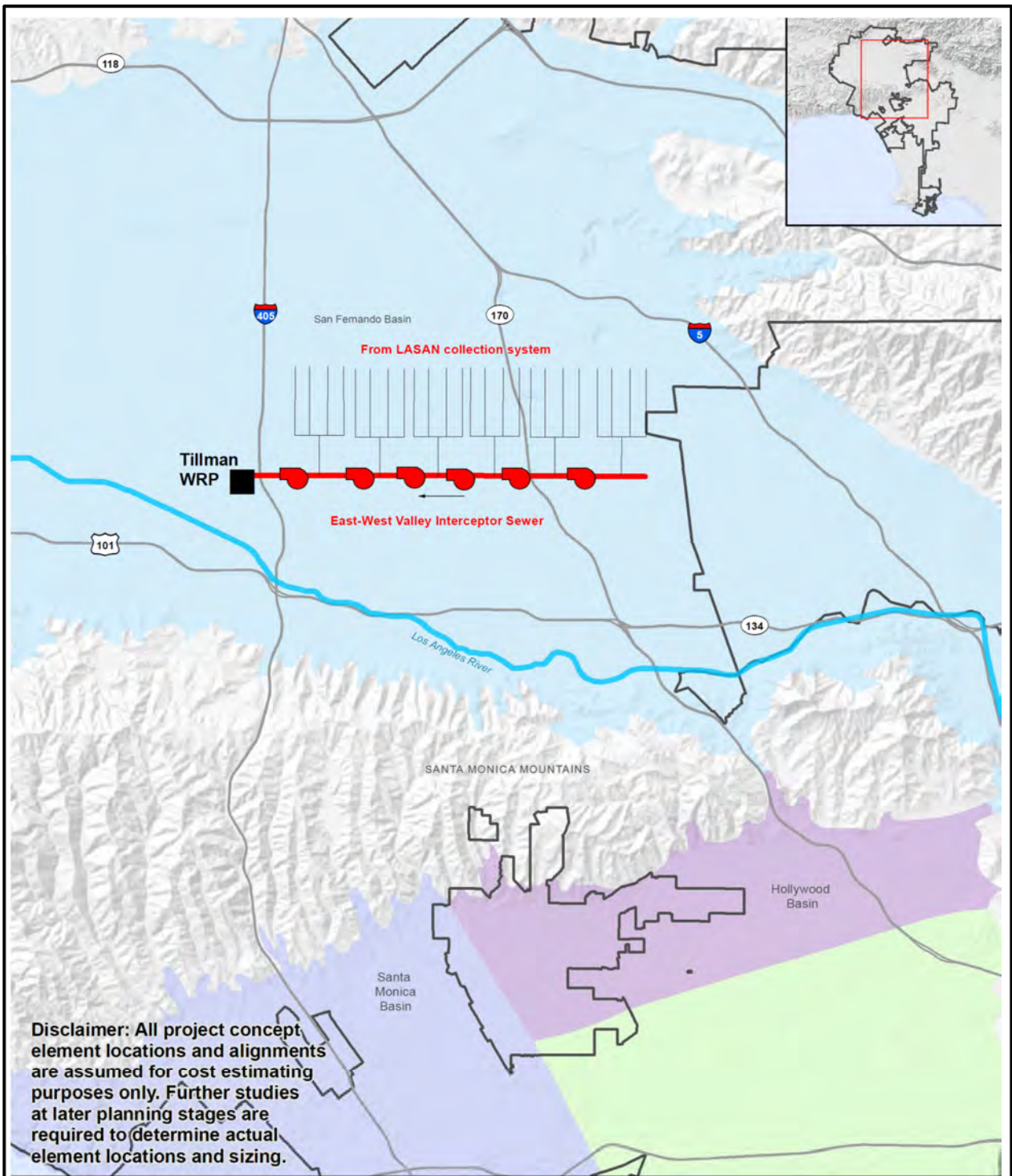

Figure 5.10 Process Flow Schematic for Concept Option #22 (EWVIS)

5.3.5.1 System Upgrades

Implementation of this project would primarily involves lift stations, diversion structures, and varying pipelines. Conveyance upgrades could consist of 6 miles of force main pipelines, varying in diameter from 24-inch to 42-inch. Six diversion structures and sewer bypass would likely be needed to divert flows into the new sewer line. Additionally, six new lift stations would be needed to pump the water to DCTWRP. Table 5.28 provides a summary of the yield in addition to system requirements. Figure 5.11 shows the system aerial map for this concept option.

| Table 5.28 System Upgrades for Concept Option #22 (EWVIS) | |
|------------------------------------------------------------------|------------------------------|
| Wastewater Facilities Plan | |
| One Water LA 2040 Plan | |
| Description | Quantity |
| Estimated Yield (Normal/Wet/Dry Year) | 12,800 AFY (11.4 mgd) |
| Force Main | 6 miles, 24-42 inch diameter |
| Diversion Structure | 6 in quantity |
| Lift Station | 6 in quantity |
| Flow Velocity (at peak dry weather) | 5 to 7.5 fps |
| Minimum Flow Velocity | 3 fps |
| Maximum Flow Velocity | 10 fps |



Legend

- Existing Water Reclamation Plant (WRP)
- City of Los Angeles
- Sewershed
-
-
-
-
-
- Sewer
- Collection system
- Lift Station
- Flow direction

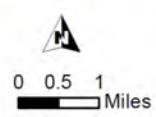

Hillshade Source: CalAtlas
<http://www.atlas.ca.gov>

Figure 5.11
System Upgrades for Concept
Option #22 (EWWIS)
 One Water LA 2040 Plan

5.3.5.2 DCTWRP Upgrades

EWVIS would provide sufficient flows to operate Phase 1 and 2 of DCTWRP at the current plant design capacity of 80 mgd. The AWPf designed for the GWR Project would be sufficient to handle the diverted flows from EWVIS. Hence, no potential upgrades for DCTWRP would be needed for implementation of this concept option. The key benefit associated with Concept Option #22 (EWVIS) includes:

- Maximizes City water reclamation plants' available treatment, recycling, and potable reuse capacity (i.e. direct water where it is needed) by redirecting wastewater from one sewershed to another.

Moreover, this concept option helps fulfill the following One Water key objectives and guiding principles:

- Implement, monitor, and maintain a reliable wastewater system
- Improve local water supplies reliability

5.3.5.3 Additional Projects for Consideration

In addition to the concept options presented, this sections summarizes projects that could also be considered in the future. Table 5.29 summarizes these projects.

| Table 5.29 Additional Project for Consideration Wastewater Facilities Plan One Water LA 2040 Plan | |
|------------------------------------------------------------------------------------------------------------------|-----------------------------------------------------------------------------------------------------------------------------------------------------------------------------------------------------------------------------------------------------------------------------------------------------------------------------------------------------------------------------------------------------------------------------------------------------------------------------------------------------------------------------------------------------------------------------------------------------------------------------------------------------------------------------------------------------------------------------------------------------------------|
| Process | Project Description |
| Collection System | Implement Sewer Monitoring and Routing Terminal (SMART Sewer) that will be a system of flow monitoring or sewer d/D recordings at key stations with the resulting data utilized in a near real time model to determine available sewer capacity such that wet weather storm flows could be routes or diverted into the collection system at controlled interconnections. All of these actions would be monitored and controlled at a central terminal. This is a sewer system inflow strategy to control stormwater flows in sewers and utilize available capacity for flow equalization. Continued control of sulfides to protect the integrity of concrete sewers and monitoring of critical points in consideration of low flows due to conservation. |
| Brine Disposal | Conduct a brine disposal technology evaluation, such as brine crystallizers or concentrators, to minimize the brine going to HWRP. |
| General | Perform Plant Optimization Study to identify biggest costs to DCTWRP. LASAN should continue their research and product evaluation to identify new technologies that will minimize power and chemical usage throughout the plant. |

These projects are preliminary in nature and a scope would need to be developed should LASAN staff decide to evaluate them further.

5.4 CLIMATE RISK AND RESILIENCE ASSESSMENT

Climate change is projected to impact the City's wastewater and stormwater systems in a variety of ways. The wastewater systems consist of sewer systems, sewage pumping facilities, wastewater treatment facilities and water reclamation facilities. Changes in temperature, precipitation, and sea levels will affect the physical plant and operational vulnerabilities of these facilities and operations.

A climate risk and resilience assessment was performed consisting of scenario development, screening analyses, site visits, risk analyses, and adaptation planning concurrent with meetings with LASAN staff. Current and potential future climate conditions were incorporated into the assessment and development of recommendations. Subsequently, practical improvements for the WRPs were identified to mitigate these risks.

A detailed description of the climate risk assessment of DCTWRP is included in Chapter 10, while the findings and recommendations are summarized in this section.

DCTWRP is located in the Sepulveda Flood Control Basin administered by USACE. Climate change conditions of increasing temperatures and changes in rainfall may affect power supply and flooding hazards, causing more frequent power interruptions at DCTWRP. Assessments were performed to understand the flooding and power failure risks associated with climate change considerations to identify resilience improvements that address these risks. The overall current and future climate hazards risk assessment for DCTWRP is low upon implementation of the planned flood protection and power improvements. The conceptual construction costs of these planned improvements are as follows:

- Add backup power generation for the critical load - \$7,712,900
- Raise protective berms and add structures and gates - \$4,500,000

No additional capital or non-capital resilience improvements are recommended for DCTWRP at this point in time. Other climate change considerations may be assessed in the future.

5.5 DCTWRP ADAPTIVE CIP

A summary level wastewater facilities Capital Improvement Plan (CIP) has been developed for all four WRPs and the collection system, located in Chapter 11 of this Volume. The purpose of this section is to summarize the capital improvement projects identified for DCTWRP. The sources used to develop the summary CIP include the Los Angeles Bureau of Engineering (LABOE) Uniform Project Reporting System (UPRS), LASAN Wastewater

Capital Improvement Plan (WCIP), LADWP 2015 UWMP, and concept options developed as part of the One Water LA 2040 Plan.

The development of the DCTWRP Adaptive CIP compiles the projects previously discussed in this chapter with the WCIP developed by the City. The projects for DCTWRP are classified as follows:

- In-Progress Projects
- Future integration opportunities (concept options)
- Estimated and Projected CIP

The costs for Estimated and Projected CIP are presented by category and phase, defined in Table 5.30. Project costs are then summarized and escalated based upon implementation schedule. The CIP for DCTWRP represents one component of the overall WWFP Adaptive CIP. The details for cost estimating methodology are summarized in Chapter 11.

| Table 5.30 CIP Terms and Definition Wastewater Facilities Plan One Water LA 2040 Plan | | |
|------------------------------------------------------------------------------------------------------|-----------------------------------|------------------------------------------------------------------------------------------------------------------------------------------------------------------------------------------------------------------------------------------------------------------------------------------------------------------------------------------------------------------------------|
| Group | Term | Definition |
| Category | Capital Project from WCIP | These projects were previously identified in the WCIP. These projects include new construction, expansion, or renovation that helps maintain or improve a City facility or infrastructure that may be funded by the Capital Budget. |
| | R&R from WCIP | These are projects identified in the WCIP. These projects are needed for the continued operation of the facility in its present form. |
| | Climate Resilience ⁽¹⁾ | These are projects developed as part of the Plan and identified in Volume 6 Climate Risk and Resilience Assessment for Wastewater and Stormwater Infrastructure. These projects are needed to adapt to environmental conditions due to climate change |
| | Projected Capital Projects | These are projects not identified in the WCIP and are projected as part of the WWFP in collaboration from City staff. These projects include new construction, expansion, or renovation that helps maintain or improve a City facility or infrastructure that may be funded by the Capital Budget. Project costs were estimated using a methodology described in Chapter 11. |

| Table 5.30 CIP Terms and Definition Wastewater Facilities Plan One Water LA 2040 Plan | | |
|------------------------------------------------------------------------------------------------------|------------------------|----------------------------------------------------------------------------------------------------------------------------------------------------------------------------------------------------------------------------------------------------------------------------------------|
| | Projected R&R Projects | These are projects not identified in the WCIP and are projected as part of the WWFP in collaboration with City staff. These projects may be needed for the continued operation of the facility in its present form. These projects were estimated using the methodology in Chapter 11. |
| Phase ⁽²⁾ | Near-Term | Projects that are planned to be constructed between 2018 to 2020 |
| | Mid-Term | Projects that are planned to be constructed between 2021 and 2030 |
| | Long-Term | Projects that are planned to be constructed between 2031 and 2040 |
| Notes: | | |
| (1) Climate resilience projects were identified based on the analysis described in Volume 6. | | |
| (2) The phases were determined by LASAN and LADWP management for all projects included in the Plan. | | |

The following sections use the sources, methodologies, terms and definitions to present the In-Progress Projects, future integration opportunities and Estimated and Projected CIP for the DCTWRP Adaptive CIP.

5.5.1 DCTWRP In-Progress Projects

Table 5.31 summarizes the In-Progress Project for DCTWRP, estimated capital costs, projected construction completion, and resulting phase. Additional details of the In-Progress Project were previously summarized in Section 5.2.

| Table 5.31 Summary of DCTWRP In-Progress Project Estimated Costs Wastewater Facilities Plan One Water LA 2040 Plan | | | |
|-------------------------------------------------------------------------------------------------------------------------------------------------------------------------------------------------------------------------------------------------------------|------------------------------------------------------------------|--------------------------|--------------|
| In-Progress Projects | Estimated Capital Cost Estimate (\$2017) Millions | Year Complete | Phase |
| Groundwater Replenishment Project with Advanced Water Purification Facility (AWPF) at DCTWRP (up to 30,000 AFY in San Fernando Basin) ⁽¹⁾ | \$370 | 2019-2020 | Near/Mid |
| Total | \$370 | | |
| Note: | | | |
| (1) Per Los Angeles Groundwater Replenishment Project EIR (May 2016), GWR AWPF will yield a total of up to 35,000 AFY of purified water, of which 5,000 AFY will be used for NPR uses and up to 30,000 AFY will be used for groundwater replenishment uses. | | | |
| (2) Phasing will be split into near term and mid-term. | | | |

5.5.2 DCTWRP Concept Options

The concept options and priority identification for DCTWRP are summarized in Section 5.3. Concept Option #15 (DCTWRP to LAAFP) was identified as the Priority A. This concept option may also require the implementation of Concept Option #22 (East West Valley Interceptor Sewer). Recognizing that implementation of these concept options include both changes to DCTWRP and changes outside the plant, only the associated plant costs are included in the DCTWRP Adaptive CIP and the Wastewater Facilities Adaptive CIP. The plant-related estimated cost for Concept Option #15 (DCTWRP to LAAFP) and Concept Option #22 (East-West Valley Interceptor Sewer) in 2017 dollars is \$220 million and \$85 million, respectively.

5.5.3 DCTWRP Estimated and Projected CIP

The Estimated and Projected CIP is based on the WCIP, plus the climate risk analysis. In areas lacking any estimates of cost, a set of assumptions are used to develop projected costs for annual capital and replacement and rehabilitation projects. Details of these assumptions are summarized in Chapter 11. The Estimated and Projected CIPs for DCTWRP are provided in Table 5.32 and Figure 5.12. The details of the summary table can be found in Appendix H.

| Table 5.32 DCTWRP Estimated and Projected CIP Wastewater Facilities Plan One Water LA 2040 Plan | | | |
|--------------------------------------------------------------------------------------------------------|-----------------------------|--------------------------------|--------------------------------|
| | Category | Total (\$2017) Millions | Total (\$2017) Millions |
| Near-Term | Capital Project from WCIP | \$124 | \$146 |
| | R&R from WCIP | \$10 | |
| | Climate Resiliency Projects | \$12 | |
| | Projected Capital Projects | - | |
| | Projected R&R Projects | - | |
| Mid-Term | Capital Project from WCIP | \$21 | \$121 |
| | R&R from WCIP | - | |
| | Climate Resiliency Projects | - | |
| | Projected Capital Projects | - | |
| | Projected R&R Projects | \$100 | |
| Long-Term | Capital Project from WCIP | \$10 | \$350 |
| | R&R from WCIP | - | |
| | Climate Resiliency Projects | - | |
| | Projected Capital Projects | \$240 | |
| | Projected R&R Projects | \$100 | |
| | | Total | \$617 |

Table 5.32 shows that the majority of the Estimated and Projected CIP costs are anticipated to occur in the long-term phase. The near-term phase uses the projects identified in the WCIP, whereas a combination of projections and estimates were used for the mid and long-term phases. These projections are to account for future, but undefined costs that may occur at DCTWRP. The same information is shown graphically on Figure 5.12.

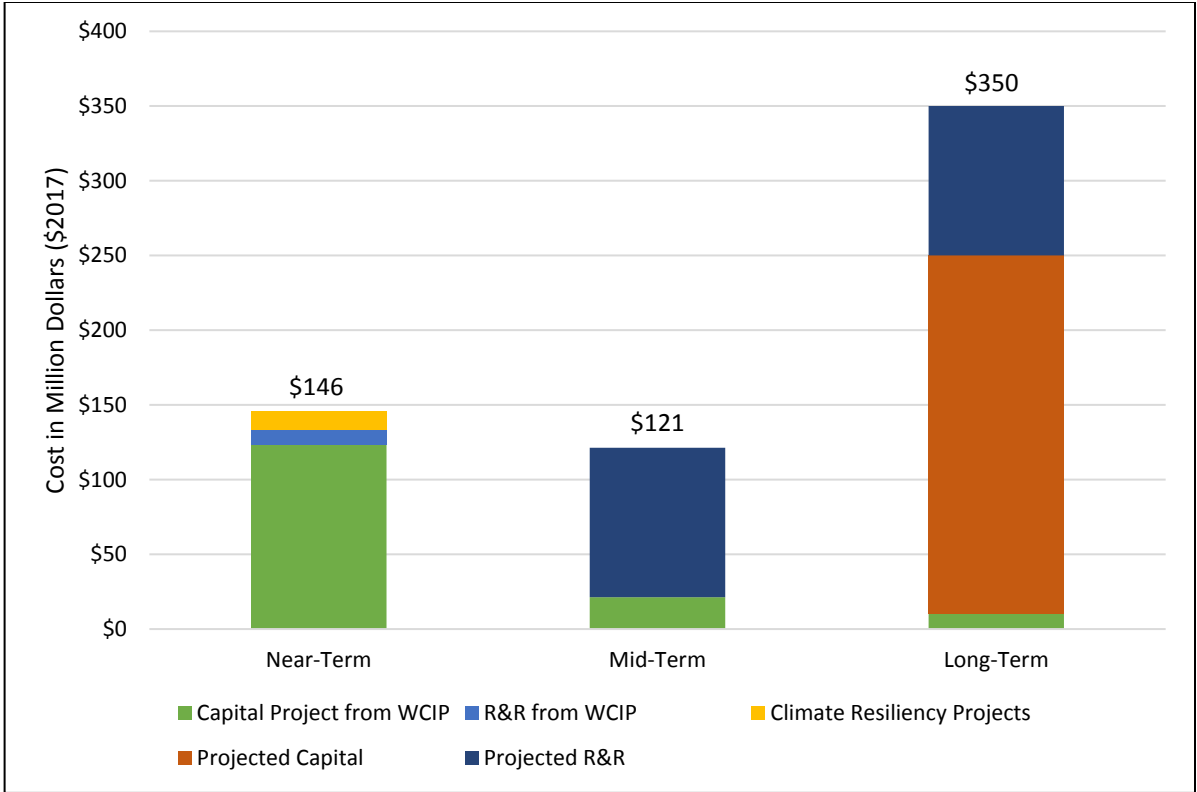

Figure 5.12 Summary of DCTWRP Estimated and Projected CIP Costs

The CIP for DCTWRP earmarks roughly the same amount in the near-term and mid-term. The near-term consists of mostly capital projects identified in the WCIP, in addition to replacement and rehabilitation projects identified in the WCIP and climate resiliency projects. The mid-term consists of capital projects from the WCIP and projected replacement and rehabilitation values. The long-term phase is primarily projected capital projects and replacement and rehabilitation projects to account for costs that have not yet been identified. The Estimated and Projected CIP costs summarized in Table 5.32 has a total cost of \$617 million which translates to an average cost of approximately \$48.7 million per year from 2018 to 2020, \$12.1 million per year from 2021 to 2030, and \$35 million per year from 2031 to 2040. The high value in the near-term is representative of a large capital improvement project (Ozone Demonstration Project) at DCTWRP. As the City defines more projects for DCTWRP, this Estimated and Projected CIP summary should be updated to reflect accurate numbers for the mid- and long-terms.

Figure 5.13 presents the same Estimated and Projected CIP information as Table 5.32 depicting the total value by percent allocated to each category. The Projected Capital project category is the largest due to the values that were calculated for future unanticipated costs.

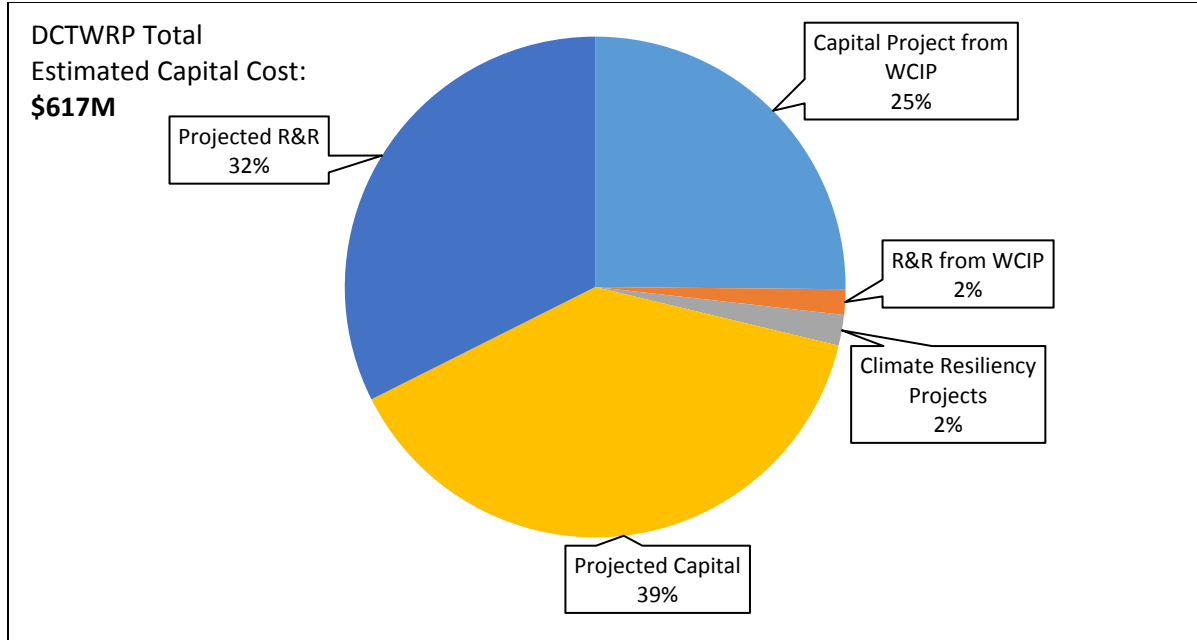

Figure 5.13 DCTWRP Estimated and Projected CIP Costs by Category in 2017 Dollars

5.5.4 DCTWRP Adaptive CIP Summary

The combination of the In-Progress Projects, future integration opportunities, and Estimated and Projected CIP serve as the basis for the DCTWRP portion of the WWFP Adaptive CIP. These three sources of projects are summarize in 2017 dollars in Table 5.33.

| Table 5.33 DCTWRP Adaptive CIP Summary 2017 (\$M) | | | | |
|----------------------------------------------------------|------------------------------------|-----------------------------------|------------------------------------|--------------------|
| Wastewater Facilities Plan | | | | |
| One Water LA 2040 Plan | | | | |
| Category | Near-term (2018-2020) (\$M) | Mid-term (2021-2030) (\$M) | Long-term (2031-2040) (\$M) | Total (\$M) |
| In-Progress Projects | | | | |
| Groundwater Replenishment Project with AWPf at DCTWRP | \$185 | \$185 | \$0 | \$370 |
| Subtotal | \$185 | \$185 | \$0 | \$370 |
| Projected CIP Projects | | | | |
| Capital Project from WCIP | \$124 | \$21 | \$10 | \$155 |
| R&R from WCIP | \$10 | - | - | \$10 |
| Climate Resiliency Projects | \$12 | - | - | \$12 |
| Projected CIP Projects | - | - | \$240 | \$240 |
| Projected R&R Projects | - | \$100 | \$100 | \$200 |
| Subtotal | \$146 | \$121 | \$350 | \$617 |

| Table 5.33 DCTWRP Adaptive CIP Summary 2017 (\$M) Wastewater Facilities Plan One Water LA 2040 Plan | | | | |
|--------------------------------------------------------------------------------------------------------------------|--------------------------------------------|-------------------------------------------|--------------------------------------------|------------------------|
| Category | Near-term (2018-2020) (\$M) | Mid-term (2021-2030) (\$M) | Long-term (2031-2040) (\$M) | Total (\$M) |
| Future Integration Opportunities (WWFP Cost Element) | | | | |
| Concept Option #15(DCTWRP to LA Aqueduct Filtration Plant) | \$0 | \$0 | \$220 | \$220 |
| Concept Option #22 (East-West Valley Interceptor Sewer) | \$85 | \$0 | \$0 | \$85 |
| Subtotal | \$85 | \$0 | \$220 | \$305 |
| Total | \$416 | \$306 | \$570 | \$1,292 |

The overall CIP in 2017 dollars for DCTWRP is \$1,292 million, between 2018 and 2040, which equates to roughly \$56 million per year. The majority of the expenditures are anticipated to fall within the long-term phase. This is driven by the inclusion of the long-term concept option as well as the projected CIP values that were calculated. This same information is presented graphically on Figure 5.14.

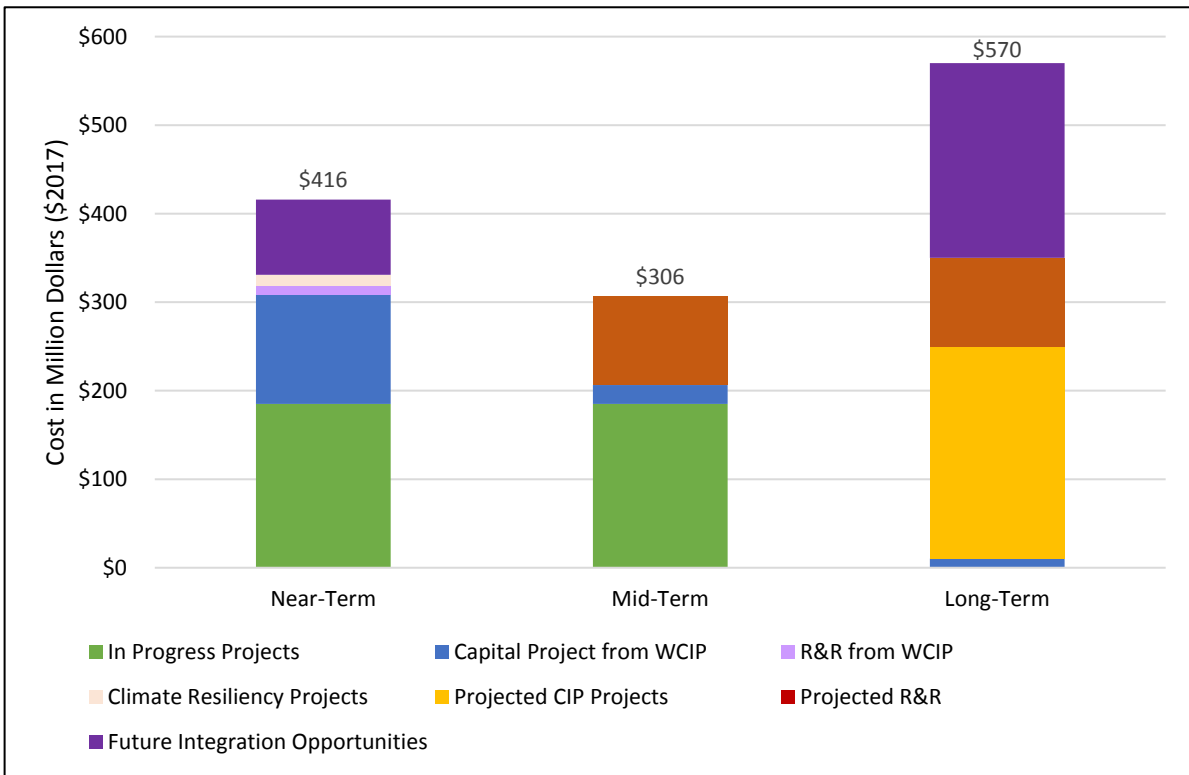

Figure 5.14 DCTWRP Adaptive CIP Summary by Phase

The DCTWRP Adaptive CIP costs summarized in Table 5.33 total \$1,292 million which translates to an average cost of approximately \$139 million per year from 2018 to 2020, \$30.6 million per year from 2021 to 2030, and \$57 million per year from 2031 to 2040.

Figure 5.15 presents the same information but depicts the total value by percent allocated to each category. The future integration opportunities is the largest of the three categories due to the inclusion of the two concept options, Concept Option #15 (DCTWRP to LAAFP) and Concept Option #22 (East-West Valley Interceptor Sewer).

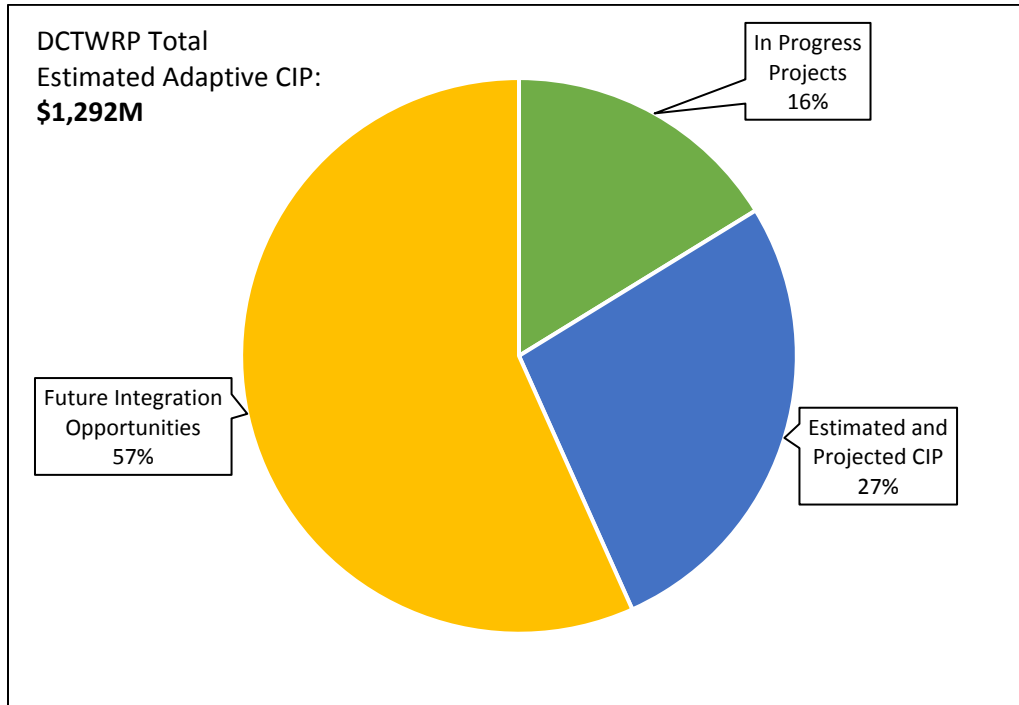

Figure 5.15 DCTWRP Adaptive CIP Summary by Category

The costs in the DCTWRP Adaptive CIP are presented in 2017 dollars but future costs should be adjusted to account for the time value of money. Section 5.5.5 discusses the methodology used to account for these future values.

5.5.5 DCTWRP Adaptive CIP Net Present Worth Summary

The values for each of the projects were developed in 2017 dollars. Recognizing that the City will not implement all projects immediately, the projects have been divided into phases. The costs for the projects that are scheduled to be implemented in the near, mid and long-term were adjusted to account for inflation and escalated at a rate of 3 percent per year. To allow a comparison of costs between phases, the escalated costs were brought back to a present value using a discount rate of 2 percent per year. Discounting the escalated costs yields a net present value and reflects the future values in 2017 dollars. Figure 5.16 summarizes the total CIP for DCTWRP, with the values for future projects presented as a net present worth.

The net present worth of the DCTWRP Adaptive CIP for all three phases totals \$1,440 million. For the 2040 planning horizon, this total value equates to \$62 million on an annual basis. Figure 5-16 shows how the time value of money impacts each of the phases of the CIP.

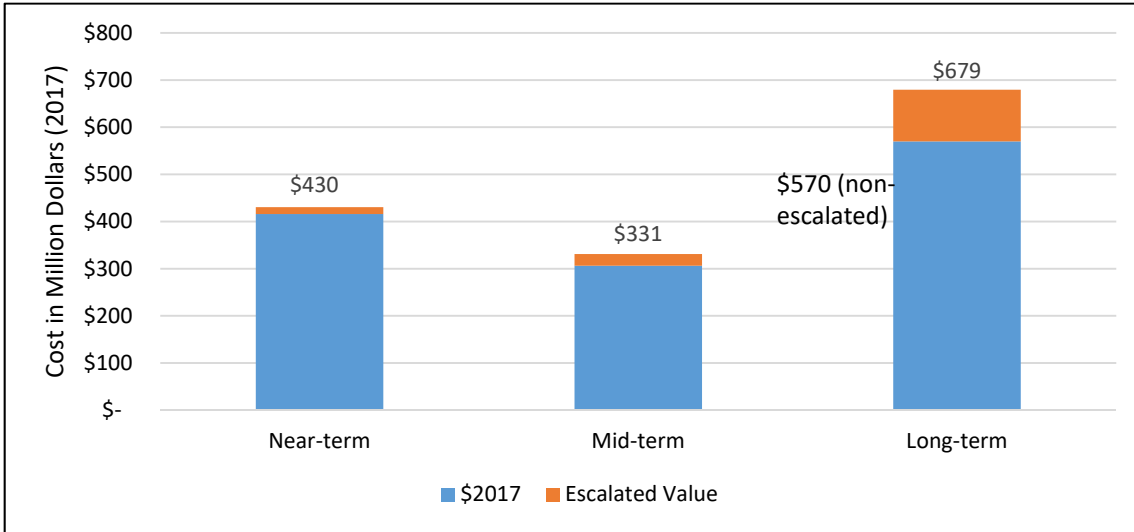

Figure 5-16 Present Worth Comparison: Escalated versus Non Escalated CIP

The long-term phase has the greatest impact on the CIP, due to the large amount of money that needs to be accounted for in today's dollars.

LOS ANGELES-GLENDALE WATER RECLAMATION PLANT

In operation since 1976, the LAGWRP was the first water reclamation plant to operate in Los Angeles and is co-owned by the cities of Los Angeles and Glendale and operated and maintained by LASAN. It began operation in 1986 as a full tertiary treatment facility with a total treatment capacity of 20 mgd. In 1991, the secondary treatment process was retrofitted with a fine bubble diffuser system to reduce operating costs. In 2006, the plant was upgraded to include NdN. LAGWRP is located at the southeast junction of the Los Angeles River Flood Control Channel and Colorado Boulevard between Griffith Park and the City of Glendale. The aerial map of this plant is shown on Figure 6.1.

The Cities of Glendale and Burbank both have contractual agreements with the City of Los Angeles for wastewater conveyance and treatment services. A portion of the City of Glendale, which owns 50 percent of the plant, is outside the LAGWRP tributary area. However, wastewater flows are not strictly limited to the contracting cities; flows from the San Fernando Valley theoretically can be directed to the NOS (described further below), and thus could be added to the plant's influent. The influent is approximately 80 percent municipal sewage (residential and commercial) and 20 percent industrial sewage. LAGWRP's service area is approximately 32.9 square miles and is shown on Figure 6.2.

The NOS helps provide hydraulic relief for the downstream interceptor conveyance facilities and HWRP. It is supplemented by two other wastewater treatment facilities in the Los Angeles-Glendale Service Area; the BWRP, and the LAZTF. LAGWRP typically operates near capacity and treats constant flows since it can bypass flow to HWRP if necessary.

This chapter describes the Existing Treatment Process Description, In-Progress Projects, Future System Needs Evaluation, Climate Risk and Resilience Analysis and Adaptive Capital Improvement Plan for LAGWRP.

6.1 EXISTING TREATMENT PROCESS DESCRIPTION

This section outlines existing systems at LAGWRP, documents plant upgrades, and is organized as follows:

- General plant overview
- Current flows and loadings
- Process descriptions
- Identified current needs

Understanding existing facilities is critical to the assessment of future potential projects to improve performance and enhance water reuse.



Figure 6.1
LAGWRP Aerial Overview
One Water LA 2040 Plan

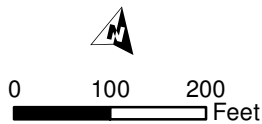

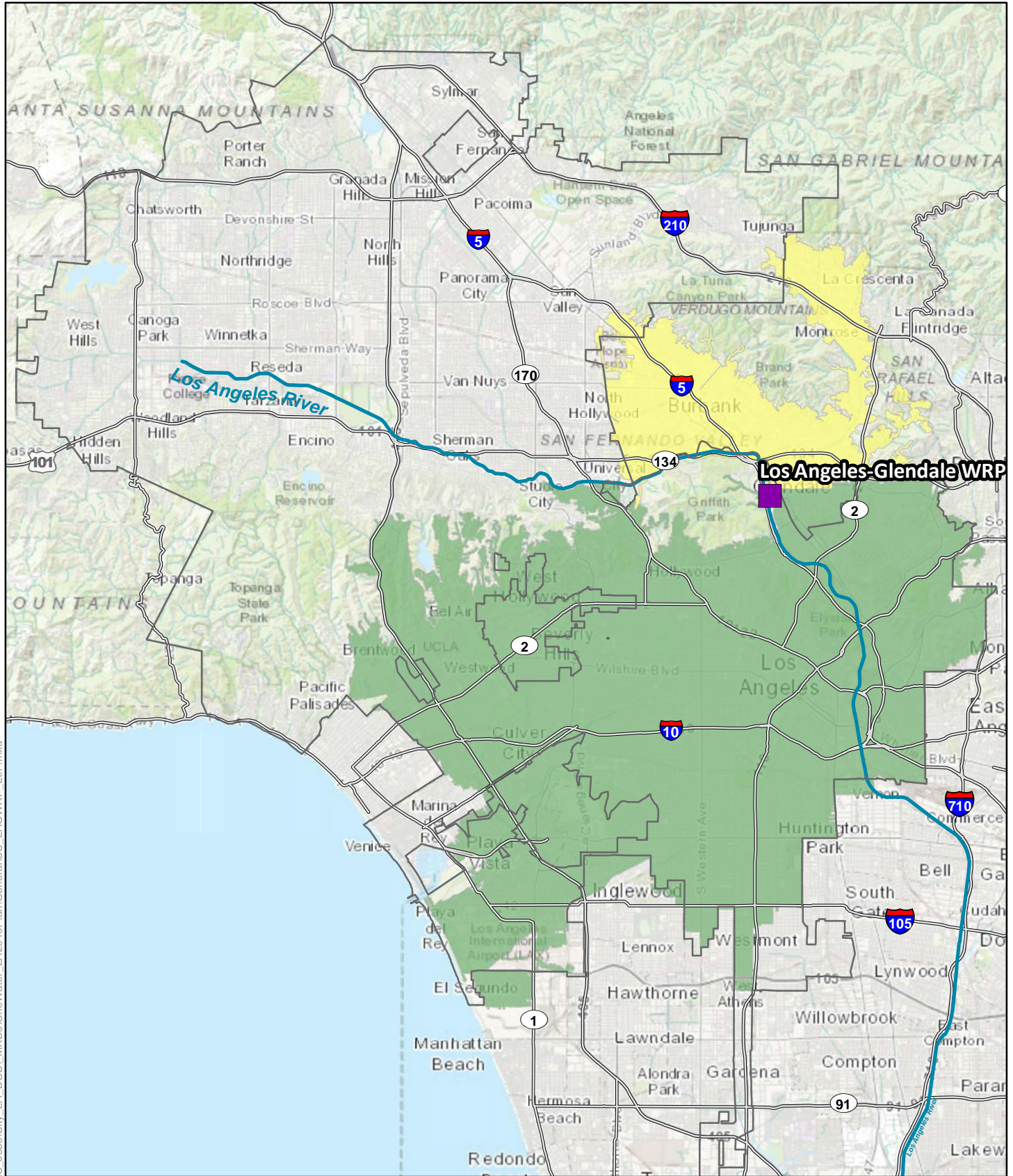

Los Angeles-Glendale WRP

- Existing Water Reclamation Plant (WRP)
- HWRP Metro Sewershed
- LAGWRP Sewershed

Figure 6.2
LAGWRP Location and Sewershed
 One Water LA 2040 Plan

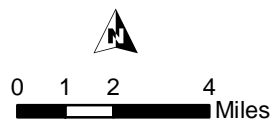

6.1.1 Treatment Process Overview

LAGWRP currently operates as a secondary treatment facility with full tertiary filtration capabilities. Its effluent is either reclaimed or discharged to the LA River. The plant's process flow diagram is shown on Figure 6.3. Reading left to right, treatment include preliminary treatment (bar screens) and primary clarification followed by a multi-zone air activated sludge process operated to achieve secondary treatment as well as reduce nitrogen constituents. Tertiary filtration follows, along with disinfection prior to discharge/water reuse. Skimming and solids generated are returned to the sewer for treatment at HWRP.

LAGWRP does not currently utilize its full treatment potential, due to constraints in the Ndn process. Also, diurnal flow fluctuations cause loading spikes in the system that will require additional equalization capacity if the plant is to process flows up to its rated capacity.

The following sections provide an overview of influent and effluent flow characteristics as well as documenting the existing processes and operating conditions at LAGWRP for:

- Preliminary Treatment
- Primary Treatment
- Secondary Treatment
- Tertiary Treatment
- Disinfection

Ancillary facilities are also reviewed. For individual processes and systems information is provided in Section 6.1.4 through Section 6.1.12.

6.1.2 Influent Flow and Characteristics

The design criteria for the influent BOD and TSS concentrations are 200 mg/L and 250 mg/L, respectively. Table 6.1 shows wastewater quality data for the fiscal year July 2014 to June 2015. This data shows that BOD and TSS concentrations far exceed the plant's design criteria. A significant amount of the BOD is settleable and removed in the primary clarifiers. The high concentrations of TSS can be attributed to underflow from the NOS, however it does not significantly affect the processes at the plant.

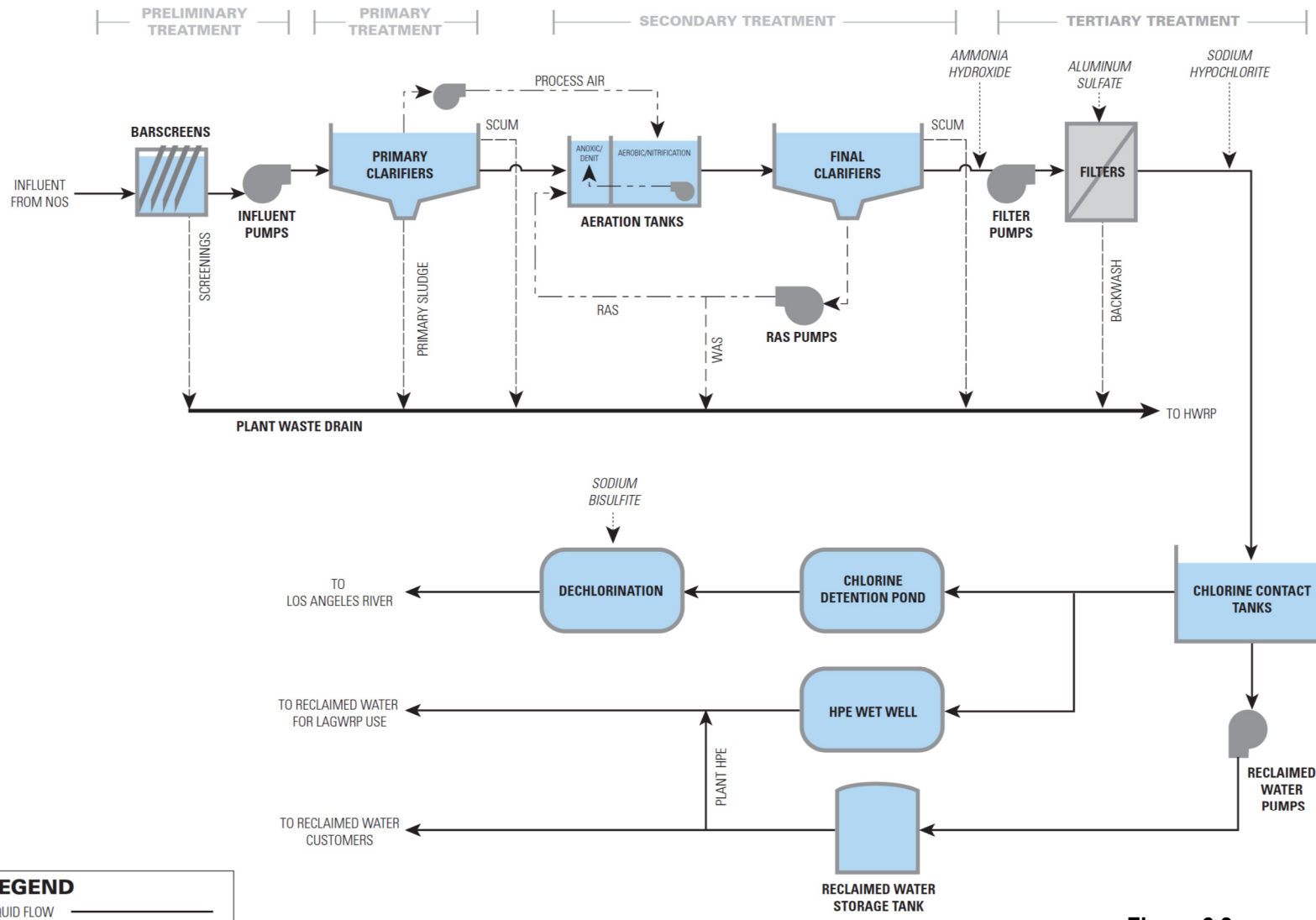

LEGEND

| | |
|-------------|-----------|
| LIQUID FLOW | ————— |
| WASTE FLOW | - - - - - |
| CHEMICAL | |
| RECYCLE | - - - - - |

Figure 6.3
LAGWRP Process Flow Diagram
 One Water LA 2040 Plan

| Table 6.1 LAGWRP Influent Flow and Characteristics Wastewater Facilities Plan One Water LA 2040 Plan | | |
|---------------------------------------------------------------------------------------------------------------------|---------------------|--------------|
| Parameter | Design Value | Value |
| Average Daily Flow | 20 mgd | 17 mgd |
| Peak Daily Flow | - | 23.6 mgd |
| Average BOD | | |
| Concentration | 200 mg/L | 819 mg/L |
| Mass Loading | 17 tpd | 60 tpd |
| Average TSS | | |
| Concentration | 250 mg/L | 596 mg/L |
| Mass Loading | 21 tpd | 43 tpd |
| Maximum Daily BOD | - | 1,340 mg/L |
| Maximum Daily TSS | - | 2,440 mg/L |
| <i>Source: Monthly Performance Reports July 2014 to June 2015</i> | | |

6.1.3 Effluent Flow and Characteristics

The plant effluent is compliant with Title 22 standards for disinfected tertiary recycled water and meets constituents in LAGWRP's NPDES permit which are summarized in Table 6.2. Effluent is pumped to either the recycled water distribution system (i.e., landscape irrigation to Griffith Park and the Los Angeles Greenbelt Project), or flows by gravity to the Los Angeles River. All solids removed from the treatment process are returned untreated to the NOS for conveyance to HWRP for downstream treatment.

6.1.4 Process Descriptions

In the sections that follow, descriptions are provided of LAGWRP's liquid treatment processes and ancillary facilities. Provided are:

- Component descriptions and design criteria
- Summary of operations
- Current performance metrics

This information provides the foundational basis for the development of future plant improvements.

| Table 6.2 LAGWRP NPDES Effluent Limitations Wastewater Facilities Plan One Water LA 2040 Plan | | | | |
|--------------------------------------------------------------------------------------------------------------|----------------|------------------------|-----------------------|----------------------|
| Constituent | Units | Monthly Average | Weekly Average | Maximum Daily |
| BOD ₅ | mg/L | 20 | 30 | 45 |
| | lbs/day | 3,340 | 5,000 | 7,510 |
| TSS | mg/L | 15 | 40 | 45 |
| | lbs/day | 2,500 | 6,680 | 7,500 |
| pH | standard units | | 6.5 – 8.5 | |
| Fluoride | mg/L | 2.0 | -- | -- |
| Oil and Grease | mg/L | 10 | -- | 15 |
| | lbs/day | 1,670 | -- | 2,500 |
| Settleable Solids | ml/L | 0.1 | -- | 0.3 |
| Total Residual Chlorine | mg/L | -- | -- | 0.1 |
| | lbs/day | -- | -- | 17 |
| Total Dissolved Solids | mg/L | 950 | -- | -- |
| | lbs/day | 158,600 | -- | -- |
| Sulfate | mg/L | 300 | -- | -- |
| | lbs/day | 50,080 | -- | -- |
| Chloride | mg/L | 190 | -- | -- |
| | lbs/day | 31,710 | -- | -- |
| MBAS | mg/L | 0.5 | -- | -- |
| | lbs/day | 83 | -- | -- |
| Ammonia Nitrogen | mg/L | 3.7 | -- | 5.7-7.4 |
| | lbs/day | 617 | -- | 951 – 1,234 |
| Nitrate + Nitrite (as N) | mg/L | 7.2 | -- | -- |
| Nitrate (as N) | mg/L | 7.2 | -- | -- |
| Nitrite (as N) | mg/L | 0.9 | -- | -- |
| Temperature | °F | | 86 | |
| Turbidity | NTU | 2 | -- | -- |
| <i>Source: NPDES Permit No. CA0053953, Order No. R4-2017-0063</i> | | | | |

6.1.5 Preliminary Treatment

Preliminary treatment consists of screening, influent pumping, and grit removal. These processes help remove materials that can clog and damage subsequent treatment equipment, cause excessive wear, or reduce treatment efficiency. Preliminary treatment also provides flow control by the influent pumps, which operate off a preset flow set point or automated wet well level measurements taken in the inlet channel and bar screen chamber. Influent bypass control is provided by an inlet sluice gate. The preliminary treatment process was designed to handle influent flow greater than the 20 mgd capacity of the plant. The various components are described below and summarized in Table 6.3.

The preliminary treatment process at LAGWRP includes:

- Screening,
- Influent Pumping, and
- Grit Removal

6.1.5.1 Screening

The LAGWRP Headworks Building includes two mechanically raked climber bar screens (one duty, one standby) that each have a capacity of 30 mgd. The bar screens remove large materials from the influent while allowing the liquid to flow through. These materials, such as rags or twigs, could damage equipment further along in the treatment process.

6.1.5.2 Influent Pumping

Wastewater is conveyed from the bar screens to the influent pump station, which consists of three variable-speed centrifugal, non-clog pumps, each rated at 200 hp. Each pump can supply up to 25 mgd at 26 feet total dynamic head (TDH). One variable-speed pump is required for normal operation, while the other pumps serve as standby units.

6.1.5.3 Grit Removal

LAGWRP has a small sludge and grit pumping system, approximately 300 gpm, which is installed at the influent pump wet wells. The grit system removes fine materials, such as sand or coffee grounds, that were not removed by the bar screens. These materials are essentially non-biodegradable over the course of the treatment and may form deposits in plant pipelines and cause abrasion in mechanical equipment further in the treatment process.

| Table 6.3 LAGWRP Preliminary Treatment Design Criteria Wastewater Facilities Plan One Water LA 2040 Plan | |
|------------------------------------------------------------------------------------------------------------------------------------------------------------|--------------------------------------|
| Unit | Value |
| Bar Screens | |
| Type | Fairfield Mechanically Raked Climber |
| Number | 2 (1 duty, 1 standby) |
| Capacity, each | 30 mgd |
| Influent Pumps | |
| Type | Worthington centrifugal, non-clog |
| Number | 3 (1 duty, 2 standby) |
| Capacity, each | 25 mgd |
| Grit Pumps | |
| Type | Wemco |
| Number | 1 |
| Capacity | 300 gpm |
| Flowmeters | |
| Type | Krohne, Magnetic |
| Number | 1 |
| Capacity, each | 40 mgd |
| <i>Sources: City of Los Angeles Integrated Resource Plan, 2006; City of Los Angeles Recycled Water Master Planning Long-Term Concepts Report: Volume 2</i> | |

6.1.5.4 Operation

Raw wastewater enters LAGWRP from the NOS by a concrete diversion structure. Influent flows are conveyed to mechanically raked climber-type bar screens for coarse debris and rag removal. There are two bar screens; one bar screen is required for normal operation while the other serves as a standby unit. The screened influent flows by gravity to the influent pump station while the screenings are returned to the NOS for downstream handling at HWRP. The current mode of operation for the bar screens is the timer mode (the rake makes one complete cycle and then waits a set time before making another cycle).

The pumps in the influent pump station discharge to a 24-inch steel pipe, which discharges the total influent flow to a 51-inch diameter steel header. The flow is then conveyed to the primary clarifiers. The influent flow is measured using a 36-inch magnetic flowmeter located in the 51-inch header.

The system pumps grit from the influent pump wetwell hoppers back to the NOS through the bar screen sluice trough.

6.1.5.5 Current Performance

According to recent data and meetings with plant staff, the preliminary treatment system is performing well. A standby bar screen will be added to improve operational flexibility as part of the upcoming project, CIP 4172 – Headworks Improvements.

6.1.6 Primary Treatment

Primary treatment allows time for settleable organic and inorganic materials that enter the plant to settle and be removed. Lighter solids (i.e. floatables, grease, etc.) float to the surface and are removed by skimming. The remaining wastewater is conveyed to the aeration tanks for secondary treatment. Primary treatment significantly reduces the BOD and TSS loadings to the secondary treatment facilities. The primary treatment process at LAGWRP includes:

- Primary Clarifiers
- Raw sludge return to sewer
- Scum return to sewer

The influent flow is distributed evenly to eight covered primary clarifiers for separation of settleable material, floatable solids, and grease from the influent wastewater. The tanks are covered to reduce odors. Table 6.4 provides a summary of the primary treatment facilities.

| Table 6.4 LAGWRP Primary Treatment Design Criteria Wastewater Facilities Plan One Water LA 2040 Plan | |
|---------------------------------------------------------------------------------------------------------------------|------------------------|
| Unit | Value |
| Primary Clarifiers | |
| Number | 8 (7 duty, 1 off-line) |
| Area | 140 ft x 20 ft |
| Water Depth | 10.6 ft |
| Capacity, each | 2.6 mgd |
| Capacity, total | 20.8 mgd |
| Surface Loading Rate | 1,040 gpd/sq ft |
| Detention Time | 1.9 hours |
| <i>Source: City of Los Angeles Integrated Resource Plan, 2006; Discussions with City staff.</i> | |

6.1.6.1 Operation

The primary influent header conveys the screened wastewater to an influent channel located at the inlet end of the covered primary clarifiers. Flow to the primary clarifiers is controlled by manual slide gates located at the inlet of each tank. Primary effluent leaves the primary clarifiers by means of V-notch weirs with launders. The launders discharge into a common channel that feeds the aeration tanks. Scum is collected in scum troughs by means of helical skimmers. The scum and floating materials flow by gravity down the scum trough to the NOS via the plant waste drain.

Primary sludge is collected by conventional chain-and-flight assemblies. The flights transport the settled sludge to a sludge hopper located at the influent end of each primary clarifier and transport the floating materials to a scum trough located just upstream of the effluent launders. Primary sludge is withdrawn from the sludge hoppers by opening the valves on each hopper (two hoppers per tank) and allowing the sludge to flow into the primary withdrawal line. The valves are operated automatically and use a timer to sequentially open the valves from basin to basin. The primary sludge flows by gravity to the NOS via plant waste drain.

6.1.6.2 Current Performance

At the average design flow (20 mgd), the detention time is 1.9 hours, with a surface overflow rate of 1,040 gpd/sq ft. For the fiscal year July 2014 to June 2015, the average primary effluent BOD concentration was 217 mg/L and the average primary effluent suspended solids concentration was 90 mg/L. Table 6.5 summarizes typical operational values for primary sedimentation, along with typical removal efficiencies of BOD, TSS and settleable solids.

| Table 6.5 LAGWRP Primary Treatment Performance Wastewater Facilities Plan One Water LA 2040 Plan | |
|-----------------------------------------------------------------------------------------------------------------|----------------------------|
| Description | Value⁽¹⁾ |
| Average Primary Influent Flow | 17.46 mgd |
| Average Sludge Flow | 0.38 mgd |
| Average Surface Overflow Rate (SOR) | 970-1,114 gpd/sq ft |
| Peak SOR | 1,020-1,367 gpd/sq ft |
| Average BOD ₅ Removal Efficiency | 72% |
| Effluent Concentration | 217 mg/L |
| Average TSS Removal Efficiency | 84% |
| Effluent Concentration | 90 mg/L |
| Average Settleable Solids Removal Efficiency | 98.3% |
| <i>Source: Monthly Performance Reports July 2014 to June 2015</i> | |
| Note: | |
| (1) Values provided for fiscal year July 2014 to July 2015 | |

The primary processes currently lack equalization. This issue is being addressed in CIP 4176 which adds equalization to the plant.

6.1.7 Secondary Treatment

The purpose of secondary treatment is to remove soluble BOD that is not removed by primary treatment and provide further removal of suspended solids. The secondary treatment process at LAGWRP includes:

- Nitrification/Denitrification Aeration Tanks
- Process Air System
- Secondary Clarifiers
- Return Activated Sludge Pump System
- Waste Activated Sludge System

The design basis, operations, and current performance of each of these are provided in the subsections that follow.

6.1.7.1 Nitrification/Denitrification Aeration Tanks

LAGWRP's secondary treatment process provides reductions in BOD and nitrogen. Nitrogen removal has two steps, nitrification and denitrification. In nitrification, organic-N compounds and $\text{NH}_3\text{-N}$ are converted to nitrite ($\text{NO}_2\text{-N}$) and then to nitrate ($\text{NO}_3\text{-N}$). In denitrification, the nitrate is converted to nitrogen gas (N_2), which is released to the atmosphere. This process requires an anoxic (absent of oxygen) environment and an organic carbon source.

In 2006, LAGWRP modified the six existing aeration tanks into NdN aeration tanks, each tank 240 feet long and 32 feet wide. Table 6.6 summarizes the process design criteria for the aeration tanks along with descriptions of the mixers and pumps. LAGWRP utilizes the MLE NdN aeration process, which includes six zones separated by wooden baffles, as summarized in Table 6.7.

| Table 6.6 LAGWRP NdN Treatment Design Criteria Wastewater Facilities Plan One Water LA 2040 Plan | |
|-----------------------------------------------------------------------------------------------------------------|-----------------------|
| Unit | Value |
| Aeration Tanks | |
| Number | 6 (5 duty, 1 offline) |
| Total Area | 240 ft x 211.5 ft |
| Water Depth | 16 ft |
| Internal Recycle Ratio | 4:1 |
| RAS Ratio | 1:1.0-1.5 |
| Total Detention Time | 1.6 hr |
| Mixers | |
| Type | US Filter |
| Number | 18 |
| Power, each | 7.5 hp |
| Internal Recycle Pump | |
| Type | Landia |
| Number | 6 |
| Capacity, each | 11,200 gpm |
| Head, each | 2 ft |
| Max Power, each | 20 hp |
| <i>Source: City of Los Angeles Integrated Resource Plan, 2006; Discussions with City staff.</i> | |

| Table 6.7 LAGWRP NdN Zone Description Wastewater Facilities Plan One Water LA 2040 Plan | | | |
|--------------------------------------------------------------------------------------------------------|--------------------|-------------------|-----------------------|
| Zone | Description | Length, ft | Size, % volume |
| Zone #1 | Mixing | 12 | 5 |
| Zone #2 | Anaerobic Selector | 24 | 10 |
| Zone #3 | Bio-P | 24 | 10 |
| Zone #4 | Aerobic | 24 | 10 |
| Zone #5 | Aerobic | 52.75 | 22 |
| Zone #6 | Aerobic | 103.25 | 43 |
| <i>Source: City of Los Angeles Integrated Resource Plan, 2006; Discussions with City staff.</i> | | | |

6.1.7.2 Operation

Zone 1 is for anoxic mixing of the RAS with the primary effluent (PE). The PE/RAS mix then flows to Zone 2 where it is contacted with mixed liquor recycle flow which provides the nitrate from the nitrification zones (Zones 5 & 6) and the primary effluent provides the carbon source. The RAS has a return ratio of approximately 1.5:1 of the influent flow to the aeration tanks. The anoxic zones are equipped with mechanical mixers to prevent settlement of the solids. Zone 2 is configured to act as a selector zone to help control filamentous bacteria. Zone 3 is configured to act as a BIO-P zone to be used for biological phosphorous removal in the future by diverting recycled mixed liquor thereto. Zone 4 is configured to act as a "swing" zone to allow operation as an anoxic or aerobic zone as the process conditions dictate depending upon variations in influent characteristics. If additional time is required for denitrification, it can be operated as an anoxic zone, otherwise, it acts as the first of three aerobic zones which provide the necessary air for nitrification.

Zone 5 and 6 are the principal aeration zones providing the bulk of air for nitrification, supplemented by Zone 4 as noted above, if necessary. The ammonia from the primary effluent remains unchanged as it passes through the previous zones (unless Zone 4 is in aerobic mode). Under normal operating conditions ammonia is converted into nitrate in Zone 5. An additional baffle is provided within the aeration Zones 5 and 6 to accommodate the possibility that different dissolved oxygen (DO) concentrations may be required, e.g. high values for accelerated nitrification in Zone 5, and perhaps a reduction in DO in Zone 6 to enhance clarification of the secondary effluent. The RAS and internal recycle pumps transport this nitrate-rich wastewater to the anoxic zones for denitrification.

Cationic polymer and ammonia hydroxide (NH_4OH) are also added. Cationic polymer is added for foam control at an average dose of 0.3 percent. Ammonia hydroxide is added at the discharge of the secondary effluent for trihalomethane (THM) control at an average dose of 2 percent.

6.1.7.3 Current Performance

The NdN system was designed for a 400 percent internal recycle ratio and 100 percent to 150 percent RAS recycle ratio, but operates with a slightly higher recycle flow. Table 6.8 presents current performance data for the NdN system.

The NdN treatment process is performing well, except for the higher than design recycle ratio. An operational concern for plant staff is that during the winter, all of the aeration tanks must be running to achieve desire levels of treatment. As a result, it is only during summer months that a tank can be removed from service for routine maintenance such as cleaning of the diffusers.

| Table 6.8 LAGWRP NdN Treatment Performance Wastewater Facilities Plan One Water LA 2040 Plan | |
|-------------------------------------------------------------------------------------------------------------|--------------|
| Description | Value |
| Average Aeration Tank Influent Flow | 17.1 mgd |
| Average Detention Time | 2.21 hr |
| Average RAS Ratio | 118% |
| Average Recycle Ratio | 441% |
| Average BOD Removal Efficiency | 95% |
| Average TSS Removal Efficiency | 97% |
| Average NH ₃ -N Reduction | 99% |
| <i>Source: Monthly Performance Reports July 2014 to June 2015</i> | |

6.1.7.4 Process Air System

The process air system supplies air to the aeration tanks in the secondary treatment process. It is composed of blowers, compressors, and diffusers.

Process air is currently supplied by up to three, 1,500 hp centrifugal blowers, each capable of delivering up to 27,000 scfm of air. The process air system was designed for five aeration basins online for a total ADWF of 20 mgd. The blowers, housed in the Blower Building, provide air for the aeration basins which contain approximately 2,672 air diffusers each. Table 6.9 summarizes the process air system for LAGWRP.

| Table 6.9 LAGWRP Process Air System Design Criteria Wastewater Facilities Plan One Water LA 2040 Plan | |
|----------------------------------------------------------------------------------------------------------------------|---------------------------------------------------------------------------------------------------------------------------------|
| Unit | Value |
| Blowers | |
| Type | Turblex, Centrifugal |
| Number | 4 (1 duty, 2 standby) Note: One Roots Blower 17,000 scfm, 7.5 psig will be running during low flow scenarios and emergencies |
| Design Capacity, each | 27,000 scfm |
| Design Pressure, each | 9.0 psig |
| <i>Source: LAGWRP Record Drawings, LABOE Vault</i> | |

6.1.7.5 Operation

Foul air is pulled off the top of the primary clarifiers and enters the blowers through 2-stage process air filters. The air is then delivered through a 60-inch main air header that feeds air supply pipelines for each aeration tank where it travels through downcomer pipes feeding four grids of ceramic fine-bubble aeration disks in each tank.

The aeration process uses dissolved oxygen (DO) probes on each aerated grid to regulate the control valve on the air header feeding each tank. The probes send readings to the DCS which averages the values and compares it to the DO setpoint. If there is a significant difference between the reported and setpoint DO, the air control valves are sent a command to open or close to adjust the DO closer to the setpoint.

The process air compressors (PAC) are housed in the Blower Building as well and are controlled by a pressure set point, which is generated by the most open valve (MOV). MOV control looks at the position of the main air valves and selects the Most Open to determine the set point. For example, as the aeration demand increases, the main air valve positions increase and create a higher set point.

6.1.7.6 Current Performance

The recently installed blowers are running well. One of the older blower remains in service to be used in times of low flow or in case of a total power outage as it is still connected to the emergency generator. The older blower has a design capacity of 17,500 scfm, a design pressure of 7.5 psig and a motor power of 900 hp.

6.1.7.7 Secondary Clarifiers

Secondary clarifiers allow enough time and space for "aggregated" microorganisms to settle out so they can be recycled to the aeration basins or discharged out of the plant. Table 6.10 summarizes the secondary clarifiers for LAGWRP.

| Table 6.10 LAGWRP Secondary Clarifiers Design Criteria Wastewater Facilities Plan One Water LA 2040 Plan | |
|-------------------------------------------------------------------------------------------------------------------------|----------------|
| Unit | Value |
| Secondary Clarifiers | |
| Number | 10 |
| Area | 170 ft x 20 ft |
| Side Water Depth (SWD) | 9.6 ft |
| Surface Area per Clarifier | 3,400 sq ft |
| Detention Time (ADWF) | 1.5 hours |
| Surface Loading Rate (ADWF) | 490 gpd/sq ft |
| <i>Source: City of Los Angeles Integrated Resource Plan, 2006; Discussions with City staff.</i> | |

6.1.7.8 Operation

Treated wastewater flows from the NdN aeration tank into secondary clarifiers. There are 10 secondary clarifiers at LAGWRP. The majority of the settled microorganisms are recycled to the aeration tanks to maintain biological equilibrium. Excess organisms bypass this return step and are discharged back into the sewer system for final treatment at HWRP.

The secondary clarifiers are arranged with the sludge hoppers at the effluent end, beneath the effluent weirs. Conventional plastic flight-and-chain assemblies (plastic chain and sprockets with fiberglass flights) provide sludge collection. The flights transport the settled sludge to the sludge hoppers and transport the floating materials to slotted pipe skimmers located at the inlet end of the secondary clarifiers. The skimmers are operated manually every four hours by the operations staff. In 2007, baffles were installed in the secondary clarifiers to create more efficiency. This greater efficiency allows the plant to take one clarifier offline for maintenance as needed.

6.1.7.9 Current Performance

At the design criteria for an average flowrate of 20 mgd, with all units online, the detention time is 1.5 hours and the SOR is 490 gpd/sq ft. Table 6.11 summarizes performance of the secondary clarifiers from July 2014 to June 2015.

| Table 6.11 LAGWRP Secondary Clarifier Performance Wastewater Facilities Plan One Water LA 2040 Plan | |
|--------------------------------------------------------------------------------------------------------------------|-------------------|
| Description | Value |
| Average Surface Overflow Rate (SOR) | 451-513 gpd/sq ft |
| Average Surface Loading Rate | 24-28 lbs/d/sq ft |
| <i>Source: Monthly Performance Reports July 2014 to June 2015</i> | |

6.1.7.10 Return Activated Sludge and Waste Activated Sludge System

Once the majority of microorganisms have settled out in the secondary clarifiers, they are recycled back to the aeration tanks as RAS to treat incoming primary effluent. Excess microorganisms, or WAS, bypass this return step and are discharged back into the NOS. A summary of the RAS system of LAGWRP's secondary treatment process is presented in Table 6.12.

| Table 6.12 LAGWRP RAS System Design Criteria Wastewater Facilities Plan One Water LA 2040 Plan | |
|---------------------------------------------------------------------------------------------------------------------------------------------|-------------------------------|
| Unit | Value |
| RAS Pumps | |
| Type | Chicago Pumps, Variable-speed |
| Number | 5 (3 duty, 2 standby) |
| Capacity, each | 5,290 gpm |
| Head, each | 50 ft |
| Power, each | 100 hp |
| <i>Sources: LAGWRP Record Drawings, LABOE Vault; City of Los Angeles Recycled Water Master Planning Long-Term Concepts Report: Volume 2</i> | |

6.1.7.11 Operation

Each secondary clarifier contains two hoppers with sludge withdrawal piping manifolded to a common meter and control valve for each tank. The flow from each tank goes to a common channel, which leads to the RAS pump wet well. Three of the five, 100 hp pumps pump RAS back to the influent of the NdN aeration tanks. The current mode of operation utilizes one variable-speed RAS pump, with two variable-speed RAS pumps on standby. The desired flow of RAS is input as a set point in the process control system as a percentage of the influent flowrate to the LAGWRP. The total desired flow is then split evenly between all the in-service secondary clarifiers, and the control valve for each secondary clarifier is adjusted accordingly. The RAS pump is controlled by a level set point for the RAS wet well. The WAS flows as a sidestream off the RAS header. A motor-operated control valve and flowmeter is used to regulate the flow.

6.1.7.12 Current Performance

The RAS system is currently operating efficiently at capacity.

6.1.8 Tertiary Treatment

Recycled water use is governed by the Water Reclamation Criteria, which is detailed within Title 22 of the California Code of Regulations. LAGWRP currently treats flow to Title 22 tertiary treatment requirements. This level of treatment, or "tertiary treatment," consists of coagulant addition and rapid sand/dual media or cloth filtration. Filtration is used in tertiary treatment to remove residual suspended solids remaining after secondary treatment and is aided by coagulation.

The tertiary treatment process at LAGWRP includes:

- Pumping and Coagulation
- Filtration

6.1.8.1 Pumping and Coagulation

At LAGWRP, secondary effluent from the secondary clarifiers flows through channels to the filter pump wet well for the beginning of tertiary treatment. Pumping and coagulation is the first step in LAGWRP's tertiary treatment. A summary of the tertiary pumping and coagulation system is presented in Table 6.13.

| Table 6.13 LAGWRP Pumping and Coagulation Design Criteria Wastewater Facilities Plan One Water LA 2040 Plan | |
|------------------------------------------------------------------------------------------------------------------------------------------------------------|------------------------------|
| Unit | Value |
| Filter Feed Pumps | |
| Type | Sulzer Pumps, Variable-Speed |
| Number | 3 (2 duty, 1 standby) |
| Power, each | 150 hp |
| Head, each | 22 ft |
| Capacity, each | 15,000 gpm |
| Coagulation | |
| Chemical | Polymer |
| Volume of Storage Tank | 7,500 gallons |
| <i>Sources: City of Los Angeles Integrated Resource Plan, 2006; City of Los Angeles Recycled Water Master Planning Long-Term Concepts Report: Volume 2</i> | |

6.1.8.2 Operation

There are three (2 duty, 1 standby), 150 hp filter feed pumps, each capable of pumping up to 15,000 gpm. The wet well controls pump operation and sequencing to the filters. Coagulation is the addition of chemicals to destabilize colloidal suspensions to allow for the formation of a settleable floc. At LAGWRP, this is facilitated by the cationic polymer, which is pumped into the filter pump discharge header. The polymer is also used for foam control.

6.1.8.3 Current Performance

The pumping and coagulation system is currently operating efficiently with available capacity remaining. There are currently no planned upgrades to the pumping and coagulation system. However, since alum is no longer used for coagulation, the old alum facility will eventually be removed from the site. There are concern related to plant performance relating to the impact of polymer addition and the creation of NDMA. NDMA formation is triggered by various precursors in the wastewater as well as the addition of certain compounds which includes polymer and chlorine in the form of chloramines. This issue is being studied so it can be addressed properly in the future.

6.1.8.4 Filtration

Filtration is used in tertiary treatment to remove residual suspended solids remaining after secondary treatment. At LAGWRP tertiary filtration is accomplished with two types of filters: cloth media filters and deep-bed sand filters. The deep-bed sand filters are manufactured by Tetra and consist of a six feet depth of sand on an 18-inch gravel base. They are also used for nitrate reduction in addition to suspended solids removal. The cloth media filters are AquaDisk® filters that have been relocated from the DCTWRP and thus were not new at the time of installation. The cloth media is completely submerged in the filter tank. Wastewater passes through the media by gravity and the filtered water enters the internal portion of disk where it is discharged through a center shaft for disinfection. There are four cloth media filters and five deep-bed sand filters. A summary of the filtration process at LAGWRP and filtration design criteria is provided in Table 6.14.

| Table 6.14 LAGWRP Filtration Design Criteria Wastewater Facilities Plan One Water LA 2040 Plan | |
|------------------------------------------------------------------------------------------------------------------------------------------------------------|-----------------------|
| Unit | Value |
| Cloth Media Filters (Aqua-Aerobic Systems) | |
| Number | 4 |
| Type | AquaDisk® |
| Average Flow, each | 3 mgd |
| Maximum flow, each | 5.5 mgd |
| Backwash Pumps | |
| Type | Gorman-Rupp |
| Number | 8 (4 duty, 4 standby) |
| Capacity, each | 130 gpm |
| Head, each | 23 ft |
| Power, each | 2 hp |
| Deep Bed Rectangular Filters (Tetra) | |
| Number | 5 |
| Media | Sand |
| Media Depth | 6 ft |
| Support Layer | Gravel |
| Support Layer Depth | 1.5 ft |
| Area | 42 ft x 10 ft |
| Filtration Rate | 3.3 gpm/sq ft |
| <i>Sources: City of Los Angeles Integrated Resource Plan, 2006; City of Los Angeles Recycled Water Master Planning Long-Term Concepts Report: Volume 2</i> | |

6.1.8.5 Operation

Discharge from the final clarifiers is pumped into a 72-inch header, which provides flow to the filter units via three splitter boxes. Flow is pumped into the splitter boxes and then travels by gravity into each filter unit.

Backwash of the deep-bed sand filters is typically performed once per day and can be initiated automatically based on head loss through the filters or initiated manually. The current operational strategy calls for each filter backwash to be initiated manually by the operators once per shift. During backwash, influent flow to the filters is diverted to the other operating filters and a combination of filtered effluent and air from dedicated filter backwash blowers is used to fluidize the filter bed.

Solids accumulate on the outside of the cloth and are removed during backwash. Backwash is triggered by increased head loss due to deposited solids on the media. During backwash, a pump provides liquid suction to both sides of each disk and vacuum solids directly from the cloth. Some solids will settle to the bottom of the tank during normal operation. Small suction headers provide a means for collecting and discharging the settled solids. The solids collection process utilizes the backwash pump for suction. Backwash water is collected from both filters and returned by gravity to the NOS via the plant waste drain for final treatment at HWRP.

6.1.8.6 Current Performance

The filtration process operates with an average flow rate of 1.7 gpm/sq ft, an average effluent turbidity of 0.49 NTU and an average removal efficiency of 75 percent. The filters have an average backwash of 0.80 mgd.

6.1.9 Disinfection

Disinfection is necessary to meet the water reuse requirements dictated by Title 22 of the California Code of Regulations. At LAGWRP, sodium hypochlorite is added to the treated water to inactivate pathogens or disease-carrying organisms.

Two chemical storage tanks located inside the Sodium Hypochlorite Facility are used to store the sodium hypochlorite. Four chemical metering pumps are available to deliver the sodium hypochlorite to the various application points. The LAGWRP has two chlorine contact tanks that provide up to three hours of detention at 20 mgd.

LAGWRP doses chlorine solution to other application points on an occasional basis. These include the filter pump wetwell influent channel; the filters for shock chlorination; the RAS pump discharge header for filament control; and the primary clarifier inlet channel for odor control. A summary of equipment for the disinfection process is presented in Table 6.15.

| Table 6.15 LAGWRP Disinfection Design Criteria Wastewater Facilities Plan One Water LA 2040 Plan | |
|------------------------------------------------------------------------------------------------------------------------------------------------------------|--------------------------|
| Unit | Value |
| Chlorine Contact Basins | |
| Number | 2 |
| Tank 1 Area | 177 ft x 65 ft |
| Tank 1 Water Depth | 14 ft |
| Tank 2 Area | 215 ft x 66 ft |
| Tank 2 Water Depth | 14 ft |
| Detention Period at 20 mgd | 3 hours |
| Chemical Storage Tank | |
| Type | Fiber-Reinforced Plastic |
| Number | 2 |
| Volume | 6,500 gal |
| Chemical | Sodium Hypochlorite |
| Concentration | 12.5% |
| Chemical Metering Pumps (2009) | |
| Type | Prominent Pumps |
| Number | 4 |
| Capacity, each | 120 gph |
| <i>Sources: City of Los Angeles Integrated Resource Plan, 2006; City of Los Angeles Recycled Water Master Planning Long-Term Concepts Report: Volume 2</i> | |

6.1.9.1 Operation

The normal application point for disinfection is the filter effluent channel before the flow splits and feeds both chlorine contact tanks. Chemical feed to this point typically requires one metering pump. A combination of an ORP (oxidation-reduction potential) meter and chlorine residual analyzers are utilized to automatically control the dosing process.

Ammonia hydroxide is added to the secondary effluent to reduce the formation of THMs as a disinfection byproduct. The ammonia will react with the chlorine disinfectant to produce chloramines, an effective disinfectant. Chloramines produce less THMs than free chlorine disinfection.

6.1.9.2 Current Performance

The plant maintains the permitted requirement of 0.1 mg/L of residual chlorine in the final effluent, but are looking into other options to replace chlorine in the disinfection process,

particularly to reduce NDMA formation and limit the amount of disinfection byproducts discharged to receiving waters. Ongoing studies are being conducted to address this issue.

Current performance information for the disinfection process is presented in Table 6.16.

| Table 6.16 LAGWRP Disinfection Performance Wastewater Facilities Plan One Water LA 2040 Plan | |
|-------------------------------------------------------------------------------------------------------------|--------------|
| Description | Value |
| Average Chlorine Contact Tank Influent Flow | 14.6 mgd |
| Average Sodium Hypochlorite Usage | 1,101 gpd |
| Average Chlorine Contact Time (CT) | 749 min-mg/L |
| Average Detention Time | 4.7 hr |
| <i>Source: Monthly Performance Reports July 2014 to June 2015</i> | |

As stated above, the disinfection process performs well but future studies and upgrades will help to improve hydraulic capacity and efficiency.

6.1.10 Dechlorination

Dechlorination is the process of removing residual chlorine from effluent before it is discharged to the LA River for the protection of aquatic species. At LAGWRP, dechlorination is accomplished with a dechlorination chamber.

Effluent from the chlorine contact tanks flows by gravity via a 72-inch discharge pipe to the dechlorination chamber where it is dechlorinated with sodium bisulfite. Additional sodium bisulfite can be added at the final weir leaving the overflow weir structure if necessary to ensure that no chlorine residual remains in the plant effluent prior to discharge to the Los Angeles River.

Sodium bisulfite is stored in two, 7,000-gallon chemical storage tanks located next to the overflow weir structure. Four chemical metering pumps deliver the sodium bisulfite to the two application points. Table 6.17 summarizes LAGWRP's dechlorination facilities.

| Table 6.17 LAGWRP Dechlorination Design Criteria Wastewater Facilities Plan One Water LA 2040 Plan | |
|-------------------------------------------------------------------------------------------------------------------|------------------|
| Unit | Value |
| Chemical Storage Tanks | |
| Chemical | Sodium Bisulfite |
| Number | 2 |
| Capacity | 7,000 gal |

| Table 6.17 LAGWRP Dechlorination Design Criteria Wastewater Facilities Plan One Water LA 2040 Plan | |
|-------------------------------------------------------------------------------------------------------------------|-----------------------|
| Unit | Value |
| Chemical Metering Pumps | |
| Type | Prominent Pumps |
| Number | 4 (2 duty, 2 standby) |
| Capacity, each | 68 gph |
| <i>Source: City of Los Angeles Integrated Resource Plan, 2006; Discussions with City staff.</i> | |

6.1.10.1 Operation

Normal dechlorination operation requires two pumps to be in operation while the other two pumps are available as standby units. In the event of a power failure, there are two gravity discharge lines from the chemical storage tanks to the two application points that allow the flow to the LA River to be dechlorinated.

The dechlorinated effluent from the overflow weir structure flows into a 72-inch pipe (75 mgd capacity) towards the river outlet structure. The effluent then flows from the river outlet structure to the LA River through three, 66-inch pipes, and a discharge structure on the eastern bank of the LA River. The effluent is discharged at an unlined point in the river approximately five miles upstream of the Los Angeles Narrows.

6.1.10.2 Current Performance

The average sodium bisulfite usage for the FY14-15 was 644 gpd. At present the dechlorination system operating efficiently and has additional capacity available beyond current usage.

6.1.11 Effluent Water Reuse

LAGWRP produces tertiary effluent compliant with Title 22 standards for disinfected tertiary recycled water. Effluent intended for recycling purposes exits the chlorine contact tanks and flows to the recycled water pump wet well located adjacent to the filter pump wet well.

There are five, 600 hp vertical turbine pumps located at the recycled water pump wet well available to pump recycled water into a 30 inch force main, which conveys the flow approximately one mile to a 2 MG circular storage tank located across the LA River and the Interstate 5 Freeway in Griffith Park. The force main crosses under both the LA River and Interstate 5 Freeway through concrete encasements. The storage reservoir is a steel tank, 110 feet in diameter and 30 feet high, with a maximum water elevation of about 28 feet.

The LADWP and the City of Glendale's Public Service Department distribute the recycled water produced at LAGWRP. The LADWP operates and maintains the recycled water pump station for both agencies. There are currently over forty users of the recycled water. The

recycled water is used mainly for irrigation at multiple locations including Griffith Park and Lakeside Country Club. It is also used in cooling towers at the Glendale Power Plant and for industrial and process purposes at the LAGWRP.

6.1.12 Ancillary Facilities

There are a number of facilities at LAGWRP that are not a direct part of the process train. These facilities include the maintenance building, administration building, and personnel building.

6.1.12.1 Los Angeles Wastewater Integrated Network System (LAWINS)

The initial control systems at LAGWRP were programmable logic controllers (PLCs) which were eventually upgraded to a DCS. The current DCS is now being updated by Honeywell International Incorporated. In 2011, Honeywell International Incorporated was awarded a 15-year contract to overhaul the technology controlling the City's wastewater treatment system. The Honeywell DCS technology will allow the City to link its four main treatment plants with geographically dispersed pumping stations to give operators the ability to effectively and efficiently control and monitor the entire system, more than 500 square miles of the City's service area, from one central location. Updates include documenting wire terminations, designing and replacing control systems hardware, field cabinetry, development of software, design of control strategies and programming control codes and graphic control screens, design and installation of fiber optic backbone, and process data integration to LASAN business network. The migration of the existing control system to Honeywell DCS is expected to be completed in 2016-2017.

6.1.13 Recent and Ongoing Plant Upgrades

A variety of projects for each of the processes at LAGWRP have been planned or are currently underway to increase the plant's overall reliability and efficiency. The following projects in Table 6.18 replaced, rehabilitated or upgraded process components at the plant, and were in construction by March 2017. Planned projects that begin construction after March 2017 are summarized in Section 6.5 and listed in Appendix H. Planned completion dates are shown in parenthesis at the end of the description. Projects that have been completed are noted as such.

| Table 6.18 LAGWRP Recent and Ongoing Plant Upgrades Wastewater Facilities Plan One Water LA 2040 Plan | | | |
|----------------------------------------------------------------------------------------------------------------------|------------------|------------------------|---------------------------------------------------------------------------------------------------------------------------------------|
| Process | Project # | Project Title | Project Description |
| Preliminary | 4172 | Headworks Improvements | This project removed and replaced two bar screens and installed a third bar screen adjacent to the existing two bar screens. (4/2019) |

| Table 6.18 LAGWRP Recent and Ongoing Plant Upgrades Wastewater Facilities Plan One Water LA 2040 Plan | | | |
|----------------------------------------------------------------------------------------------------------------------|------------------|---------------------------------------------|--------------------------------------------------------------------------------------------------------------------------------------------------------------------------------------------------------------------------------------------------------------------------------------------------------------------------------------------------------------------------------------------------------------------------------------------------------------------------------------------------------------|
| Process | Project # | Project Title | Project Description |
| Primary | 4197 | Primary Tanks & Sec. Clarifiers Guard Rails | This project installed the removable guard rail support system on all primary tanks and secondary clarifier tanks for compliance with California Building Code. (Complete) |
| Aeration Tanks | 4151 | NdN Blower Installation | This project removed two existing blowers (17,500 scfm each) and replaced them with three new blowers (27,000 scfm each). (Complete) |
| Aeration Tanks | 4163 | NdN Blower Procurement | This capital improvement project involved the procurement from Siemens of the blowers installed in CIP #4151. (Complete) |
| Process Air System | 4158 | HPE & Air Piping Improvements | This project demolished and replaced approximately 9,000 feet of existing process piping at LAGWRP, including HPE water lines, process air lines, and instrument air lines. Nearly all of the piping replaced was carbon steel, and was replaced with stainless steel piping. There were approximately 22 separate piping scope items. Several flowmeters were included, as well as any and all accessories required to complete the project. (Complete) |
| Final Clarifiers | 4192 | Channel 4 Diversion Gate | This project installed a new diversion gate to divert plant flow to an in plant sewer during emergencies. This allows the activated sludge process to operate normally and provides the means to bypass secondary treated effluent to the in-plant sewer. In addition, this diversion gate provides operations management with the option of diverting that portion of treated secondary effluent that exceeds the recycled water demand, substantially reducing tertiary treatment chemical costs. (4/2018) |
| Filtration | 4136 | Tertiary Filter Replacement | After upgrade of the existing sand filters at DCTWRP, this project relocated several of the existing Aqua Aerobics filters located at DCTWRP to LAGWRP. |

| Table 6.18 LAGWRP Recent and Ongoing Plant Upgrades Wastewater Facilities Plan One Water LA 2040 Plan | | | |
|------------------------------------------------------------------------------------------------------------------------------------------------------------------------------------------|------------------|-----------------------------------------------|---------------------------------------------------------------------------------------------------------------------------------------------------------------------------------------------------------------------------------------------------------------------------------------------------------------------------------------------------------|
| Process | Project # | Project Title | Project Description |
| | | | The existing EIMCO filters (3) will be demolished. (Complete) |
| Dechlorination | 4174 | Pond Membrane Liner | This project replaced the pond liner. (Complete) |
| Dechlorination | 4179 | Bisulfite Facility Improvements | This project replaced the two bisulfite tanks and all associated piping with heat traced and insulated tanks to prevent crystallization. This project also added new recirculation pumps to recirculate the sodium bisulfite within the system. Power needed to be provided to the tanks to insure the heat tracing is maintained continually. (7/2019) |
| Ancillary Facilities | 8417 | Maintenance Building Locker Room Improvements | This project replaced toilets, plumbing, sinks, exhaust fans, fixtures and mirrors in the maintenance building locker rooms. (11/2019) |
| Ancillary Facilities | 4181 | Administration Building HVAC Replacement | This project replaced the HVAC system at the LAGWRP administration building. (12/2018) |
| <i>Sources: Wastewater Treatment Plants Master Schedule, City of Los Angeles Bureau of Engineering; Wastewater Capital Improvement Program, Clean Water Program, City of Los Angeles</i> | | | |

In addition to the listed improvements above, construction is underway to divert additional sewage flows from the City of Glendale to LAGWRP via Chevy Chase Drive that would otherwise continue to the downstream HWRP. The diversion will save treatment fees typically paid to the City of Los Angeles for treatment at HWRP and will create redundancy in the sewer system to prevent back-ups in the City of Glendale. It will also increase the amount of recycled water LAGWRP is able to produce by providing the plant with more steady flows.

6.2 IN-PROGRESS PROJECT

In-Progress Projects are planned supply projects for groundwater, recycled water, and stormwater that are expected to be implemented outside and independent of the One Water LA 2040 Plan. For LAGWRP, only one In-Progress Project has been identified and is outlined in Table 6.19. The Expansion of NPR per the LADWP 2015 UWMP estimates an additional 3,500 AFY of recycled water demand in the Metro area. LAGWRP currently

meets all recycled water demands in the Metro Area and would continue to do so for the customers identified by this project. Implementation of this project would not require changes to the plant.

| Table 6.19 LAGWRP In-Progress Project Wastewater Facilities Plan One Water LA 2040 Plan | | | |
|--------------------------------------------------------------------------------------------------------|-------------------|----------------------------------------------|-------------------------------|
| Title | Type | Estimated Yield (Normal Year) | Capital Cost (\$M) |
| LAGWRP Increase Recycled Water Demand per 2015 UWMP | Non-Potable Reuse | 3,500 AFY (3 mgd) | \$72.5 |

6.3 FUTURE SYSTEM NEEDS EVALUATION

The previous section discussed LAGWRP's existing facilities, recent upgrades, and in-progress projects related to water reuse. In order to optimize plant operations and maximize water reuse potential, future integration opportunities for LAGWRP have been examined. This section discusses:

- Projected future flows and availability for water reuse
- Future integration opportunities (concept options) formulated for LAGWRP
- Preferred Approach

The preferred approach presented provides for multiple future scenarios based upon the occurrence of defined "trigger" events.

6.3.1 Flow Evaluation

In order to identify which options could be implemented at LAGWRP, an analysis of flows was performed to understand which flows are available for water reuse. This section discusses the current and projected influent and effluent flows, which are key in evaluating the future projects at LAGWRP.

6.3.1.1 LAGWRP Influent Flows

The major trunk sewer in the LAGWRP sewershed area is the NOS. Residential, commercial, and industrial flows from this trunk line to LAGWRP for treatment are estimated to be approximately 17 mgd on average for 2016. Solids residuals resulting from LAGWRP treatment are discharged to HWRP along with bypass wastewater, all of which are treated at the HWRP. The amount treated at the plant is determined by LAGWRP effluent water reuse demand.

Dry and Wet Weather Flow Diversion

Implementation of dry weather low flow diversions would add minimal influent flows. Modeling efforts, developed for the concept description sheets as part of Volume 5, have projected up to an additional 0.16 mgd of dry weather flow diversion. Wet weather flow diversions could bring an additional 0.1 mgd, on average to LAGWRP. Table 6.20 shows the projection of influent flows to LAGWRP.

| Table 6.20 LAGWRP Projected Wastewater Flows Wastewater Facilities Plan One Water LA 2040 Plan | | | | |
|---------------------------------------------------------------------------------------------------------------------------------------------------|---------------------------------------------------------|---------------|---------------|---------------|
| Flow Source | Projected Wastewater Flows by Year⁽¹⁾ | | | |
| | 2016 | 2020 | 2030 | 2040 |
| Wastewater Influent ⁽²⁾ | 17 mgd | 21 mgd | 22 mgd | 22 mgd |
| Future Dry Weather LFDs ⁽³⁾ | - | - | 0.16 mgd | 0.16 mgd |
| Totals⁽⁴⁾ | 17 mgd | 21 mgd | 22 mgd | 22 mgd |
| Notes: | | | | |
| (1) mgd = million gallons per day | | | | |
| (2) Wastewater Influent values reflect Normal Year hydrological conditions. Additional details of these projected flow values are found in TM 2.1 | | | | |
| (3) These LFDs are assumed to be implemented starting in Year 2030. | | | | |
| (4) Flows are rounded to the nearest mgd. | | | | |

6.3.1.2 LAGWRP Planned or Potential Water Reuse

LAGWRP is co-owned by the cities of Los Angeles and Glendale and the City of Los Angeles operates the plant. The cities are each 50 percent owners and therefore are each entitled to 50 percent of the product water. Glendale entered into an agreement with Pasadena in 1993 and renewed again in 2016 in which Pasadena purchased the rights to 60 percent of Glendale's portion of LAGWRP product water. LAGWRP currently produces Title 22 tertiary effluent for a number of water reuse systems, including in-plant usages, NPR for irrigation as well as industrial customers. Glendale and Pasadena are interested in expanding recycled water within their cities, which may impact net quantity of effluent available for other uses.

LASAN currently has an ongoing project (LAGWRP Primary Effluent Equalization Storage – CIP 4176) which will both increase treatment capacity and provide equalization at LAGWRP, as shown on Figure 6.5. The project will construct the additional treatment facilities and will expand the plant's treatment capacity to accept projected future flows. The project will also provide hydraulic relief of the wastewater collection system and facilitate increased production of recycled water by storing peak flows to supplement periods of low flow.

6.3.1.3 Concept Option Flow Assumptions

The concept options consist of various potable reuse options. The estimated yield associated with the potable reuse options are dependent on the quantity of LAGWRP flows available for water reuse. The estimated available flow for additional water reuse is limited to roughly 5 mgd or 6,000 AFY. This is due to the flows that are already allocated to the uses identified in Table 6.21 and Figure 6.4.

| Table 6.21 LAGWRP Flow Assumptions Wastewater Facilities Plan One Water LA 2040 Plan | |
|-----------------------------------------------------------------------------------------------------|-------------------|
| Flow Component | Flow (mgd) |
| LAGWRP 2040 Project Influent Flow | 22 |
| City of Glendale ⁽¹⁾ | -11 |
| In-Plant Uses | -0.8 |
| NPR Demands | -4 |
| Waste Discharge and Bypass to HWRP | -0.5 |
| Available Flows for Water Reuse | 0-5.7 |
| Note: | |
| (1) City of Glendale co-owns LAGWRP, Glendale is entitled to 50% of the flows | |

A conservative estimate of 5 mgd was used to account for the remaining flows available at LAGWRP for water reuse. This flow may vary due to conservation, and the amount of flow bypassed to HWRP. This value was used for the sizing of facilities and equipment required for each concept option as discussed in greater detail in Section 6.3.2.

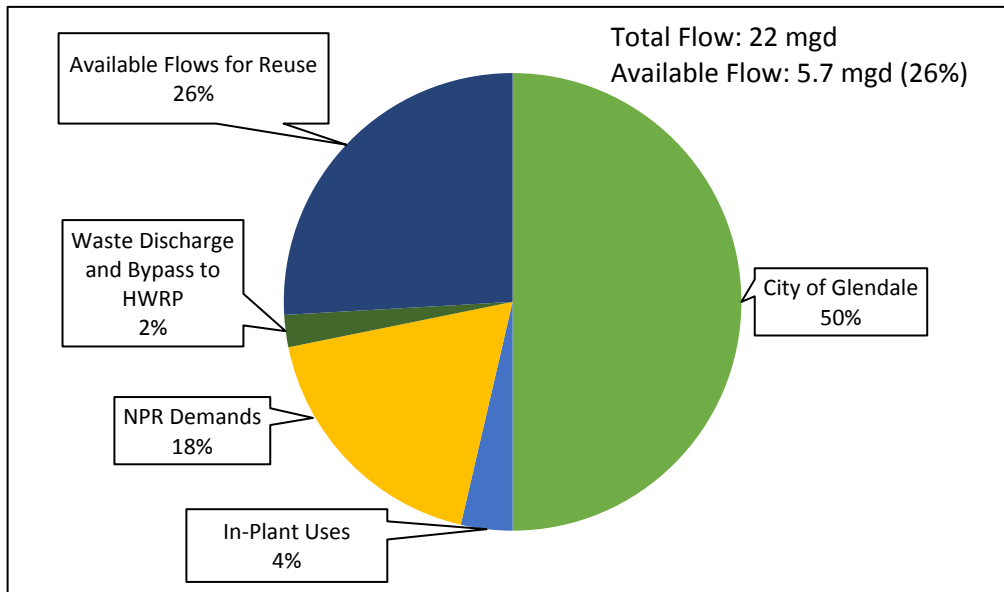

Figure 6.4 Estimated Flow Availability for Water Reuse from LAGWRP (2040 Projection)



 Project Component

Figure 6.5
LAGWRP Primary Effluent Equalization Storage
One Water LA 2040 Plan

6.3.2 Concept Options Development

The preliminary list of concept options that support a locally sourced water supply was developed through workshops that solicited ideas and input from a workgroup as well as community stakeholders. This workgroup included contributors from an array of communities, LASAN, LADWP, other City Bureaus and Departments and select technical advisors. These ideas resulted in the development of concept options within the 2040 planning horizon. Concept options represent new concepts that have not been previously evaluated by the City.

With this methodology, a list of 27 concept options was developed for the entire system. Of these 27 concept options, two concept options were identified for LAGWRP. Determination of LAGWRP's future system needs were based on previous master plans, planning documents, discussions with City staff, and brainstorming sessions. The concept options are preliminary in nature and is not a commitment to level or quantity of treatment.

Table 6.22 shows the concept options associated with LAGWRP, including the normal year estimated yield and associated capital costs.

| Table 6.22 LAGWRP Concept Options Wastewater Facilities Plan One Water LA 2040 Plan | | | | | |
|----------------------------------------------------------------------------------------------------|-------------------------------------------------|------------------------------------------------------|--------------------------------------|-----------------------------------------|--------------------------|
| Concept Option # | Title | Strategy | Estimated Yield (Normal Year) | Capital Cost (\$M)⁽¹⁾ | Unit Cost (\$/AF) |
| 17 | LAGWRP to Headworks Reservoir | Potable Reuse with Treated Water Augmentation | 6,000 AFY (5 mgd) | \$140 | \$1,500 |
| 23 | Increase Recycled Water Demand beyond 2015 UWMP | Non-Potable Reuse | 3,500 AFY (3 mgd) | \$70 ⁽²⁾ | \$2,100 |

Note:

(1) Total Concept Option cost includes a variety of project components including treatment facilities, conveyance, and injection and extraction facilities. Not all costs pertain to the Wastewater Facilities Plan.

(2) This capital cost reflects the proportion of costs specifically for LAGWRP to implement Concept Option #23 (Increase Recycled Water Demand beyond 2015 UWMP). The cost was calculated using proportions of yield and cost relative to overall concept implementation cost.

(3) Bold indicates a Priority A Concept Option

6.3.3 Preferred Approach

As part of the WWFP development, each of the concept options listed above was reviewed to identify improvements that would be needed to treat and convey the product water. This analysis included preliminary sizing of treatment process modifications, location, and cost

estimates. Based on the overall concept score, cost estimates, and portfolio evaluation results, the concept options were prioritized. To guide the City with prioritization and the decision-making process related to these long-term water reuse options, a trigger-based implementation strategy was developed.

Figure 6.6 graphically depicts the triggers and the priority of implementation. The most preferred concept option is indicated as "Priority A", while the second best concept option is identified as "Priority B" and third best as "Priorities C".

The most critical trigger of highest ranked potable reuse opportunity (Concept Option #17 - LAGWRP to Headworks Reservoir) is the adopting of potable reuse with treated water augmentation regulations that would allow this type of water reuse practice.

If the potable regulations are not accepted within a desired timeframe or if the City prefers a more conventional form of water reuse, the Priority B Concept Option #23 (NPR expansion beyond 2015 UWMP) could be considered for the remaining available flows. The most critical trigger for this option is new customer demand that is cost-effective to serve, considering the customer's location, demand size, demand variability.

LA-Glendale Water Reclamation Plant

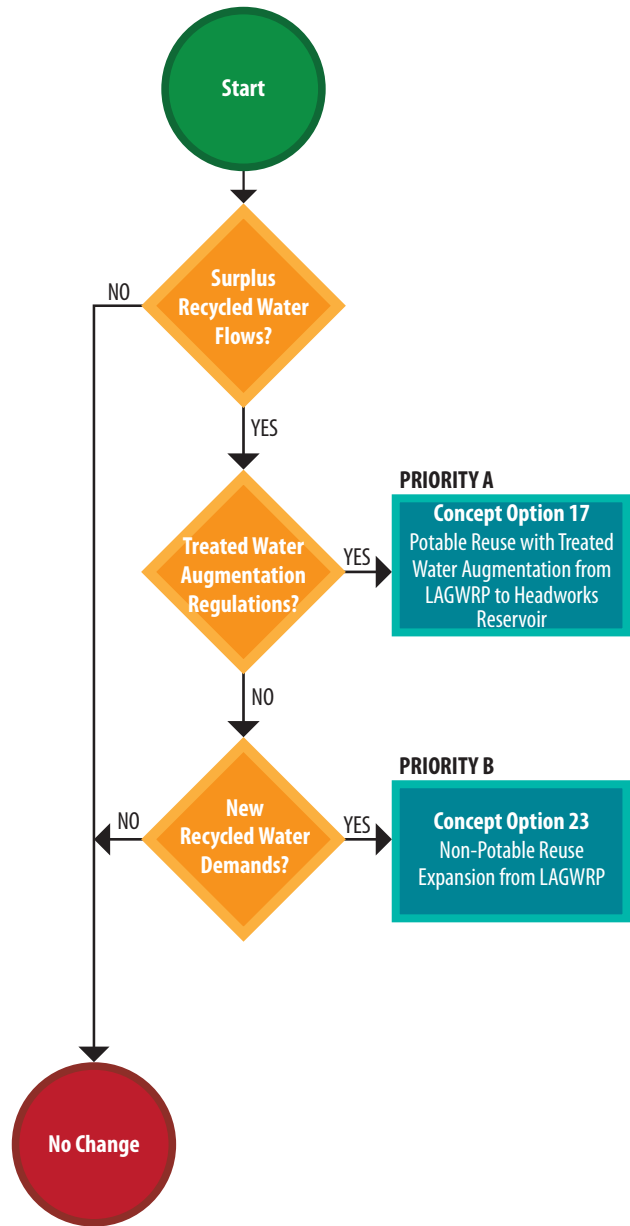

LEGEND & ACRONYMS

- ◆ Trigger
- Concept Option
- Flow Management Option

| | |
|--------|-----------------------------------------------------|
| DCTWRP | Donald C. Tillman Water Reclamation Plant |
| GWR | Groundwater Replenishment Project |
| HWRP | Hyperion Water Reclamation Plant |
| LAGWRP | LA-Glendale Water Reclamation Plant |
| RWQCB | Regional Water Quality Control Board |
| TIWRP | Terminal Island Water Reclamation Plant |
| WRD | Water Replenishment District of Southern California |

Disclaimer: At each trigger (decision point), evaluate all triggers and concept option priorities to consider changed circumstances in the future.

Figure 6.6
Trigger-Based Implementation Strategy for LAGWRP
One Water LA 2040 Plan
Summary Report

6.3.4 Concept Option #17 (LAGWRP to Headworks Reservoir)

This concept option is estimated to yield 6,000 AFY (5 mgd) of advanced treated water during normal, wet, and dry years. This yield is based on the average remaining flow available for further treatment after NPR demand is met. The expected timeline for the implementation of this concept is 2035-2040. Figure 6.7 shows a process concept flow schematic for the LAGWRP to Headworks Reservoir concept option. A system aerial map is shown on Figure 6.8.

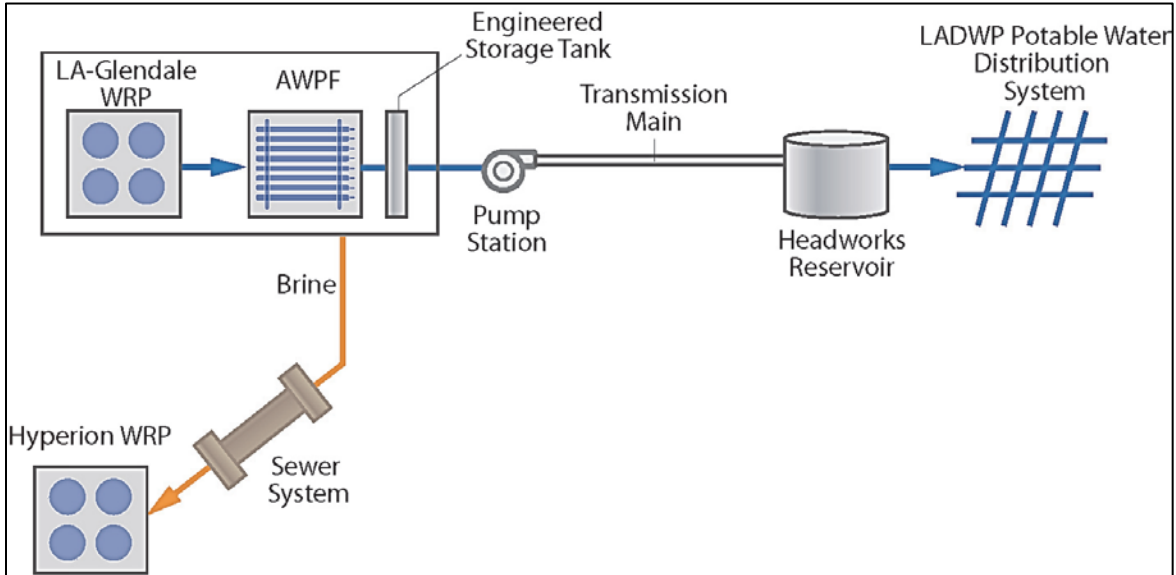
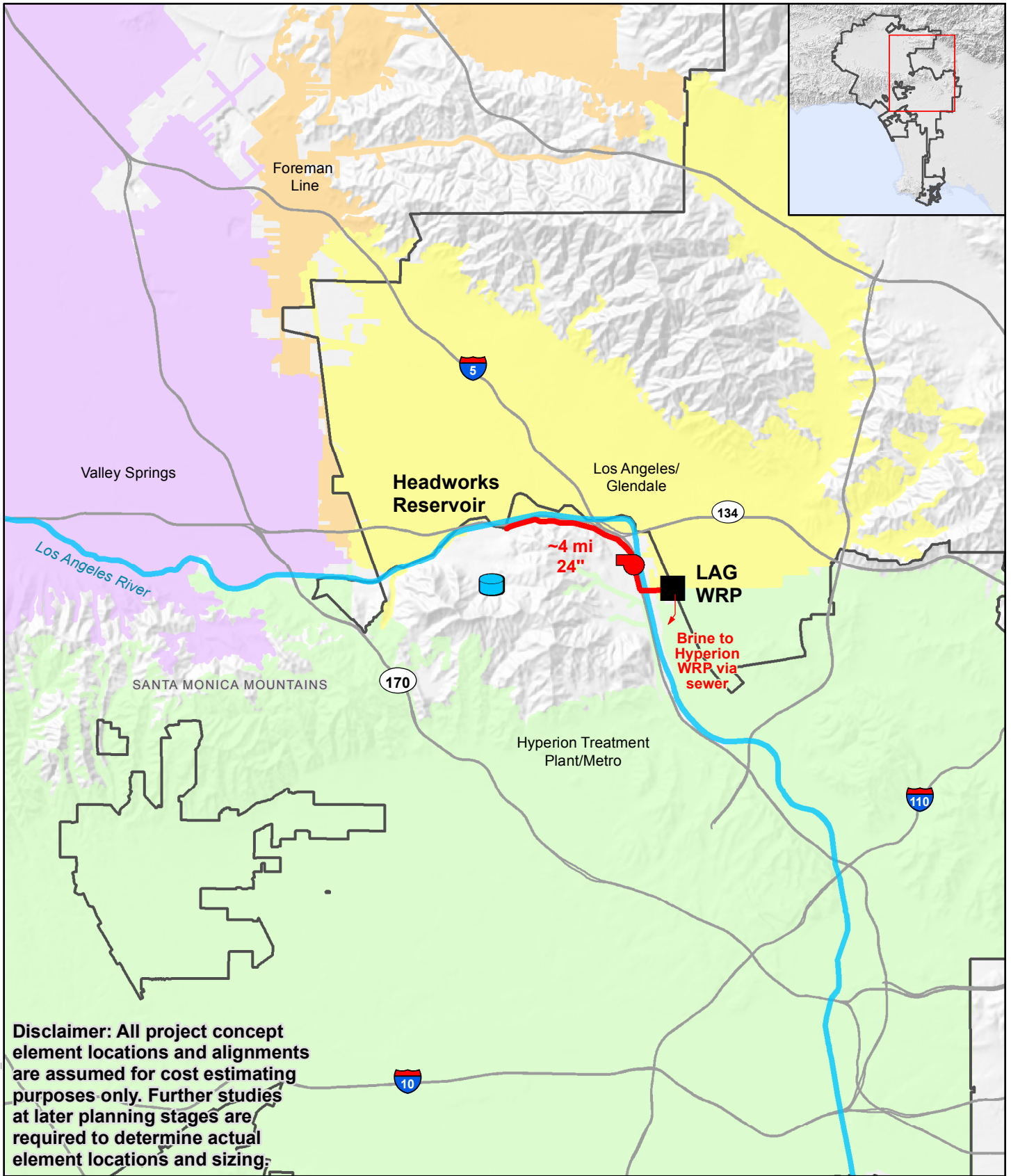

Figure 6.7 Process Flow Schematic for Concept Option #17 (LAGWRP to Headworks Reservoir)

6.3.4.1 System Upgrades

To deliver the water from LAGWRP to the Headworks Reservoir, four miles of 24-inch diameter transmission pipeline may be required (see Table 6.23). Pipeline construction would have to cross under the I-5 in the vicinity of Griffith Park and may lead to construction challenges. This pipeline would be connected to a new 200 hp pump station located at LAGWRP.

| Table 6.23 System Upgrades for Concept Option #17 (LAGWRP to Headworks Reservoir) Wastewater Facilities Plan One Water LA 2040 Plan | |
|----------------------------------------------------------------------------------------------------------------------------------------------------------------|----------------------------------|
| Description | Quantity |
| Estimated Yield (Normal/Wet/Dry Year) | 6,000 AFY (5 mgd) ⁽¹⁾ |
| Conveyance Pipeline | 4 miles of 24-inch diameter |
| Pump Station | 200 hp |
| Note: (1) City of Glendale co-owns LAGWRP, Glendale is entitled to 50% of the flows | |



Disclaimer: All project concept element locations and alignments are assumed for cost estimating purposes only. Further studies at later planning stages are required to determine actual element locations and sizing.

Legend

- Existing Water Reclamation Plant (WRP)
- City of Los Angeles
- Sewershed
- Existing Reservoir
- Pump Station
- Pipeline
- Brine



Hillshade Source: CalAtlas
<http://www.atlas.ca.gov>

Figure 6.8
System Upgrades for
Concept Option #17
(LAGWRP to Headworks Reservoir)
 One Water LA 2040 Plan

Document Path: E:\JACK\EBK\UPO\LA\1\MXD\FactSheet_Clean.mxd



6.3.4.2 LAGWRP Upgrades

This project could require a new AWPf to be constructed at LAGWRP that could meet the average yield of 5 mgd. Flows not required to meet current NPR demands would be diverted to the AWPf. The AWPf would treat the recycled water to match potable reuse treated water augmentation requirements at the time of project implementation, which is assumed to consist of ozone/biologically active filters (O₃/BAF), UF, RO, and UV/AOP. The AWPf would be sized to accept an inflow of up to 8 mgd with a 20 percent assumed brine loss. A 1 MG engineered storage tank may also be required to provide 3 hours of detention time. Brine disposal could be diverted to the plant waste drain and conveyed to HWRP. Per discussions with City staff, an alternative location for the AWPf could be adjacent to the Headworks Reservoir. The feasibility of this alternative location could be evaluated in the future.

There is limited space available around LAGWRP, however, potential locations of the AWPf include a parking lot on the east side of the plant, the site of the demolished EIMCO filtration units or the location of the Chlorine Contact Tanks if they are replaced with UV or ozone disinfection.

A new pump station could also be constructed to convey the product AWPf water to the Headworks Reservoir. The pump station is sized to meet the demands of the AWPf and could be co-located with the AWPf. Potential process locations for a 5 mgd AWPf, storage tank and pump station are shown on Figure 6.9. The final location of these upgrades would be determined during detailed design should this concept option be selected for implementation. Preliminary design criteria yielding an approximate required footprint is shown in Table 6.24.

The key benefits associated with Concept Option #17 (LAGWRP to Headworks Reservoir) consist of:

- Expands LAGWRP's treatment technology and increases flows available for water reuse
- Expands use of potable reuse with treated water augmentation

Moreover, this concept option helps fulfill the following One Water key objectives and guiding principles:

- Implement, monitor, and maintain a reliable wastewater system
- Improve local water supplies reliability
- Integrate management of water resources and policies
- Increase climate resilience



- Primary Effluent Equalization Storage Project
- Potential AWWP Location

Figure 6.9
Potential Process Location for
Concept Option #17
(LAGWRP to Headworks Reservoir)
 One Water LA 2040 Plan

| Table 6.24 Design Criteria for Concept Option #17 (LAGWRP to Headworks Reservoir)⁽¹⁾ Wastewater Facilities Plan One Water LA 2040 Plan | | |
|-------------------------------------------------------------------------------------------------------------------------------------------------------------------------------------------------------------------------------------------|-----------------|--------------|
| Description | Quantity | Units |
| Tertiary Effluent (Feedwater) | 8 | mgd |
| Ozone Dose | 10 | mg/L |
| Generator Size | 330 | lbs/day |
| Generator Number | 2+1 | |
| Generator Footprint | 1,200 | sq ft |
| Ozone Contactor | Serpentine | |
| Number | 2+1 | |
| Ozone Contactor Footprint | 1,200 | sq ft |
| Ozone gas concentration | 12 | % |
| Days of Storage | 7 | days |
| Required Storage | 39,000 | lb |
| Required Storage | 4,100 | gallons |
| LOX Tanks | 2 | quantity |
| Configuration | Horizontal | |
| Tank Size | 4,000 | gallons |
| LOX Footprint | 400 | sq ft |
| BAF Filters | 2+1 | quantity |
| BAF Permeate Flow ⁽²⁾ | 7.9 | mgd |
| BAF Footprint | 3,000 | sq ft |
| MF/UF Permeate Flow ⁽³⁾ | 7.50 | mgd |
| MF/UF Footprint | 3,800 | sq ft |
| RO / UV/AOP Permeate Flow ⁽⁴⁾ | 6 | mgd |
| RO / UV/AOP Footprint | 6,000 | sq ft |
| Brine Flow | 1.5 | mgd |
| Chemical Facility Footprint | 6,000 | sq ft |
| Product Water Storage | 1.0 | MG |
| Product Water Storage Footprint | 3,000 | sq ft |
| Product Water Storage Hydraulic Retention Time | 3.0 | hr. |
| Pump Station | 200 | hp |
| Pump Station Footprint | 1,000 | sq ft |
| Assumptions: | | |
| (1) Process sizing is based off assumptions in Chapter 2 and the San Diego PureWater Program which has a similar process train. | | |
| (2) BAF Recovery is assumed at 99% | | |
| (3) MF Recovery is assumed at 95% | | |
| (4) RO Recovery is assumed at 80% | | |
| (5) Footprint sizes are estimated based on general process, electrical and instrumentation equipment that would be required. These estimates are conservative and would be further refined during detailed design upon project selection. | | |

6.3.4.3 Additional Projects for Consideration

In addition to the Concept Options above, this sections summarizes concepts that may be considered in the future. Table 6.25 summarizes these potential concepts.

| Table 6.25 Additional Projects for Consideration Wastewater Facilities Plan One Water LA 2040 Plan | |
|-------------------------------------------------------------------------------------------------------------------|-----------------------------------------------------------------------------------------------------------------------------------------------------------------------------------------------------------------------------------------------------------------------------------------------------------------------------------------------------------------------------------------------------------------------------------------------------------------------------------------------------------------------------------------------------------------------------------------------------------------------------------------------------------------------------------------------------------------------------------------------------------------|
| Process | Concept Description |
| Collection System | Implement Sewer Monitoring and Routing Terminal (SMART Sewer) that will be a system of flow monitoring or sewer d/D recordings at key stations with the resulting data utilized in a near real time model to determine available sewer capacity such that wet weather storm flows could be routes or diverted into the collection system at controlled interconnections. All of these actions would be monitored and controlled at a central terminal. This is a sewer system inflow strategy to control stormwater flows in sewers and utilize available capacity for flow equalization. Continued control of sulfides to protect the integrity of concrete sewers and monitoring of critical points in consideration of low flows due to conservation. |
| Advanced Treatment | Conduct a brine disposal technology evaluation, such as brine crystallizers or concentrators, to minimize the brine going to HWRP. |
| General | Perform Plant Optimization Study to identify biggest costs to LAGWRP. LASAN should continue their research and product evaluation to identify new technologies that will minimize power and chemical usage throughout the plant. |

These concepts are preliminary in nature and a scope would need to be developed should the LASAN LAGWRP staff decide to evaluate them further.

6.4 CLIMATE RISK AND RESILIENCE ASSESSMENT

Climate change is projected to impact the City's wastewater and stormwater systems in a variety of ways. The wastewater systems consist of sewer systems, sewage pumping facilities, wastewater treatment facilities and water reclamation facilities. Changes in temperature, precipitation, and sea levels will affect the physical plant and operational vulnerabilities of these facilities and operations.

A climate risk and resilience assessment was performed consisting of scenario development, screening analyses, site visits, risk analyses, and adaptation planning concurrent with meetings with LASAN staff. Current and potential future climate conditions

were incorporated into the assessment and development of recommendations. Subsequently, practical improvements for the WRPs were identified to mitigate these risks.

A detailed description of the climate risk assessment of LAGWRP is included in Chapter 10, while the findings and recommendations are summarized in this section.

LAGWRP is located along the Los Angeles River in a flood hazard zone. Climate change conditions of increasing temperatures and changes in rainfall may affect power supply and flooding hazards. This may change the recurrence interval, extent, and impact of flooding events. Increased temperatures and extreme events may cause more frequent power interruptions at LAGWRP. Assessments were performed on the flooding and power failure risks with climate change considerations to identify future projects that address these risks. The overall current and future climate hazards risk assessment for the LAGWRP is very high due to the flood hazard and backup power deficiency.

Capital and non-capital facility planning recommendations with conceptual construction costs for LAGWRP are as follows:

- Add backup power generation for entire facility - \$4,000,000 construction cost.
- Install backflow prevention gates on outfall to Los Angeles River - \$400,000 construction cost.
- Construct floodwalls with flood-proof gates and other structural enhancements - \$10,000,000 construction cost.
- Evaluate condition of existing submarine doors and include maintenance and regular exercise of doors in the facilities Standard Operating Procedure (SOP).

No additional capital or non-capital resilience improvements are recommended for LAGWRP at this point in time. Other climate change considerations may be assessed in the future.

6.5 LAGWRP ADAPTIVE CIP

A comprehensive wastewater facilities Capital Improvement Plan (CIP) has been developed for all four WRPs and the collection system, located in Chapter 11 of this Volume. The purpose of this section is to summarize the capital improvement projects identified for LAGWRP. The sources used to develop the summary CIP include the Los Angeles Bureau of Engineering (LABOE) Uniform Project Reporting System (UPRS), LASAN Wastewater Capital Improvement Plan (WCIP), LADWP 2015 UWMP, and concept options developed as part of the One Water LA 2040 Plan.

The development of the LAGWRP Adaptive CIP compiles the projects previously discussed in this chapter with the WCIP developed by the City. The projects for LAGWRP are classified as follows:

- In-Progress Projects
- Future integration opportunities (concept options)
- Estimated and Projected CIP

The costs for Estimated and Projected CIP are presented by category and phase, defined in Table 6.26. Project costs are then summarized and escalated based upon implementation schedule. The CIP for LAGWRP represents one component of the overall WWFP Adaptive CIP. The details for cost estimating methodology are summarized in Chapter 11.

| Table 6.26 CIP Terms and Definition Wastewater Facilities Plan One Water LA 2040 Plan | | |
|------------------------------------------------------------------------------------------------------|--------------------------------------------|------------------------------------------------------------------------------------------------------------------------------------------------------------------------------------------------------------------------------------------------------------------------------------------------------------------------------------------------------------------------------|
| Group | Term | Definition |
| Category | Capital Project from WCIP | These projects were previously identified in the WCIP. These projects include new construction, expansion, or renovation that helps maintain or improve a City facility or infrastructure that may be funded by the Capital Budget. |
| | R&R from WCIP | These are projects identified in the WCIP. These projects are needed for the continued operation of the facility in its present form. |
| | Climate Resiliency Projects ⁽¹⁾ | These are projects developed as part of the Plan and identified in Volume 6 Climate Risk and Resilience Assessment for Wastewater and Stormwater Infrastructure. These projects are needed to adapt to environmental conditions due to climate change. |
| | Projected Capital Projects | These are projects not identified in the WCIP and are projected as part of the WWFP in collaboration from City staff. These projects include new construction, expansion, or renovation that helps maintain or improve a City facility or infrastructure that may be funded by the Capital Budget. Project costs were estimated using a methodology described in Chapter 11. |
| | Projected R&R Projects | These are projects not identified in the WCIP and are projected as part of the WWFP in collaboration with City staff. These projects |

| | | |
|---------------------------------------------------------------------------------------------------------------------------------------------------------------------------------------------------------------------|-----------|---------------------------------------------------------------------------------------------------------------------------------------------------|
| Table 6.26 CIP Terms and Definition Wastewater Facilities Plan One Water LA 2040 Plan | | |
| | | may be needed for the continued operation of the facility in its present form. These projects were estimated using the methodology in Chapter 11. |
| Phase ⁽²⁾ | Near-Term | Projects that are planned to be constructed between 2018 to 2020 |
| | Mid-Term | Projects that are planned to be constructed between 2021 and 2030 |
| | Long-Term | Projects that are planned to be constructed between 2031 and 2040 |
| <u>Note:</u> (1) Climate resiliency projects were identified based on the analysis described in Volume 6. (2) The phases were determined by LASAN and LADWP management for all projects included in the Plan. | | |

The following sections use the sources, methodologies, terms and definitions to present the In-Progress Projects, future integration opportunities and Estimated and Projected CIP for the LAGWRP Adaptive CIP.

6.5.1 LAGWRP In-Progress Projects

Table 6.27 summarizes the In-Progress Projects, estimated capital costs, projected construction completion, and resulting phase for LAGWRP. Additional details of the In-Progress Projects were previously summarized in Section 6.2.

| | | | |
|----------------------------------------------------------------------------------------------------------------------------|------------------------------------------------------------------|--------------------------|--------------|
| Table 6.27 Summary of In Progress Project Estimated Costs Wastewater Facilities Plan One Water LA 2040 Plan | | | |
| | Estimated Capital Cost Estimate (\$2017) Millions | Year Complete | Phase |
| In-Progress Projects | | | |
| Expansion of Non-Potable Reuse (NPR) per 2015 Urban Water Management Plan | \$73 | 2019-2020 | Near |
| Total | \$73 | | |

6.5.2 LAGWRP Concept Options

The concept options and priority identification for LAGWRP are summarized in Section 6.3.2. Concept Option #17 (LAGWRP to Headworks Reservoir) was identified as the Priority A concept option. As implementation of this concept option could include both changes to LAGWRP and system changes outside of the plant, only plant-related costs are included in the LAGWRP Adaptive CIP and the WWFP Adaptive CIP. The plant-related

estimated cost for Concept Option #17 (LAGWRP to Headworks Reservoir) in 2017 dollars is \$120 million.

6.5.3 LAGWRP Estimated and Projected CIP

The Estimated and Projected CIP is based on the WCIP, plus the climate risk analysis. In areas lacking any estimate of costs, a set of assumptions are used to develop projected costs for annual capital and replacement and rehabilitation projects. Details of these assumptions are summarized in Chapter 11. The Estimated and Projected CIPs for LAGWRP are provided in Table 6.28 and Figure 6.10. The details of the summary table can be found in Appendix H.

| Table 6.28 LAGWRP Estimated and Projected CIP Wastewater Facilities Plan One Water LA 2040 Plan | | | |
|----------------------------------------------------------------------------------------------------------------|-----------------------------|------------------------------------|------------------------------------|
| | Category | Total (\$2017) Millions | Total (\$2017) Millions |
| Near-Term | Capital Project from WCIP | \$17 | |
| | R&R from WCIP | \$41 | |
| | Climate Resiliency Projects | \$14 | \$72 |
| | Projected Capital Projects | - | |
| | Projected R&R Projects | - | |
| Mid-Term | Capital Project from WCIP | \$1 | |
| | R&R from WCIP | \$15 | |
| | Climate Resiliency Projects | - | \$75 |
| | Projected Capital Projects | \$59 | |
| | Projected R&R Projects | - | |
| Long-Term | Capital Project from WCIP | - | |
| | R&R from WCIP | - | |
| | Climate Resiliency Projects | - | \$80 |
| | Projected Capital Projects | \$60 | |
| | Projected R&R Projects | \$20 | |
| | | Total | \$227 |

Table 6.28 shows that there is roughly an equal amount estimated for each of the three phases. The near-term phase uses the projects identified in the WCIP, whereas projections were used for the long-term phase. The mid-term phase uses a combination of estimates from the WCIP and projections. These projections are to account for future, but undefined

costs that may occur at LAGWRP. The same information is shown graphically on Figure 6.10.

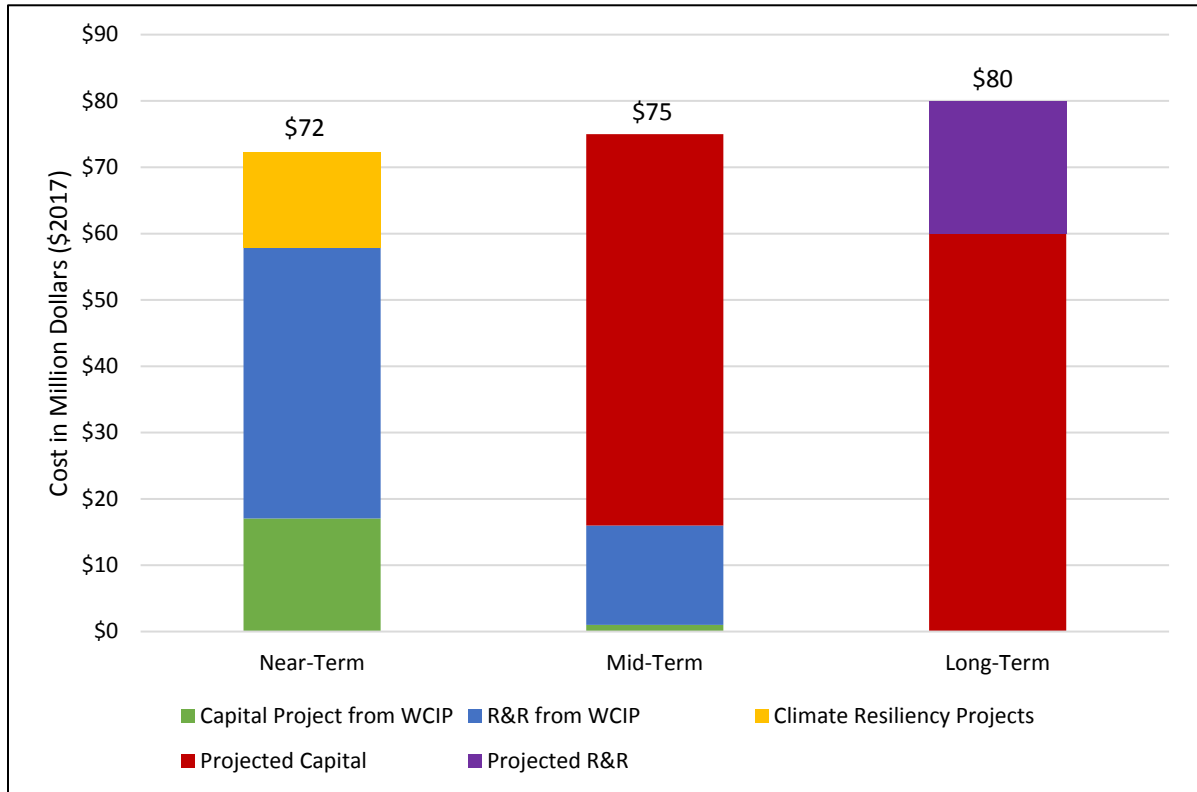

Figure 6.10 Summary of LAGWRP Estimated and Projected CIP Costs

The Projected CIP for LAGWRP earmarks \$72 million in the near-term, \$75 million in the mid-term and \$80 million in the long-term, as seen in Table 6.28 and on Figure 6.10. The near-term phase consists of capital and replacement and rehabilitation projects identified in the WCIP, along with climate resiliency projects. The mid-term consists of minor capital projects from the WCIP, some replacement and rehabilitation projects identified in the WCIP. Both the mid- and long-term phases have significant projected capital costs as well. The long-term consists of solely projected costs, to account for costs that have not yet been identified. The Estimated and Projected CIP costs summarized in Table 6.28 translates to an average cost of approximately \$24 million per year from 2018 to 2020, \$7.5 million per year from 2021 to 2030, and \$8 million per year from 2031 to 2040. As the City defines more projects for LAGWRP, this project CIP summary should be updated to reflect accurate numbers for the mid- and long-terms.

Figure 6.11 presents the same Estimated and Projected CIP information as Figure 6.10, but depicts the total value by percent allocated to each category. The Projected Capital Project category is the largest of the five, as a result of the values calculated for future unidentified costs.

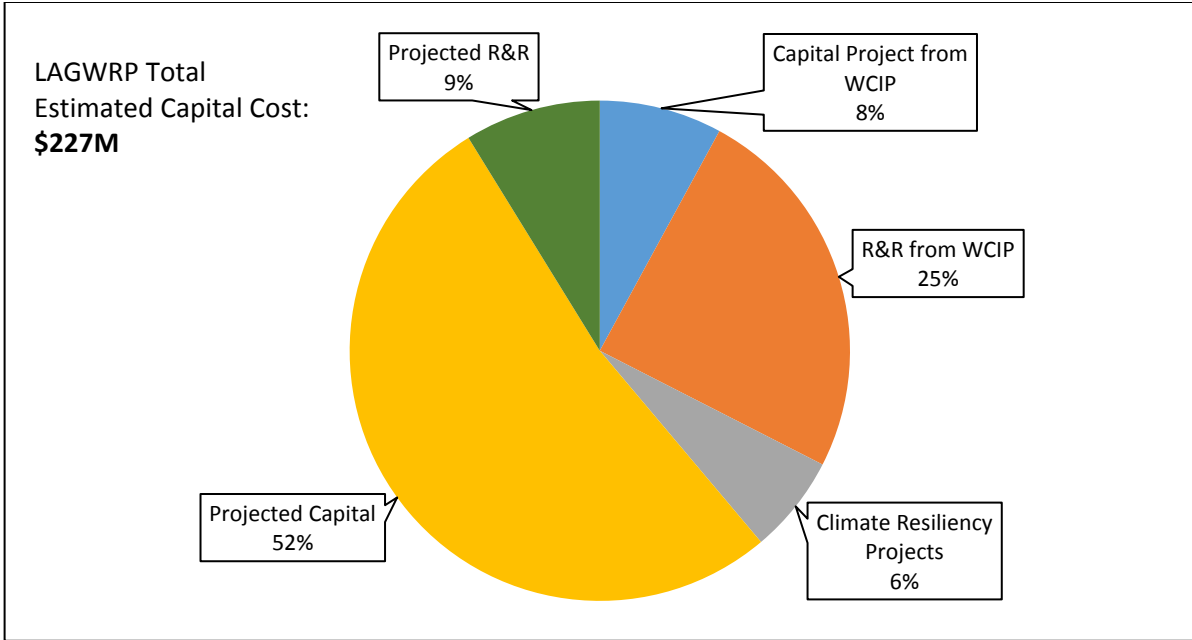

Figure 6.11 LAGWRP Estimated and Projected CIP Costs by Category

6.5.4 LAGWRP Adaptive CIP Summary

The combination of the In-Progress Projects, future integration opportunities, and Estimated and Projected CIP serve as the basis for the LAGWRP portion of the WWFP Adaptive CIP. These three sources of projects are summarize in 2017 dollars in Table 6.29.

| Table 6.29 LAGWRP Adaptive CIP Summary 2017 (\$M) | | | | |
|----------------------------------------------------------|--------------------------------------------|-------------------------------------------|--------------------------------------------|------------------------|
| Wastewater Facilities Plan | | | | |
| One Water LA 2040 Plan | | | | |
| Category | Near-term (2018-2020) (\$M) | Mid-term (2021-2030) (\$M) | Long-term (2031-2040) (\$M) | Total (\$M) |
| In Progress Projects | | | | |
| LAGWRP Increase Recycled Water Demand beyond 2015 UWMP | \$73 | \$0 | \$0 | \$73 |
| Subtotal | \$73 | \$0 | \$0 | \$73 |
| Estimated and Projected CIP Projects | | | | |
| Capital Project from WCIP | \$17 | \$1 | - | \$18 |
| R&R from WCIP | \$41 | \$15 | - | \$56 |
| Climate Resiliency Projects | \$14 | - | - | \$14 |
| Projected Capital Projects | - | \$59 | \$60 | \$119 |
| Projected R&R Projects | - | - | \$20 | \$20 |
| Subtotal | \$72 | \$75 | \$80 | \$227 |

| Table 6.29 LAGWRP Adaptive CIP Summary 2017 (\$M) Wastewater Facilities Plan One Water LA 2040 Plan | | | | |
|--------------------------------------------------------------------------------------------------------------------|--------------------------------------------|-------------------------------------------|--------------------------------------------|------------------------|
| Category | Near-term (2018-2020) (\$M) | Mid-term (2021-2030) (\$M) | Long-term (2031-2040) (\$M) | Total (\$M) |
| Future Integration Opportunities (WWFP Cost Element) | | | | |
| Concept Option #17 (LAGWRP to Headworks Reservoir) | \$0 | \$0 | \$120 | \$120 |
| Subtotal | \$0 | \$0 | \$120 | \$120 |
| Total | \$145 | \$75 | \$200 | \$420 |

The overall CIP in 2017 dollars for LAGWRP is \$420 million, between 2018 and 2040, which equates to roughly \$17.5 million per year. The majority of the expenditures are anticipated to fall within the long-term phase. This is driven by the inclusion of the long-term concept option as well as the estimated CIP values that were calculated. This same information is presented graphically on Figure 6.12.

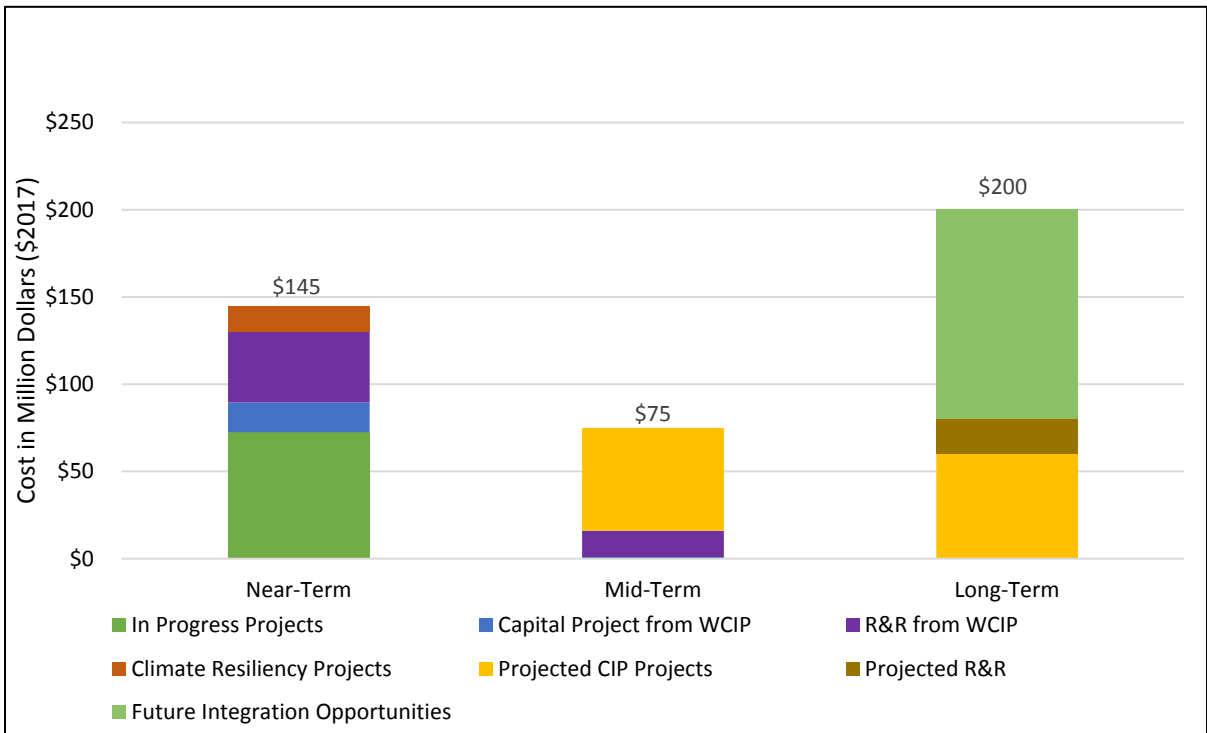

Figure 6.12 LAGWRP Adaptive CIP Summary by Phase

The LAGWRP Adaptive CIP costs summarized in Table 6.29 totals \$145 million in the near-term, \$75 million in the mid-term, and \$200 million in the long-term. These phase totals translate to an average cost of approximately \$48 million per year from 2018 to 2020, \$7.5 million per year from 2021 to 2030, and \$20 million per year from 2031 to 2040.

Figure 6.13 presents the same information but depicts the total value by percent allocated to each category. The Estimated and Projected CIP is the largest of the three categories.

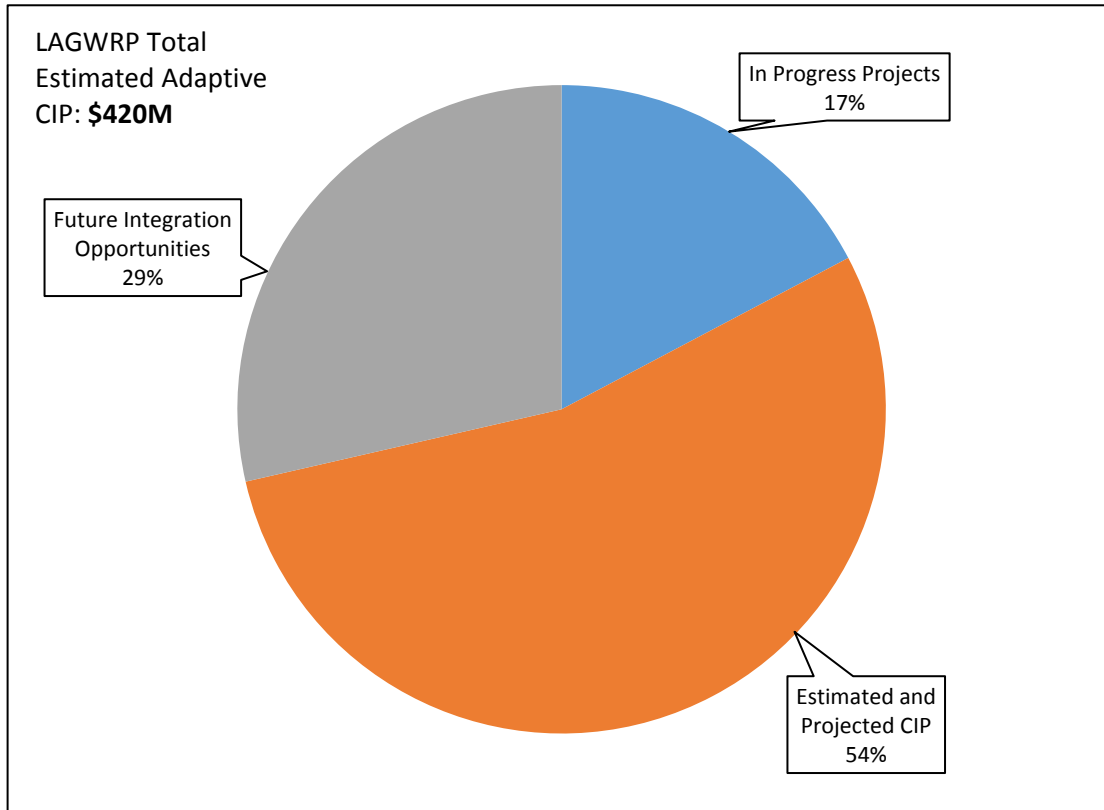

Figure 6.13 LAGWRP Adaptive CIP Summary by Category

The costs in the LAGWRP Adaptive CIP are presented in 2017 dollars but future costs should be adjusted for the time value of money. Section 6.5.5 discusses the escalation methodology used to account for these future values.

6.5.5 LAGWRP Adaptive CIP Net Present Worth Summary

The values for each of the projects were developed in 2017 dollars. Recognizing that the City will not implement all projects immediately, the projects have been divided into phases. The costs for the projects that are scheduled to be implemented in the near, mid, and long-term were adjusted to account for inflation and, escalated at a rate of 3 percent per year. To allow a comparison of costs between phases, the escalated costs were brought back to a present value using a discount rate of 2 percent per year. Discounting the escalated costs yields a net present value and reflects the future values in 2017 dollars.

The net present worth of the LAGWRP Adaptive CIP for all three phases totals \$467 million. For the 2040 planning horizon, this total value equates to \$20.3 million on an annual basis. Figure 6.14 shows how the time value of money impacts each of the phases of the CIP.

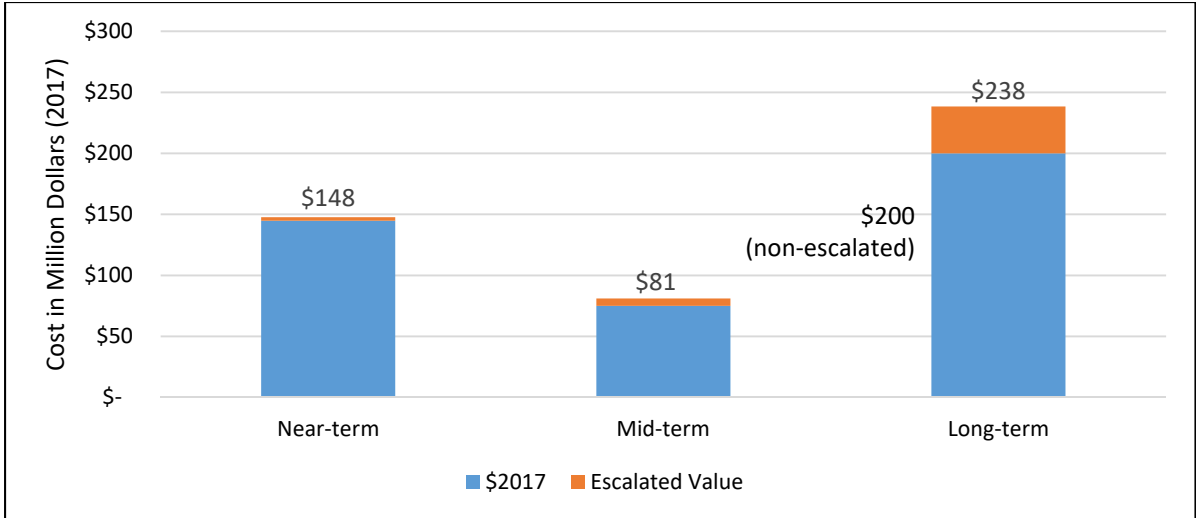

Figure 6.14 Present Worth Comparison: Escalated versus Non Escalated CIP

The long-term phase has the greatest impact on the CIP, due to the large amount of money that needs to be accounted for in today's dollars.

-This Page Left Blank Intentionally-

TERMINAL ISLAND WATER RECLAMATION PLANT

The TIWRP has treated wastewater since 1935. The plant is located on Terminal Island, an island in the Los Angeles Harbor approximately 20 miles south of downtown Los Angeles. It occupies an area of 21.5-acre at the northwest corner of Terminal Way and Ferry Street. The location of this plant is shown on Figure 7.1.

The plant was built originally as a primary treatment facility, and was subsequently upgraded and expanded to include secondary treatment in 1973, tertiary treatment (filtration) in 1996, and 6 mgd of advanced water purification (microfiltration and reverse osmosis) and post-treatment in 2006. In 2017, another 6 mgd of capacity was added to the advanced water purification facility bringing it to a total capacity of 12 mgd. Currently, TIWRP is permitted for 30 mgd ADWF, peak wet weather flow of 55 mgd, of tertiary treatment. An aerial overview of the plant is shown on Figure 7.1.

TIWRP treats wastewater from throughout the TISA, consisting of the communities of Wilmington, San Pedro, Terminal Island, and part of Harbor City. The wastewater treated at TIWRP includes flows from municipal, commercial, and industrial facilities; the total flow into the plant contains about 40 percent municipal sewage and 60 percent industrial waste. Raw wastewater reaches the TIWRP through a series of pumping plants and force mains throughout the TISA. The TISA is shown on Figure 7.2.

This chapter describes the Existing Treatment Process Description, In-Progress Projects, Future System Needs, Evaluation Climate Risk and Resilience Analysis and Adaptive Capital Improvement Plan for TIWRP.

7.1 EXISTING TREATMENT PROCESS DESCRIPTION

This section outlines existing systems at TIWRP, documents plant upgrades, and is organized as follows:

- General plant overview
- Current flows and loadings
- Process descriptions - liquids and solids
- Recent Upgrades

Understanding existing facilities is critical to the assessment of future potential projects to improve performance and enhance water reuse.



Figure 7.1
TIWRP Aerial Overview
One Water LA 2040 Plan

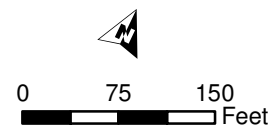

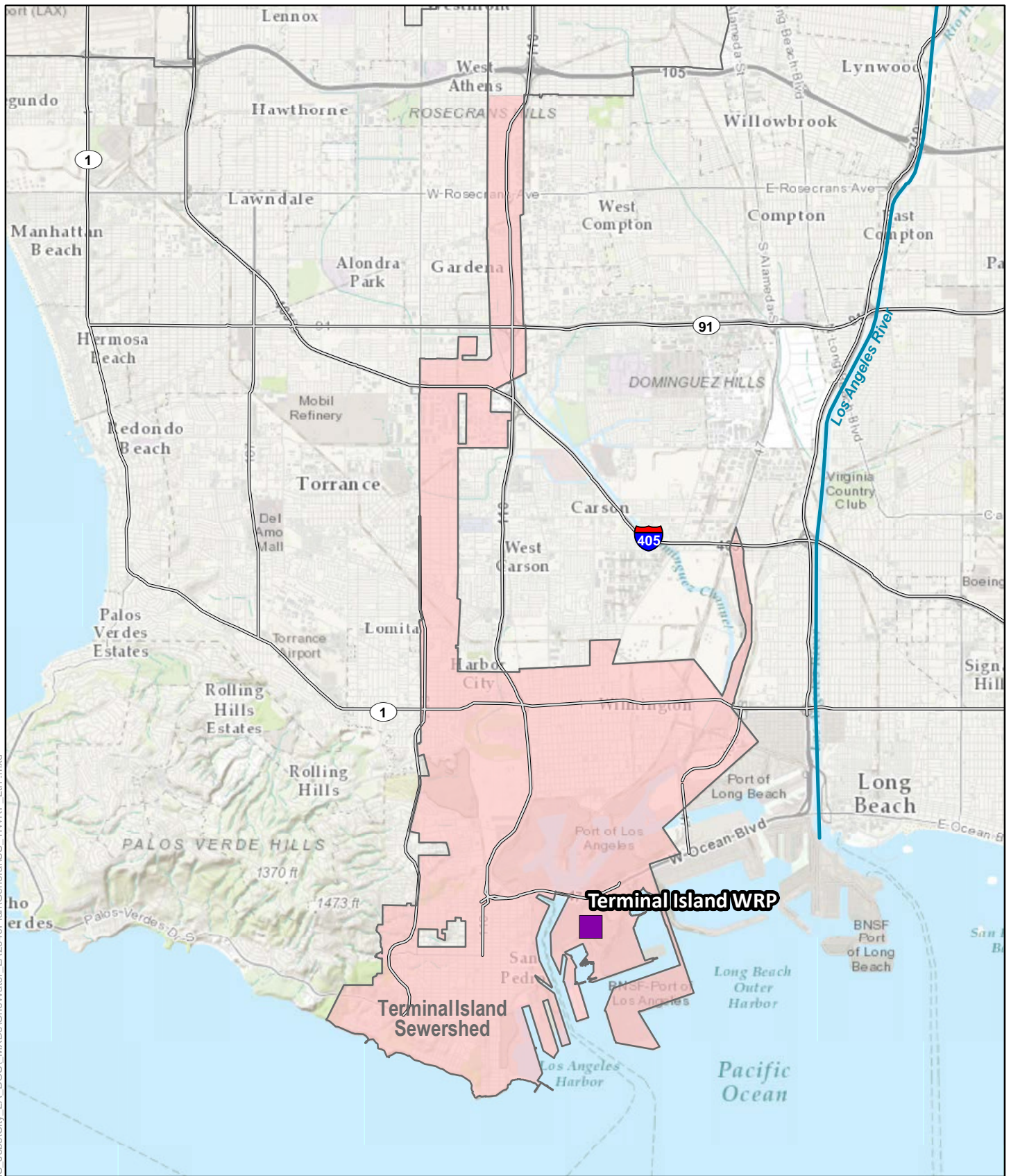

- Existing Water Reclamation Plant (WRP)
- Terminal Island Sewershed

Figure 7.2
TIWRP Location and Sewershed
 One Water LA 2040 Plan

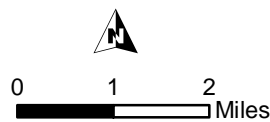

7.1.1 Treatment Process Overview

TIWRP currently operates as a secondary treatment facility with full tertiary filtration followed by advanced water purification. The majority of the effluent produced is recycled to non-potable uses. Brine generated by the AWPF is discharged via outfall to the harbor. Solids management systems include thickening, stabilization and dewatering. The principal means of solids disposal is by injection into a depleted oil formation at a depth of 6,000 feet. This disposal approach is referred to as the Terminal Island Renewable Energy (TIRE) project.

TIWRP is rated and permitted to treat an average flow of 30 mgd. Reductions in industrial discharges and water conservation have reduced flows to the plant. The plant flows in 2016 were 14 mgd.

A plant process flow diagram is shown on Figure 7.3. For the liquid treatment, processes include:

- Preliminary Treatment
- Primary Clarification
- Activated Sludge
- Secondary Clarification
- Tertiary Filtration
- Advanced Water Purification
- Effluent Discharge System

Also shown are the sludge management systems including:

- Secondary Sludge Thickening
- Anaerobic Digestion
- Dewatering
- Sludge Injection

For individual processes and systems, detailed information is provided in Section 7.1.4 through Section 7.1.14.

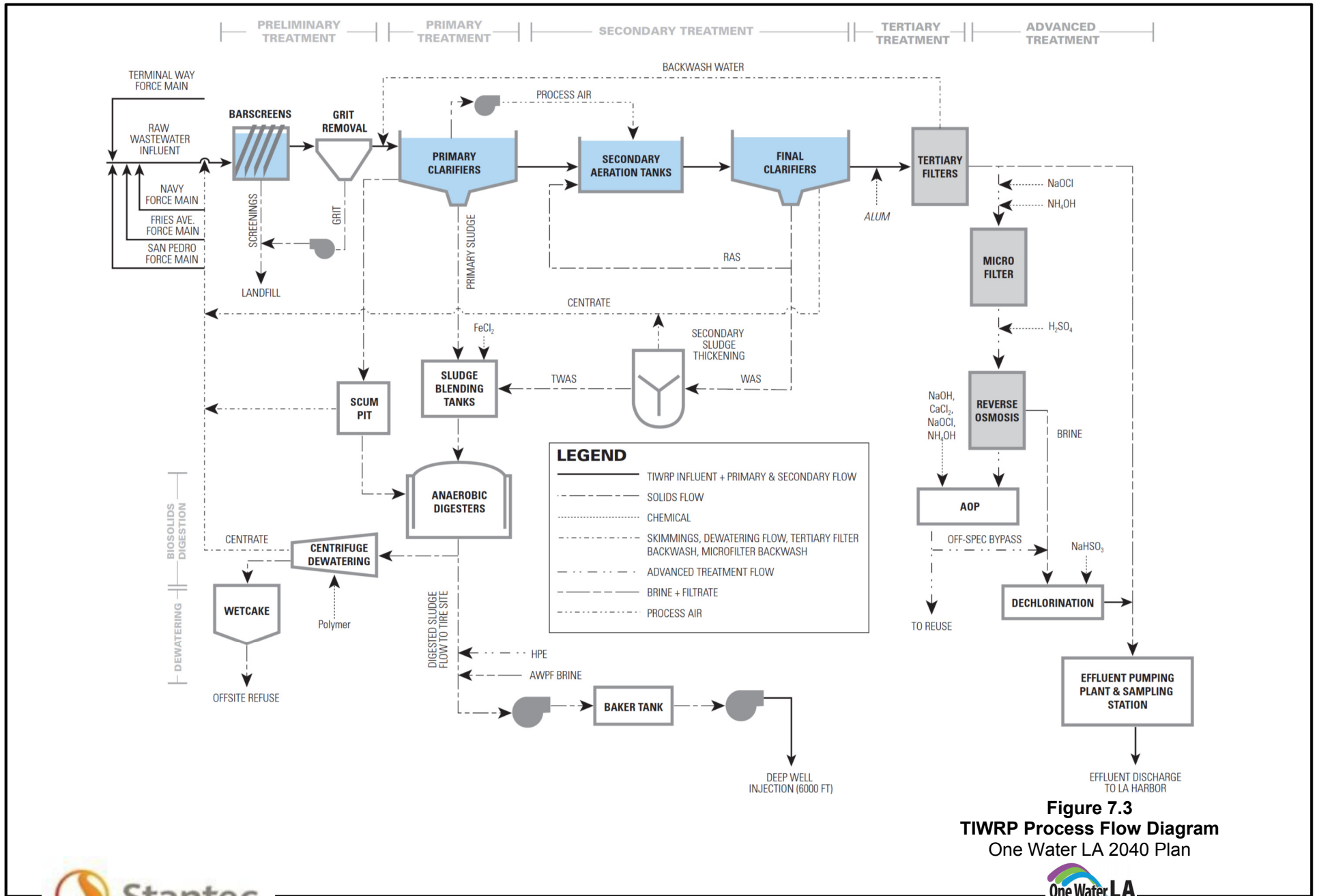

Figure 7.3
TIWRP Process Flow Diagram
 One Water LA 2040 Plan

7.1.2 Influent Flows and Characteristics

The influent sewage source into TIWRP has more industrial than municipal sewage. The source of the flow can impact the design criteria. TIWRP's influent design criteria is shown in Table 7.1.

| Table 7.1 TIWRP Influent Flow and Characteristics Wastewater Facilities Plan One Water LA 2040 Plan | | |
|--------------------------------------------------------------------------------------------------------------------------------------------------------------------------|---------------------|--------------|
| Parameter | Design Value | Value |
| ADWF Capacity | 30 mgd | 14 mgd |
| Design Peak Flow/Max Daily Actual | 50 mgd | 23.6 mgd |
| Average BOD | | |
| Concentration | | 236 mg/L |
| Mass Loading | | 15.5 tpd |
| Average TSS | | |
| Concentration | | 183 mg/L |
| Mass Loading | | 12.0 tpd |
| <i>Sources: Monthly Performance Reports May 2015 to April 2016, Amended Engineering Report for the TIWRP AWPf Expansion: Dominguez Gap Barrier Project (August 2015)</i> | | |

The influent flow of 14 mgd in 2016 is significantly below the plant's 30 mgd rated capacity. The combination of lower flows and constituent concentration for BOD and TSS result in available capacity within the secondary treatment facilities.

7.1.3 Effluent Flows and Characteristics

While the majority of effluent produced is recycled and reused, the plant maintains the ability to discharge effluent to the harbor via its outfall. In accordance with the current NPDES permit, Order No. R4-2015-0119-A01, TIWRP may discharge brine, peak wet weather flows, periods of reduced water reuse demands and approved preventive maintenance activities to the Harbor.

The advanced water treatment processes are addressed in Section 7.1.9. TIWRP is also subject to the recycled regulation under Order No. R4-2003-0134 adopted on October 2, 2003, and the Dominguez Gap Seawater Intrusion Barrier injection regulation under Order No. R4-2003-0025, adopted on January 30, 2016. Table 7.2 summarizes the NPDES constituent permit requirements for TIWRP while Table 7.3 summarizes the NPDES recycled water constituent limits for TIWRP AWPf.

| Table 7.2 TIWRP NPDES Effluent Limitations Wastewater Facilities Plan One Water LA 2040 Plan | | | | |
|-------------------------------------------------------------------------------------------------------------|----------------|------------------------|-----------------------|----------------------|
| Constituent | Units | Monthly Average | Weekly Average | Maximum Daily |
| BOD ₅ | mg/L | 15 | 30 | 40 |
| | lbs/day | 3,800 | 7,500 | 10,000 |
| TSS | mg/L | 15 | 30 | 40 |
| | lbs/day | 3,800 | 7,500 | 10,000 |
| pH | standard units | | 6.5 – 8.5 | |
| Oil and Grease | mg/L | 10 | -- | 15 |
| | lbs/day | 2,500 | -- | 3,800 |
| Settleable Solids | ml/L | 0.1 | -- | 0.3 |
| Total Residual Chlorine | mg/L | -- | -- | 0.1 |
| | lbs/day | -- | -- | 25 |
| MBAS | mg/L | 33 | -- | -- |
| | lbs/day | 8,200 | -- | -- |
| Ammonia Nitrogen | mg/L | 28 | -- | 85 |
| | lbs/day | 7,000 | -- | 21,000 |
| Temperature | °F | | Shall not exceed 86°F | |
| Turbidity | NTU | -- | -- | 2 |
| <i>Source: NPDES Permit No. CA0053856, Order No. R4-2015-0119-A01</i> | | | | |

| Table 7.3 TIWRP NPDES Recycled Water Constituent Limits Wastewater Facilities Plan One Water LA 2040 Plan | | | |
|--------------------------------------------------------------------------------------------------------------------------|--------------|------------------------|----------------------|
| Constituent | Units | Monthly Average | Maximum Daily |
| Oil and Grease | mg/L | 10 | 15 |
| Total Dissolved Solids | mg/L | – | 800 |
| Chloride | mg/L | – | 250 |
| Sulfate | mg/L | – | 250 |
| Boron | mg/L | 6.1 | 1.5 |
| Total Nitrogen | mg/L | – | 5 |
| <i>Source: NPDES Permit No. CA0053953, Order No. R4-2003-0134</i> | | | |

In addition to the constituent limits above, the advanced treated product water must meet the following requirements:

- Turbidity prior to disinfection shall not exceed 0.2 NTU more than 5 percent of the time within a 24-hour period and 0.5 NTU at any time.
- Chloramines concentration time shall be at least 450 milligram-minutes per liter with a modal contact time of at least 90 minutes.
- Total coliform bacteria shall not exceed a 7-day median of 2.2 Most Probable Number (MPN) per 100 mL or 23 MPN for any individual sample.
- pH must remain between 6.5 and 8.5.
- Maximum contaminant levels and maximum action levels for California Department of Public Health (CDPH) drinking water standards cannot be exceeded.
- The recycled water must not contain taste or odor-producing substances that affect the groundwater beneficial water reuse.
- The recycled water shall not cause a measurable increase in organic chemical contaminants in the groundwater.

Treatment of wastewater at TIWRP currently meets NPDES effluent limitations as outlined above. All water reuse applications involving groundwater recharge require recycled water receives treatment that achieves at least 12-log enteric virus reduction, 10-log *Giardia* cyst reduction, and 10-log *Cryptosporidium* oocyst reduction. The treatment train must also consist of at least three separate treatment processes. In addition to these pathogen removal requirements, the treatment train must also control trace organics and other constituents of emerging concern. A reverse osmosis process must be used; an oxidation process must achieve at least 0.5 log removal of 1,4-dioxane; and excessive NDMA formation must be prevented. The existing AWPf currently achieves these removal requirements.

7.1.4 Process Descriptions

In the sections that follow, descriptions are provided of TIWRP's liquid treatment processes, solids management systems, and ancillary facilities. Provided are:

- Component descriptions and design criteria
- Summary of operations
- Current performance metrics

This information provides the foundational basis for the development of future plant improvements.

7.1.5 Preliminary Treatment

The preliminary treatment process eliminates the larger-sized particles and grit from the incoming flow to protect the equipment in the subsequent processes. Preliminary treatment at TIWRP includes mechanical screening and grit removal through aerated grit basins. The preliminary treatment equipment is located in and adjacent to the TIWRP Headworks Building.

The capacity within the preliminary treatment process is 30 mgd. The various components are described below and summarized in Table 7.4.

7.1.5.1 Screening

The TIWRP Headworks Building utilizes two, 30 mgd mechanically cleaned bar screens (one duty, one standby) to remove objects such as rags, paper, plastics, and solid objects to prevent clogging and damage to downstream equipment, piping, and appurtenances. The screenings removed are hauled to a landfill for disposal.

7.1.5.2 Grit Removal

Grit removal follows screening. TIWRP utilizes two aerated grit basins that remove fine, relatively dense materials, such as sand, that were not removed by the bar screens. Removal of these materials prevents the formation of deposits in plant pipelines and minimizes abrasion in mechanical equipment further downstream in the treatment process. The grit basins are located adjacent to the Headworks Building. The aerated grit basins are equipped with chain and bucket systems; the system includes three hoppers per basin and a valve withdrawal system. The settled grit is pumped by grit pumps to the grit classifiers located in the Headworks building.

7.1.5.3 Operation

An ultrasonic flowmeter is located between the In-Plant Lift Station (IPLS) and the Headworks building. This flowmeter measures the influent flow to the headworks before screening.

The plant influent separates into two channels, one for each bar screen. The fine bar screens remove particles (>0.25 inch) while allowing the liquid stream to flow through. The screenings are dropped into a sluice into which HPE has been introduced. The suspended screenings flow to the screening presses where the excess liquid is removed. The filtrate returns to the grit chambers while the screenings are conveyed to the grit and screenings hopper.

| Table 7.4 TIWRP Preliminary Treatment Design Criteria Wastewater Facilities Plan One Water LA 2040 Plan | |
|------------------------------------------------------------------------------------------------------------------------------------------------------------|--------------------------------------------|
| Unit | Value |
| Screenings Removal | |
| Type | Mahr Continuously Raked Bar screen |
| Number | 2 (1 duty, 1 standby) (both online) |
| Capacity, each | 30 mgd |
| Bar Spacing | 0.25 in |
| Screenings Press | |
| Type | Vulcan Industrial Screw Press |
| Number | 2 |
| Capacity | 99 cfh (continuous); 33 cfh (batch) |
| Flow / Power | 19 gpm, 5 hp |
| Aerated Grit Chamber | |
| Type | Aerated |
| Number | 2 |
| Area | 10 ft x 60 ft |
| Side Water Depth | 13 ft |
| Overflow Rate (2 chambers) | 45,100 gpd/sq ft |
| Detention Time (3 chambers) | 3.14 min |
| Grit Classifiers | |
| Type | WEMCO Hydrogritter with Wemclone |
| Number / Size | 2 / 12" |
| Capacity | 220 gpm, 5 psi, 2 hp |
| Grit Pumps | |
| Type | WEMCO 4C-PMP |
| Number / Discharge Size | 2 / 4" |
| Capacity | 280 gpm @ 35 ft, 25 hp |
| Aerated Grit Chamber Blowers | |
| Type | Roots Dresser Rotary Positive Displacement |
| Number | 2 |
| Capacity | 600 scfm @ 5 psi, 20 hp |
| Screenings and Grit Hopper | |
| Capacity | 540 ft ³ |
| <i>Sources: City of Los Angeles Integrated Resource Plan, 2006, City of Los Angeles Recycled Water Master Planning Long-Term Concepts Report: Volume 2</i> | |

Grit is collected in the aerated grit chambers where it settles to the bottom of the tank. It is then pumped to grit classifiers to separate the remaining liquid from the grit. It is desirable for process optimization to keep the organic material in the liquid; air is added to the grit chamber to maintain the organic matter in suspension instead of settling with the grit. The liquid is directed to primary treatment while the grit is pumped from the grit classifiers into the grit and screenings hopper. The grit and screenings in the hopper are hauled by a dump truck to a sanitary landfill.

7.1.5.4 Current Performance

The preliminary treatment facilities are operating effectively with available unused capacity. The headworks removes approximately 5 tons per week of screenings and grit. The preliminary treatment facilities are functioning as designed but the area is subject to the release of foul air emissions from process components. The foul air from the headworks is contained to a degree, along with foul air from the primary sedimentation tanks and channels, and used as an air source by the blowers in the aeration tanks. Additional odor improvement projects, that will achieve a significant reduction in odors in the future, are being considered. This may include adding a biofilter between the emission sources and aeration tanks.

7.1.6 Primary Treatment

The primary treatment process removes the majority of settleable organic and inorganic materials that enter the plant through gravity settling in the primary clarifiers. Floatable material is eliminated by skimming the surface. The resulting primary effluent is conveyed to the aeration tanks to undergo secondary treatment. The primary treatment step significantly reduces the BOD and TSS loadings on the secondary treatment processes. A well-functioning primary treatment system also improves the quality of the biosolids produced by the plant.

TIWRP's primary treatment facilities utilize six primary clarifiers, sized at 250 feet by 20 feet, with an 11.9-foot average water depth. At average flow, the detention time in these basins is 2.14 hours with a surface overflow rate of 1,000 gpd/sq ft. Table 7.5 summarizes the existing primary treatment facilities design criteria at TIWRP.

| Table 7.5 TIWRP Primary Treatment Design Criteria Wastewater Facilities Plan One Water LA 2040 Plan | |
|--------------------------------------------------------------------------------------------------------------------|------------------------------------------------------------------------------------------|
| Unit | Value |
| Primary Clarifiers | |
| Number of Tanks | 6 (5 duty, 1 standby) |
| Surface Dimensions | 20 ft x 250 ft |
| Area | 5,000 sq ft each |
| Average Water Depth | 11.9 ft |
| Surface Overflow Rate | 1,000 gpd/sq ft |
| Detention Time | 2.14 hours |
| Capacity | 30 mgd |
| Collector Type | Brentwood Industries/Poly Chem Corp Plastic Chain and Sprockets, with Fiberglass Flights |
| <i>Source: City of Los Angeles Recycled Water Master Planning Long-Term Concepts Report</i> | |

7.1.6.1 Operation

There is a Venturi flowmeter located between the grit chambers and the primary tanks which displays the influent flow to the primaries after screening. The primary clarifier tanks employ plastic chain and sprockets with fiberglass flights to transport settled solids to the inlet hopper of each tank, while floating materials are skimmed to the opposite end. The primary clarifiers remove raw sludge, grease, and floatables from each tank to pump to the digesters for treatment. The primary effluent exits the clarifiers via submerged launders. At the end of the tanks, a concrete channel collects all the primary effluent and conveys it into the secondary treatment process.

7.1.6.2 Current Performance

The average primary effluent SS concentration was 53 mg/L reflecting a 69 percent removal efficiency, and BOD concentration was 138 mg/L reflecting a 40 percent removal efficiency (TIWRP Summary of Monthly Report data from May 2015 through April 2016). The treatment process is performing well. The automated scum removal system currently in place is not utilized and should be repaired in order to cease manual scum removal. Table 7.6 provides the performance for the primary treatment process at TIWRP.

| Table 7.6 TIWRP Primary Treatment Performance Wastewater Facilities Plan One Water LA 2040 Plan | |
|----------------------------------------------------------------------------------------------------------------|---------------|
| Description | Value |
| Average Primary Influent Flow | 15.7 mgd |
| Average Sludge Flow | 0.064 mgd |
| Average Surface Overflow Rate (SOR) | 580 gpd/sq ft |
| Peak SOR ⁽¹⁾ | 100 gpd/sq ft |
| Average BOD ₅ Removal Efficiency | 40% |
| Effluent Concentration | 138 mg/L |
| Average TSS Removal Efficiency | 69% |
| Effluent Concentration | 53 mg/L |
| Average Settleable Solids Removal Efficiency | 99% |
| <i>Source: Monthly Performance Reports July 2014 to June 2015, TIWRP engineering staff.</i> | |
| <u>Note:</u> | |
| (1) Based on 1000 gpd/sq ft. | |

Table 7.6 shows that the primary treatment process is operating at about half its design capacity on average. As a result, if the plant sees an increase in influent flows, the primary process train will be able to handle it.

7.1.7 Secondary Treatment

The purpose of secondary treatment is to remove soluble BOD that is not removed by primary treatment and provide further removal of suspended solids. Oxygen is provided using a fine bubble aeration system in open tanks. The process is configured to also remove nitrogen to a degree by ammonia nitrification and nitrate denitrification.

7.1.7.1 Aeration Tanks

Wastewater undergoes biological treatment in the aeration tanks. In the aeration tanks, air is introduced into the wastewater to allow for the dissolution of oxygen into the liquid and thereby promote the growth of microorganisms that feed on organic materials in the sewage. At the end of each tank, the effluent is collected and gravity flows into clarifiers. The aeration tanks employ biological nitrogen removal through nitrification and then denitrification. In nitrification, organic-N compounds and NH₃-N are converted to nitrite (NO₂-N) and then to nitrate (NO₃-N). In denitrification, the nitrate is converted to nitrogen gas, which is released to the atmosphere. This process requires an anoxic (absent of oxygen) environment and an organic carbon source.

7.1.7.2 Process Air System

Process air is provided by up to three blowers. The blowers, situated north of the primaries in the compressor room, take odorous air from the headworks, the primary clarifiers, and the primary effluent channels of the primary clarifiers to supply the aeration demand in the aeration tanks. Air is delivered through headers and downcomer pipes to each grid of fine-bubble diffusers in order to feed the microorganisms in the activated sludge.

7.1.7.3 Secondary Clarifiers

Wastewater undergoing biological treatment in the aeration basins flows to the clarifiers. The secondary clarifiers provide a quiescent zone for gravity separation of the activated sludge from the clarified effluent. The suspended heavy materials settle to the bottom of the clarifiers as sludge.

7.1.7.4 Design Criteria

The TIWRP has nine rectangular aeration tanks, 30 feet by 300 feet, with a 15-foot sidewater depth. The TIWRP aeration tanks are equipped with fine-bubble diffusers. Since the TIWRP receives a significant proportion of its influent from industrial facilities, staff operates the aeration tanks to provide nitrification. In order to better control the air flow into each tank, the process air piping was redesigned in 2016 to allow one pipeline feeding air per tank instead of sharing between tanks. TIWRP has a total of 18 secondary clarifiers, which are 150 feet by 20 feet, with a 12-foot sidewater depth. The clarifiers are divided into two batteries of 9 tanks each, arranged so that the effluent is discharged into a common channel between the two batteries. One of the basins is converted for use as an emergency bypass. Table 7.7 presents the design criteria for the secondary treatment equipment at TIWRP.

| Table 7.7 TIWRP Secondary Treatment Design Criteria Wastewater Facilities Plan One Water LA 2040 Plan | |
|--------------------------------------------------------------------------------------------------------------------------------------------------|----------------------------------------------------------|
| Unit | Value |
| Aeration Tanks | |
| Type | Conventional, 1 pass |
| Number | 9 |
| Area, each | 30 ft x 300 ft |
| Average Water Depth | 15 ft |
| Hydraulic Detention Time | 6 hours |
| Design Capacity (Avg) | 30 mgd |
| DO Level | 1-2 mg/L |
| Air Requirement | 1,500 cfm/lb BOD |
| Process Air Blowers | |
| Type | High Efficiency, Centrifugal Siemens Turbocompressors |
| Number | 3 (1 duty, 2 standby) |
| Capacity, large | 1,750 hp, (1) 35,000 scfm at 9.0 psig; |
| Capacity, small | 1,500 hp, (2) 27,000 scfm @ 9.0 psig |
| Secondary Clarifiers | |
| Number | 18 |
| Area | 20 ft x 150 ft |
| Average Water Depth | 12 ft |
| Overflow Rate | 555 gpd/sq ft |
| Detention Time | 2.9 hours |
| Design Capacity (Avg) | 30 mgd |
| Rotating skimmers and electric actuators | 36 |
| No. of skimmers per tank | 2 |
| No. of gate valves per clarifier | 3 |
| Size of gate valves | 8" |
| RAS Pumps | |
| Type | Johnson Company Variable Speed Vertical Centrifugal |
| Number | 3 (1 Duty + 2 Standby) |
| Capacity (Each) | 20,000 gpm, 27-ft-head, 200 hp |
| <i>Sources: City of Los Angeles Integrated Resource Plan, 2006, City of Los Angeles Recycled Water Master Planning Long-Term Concepts Report</i> | |
| <u>Abbreviation:</u> | |
| cfm/lb = cubic feet per minute per pound | |

7.1.7.5 Operation

The primary effluent flows from the primary clarifiers into the secondary aeration tanks. The original design of the aeration process allowed for plug flow, step feed, or serpentine flow; however, the current operation of the aeration basins for nitrification and denitrification is only supported by the plug flow arrangement. In order for denitrification to be successful, proper mixing is required. The first zone is an anoxic selector zone without mixing. Mixing is not required due to the influent flow turbulence and introduction of RAS. The flow continues into a denitrification zone, swing zone, and nitrification zone with a return line. Table 7.8 summarizes the function at each zone in the aeration basins.

| Table 7.8 TIWRP Aeration Basin Grids Wastewater Facilities Plan One Water LA 2040 Plan | | |
|-------------------------------------------------------------------------------------------------------|--------------------------|-------------------------------------------------------------------------------------------------------------------------------------------------------------------------------------------------------------------------------------------------|
| Zone | Function | Description |
| 1 | Anaerobic | Zone 1 is the selector zone to limit filament growth while mixing primary effluent and RAS. |
| 2 | Anoxic | Zone 2 is the first zone for denitrification. This is where the recycle line from the end of the aerobic zone enters. Zone is characterized by a high concentration of nitrate, very little to no oxygen, and incoming BOD and RAS from Zone 1. |
| 3 | Anoxic / denitrification | Zone 3 is operated the same as Zone 2. It continues denitrification and allows operators a degree of control over the sludge volume index (SVI). |
| 4 | Swing | Zone 4 has rubber membrane air diffusers to allow zone to be either aerated or anoxic depending on whether more time is needed for denitrification or nitrification. |
| 5 | Aerobic | Zone 5 introduces oxygen and nitrification cycle begins. |
| 6 | Aerobic | Zone 6 is aerobic and continues nitrification using ceramic fine-bubble disc diffusers. |
| 7 | Aerobic | Zone 7 is aerobic and uses ceramic fine-bubble disc diffusers. The nitrification and BOD reduction are mostly completed. The maximum dissolved oxygen concentration in Zone 7 is 3.0 mg/L. |
| <i>Source: TIWRP Plant Engineering Staff</i> | | |

RAS is mixed in with the primary effluent at the north end of the tank and is controlled to a ratio of the aeration tank's influent flow, typically set at 80 – 100 percent depending on treatment. The RAS can also be chlorinated periodically when there is an overgrowth of filaments.

The secondary clarifiers are arranged with their sludge hoppers at the effluent end, beneath the effluent weirs. Each tank has two hoppers, with a control valve for each tank. Three (1 duty, 2 standby) variable speed vertical centrifugal pumps withdraw RAS from the wet well and pump it back to the influent end of the aeration basins.

Currently, the plant operates with one duty and two standby blowers. The blowers are controlled by a master control panel (MCP) to regulate all three blower compressors at once, allowing for ease in turning down and bringing blowers online. The plant is being converted to the Honeywell Distributed Control System to control the aeration distribution system based on dissolved oxygen in the aeration tanks. Each aeration tank has its own header in order to properly control the air flow requirements in each basin. With the installation of a stainless steel sluice gate (60 inches by 72 inches) at the end of the aeration basins, the level of the aeration basins is controlled by the height of the sluice gate.

7.1.7.6 Emission Control Process

The blowers at TIWRP use foul air collected from the headworks, primary sedimentation tanks and channels. Because foul air from these sources typically contain hydrogen sulfide and other odorous VOC's, utilizing this source for aeration is permitted by the Air Quality Management District. Aeration tanks with fine bubble aeration diffusers provide the odor removal by absorption, condensation, and microbial oxidation resulting in lower VOC's emissions for TIWRP. This system is considered effective in treating moderate to high strength odors. Similar systems have been in operation for 40 years, and more than 25 facilities have used this technology. Additional odor improvement projects, that will achieve a significant reduction in odors in the future, are currently being considered to be added as additional step in series, including adding a biofilter between the emission source and aeration tanks.

7.1.7.7 Current Performance

The aeration tanks were running with 6 units online during the period from May 2015 to April 2016. Table 7.9 summarizes the performance for the secondary treatment process at TIWRP.

| Table 7.9 TIWRP Secondary Treatment Performance Wastewater Facilities Plan One Water LA 2040 Plan | |
|--------------------------------------------------------------------------------------------------------------------------------------------|--------------|
| Description | Value |
| Number of Aeration Tanks in Service | 6 (9 Total) |
| TSS Removal | |
| Efficiency | 87% |
| Effluent Concentration | 5 mg/L |
| BOD Removal | |
| Efficiency | 95% |
| Effluent Concentration | < 5 mg/L |
| pH | 7.7 |
| F/M Ratio | 0.37 lb/lb |
| Average MLSS | 2023 mg/L |
| Effluent Settleable Solids | <0.1 ml/l |
| Average Mean Cell Residence Time | 8.64 days |
| Average Sludge Volume Index (SVI) | 131.25 |
| Average DO | 6.95 mg/L |
| <i>Sources: Monthly Performance Report from May 2016, Monthly Performance Reports from May 2015 to April 2016, TIWRP engineering staff</i> | |

The plant was utilizing 6 out of 9 total aeration tanks which is under capacity but more consistent with the influent flows seen during the reporting timeline. The secondary treatment process has no operational issues.

7.1.8 Tertiary Treatment

TIWRP tertiary treatment process uses gravity flow filters with deep mono-media beds consisting of coarse sand. The Tetra Denite system produced by Severn Trent Services designed to remove suspended solids as well as nitrate from the secondary effluent resulting in a reduction of settleable solids, suspended solids, and turbidity in the wastewater effluent. A backwash system is used to remove the trapped particles in the filters. The backwash is discharged into the primary clarifiers or secondary influent. The clarified liquid stream that is produced is discharged into the Phase I and Phase II AWWPF for further treatment.

TIWRP has 16 mono-media deep filter beds. The target plant capacity for average flow is 30 mgd while the peak hour flow is 55 mgd for dry weather and 66 mgd for wet weather. Due to this design capacity, the maximum loading rate is 5 gpm/sq ft and the average flow rate is 2.3 gpm/sq ft. Table 7.10 summarizes the design criteria for the tertiary filters.

| Table 7.10 TIWRP Tertiary Treatment Design Criteria Wastewater Facilities Plan One Water LA 2040 Plan | |
|----------------------------------------------------------------------------------------------------------------------|----------------------------------------------|
| Unit | Value |
| Filtration System | |
| Type | Mono-denitrifying Deep Filter Beds |
| Number | 16 |
| Size | 60 ft x 10 ft |
| Design Capacity, ADWF | 30 mgd |
| Design Capacity, Peak Hour | 55 mgd (dry weather) 66 mgd (wet weather) |
| Average Flowrate | 30 mgd |
| Influent Water Quality | |
| Nitrate | 5.4 to 11 mg/L as N |
| Turbidity | 0.65 to 10 NTU |
| Total Suspended Solids | 2.5 to 38 mg/L |
| Media Configuration | |
| Media Type | TETRA #5 Sand |
| Specific Gravity | 2.65 |
| Effective Size | 2 to 3 mm |
| Uniformity | 1.4 |
| Bed Depth | 72 in |
| Underdrain | TETRA T-Block |
| Support Media Type | Gravel |
| Support Media Depth | 18 in |
| Filtration Cycle | |
| Hydraulic Loading Rate | 3 to 5 gpm/sf |
| Nitrate Loading Rate | 1.0 to 1.8 kg N/m ³ -day |
| Solids Capacity | 2.67 kg TSS/m ³ |
| Minimum Water Level | 15 ft AMSL |
| Clean Bed Headloss | 0.2 to 0.3 ft |
| Terminal Headloss | 14.4 to 16.3 ft |
| Backwash Cycle | |
| Backwash Frequency | Max 5 days per filter |
| Backwash Water Flux | 5 to 6 gpm/sf |
| Backwash Supply | 4.3 to 5.2 mgd |
| Bed Headloss | 0.3 to 32.6 ft |
| Bed Expansion | 0% |
| Air Scour Flux | 3 to 5 icfm/sf |
| Air Scour Rate | 1,800 to 3,000 icfm |
| Air Scour Back Pressure | 9.1 psi |

| Table 7.10 TIWRP Tertiary Treatment Design Criteria Wastewater Facilities Plan One Water LA 2040 Plan | |
|-------------------------------------------------------------------------------------------------------------------------------------------------------------------------------------------------------------------------------------------------------|-----------------------------------------------------------|
| Mechanical Equipment | |
| Backwash Supply Pumps | |
| Type | Floway Vertical Turbine |
| Number | 3 |
| Flow | 5.2 mgd |
| Head | 76 ft |
| Air Scour Blowers | |
| Type | Robuschi USA, Inc-Blower Company Positive Displacement |
| Number | 2 |
| Flow | 3600 scfm |
| Head | 9.1 psi |
| <i>Sources: City of Los Angeles Integrated Resource Plan, 2006, City of Los Angeles Recycled Water Master Planning Long-Term Concepts Report, TIWRP Tertiary Filter Rehabilitation Final Preliminary Design Report (CIP 5229) October 2013 (MWH).</i> | |
| <u>Note:</u> | |
| (1) Tertiary treatment design criteria includes CIP 5229 information. | |

7.1.8.1 Operation

The operation of the filters depends on effective execution of the filtration cycle and the backwash cycle, explained below.

Filtration Cycle – The filters are operated with filtration and backwash. During the filtration cycle, water flows through the filters by gravity in a downward direction. Suspended solids are removed by depth filtration, and when a carbon source is fed upstream of the filters, nitrate is reduced to nitrogen gas by an attached-growth denitrification process. Headloss through the filter bed increases as suspended solids are entrained and biomass grows in the void volume of the media bed. This causes the water level in the filter cell to rise.

Backwash Cycle – Compared to other granular media filters, denitrifying filters are backwashed at a lower velocity over a longer period of time. This backwash strategy removes solids that have accumulated in the filter, and also sloughs off some biomass without removing an excessive amount (since the design is to permit denitrification via the biofilm growing on the media). Backwash consists of pumping water to flush the filter in the upflow direction, along with air scour.

If the filters are operated mainly for suspended solids removal, they will be backwashed either when turbidity breakthrough is observed in the effluent, or when the water level in the filter box has risen to its highest point, a head of 20 feet. This latter point is referred to as the terminal headloss. If the filters are operated for denitrification, the time between backwashes is often set by the desire to maintain a healthy growth rate in the biofilm, and

backwash will often be done at regular intervals regardless of whether the terminal headloss has been reached. However, with high-turbidity influent, backwash may be required after a shorter time.

7.1.8.2 Current Performance

The filter effluent data for the upgraded filters is not yet available. The following performance data, shown in Table 7.11, is from May 2015 through April 2016, before the upgraded filters came online. The upgraded filters' manufacturer product data indicates that <5 mg/L TSS is achievable and <2 mg/L is typical. Nitrogen management is important at the system level for a variety of reasons. Nitrification followed by denitrification manages the overall nitrogen load and is required to meet nitrogen and nitrate limits in the finished water. In addition, nitrification of ammonia helps control precursors to NDMA formation, and the NdN process is beneficial to reduce fouling on downstream membranes.

| Table 7.11 TIWRP Tertiary Quality and Limits Wastewater Facilities Plan One Water LA 2040 Plan | | | |
|---------------------------------------------------------------------------------------------------------------|-------------|--------------------------|--------------|
| Parameter | Unit | Tertiary Effluent | Limit |
| Effluent Flow | mgd | 15.3 | -- |
| Chlorine Residual | mg/L | 0.01 | 0.1 |
| Total Suspended Solids | mg/L | 2.2 | 15 |
| BOD | mg/L | 0.01 | 15 |
| Turbidity | NTU | 1.2 | 2 |
| Ammonia (as N) | mg/L | 1.6 | 7.4 |
| TSS Percent Removal | % | 98.7 | -- |
| BOD Percent Removal | % | 99.1 | -- |
| <i>Source: LASAN TIWRP Summary of Monthly Report data from May 2015 through April 2016</i> | | | |

As Table 7.11 shows, TIWRP was meeting all effluent quality limits before the filter upgrade and should continue to do so after the upgrade.

7.1.9 Advanced Water Purification Facility

The advanced treatment process removes any remaining suspended and colloidal particles that have passed through the filtration system. Also removed are salts, minerals, metal ions, organic compounds, and microorganisms. Constituents removed by the membranes are concentrated in the reject stream to be discharged through the brine line to the Los Angeles Harbor or combined with the digested biosolids being injected in the TIRE facility. The advanced treatment processes produce a high quality product water that is used for recharging coastal barrier wells, landscape irrigation, boiler water, cooling water, and replacing evaporation losses for Lake Machado.

Phase I of the AWPf was completed in and has been in operation since 2006. The original process train consisted of 6 mgd of MF, RO, and disinfection processes. Phase II of the system came online in early 2017 doubling the current system capacity to 12 mgd and upgrading TIWRP to FAT with the addition of a UV-AOP system. The main goal for the upgrade was to increase the amount of recycled water produced by TIWRP. The AWPf expansion project included additional MF, RO, and advanced oxidation process (AOP) systems and corresponding upgrades to existing pumping stations and support systems, chemical addition system, auxiliary systems and utilities. The AOP System using ultraviolet irradiation/sodium hypochlorite (UV/NaOCl) will also replace existing Phase 1 disinfection system. To operate AWPf at a constant flow and maximize production, project also includes 2.0 MG tertiary effluent equalization tank, upstream of the AWPf.

7.1.9.1 Pilot Testing – AOP Selection

Extensive bench scale tests were performed by LASAN as an early-stage tool for assessing candidate AOPs. These bench scale tests also served as a predictor of pilot performance for the TIWRP AWPf water matrices. Bench work included testing of various doses for O₃/H₂O₂, UV/NaOCl, and UV/H₂O₂ to determine the required dosage to meet the 2014 DDW draft Groundwater Recharge Reuse Regulations (GRRR), specifically looking at removal of 1,4-dioxane, NDMA, constituents of emerging concern (CECs), other disinfection byproducts (DBPs), and the cumulative pathogenic inactivation for the AWPf train. All five AOP systems that were selected for bench scale testing performed satisfactorily, meeting both the CECs' removal and disinfection goals; however, not all tests achieved the required removal of 1,4-dioxane (0.5-log) and NDMA notification level (10 nanograms per liter [ng/L]). The bench scale testing established the initial AOP system design criteria, and the pilot served to confirm and enhance the design of the selected process.

7.1.9.2 Full-Scale design

Phase II is essentially a duplication of the optimized Phase I MF/RO treatment process with the addition of AOP. To dampen diurnal flow variation, there is a 2 MG tertiary effluent equalization tank upstream of the AWPf. The product water pump station is located downstream of the chlorine contact tank. This pump station distributes the final product water to the end users. The pumping facilities were designed during the AWPf Phase I to meet the Phase II expansion requirements. A process flow diagram of the AWPf is shown on Figure 7.4.

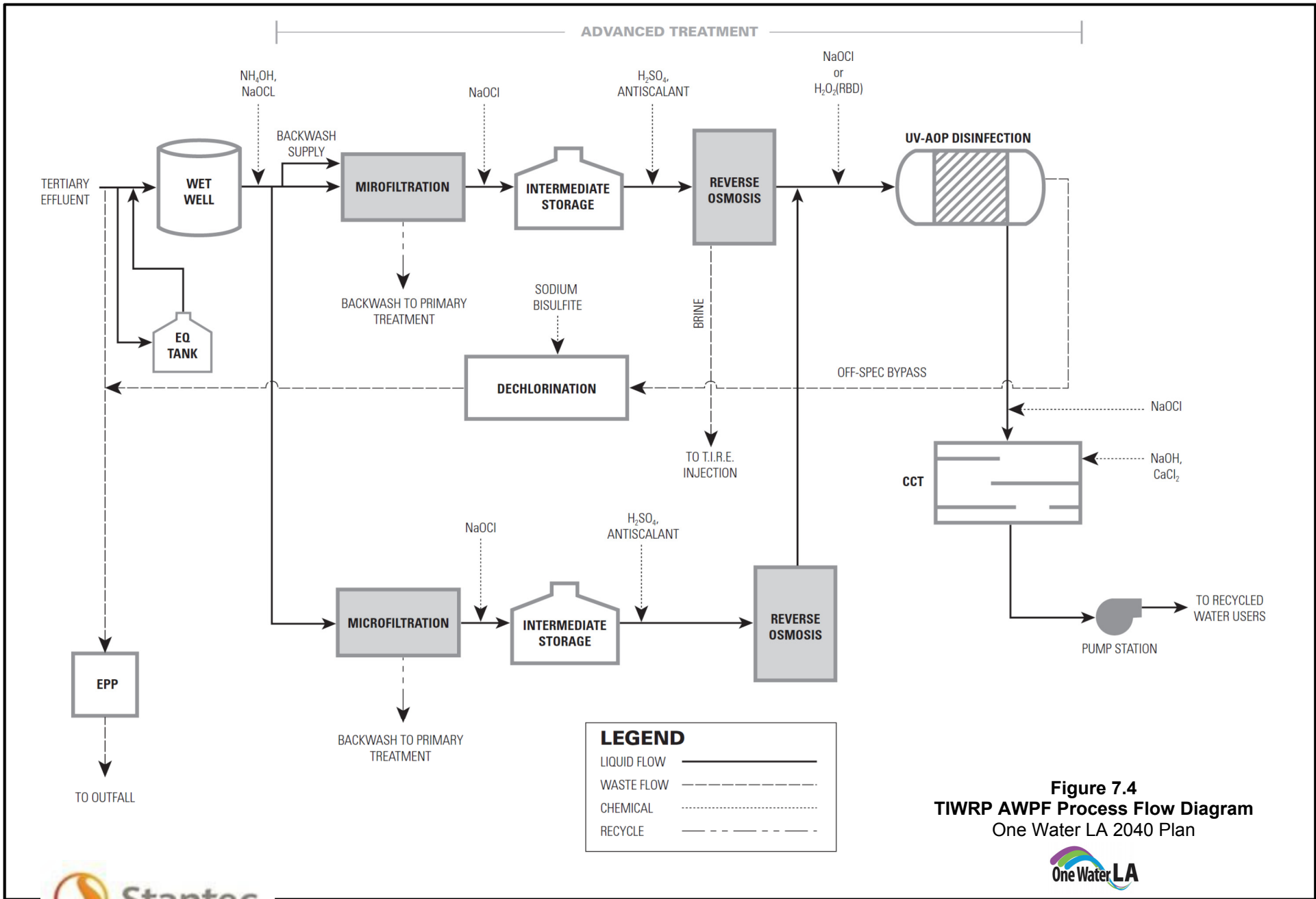

Figure 7.4
TIWRP AWP Process Flow Diagram
 One Water LA 2040 Plan

As previously discussed, Phase I construction of TIWRP's AWPf was completed in 2002 and has been online since 2006. Phase II Expansion was completed and came online in the first quarter of 2017. Table 7.12 shows the design criteria for Phase I and the Phase II Expansion for the TIWRP AWPf.

| Table 7.12 TIWRP Advanced Treatment Facilities Design Criteria Wastewater Facilities Plan One Water LA 2040 Plan | | |
|---------------------------------------------------------------------------------------------------------------------------------|-------------------------------------------------------|----------------------------------------------|
| Unit | Phase I | Phase I & II |
| Chemicals added to tertiary effluent | NH ₃ (aq), NaOCl | – |
| Equalization Tank | | |
| Capacity | – | 2 MG |
| MF Feed Pump Station | | |
| Pumps | 3 (2 duty, 1 standby) | 5 (4 duty, 1 standby) |
| Manufacturer | Goulds Pumps | Goulds Pumps |
| Head | 35 psi | 35 psi |
| Chemicals Added | NH ₄ OH, NaOCl | |
| Microfiltration | | |
| Feed Water Microscreens | 500 µm | 500 µm |
| Feed Pressure | 35 psi | 35 psi |
| Pretreatment | Sodium Hypochlorite and Ammonia Addition | Sodium Hypochlorite and Ammonia Addition |
| Number of Installed Units | 12 (2 trains) | 16 (6 new units) |
| Model/Type | Evoqua Memcor® 90M10C/Hollow Fine Fiber/Polypropylene | Evoqua Memcor® CP240w/Hollow Fine Fiber/PVDF |
| Feed Water, Total Capacity | 5,800 gpm ⁽¹⁾ | 5,785 gpm |
| Filtrate Water, Total Capacity | 5,336 gpm ⁽¹⁾ | 5,380 gpm |
| Chemical Added | NaOCl | NaOCl |
| RO Feedwater Pumps | | |
| Type | Afton Vertical Turbine Pumps | Afton Vertical Turbine Pumps |
| Number | 2 | 4 |
| Design Flow Capacity (Each) | 2,600 gpm | 2,600 gpm |
| Design TDH | 578 ft | 578 ft |
| Chemical Added | H ₂ SO ₄ , antiscalant | H ₂ SO ₄ , antiscalant |

| Table 7.12 TIWRP Advanced Treatment Facilities Design Criteria Wastewater Facilities Plan One Water LA 2040 Plan | | |
|---------------------------------------------------------------------------------------------------------------------------------|---------------------------------|---------------------------------|
| Unit | Phase I | Phase I & II |
| RO Booster Pumps | | |
| Type | Peerless Horizontal End Suction | Peerless Horizontal End Suction |
| Number | 3 | 3 |
| Capacity | 2,600 gpm, 125 hp | 2,600 gpm, 125 hp |
| RO Second Stage Booster Pumps | | |
| Type | Afton Vertical Turbine | Afton Vertical Turbine |
| Number | 2 (one per train) | 4 (one per train) |
| Design Flow Capacity (Each) | 878 gpm, 75 hp | 878 gpm, 75 hp |
| Design TDH | 230 ft | 230 ft |
| Reverse Osmosis | | |
| Feed Water, Total Capacity | 5,380 gpm | 10,760 gpm |
| Permeate, Total Capacity | 4,300 gpm | 8,600 gpm |
| Permeate, Per Train | 1,076 gpm | 1,076 gpm |
| Number of RO Trains | 2 (2 stages, each) | 4 (2 stages, each) |
| Nominal Permeate Capacity per Train | 3 mgd | 3 mgd |
| Number of vessels per Train | 98 | 98 |
| Number of membrane elements per Vessel | 7 | 7 |
| Number of elements per Train | 686 | 686 |
| Type | Polyamide | Polyamide |
| Model No. | Hydranautics ESPA-2 MAX | Hydranautics ESPA-2 MAX |
| Chemicals Added | Lime | NaOCl |
| RO Design Performance Criteria | | |
| Maximum RO System Permeate Capacity (Design) | 6.0 mgd | 12.0 mgd |
| Range of Permeate Capacity per Train (Design) | 2.0 – 3.0 mgd | 2.0 – 3.0 mgd |
| Water Flux at Nominal Capacity (Design) | 10 gfd | 10 gfd |
| RO Recovery (Design) | 80 – 85% | 80 – 85% |
| UV/AOP | | |
| Model/Type | -- | Wedeco/K143 12/17x2 |
| Product Water, Total Capacity | -- | 12 mgd (100% redundancy) |
| Chemical Added | -- | NaOCl |

| Table 7.12 TIWRP Advanced Treatment Facilities Design Criteria Wastewater Facilities Plan One Water LA 2040 Plan | | |
|---------------------------------------------------------------------------------------------------------------------------------|-------------------------------------------------|------------------------------|
| Unit | Phase I | Phase I & II |
| Post Treatment | | |
| Chlorine Contact Tank Volume | 640,000 gallons | 640,000 gallons |
| Product Water Total Chlorine Residual Required at 5.0 mgd product water flow | 2-3 mg/L | 2-3 mg/L |
| Chemical Addition | NaOCl, NH ₃ (aq), NaHSO ₃ | NaOH, CaCl ₂ |
| Product Water Pump Station | | |
| Number of Installed Pumps | 3 (2 duty + 1 standby) | 6 (4 duty + 2 standby) |
| Pump Type | Goulds Vertical Turbine, VFD | Goulds Vertical Turbine, VFD |
| Design Flowrate, per pump | 2,100 gpm | 2,100 gpm |
| Maximum Capacity, per pump | 2,600 gpm | 2,600 gpm |
| <i>Source: Amended Engineering Report for the TIWRP AWP Expansion: Dominguez Gap Barrier Project (August 2015)</i> | | |
| Abbreviations: | | |
| µm = micrometer, gfd = gallons per square foot per day | | |

7.1.9.3 Operation

Tertiary filter effluent flows into the MF feedwater wetwell. During high flow, excess water will be pumped into the Equalization Tank. During low flow, the stored tertiary effluent will gravity flow from the Equalization tank into the MF feedwater wetwell. Pumps feed MF trains A & B, and the recently completed train C through two independent manifolds. The MF system provides pretreatment for the RO feedwater by removing particles greater than 0.1 µm. Following MF, filtrate flows into two RO feedwater tanks, which supply dedicated RO trains: A & B and C & D. The feedwater flows through RO trains which produces to process streams - the RO permeate and the RO brine. The RO filters remove particles down to 0.0001 µm as well as achieving a two-log removal credit for viruses, and significant reductions in metal ions and salts. Sulfuric acid and a scale inhibitor are added in the RO feedwater line to reduce fouling in the RO filters. Some of the permeate is pumped to the MF CIP tanks for the MF CIP system, the RO CIP tank for the RO CIP system, and the RO flush tank for flushing the RO membranes. The majority of the permeate is delivered to the Dominguez Gap Barrier (DGB) for injection into the seawater intrusion barrier. To stabilize the product water and meet the Langelier Saturation Index requirements, calcium chloride and sodium hydroxide are added in the chlorine contact tank.

7.1.9.4 Current Performance

The Phase I AWPf has experienced a number of operational issues since 2002. These issues have been the subject of several studies to evaluate the condition of the AWPf and analyses to improve its reliability.

It has been a challenge to balance the Langelier Saturation Index (LSI) with the Modified Fouling Index, a measure of the propensity of the water to plug the pores of membranes, but used in this case on finished water to assess the injection wells clogging potential. Recommendations to improve the Phase I RO process include: replacing PVC concentrate valves with higher pressure rating valves; performing an "audit" to assess the condition of all seals; replacing gaskets in interstage flowmeters/repairing interstage flowmeters; recording feedwater temperature (affects membrane fouling/scale); and developing a calibration schedule for chemical feed pumps and chemical feed instrumentation.

The Phase I MF membranes are the flow-limiting factor in the AWPf process. Recommended upgrades to the MF membranes include replacing the backwash valves, replacing selected O-rings, increasing frequency of low-pH chemical cleanings to remove inorganic constituents, and avoiding re-use of chemical cleaning solutions.

7.1.10 Effluent Discharge System

The original effluent disposal system discharges TIWRP's treated wastewater effluent into the Los Angeles Harbor. The system consists of a centrifugal pump system and a 48-inch pipeline that connects to a 60-inch outfall that terminates in the Los Angeles Harbor. The plant's discharge into the harbor is by gravity flow at low flow and/or low tides and is pumped at higher flows/higher tide conditions.

In 2006, the TIWRP plant effluent began to discharge the AWPf effluent into the DGB. The Barrier is a 4.3-mile-long seawater intrusion barrier near the coast between the Los Angeles Harbor and Long Beach Harbor. The Barrier is the largest end user of the purified recycled water produced at TIWRP.

Table 7.13 summarizes the design criteria for the effluent discharge facility at TIWRP.

7.1.10.1 Operation

The average daily outfall discharge of conventional undisinfected tertiary effluent was approximately 15.9 mgd, not including brine disposal and advanced treated product water discharged to the outfall.

| Table 7.13 TIWRP Design Criteria – Effluent Discharge Facility Wastewater Facilities Plan One Water LA 2040 Plan | |
|-----------------------------------------------------------------------------------------------------------------------------------------------------------------------------------------------------------------------------------------------|----------------------------------------------------------------------------|
| Unit | Value |
| Effluent Pumps | |
| Type | Allis Chambers Rotary Pumps (centrifugal, variable speed) |
| Number | 3 (1 duty, 2 standby) |
| Capacity | Pump 1: 21,000 gpm/17.3-ft.-head, Pumps 2 and 3: 35,000 gpm/48-ft.-head |
| Ocean Outfall | |
| Pipe Size | 48 in., 60 in., and 72 in. |
| Length | 5,875 ft |
| Capacity (Peak wet weather flow)) | 66 mgd |
| Elevation | -35.00 ft MLLW ⁽¹⁾ |
| <u>Note:</u> (1) MLLW refers to the United States' National Oceanic and Atmospheric Administration's mean lower low water, which is the average height of the lowest tide recorded at a tide station each day during the recording period. | |

7.1.10.2 Current Performance

The effluent discharge system is functioning as designed. For the overall plant, the final effluent quality is well below the limit requirements. The final effluent quality and final effluent limits for 2015 are shown in Table 7.2 in Section 7.1.3.

7.1.11 **Solids Processing**

The solids handling facilities treat the sludge collected from the primary clarifiers and the secondary clarifiers prior to reuse. This process involves the following sequential stages: thickening, stabilization, dewatering, and reuse. The facilities consist of a dissolved air flotation thickeners, sludge blending tank, anaerobic digesters, and dewatering centrifuges. A detailed discussion of the strategy for biosolids management at TIWRP is summarized in Chapter 9 "Biosolids Management".

7.1.11.1 Solids Quality

The biosolids from TIWRP are regularly tested for fecal coliforms and salmonella, as indicator species for pathogens. The biosolids from the thermophilic digestion process meet both standards for Class A biosolids, with fecal coliforms <1000 MPN per dry gram of solids, and salmonella <3 MPN per 4 dry grams of solids. The biosolids are also tested for helminth ova and enteric viruses, and consistently are below the limit of 1 unit per 4 dry grams.

7.1.11.2 Solids Reuse

Broadly, there are two approaches to reuse of the residual, digested solids from TIWRP. The majority of biosolids are currently directed to TIRE for reuse. The plant also retains the capabilities to dewater the biosolids and transport materials to different locations for agricultural use to condition soils or produce compost.

7.1.11.3 Terminal Island Renewable Energy (TIRE)

The TIRE project is the first of its kind demonstration project using deep placement of digested sludge 6,000 feet below sea level in a depleted oil formation that serves as an end disposal method. It is also intended to produce methane in the future. This gas production will be as a result of the injection and associated geothermal biodegradation. The digested sludge is injected at a rate of up to 330 gpm using high-pressure progressive cavity pumps located in a 0.5-acre area at the northwest corner of the TIWRP site. The demonstration permit is valid until December 2018; the direction of the project will be decided before then.

7.1.11.4 Offsite Reuse Option

Prior to the use of TIRE, the plant dewatered biosolids and land applied these material to agricultural property in Maricopa County in Arizona. TIWRP has maintained the physical and institutional capabilities to resume this practice.

7.1.11.5 Design Criteria

The capacity of the solids handling facilities is based on the Design Criteria presented in the *Concept Report Terminal Island Treatment Plan Solids Handling Facility Upgrade*, City of Los Angeles, 1992. The quantity of dewatered sludge dry solids is based on the design criteria in Table 7.14. The resulting quantity of dewatered sludge dry solids is 35,700 lbs/day or approximately 19 dry tons per day (dtpd). Table 7.14 lists the design criteria for the solids handling facility at TIWRP.

| Table 7.14 TIWRP Solids Handling Facility Design Criteria Wastewater Facilities Plan One Water LA 2040 Plan | |
|--------------------------------------------------------------------------------------------------------------------------------------------------|-----------------------------------------------|
| Unit | Value |
| Digested Sludge Flow | 180 gpm |
| Digested Sludge Total Solids | 2% |
| Digested Sludge Dry Solids | 50,467 lbs/day |
| Dewatered Sludge Total Solids | 22-26% |
| WAS Thickener | |
| Type | Westec Circular Dissolved Air Floatation Tank |
| Number of Tanks | 1 |
| Capacity | 183,000 gallons |
| Loading Rate | 1.27 lbs/hr/sq ft |
| Sludge Thickener Pumps | |
| Number | 2 |
| Capacity | 500 gpm |
| Horsepower | 25 hp |
| Sludge Storage Blending Tank | |
| Type | Circular, steel tank with plastic liner |
| Number of Tanks | 1 |
| Diameter | 40 ft |
| Side Water Depth | 15 ft |
| Capacity | 140,995 gallons |
| Solids Loading Rate | 74.5 lbs/sq ft/d |
| Sludge Storage Time | 13 hrs |
| Sludge Blending Pumps | |
| Type | Centrifugal |
| Number | 2 |
| Capacity | 500 gpm |
| Horsepower | 75 hp |
| Anaerobic Digesters | |
| Type | Egg Shaped Anaerobic Digesters |
| Number | 4 |
| Hydraulic Capacity | 1.38 MG |
| Hydraulic Detention Time | 15 days |
| Sludge Dewatering | |
| Type | Andritz (3)/Sharples (1) Centrifuges |
| Number | 4 |
| Capacity | 2@90 gpm, 1@250 gpm |
| % Solids in Wetcake | 2@22%, 1@25% |
| <i>Sources: City of Los Angeles Integrated Resource Plan, 2006, City of Los Angeles Recycled Water Master Planning Long-Term Concepts Report</i> | |
| <i>Abbreviations:</i> | |
| lbs/hr/sq ft = pounds per hour per square foot, lb/sq ft/d = pounds per square foot per day | |

7.1.11.6 Operation

The WAS is pumped from the RAS wetwell to the DAF tank. The DAF tank thickens the sludge to approximately 3 to 5 percent. The supernatant removed from the DAF tank flows to the In-Plant Lift Station to be pumped to the headworks for treatment. The DAF has dedicated thickened waste activated sludge (TWAS) feed piping that conveys the TWAS directly to the digesters or alternatively TWAS can be conveyed to the blending tank for mixing with primary sludge prior to being fed to the digesters. Ferrous chloride is added to the sludge prior to anaerobic digestion to reduce the formation of hydrogen sulfide gas. The total solids in the digested sludge is 2.3 percent. The digested solids can be further processed through centrifuges for dewatering. Cationic polymer is injected into the centrifuges to aid in dewatering. Total solids in the dewatered sludge is typically around 22 percent. The liquid centrate is pumped to the in-plant sewer line to be recycled to the headworks and treated. The digester gas is fed to the boiler to produce steam for digester heating.

7.1.11.7 TIRE

The TIRE project currently takes 100 percent of the digested sludge produced by the TIWRP solids processing system. Between 50 to 175 wet-tons per day of dewatered biosolids from HWRP are also added to, and blended with, TIWRP biosolids and injected. In this demonstration phase, TIRE is not producing any methane. The centrifuges are not used in connection with the injection operations since a liquid medium is required for a successful injection. A small portion of the brine is used to flush the injection wells before and after pumping.

7.1.11.8 Current Performance

The June 2014 Monthly Report reported an average of 134,000 gpd of blended sludge (2.8 percent total solids) processed through the digesters with a 27-day average detention time. Total solids destruction was 45 percent and volatile solids destruction was 38 percent. For the alternative deep well injection of Class A-compliant digested sludge, about 966 wet tons (3.6 MG) were sent to the TIRE site for deep well injection at a depth of 6,000 feet in June 2014. Table 7.15 presents the solids handling performance at TIWRP.

| Table 7.15 TIWRP Solids Handling Performance Wastewater Facilities Plan One Water LA 2040 Plan | |
|-------------------------------------------------------------------------------------------------------------------------------------|--------------------|
| Description | Value |
| Blended Digester Feed | |
| Average Total Flow | 115 Kgal/day |
| Average Total Loading | 29849 lbs/day |
| Digesters in Service | 3 |
| Digested Sludge | |
| Average Detention Time | 31 days |
| Total Solids | 2% |
| Volatile Solids (VS) | 58% |
| VS Destroyed | 11867 lbs/day, 49% |
| Average Temperature | 130°F |
| Biosolids | |
| Wet cake hauled ⁽¹⁾ | 41 wet tons |
| Percent Cake | 23% |
| <i>Sources: LASAN TIWRP Summary of Monthly Report data from May 2015 through April 2016</i> | |
| Note: | |
| (1) Wet cake hauled from May 2015 through December 2015. From December 2015 the vast majority of biosolids were injected into TIRE. | |

7.1.11.9 Recent Upgrades

In recent years there have been limited improvements undertaken to solids processing systems. There are, however, a number of upgrades slated over the next few years. In 2017, the digester insulation and gas utilization system, as well as the dissolved air floatation thickener (CIP 5224) and blending tanks (CIP 5202), are planned to be upgraded. The need for the sludge blending tank is under review. TIWRP intends to reassess the value of the blending tank after DAF modifications have been completed.

7.1.12 Sidestreams

The sidestreams at TIWRP include the centrate stream, the tertiary filter backwash line, the microfiltration backwash line, skimmings from the top of the primary clarifiers, and skimmings from the secondary system. The centrate stream is the water leaving the centrifuges after the solids have been separated and connects to the in-plant sewer flow. The tertiary filter backwash line brings water transporting the dissolved solids collected in the tertiary filters to the primary clarifiers or aeration influent channel. The microfiltration backwash line transports water containing micro-sized particles from the microfilters in the AWPf to connect with the tertiary filter backwash line before going into the primary clarifiers

or aeration influent channel. The primary clarifiers' floatables are pumped to the digesters for treatment. The sidestreams flows are shown in Table 7.16.

| Table 7.16 TIWRP Sidestreams Flows Wastewater Facilities Plan One Water LA 2040 Plan | |
|-----------------------------------------------------------------------------------------------------|--------------|
| Unit | Value |
| Centrate Line | 0.13 mgd |
| Tertiary Filter Backwash Line | 0.55 mgd |
| Microfilter Backwash Line | 1.28 mgd |
| Skimmings (Primary and Final Tanks) | 0.05 mgd |
| <i>Source: Sidestream data provided by TIWRP engineering staff.</i> | |

7.1.12.1 Sidestream Operation

All sidestreams systems are currently on line or in service except the centrate stream. Since TIRE is currently online, the centrifuges are not in operation and there is no centrate produced.

7.1.12.2 Sidestream Current Performance

The connections of the sidestreams into process areas are not optimal. For instance, the microfilter backwash line currently returns the backwash to the primary clarifiers. It may be better from a process standpoint to return the backwash to the aeration tanks feed. A study for sidestreams return optimization will evaluate each sidestream as it is currently recycled to the plant and assess if an alternate return point would be beneficial. With respect to operational optimization, at present the secondary clarifiers skimming system is continuously clogging due to the size constraint of the 4-inch line.

7.1.13 In Plant Storm Drains

According to the Storm Water Pollution Prevention Plan (2009), the TIWRP facility is approximately 90 percent impervious surfaces, consisting primarily of buildings, other structures, and paved areas. To accommodate storm flows, the plant's service roads provide surface drainage while the existing storm drains have been modified to contain the spills and stormwater runoff within the plant. Additionally, sluice gates were installed at the catch basins along the south side of the plant to divert spills and stormwater to the headworks for treatment. When the sluice gates are open, the stormdrain system discharges into the San Pedro Bay. With the sluice gates closed, operating the in-plant drainage system, 100 percent of the stormwater runoff is diverted to the headworks for treatment. It is imperative to keep the runoff in the plant due to the high risk of contamination by pollutant spills within the plant warehouse, maintenance yards, and process facilities (i.e., sludge, grit, motor oil, paint, untreated sewage, digested sludge, wetcake, brine, HPE).

The TIWRP in-plant storm sewer system can handle up to approximately 40 mgd of additional flow due to a storm event. When there is greater than 40 mgd, the sluice gates must be opened to allow for the stormwater runoff to drain to the Harbor. Table 7.17 summarizes the design criteria for the in-plant sewer system at TIWRP.

| Table 7.17 TIWRP In-Plant Sewer Drains Design Criteria Wastewater Facilities Plan One Water LA 2040 Plan | |
|--------------------------------------------------------------------------------------------------------------------------------------------------|----------------------------------|
| Unit | Value |
| In-plant Lift Station Wet Well | |
| Dimensions | 20.5 ft x 27 ft x 13.6 ft |
| Capacity | 56,000 gallons |
| Pump Room | |
| Type/Model | Centrifugal/T-series Gorman-Rupp |
| Number of Pumps | 4 |
| Capacity | 3400 gpm |
| <i>Sources: City of Los Angeles Integrated Resource Plan, 2006, City of Los Angeles Recycled Water Master Planning Long-Term Concepts Report</i> | |

7.1.13.1 Operation

During normal operation, stormwater runoff stays within TIWRP and the additional flow is recycled for further treatment. Minor street flooding can occur, which is considered acceptable. If there is potential for the communication manholes to flood, they must be protected with sandbags. If there is excessive rainfall, the stormwater diversion gates should be opened along the south side of the plant to direct stormwater runoff typically captured within the plant so it can flow offsite and then discharge to the Harbor. The slide gates are located at the storm drain catch basin on the south side of the road across from digester #4, near gate #3, and the storm drain catch basin west of gate #4. It is also necessary to close the plug valves at both of the storm drains to prevent the entry of street runoff into the corridor pump sumps to the in-plant lift stations. If the plant flow rises to 40 mgd, then sandbags are used or the catch basin at gate #1 is sealed off to prevent direct flow into the in-plant lift station.

7.1.13.2 Current Performance

The only concern with the performance of the in-plant storm drains is the entry gate often floods during large rain events; however, upcoming CIP 5834 – Site and Drainage Improvements intends to provide a sump and pumping system at the entry gate to prevent flooding.

7.1.14 Ancillary Facilities

There are a number of facilities at TIWRP that are not a direct part of the process train. These facilities include the service maintenance and warehouse building, administration building, truck scale, and future Educational Enhancement program.

7.1.14.1 Los Angeles Wastewater Integrated Network Systems (LAWINS)

The aging control systems at TIWRP are being updated by Honeywell International Incorporated. Updates include documenting wire terminations, designing and replacing control systems hardware, field cabinetry, development of software, design of control strategies and programming control codes and graphic control screens, design and installation of fiber optic backbone, and process data integration to LASAN business network.

7.1.14.2 Educational Enhancement Program

TIWRP intends to enhance the public perception of the plant through educational features focused particularly on the Advanced Water Purification Facility Expansion. The AWPFF exhibits a "clean look" due to drought tolerant landscaping and educational signs. Tours through the AWPFF follow a clearly identified ADA compliant, educational tour path with four vista points – Equalization Tank/Final Sand Filters, Microfiltration, Reverse Osmosis, and UV/AOP process area. The vista points utilize descriptive signage explaining the process area components and treatment provided. Additionally, there is a stainless steel product water sink for sample viewing. A second focus of the Educational Enhancement is the drought tolerant plant landscaping around the Main Administration Building.

7.1.15 Recent Plant Upgrades

A variety of projects for each of the processes at TIWRP have been planned or are currently underway to increase the plant's overall reliability and efficiency. The following projects in Table 7.18 replaced, rehabilitated or upgraded process components at the plant, and were in construction by March 2017. Planned projects that begin construction after March 2017 are described in Section 7.5 and Appendix H. Planned completion dates are shown in parenthesis at the end of each description. Projects that have been completed are noted as such.

| Table 7.18 TIWRP Recent and Ongoing Plant Upgrades Wastewater Facilities Plan One Water LA 2040 Plan | | | |
|---------------------------------------------------------------------------------------------------------------------|------------------|--------------------------------------|------------------------------------------------------------------------------------------------------------------------------------------------------------------------------------------------------------------------------------------------------------------|
| Process | Project # | Project Title | Project Description |
| Primary | 5206 | Primary Tanks Level Control Upgrades | The level sensors on each of the basins have been relocated to a different section of the tanks to mitigate a problem with false readings which contributed to poor scum collection, damaged flights, and excessive organics entering the secondaries (Complete) |

| Table 7.18 TIWRP Recent and Ongoing Plant Upgrades Wastewater Facilities Plan One Water LA 2040 Plan | | | |
|------------------------------------------------------------------------------------------------------------------------------------------------------------------------------------------|------------------|--------------------------------|---------------------------------------------------------------------------------------------------------------------------------------------------------------------------------------------------------------------------------------------------------------------------------------------------------------------------|
| Process | Project # | Project Title | Project Description |
| Secondary | 5239 | Blowers procurement | The project procured three blowers; two 1,500 hp and one 1,750 hp. (Complete) |
| Secondary | 5240 | Aeration system procurement | The project procured aeration system, aeration piping, and diffusers. (Complete) |
| Secondary | 5159 | Aeration system replacement | The project will replace the existing three air blowers and provide for modifications to the aeration air distribution system consisting. The project includes replacement of air headers with aeration basins and channels; aeration basin downcomers; and air grids, including air system instrumentation and controls. |
| Tertiary | 5229 | Tertiary Filter Rehabilitation | The project will rehabilitated the existing filters to: (1) repair underdrain system, (2) replaced backwash water butterfly valves, (3) replaced filter effluent butterfly valves, (4) replaced and reconfigure air lines, (5) replaced media.(Complete) |
| Effluent Pumping Plant | 5249 | EPP Piping System Improvements | The Effluent Pumping Plant piping system is being upgraded in order to provide flexibility for the proper isolation of equipment. (12/2019) |
| Ancillary Facilities | 5246 | Learning Center | This project created educational elements throughout the AWPF in order to have interactive tours with vista points. (12/2019) |
| <i>Sources: Wastewater Treatment Plants Master Schedule, City of Los Angeles Bureau of Engineering; Wastewater Capital Improvement Program, Clean Water Program, City of Los Angeles</i> | | | |

7.2 IN-PROGRESS PROJECTS

In-Progress projects are planned supply projects for groundwater, recycled water, and stormwater that are expected to be implemented outside and independent of the One Water LA 2040 Plan. For TIWRP, there is one In-Progress Project described in this section. Another In-Progress Project for TIWRP involves the Expansion of NPR per the LADWP 2015 UWMP. The LADWP 2015 UWMP estimated 12,820 AFY of additional recycled water demand in the Harbor Area, some of which would be supplied by TIWRP. Implementation of this project would not require changes to the plant once the expansion of the AWPF is complete.

7.2.1.1 Terminal Island Expansion to 12 mgd

The AWPF expansion at TIWRP (Phase II) provides an additional 6 mgd (total of 12 mgd) of reliable and highly-purified recycled water to further recharge the DGB, supplies recycled water to Harbor Area industrial users, and aids in replenishing the evaporation losses at Machado Lake. The AWPF Expansion was completed during the development of this WWFP and was brought online mid-2017.

7.2.1.2 System Requirements

The end users of the 12 mgd of recycled water to be produced at TIWRP upon completion of the Phase II AWPf were identified in the 2015 TIWRP-DGB Project Engineering Report. Additional distribution is needed to convey recycled water to Machado Lake. The DGB, the Harbor Generation Station (HGS), and future users to be identified will require new infrastructure for pipeline distribution systems. Figure 7.5 shows the recycled water infrastructure from TIWRP AWPf to Harbor Area users. Figure 7.6 shows the locations of each treatment process in the AWPf Phases I and II.

7.2.1.3 Required TIWRP Upgrades

For the Phase II AWPf Expansion, the plant has been upgraded. The Phase I AWPf did not originally utilize AOP. Phase II includes additional MF, RO, and AOP systems and a balance of upgrades to the existing pump stations and systems, chemical addition system, auxiliary systems and utilities. To operate the AWPf at a constant flow, as well as maximize production, Phase II also includes a 2 MG tertiary effluent equalization tank, upstream of the AWPf.

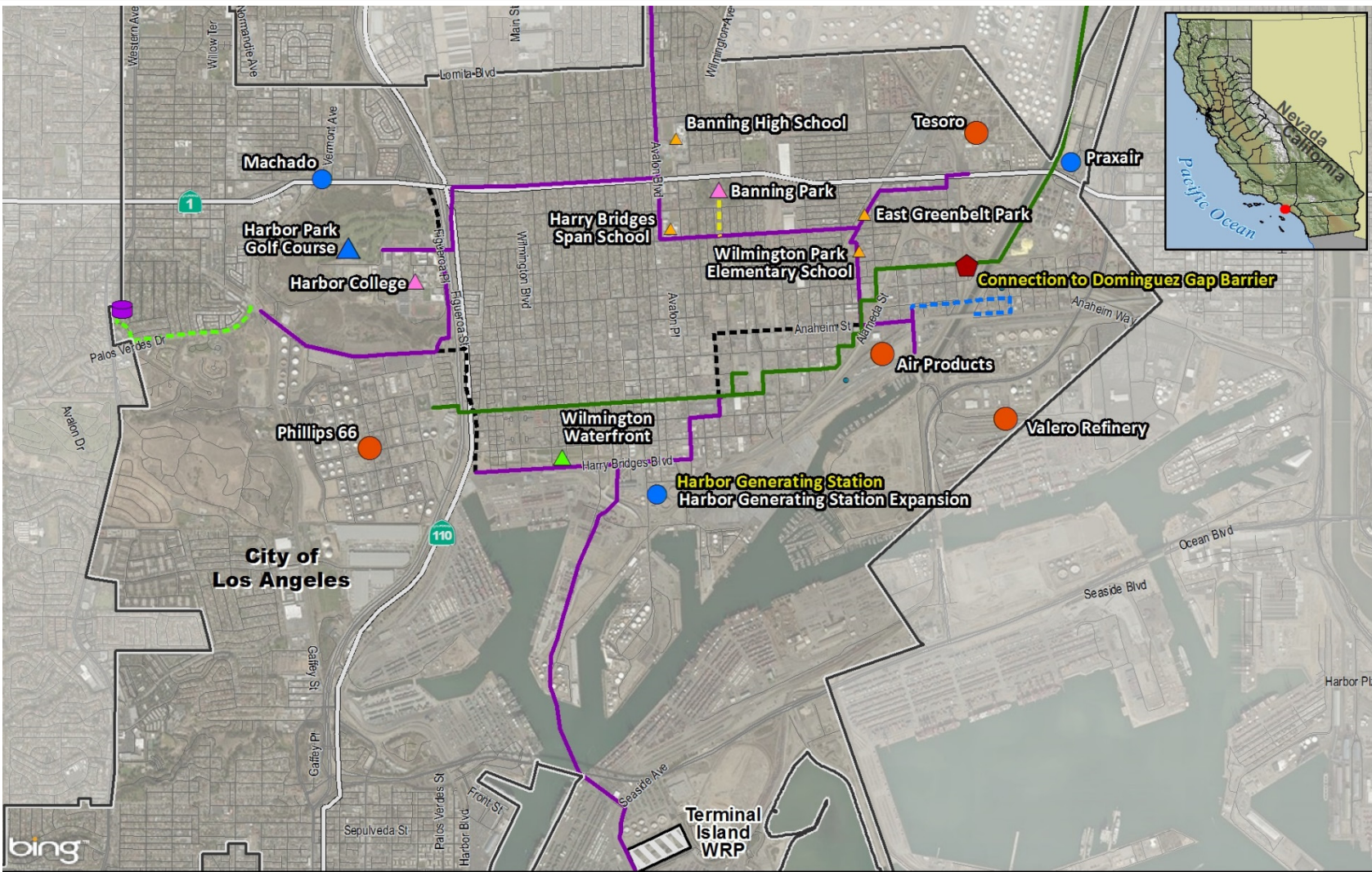

- | | | | |
|-------------------------------------------------------------------------------------------------------------------|------------------------------------------------------------------------------------------------------------------|-----------------------------------------------------------------------------------------------------------------------------------------------------------------------------------------------------------------------------------------------------------------------|---------------------------------------------------------------------------------------------------------------------------------------------------------------------|
| Potential Irrigation-Only Customers ▲ ≥ 5 AFY ▲ ≥ 25 AFY ▲ ≥ 50 AFY ▲ ≥ 100 AFY ▲ ≥ 250 AFY | Potential Non-Irrigation Customers ● ≥ 5 AFY ● ≥ 25 AFY ● ≥ 50 AFY ● ≥ 100 AFY ● ≥ 250 AFY | Existing Facilities/Customers — Pipeline — Dominguez Gap Barrier Proposed Facilities/Customers - - - Machado Lake WRP - - - Proposed Storage Connection - - - Banning Park WRP - - - Dominguez Gap Barrier-Valero Pipeline Project | Other Features ■ Proposed Storage ■ Proposed Connection to Dominguez Gap Barrier □ Treatment Plant ● Existing Customers ● Potential Customers |
|-------------------------------------------------------------------------------------------------------------------|------------------------------------------------------------------------------------------------------------------|-----------------------------------------------------------------------------------------------------------------------------------------------------------------------------------------------------------------------------------------------------------------------|---------------------------------------------------------------------------------------------------------------------------------------------------------------------|

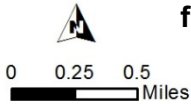
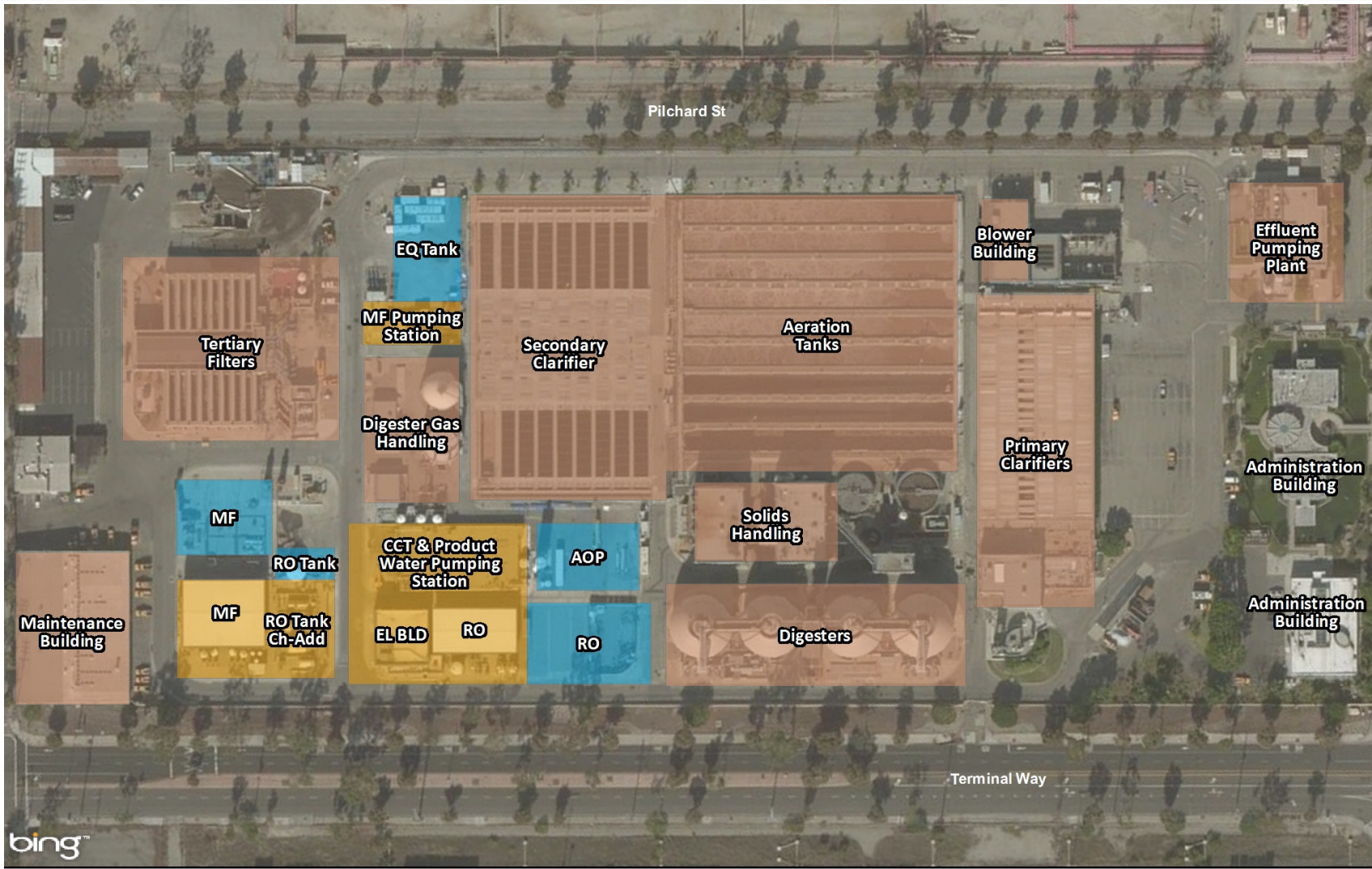

Figure 7.5
Existing and Future RW Distribution System
from TIWRP AWPF to Harbor Area Users
 One Water LA 2040 Plan





- Conventional Treatment System
- AWP Phase 1
- AWP Phase 2

Figure 7.6
Site Layout for Phase 1 and Phase 2 AWP at TIWRP
 One Water LA 2040 Plan

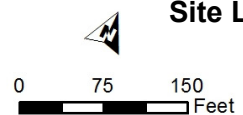

7.3 FUTURE SYSTEM NEEDS EVALUATION

The previous section discussed TIWRP's existing facilities and recent upgrades. In order to optimize plant operations and maximize water reuse potential, future integration opportunities for TIWRP have been examined. This section discusses the projected future flows and availability for water reuse.

7.3.1 Flow Evaluation

In order to identify potential water reuse options that could be implemented at TIWRP, it is important to understand the flows that may be available for water reuse. This section discusses the current and projected influent and effluent flows, which are key in evaluating the future water reuse potential at TIWRP.

7.3.1.1 TIWRP Influent and Effluent Flows

The sewers and force mains in the Terminal Island Service Area include the Terminal Way Force Main, San Pedro Force Main, Fries Ave Force Main, and the Navy Force Main. The total daily flows from these force mains to TIWRP averaged 14 mgd in 2016.

Dry and Wet Weather Flow Diversions

Dry weather low flow diversions from storm drains would add minimal flow to TIWRP's influent. Modeling efforts developed as part of Volume 5 have estimated dry weather low flow diversions adding 0.012 mgd and wet weather flow diversions bringing in an additional 0.007 mgd. However, during recent storm events, actual wet weather flows were greater.

7.3.1.2 TIWRP Planned or Potential Water Reuse

At present, TIWRP produces non-potable reuse water with full advanced treatment from the AWPf. Current uses include industrial users, in plant use, injection in the DGB for seawater intrusion protection as well as groundwater replenishment, and Machado Lake for evaporation loss make-up.

| Table 7.19 TIWRP Projected Wastewater Flows Wastewater Facilities Plan One Water LA 2040 Plan | | | | |
|--------------------------------------------------------------------------------------------------------------------------------------------------|---------------------------------------------------------|---------------|---------------|---------------|
| Flow Source | Projected Wastewater Flows by Year⁽¹⁾ | | | |
| | 2016 | 2020 | 2030 | 2040 |
| Wastewater Influent ⁽²⁾ | 14 mgd | 16 mgd | 18 mgd | 18 mgd |
| Future Dry Weather LFDs ⁽³⁾ | – | – | 0.01 mgd | 0.01 mgd |
| Totals⁽⁴⁾ | 14 mgd | 16 mgd | 18 mgd | 18 mgd |
| Notes: | | | | |
| (1) mgd = million gallons per day | | | | |
| (2) Wastewater Influent values reflect Normal Year hydrological conditions. Additional details of these projected flow values are found in TM2.1 | | | | |
| (3) Future planned LFDs are included in these future flow projections. These LFDs are assumed to be implemented starting in Year 2030. | | | | |
| (4) Flows are rounded to the nearest mgd. | | | | |

Increasing water reuse of TIWRP recycled water will be dependent upon:

- Additional flows to TIWRP
- Increase advanced water treatment capacity
- Identification of new users
- Extension of the water distribution infrastructure

With the AWP Phase II coming online, the recycled effluent will increase from 6 mgd to 12 mgd, resulting in a brine discharge increase from 1.8 mgd to 3.6 mgd.

7.3.1.3 Concept Option Flow Assumptions

The potential concept options consist of various potable reuse options. The estimated yield associated with the potable reuse options are dependent upon TIWRP flows available for water reuse. Due to these considerations the estimated available flow for additional water reuse is limited. A breakdown of the allocated flows and remaining flows available for reuse is detailed in Table 7.20 and Figure 7.7.

| Table 7.20 TIWRP Flow Assumptions Wastewater Facilities Plan One Water LA 2040 Plan | |
|----------------------------------------------------------------------------------------------------|-------------------|
| Flow Component | Flow (mgd) |
| TIWRP 2040 Project Influent Flow | 18 |
| Brine Loss due to AWPf | -3.6 |
| Dominguez Gap Barrier | -7.5 |
| Machado Lake | -0.2 |
| Harbor Other Users | -0.5 |
| Industrial Users and Future Users | -2.5 up to -3.5 |
| Range of Available Flows for Water Reuse | 2.7 to 3.7 |

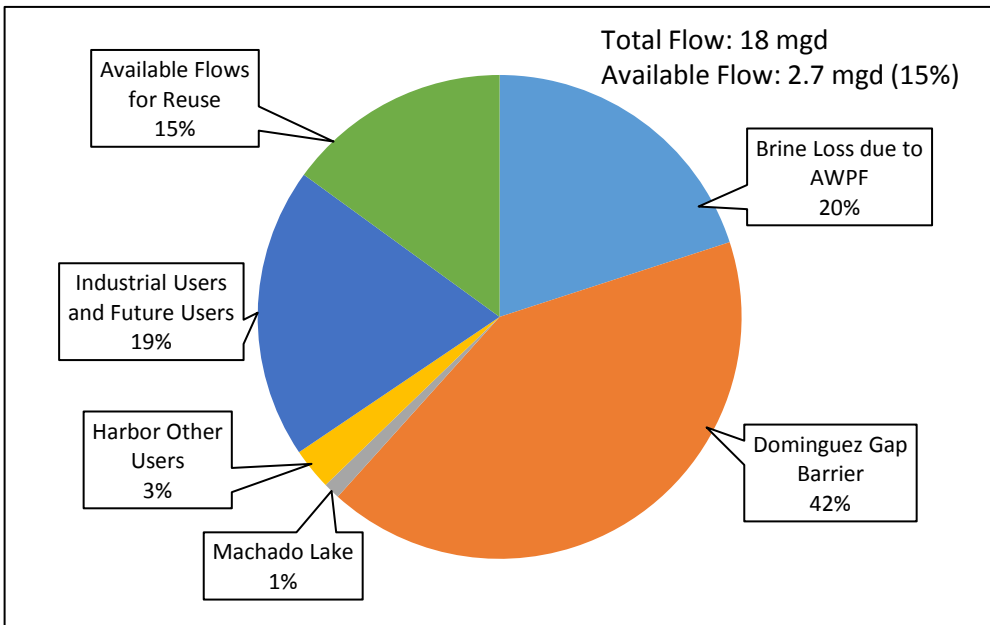

Figure 7.7 Estimated Flow Availability for Water Reuse from TIWRP (2040 Projection)

7.3.1.4 Other Options to Maximize TIWRP Flow

TIWRP is currently capable of producing 12 mgd of non-potable water. It may be capable of increasing its non-potable water production to 24 mgd with the addition of a third train but is currently limited by the influent flow volume. Increasing the incoming flow and expanding the amount of water reuse, is consistent with meeting the Mayor's pLAN and ED#5. Two potential strategies to increase flow to TIWRP are (1) to bring treated flow from HWRP and (2) to divert raw sewage flow from LACSD into the sewershed tributary to TIWRP. These strategies are preliminary in nature merit further discussion with WBMWD and LACSD. Both of these options were studied in 2014, Appendix G contains a summary of the associated reports and an update. Current analysis indicates that the most economical approach to providing increased amounts of recycled water in the Harbor area is to expand WBMWD's Carson AWTF and provide recycled water at the north end of LADWP's recycled water distribution system.

7.3.1.5 Produce Nitrified Denitrified (NdN) Secondary Effluent at HWRP

One alternative to increase flow at TIWRP would be to produce nitrified denitrified secondary effluent at HWRP via MBR technology. This NdN secondary effluent would then be conveyed to TIWRP AWPf via the West Basin distribution system and an extension directly to the TIWRP AWPf. This option would utilize the flow from HWRP to supplement flows to TIWRP, allowing TIWRP to meet customers' demands. Figure 7.8 shows an overview of this alternative.

7.3.1.6 Deliver Raw Sewage from LACSD to TIWRP

The second option to increase flow at TIWRP would be to divert 15 mgd of raw sewage from LACSD's sewer lines into TIWRP's system. The raw sewage may be taken from the Long Beach force main near where it crosses the Dominguez Channel and routed via a 30-inch pipeline to TIWRP. Figure 7.9 presents an overview for this alternative.

Since TIWRP would be receiving additional raw sewage, the entire plant must be able to perform at its design capacity. The advanced water purification facility at TIWRP would need to be expanded to be able to deliver 24 mgd of MF/RO/AOP product water, assuming a recovery rate of 80 percent.

One challenge to capacity expansion at TIWRP is the lack of space on site. Also, the addition of raw sewage from LACSD would increase the influent flow to 30 mgd average day with a corresponding increase in peak flows during wet weather events. Recent storms resulted in flooding and overflow at the headworks due to high influent flows. There is currently a CIP (CIP 8534) to provide a sump and pumping system at the entry gate to mitigate future flooding.

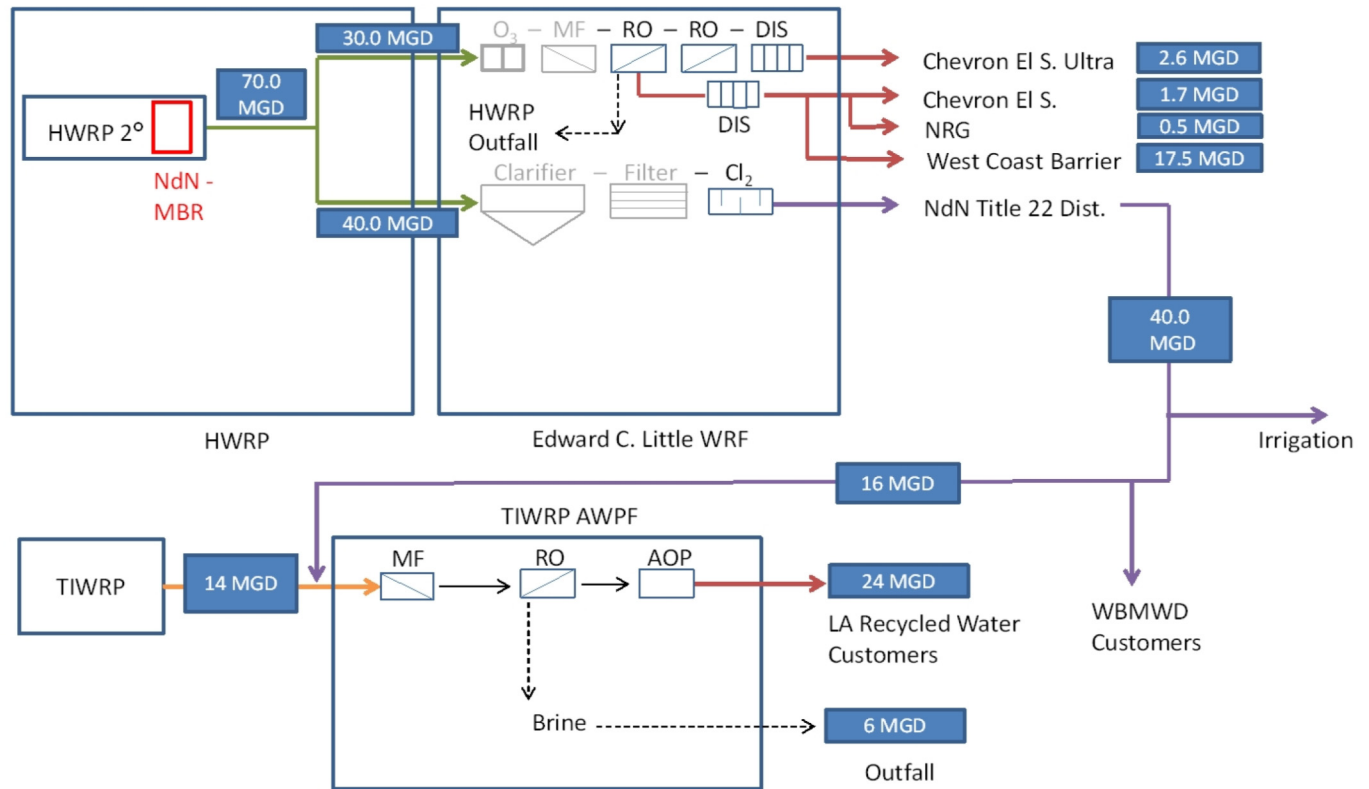
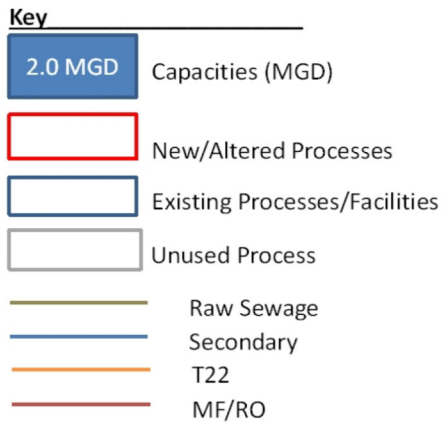

Figure 7.8 - Produce Nitrified Denitrified MBR Secondary Effluent at HWRP
One Water LA 2040 Plan



Key

- 2.0 MGD Capacities (MGD)
- New/Altered Processes
- Existing Processes/Facilities
- Unused Process
- Raw Sewage
- Secondary
- T22
- MF/RO

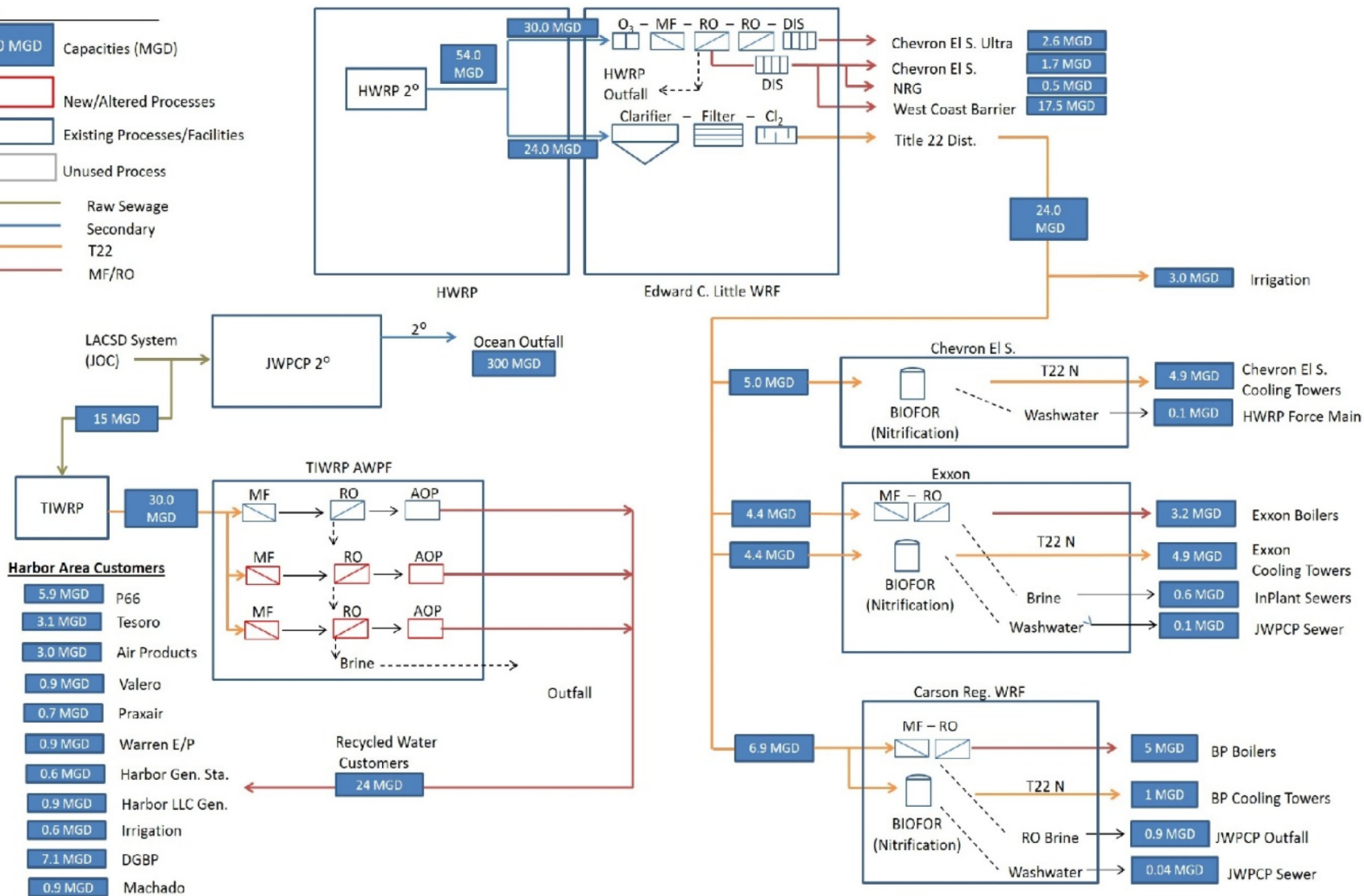

Figure 7.9 - Transfer Raw Sewage from the LACSD System to TIWRP
One Water LA 2040 Plan



Potential Upgrades to the Conveyance System

Potential upgrades may be needed to the conveyance system in order to increase the non-potable water flow at TIWRP are shown in Table 7.21. TIWRP must operate as a base load plant where there is always enough demand to ensure full use of the recycled water.

| Table 7.21 Alternatives to increase flow to TIWRP Wastewater Facilities Plan One Water LA 2040 Plan | | | |
|---------------------------------------------------------------------------------------------------------------------------------------------------------------------|----------------------|------------------|----------------------------------------------------------------------------------------------------------------------------------------------------------------------------------------------------------------------------------------------------------------------------------------------------------------------------------------------------------------------------------------------------------------------------------------------|
| Option | Water Quality | Flow Rate | Required Upgrades |
| Deliver MBR Effluent from HWRP to TIWRP AWPf ⁽¹⁾ | MBR Effluent | 15 mgd | <ul style="list-style-type: none"> • Expanded 70 mgd pump station at HWRP (HEPS) to pump to ECLWRF • 42-inch north-south connection along Prairie Avenue between the existing 36-inch main on West 120th Street and the existing 42-inch main on Marine Avenue to connect ECLWRF to Carson Regional Water Reclamation Facility (CRWRF) • 15 mgd pump station and 30-inch pipeline connecting CRWRF to TIWRP |
| Deliver Raw Sewage from LACSD to TIWRP | Raw Sewage | 15 mgd | <ul style="list-style-type: none"> • 15 mgd pump station from LACSD • 30-inch pipeline from the Long Beach force main near the Dominguez Channel • 12 mgd expansion of AWPf at TIWRP |
| Note: (1) A subset of this option could be to add 15 mgd of RO at TIWRP instead of increasing the AWPf. The MBR effluent from HWRP would bypass the AWPf. | | | |

In order to eliminate the potential for effluent harbor discharge, advanced treated water sourced from other treatment facilities will be needed to supply peak demands in the Harbor area.

7.3.2 Concept Option Development

The preliminary list of concept options that support a locally sourced water supply was developed through workshops that solicited ideas and input from a workgroup as well as community stakeholders. This workgroup included contributors from an array of communities, LASAN, LADWP, other City Bureaus and Departments and select technical advisors. These ideas resulted in the development of concept options within the 2040 planning horizon. Concept options represent new concepts that have not been previously evaluated by the City. With this methodology, a list of 27 concept options was developed for the entire system. However, due to the flow limitations, no concept options were identified.

7.3.2.1 Additional Projects for Consideration

In addition to the In-Progress Project, this section summarizes projects that may be or are being considered in the future. These projects are preliminary in nature and scope will need to be developed should the LASAN TIWRP staff decide to evaluate them further. Table 7.22 summarizes these projects.

| Table 7.22 Additional Projects for Consideration Wastewater Facilities Plan One Water LA 2040 Plan | |
|-------------------------------------------------------------------------------------------------------------------|---------------------------------------------------------------------------------------------------------------------------------------------------------------------------------------------------------------------------------------------------------------------------------------------------------------------------------------------------------------------------------------------------------------------------------------------------------------------------------------------------------------------------------------------------------------------------------------------------------------------------------------------------------------------------------------------------|
| Process | Project Description |
| Collection System | <p>Perform study to identify source of excessive wet weather flows affecting TIWRP capacity.</p> <p>Implement Sewer Monitoring and Routing Terminal (SMART Sewer) that will be a system of flow monitoring or sewer d/D recordings at key stations with the resulting data utilized in a near real time model to determine available sewer capacity such that wet weather storm flows could be routes or diverted into the collection system at controlled interconnections. All of these actions would be monitored and controlled at a central terminal. This is a sewer system inflow strategy to control stormwater flows in sewers and utilize available capacity for flow equalization.</p> |
| Hydraulics | <p>Evaluate performance of influent venturi meters and make adjustments/replacement as required.</p> <p>Perform a hydraulic analysis of the present condition at TIWRP. Identify process bottlenecks and areas sensitive to flooding.</p> <p>Design and install a new influent sampling station. This project will remove and replace the sampling pumps, influent sampling lines, and monitoring meters for the existing system. (CIP 5222)</p> |
| Advanced Treatment | Conduct a studies of alternative technologies for advanced treatment. |
| Gas Utilization | Perform a gas utilization study to address the following alternatives: (1) a pipeline to transmit quality gas to the distribution system, (2) micro gas turbines for cogeneration, (3) fuel cells, or (4) improve gas quality for the existing boilers. |
| General | Continue research and product evaluation to identify technologies that will minimize power and chemical usage throughout the plant. |

7.4 CLIMATE RISK AND RESILIENCE ASSESSMENT

Climate change is projected to impact the City's wastewater and stormwater systems in a variety of ways. The wastewater systems consist of sewer systems, sewage pumping facilities, wastewater treatment facilities and water reclamation facilities. Changes in temperature, precipitation, and sea levels will affect the physical plant and operational vulnerabilities of these facilities and operations.

A climate risk and resilience assessment was performed consisting of scenario development, screening analyses, site visits, risk analyses, and adaptation planning concurrent with meetings with LASAN staff. Current and potential future climate conditions were incorporated into the assessment and development of recommendations. Subsequently, practical improvements for the WRPs were identified to mitigate these risks.

A detailed description of the climate risk assessment of TIWRP is included in Chapter 10, while the findings and recommendations are summarized in this section.

TIWRP is surrounded by flood hazard zones and is in a tsunami zone. Climate change conditions of increasing temperatures and SLR may affect power supply, coastal flooding, and tsunami hazards. Increased temperatures and extreme events may cause more frequent power interruptions at TIWRP. Assessments were performed on the flooding and power failure risks with climate change considerations to identify resilience improvements that address these risks. The overall current and future climate hazards risk assessment for TIWRP is high due to the flood hazard and backup power deficiency.

Capital facility planning recommendations with conceptual construction costs for TIWRP are as follows:

- Add backup power generation to power the entire facility - \$4,000,000
- Construct flood walls and add structures and gates - \$3,730,000

No additional capital or non-capital resilience improvements are recommended for TIWRP at this point in time. Other climate change considerations may be assessed in the future.

7.5 TIWRP ADAPTIVE CIP

A comprehensive wastewater facilities Capital Improvement Plan (CIP) has been developed for all four WRPs and the collection system, located in Chapter 11 of this Volume. The purpose of this section is to summarize the capital improvement projects identified for TIWRP. The sources used to develop the summary CIP include the Los Angeles Bureau of Engineering (LABOE) Uniform Project Reporting System (UPRS), LASAN Wastewater Capital Improvement Plan (WCIP), LADWP 2015 UWMP, and concept options developed as part of the One Water LA 2040 Plan.

The development of the TIWRP Adaptive CIP compiles the projects previously discussed in this chapter with the WCIP developed by the City. The projects for TIWRP are classified as follows:

- In-Progress Projects
- Estimated and Projected CIP

The costs for the Estimated and Projected CIP are presented by category and phase, defined in Table 7.23. Project costs are then summarized and escalated based upon implementation schedule. The CIP for TIWRP represents one component of the overall WWFP Adaptive CIP. The details for cost estimating methodology are summarized in Chapter 11.

| Table 7.23 CIP Terms and Definition Wastewater Facilities Plan One Water LA 2040 Plan | | |
|------------------------------------------------------------------------------------------------------|--------------------------------------------|------------------------------------------------------------------------------------------------------------------------------------------------------------------------------------------------------------------------------------------------------------------------------------------------------------------------------------------------------------------------------|
| Group | Term | Definition |
| Category | Capital Project from WCIP | These projects were previously identified in the WCIP. These projects include new construction, expansion, or renovation that helps maintain or improve a City facility or infrastructure that may be funded by the Capital Budget |
| | R&R from WCIP | These are projects identified in the WCIP. These projects are needed for the continued operation of the facility in its present form. |
| | Climate Resiliency Projects ⁽¹⁾ | These are projects developed as part of the Plan and identified in Volume 6 Climate Risk and Resilience Assessment for Wastewater and Stormwater Infrastructure. These projects are needed to adapt to environmental conditions due to climate change |
| | Projected Capital Projects | These are projects not identified in the WCIP and are projected as part of the WWFP in collaboration from City staff. These projects include new construction, expansion, or renovation that helps maintain or improve a City facility or infrastructure that may be funded by the Capital Budget. Project costs were estimated using a methodology described in Chapter 11. |
| | Projected R&R Projects | These are projects not identified in the WCIP and are projected as part of the WWFP in collaboration with City staff. These projects may be needed for the continued operation of |

| Table 7.23 CIP Terms and Definition Wastewater Facilities Plan One Water LA 2040 Plan | | |
|------------------------------------------------------------------------------------------------------|-----------|------------------------------------------------------------------------------------------------------|
| | | the facility in its present form. These projects were estimated using the methodology in Chapter 11. |
| Phase ⁽²⁾ | Near-Term | Projects that are planned to be constructed between 2018 to 2020 |
| | Mid-Term | Projects that are planned to be constructed between 2021 and 2030 |
| | Long-Term | Projects that are planned to be constructed between 2031 and 2040 |
| Note: | | |
| (1) Climate resiliency projects were identified based on the analysis described in Volume 6. | | |
| (2) The phases were determined by LASAN and LADWP management for all projects included in the Plan. | | |

The following sections use the sources, methodologies, terms and definitions to present the In-Progress Projects and Estimated and Projected CIP for the TIWRP Adaptive CIP.

7.5.1 TIWRP In-Progress Projects

Table 7.24 summarizes the In-Progress Projects, estimated capital costs, projected construction completion, and resulting phase for TIWRP. Additional details of the In-Progress Projects were previously summarized in Section 7.2.

| Table 7.24 Summary of TIWRP In-Progress Project Estimated Costs Wastewater Facilities Plan One Water LA 2040 Plan | | | |
|-----------------------------------------------------------------------------------------------------------------------------------------------------------------------------|------------------------------------------------------------------|--------------------------|--------------|
| In-Progress Projects | Estimated Capital Cost Estimate (\$2017) Millions | Year Complete | Phase |
| Terminal Island AWP Expansion to 12 mgd | \$77 ⁽¹⁾ | 2017 | Near |
| Total | \$77 | | |
| Note: | | | |
| (1) TIWRP Expansion to 12 mgd was completed during the finalization of the WWFP. For this reason, it has not been included in the TIWRP Adaptive CIP and WWFP Adaptive CIP. | | | |

The above In-Progress Project was completed during the development of the WWFP and therefore is not included in the TIWRP Adaptive CIP or the Wastewater Facilities Adaptive CIP.

7.5.2 TIWRP Estimated and Projected CIP

The Estimated and Projected CIP is based on the WCIP, plus the climate risk analysis. In areas lacking any estimate of costs, a set of assumptions are used to develop projected costs for annual capital and replacement and rehabilitation projects. Details of these assumptions are summarized in Chapter 11. The Estimated and Projected CIPs for TIWRP are provided in Table 7.25 and Figure 7.10. The details of the summary table can be found in Appendix H.

| Table 7.25 TIWRP Estimated and Projected CIP Wastewater Facilities Plan One Water LA 2040 Plan | | | |
|---------------------------------------------------------------------------------------------------------------|-----------------------------|------------------------------------|------------------------------------|
| | Category | Total (\$2017) Millions | Total (\$2017) Millions |
| Near-Term | Capital Project from WCIP | \$17 | \$65 |
| | R&R from WCIP | \$48 | |
| | Climate Resiliency Projects | - | |
| | Projected Capital Projects | - | |
| | Projected R&R Projects | - | |
| Mid-Term | Capital Project from WCIP | \$18 | \$34 |
| | R&R from WCIP | \$16 | |
| | Climate Resiliency Projects | - | |
| | Projected Capital Projects | - | |
| | Projected R&R Projects | - | |
| Long-Term | Capital Project from WCIP | - | \$204 |
| | R&R from WCIP | \$12 | |
| | Climate Resiliency Projects | \$14 | |
| | Projected Capital Projects | \$140 | |
| | Projected R&R Projects | \$38 | |
| | | Total | \$303 |

Table 7.25 shows that the majority of the Estimated and Project CIP costs are anticipated to occur in the long-term phase. The near and mid-term phases use the projects identified in the WCIP, whereas projections were used for the majority of the long-term phase costs. These projections are to account for future, but undefined costs that may occur at TIWRP. The same information is shown graphically on Figure 7.10.

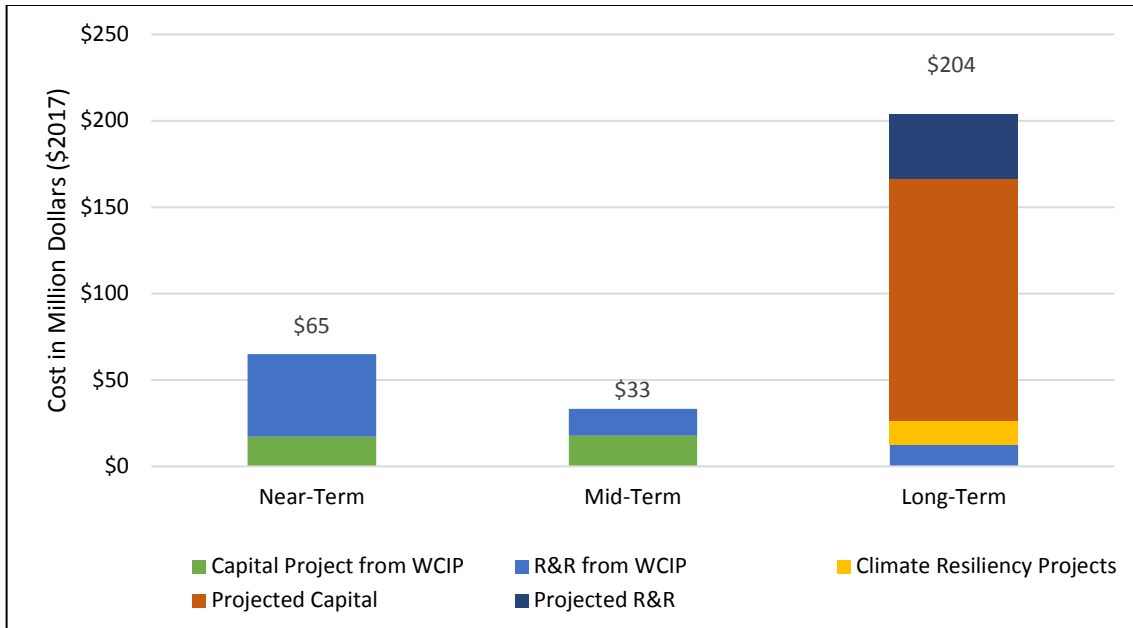

Figure 7.10 Summary of TIWRP Estimated and Projected CIP Costs

The CIP for TIWRP has the highest cost in the long-term phase, as seen in Table 7.25 and on Figure 7.10. Costs in the near-term phase and the mid-term phase consist of capital projects and replacement and rehabilitation as identified in the WCIP. The long-term phase consists mostly of projected capital projects, in addition to projected replacement and rehabilitation, climate resiliency projects, and replacement and rehabilitation from the WCIP. The Estimated and Projected CIP costs summarized in Table 7.25 translates to an average cost of approximately \$22 million per year from 2018 to 2020, \$3.4 million per year from 2021 to 2030, and \$20.4 million per year from 2031 to 2040. Figure 7.11 presents the same Estimated and Projected CIP information as Table 7.25 but depicts the total value by percent allocated to each category. The Projected Capital projects category is the largest of the five, due to the inclusion of calculated values.

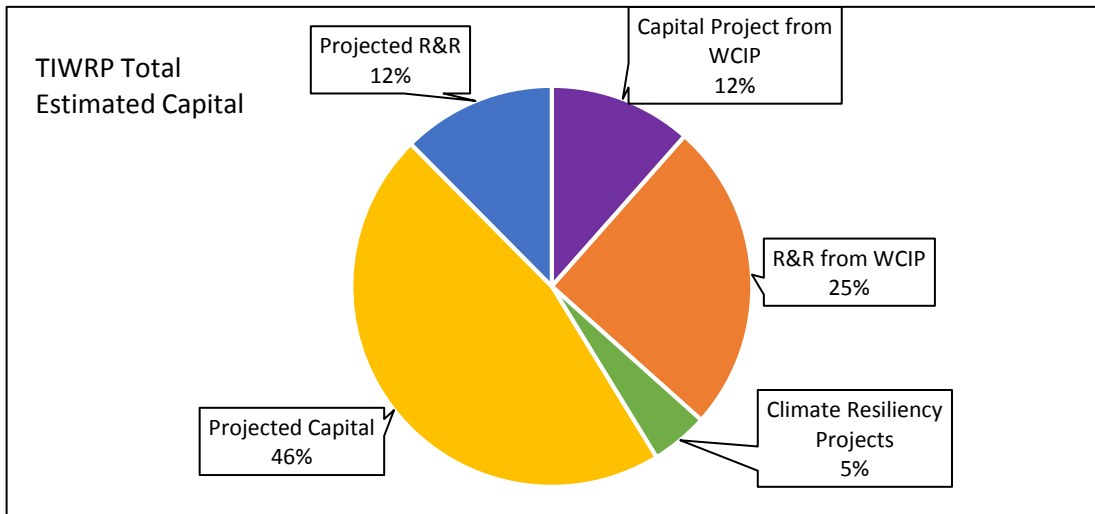

Figure 7.11 TIWRP Estimated and Projected CIP Costs by Category

7.5.3 TIWRP Adaptive CIP Summary

The combination of the In-Progress Projects and Estimated and Projected CIP serve as the basis for the TIWRP portion of the WWFP Adaptive CIP and are summarize in 2017 dollars in Table 7.26.

| Table 7.26 TIWRP Adaptive CIP Summary 2017 (\$M) Wastewater Facilities Plan One Water LA 2040 Plan | | | | |
|---------------------------------------------------------------------------------------------------------------------------------------------------------------------------|--------------------------------------------|-------------------------------------------|--------------------------------------------|------------------------|
| Category | Near-term (2018-2020) (\$M) | Mid-term (2021-2030) (\$M) | Long-term (2031-2040) (\$M) | Total (\$M) |
| In Progress Projects | | | | |
| Terminal Island AWP Expansion to 12 mgd | — ⁽¹⁾ | \$0 | \$0 | — ⁽¹⁾ |
| Subtotal | \$0 | \$0 | \$0 | \$0 |
| Estimated and Projected CIP | | | | |
| Capital Project from WCIP | \$17 | \$18 | - | \$35 |
| R&R from WCIP | \$48 | \$16 | \$12 | \$76 |
| Climate Resiliency Projects | - | - | \$14 | \$14 |
| Projected Capital Projects | - | - | \$140 | \$140 |
| Projected R&R Projects | - | - | \$38 | \$38 |
| Subtotal | \$65 | \$34 | \$204 | \$303 |
| Total | \$65 | \$34 | \$204 | \$303 |
| Note: | | | | |
| (1) TIWRP Expansion to 12 mgd was completed during the finalization of the WWFP. For this reason, it has not been included in the total cost of the In-Progress Projects. | | | | |

The overall CIP in 2017 dollars for TIWRP is \$303 million, between 2018 and 2040, which equates to roughly \$12.6 million per year. The majority of the expenditures are anticipated to fall within the long-term phase. This is driven by the projected CIP values that were calculated. This same information is presented graphically on Figure 7.12.

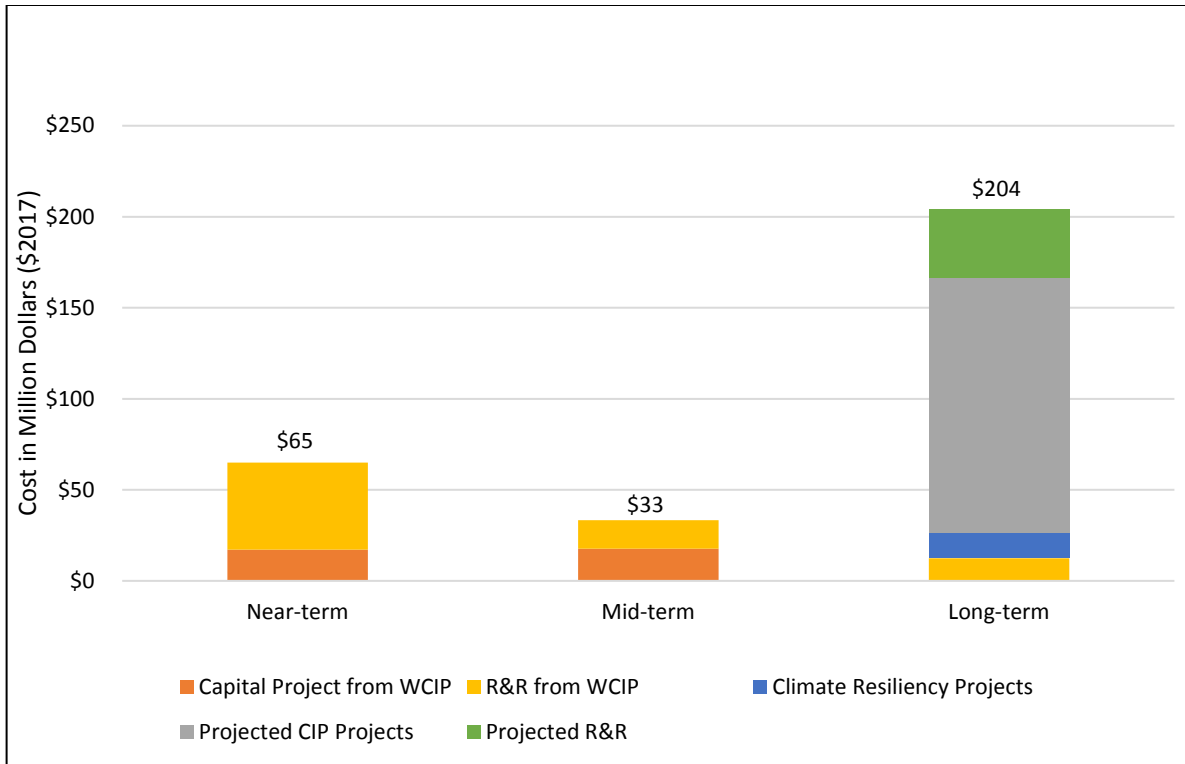

Figure 7.12 TIWRP Adaptive CIP Summary by Phase

Since the TIWRP In-Progress Project has been completed and no future integration opportunities were identified, the TIWRP Adaptive CIP consists solely of the Estimated and Projected CIP. As a result, Figure 7.12 mirrors the previous Figure 7.10. The costs in the TIWRP Adaptive CIP are presented in 2017 dollars but future costs should be adjusted to account for the time value of money. Section 7.5.4 discusses the escalation methodology used to account for these future values.

7.5.4 TIWRP Adaptive CIP Net Present Worth Summary

The values for each of the projects were developed in 2017 dollars. Recognizing that the City will not implement all projects immediately, the projects have been divided into phases. The costs for the projects that are scheduled to be implemented in the near, mid, and long-term were adjusted to account for inflation and, escalated at a rate of 3 percent per year. To allow a comparison of costs between phases, the escalated costs were brought back to a present value using a discount rate of 2 percent per year. Discounting the escalated costs yields a net present value and reflects the future values in 2017 dollars.

The net present worth of the TIWRP Adaptive CIP is \$345 million. For the 2040 planning horizon, this total value equates to \$15 million on an annual basis. Figure 7.13 shows how the time value of money impacts each of the phases of the CIP.

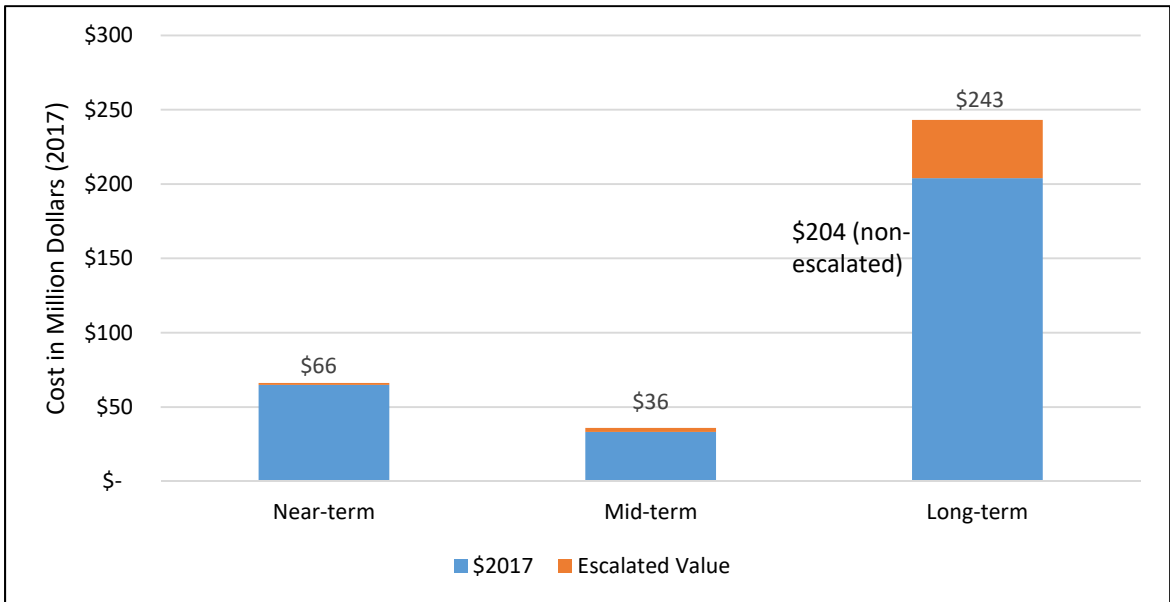

Figure 7.13 Present Worth Comparison: Escalated versus Non Escalated CIP

The long-term phase has the greatest impact on the CIP, due to the large amount of money that needs to be accounted for in today's dollars.

-This Page Left Blank Intentionally-

POTENTIAL FUTURE WATER RECLAMATION PLANTS

In addition to analyzing future projects at the four WRPs, the City is also evaluating the option of potential future WRPs. These plants would consist of on-site treatment to service smaller areas of the City where water reuse demands are not currently met..

8.1 ON-SITE TREATMENT EVALUATIONS SUMMARY

On-site treatment facilities (OSTFs) are small facilities at or near point-of-use locations in LASAN's service area. OSTFs would be located upstream of one of the City's WRPs, to serve specific non-potable water demands or for groundwater replenishment. OSTFs could be owned by the City or private entities and may or may not include solids treatment. LASAN does not currently have a policy that regulates or prevents other entities from performing on-site treatment.

In a broad sense, the term "on-site treatment" may refer to various types of treatment scenarios. In this section it is used to describe two specific configurations:

1. Reclaimed water treatment systems developed and owned by the City, potentially in partnership with another entity, such as a university or a contract city. The treatment system would treat nearby sewer flows and is assumed to not include solids treatment. Depending on the desired water quality, the on-site treatment may include RO or other processes that will generate a brine.
2. Reclaimed water treatment systems developed and owned by private entities to reclaim water on-site to reduce their potable water demand and/or for pre-treatment of industrial discharges. This on-site treatment could concentrate constituents in the resulting waste stream.

Additional OSTFs could also be implemented throughout the City service area and serve local needs of smaller areas. Demands for this water could come from industries who may have recycled water uses. However, complete bypass around the OSTF and back-up potable water supplies would be required to ensure failsafe disposal during process upsets or facility maintenance.

There are two potential on-site treatment schemes that are considered in this evaluation:

1. An OSTF that includes both secondary and advanced treatment processes (RO and advanced oxidation) with waste activated sludge treated on-site and RO concentrate discharged to LASAN's sewer.

2. Production of recycled water on-site to offset potable water demands for irrigation, cooling towers, and other process uses. Non-reclaimable wastes could include primary and/or waste activated sludge, which could either be treated on-site or returned to the sanitary sewer collection system for further treatment and disposal downstream by LASAN.

Considerations for new OSTFs stems from potential financial impacts from declining revenues, as well as treatment and conveyance impacts due to changes in wastewater quality, such as BOD and TSS concentrations.

8.1.1 Evaluation of Impacts

Privately owned OSTFs could have financial impacts to LASAN. This could include revenue loss leading to increase rates. The potential revenue loss would be a result of on-site facilities reducing flows that would otherwise have entered the collection system and treated at an LASAN WRP. OSTFs would reduce potable water purchases from LADWP but the dischargers would still be subject to sewer service charges (SSCs) and possible quality surcharge fees (QSFs) to LASAN if solids are returned to the sewer. If revenue is lost, LASAN would potentially have to raise rates. Other alternatives for revenue may be considered, such as standby charges or facility inspection and permit fees.

OSTF projects could also impact existing wastewater facilities, including the collection system, WRPs and plans for potable reuse. The projects could potentially reduce the amount of wastewater discharged to the collection system and increase the concentrations of BOD and TSS if solids are returned to the sewers and subsequently the WRPs. This could lead to solids build-up in the sewer system, resulting in odor issues, corrosion, and restrictions that would require additional operation and maintenance (O&M). However, reduced flows could be beneficial to sewers that are near capacity.

Effects to the WRPs is dependent on the type of treatment performed at the OSTFs. However, the primary impact of the OSTFs would be the discharge of brine, waste activated sludge and inert material which will require operational changes and additional maintenance and costs at the downstream WRPs. Additional treatment processes for non-potable/potable reuses would also be impacted if the OSTFs discharge RO concentrate which would increase the TDS entering the plants. However, the impacts of OSTFs to the wastewater facilities would need to be evaluated and mitigated on a case-by-case basis.

8.1.2 Policy Recommendations

The impacts of each potential OSTF could vary depending on location, size, discharge characteristics, and the water reclamation facility to which they are tributary. Therefore, a prescriptive policy would be difficult to implement as it would not apply across the board. It is recommended that LASAN establish guiding principles that will be taken into consideration during the approval and review processes of a proposed OSTF by LASAN. These guiding principles may include, but are not limited to, the following:

- Existing customers will not pay or subsidize, directly or indirectly, in any way the capital cost or operations of privately owned OSTF.
- Wastewater shall not be taken from LASAN sewers. Such removal may impair the operation of LASAN's system and the City's recycled water program, i.e., reduces the amount of recycled water available for LADWP customers.
- LASAN will not be responsible for the operation or maintenance of privately owned OSTFs. Owners/Operators of privately owned OSTFs will be required to indemnify LASAN.
- Owners/Operators of private OSTF will be solely responsible and liable for any and all damages incurred.
- OSTFs will be required to develop a failure plan that demonstrates that 100 percent of the flows can be disposed in the event of a system failure and may be required to maintain a back-up service for their system.
- Proper operations and maintenance are required for the sustainability of the OSTF. The design, operation, and maintenance are performed by qualified individuals and approved by LASAN.
- LASAN will evaluate impacts of proposed OSTFs and will specify requirements. LASAN may limit materials that can be returned to the existing sewer, or may assess additional fees.

In addition to these guidelines, two policy recommendations were identified. These recommended policies include (1) developing guidelines that protect public health and outline operations of wastewater and recycled water systems (#38) and (2) providing a fee structure and payment guidelines that reflect collection and treatment system impacts and cost (#39). Stakeholders also recommended expanding educational and engagement programs on Potable Reuse (#35).

8.2 RANCHO PARK WATER RECLAMATION FACILITY

In addition to the four existing WRPs, the options for one or more new WRPs was evaluated as part of the One Water LA 2040 Plan and is provided in Volume 6. Based on the analysis, it was concluded that the most beneficial location to potentially add a new WRP is near Rancho Park in the Westside Area. The result of this analysis identified Rancho Park Water Reclamation Facility as one of the top current integration opportunities. The Rancho Park Water Reclamation Facility concept is undergoing review and development, alternate locations are being evaluated to minimize recycled water distribution system costs.

Although this project concept is still under development, the current conceptual project components of the Rancho Park Water Reclamation Facility project include:

- Component 1 – Stormwater capture and treatment system to supplement irrigation demands at the Rancho Park Golf Course and Cheviot Hills Recreation Center.
- Component 2 – Satellite WRP to meet non-potable demands in the regional service area, including potential recycled water delivery to the UCLA campus.
- Component 3 – Expansion of satellite WRP to meet peak seasonal non-potable demands in the regional service area.

The Rancho Park Water Reclamation Facility would produce recycled water. The recycled water would be augmented with dry weather runoff and stormwater, when available, to serve non-potable water demands near Rancho Park (West LA).

In Component 1, a stormwater capture and treatment system would produce treated water suitable for non-potable reuse (e.g. irrigation) that complies with the standards for disinfected tertiary recycled water uses in Title 22 of the California Code of Regulations (CCR). To meet compliance with the standards set forth in Title 22, the treatment system would utilize filtration and UV disinfection. The recommended concept includes the following stormwater Best Management Practices (BMPs) and technologies:

1. A lift station to divert stormwater from the identified confluence point in the storm drain system next to the golf course.
2. A hydrodynamic separator to remove trash, suspended solids, and oil and grease.
3. An underground stormwater storage tank to hold diverted stormwater runoff for subsequent treatment.
4. Title 22 approved non-granular media filter to reduce turbidity.
5. UV disinfection system to remove pathogens from the stored water prior to water reuse.
6. An underground storage tank to hold treated water until needed for irrigation.

Following storm events, the treatment system would provide 1.26 mgd of disinfected tertiary recycled water (Title 22 water) to meet irrigation needs at the golf course and recreation center. By capturing and reusing the runoff, the entire load of pollutants of concern in the captured runoff, including bacteria, would be removed from the discharge to the downstream Ballona Creek.

In Component 2, a satellite WRP will produce treated wastewater that has undergone the equivalent of preliminary, primary, and secondary treatment plus tertiary filtration and subsequent disinfection to comply with the standards for disinfected tertiary recycled water uses in Title 22. To meet compliance with the standards set forth in Title 22, the satellite WRP would utilize MBR and UV disinfection with an ADF treatment capacity of 2.5 mgd initially to meet the regional average day recycled water demands. Potable water

augmentation would be needed to supplement flows and meet peak demands at this treatment capacity.

In Component 3, the satellite WRP would be increased to an ADF of 4.23 mgd to meet peak day recycled water demands without potable water augmentation. Optional treatment of a portion of the product water with RO may be desired based on specific end user water applications. These treatment technologies were selected based on ability to meet several criteria including: (1) reliability and proven technology; (2) compliance with Title 22; (3) capability of remote operation; (4) compact site footprint; and (5) low environmental impact.

The three-component, integrated approach would be a multi-benefit project that provides:

1. Produces recycled water to meet substantial non-potable demands in the Westside area, including industrial uses and irrigation for the UCLA campus, the City's largest municipal golf course, and several other users.
2. Captures stormwater to retain, treat, and remove pollutants such as trash, metals, and bacteria.
3. Increases reliability of supply by being locally sourced and climate resilient.

Successful implementation of this project requires thoughtful, proactive communication both within City government and with the surrounding community.

8.3 FLOW ROUTING CHANGES AND IMPACT

One of the many goals of One Water LA 2040 Plan is to identify integrated, multi-benefit project opportunities. The stormwater and recycled water reuse elements of the Rancho Park concept provides an excellent opportunity for integration into a single project. However, the project will affect flow routing in the area and may lead to impacts at the downstream water reclamation plant HWRP. The following subsections evaluate potential flow impacts from the Rancho Park project.

8.3.1 Flow routing to the new WRP

Due to the potential co-location of Components 1, 2, and 3 at the golf course/recreation center, there is a significant opportunity to integrate both the stormwater and satellite WRP facilities. This would streamline construction schedule and reduce costs by sharing infrastructure and centralizing the O&M of both systems.

8.3.1.1 Stormwater Supply for Component 1

The Component 1 stormwater concept has a capture goal of the runoff associated with the 85th percentile, 24-hour storm event. Sufficient raw stormwater storage would be required to attenuate and retain the runoff captured from this design storm before it is treated and reused. Figure 8.1 delineates the drainage area that is upstream of project site.

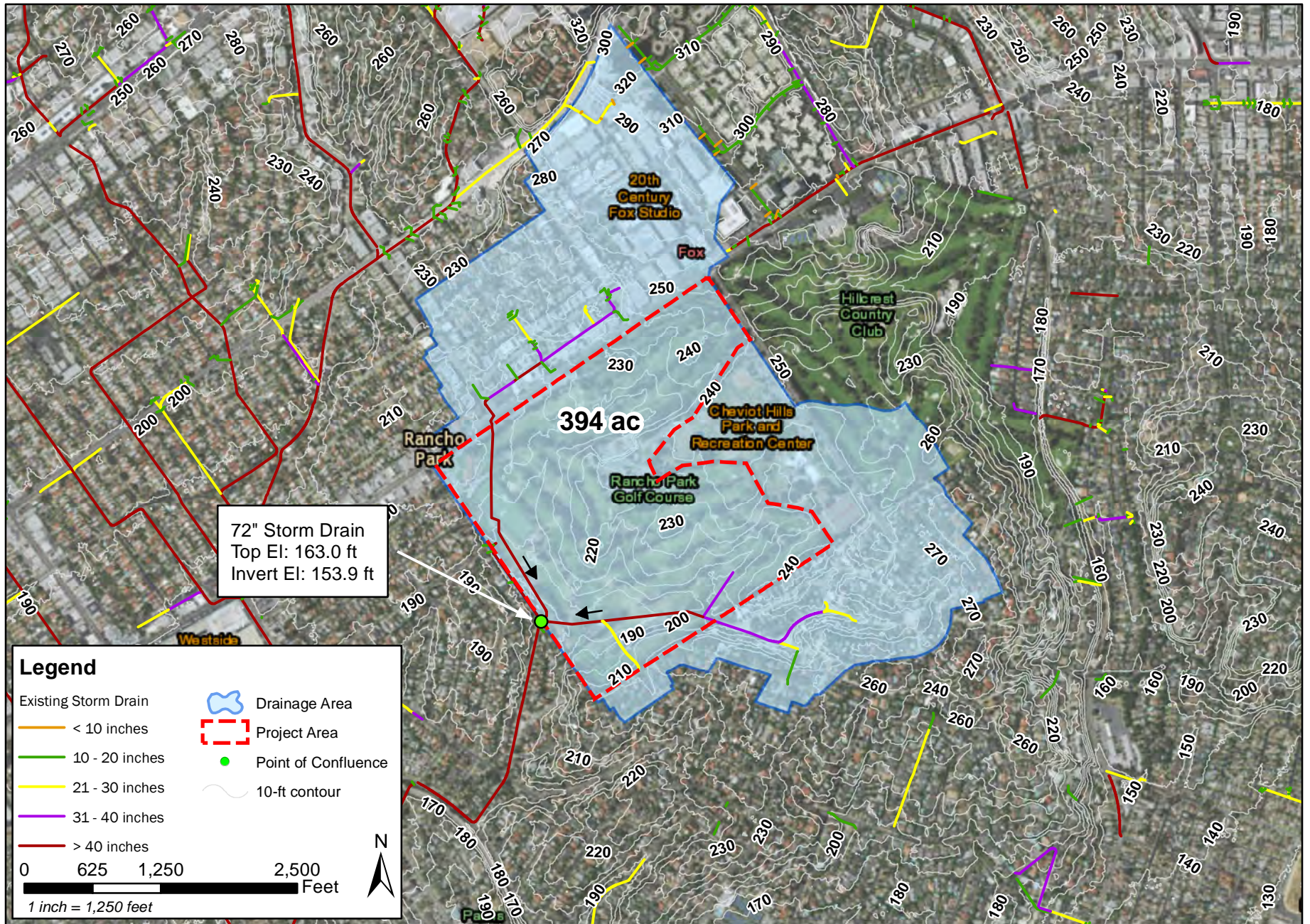

Figure 8.1
Rancho Park Drainage Area map
One Water LA 2040 Plan

Reference: Service Layer Credits: Source: Esri, DigitalGlobe, GeoEye, Earthstar Geographics, CNES/Airbus DS, USDA, USGS, AEX, Getmapping, Aerogrid, IGN, IGP, swisstopo, and the GIS User Community
Esri, HERE, DeLorme, TomTom, MapmyIndia, © OpenStreetMap contributors, and the GIS user community

Table 8.1 provides a summary of the drainage area with land uses consisting of residential, commercial, transportation, and open space.

| Table 8.1 Rancho Park Drainage Area Land Use Summary Wastewater Facilities Plan One Water LA 2040 Plan | | |
|-----------------------------------------------------------------------------------------------------------------------|---------------------|---------------------------|
| Land Use | Area (acres) | Runoff Coefficient |
| Caltrans | 29 | 0.74 |
| Commercial/Institutional | 11 | 0.73 |
| Industrial | 53 | 0.74 |
| Open Space/Recreation | 200 | 0.12 |
| Residential | 98 | 0.39 |
| Total/Average | 394 | 0.35 |

Wet weather runoff volume from the entire 394-acre drainage area was estimated using guidelines outlined in the City's Low Impact Development (LID) BMP Handbook that meets the intent of the Standard Urban Storm Water Mitigation Plan (SUSMP) and LID Requirements of the Municipal Separate Storm Sewer System (MS4) permit. While the proposed project is not a New Development/Redevelopment project and therefore the LID/SUSMP requirements do not apply, they provide a potential target for consideration in sizing the project. The 85th percentile, 24-hour rainfall is estimated to be 1.15 inches in the Rancho Park area. Wet weather runoff volume is estimated based on drainage area, land use, and rainfall depth (Equation 1).

$$\text{Wet Weather Runoff Volume} = C \times D \times A \text{ (Equation 1)}$$

$$\text{Runoff Volume} = 0.35 \times 1.15 \text{ inches} \times 394 \text{ acres} = 13.1 \text{ AF}$$

Where,

C = area-weighted runoff coefficient of the upstream tributary areas classified by land use

D = storm event rainfall depth

A = the tributary drainage area

The estimated wet weather runoff volume generated by a single 1.15-inch storm event combined with the land use analysis performed for the drainage area, which yielded a composite imperviousness (*C*) of 0.35, is approximately 13.1 AF or 4.3 MG. A larger design storm could potentially be assumed so that a greater volume of stormwater may be captured and treated (e.g., a 95th percentile, 24-hour rainfall of 2.23 inches would result in approximately 8.1 MG of wet weather runoff), however, this would nearly double the cost and footprint requirements, which is not economical given the infrequent occurrence of such a large storm event. It is important to note that there is the potential for stormwater attenuation and temporary storage in the stormwater collection system, but for the purposes

of this evaluation it has been assumed that the entire 85th percentile storm volume of 4.3 MG would be captured and stored in an on-site storage tank prior to treatment and distribution. Since stormwater attenuation in the collection system may result in a smaller storage tank, stormwater attenuation should be further evaluated during preliminary design to verify the required volume for the raw stormwater storage tank.

If Component 1 could capture all runoff from all 85th percentile storm events, on a long-term average approximately 125 AF of runoff would be treated annually. If all dry weather runoff from the watershed is also captured, the annual yield could be approximately 170 AF, which is slightly over 35 percent of the annual average irrigation demand for the golf course and recreation center (470 AF).

8.3.1.2 Wastewater Supply for Components 2 and 3

The satellite WRP concept proposed to be implemented in Components 2 and 3, would require source water from the local wastewater collection system. The nearest primary sewer in the Rancho Park area that has adequate average daily flows to meet the non-potable reuse demand criteria is the Westwood Relief Sewer that originates downstream of UCLA (and runs southerly along Manning Avenue). Flow monitoring gauge data taken every 15 minutes was provided by the City and indicates an average dry weather flow rate of 6.13 mgd. The flows at each time of day from April 1 to December 31, 2015 were averaged over the 275-day period to produce an average diurnal curve. Figure 8.2 shows the average diurnal curve for gauge #51906144 located at the intersection of Manning Avenue and Mississippi Avenue. The diurnal curve shows that the wastewater flow rate fluctuates between slightly below 3 mgd between midnight and 7 a.m., to a peak of 8.8 mgd in mid-morning.

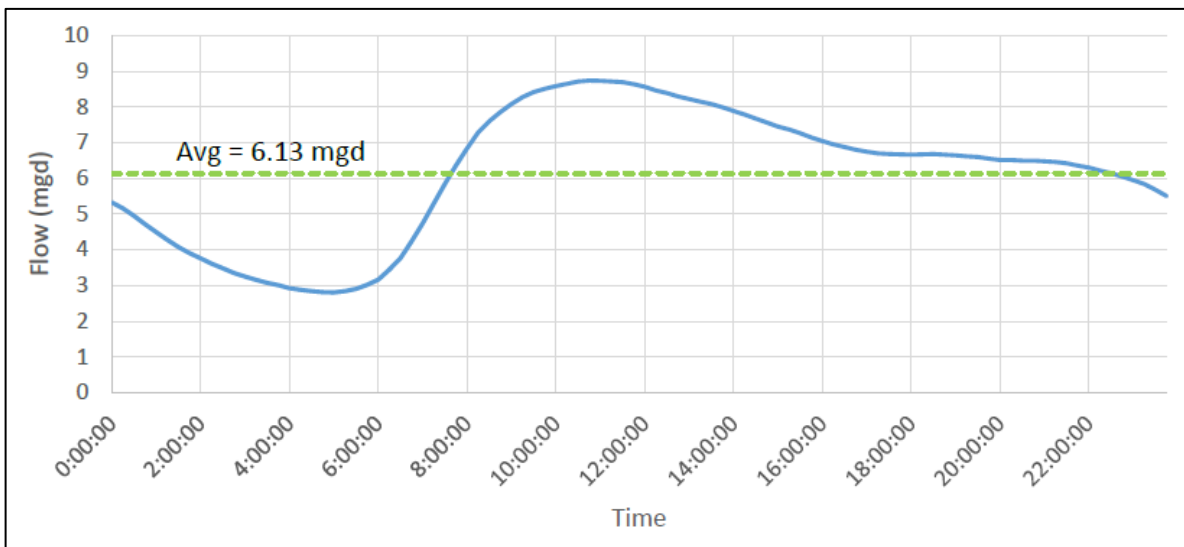

Figure 8.2 Average Diurnal Curve at WRS Gauge #51906144

BIOSOLIDS MANAGEMENT

In providing a sustainable 20-year planning strategy for the City, the Water IRP evaluated biosolids markets, assessed applicable technologies, and reviewed biosolids management approaches that may be suitable to the City.

This section provides an update to the Water IRP, specifically to the following subsections:

- Importance of Considering Biosolids in Water IRP and One Water LA Plan
- Existing Biosolids Management
- Solids Production
- Drivers Affecting Biosolids Management
- Future Biosolids Management
- Biosolids Technologies

9.1 IMPORTANCE OF CONSIDERING BIOSOLIDS IN WATER IRP AND ONE WATER LA

Biosolids processing at a WRP is integral to the achievement of regulatory compliance for effluent quality, solids diversion/reuse, and air emissions. In recent years, regulatory drivers and public perception have further accentuated the importance of the biosolids processing component of wastewater management to successful system operation. The City is one of the largest wastewater treatment agencies in Southern California and as such the management of biosolids is critical. Biosolids produced at HWRP or TIWRP are 100 percent beneficially reused. The biosolids management approaches currently being utilized are land application, compost, and deep well injection.

Potential changes in biosolids management need to be further studied and reviewed in the development of any long-term plan to assist the City in developing a portfolio of effective options in both the near-term and long-term. This diverse portfolio incorporates flexibility to adjust to future changing conditions.

9.2 EXISTING BIOSOLIDS MANAGEMENT

LAGWRP and DCTWRP do not have solids handling facilities, instead both facilities convey solids to the HWRP. HWRP and TIWRP have onsite systems to process biosolids and facilitate their beneficial reuse. TIWRP has changed from land applying Class A biosolids cake at a site in Maricopa County, Arizona to utilizing the TIRE demonstration project for 100 percent of the biosolids produced at TIWRP along with a portion of the biosolids from HWRP. HWRP land applies Class A biosolids to the Green Acres Farm (GAF). Both plants

meet quality requirements dictated by regulatory standards for the respective approaches to biosolids reuse/diversion.

The current biosolids operations at HWRP and TIWRP both provide economically favorable approaches while achieving regulatory compliance. A number of features that contribute to the cost effective management practices include, listed per plant:

TIWRP

- The TIRE Demonstration program eliminates cost associated with dewatering.
- Onsite biosolids diversion eliminates transportation costs and additional costs previously incurred for land application.

HWRP

- Egg-shaped digesters reduce maintenance costs and mixing energy requirement
- Thermophilic digestion increases gas production and creates a Class A product
- High solids centrifuges reduce the moisture content of the biosolids cake and thereby minimize transportation costs
- Land application has proved economic and agriculturally beneficial

9.3 SOLIDS PRODUCTION

LASAN effectively and efficiently manages and reuses the biosolids produced at HWRP and TIWRP. GAF receives 62.7 percent of HWRP's biosolids. Land applying at GAF represents the most cost effective approach in LASAN's diverse biosolids management portfolio, due to the farm revenue offsetting the farm management cost. In addition to land application at GAF, biosolids from HWRP are land applied at a site in Yuma, Arizona as well as composting by Griffith Park Compost Facility (GPCF), South Kern Compost (SKC), and Nursery Products (NP) composting, while 15.9 percent of the biosolids are utilized in TIRE. The percent of biosolids distributed to each site and the average wet tons per year received by each site is compiled in Table 9.1.

| Table 9.1 Biosolids Distribution Wastewater Facilities Plan One Water LA 2040 Plan | | |
|---------------------------------------------------------------------------------------------------|---------------------------------------------|--------------------------------------|
| Site | % Biosolids Distribution by Site | Average Wet Tons per Year |
| GPCF | 0.4% | 955 |
| GAF | 62.7% | 149,734 |
| SKC | 0.7% | 1,672 |

| Table 9.1 Biosolids Distribution Wastewater Facilities Plan One Water LA 2040 Plan | | |
|---------------------------------------------------------------------------------------------------|----------------------------------|---------------------------|
| Site | % Biosolids Distribution by Site | Average Wet Tons per Year |
| NP | 9.8% | 23,403 |
| Yuma | 10.8% | 25,792 |
| TIRE (HWRP) | 15.9% | 37,971 |
| TIRE (TIWRP) | 100% | 13,374 |

Over the past ten years, the percent total solids (%TS) of the biosolids produced at TIWRP has maintained relative uniformity since the biosolids do not undergo dewatering. Figure 9.1 shows the biosolids trend for wet tons, dry tons, and percent total solids per year from 2006 to 2016 at TIWRP.

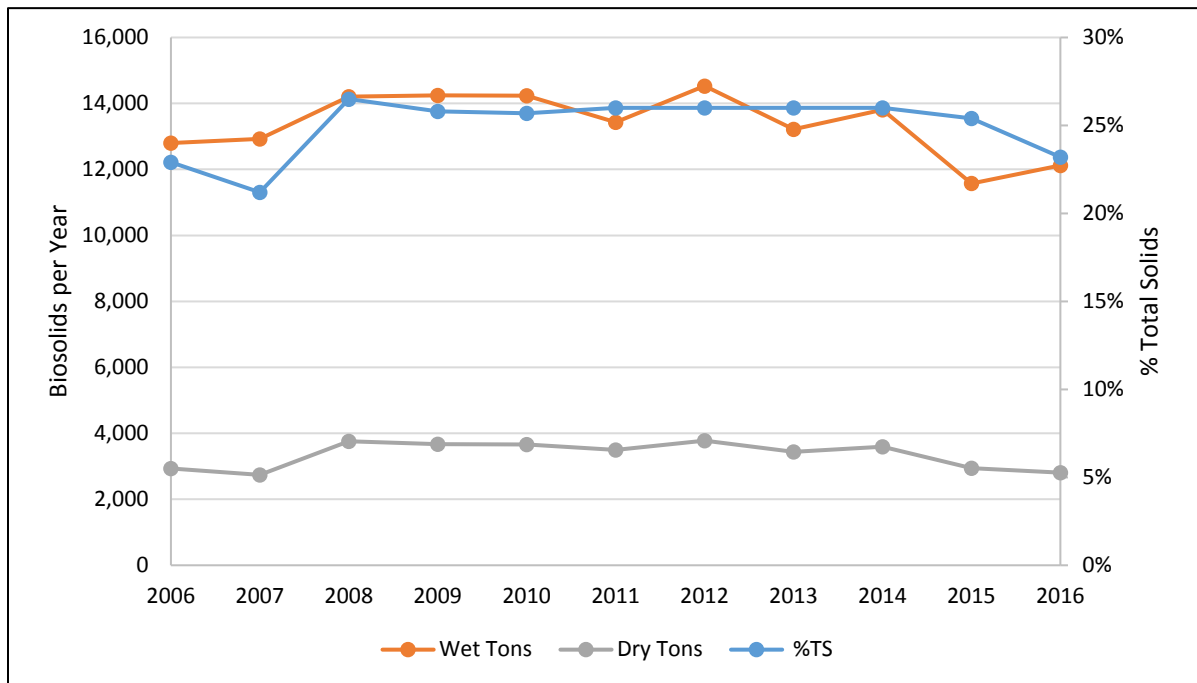

Figure 9.1 Trend in Biosolids at TIWRP from 2006 through 2016

Figure 9.1 demonstrates how the yearly biosolids mass and concentration has remained steady over the 10-year period from 2006 to 2016 with minor variations. In the case that TIWRP does have variability in its biosolids mass and concentration, TIRE is adaptable to reasonable changes in the percent total solids. TIRE also receives biosolids from HWRP. The %TS at TIWRP is for the limited times when wetcake is produced. The majority of the biosolids produced at TIWRP are injected into TIRE as digested solids.

Over the past ten years, the HWRP has seen the mass of biosolids (as expressed by dry tons) remain relatively constant while during the same period there has been an overall

increase in the wet tons of biosolids produced in the plant and a decrease in the percent total solids. The wet tons have increased by 37,000 wet tons per year between 2006 and 2016. Figure 9.2 shows the biosolids trend for wet tons, dry tons, and percent total solids per year from 2006 to 2016.

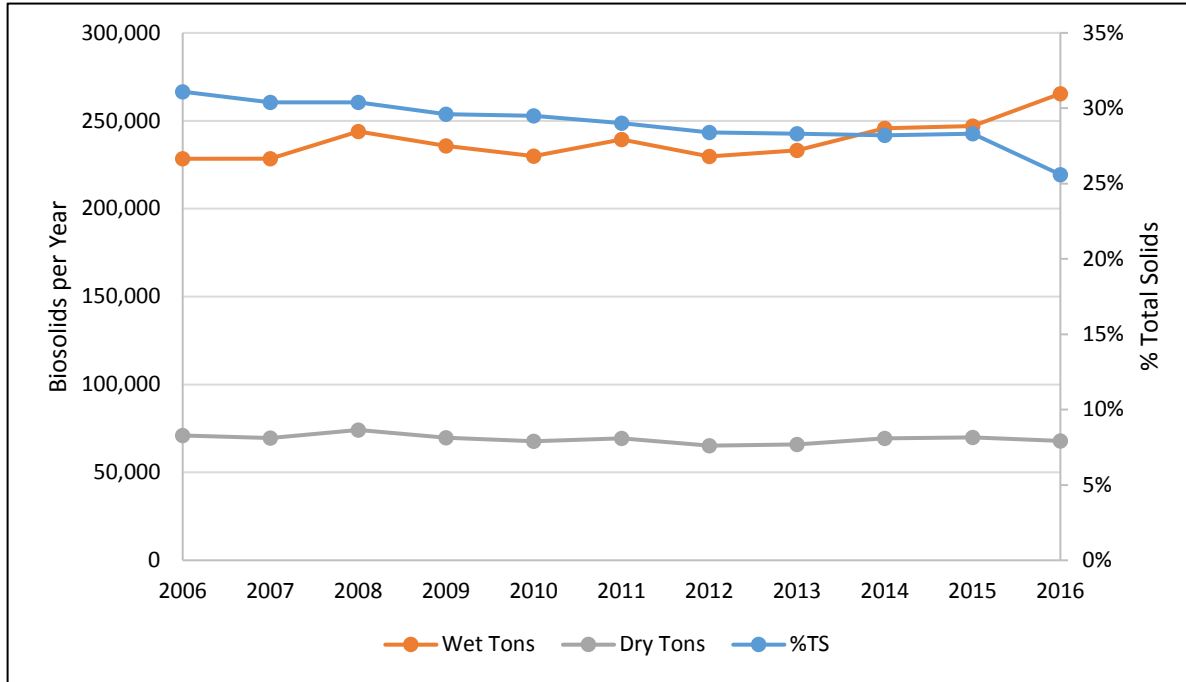

Figure 9.2 Trend in Biosolids at HWRP from 2006 through 2016

The decrease in percent total solids causes an increase in wet tonnage of biosolids. This directly increases the cost to manage the biosolids – a cost that could be reduced with optimization of the centrifuges.

LASAN manages a large amount of biosolids each year. HWRP and TIWRP produced a yearly average around 239,000 and 13,000 wet tons of biosolids, respectively, and the mass of biosolids may increase with the addition of food waste. It is important for LASAN to consider the drivers that may impact the disposal and reuse of biosolids produced in the future. The data that was used to generate the tables and graphs below is located in Appendix F.

9.4 DRIVERS AFFECTING BIOSOLIDS MANAGEMENT

The previous Wastewater Facilities Plan in the Water IRP identified three drivers that impact biosolids management – regulations, public perception, and product market options. Since 2006, these drivers have largely remained unchanged. The driver that could potentially impact solids management the most in the future is regulations and the potentially more stringent limits being imposed. Currently, the City is in full compliance with the requirements set forth in federal regulation, 40 Code of Federal Regulations (CFR) Part 503, commonly referred to as the "503 regs".

Currently, solids handling at TIWRP is completed using the TIRE demonstration program. Through TIRE stabilized solids are conveyed into deep underground fracture zones through high pressure injection wells. The TIRE is a unique, innovative approach to biosolid reuse with the added benefits of greenhouse gas sequestration and it is a local reuse option. The project is permitted through EPA as a demonstration project. In discussions with plant staff and permitting authorities, the current permit will expire in December of 2018; however, it is anticipated the demonstration permit will continue to be renewed every five years. LASAN applies for each permit 18 months before the permit expires. If the EPA does not issue a permit before the expiration date, a letter will be issued allowing a temporary extension under the current permit until the new permit is approved or denied. The EPA decides whether to issue either a 5-year or 10-year permit. In this case, 5-year permits have been issued. It is not known how long the EPA will continue to issue the 5-year demonstration permits. In the instance that the permit is not renewed, the project will have to complete criteria as indicated by the permit for well plugging and abandonment. Staff at TIWRP will also have to investigate equipment at the plant to identify a reliable alternative solids handling process.

The majority of HWRP biosolids are currently being land applied at the City owned site called Green Acres Farm in Kern County, where the treated biosolids are tilled into the soil as fertilizer and soil amendment for use on crops, such as corn and wheat. Previously there had been concerns about whether the City could legally continue to land apply in Kern County. Kern County voter approved ordinance (Measure E) would have banned biosolids land application from any source in unincorporated portions of the county. This would essentially end the use of the Green Acres Farm for biosolids reuse. However in 2016, a judge ruled that state law preempts the Kern County "Measure E" and the City can continue using biosolids at Green Acres. In 2017 through negotiation a settlement agreement was reached among the parties of the lawsuit. LASAN will continue to conduct biosolid land application at Green Acres Farms.

9.5 FUTURE BIOSOLIDS MANAGEMENT

LASAN's Biosolids Management Program strives to maintain a diversified portfolio of biosolids reuse options. A diversified portfolio approach provides flexibility to adjust to new conditions and encourages responsible, cost effective, and sustainable future management practices. Creating a diversified portfolio would provide the flexibility needed to address future changes in regulations and potential legal challenges. This portfolio should consist of the present approaches of Green Acres and TIRE as well as options that include new proven technologies along with different geographic venues for diversion and reuse. LASAN's close monitoring and evaluation of developing technologies and potential applicable regulatory actions should be continued and encouraged.

The projection of future biosolids quantities has not been developed for this study. Increases in the quantity of raw solids, however, can be expected to roughly follow

projected system flow increases. HWRP will see increases that include growth in flows to the two upstream plants that return residuals to the collection system. In addition to increased residuals from the upstream plants, LASAN may see an increase in solids production from the potential addition of food waste into the conveyance system. The amount is currently unknown, but is being studied. Below is a description of the two ongoing projects.

In an effort to provide solutions for local businesses to comply with California State Assembly Bill 1826, LASAN is currently evaluating the processing of organics and food waste materials for renewable energy. There are two separate, but interrelated projects currently underway. The first would be to develop an Organics Processing Facility (OPF) at its Central Los Angeles Recycling and Transfer Station (CLARTS) site. This OPF would process organics and food waste received to produce a slurry that can be used to generate renewable energy at HWRP or a dedicated waste conversion digester facility. The goal of the CLARTS OPF is to provide receiving and processing capabilities for up to 300 tons per day of source-separated organic wastes that is expected to be received as part of compliance with the Zero Waste LA Exclusive Franchise System. CLARTS OPF will generate 140 tons per day of food waste.

The second ongoing project is to assess the impact of the CLARTS OPF project on the HWRP's operations. This study will examine the food waste characteristics and estimate impacts to liquid and solid process unit operations at the HWRP. Potential mitigation measures will be reviewed and evaluated for plant areas that are substantively impacted. The impact and quantity of solids production will be determined as part of this study.

9.6 INTRODUCTION AND PRE-SCREENING OF PRODUCT TECHNOLOGIES (BIOSOLIDS TECHNOLOGIES)

In the 2006 evaluation of alternative biosolids management strategies, the City focused on two key aspects – the biosolids markets and the processing technologies. This combines a business-type approach to cost-effectiveness coupled with technologies that are feasible for the biosolids treatment. In 2006, the number of markets that the City was considering consisted of 16 and the number of processing technologies exceeded 11.

Today, the City is using two markets and two technologies. At HWRP, Class A biosolids are produced using thermophilic digestion followed by dewatering for land application at Green Acres. At TIWRP, Class A biosolids are produced using thermophilic digestion prior to deep-well injection. Other categories of technologies that could be utilized to expand the City's biosolids management portfolio include heat drying, chemical treatment, combustion, super critical water oxidation, gasification, pyrolysis and thermal hydrolysis. These categories of technologies are described and summarized in Table 9.2. The information presented builds from the information in the 2006 Water IRP and presents technologies that are favorable specifically to the City.

| Table 9.2 Projected Wastewater Flows Wastewater Facilities Plan One Water LA 2040 Plan | | |
|-------------------------------------------------------------------------------------------------------|-------------------------------------------------------------------------------------------------------------------------------------------------------------|----------------------------------------------------------------------------------------------------------------------------------|
| Category | Function | End product |
| Heat drying | Uses heat to reduce the volume and mass and biosolids by removing water. | Produces Class A biosolids. |
| Chemical treatment | Stabilization of the solids using an alkali process, such as lime, fly ash, or sulfuric acid, or fortifying the biosolids with chemicals. | Stable sludge product for land application to increase soil pH or high end fertilizer. |
| Complete Combustion | Adds oxygen and heat at a minimum of 1,400°F to oxidize the remaining organics in the biosolids. | Ash with no value. |
| Supercritical water oxidation | Adds oxygen, heat, and pressure at super critical values (700-1,100°F and 3,200 to 4,000 psi for water) to oxidize the biosolids. | Ash with no value. |
| Gasification | Adds heat to convert any biosolid material into gas | Gas, sometimes tar or char with low value. |
| Pyrolysis | Adds heat and pressure while removing oxygen to crack the biosolids. Heat can range from 600°F to 1800°F while pressure can range from 0-3,000 psi. | At mid temperature pyrolysis: char with fuel value and oil that may have a heating value. At high temperature pyrolysis: ash. |
| Thermal hydrolysis | Apply heat and pressure to raw sludge to enhance biodegradability and thereby increase digestion capabilities, biogas production and improve dewaterability | Following thermal hydrolysis, biosolids would be digested and dewatered to produce a Class A biosolids |

9.7 RECOMMENDATIONS

LASAN currently manages and reuses the biosolids in a cost effective manner, through reuse at GAF and TIRE injection. In the case of HWRP, the centrifuges should be studied to optimize their performance to increase the percent total solids. In addition, other solids processing technologies should be studied and piloted with the aim of improving cake solids. With regard to diversion or reuse of the cake solids, LASAN could develop partnerships with other agencies with land application sites.

In the interest of further diversifying the biosolids management portfolio beyond land application, composting, and deep-well injection, it is recommended to engage in studies to evaluate the following three options due to their valuable end products:

- Heat drying to produce fertilizer pellets
- Chemical treatment using fly ash or lime to produce a soil amendment for increasing the pH or potentially producing a high-end fertilizer
- Thermal hydrolysis to determine benefits (digester capacity, biogas, etc.) versus costs and system complexity

Each of these options presents an opportunity for generating a revenue/savings to offset the costs of biosolids management, or perhaps the power costs at HWRP.

CLIMATE RISK AND RESILIENCE ASSESSMENT FOR WASTEWATER INFRASTRUCTURE

Projected changes in climate and hydrologic conditions have the potential to impact the City's wastewater and stormwater infrastructure and operations. Climate and hydrologic trends and threats have been identified via reviewing past and ongoing national, regional, and local studies and projects. The review was a literature search and compilation of case studies and federal, state, regional, and local efforts and documents. Volume 6 provides a detailed description of historical and potential future climate conditions and summaries of previous and ongoing climate change assessments. Appendices within Volume 6 provides summaries of previous City of Los Angeles climate change vulnerability assessments and climate adaptation planning efforts, respectively. Current and potential climatic conditions that were used to perform risk assessments are summarized herein. The first step was to identify the baseline conditions for assessing threats and risks within the City, which are:

- Temperature Increase
- High Winds
- Precipitation
- Sea Level Rise
- Earthquake
- Tsunami

Historical Climate Conditions

The climate of southern California and Los Angeles has been noticeably changing in recent times. Temperatures have increased in the South Coast Region (Santa Barbara, Los Angeles, Orange County, and San Diego) by about 0.45 degrees Fahrenheit (°F) (0.25 degrees Celsius [°C]) in the past decade, while 2014, 2015 and 2016 were the three warmest calendar years on record since 1895. And while trends in precipitation are difficult to discern due to natural variability (the wettest year and the driest year on record since 1895 have both occurred since 1980), there has been a downward trend in annual precipitation since 1995 and below-average annual precipitation from 2011 to 2016.

Sea levels have steadily risen over the past century, although not at a consistent rate along the coastal Los Angeles region for a variety of factors. Relative sea levels rise and fall based on ocean and coastal conditions as affected by sea conditions, circulation patterns, land subsidence and uplift, seismic events, and other factors. Mean sea level at the Los Angeles and Santa Monica tide stations has increased by about 0.33 foot (0.10 meter) to 0.49 foot (0.15 meter) over the past century.

Potential Future Climate Conditions

Future changes to the global climate system are expected to cause changes in the Los Angeles hydroclimate over the next century. Average air temperature is projected to increase from 3.2°F (1.8°C) to 3.6°F (2.0°C) by 2050. By continuing existing emission patterns, average temperatures will raise outside of normal variability to create a new regional climate by the end of century. These changes will result in increasing the frequency of extremely hot days (greater than 95°F or 35°C) from 6 to 22 days by 2050.

While it is difficult to discern strong trends from the full range of climate projections, the median of the projections suggest no change in the future annual precipitation. Despite the relative uncertainty in annual precipitation changes, about two-thirds of the projections suggest increases in 3 day annual maximum precipitation by end of century. The median change in 3 day annual maximum precipitation for the Los Angeles Downtown area by end of century is projected to increase by about 10 percent. The wetter projections also suggest an increase in the daily extreme precipitation events such as the 100-year/24-hour storm that would occur approximately 1 percent of the time on an annual basis, and the 10-year/24-hour storm used for stormwater and sewer design. The 10-year/24-hour storm is projected to have a 17 percent increase in volume and a higher hourly peak intensity by the year 2050. The frequency and severity of droughts are expected to increase under future climate.

Mean sea level at Los Angeles, due to thermal expansion, ice melt, and local vertical land movement, is projected to increase by a range of 0.43 to 1.97 feet (0.13 to 0.6 meter) by 2050 and 1.44 to 5.45 feet (0.44 to 1.66 meter) by 2100 relative to 2000.

Current and Climate Change Conditions Applied to Risk Assessments

Historical, current, and potential climate-based threats and risks are described above and in detail in Volume 6. The future conditions of the potential climate-based threats affect particular risks such as flooding, erosion, landslides, wildfire, and power outages. This information was used as the basis to select baseline and projected climate threat conditions for risk assessments and resilience planning. Table 10.1 lists the baseline conditions for assessing current (baseline) threats/risks and the mid-century (year 2060) projected values for assessing future threats/risks with climate change. Temperature, the number of hot days, precipitation, and extreme storm events (100-year/24-hour storm) vary by location from coastal to inland areas of Los Angeles and are therefore location-based for baseline and projected future conditions. In addition to what is shown in the table for sea level rise (SLR), an overall SLR of 4.92 feet (1.5 meters) was also considered for year 2100 conditions.

| Table 10.1 Climate Change Conditions Used in Risk Assessments and Resilience Planning Wastewater Facilities Plan One Water LA 2040 Plan | | |
|------------------------------------------------------------------------------------------------------------------------------------------------|-----------------------------------------|-------------------------------------------------------------|
| Climate Variable | Baseline Condition | Projected Value for Mid-Century (Observed + Changes) |
| Annual Temperature | Location Based (~63°F) | +3°F to +4°F |
| Number of Hot Days (over 95°F) | 6 | 22 |
| Total Annual Precipitation | Location Based (14 to 18 inches/year) | -10.7% to +11.2% |
| 100-Year/24-Hour Storm Event | Location Based (5 to 7 inches/24 hours) | +34.3% |
| Sea-Level Rise | 0.06-0.09 inch/year | 1.64 feet (0.5 meter) |

10.1 METHODOLOGY

Climate change is projected to impact the City's wastewater and stormwater systems in a variety of ways. The wastewater systems consist of sewer systems, sewage pumping facilities, wastewater treatment facilities and water reclamation facilities. The stormwater systems consist of collection systems, stormwater pumping plants, watershed protection, and Proposition O projects. Changes in temperature, precipitation, and sea levels will affect the physical plant and operational vulnerabilities of these facilities and operations.

A climate risk and resilience assessment was performed consisting of scenario development, screening analyses, site visits, risk analyses, and adaptation planning concurrent with ongoing meetings with LASAN staff. The assessments were performed for a total of 81 facilities including water reclamation plants, wastewater and stormwater pumping plants, LFD, and facilities currently in design. Current and potential future climate conditions were considered to perform the assessments and develop recommendations. This section describes the assessment approach, existing resilience measures employed by the City, and the assessments of facilities with recommendations for improving resilience.

10.2 PUMPING PLANT AND LOW FLOW DIVERSIONS ASSESSMENT

The City owns and operates 77 wastewater and stormwater pumping plants, and LFD. Each of these facilities was screened and assessed for existing and potential future climate hazards and the associated risks. This section summarizes the current and/or future risks, damage replacement costs associated with the risks, resilience improvement recommendations, and costs. A more detailed summary of each facility is included in Volume 6.

10.2.1 Wastewater Pumping Plants

There are 43 wastewater pumping plants including 23 in the HWRP collection system and 20 in the TIWRP collection system. The pumping plant capacities range from 20 gpm to 45,000 gpm. Table 10.2 lists the pumping plants by number, name, pumping capacity, and the risk assessment finding (none, minimal risk requiring no action, at risk requiring action).

| Plant No. | Name | Capacity (gpm) | Risk Assessment Finding |
|------------------|-------------------------|-----------------------|--------------------------------|
| 601 | Manchester | 20,160 | None |
| 602 | Union Pacific | 4,600 | None |
| 604 | Highbury | 2,250 | None |
| 605 | San Pasqual | 30 | None |
| 606 | Dacotah | 10,000 | None |
| 608 | Washington & Industrial | 100 | None |
| 610 | 11th & Santa Fe | 2,000 | None |
| 611 | Riverdale | N/A ⁽¹⁾ | At Risk |
| 616 | Cahuenga | 1,600 | None |
| 624 | Roscomare | 500 | At Risk |
| 626 | Riverdale | 80 | None |
| 628 | Corbin | 400 | At Risk |
| 631 | Hamden Place | 110 | None |
| 632 | Sunset | 10,000 | Minimal Risk |
| 633 | Chautauqua | 300 | Minimal Risk |
| 634 | Temescal | 4,500 | At Risk |
| 638 | Palisades | 600 | At Risk |
| 639 | North Pulga | 3,000 | At Risk |
| 646 | Venice Pumping Plant | 45,000 | At Risk |
| 648 | Thompson | 700 | At Risk |
| 649 | Jefferson | 190 | At Risk |
| 654 | Ballona Creek | 18,000 | None |
| 659 | Nors | 20 | None |
| 666 | Fries Ave. | 7,400 | At Risk |
| 668 | Henry Ford | 6,800 | At Risk |
| 669 | Harris Place | 1,600 | At Risk |
| 671 | Terminal Way | 10,000 | At Risk |
| 672 | Murdock & "I" | 1,100 | At Risk |

| Table 10.2 Wastewater Pumping Plants Wastewater Facilities Plan One Water LA 2040 Plan | | | |
|-------------------------------------------------------------------------------------------------------|-------------------|-----------------------|--------------------------------|
| Plant No. | Name | Capacity (gpm) | Risk Assessment Finding |
| 674 | 190th & Vermont | 2,800 | None |
| 675 | P.C.H. & Figueroa | 1,200 | None |
| 676 | McFarland | 8,000 | At Risk |
| 677 | Hawaiian & "B" | 5,800 | At Risk |
| 680 | 22nd & Signal | 100 | At Risk |
| 681 | Ports 'O' Call | 300 | At Risk |
| 683 | 22nd Street | 900 | At Risk |
| 684 | Miner | 500 | At Risk |
| 685 | Signal | 200 | At Risk |
| 686 | Nissan Way | 1,700 | At Risk |
| 687 | North Neptune | 880 | At Risk |
| 688 | South Neptune | 700 | None |
| 689 | Seaside | 1,000 | At Risk |
| 690 | Anchorage | 520 | At Risk |
| 691 | San Pedro | 18,000 | At Risk |
| <u>Note:</u> (1) No pump, bladder storage pumped out with tanker truck. | | | |

The following is a summary of the risk assessment of 26 wastewater pump stations that were determined to have greater than minimal identified threats, the recommended resilience improvements, the estimated cleaning and replacement costs of damaged or destroyed assets at the facility should the identified risks occur, and the estimated capital costs of implementing the recommended resilience improvements.

Riverdale Pumping Plant No. 611 is at risk of inundation during the 100-year and 500-year flood events. The recommended resilience improvements are to waterproof instrumentation and controls. The estimated damage replacement cost of the facility is \$21,060 (there are no pumps or controls; therefore, the assumed minimum replace-in-kind cost does not apply) and the estimated resilience improvements cost is \$50,000. Considering the estimated resilience improvement cost exceeds the replace-in-kind cost, and that the station is actually a storage and pump-out station, no improvement is recommended at this time.

Roscomare Pumping Plant No. 624 is at risk of landslide and wildfire. The recommended resilience improvements are to increase the height of the existing retaining wall behind the facility and manage nearby vegetation to minimize fire risk. The estimated damage replacement costs of the facility is \$1,000,000 and the estimated resilience improvements cost is \$20,000.

Corbin Pumping Plant No. 628 is at risk for wildfire. The recommended resilience improvement is to manage the nearby vegetation to minimize fire risk. The estimated damage replacement cost of the facility is \$1,000,000, and there is no capital cost for the recommended resilience improvements.

Temescal Pumping Plant No. 634 is at risk of landslide and wildfire. The recommended resilience improvements are to improve an existing wall at the facility to protect the facility from landslides and fire, and to manage the nearby vegetation. The estimated damage replacement costs of the facility is \$3,159,000, and the estimated resilience improvements cost is \$60,000.

Palisades Pumping Plant No. 638 is at risk for wildfire. The recommended resilience improvement is to manage the nearby vegetation to minimize fire risk. The estimated damage replacement cost of the facility is \$1,000,000, and there is no capital cost for the recommended resilience improvements.

North Pulga Pumping Station No. 639 is at risk of landslide and wildfire. The recommended resilience improvements are to construct a wall around the facility to protect landslide and fire and to manage the nearby vegetation. The estimated damage replacement cost of the facility is \$2,106,000, and the estimated resilience improvements cost is \$60,000.

Venice Pumping Plant No. 646 is at risk of inundation during 500-year flood and tsunami events. The recommended resilience improvements are to waterproof the building, install watertight connections, and move the portable generator kept on site to higher ground. The estimated damage replacement cost of the facility is \$31,590,000, and the estimated resilience improvements cost is \$1,600,000.

Thompson Pumping Plant No. 648 is at risk of inundation during 500-year flood and tsunami events. The recommended resilience improvements are to waterproof the building, waterproof hatches, install watertight connections, and raise the portable generator to a higher elevation. The estimated damage replacement cost of the facility is \$1,000,000, and the estimated resilience improvements cost is \$480,000.

Jefferson Pumping Plant No. 649 is at risk of inundation during the 500-year flood event. The recommended resilience improvements are to waterproof instrumentation and controls. The estimated damage replacement cost of the facility is \$1,000,000, and the estimated resilience improvements cost is \$80,000.

Fries Pumping Plant No. 666 is at risk of inundation during a 100-year flood with 0.5 meter of SLR, a 500-year flood, and tsunami events. The recommended resilience improvements are to raise the generator pad, install watertight connections, waterproof the structure and interior instrumentation and controls to maintain its historical status, waterproof exterior hatches, and construct a flood wall with flood gates around the pump station building. The estimated damage replacement cost of the facility is \$5,194,800, and the estimated resilience improvements cost is \$1,110,000.

Henry Ford Pumping Plant No. 668 is at risk of inundation during the 100- and 500-year flood, a 100-year flood with 0.5 meter of SLR, and tsunami events. The recommended resilience improvements are to raise the generator pad and waterproof the building. The estimated damage replacement cost of the facility is \$4,743,600, and the estimated resilience improvements cost is \$230,000.

Harris Pumping Plant No. 669 is at risk of inundation during a tsunami event. The recommended resilience improvements are to raise the generator pad, waterproof the structure or interior instrumentation and controls to maintain its historical status, waterproof exterior hatches, and construct flood wall with gates around the pump station. The estimated damage replacement costs of the facility is \$1,123,200, and the estimated resilience improvements cost is \$810,000.

Terminal Way Pumping Plant No. 671 is at risk of inundation during the 500-year flood, a 100-year flood with 1.5 meters of SLR and tsunami events. The recommended resilience improvements are to raise the generator pad, install watertight connections, protect motor control centers, waterproof instrumentation and controls and hatches, raise vents, waterproof building, and install bollards to protect above ground structures from tsunami wave debris. The estimated damage replacement cost of the facility is \$7,020,000, and the estimated resilience improvements cost is \$1,070,000.

Murdock & "I" Pumping Plant No. 672 is at risk of inundation during a 100-year flood with a 1.5 meters of SLR and tsunami events. The recommended resilience improvements are to raise the generator pad, install watertight connections, protect motor control centers, waterproof instrumentation and controls and hatches, raise vents, waterproof building, and install bollards to protect above ground structures from tsunami wave debris. The estimated damage replacement cost of the facility is \$1,000,000, and the estimated resilience improvements cost is \$720,000.

McFarland Pumping Plant No. 676 is at risk of inundation during the 500-year flood, a 100-year flood with 1.5 meters of SLR, and tsunami events. The recommended resilience improvements are to raise the generator pad, install watertight connections, protect motor control centers, waterproof instrumentation and controls and hatches, raise vents, waterproof building, and install bollards to protect above ground structures from tsunami wave debris. The estimated damage replacement cost of the facility is \$5,616,000, and the estimated resilience improvements cost is \$1,020,000.

Hawaiian & "B" Pumping Plant No. 677 is at risk of inundation during the 500-year flood, a 100-year flood with 1.5 meters of SLR, and tsunami events. The recommended resilience improvements are to raise the generator pad, install watertight connections, protect motor control centers, waterproof instrumentation and controls and hatches, raise vents, waterproof control room with submarine doors, and install bollards to protect above ground structures from tsunami wave debris. The estimated damage replacement cost of the facility is \$4,071,600, and the estimated resilience improvements cost is \$870,000.

22nd & Signal Pumping Plant No. 680 is at risk of inundation during the 500-year flood, a 100-year flood with 1.5 meters of SLR, and tsunami events. The facility was rehabilitated in 1997-1998 with a cost of \$566,000. The recommended resilience improvements are to install watertight connections, protect motor control centers, waterproof instrumentation and controls and hatches, raise vents, and seal holes in exterior walls of the structure. The estimated damage replacement cost of the facility is \$1,000,000, and the estimated resilience improvements cost is \$126,000.

Ports O' Call Pumping Plant No. 681 is at risk of inundation during the 500-year, a 100-year flood with 1.5 meters of SLR, and tsunami events. The recommended resilience improvements are to install watertight connections, protect motor control centers, waterproof instrumentation and controls, and install bollards around the facility to protect from tsunami wave debris. The estimated damage replacement cost of the facility is \$1,000,000, and the estimated resilience improvements cost is \$340,000.

22nd Street Pumping Plant No. 683 is at risk of being inundated during a tsunami event. The recommended resilience improvements are to install watertight connections, protect motor control centers, waterproof instrumentation and controls and hatches, raise vents, waterproof control room, and install bollards around the facility to protect from tsunami wave debris. The estimated damage replacement cost of the facility is \$1,000,000, and the estimated resilience improvements cost is \$500,000.

Miner Pumping Plant No. 684 is at risk of being inundated during a tsunami event. The recommended resilience improvements are to install watertight connections, protect motor control centers, waterproof instrumentation and controls and hatches, raise vents, waterproof control room, and install bollards around the facility to protect from tsunami wave debris. The estimated damage replacement cost of the facility is \$1,000,000, and the estimated resilience improvements cost is \$500,000.

Signal Pumping Plant No. 685 is at risk of inundation during the 500-year, a 100-year flood with 1.5 meters of SLR, and tsunami events. The recommended resilience improvements are to install watertight connections, protect motor control centers, waterproof instrumentation and controls and hatches, raise vents, waterproof control room, and install bollards around the facility to protect from tsunami wave debris. The estimated damage replacement cost of the facility is \$1,000,000, and the estimated resilience improvements cost is \$480,000.

Nissan Way Pumping Plant No. 686 is at risk of inundation during the 500-year, a 100-year flood with 1.5 meters of SLR, and tsunami events. The facility was replaced in 1997-1998 with a cost of \$419,000. The recommended resilience improvements are to install watertight connections, protect motor control centers, waterproof instrumentation and controls and hatches, raise vents, and install bollards around the facility to protect from tsunami wave debris. The estimated damage replacement cost of the facility is \$1,193,000, and the estimated resilience improvements cost is \$490,000.

North Neptune Pumping Plant No. 687 is at risk of inundation during the 500-year, a 100-year flood with 1.5 meters of SLR, and tsunami events. The recommended resilience improvements are to install watertight connections, protect motor control centers, waterproof instrumentation and controls and hatches, and install bollards to protect from tsunami wave debris. The estimated damage replacement cost of the facility is \$1,000,000, and the estimated resilience improvements cost is \$400,000.

Seaside Pumping Plant No. 689 is at risk of being inundated during a tsunami event. The recommended resilience improvements are to install watertight connections, protect motor control centers, waterproof instrumentation and controls and hatches, raise vents, waterproof control room with submarine doors, and install bollards to protect above-ground structures from tsunami wave debris. The estimated damage replacement cost of the facility is \$1,000,000, and the estimated resilience improvements cost is \$600,000.

Anchorage Pumping Plant No. 690 is at risk of inundation during the 500-year, a 100-year flood with 1.5 meters of SLR, and tsunami events. The recommended resilience improvements are to install watertight connections, protect motor control centers, waterproof instrumentation and controls and hatch, raise vent, and install bollards to protect from tsunami wave debris. The estimated damage replacement cost of the facility is \$1,000,000, and the estimated resilience improvements cost is \$300,000.

San Pedro Pumping Plant No. 691 is at risk of being inundated during a tsunami event. The recommended resilience improvements are to install watertight connections, protect motor control centers, waterproof instrumentation and controls and hatches, raise vents, waterproof control room, raise generator pad, and install bollards around the facility to protect from tsunami wave debris. The estimated damage replacement cost of the facility is \$12,636,000, and the estimated resilience improvements cost is \$1,080,000.

10.2.2 Low Flow Diversions

In order to enhance the water quality of the City's watersheds, mitigate pollutants found in stormwater, and meet Clean Water Act requirements of affected surface waters such as Santa Monica Bay, the City operates and maintains 20 LFD facilities that divert low, dry-weather runoff drainages to the sanitary sewer system, or treats it onsite for local water reuse applications. Kinney Circle Pumping Plant No. 647 is a 45,000 gpm stormwater pumping plant with a 500 gpm LFD - the assessment for that facility is given above with the stormwater pumping plants. The City-owned LFD facilities are shown in Table 10.3 with their pumping plant numbers, names, pumping capacities, and the risk assessment finding (none, minimal risk requiring no action, at risk requiring action).

| Table 10.3 City-Owned Low Flow Diversions Wastewater Facilities Plan One Water LA 2040 Plan | | | |
|------------------------------------------------------------------------------------------------------------|---------------------------|-------------------------------|--------------------------------|
| Plant No. | LFD Name | Pumping Capacity (gpm) | Risk Assessment Finding |
| 614 | Tuxford (LFD) | 180 | At Risk |
| 615 | Sun Valley Park | 80 | None |
| 647 | Kinney Circle (LFD) | 500 | At Risk |
| 701 | South LA Wetlands | 6,700 | Minimal Risk |
| 703 | Echo Park | 450 | Minimal Risk |
| 705 | Garvanza | 190 | None |
| 710 | 8th/Enterprise | 700 | None |
| 711 | Downtown | Conveyed by Gravity | None |
| 730 | Palisades Park | 1,480 | Minimal Risk |
| 732 | Marquez Canyon | 300 | Minimal Risk |
| 733 | Santa Monica | 10,000 | At Risk |
| 734 | Temescal | 3,500 | At Risk |
| 735 | Santa Monica Canyon (New) | 3,500 | None |
| 736 | Temescal Canyon | 3,500 | Minimal Risk |
| 739 | Bay Club Drive | 340 | Minimal Risk |
| 740 | Westside Park | 60 | At Risk |
| 741 | Mar Vista | 4,800 | None |
| 742 | Penmar | 2,700 | None |
| 747 | Thornton | 1,500 | Minimal Risk |
| 748 | Westminster Dog Park | Conveyed by Gravity | Minimal Risk |
| 750 | Imperial Hwy | 644 | None |
| ZOO | LA Zoo | 12,000 | At Risk |

The following is a summary of the risk assessment of five LFDs with identified threats, the recommended improvements to improve resilience, the estimated cleaning and replacement costs of damaged or destroyed assets at the facility should the identified risks occur, and the estimated capital costs of implementing the recommended resilience improvements.

Tuxford Pumping Plant No. 614 is at risk of inundation during the 100-year flood event. The recommended resilience improvements are to waterproof instrumentation and controls and hatches. The estimated damage replacement cost of the facility is \$650,000, and the estimated resilience improvements cost is \$90,000.

Santa Monica Pumping Plant No. 733 is at risk of inundation during the 500-year, a 100-year flood with 1.5 meters of SLR, and tsunami events. The recommended resilience improvements are to waterproof instrumentation and controls and hatches. The estimated damage replacement cost of the facility is \$1,300,000, and the estimated resilience improvements cost is \$140,000.

Temescal Pumping Plant No. 734 is at risk of landslide and wildfire. The recommended resilience improvements are to improve the wall around the facility to protect it from landslides and fire and to manage the nearby vegetation. The estimated damage replacement cost of the facility is \$650,000, and the estimated resilience improvements cost is \$60,000.

Westside Park Pumping Plant No. 740 is at risk of inundation from the 100- and 500-year flood events. The recommended resilience improvements are to waterproof instrumentation and controls and hatches. The estimated damage replacement cost of the facility is \$650,000, and the estimated resilience improvements cost is \$90,000.

Los Angeles Zoo Pumping Plant is at risk of inundation from the 100- and 500-year flood events. The recommended resilience improvements are to waterproof existing wall and install flood gates at both entrances, install influent and effluent gates to prevent flooding from within, waterproof control room, and raise its diesel fuel tank. The estimated damage replacement cost of the facility is \$8,424,000, and the estimated resilience improvements cost is \$960,000.

10.2.3 Improvements Summary and Prioritization

A total of 42 existing facilities (18 wastewater pumping plants, 9 stormwater pumping plants, and 15 LFDs) were determined to have no or minimal hazards. Facilities with no hazards were identified as such because they are not located in any of the hazard zones currently and in the future. A list with more detailed descriptions of facilities with minimal risks is provided in the appendices of Volume 6.

10.3 COLLECTION SYSTEM RISK AND RESILIENCE ASSESSMENT

The One Water LA 2040 Plan intends to analyze the impact of severe wet weather events caused by climate change on sewer sheds within the City of Los Angeles wastewater service area. Severe wet weather events produces storm events with pronounced peak intensities that can overwhelm the collection systems and impact the service areas by

flooding and related service disruptions. The One Water LA 2040 Plan has identified the Ballona Creek storm watershed as one of the areas that may be impacted by climate change-related extreme wet weather events. As such, the West Los Angeles Primary Sewer Basin, which lies within the Ballona Creek watershed, was selected to study potential hydraulic impacts related to climate change and increased storm intensities due to its historical occurrences of flooding and overflows, and the sensitivity of Ballona Creek.

10.3.1 West LA Primary Sewer Basin

The West Los Angeles (WLA) primary sewer basin falls in the vicinity of Ballona Creek storm watershed and its conveyance capacity was analyzed under current and modified design storm conditions representing potential future conditions. The limits of the West Los Angeles Primary Sewer Basin are defined by local drainage basins, also called secondary sewersheds. The West Los Angeles Basin contains thirty-eight secondary sewer basins and contains approximately 31 miles of primary sewers that range in size from 12 to 60 inches in diameter. Although primary sewers are typically greater than 15 inches in diameter, some pipes with diameters less than or equal to 15 inches may be included to maintain the continuity of the primary system. Figure 10.1 shows the configuration of primary sewers in the West Los Angeles Primary Sewer Basin.

10.3.2 Climate Change Scenario







Precipitation in most of California, including Los Angeles, is dominated by extreme variability, both seasonally, annually, and over decadal time scales. In general, projections of future climate over the United States suggest that the recent trend towards increased heavy precipitation events (5 percent in the Southwest) will continue. A discussion of potential future precipitation patterns is provided in Volume 6. Future design storm rainfalls are developed by applying downscaled calculations from general circulation models (GCM) of global climate change to local rainfall stations. A modified design storm is then calculated for future conditions.

The current City's 10-year/24-hour design storm was developed based on intensity, duration, and frequency (IDF) curves using a three-station average of historical mean precipitation data from the following rain stations:

- Los Angeles Civic Center
- Los Angeles International Airport
- City's 57A Rain Station

Figure 10.1
WLA Primary Sewer
Basin
 One Water LA 2040 Plan



-  WRP
-  Outfalls
-  Primary Sewer
-  Secondary Sewer
-  Contract Agency Sewer
-  WLA Primary Basin

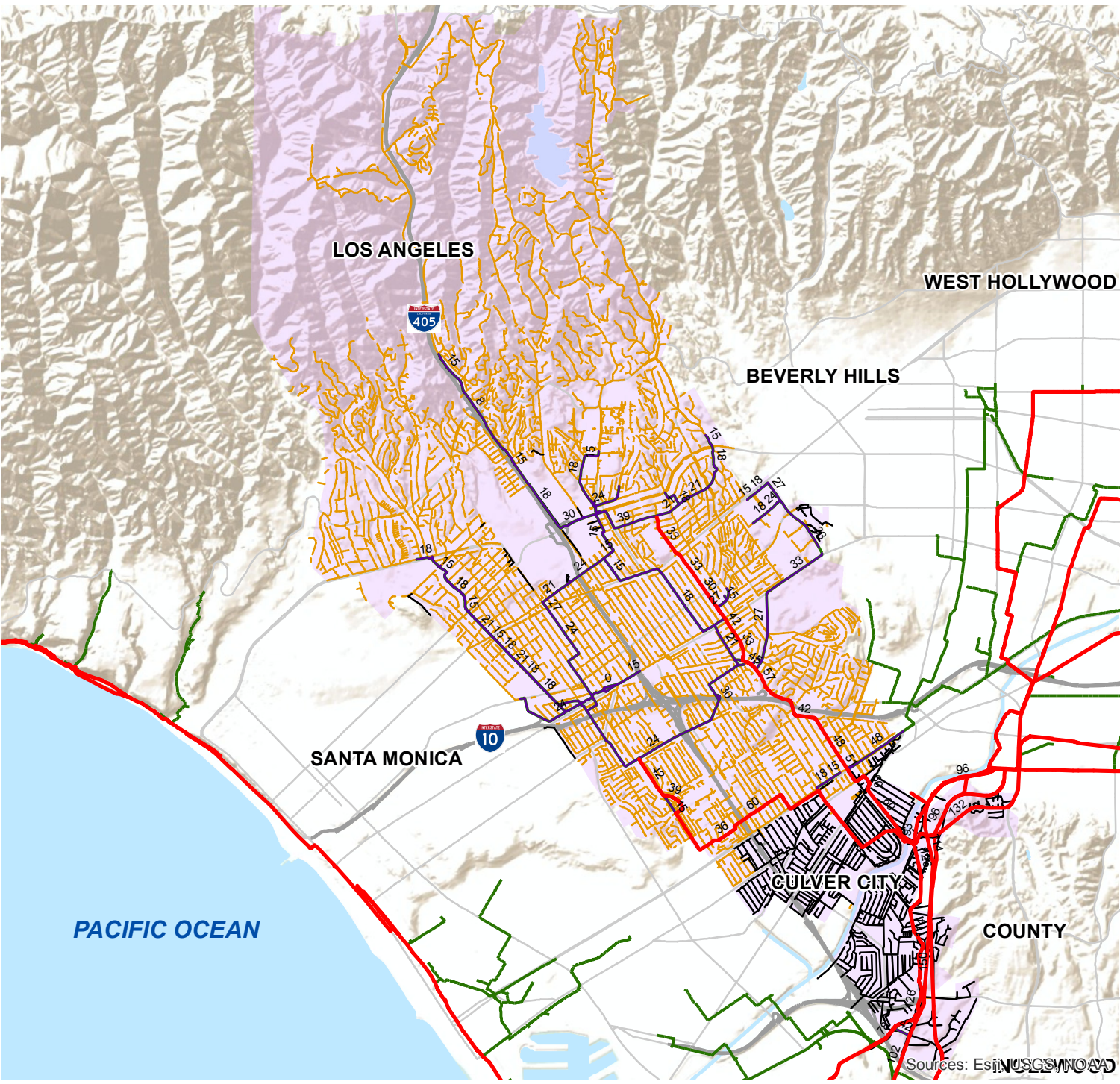

Sources: Esri, USGS, NOAA

The City's 57A Rain Station is in the San Fernando Valley and is not as representative of the conditions further south such as in the TISA. Precipitation data from the Torrance Airport rain station more accurately represent the climatological condition of the Venice and San Pedro Areas. For the purpose of this assessment, the precipitation data from the following local rain stations were used to modify design storms to reflect the effects of climate change:

- Los Angeles Civic Center
- Los Angeles International Airport
- Torrance Airport

Using the SimCLIM tool developed by CLIMsystems in Hamilton, New Zealand, climate change correction factors were computed for each station to adjust various design storms. SimCLIM is a tool to examine the spatial effects of climate variability at various target years and develop scenarios. It integrates historical observations with GCM calculations to develop climate scenarios at target years in the future. The correction factors are based on the CMIP5, RCP8.5 scenario, which is a higher trajectory for projected greenhouse gas concentrations in the latest climate change modeling efforts. Mean climate change correction factors for the three local stations were used to develop a modified design storm for the year 2050.

The total rainfall volume of the modified design storm represents a 17 percent increase over historical values. The cumulative rainfall produced in the twenty-four period is about 4.44 inches for the current design storm and 5.21 inches for the modified design storm. The modified design storm has a peak intensity of 1.34 inches compared to the peak intensity of 1.14 inches for the current storm as shown in Figure 10.2 of the current and modified design storm hyetographs.

The peak intensities observed under the climate change scenarios are higher than the ten year design storm by about 0.2 inch per hour. The modified design storm produces higher runoff from the catchment area and RDI/I into the wastewater collection systems.

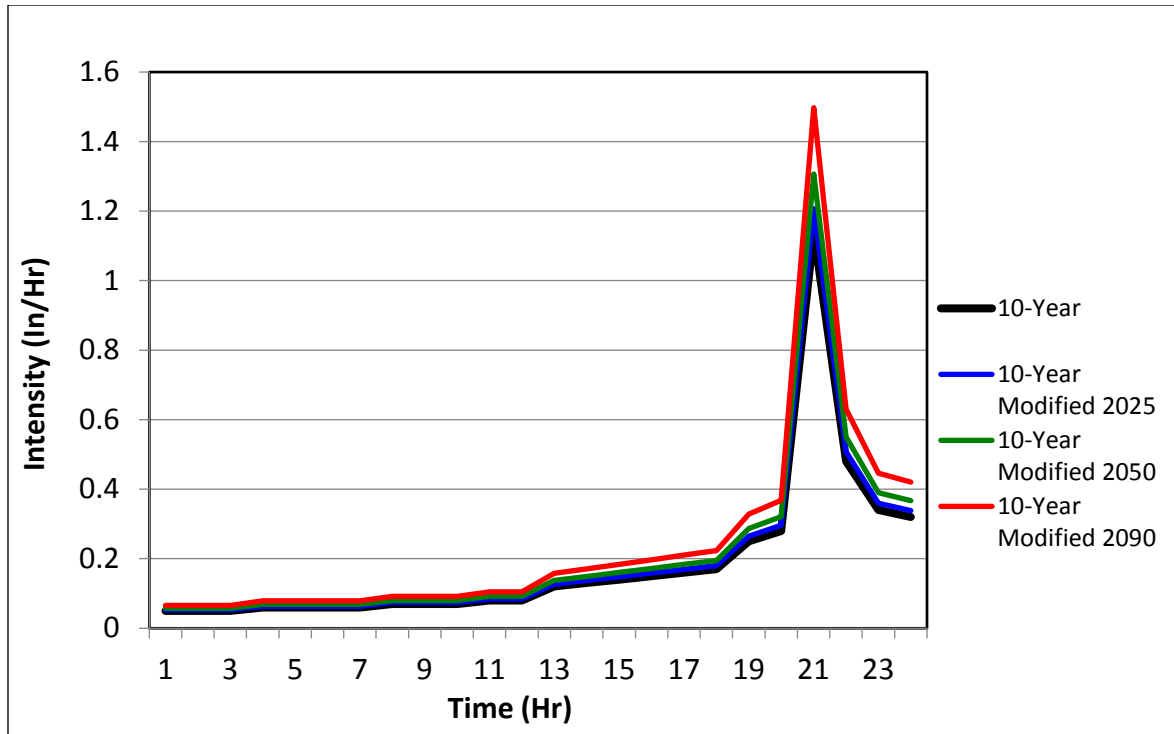

Figure 10.2 Current and Modified 10-Yr/24-Hr Design Storm Hyetograph

10.3.3 Hydraulic Modeling Analysis

MU hydraulic modeling analysis was conducted to analyze the impact of the modified design storm on the wastewater collection system. Due to findings from climate change vulnerability studies, three wet weather hydraulic modeling scenarios were analyzed to ascertain the impact of the modified design storm. The scenarios represent current and future rainfall conditions with existing and future base flow conditions in the system. Hydraulic capacity was evaluated by calculating surcharge conditions. It should be noted that the hydraulic model of the collection system does not represent all sewers in the system but provides reliable approximations of the hydraulic conditions within the collection system. The findings of modeling the three scenarios are discussed as follows.

Current Design Storm Analysis for Existing Flow Conditions

The hydraulic modeling of the current 10-year/24-hour design storm and existing base flows calculates that the overflowing maintenance holes mostly occur in the upstream portion of the collection system; this is due to their smaller pipe size and limited accuracy in reaches located upstream. Hydraulic modeling projected 49 maintenance holes with the potential to overflow which indicates WLAIS and its tributary branches in the west side of the system are more stressed than the WRS. The maintenance holes may not actually overflow during these conditions but indicate a location that should be monitored during extreme rainfalls.

Current Design Storm Analysis for Future Flow Conditions in Year 2050

The collection system modeled for future base flows in the year 2050 with the current design storm indicates that more base flow in the system will use more capacity in the system. Hydraulic modeling projected 65 maintenance holes with the potential to overflow Figure 10.3 with surcharging extended further upstream in the same areas as the existing condition scenario.

Modified Design Storm Analysis for Future Flow Conditions in Year 2050

The modified design storm was modeled with the future base flows for the year 2050 in this scenario. Hydraulic modeling projected 76 maintenance holes with the potential to overflow Figure 10.3 extending downstream. This indicates even more surcharging may occur in WLAIS and its tributary branches in the west side of the system in the future with more rainfall and increased flows.

10.3.4 Observations and Recommendations

The ten year design storm analysis was intended to evaluate the level of overflow protection available in the wastewater collection system under future rainfall and base flow conditions. Modeling indicates that increasing base flows in the system will reduce available capacity for wet weather flows. Applying the higher peak intensities of the climate change modified design storm resulted in calculating more surcharging than the current design storm. The difference in peak intensities was about 0.2 inch per hour and 0.77 inch per day. The locations of calculated surcharging of maintenance holes is color coded by the circles on Figure 10.3 for current rainfall and base flow conditions compared to the modified design storm with year 2050 base flows.

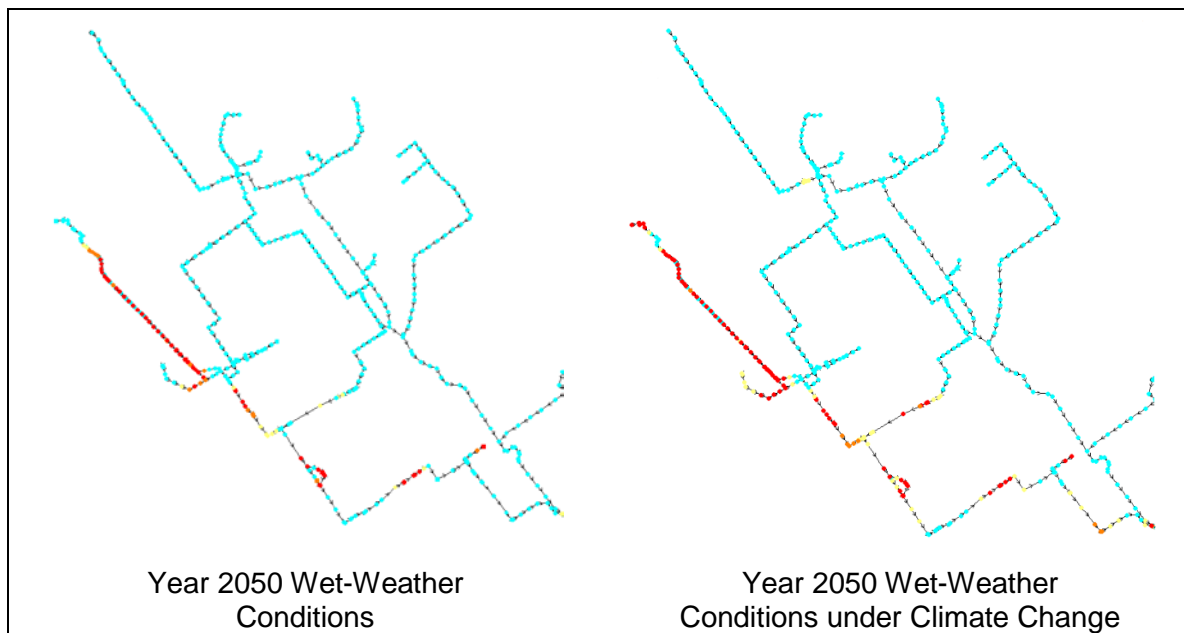

Figure 10.3 Calculated Collection System Surcharging for Design Storm with Existing Conditions and Climate Change Conditions in Year 2050

Additional surcharging locations are observed predominantly in the upstream portions of the collection system with smaller pipe sizes than the outfall/trunk sewers due to the way the model distributes flow. The collection system on the ground typically receives most of the RDII flow from the smaller diameter (less than 16 inches) secondary sewer pipes that offer attenuation and hydrodynamic buffering before they are introduced into the primary conveyance system. The MU hydrodynamic model doesn't include secondary sewer pipes and thus does not model hydraulic conditions for sewer pipes smaller than 15 inches.

The MU projected overflows under a 10-year rain event and was addressed by removing the 13.2 inches of silt constraining hydraulic capacity in the WLAIIS, as well as placing the sewer on a regular cleaning schedule to remove any future debris buildup. Understanding the higher peak intensities of the modified design storm under climate change conditions and its potential for overflow, it is recommended to continuously monitor and assess rain gauge data and the collection system's response to actual rain events. This enables planners and operators to better understand the needs of the collection system under changing weather patterns and plan accordingly.

10.4 FLOOD HAZARD ASSESSMENT

Flood hazard reduction measures should be uniformly applied to designs in or nearby flood hazard zones and tsunami zones following all applicable building codes with additional considerations for changing conditions due to climate change. Federal Emergency Management Agency (FEMA) recommends that essential facilities be elevated or protected to the higher of: the code-mandated elevation, the community-mandated elevation, or the 500-year flood elevation (FEMA, 2013a). Because of the inherent difficulties in predicting the exact elevation of flood waters due to variables such as weather, new land developments, blockages in the floodway, and other potential factors, a freeboard elevation should be taken into consideration for flood protection on top of the flood zone elevations. Freeboard is defined by FEMA as an additional amount of height above the base flood elevation (BFE) used as a factor of safety (e.g., 2 feet above the base flood) in determining the level at which a building's lowest floor must be elevated or flood-proofed to be in accordance with state or community floodplain management regulations (FEMA, 2013b). Hazard Mitigation Assistance and other Federal or State grants for elevating or reconstructing buildings often require projects to use BFEs or other freeboard requirements. The BFE is the elevation of flooding, including wave height, having a 1 percent chance of being equaled or exceeded in any given year – the 100-year storm.

Revisions made to the California Building Code in 2016 became effective on January 1, 2017. The 2016 California Building Code is based on the 2015 International Building Code (IBC). The IBC requires buildings to be designed and constructed in accordance with American Society of Civil Engineers (ASCE) 24. ASCE 24-14 requires between 0 and 2 feet of freeboard above a BFE (BFE + freeboard) or using a Design Flood Elevation (DFE), whichever is higher. The determination of the freeboard depends on the flood hazard zone, the importance of the building and how it may be categorized using an

ASCE classification system (ASCE, 2014). Flood Design Class 2 buildings and structures "pose a moderate risk to the public or moderate disruption to the community should they be damaged or fail due to flooding," which could be applied to stormwater pump stations, LFDs and stormwater treatment facilities. Class 3 includes "buildings and structures associated with power generating stations, water and sewage treatment plants, telecommunication facilities, and other utilities which, if their operations were interrupted by a flood, would cause significant disruption in day-to-day life or significant economic losses in a community." Class 4 includes buildings or structures that store or use hazardous fuels and hazardous chemicals. Water reclamation plants may be classified as per ASCE 24-14 as a Class 3 but more conservatively as a Class 4 building or structure.

The ASCE-recommended DFE in Standard 24-14 is calculated using the BFE plus a freeboard of 1 foot for inland areas or 2 feet for coastal zones for Class 3 buildings and structures. The DFE is the BFE plus a freeboard of 2 feet for inland and coastal zones or the 500-foot flood elevation, whichever is higher, for Class 4 buildings and structures.

Designs for facilities and operations with lifecycles extending through mid-century or the year 2100 should apply the FEMA and ASCE 24-14 requirements with an additional consideration for climate change. These considerations should include larger flood zones and higher flood elevations for inland waterways due to more intense precipitation in the future. Coastal design flood elevations should consider SLR. Facility designs in or adjacent to coastal flood hazard zones through mid-century should add 1.64 feet (0.5 meter) of SLR to the DFE. Long-term designs should add 4.92 feet (1.5 meters) of SLR to the DFE. These recommendations can be summarized as follows for lifecycles through mid-century and through year 2100:

- Mid-century: $DFE = BFE + \text{Freeboard} + 1.64 \text{ feet (0.5 meter)}$
- Year 2100: $DFE = BFE + \text{Freeboard} + 4.92 \text{ feet (1.5 meters)}$

The DFE should be applied to all structural, mechanical, electrical, and other components of facility designs for locating or relocating buildings and structures themselves or individual assets of a facility. The BFE should be first verified with the latest FEMA FIRMs and other flood management resources such as that provided by the USACE. The SLR component should be updated regularly by checking trends reported by NOAA and future projections by the Intergovernmental Panel on Climate Change (IPCC), National Climate Assessment, and regional efforts.

Submersible pumps are typically specified in any situation where a pump room may be flooded by either inundation during an event or by a failure of piping within the confined space of a facility where no drainage is possible. Electrical cabinets, motor control centers, variable frequency drives, instrumentation and controls, uninterruptable power sources, electrical supply, switch gear, backup power generation, on-site document storage, other water-sensitive equipment, and air vents should be located above the DFE. If not possible,

then redundant floodproofing should be applied to exteriors and interiors of structures depending on their criticality.

10.5 POWER SUPPLY AND BACKUP POWER GENERATION

All four water reclamation plants have two power feeds for electrical supply to provide redundancy in emergency conditions. However, power failures may still occur across multiple power grids and regions that will cause failures and backup power generation is needed to maintain operations and prevent environmental impacts. Pumping plants, LFDs and stormwater treatment systems typically have a single power feed. Permanent onsite or temporary portable backup power generation exists at these facilities across the City and instrumentation and controls are typically supplied with uninterruptable power sources for limited times. Power supply failures may increase in frequency and duration with increasing flooding risks and hotter days stressing power grids. Reliance on backup power will likely increase in the future.

Facility designs should include an initial energy audit to identify power requirements and energy saving opportunities via operations and equipment modifications and specification. Designs should use energy efficiency considerations to lower power requirements and in the case of a failure, extend the runtimes of permanent and/or portable backup power supplies with limited fuel reserves. The planning decision of designing for onsite permanent vs. temporary portable generators should still be made based on criticality of the facility, space, safety and other considerations presently taken. Where backup power is provided by portable generators, designs should feature "quick connect" capability (waterproof cabinets and connections in flood hazard zones), and the designated location of the portable generator.

10.6 FIRE AND LANDSLIDE ASSESSMENT

Pumping plants and other facilities are located in wildfire, landslide, and liquefaction zones. As the threat from fire increases in the future with higher temperatures and droughts, more proactive fire protection and prevention measures added to the design of facilities and the grounds around them will reduce that risk. Landslide potential will also increase with more extreme rainfalls (i.e. El Niño periods) alone and even more so in liquefaction zones and fire burn areas. Facility planning and design should first check the location of the facility against wildfire, landslide, and liquefaction zones to identify the risks and apply relative building codes.

Designs in wildfire zones should include fire protection for assets themselves and clearing vegetation and debris away from facilities in wildfire zones in cooperation with firefighting, parks, and forestry agencies to reduce the threat and consequences of wildfires. Slope stability at facilities in landslide and liquefaction zones should be verified and proactive design of erosion control and soil stabilization at facilities will reduce the risk of mudslide

and other impacts associated with increased average rainfall and intense rain events. Landscaping designs should include new vegetation that is preventing erosion and/or replace existing vegetation with drought-tolerant and/or fire-resistant vegetation.

10.7 SALT WATER INTRUSION ASSESSMENT

Saltwater intrusion of influent flows particularly effects facilities nearby the ocean. HWRP currently experiences salt water intrusion and is assessed for increasing vulnerabilities.

10.8 WATER RECLAMATION PLANT ASSESSMENTS

The City owns and operates four major water reclamation facilities: HWRP in Playa del Rey, the DCTWRP in the Sepulveda Basin, LAGWRP across the freeway from Griffith Park, and TIWRP in the vicinity of the Los Angeles Harbor. Each of these facilities was screened and assessed for existing and potential future climate hazards and the associated risks. This section summarizes the current and/or future risks, damage replacement costs associated with the risks, resilience improvement recommendations, and costs.

10.8.1 HWRP

The HWRP is located along the Pacific coast and adjacent to several flood hazard zones. Climate change conditions of increasing temperatures, SLR, and changes in rainfall may affect power supply, coastal flooding, tsunami and landslide hazards, as well as treatment processes. Increased temperatures and extreme events may cause more frequent power interruptions at the HWRP. Increased rainfall during extreme events may increase the risk of landslides or mudslides on the eastern slope of the facility. SLR may increase the impacts of coastal storm surges and tsunamis on the coastal zone and Vista del Mar roadway that is protecting the facility from flooding. SLR may also affect the impacts on tsunami wave action on the facility's outfalls. Assessments were performed on the flooding, power failure and erosion risks with climate change considerations to identify resilience improvements that address these risks.

10.8.1.1 Flood Hazard Assessment

The HWRP is not currently in but is adjacent to Pacific Ocean flood hazard zones. The FEMA BFE for the 100-year flood is 13 feet to 15 feet NAVD88 at the HWRP – two adjacent zones meet at the location of the HWRP. The 500-year BFE is not calculated by FEMA but is estimated to be 16.25 to 18.75 feet NAVD88. The HWRP is also adjacent to but not in a tsunami zone that may have wave heights of 20 feet. Vista Del Mar, the coastal road between the HWRP and the Pacific Ocean, is at elevations ranging from 39 feet to 47 feet NAVD88. This elevation provides protection against these current coastal flooding hazards. Estimated SLR of 1.5 to 5.0 feet will likely not raise the BFEs or potential tsunami waves above the elevation of Vista Del Mar. Erosion of the beach and roadway may ensue with SLR and reduced beach sand replenishment (Grifman et al, 2013), and if future coastal

storms increase in frequency and intensity. Vista Del Mar is in an earthquake liquefaction zone that may not have the structural integrity to withstand a concurrent tsunami during or following a seismic event. Further study of its integrity is recommended in cooperation with Los Angeles County.

The overall total replacement value of the HWRP has been estimated to be \$3 billion (Grifman et al, 2013). Impacts to individual pieces of equipment would cost significantly less than the loss of the entire facility for a given catastrophic event. Grade elevations at the facility are approximately 30 feet or higher compared to sea levels and therefore above-grade assets are not likely at risk to flooding due to coastal storms and tsunamis now and with SLR should a breach of Vista del Mar occur. However, the HWRP is served by subgrade galleries that house pumps, power feeds, controls, etc. Access to the galleries is raised above grade to prevent stormwater from entering. Sump pumps in the galleries pump out groundwater seepage via the stormwater system to the 1-mile ocean outfall but are not designed for a gallery flooding event. Should a flooding event occur, the galleries may be flooded and significant damage would be sustained by the facility that would cause a process shutdown and necessitate significant repairs costing millions of dollars.

Effluent pumping assures discharge during higher tidal and coastal storm conditions. This will likely require more power usage in the future at higher sea levels and during more frequent coastal storms. The 1- and 5-mile ocean outfalls may also be susceptible to worse hydraulic forces in the future during a coastal storm or tsunami with SLR and should be investigated further.

10.8.1.2 Backup Power Generation Assessment

HWRP's power demand is usually met by the onsite power generated at Hyperion Bio-Energy Facility by consuming digester gas. Some natural gas is supplemented to meet Hyperion's demand. As needed, excess power from the Hyperion Bio-Energy Facility can be exported to LADWP, and power can be imported from LADWP to meet Hyperion's demand. HWRP is connected to LADWP's power grid by two independent feeders.

During a power outage from LADWP, the Hyperion Bio-Energy Facility can function separated from the LADWP's grid and supply power to Hyperion. The Hyperion Bio-Energy Facility is equipped with its own black-start generator. Separate from the Bio-Energy Facility, Hyperion has two Power Restart generators, which can be positioned to supply power to any processes, but with limited capacity. Moreover, some of critical processes or facilities have dedicated generators. These dedicated generators are Headworks, Intermediate Pumping Plant, Service Water Facility, and Technical Support Facility. Project development is underway with LADWP to provide full backup power to the facility to eliminate this risk.

10.8.1.3 Erosion and Landslide/Mudslide Assessment

The high eastern slope at the HWRP is a landslide hazard zone that may erode during extreme wet weather or seismic events. An existing retaining wall along the foot of slope protects most assets during a landslide event. There is approximately 1,100 feet without wall and some assets may be damaged and facility roadways may be blocked should a slide occur. A damage cost due to a landslide could total \$5,000,000.

Enhancing slope stabilization methods and lengthening existing retaining walls along the foot of the eastern slope are recommended to stabilize slopes and protect assets during a landslide event in the short term with an estimated construction cost of \$600,000.

10.8.1.4 Saltwater Intrusion Assessment

Saltwater intrusion of influent flows at the HWRP is a growing concern with rising influent TDS concentrations that may worsen with SLR and could impact future effluent water reuse; it should be monitored and evaluated for the cost-effectiveness of future source reduction efforts vs. enhanced treatment.

10.8.1.5 Findings and Recommended Resilience Improvements

The overall current and future climate hazards risk assessment for the HWRP is low.

Capital and non-capital facility planning recommendations for the HWRP for climate change considerations are as follows:

- Enhance slope stabilization and lengthen existing retaining wall approximately 1,100 feet to complete wall along eastern edge of facility - \$600,000 conceptual construction cost.
- Perform a structural analysis of Vista Del Mar with Los Angeles County to determine structural stability of roadway during future flood and seismic/tsunami conditions.
- Evaluate tsunami impacts to HWRP hydraulics including tsunami magnitude needed to damage outfalls or hydraulically block effluent discharge.
- Monitor influent TDS and consider performing a cost benefit analysis of lining pipes versus treatment to mitigate higher influent TDS concentrations for water reuse purposes.

10.8.2 DCTWRP

The DCTWRP is located in the Sepulveda Flood Control Basin administered by USACE. Climate change conditions of increasing temperatures and changes in rainfall may affect power supply and flooding hazards, causing more frequent power interruptions at the DCTWRP. Assessments were performed to understand the flooding and power failure risks associated with climate change considerations to identify resilience improvements that address these risks.

10.8.2.1 Flood Hazard Assessment

The DCTWRP is located in the Sepulveda Flood Control Basin administered by the USACE. The facility is between Haskell Canyon Creek to the east, Woodley Creek to the west and the Los Angeles River to the south that each contains a 100-year flood within their banks according to the FEMA FIRMs. The DCTWRP is currently in a mapped flood zone but outside a 500-year flood hazard zone with no calculated BFE on the FEMA FIRMs. Earthen berms on the south and east sides, and a floodwall on the west side protect the facility from flooding for a 100-year flooding event with a BFE of 712.0 feet NGVD29 (714.6 feet NAVD88) plus freeboard. The 200- and 500-year flood elevations calculated by the USACE are 713.5 feet NGVD29 (716.1 feet NAVD88) and 714.6 feet NGVD29 (717.2 feet NAVD88), respectively.

The USACE informed LASAN in 2014 that it requires the flood protection be raised to a Standard Project Flood elevation of 713.5 feet NGVD29 (716.1 feet NAVD88) plus 2.7 feet of freeboard. The DFE would be 716.2 feet NGVD29 (718.8 feet NAVD88). Raising protective berms and improving structures and gates to this DFE will be required for an estimated construction cost of \$4,500,000. The implementation of the improvements is a short-term priority as per the USACE agreements.

LASAN estimated in December 2015 that the cost of flooding the DCTWRP is \$52,345,275. This estimate is for value of the equipment generally below elevation 716.72 feet NGVD29 (719.32 feet NAVD88), which is the elevation of the primary settling tank walls (Arcadis, 2016).

Changing rainfalls may increase the frequency and severity of high river flows and flooding in the Sepulveda Flood Control Basin. The improvements required by the USACE will protect the DCTWRP for a current 200-year flood protection level plus freeboard. The additional 2.7 feet of freeboard, a DFE of 716.2 feet NGVD29 (718.8 feet NAVD88), protects the DCTWRP for the current 500-year event with 1.6 feet of freeboard. This 1.6 feet of freeboard provides extra protection for the facility should climate change increase extreme rainfalls and river flows in the future. No additional flood protection improvements for climate change considerations are warranted at this time.

10.8.2.2 Backup Power Generation Assessment

Power is supplied to the DCTWRP via two power feeds. Backup power is provided only for the headworks with 12 hours of onsite fuel. Full operations are not possible should a power failure occur. Individual uninterruptible power supplies are distributed throughout the facility for instrumentation and controls. In case of an emergency, the DCTWRP can bypass to the HWRP. Process recovery for full secondary treatment however would take approximately two weeks or longer if all processes were shut down and biomass is lost.

CIP #6145, Backup Power, will provide emergency backup power for the critical load so DCTWRP will not violate its NPDES permit in case the existing power feeders are lost. This

ongoing project will also remove the existing emergency backup generator and underground tank. Backup generators are scheduled to be installed as a medium priority in the next 10 years for a cost of \$7,712,900.

10.8.2.3 Findings and Recommended Resilience Improvements

The overall current and future climate hazards risk assessment for the DCTWRP is low with implementation of the flood protection and power improvements that are already planned as follows:

- Add backup power generation for the critical load - \$7,712,900
- Raise protective berms and add structures and gates - \$4,500,000

No additional capital or non-capital resilience improvements are recommended for the DCTWRP for climate change considerations.

10.8.3 LAGWRP

LAGWRP is located along the Los Angeles River in a flood hazard zone. Climate change conditions of increasing temperatures and changes in rainfall may affect power supply and flooding hazards. This may change the recurrence interval, extent, and impact of flooding events. For instance, river flows and associated flood hazards for the 100-year event (1 percent chance of annual occurrence) may have the characteristics of the 500-year event (0.2 percent chance of annual occurrence) in the future. Increased temperatures and extreme events may cause more frequent power interruptions at the LAGWRP.

Assessments were performed on the flooding and power failure risks with climate change considerations to identify future projects that address these risks.

10.8.3.1 Flood Hazard Assessment

An engineered riverbank along the Los Angeles River protects the LAGWRP from high river stages. The LAGWRP is currently in a flood zone but outside a 500-year flood hazard zone with no calculated BFE. The outfall to the Los Angeles River through the engineered riverbank does not have gates to prevent backflow from the river into the outfall at elevated river stages. The dechlorination effluent weir is at a high elevation such that processes are protected from backflow from the Los Angeles River. However, there is an open grate on the outfall between dechlorination and the engineered riverbank such that the river will flood the facility at river stages higher than the grate elevation but lower than the top of the riverbank. Installing gates on the outfall with an estimated construction cost of \$400,000 will prevent river backflow from flooding the LAGWRP in this scenario.

A recent floodplain analysis by the USACE shows the facility will be flooded during 100- and 500-year flood events by the Los Angeles River (USACE, 2016). Calculated inundation pathways are overland along the north side of the LAGWRP and over the levee along the west side of the LAGWRP. Four-foot high temporary barriers were positioned by the USACE along the levee in December 2015, but they are not intended as permanent protection and would not protect the facility during 100- and 500-year events. Entrances to below-grade pipe galleries, pump rooms, and control rooms are protected by submarine doors. However, the USACE calculations are for 3 to 5 feet of water above grade in the facility for the 100-year event and 5 to 10 feet of water above grade for the 500-year event. These depths may be higher in the future with climate change affecting future rainfalls and river flooding conditions. Should a flooding event occur, it would likely damage all structures and processes with damage costs to the facility on the order of \$75,000,000.

Subgrade structures may be protected by the existing submarine doors. However, the existing administration building, motor control centers (MCC) and pumps, instrumentation and controls and other electrical and mechanical systems above grade are vulnerable to being damaged by flooding. Elevating and/or waterproofing individual assets or constructing a flood barrier system around the LAGWRP would be required to protect the facility from Los Angeles River flooding. Constructing floodwalls with flood-proof gates and other structural enhancements integrated with the existing engineered riverbank to protect the entire facility would be required for a likely construction cost of \$10,000,000.

10.8.3.2 Backup Power Generation Assessment

Power is supplied to the LAGWRP via two power feeds. A backup generator powers the influent pumping plant and one aeration blower only. Individual uninterruptible power supplies are distributed throughout the facility for instrumentation and controls. Full operations are not possible should a power failure occur. In case of an emergency, the LAGWRP can bypass to the HWRP. Biomass can be maintained with one blower for the aeration system in operation at low level but not for an extended period. Process recovery for full secondary treatment, however, would take approximately two weeks or longer if all processes were shut down and biomass is lost.

To power the LAGWRP for full operations, additional backup power generation would be required for the administration building, existing primary clarifiers, aeration tanks, final clarifiers, RAS pumps, filter pumps, tertiary filters, chlorination and dechlorination systems, and reclaimed water delivery systems. The likely construction cost of adding backup power for these systems would be \$4,000,000. This estimated conceptual-level cost is based on the \$7,712,900 cost for adding backup power generation to the DCTWRP for powering the minimal critical load to meet NPDES requirements, and scaling it down considering the smaller size of LAGWRP (20 mgd) compared to DCTWRP (80 mgd) and existing partial backup power generation at LAGWRP.

10.8.3.3 Findings and Recommended Resilience Improvements

The overall current and future climate hazards risk assessment for the LAGWRP is very high due to the flood hazard and backup power deficiency.

Capital and non-capital facility planning recommendations for the LAGWRP for climate change considerations are as follows:

- Add backup power generation for entire facility - \$4,000,000 construction cost.
- Install backflow prevention gates on outfall to Los Angeles River - \$400,000 construction cost.
- Construct floodwalls with flood-proof gates and other structural enhancements - \$10,000,000 construction cost.
- Evaluate condition of existing submarine doors and include maintenance and regular exercise of doors in the facilities Standard Operating Procedure (SOP).

10.8.4 TIWRP

The TIWRP is surrounded by flood hazard zones and is in a tsunami zone. Climate change conditions of increasing temperatures and SLR may affect power supply, coastal flooding, and tsunami hazards. Increased temperatures and extreme events may cause more frequent power interruptions at the TIWRP. Assessments were performed on the flooding and power failure risks with climate change considerations to identify resilience improvements that address these risks.

10.8.4.1 Flood Hazard Assessment

The TIWRP is currently in a flood zone, but outside a 500-year flood hazard zone with no calculated BFE. The 100-year BFE in harbor waters at the TIWRP is 9 feet NAVD88. The average ground elevation on the TIWRP property is 10 feet NAVD88, just above the BFE for the 100-year flood. A BFE for the 500-year flood is not provided on FEMA flood insurance rate maps (FIRMs). However, the 500-year BFE may be estimated as 11.25 feet NAVD88, which is higher than the TIWRP ground elevation. The TIWRP is in a tsunami zone that may have wave heights of 20 feet. SLR of 1.5 to 5.0 feet will raise the 100-year BFE to flood the facility in the medium to long term.

Below-grade pipe galleries, pump rooms, and control rooms are unprotected for flooding during an inundation event. Entrances to the galleries are typically at curb level to prevent stormwater ponding from entering stairways but there are no submarine or other watertight doors on the entrances or vent grates. The facility experienced a flooding incident in January 2017 in which a spill occurred (an estimated 1,000 gallons breached a sand bagged area and sewage mixed with storm runoff flowed onto Terminal Way). Two below-grade galleries were flooded and equipment was damaged (pump motors, actuators, and communication cabinets). The damage would have been avoided if critical equipment vulnerable to water damage were not located below-grade in galleries.

Administration buildings, MCCs and pumps, instrumentation and controls and other electrical and mechanical systems above grade throughout the facility are vulnerable to being damaged by flooding. A cost analysis was performed during the 2015-2016 EPA CREAT exercise to determine the anticipated replacement costs if TIWRP is inundated by a coastal flooding event. Systems critical to the operation of the facility will likely be damaged or destroyed by the flood waters and debris. An American Academy of Water Resources Engineers (AAWRE) Class 5 cost estimate was performed to identify the value of work to repair or replace the following electrical, instrumentation, control, and mechanical assets that would likely be affected by flood waters:

- Headworks building and lift station - \$11,000,000
- MCCs throughout the facility - \$15,800,000
- Advanced Water Purification Facility (AWPF) - \$15,000,000
- Effluent pumping plant including standby generators - \$11,000,000

The combined replace-in-kind cost estimate for the headworks building and lift station, MCCs throughout the facility, AWPF and the effluent pumping plant is \$52,800,000. This estimated cost does not represent the likely full value of replace-in-kind costs for the existing facility, which would likely exceed \$100,000,000. In addition, the TIWRP AWPF expansion is valued at over \$50,000,000, which will also be at risk in a flooding event. A likely damage cost for the entire facility could exceed \$150,000,000.

Elevating and/or waterproofing individual assets that are vulnerable to water damage would provide protection from coastal storm flooding, tsunamis, and/or internal flooding events such as the event that occurred in January 2017. Constructing a flood barrier system around the TIWRP would be required to protect the entire facility from coastal storm and tsunami flooding, but would not protect individual assets from internal flooding events. Constructing floodwalls using the existing perimeter walls as a base, adding flood-proof gates, and other structural enhancements to protect the entire facility would be required as a medium term priority for a likely construction cost of \$10,000,000.

10.8.4.2 Backup Power Generation Assessment

An electrical substation is located at the TIWRP and is fed with two separate feed lines with switchgear that facilitates a power feed from one line at a time. There are two large diesel backup generators for the facility that are located at the EPP and in the Filter Area. The EPP generators have a 1,500 kilowatts (kW) capacity with a 23-hour run time before needing refueling of its 9,800 gallon tank. The Filter Area generators have a 500 kW capacity with a 25-hour run time before needing refueling of its 400 gallon tank. These generators do not power the entire facility, but do power the following processes and mechanical equipment: 2# Filter Influent Pump, Filter Backwash Air Blower, Filter Backwash Pump, In-plant Lift Station Pump, Grit Collector, Bar Screen, Compressor, Filter Backwash Air Blower and Pump, Aeration Tank Blower, EPP Pump, Return Activated Sludge Pump and the Filter Influent Pump. Individual uninterruptible power supplies are distributed throughout the facility for instrumentation and controls.

Backup generators are included in the Phase II of the AWPf (BOE CIP #5244, LASAN CIP #1583) but only to power the AWPf at an estimated cost of \$10,000,000. Additional backup power generators will be needed for the entire facility in the case of a power failure at a likely cost of \$4,000,000. This estimated conceptual-level cost is based on the \$7,712,900 cost for adding backup power generation to the DCTWRP for powering the minimal critical load to meet NPDES requirements, and scaling it down considering the smaller size of TIWRP (30 mgd) compared to DCTWRP (80 mgd) and existing partial backup power generation at TIWRP.

10.8.4.3 Findings and Recommended Resilience Improvements

The overall current and future climate hazards risk assessment for the TIWRP is high due to the flood hazard and backup power deficiency.

Capital facility planning recommendations with conceptual construction costs for the TIWRP for climate change considerations are as follows:

- Add backup power generation to power the entire facility - \$4,000,000
- Construct flood walls and add structures and gates - \$3,730,000

10.9 SUMMARY OF RECOMMENDED PROJECTS

Facility improvement prioritization is based on the hazard conditions at each location. After selecting asset locations, climate scenarios, threats, and assets of concern, LASAN and CH2M assessed the risks and consequences of climate-related threats considering existing resources and projects previously planned. Resilience improvement recommendations described in Section 10.3 and 10.8 were prioritized for short-, medium-, or long-term implementation depending on the level and timing of risks as shown in Table 10.4. The schedule time periods listed in Table 10.4 are assumed to include the initiation of facility planning activities that would move to design and construction.

| Table 10.4 Climate Change Risk Analysis Prioritization Wastewater Facilities Plan One Water LA 2040 Plan | | |
|-------------------------------------------------------------------------------------------------------------------------|-----------------|--------------------------------------------------------------------------------------------------------|
| Priority | Schedule | Criteria |
| Short term | 1 to 5 years | 100-year flood, or fire hazard, or landslide zone |
| Medium term | 5 to 10 years | 100-year flood zone with 0.5 meter of sea level rise |
| Long term | 10 to 25 years | 500-year flood zone, or 100-year flood zone with 1.5 meters of sea level rise, or current tsunami zone |

The following describes the prioritization and scheduling of pumping plant, LFD, and water reclamation plant recommendations.

10.9.1 Pumping Plants and LFD Improvements Prioritization

Table 10.5 lists the wastewater and stormwater pumping plants and LFDs at risk to current or future threats, type of pumping plant, their prioritization for short-, medium- or long-term improvements, the estimated damage replacement costs, and the estimated resilience improvement capital costs. Table 10.5 is sorted by priority according to the criteria shown in Table 10.4.

Estimated resilience improvement capital costs total \$1,620,000 for short-term, \$1,600,000 for medium-term, and \$13,586,000 for long-term implementation, in current dollars. The estimated resilience improvement cost for wastewater pumping plants is \$12,966,000, for stormwater pumping plants is \$1,860,000, for LFDs is \$380,000, and \$1,570,000 for LFD/stormwater facilities (647 Kinney Circle and LA Zoo). The overall estimated resilience improvement cost for pumping plants and LFDs is \$16,806,000.

Figure 10.4 shows the locations of the water reclamation plants and at-risk wastewater, stormwater pumping plants and LFDs.

| Table 10.5 Pumping Plants Identified for Climate Hazard Improvements Wastewater Facilities Plan One Water LA 2040 Plan | | | | | |
|---------------------------------------------------------------------------------------------------------------------------------------|----------------------|-------------|-----------------|----------------------------------------------------|------------------------------------------------------|
| Plant No. | Name | Type | Priority | Estimated Damage Replacement Cost (\$1,000) | Resilience Improvement Capital Cost (\$1,000) |
| 611 | Riverdale | WW | Short Term | \$21.6 | \$50 |
| 614 | Tuxford (LFD) | LFD | Short Term | \$650 | \$90 |
| 624 | Roscomare | WW | Short Term | \$1,000 | \$20 |
| 628 | Corbin | WW | Short Term | \$1,000 | \$0 |
| 634 | Temescal | WW | Short Term | \$3,159 | \$60 |
| 638 | Palisades | WW | Short Term | \$1,000 | \$0 |
| 639 | North Pulga | WW | Short Term | \$2,106 | \$60 |
| 668 | Henry Ford | WW | Short Term | \$4,744 | \$230 |
| 734 | Temescal | LFD | Short Term | \$650 | \$60 |
| 740 | Westside Park | LFD | Short Term | \$650 | \$90 |
| ZOO | LA Zoo | LFD/SW | Short Term | \$8,424 | \$960 |
| 666 | Fries Ave | WW | Medium Term | \$5,195 | \$1,110 |
| 686 | Nissan Way | WW | Medium Term | \$1,193 | \$490 |
| 687 | North Neptune | WW | Long Term | \$1,000 | \$400 |
| 646 | Venice Pumping Plant | WW | Long Term | \$31,590 | \$1,600 |
| 647 | Kinney Circle | SW/LFD | Long Term | \$3,750 | \$610 |
| 648 | Thompson | WW | Long Term | \$1,000 | \$480 |
| 649 | Jefferson | WW | Long Term | \$1,000 | \$80 |
| 669 | Harris Place | WW | Long Term | \$1,123 | \$810 |
| 671 | Terminal Way | WW | Long Term | \$7,020 | \$1,070 |
| 672 | Murdock & I | WW | Long Term | \$1,000 | \$720 |
| 676 | Mcfarland | WW | Long Term | \$5,616 | \$1,020 |
| 677 | Hawaiian & "B" | WW | Long Term | \$4,072 | \$870 |
| 680 | 22nd & Signal | WW | Long Term | \$1,000 | \$126 |
| 681 | Ports 'O' Call | WW | Long Term | \$1,000 | \$340 |
| 683 | 22nd Street | WW | Long Term | \$1,000 | \$500 |
| 684 | Miner | WW | Long Term | \$1,000 | \$500 |
| 685 | Signal | WW | Long Term | \$1,000 | \$480 |
| 689 | Seaside | WW | Long Term | \$1,000 | \$600 |
| 690 | Anchorage | WW | Long Term | \$1,000 | \$300 |
| 691 | San Pedro | WW | Long Term | \$12,636 | \$1,080 |
| 692 | Southerland | SW | Long Term | \$23,166 | \$1,860 |
| 733 | Santa Monica | LFD | Long Term | \$1,300 | \$140 |
| Total Cost | | | | \$131,066 | \$16,806 |
| Abbreviations: | | | | | |
| WW = wastewater, SW = stormwater, LFD = low flow diversion | | | | | |

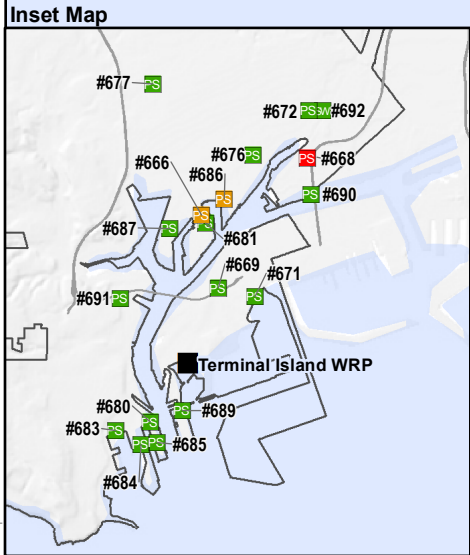
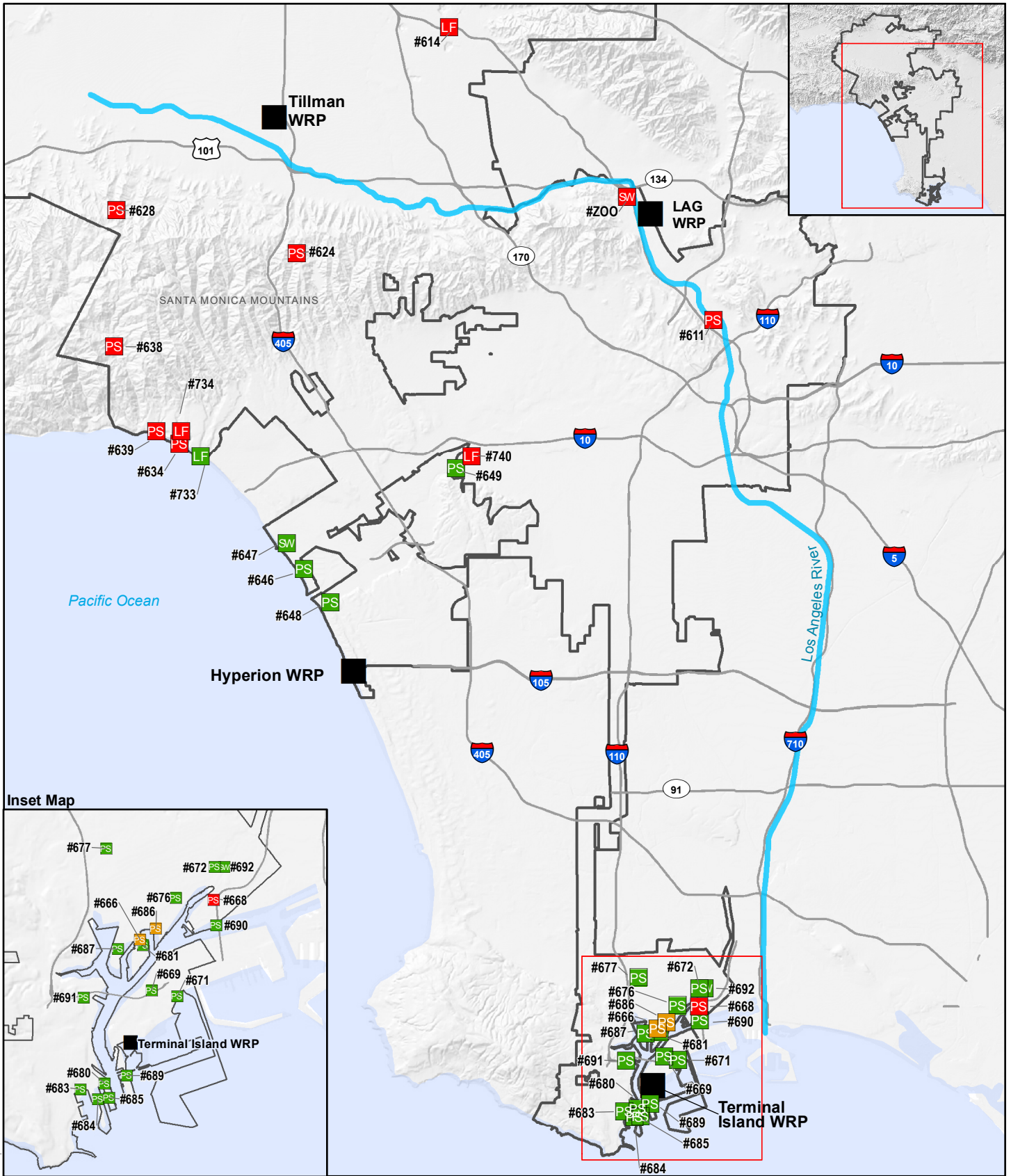

Legend

- Existing Water Reclamation Plant (WRP)
- City of Los Angeles

Resilience Work Priority by Plant

- Low Flow Diversion Plant
- Long Term Priority
- Short Term Priority
- Wastewater Pumping Plant
- Long Term Priority
- Medium Term Priority
- Short Term Priority

Stormwater Pumping Plant

- Long Term Priority
- Short Term Priority



0 1 2 Miles

Hillshade Source: CalAtlas
<http://www.atlas.ca.gov>

Figure 10.4
Wastewater and Stormwater Pumping Plants and Low Flow Diversions with Current and/or Future Climate Hazard Risks
 One Water LA 2040 Plan

Document Path: C:\Users\jsilber\Desktop\OWLA\MXD\TM5.5\AirRiskPSLFD.mxd

10.9.2 Water Reclamation Plant Improvements Prioritization

The overall climate-hazard risk assessment and recommendations for the four water reclamation plants were described in Section 10.8. Some of the recommendations are for capital improvements and operational changes that could be implemented following the prioritization schedule shown in Table 10.4. While other recommendations are for investigative or other activities that would be implemented prior to facility planning. Operational recommendations may be implemented immediately. These recommendations should be assessed prior to implementation for future considerations. The following are recommendations on the implementation of those recommendations for each of the water reclamation plants, prioritized based on the individual threat/risk pairs and associated timing.

HWRP has an overall current and future climate hazards risk assessment of low. The ongoing project to provide full backup power to the facility is recommended to continue in the short term. Given the recent extreme rainfalls experienced in the Los Angeles area in 2017 and potential worsening future El Niño conditions, enhancing slope stabilization and lengthening the existing retaining wall along the eastern edge of facility is recommended in the short term for the estimated \$600,000 conceptual construction cost. Monitoring influent TDS and performing a cost benefit analysis of lining pipes versus treatment to mitigate higher influent TDS concentrations for water reuse purposes is also recommended for the short term in order to plan ahead for future sewer improvement of WRP process improvements. Evaluating tsunami impacts to HWRP hydraulics and performing a structural analysis of Vista Del Mar with Los Angeles County are recommended for medium-term implementation.

DCTWRP has an overall current and future climate hazards risk assessment of low with the immediate implementation of the flood protection and power improvements that are already planned as follows. Adding backup power generation and raising the protective berms for a combined estimated cost of \$12,212,900 is recommended to be prioritized and implemented in the short term.

LAGWRP has an overall current and future climate hazards risk assessment of very high due to the Los Angeles River flood hazard and backup power deficiency. Therefore, all resilience improvements are recommended to be implemented in the short term. The condition of the existing submarine doors should be evaluated and new operation and maintenance procedures should be implemented immediately to protect the galleries from flooding. Project planning and design for improving flood protection for a combined estimated capital cost of \$10,400,000 for raising the flood protection elevation and adding backflow prevention gates on the outfall is recommended to be implemented in the short term. Adding backup power generation for entire facility for \$4,000,000 in estimated construction cost is also recommended for the short term.

TIWRP has an overall current and future climate hazards risk assessment of high due to the flood hazard and backup power deficiency. The TIWRP is not in a current flood hazard zone but SLR may put it in the flood hazard zone by mid-century. The TIWRP is in a tsunami zone. Therefore, the flood protection improvement recommendation of constructing flood walls is recommended for medium-term prioritization (\$10,000,000 estimated construction cost) following the prioritization schedule in Table 10.4. However, a January 2017 spill event at the TIWRP resulted in the flooding of two below-grade galleries and damaging assets. Therefore, relocating and/or waterproofing equipment in below-grade galleries is recommended for any TIWRP improvement project in the short-term. Backup power generation should be added for the entire facility in the short term for an estimated construction cost of \$4,000,000.

In summary, short term recommended resilience improvements for the water reclamation plants total \$31,212,900 in estimated construction costs. The medium-term estimated construction cost in today's dollars is \$10,000,000. There are no long-term resilience recommendations for water reclamation plants.

10.9.3 Other Considerations

It is also recommended that, as part of the design review, climate trends and changes that are immediate to the City be considered. The trends should be reviewed for the following parameters/threats that affect planning and design:

- Rainfall volumes and peak intensities
- Number of hot days
- Tsunami and flood hazard zones with sea level rise
- Population
- Wildfire, landslides, liquefaction
- Drainage and roadway design
- Stormwater and sanitary sewer design

As projects start design, it is recommended that the following attributes be reviewed:

- Service life exceeded
- Failures
- Changes in function (capacity, service area change)
- Criteria for climate risk and resilience
- Likelihood of failure based on hazards/risk

- Consequence of failure associated with hazards/risk
- Cost
- Loss of service for Public Health and Safety
- Environmental Impacts

WASTEWATER FACILITIES ADAPTIVE CAPITAL IMPROVEMENT PLAN

A comprehensive wastewater facilities Capital Improvement Plan (CIP) has been developed that includes projects and cost estimates for each of the four water reclamation plants (WRPs) and the collection system. CIP information specific to each of these facilities is also provided in the corresponding chapter dedicated to that facility. The purpose of this chapter is to compile the identified capital improvement projects for the WRPs and collection system, and provide a comprehensive CIP that can be used as a guide for long-term financial and resource planning. The sources used to develop the CIP include the Los Angeles Bureau of Engineering (LABOE) Uniform Project Reporting System (UPRS), LASAN Wastewater Capital Improvement Plan (WCIP), LADWP 2015 UWMP, and concept options developed as part of the One Water LA 2040 Plan.

Projects are categorized as:

- **In-Progress Projects:** water supply projects implemented outside of this Plan
- **Current Integration Opportunities:** satellite treatment facilities under consideration
- **Future Integration Opportunities:** concept options developed as part of this Plan
- **Estimated and Projected CIP:** projects identified or projected using current CIP information

The projects within these categories are further delineated in terms of:

- Facilities location – by water reclamation plant or the collection system
- Project type/category – Replacement & Rehabilitation (R&R), Capital, Climate Resiliency
- Implementation phase – Near-term, Mid-term, and Long-term

This chapter presents the basis used for estimating project related costs as well as the terms and definitions used in the CIP. Subsequently, the four project categories above are individually presented followed by Wastewater Facilities Plan Adaptive CIP.

11.1 BASIS FOR ESTIMATE OF COST

An initial step in the projection of future expenditures is the compilation of cost information for identified projects. All costs included in this compilation are in 2017 dollars. Within the City, cost estimates for specific projects are typically developed using a bottom-up methodology separately calculating labor and material cost. Overhead and profit are applied based on City-allowable overhead and profit.

After development, cost estimates for projects are documented in three different sources:

- WCIP – The WCIP includes capital developed for the City's Clean Water facilities. The projects included in this document have been approved by the City's Program Review Committee, comprised of Assistant Directors of LASAN and a Deputy City Engineer. The administration, coordination, and implementation of the projects in the 10-Year (FY 2015/16-2024/25) WCIP are assigned to various divisions of LASAN and BOE in the Department of Public Works. The Program includes replacement, rehabilitation, and expansion of the City's wastewater treatment and collection system facilities.
- Los Angeles Bureau of Engineering UPRS – The UPRS is the publicly available source for projects documented in the WCIP and other sources. The UPRS was used in conjunction with the WCIP to cross reference projects for inclusion in the Wastewater Facilities Plan Adaptive CIP.
- Los Angeles Department of Water and Power UWMP – Every five years LADWP develops a new UWMP that documents the City's efforts since the previous document, updates goals for the next 25 years, and identifies changes since the previous document.

Two principal cost components of future estimated CIP expenditures are:

- Future Integration Opportunities costs
- Estimated and Projected CIP costs

Future integration opportunities (concept options) were developed as part of the One Water 2040 Plan. The capital costs for the concept options were estimated using planned treatment components of the WRPs and estimated unit costs. These unit costs are based on industry standards and include construction contingencies. Land acquisition costs are not included and all costs have a 2.0 multiplier as these projects are preliminary in nature. The cost estimating methodology, including details of the 2.0 multiplier and unit cost estimates, used for the concept options is described further in Volume 5.

Projected annual costs include both capital and replacement and rehabilitation related projects. The primary source of cost information was the existing WCIP. Costs reported in the WCIP were exported directly into the Wastewater Facilities Plan Adaptive CIP. In those instances where no data was available from the WCIP or the estimate was a low value, an analysis was undertaken to develop representative annual costs. Separate methodologies were used for capital projects and replacement and rehabilitation costs. These are discussed below:

- **Capital Projects:** Where no data was available or the estimate was a low value, annual CIP costs for capital projects at each WRP were developed using the most recent, available CIP (FY 2015/16 – 2024/25). Only the first seven years of expenditures of this CIP were used, as the last three years showed a sharp decline

(order of magnitude) and judged non-representative. Seven years of annual WRP projected costs were averaged to calculate a projected future annual average rate of expenditure. The projected annual cost was estimated to be \$136 million as shown on Figure 11.1.

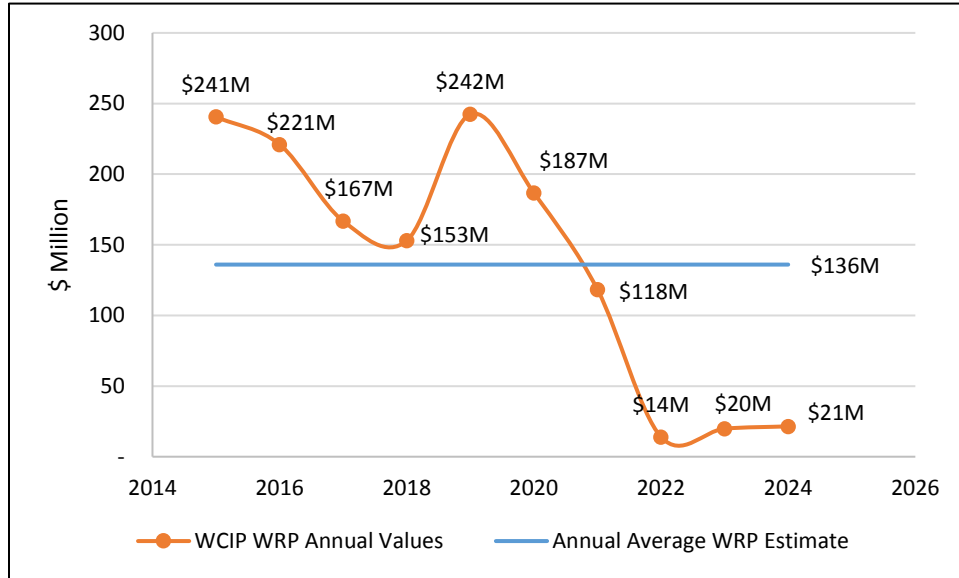

Figure 11.1 Projected Annual Estimate of Cost for WRP

The total annual WRP average was further divided between WRPs using the respective plant’s percentage of the total over the same seven year period. Each of the expenditures by WRP was then adjusted to remove the replacement and rehabilitation costs which were separately calculated. The result was a series of projected annual costs for each WRP for capital projects. These are listed below.

- Projected annual capital cost for DCTWRP is \$25 million per year
- Projected annual capital cost for LAGWRP is \$6 million per year
- Projected annual capital cost for TIWRP is \$14 million per year
- Projected annual capital cost for HWRP is \$92 million per year
- **Replacement and Rehabilitation:** Where no replacement and rehabilitation cost were available or the estimate was a low value, annual costs were estimated based on a percentage of the asset value of the WRP. The asset value was calculated based on a dollar per million gallon per day of capacity basis. For WRPs with less than 100 mgd of capacity, the replacement and rehabilitation costs were estimated to be 1 percent of the total asset value. For WRPs with greater than 100 mgd of capacity, the replacement and rehabilitation costs were estimated to be 0.5 percent of the asset value. This is due to an economy of scale that is recognized as well as the large capital value that resides in the tannage. The dollar per mgd value used for

HWRP and TIWRP was estimated to be a greater than the value used for DCTWRP and LAGWRP due to the inclusion of solids handling process. Future climate resiliency costs were assumed to be part of the replacement and rehabilitation estimates. The following values were used in estimating replacement and rehabilitation annual cost for each WRP:

- Asset value for DCTWRP is \$12/mgd and 1 percent of the calculated asset value;
- Asset value LAGWRP is \$12/mgd and 1 percent of the calculated asset value;
- Asset value for TIWRP is \$16/mgd and 1 percent of the calculated asset value; and
- Asset value for HWRP is \$16/mgd and 0.5 percent of the calculated asset value.

The projected costs for capital and replacement and rehabilitation projects using these methodologies are summarized in Table 11.1.

| Table 11.1 Projected Capital and Replacement and Rehabilitation Estimates Wastewater Facilities Plan One Water LA 2040 Plan | | | | |
|--------------------------------------------------------------------------------------------------------------------------------------------|--------------------------|----------------------------|----------------------------|---------------------------|
| Category | HWRP (\$M/yr) | DCTWRP (\$M/yr) | LAGWRP (\$M/yr) | TIWRP (\$M/yr) |
| Projected Capital Estimate | \$92 | \$25 | \$6 | \$14 |
| Projected R&R Estimate | \$36 | \$10 | \$2 | \$5 |
| Total | \$128 | \$35 | \$8 | \$19 |
| Notes: | | | | |
| (1) The values are estimated for inclusion in the Wastewater Facilities Adaptive CIP. | | | | |

These annual values are translated to phase equivalent in the following sections.

11.2 CIP TERMS AND DEFINITIONS

The CIP compiles the projects identified from the sources outlined above and provides a summary based on the category and phase for each facility, WRPs, and collection system. The terms and definitions used are summarized in Table 11.2.

| Table 11.2 CIP Terms and Definition Wastewater Facilities Plan One Water LA 2040 Plan | | |
|------------------------------------------------------------------------------------------------------------------------------------------------------------------------------------------------------------------------------------|--------------------------------------------|------------------------------------------------------------------------------------------------------------------------------------------------------------------------------------------------------------------------------------------------------------------------------------------------------------------------------------------------------------------------|
| Group | Term | Definition |
| Category | Capital Project from WCIP | These projects were previously identified in the WCIP. These projects include new construction, expansion, or renovation that helps maintain or improve a City facility or infrastructure that may be funded by the Capital Budget. |
| | R&R from WCIP | These are projects identified in the WCIP. These projects are needed for the continued operation of the facility in its present form. |
| | Climate Resiliency Projects ⁽¹⁾ | These are projects developed as part of the Plan and identified in Volume 6 Climate Risk and Resilience Assessment for Wastewater and Stormwater Infrastructure. These projects are needed to adapt to environmental conditions due to climate change. |
| | Projected Capital Projects | These are projects not identified in the WCIP and are projected as part of the WWFP in collaboration from City staff. These projects include new construction, expansion, or renovation that helps maintain or improve a City facility or infrastructure that may be funded by the Capital Budget. Project costs were estimated using the methodology in Section 11.1. |
| | Projected R&R Projects | These are projects not identified in the WCIP and are projected as part of the WWFP in collaboration with City staff. These projects may be needed for the continued operation of the facility in its present form. Project cost were estimated using the methodology in Section 11.1. |
| Phase ⁽²⁾ | Near-Term | Projects that are planned to be constructed between 2018 to 2020 |
| | Mid-Term | Projects that are planned to be constructed between 2021 and 2030 |
| | Long-Term | Projects that are planned to be constructed between 2031 and 2040 |
| <p>Note:</p> <p>(1) Climate resiliency projects were identified based on the analysis described in Volume 6.</p> <p>(2) The phases were determined by LASAN and LADWP management for all projects included in the Plan.</p> | | |

The following sections use the sources, methodologies, terms and definitions to present the In-Progress Projects, current integration opportunities, future integration opportunities and the WWFP Adaptive CIP Summary.

11.3 IN-PROGRESS PROJECTS

In-Progress projects are defined as planned supply projects or programs for groundwater, recycled water, and stormwater that are expected to be implemented outside and independent of the Plan. Table 11.3 summarizes the In-Progress Projects relevant for this WWFP, along with their respective estimated capital costs, projected construction completion, and resulting phase. Additional details of these In-Progress Projects can be found in Volume 5.

| Table 11.3 Summary of In Progress Project Estimated Costs Wastewater Facilities Plan One Water LA 2040 Plan | | | |
|------------------------------------------------------------------------------------------------------------------------------------------------------------------------------------------------------------------------------------------------------------------------------|------------------------------------------------------------------|--------------------------|--------------|
| In-Progress Projects | Estimated Capital Cost Estimate (\$2017) Millions | Year Complete | Phase |
| Advanced Treated Recycled Water Delivery to LAX and Scattergood Generating Station | \$38 ⁽¹⁾ | 2019-2020 | Near |
| HWRP Delivery Expansion to 70 mgd for WBMWD and LA Harbor Area | \$16 ⁽²⁾ | 2020 | Near |
| DCTWRP Groundwater Replenishment Project with AWPf | \$370 ⁽³⁾ | 2023 | Near/Mid |
| LAGWRP Increase Recycled Water Demand per 2015 UWMP | \$73 | 2018-2020 | Near |
| TIWRP AWPf Expansion to 12 mgd (Completed in 2017) | \$n/a ⁽⁴⁾ | Mid-2017 | Near |
| Total | \$497 | | |
| Note: | | | |
| (1) Cost of phase 1 of this project is estimated at \$38 million, scheduled to occur in the near-term. Expansion of additional 3.5 mgd (product water) could occur in the mid-term, for an estimated capital cost of \$92 million for a total capital cost of \$130 million. | | | |
| (2) The estimated capital cost is for the expansion of the pump station and does not include WBMWD's costs. An additional cost of \$400 million could be incurred in the future should 70 mgd of MBR treatment be installed at HWRP. | | | |
| (3) Groundwater Replenishment Project with AWPf identified by a WCIP. Phasing will be split into near term and mid-term. | | | |
| (4) TIWRP Expansion to 12 mgd was completed during the finalization of the WWFP. For this reason, it has not been included in the total cost of the In-Progress Projects. | | | |

The City is demonstrating a commitment to focus significant resources on alternative water supply sources through the implementation of In-Progress projects such as the

Groundwater Replenishment Project with AWPf at DCTWRP and the Advanced Treated Recycled Water Delivery to LAX and Scattergood Generating Station.

11.4 CURRENT INTEGRATION OPPORTUNITIES

New water reclamation plants are being considered to provide satellite treatment in communities with limited access to reclaimed water and a proven cost effective demand for its use. New water reclamation plants were evaluated as a current integration opportunity. Of the 45 current integration opportunities identified, one opportunity is applicable to the WWFP, namely the Rancho Park WRF. The Rancho Park WRF would be a one or multiple satellite water reclamation facilities in the Rancho Park area, which would provide a stormwater capture and treatment system along with a satellite WRP to meet non-potable demands in the regional service area. This conceptual cost estimate was developed based on other similar projects, industry publications and pipeline installation costs. The project provides the following benefits:

- Produces recycled water to meet substantial non-potable demands in the Westside area, including industrial uses and irrigation for the UCLA campus, the City’s largest municipal golf course, and several other users.
- Captures stormwater to retain, treat, and remove pollutants such as trash, metals, and bacteria
- Increases reliability of supply by being locally sourced and climate resilient

The estimated conceptual cost in 2017 dollars for this project is \$58 million.

11.5 FUTURE INTEGRATION OPPORTUNITES

Individual future integration opportunities are called ‘concept options’. Concept options were developed as part of the One Water LA 2040 Plan to increase the local supply availability and achieve water quality targets. These future integration opportunities were reviewed and ranked to establish the “preferred portfolio”. The preferred portfolio is a list of recommended concept options that may be implemented in the future, based on the results of a portfolio analysis and discussions with City staff. The Priority A - Preferred Portfolio includes the following concept options:

- Concept Option #5- Dry Weather Low Flow Diversions
- Concept Option #8B - LA River Recharge to the LA Forebay using Dry Wells
- Concept Option #13 – Potable Reuse from MBR at HWRP to Regional System
- Concept Option #15 – Potable Reuse with Raw Water Augmentation DCTWRP to LA Aqueduct Filtration Plant (with #22 East-West Valley Interceptor Sewer)

- Concept Option #17 – Potable Reuse with Treated Water Augmentation LAGWRP to Headworks Reservoir
- Concept options #22 – East-West Valley Interceptor Sewer (required for Concept Option #15)

The concept options that make up the Preferred Portfolio will be implemented based on "triggers." Triggers are defined as an "internal or external force (an event or situation) that causes to happen or exist." Triggers determine if a concept option will be implemented or not. If not, subsequent projects may be considered. Known triggers are described in Chapter 10 of the Plan’s Summary Report (see Volume 1).

11.5.1 Trigger Based CIP Implementation

The recommended Preferred Portfolio consists of the most preferred concept options and is identified as "Priority A." The next most preferred concept options are identified as "Priority B" and then "Priority C." By applying the appropriate triggers to the proposed concept options identified in the Preferred Portfolio, LASAN, LADWP and/or their future project partners would be able to identify and implement a project as needed. Note, at each decision point all triggers should be revisited and concept option priorities should be updated to account for any changed future conditions. The following section describes the preferred concept options for each WRP.

11.5.1.1 HWRP

Seven concept options involving some form of water reuse from the HWRP were identified and evaluated, as listed in Table 11.4. Figure 11.2 presents a trigger-based implementation strategy for HWRP future integration opportunities.

| Table 11.4 HWRP Concept Options Wastewater Facilities Plan One Water LA 2040 Plan | | | | | |
|--------------------------------------------------------------------------------------------------|--------------------------------------------------|----------------------------------------------------|--------------------------------------|-----------------------------------------|--------------------------|
| Concept Option # | Title | Strategy | Estimated Yield (Normal Year) | Capital Cost (\$M)⁽¹⁾ | Unit Cost (\$/AF) |
| 10 | Hyperion WRP to West Coast Basin Injection Wells | Potable Reuse with Groundwater Augmentation | 20,000 AFY (17 mgd) | \$900 | \$3,200 |
| 11 | Hyperion WRP to Central Basin Injection Wells | Potable Reuse with Groundwater Augmentation | 75,000 AFY (70 mgd) | \$3,300 | \$2,700 |
| 13 | MBR at Hyperion WRP to Regional System | Potable Reuse with Groundwater Augmentation | 95,000 AFY (85 mgd) | \$900 | \$1,500 |

| Table 11.4 HWRP Concept Options Wastewater Facilities Plan One Water LA 2040 Plan | | | | | |
|----------------------------------------------------------------------------------------------------------------------------------------------------------------------------------------------------------------------|-------------------------------------------------------|-----------------------------------------------|--------------------------------------|-----------------------------------------|--------------------------|
| Concept Option # | Title | Strategy | Estimated Yield (Normal Year) | Capital Cost (\$M)⁽¹⁾ | Unit Cost (\$/AF) |
| 14 | Hyperion WRP to San Fernando Basin Injection Wells | Potable Reuse with Groundwater Augmentation | 20,000 AFY (18 mgd) | \$680 | \$2,400 |
| 18 | Hyperion WRP to LADWP Distribution System | Potable Reuse with Groundwater Augmentation | 95,000 AFY (85 mgd) | \$2,800 | \$2,100 |
| 19 | Hyperion WRP to Headworks Reservoir | Potable Reuse with Treated Water Augmentation | 95,000 AFY (85 mgd) | \$3,200 | \$2,400 |
| 20 | Hyperion WRP to Los Angeles Aqueduct Filtration Plant | Potable Reuse with Raw Water Augmentation | 95,000 AFY (85 mgd) | \$3,600 | \$2,600 |
| Note: | | | | | |
| (1) Total Concept Option cost includes a variety of project components including treatment facilities, conveyance, and injection and extraction facilities. Not all costs pertain to the Wastewater Facilities Plan. | | | | | |
| (2) Bold indicates a Priority A Concept Option | | | | | |
| (3) Concept Option #12 was determined to have a fatal flaw resulting from 1) a lack of capacity in the existing Rio Hondo Spreading Grounds and 2) a lack of vacant land to construct new spreading basins. | | | | | |

The most critical trigger to implement the Priority A Concept Option #13 (MBR at HWRP to Regional System) is establishing an institutional agreement with a regional project partner, such as Metropolitan Water District (MWD), the Water Replenishment District (WRD), LACSD, and/or WBMWD. If such an agreement does not materialize, the Priority B and C options could also be considered.

The most critical trigger for the Priority B Concept Option #18 (HWRP to LADWP Distribution System) is adopting potable reuse with treated water augmentation regulations that would allow this type of water reuse practice. If the potable regulations are not accepted within a desired timeframe, or if the City prefers a more conventional form of water reuse, the third-best potable reuse options from HWRP are Concept Options #10 and #11. These options consist of groundwater augmentation in the West Coast and Central Basin, respectively. Both options require an institutional agreement with WRD, who acts as the Watermaster for these two groundwater basins. In case such an agreement does not materialize and potable reuse regulation are not approved, it is recommended to postpone the implementation of a large scale potable reuse project from HWRP, which is indicated as "No Change" on Figure 11.2.

The key benefits associated with Concept Option #13 (MBR at HWRP to Regional System) include:

- Maximizing HWRP's flows for reuse reducing discharge to the ocean.
- Promotes collaboration with regional partners
- Delivers water to a regional system for reuse such as recharge into a groundwater basin that may be extracted for potable reuse and sold to water retailers at full service rates.

Moreover, this concept option helps fulfill the following One Water key objectives and guiding principles:

- Implement, monitor, and maintain a reliable wastewater system.
- Improve local water supplies reliability.
- Integrate management of water resources & policies.
- Increase climate resilience.

Hyperion Water Reclamation Plant

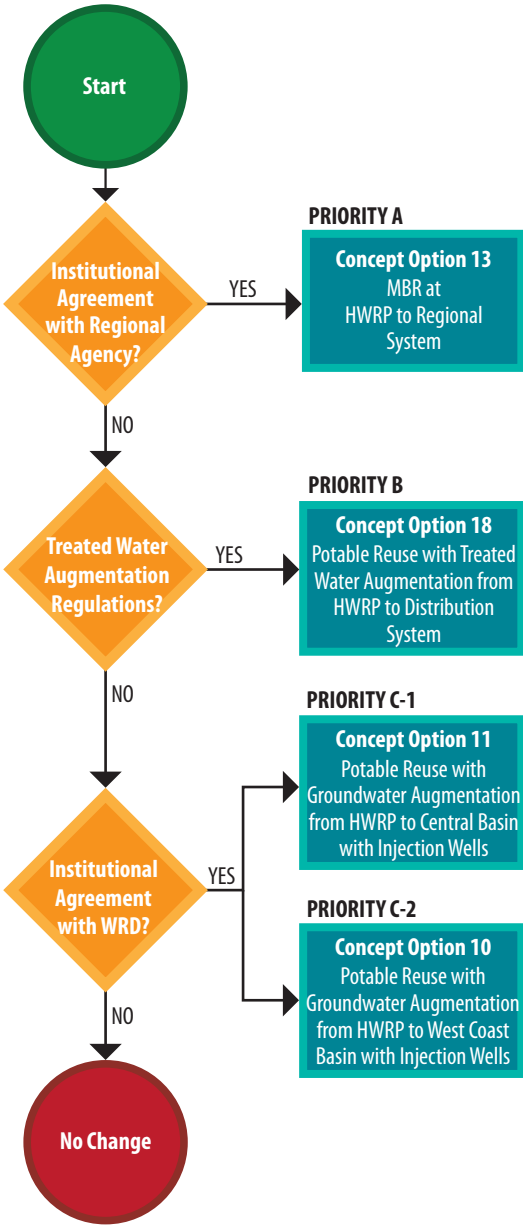

LEGEND & ACRONYMS

- ◆ Trigger
- Concept Option
- Flow Management Option

| | |
|--------|-----------------------------------------------------|
| DCTWRP | Donald C. Tillman Water Reclamation Plant |
| GWR | Groundwater Replenishment Project |
| HWRP | Hyperion Water Reclamation Plant |
| LAGWRP | LA-Glendale Water Reclamation Plant |
| RWQCB | Regional Water Quality Control Board |
| TIWRP | Terminal Island Water Reclamation Plant |
| WRD | Water Replenishment District of Southern California |

Disclaimer: At each trigger (decision point), evaluate all triggers and concept option priorities to consider changed circumstances in the future.

Figure 11.2
Trigger-Based Implementation Strategy for HWRP
One Water LA 2040 Plan
Summary Report

11.5.1.1 DCTWRP

Six concept options that involve potable water reuse from DCTWRP were identified and evaluated. These concept options, shown in Table 11.5. Figure 11.3 presents a trigger-based implementation strategy for DCTWRP future integration opportunities.

| Table 11.5 DCTWRP Concept Options Summary Report One Water LA 2040 Plan | | | | | |
|----------------------------------------------------------------------------------------------------------------------------------------------------------------------------------------------------------------------|-------------------------------------------------------------|--------------------------------------------------|--------------------------------------|-----------------------------------------|--------------------------|
| Concept Option # | Title | Strategy | Estimated Yield (Normal Year) | Capital Cost (\$M)⁽¹⁾ | Unit Cost (\$/AF) |
| 7 | Upper Los Angeles River to Tillman WRP | LA River Storage and Use | 5,600 AFY (5 mgd) | \$18 | \$160 |
| 9 | Tillman WRP to San Fernando Basin Injection Wells | Potable Reuse with Groundwater Augmentation | 15,000 AFY (14 mgd) | \$360 | \$1,600 |
| 15 | Tillman WRP to Los Angeles Aqueduct Filtration Plant | Potable Reuse with Raw Water Augmentation | 15,000 AFY (14 mgd) | \$310 | \$1,500 |
| 16 | Tillman WRP to LADWP Distribution System | Potable Reuse with Treated Water Augmentation | 15,000 AFY (14 mgd) | \$295 | \$1,300 |
| 22 | East-West Valley Interceptor Sewer | Flow Management | 12,800 AFY (11.41 mgd) | \$85 | \$430 |
| 26 | Japanese Garden & Sepulveda Basin Lakes Recirculation | Flow Management | 20,000 AFY (18 mgd) | \$20 | \$70 |
| Note: | | | | | |
| (1) Total Concept Option cost includes a variety of project components including treatment facilities, conveyance, and injection and extraction facilities. Not all costs pertain to the Wastewater Facilities Plan. | | | | | |
| (2) Bold indicates a Priority A Concept Option | | | | | |

The most critical trigger of any of the Priority A, B, or C options is the ability to increase recycled water flow availability to DCTWRP. Due to the success of water conservation and the ongoing groundwater replenishment project, all existing flows have been accounted for. Hence, the first trigger is a decision to pursue and implement a flow management project to divert additional wastewater flows to DCTWRP. Once the City makes this decision, the next

trigger is the approval of a wastewater change petition from the Division of Water Rights per Water Code Section 1211 to allow a reduction in effluent discharge from DCTWRP to the LA River.

If this petition is approved, the City could proceed with Concept Option #26. By implementing some type of flow recirculation project for the Japanese Garden and Sepulveda Basin Lakes, a portion of the DCTWRP effluent that is currently discharged into the LA River could be repurposed for potable reuse.

If this petition is not approved, the City would need to proceed with Concept Option #22 and increase flow availability to DCTWRP by constructing the EWVIS project, which consist of a 6-mile sewer forcemain and six lift stations to bring wastewater flows from the eastern part of the San Fernando Valley to DCTWRP.

The next most critical triggers are related to the adoption of potable reuse regulations. The highest ranked potable reuse opportunity (Concept Option #15 - DCTWRP to LAAFP) would require acceptance of potable reuse with raw water augmentation, while the second highest concept option (#16 - DCTWRP to Distribution System) would require acceptance of potable reuse with treated water augmentation. In case the potable regulations are not accepted within a desired timeframe or if the City prefers a more conventional form of water reuse, the third best potable reuse option from DCTWRP is Concept Option #9 (Groundwater Augmentation from DCTWRP to San Fernando Basin Injection Wells). If none of the flow management strategies are feasible nor the potable reuse regulations are approved, it is recommended to postpone any new water recycling projects from DCTWRP. This decision is indicated as "No Change" on Figure 11.3.

11.5.1.2 LAGWRP

Two concept options were identified and evaluated for the LAGWRP as part of the future strategies previously described. These concept options are shown in Table 11.6.

The most critical trigger, as shown on Figure 11.4 for the implementation of this concept option is adopting potable reuse regulations with treated water augmentation that would allow this type of water reuse practice. If the potable regulations are not accepted within a desired timeframe, or if the City prefers a more conventional form of water reuse, the Priority B Concept Option #23 (NPR expansion beyond 2015 UWMP) could be considered for the remaining available flows. The most critical trigger for this concept option is new customer demand that is cost-effective to serve considering the customer location, demand size, demand variability, and water quality requirements.

| Table 11.6 LAGWRP Concept Options Wastewater Facilities Plan One Water LA 2040 Plan | | | | | |
|----------------------------------------------------------------------------------------------------|-------------------------------------------------|------------------------------------------------------|--------------------------------------|-----------------------------------------|--------------------------|
| Concept Option # | Title | Strategy | Estimated Yield (Normal Year) | Capital Cost (\$M)⁽¹⁾ | Unit Cost (\$/AF) |
| 17 | LAGWRP to Headworks Reservoir | Potable Reuse with Treated Water Augmentation | 6,000 AFY (5 mgd) | \$140 | \$1,500 |
| 23 | Increase Recycled Water Demand beyond 2015 UWMP | Non-Potable Reuse | 3,500 AFY (3 mgd) | \$70 | \$2,100 |

Note:
 (1) Total Concept Option cost includes a variety of project components including treatment facilities, conveyance, and injection and extraction facilities. Not all costs pertain to the WWFP.
 (2) This capital cost reflects the proportion of costs specifically for LAGWRP to implement Concept Option #23 (Increase Recycled Water Demand beyond 2015 UWMP). The cost was calculated using proportions of yield and cost relative to overall concept implementation cost.
 (3) Bold indicates a Priority A Concept Option

The key benefits associated with this concept option consist of:

- Expands LAGWRP’s treatment technology and increases flows available for water reuse
- Expands use of potable reuse with treated water augmentation

Moreover, this concept option helps fulfill the following One Water key objectives and guiding principles:

- Implement, monitor, and maintain a reliable wastewater system
- Improve local water supplies reliability
- Integrate management of water resources and policies
- Increase climate resilience

11.5.1.3 TIWRP

Currently the majority of the plant flow is treated and reused. Additionally, future projected tributary flow increases are limited. Due to these considerations, the estimated available flow for additional water reuse is constrained. As a result, no concept options were identified for TIWRP.

Donald C. Tillman Water Reclamation Plant

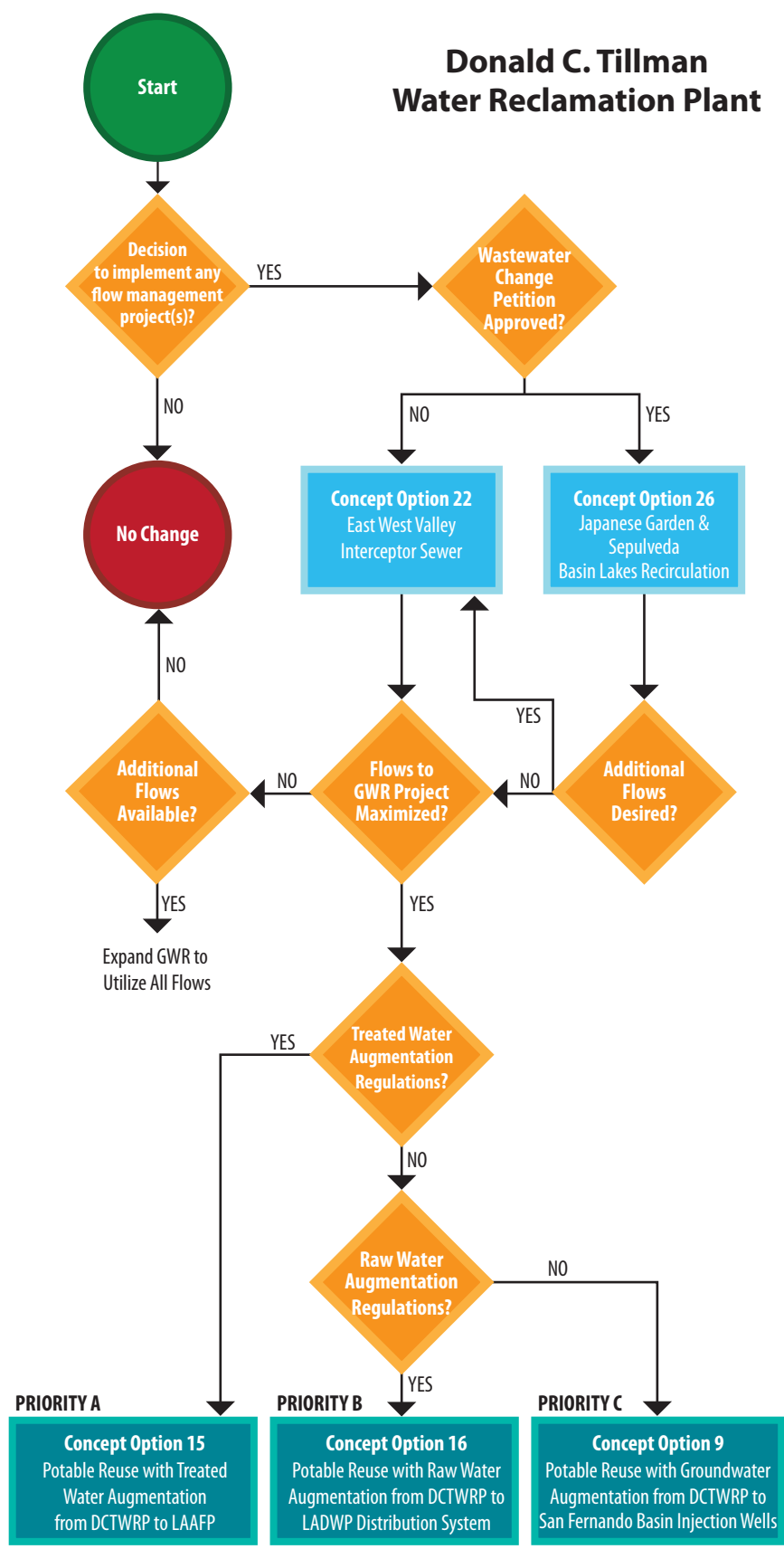

LEGEND & ACRONYMS

- ◆ Trigger
- Concept Option
- Flow Management Option

DCTWRP Donald C. Tillman Water Reclamation Plant
 GWR Groundwater Replenishment Project
 HWRP Hyperion Water Reclamation Plant
 LAGWRP LA-Glendale Water Reclamation Plant
 RWQCB Regional Water Quality Control Board
 TIWRP Terminal Island Water Reclamation Plant
 WRD Water Replenishment District of Southern California

Disclaimer: At each trigger (decision point), evaluate all triggers and concept option priorities to consider changed circumstances in the future.

Figure 11.3
Trigger-Based Implementation Strategy for DCTWRP
 One Water LA 2040 Plan
 Summary Report

LA-Glendale Water Reclamation Plant

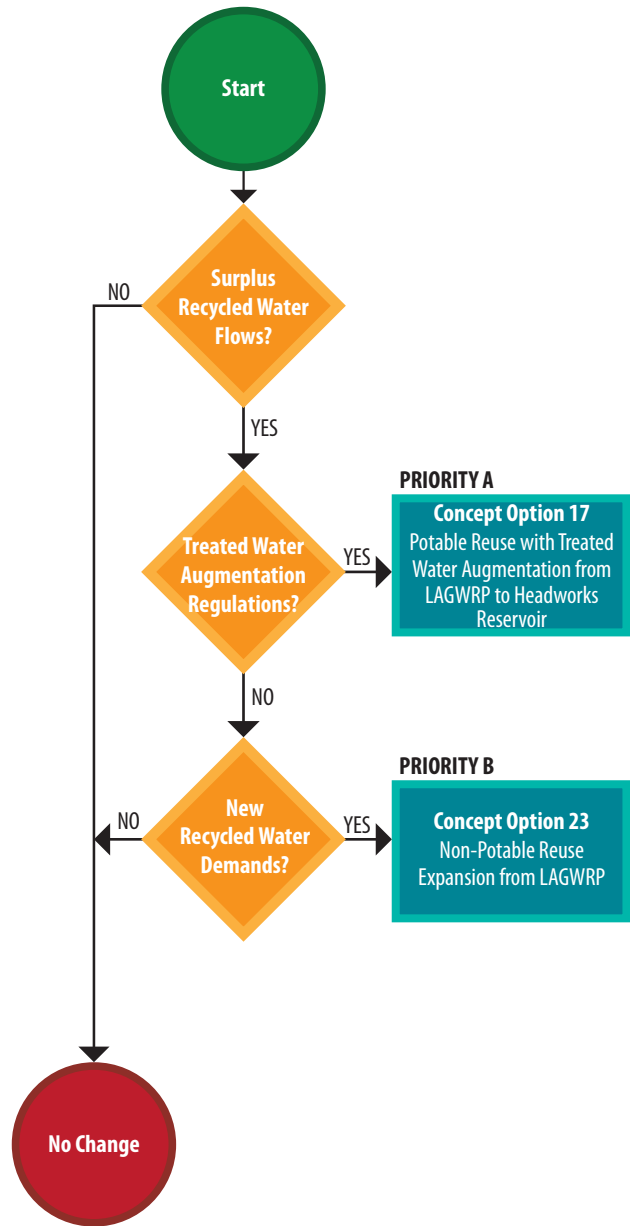

LEGEND & ACRONYMS

- ◆ Trigger
- Concept Option
- Flow Management Option

| | |
|--------|-----------------------------------------------------|
| DCTWRP | Donald C. Tillman Water Reclamation Plant |
| GWR | Groundwater Replenishment Project |
| HWRP | Hyperion Water Reclamation Plant |
| LAGWRP | LA-Glendale Water Reclamation Plant |
| RWQCB | Regional Water Quality Control Board |
| TIWRP | Terminal Island Water Reclamation Plant |
| WRD | Water Replenishment District of Southern California |

Disclaimer: At each trigger (decision point), evaluate all triggers and concept option priorities to consider changed circumstances in the future.

Figure 11.4
Trigger-Based Implementation Strategy for LAGWRP
One Water LA 2040 Plan
Summary Report

11.5.2 Concept Option Summary

Table 11.7 contains a summary of the priority concept options for each of the water reclamation plants. The total cost for the concept option is presented as well as the WWFP portion of the costs. Capital costs from each of the concept options are sourced from the technical memoranda where this information was developed (see Volume 5).

| Table 11.7 Summary of Concept Option Portfolios Wastewater Facilities Plan One Water LA 2040 Plan | | | | | |
|------------------------------------------------------------------------------------------------------------------|-----------------|----------|-------------------------------------------------|-------------------------------------------------------------------|-----------------------------------|
| WRP | Priority | # | Concept Option Name | Total Future Integration Opportunities Cost Estimate (\$M) | WWFP Portion of Cost (\$M) |
| HWRP | A | 13 | MBR at HWRP to Regional System | \$900 | \$900 |
| | B | 18 | Hyperion to LADWP Distribution System | \$2,800 | \$2,500 |
| | C-1 | 11 | HWRP to Central Basin Injection Wells | \$3,300 | \$1,700 |
| | C-2 | 10 | HWRP to West Coast Basin Injection Wells | \$900 | \$450 |
| DCTWRP | A | 15 | DCTWRP to LA Aqueduct Filtration Plant | \$310 | \$220 |
| | A | 22 | East-West Valley Interceptor Sewer | \$85 | \$85 |
| | B | 16 | DCTWRP to LADWP Distribution System | \$295 | \$260 |
| | C | 9 | DCTWRP to San Fernando Basin Injection Wells | \$360 | \$200 |
| LAGWRP | A | 17 | LAGWRP to Headworks Reservoir | \$140 | \$120 |
| | B | 23 | Increase Recycled Water Demand beyond 2015 UWMP | \$70 | \$0 |

Concept options that are identified as Priority A are the recommended Preferred Portfolio. The WWFP portion of these concept options has been integrated into the WWFP Adaptive CIP. Table 11.8 summarizes the most critical trigger for Priority A concept options.

| Table 11.8 Summary of Priority A Triggers Wastewater Facilities Plan One Water LA 2040 Plan | | | |
|----------------------------------------------------------------------------------------------------------------|-------------------|----------------------------------------|------------------------------------------------------------------------------------------------------------------------------------------------------------------------------------------------------------------------------------------------------------------------------------------------------------------------------------------------------------------------------------------------------------------------------------------------------------------------------|
| WRP | # | Concept Option Name | Trigger |
| HWRP | 13 | MBR at HWRP to Regional System | The most critical trigger for this concept option is establishing an institutional agreement with a regional project partner, such as MWD, WRD, LACSD, or WBMWD. |
| DCTWRP | 22 | East-West Valley Interceptor Sewer | The most critical trigger is the ability to increase wastewater flow to DCTWRP, which will in turn increase the potential for recycled water. The first trigger is a decision to pursue and implement any flow management project. Once the city makes this decision, the next trigger is the approval of a wastewater change petition from the Division of Water Rights per Water Code Section 1211 to allow a reduction in effluent discharge from DCTWRP to the LA River. |
| DCTWRP | 15 ⁽¹⁾ | DCTWRP to LA Aqueduct Filtration Plant | The most critical trigger for the implementation of this concept option is adopting potable reuse with raw water augmentation regulations. |
| LAGWRP | 17 | LAGWRP to Headworks Reservoir | The most critical trigger for the implementation of this concept option is the approval of potable reuse regulations for treated water augmentation that would allow this type of water reuse. |
| <u>Note:</u> | | | |
| (1) Implementation of this concept option is dependent on a flow management option such as Concept Option #22. | | | |

11.6 WASTEWATER FACILITIES PLAN CIP SUMMARY

The WWFP CIP summary combines the projects previously discussed in this chapter. The CIP summary consolidates In-Progress Projects, capital projects, replacement and rehabilitation projects, climate resiliency projects, current integration opportunities and future integration opportunities, and organizes these projects by intended implementation phase.

Table 11.9 summarizes the number of projects in each category, organized by facility. These projects and their respective costs are further discussed in this section.

| Table 11.9 Number of Projects by Facility Wastewater Facilities Plan One Water LA 2040 Plan | | | | | | |
|------------------------------------------------------------------------------------------------------------|-----------------------------|-------------------------|----------------|---------------------------|-----------------------------------------|--------------|
| Facility | In-Progress Projects | Capital Projects | R&R | Climate Resiliency | Future Integration Opportunities | Total |
| HWRP | 2 | 7 | 37 | 1 | 1 | 48 |
| DCTWRP | 1 | 23 | 8 | 2 | 2 | 36 |
| LAGWRP | 1 | 2 | 18 | 3 | 1 | 25 |
| TIWRP | 1 | 10 | 18 | 2 | 1 | 32 |
| Collection System | - | 25 | 105 | 29 | - | 159 |
| Total | 5 | 67 | 186 | 37 | 5 | 300 |

11.6.1 Capital Improvement Plan by Phase

This section summarizes the CIP information for each facility in the context of near-term, mid-term and long-term. Additional details for each facility are located in their respective chapters.

11.6.1.1 Near-Term CIP (2018-2020)

The near-term CIP total is approximately \$1,484 million. The near-term CIP consists primarily of collection system CIPs and In-Progress Projects, as shown in Figure 11.5.

Planned improvements to the collection system account for 43% of the planned near-term CIP costs. The next highest category, In-Progress Projects, consist of almost 21% of the planned near-term costs.

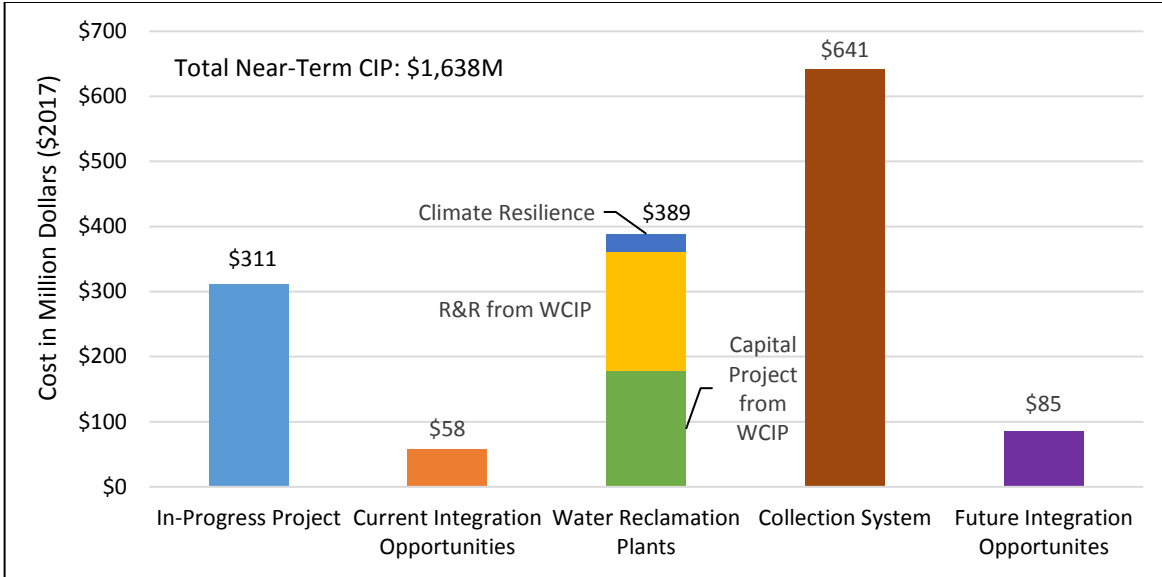

Figure 11.5 Near-Term CIP Summary

The near-term CIP for the WRPs consist of capital projects and replacement and rehabilitation projects identified from the WCIP, estimated at \$178 million and \$184 million, respectively. The climate resiliency portion of the cost is estimated to be \$27 million. The large estimated WRP capital project cost is primarily due to the Interim Ozone Project at DCTWRP. The large planned cost for replacement and rehabilitation WRP projects is typically expected for the near-term phase, as WRPs have greater definition of required rehabilitation projects. The current integration opportunities cost are associated with the Rancho Park WRF, as discussed previously in Section 11.4. One of the future integration opportunities (Concept Option #22 – East-West Valley Interceptor Sewer) could be implemented in the near-term phase.

11.6.1.2 Mid-Term CIP (2021-2030)

The improvements classified as mid-term are those that could be implemented between 2021 and 2030. The mid-term CIP includes costs for In-Progress Projects, WRPs, and the collection system, as shown in Figure 11.6.

The mid-term CIP totals approximately \$700 million. The CIP for the WRPs comprises approximately 49% of the total costs that could be implemented in the mid-term phase. Of the \$345 million planned for the WRPs, \$115 million is estimated replacement and rehabilitation projects from the WCIP. Capital projects from the WCIP consist of \$71 million. The projected costs for the WRPs are based on the methodology described in Section 11.1, and account for \$159 million of cost.

In-Progress Projects for the mid-term are estimated at \$277 million. The In-Progress Projects consist of the GWR Project at DCTWRP and the additional 3.5 mgd expansion of the HAWPF, both which are expected to span both the near and mid-term phases. The mid-

term CIP for the collection system totals \$78 million, and consists primarily of planned replacement and rehabilitation projects.

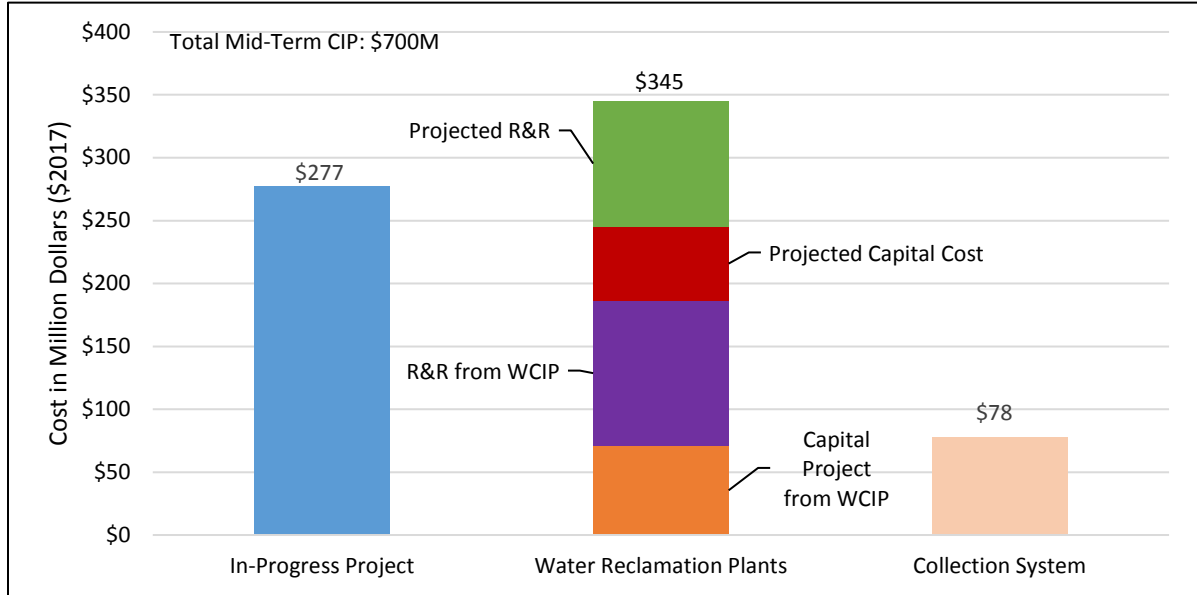

Figure 11.6 Mid-Term CIP Summary

11.6.1.3 Long-Term CIP (2031-2040)

Long-term improvements are those that could be implemented between 2031 and 2040. As expected, there are fewer defined project for the long-term when compared to the near and mid-terms. The prediction of future needs related to new regulations, changing conditions, advancement in technologies and other project drivers is challenging. While there are limitations to providing specificity to future projects, there is a high degree of certainty that there will be evolving needs at each WRP, projects to address these needs, and associated expenditures. As a result, a large portion of the WRP long-term improvements consist of projected values developed per the methodology in Section 11.1.

The long-term CIP consists of costs for the WRPs, collection system, and future integration opportunities, as shown on Figure 11.7. The total CIP cost for the WRPs is estimated at \$1,914 million. This consists of \$10 million for capital projects from the WCIP, \$12 million for replacement and rehabilitation projects identified in the WCIP, and \$14 million for climate resiliency projects. The remaining \$1,878 million consists of projected costs for the WRPs. As only a few long-term projects were specifically identified, projected annual expenditures were estimated for each WRP. These costs represent expenditures for anticipated, but at present undefined, projects.

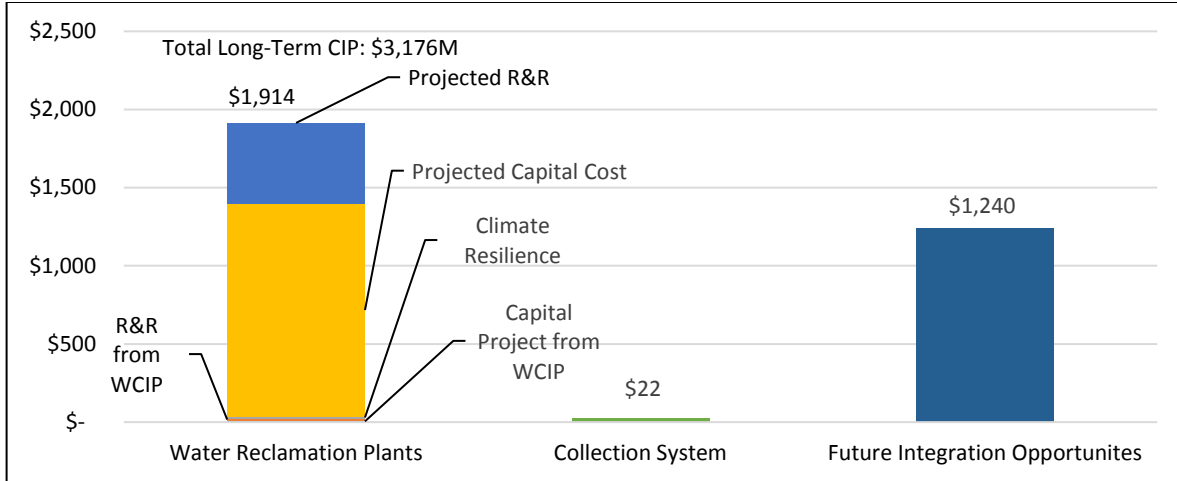

Figure 11.7 Long Term CIP Summary

The future integration opportunities consist of the concept options identified as part of the preferred approach. The cost shown reflects only the identified WWFP portion of the concept option cost. The collection system identifies \$22 million of expected costs in the long-term, consisting of equal amount replacement and rehabilitation projects and climate resiliency projects.

11.7 WASTEWATER FACILITIES ADAPTIVE CIP

The combination of estimated costs for the In-Progress Projects, current integration opportunities, future integration opportunities, and Estimated and Projected CIP, form the basis for the WWFP Adaptive CIP. These projects are summarized by phase (in 2017 dollars) in Table 11.10. This summary is also shown graphically on Figure 11.8 and Figure 11.9. The costs for the future integration opportunities includes the WWFP portion of the costs for Priority A concept options.

| Category | Near-term (2018-2020) (\$M) | Mid-term (2021-2030) (\$M) | Long-term (2031-2040) (\$M) | Total (\$M) |
|------------------------------------------------------------------------------------|-----------------------------------|----------------------------------|-----------------------------------|----------------|
| In Progress Projects | | | | |
| Advanced Treated Recycled Water Delivery to LAX and Scattergood Generating Station | \$38 ⁽¹⁾ | \$92 | | \$130 |
| HWRP Delivery Expansion to 70 mgd for WBMWD and LA Harbor Area | \$16 ⁽²⁾ | | | \$16 |
| Groundwater Replenishment Project with AWPf at DCTWRP | \$185 | \$185 | | \$370 |
| LAGWRP Increase Recycle Water Demand per | \$73 | | | \$73 |

| Table 11.10 WWFP Adaptive CIP Summary Wastewater Facilities Plan One Water LA 2040 Plan | | | | |
|--------------------------------------------------------------------------------------------------------------------------------------------------------------------------------------------------------------------------------------------------------------------------------------------------------------------------------------------------------|-----------------------------------|----------------------------------|-----------------------------------|--------------------|
| Category | Near-term (2018-2020) (\$M) | Mid-term (2021-2030) (\$M) | Long-term (2031-2040) (\$M) | Total (\$M) |
| 2015 UWMP | | | | |
| TIWRP AWP Expansion to 12 mgd | n/a ⁽³⁾ | | | n/a ⁽³⁾ |
| Subtotal | \$311 | \$277 | \$0 | \$589 |
| Current Integration Opportunities | | | | |
| Rancho Park WRF | \$58 ⁽⁴⁾ | | | \$58 |
| Subtotal | \$58 | | | \$58 |
| Water Reclamation Plants | | | | |
| Capital Project from WCIP | \$178 | \$71 | \$10 | \$259 |
| Replacement & Rehabilitation from WCIP | \$184 | \$115 | \$12 | \$311 |
| Climate Resiliency Projects | \$27 | | \$14 | \$41 |
| Projected Capital Project | | \$59 | \$1,360 | \$1,419 |
| Projected Replacement & Rehabilitation Project | | \$100 | \$518 | \$618 |
| Subtotal | \$389 | \$345 | \$1,914 | \$2,648 |
| Collection System | | | | |
| Collection System | \$641 | \$78 | \$22 | \$741 |
| Subtotal | \$641 | \$78 | \$22 | \$741 |
| Future Integration Opportunities (WWFP Cost Element) | | | | |
| Concept Option #13 (MBR at HWRP to Regional System) | | | \$900 | \$900 |
| Concept Option #15 (DCTWRP to LA Aqueduct Filtration Plant) | | | \$220 | \$220 |
| Concept Option #17 (LAGWRP to Headworks Reservoir) | | | \$120 | \$120 |
| Concept Option #22 (East-West Valley Interceptor Sewer) | \$85 | | | \$85 |
| Subtotal | \$85 | \$0 | \$1,240 | \$1,325 |
| Total | \$1,484 | \$700 | \$3,176 | \$5,360 |
| Notes: | | | | |
| (1) Cost of phase 1 of this project is estimated at \$38 million, scheduled to occur in the near-term. Expansion of additional 3.5 mgd (product water) could occur in the mid-term, for an estimated capital cost of \$92 million for a total capital cost of \$130 million. For conservative cost estimations, the expansion was included in the CIP. | | | | |
| (2) An additional cost of \$400 million could be incurred in the future should 70 mgd of MBR treatment be installed at HWRP. | | | | |
| (3) TIWRP Expansion to 12 mgd was completed during the finalization of the WWFP. For this | | | | |

| Table 11.10 WWFP Adaptive CIP Summary Wastewater Facilities Plan One Water LA 2040 Plan | | | | |
|--------------------------------------------------------------------------------------------------------|-----------------------------------|----------------------------------|-----------------------------------|----------------|
| Category | Near-term (2018-2020) (\$M) | Mid-term (2021-2030) (\$M) | Long-term (2031-2040) (\$M) | Total (\$M) |
| reason, it has not been included in the total cost of the In-Progress Projects. | | | | |
| (4) Rancho Park WRF project costs are currently being refined. | | | | |

As shown on Figure 11.8, the total Adaptive CIP for the near-term totals, \$1,484 million, the mid-term totals \$700 million and the long-term totals \$3,176 million.

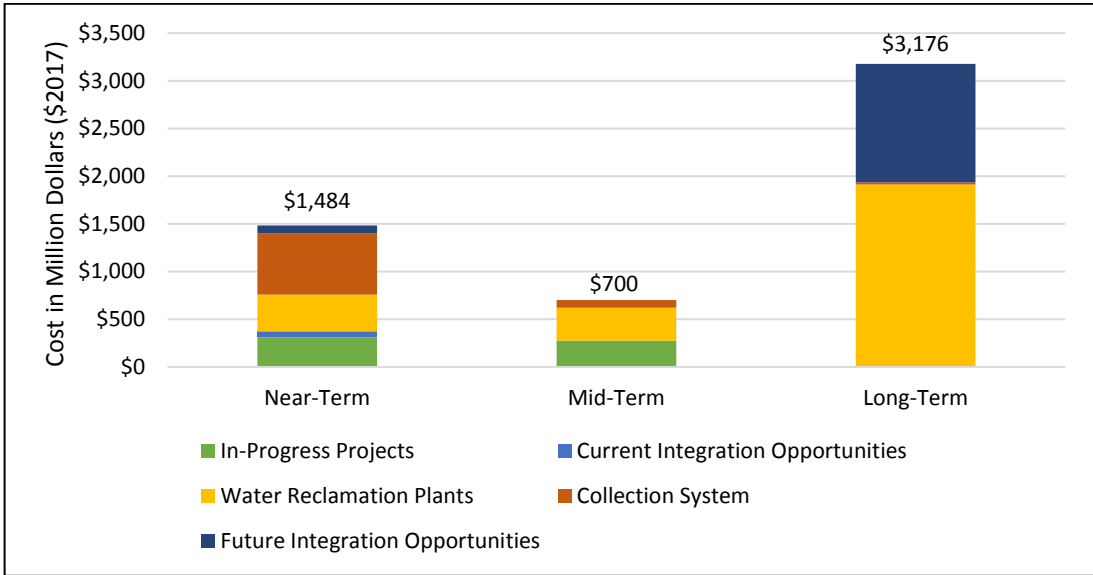

Figure 11.8 Wastewater Facilities Plan Adaptive CIP Summary by Phase

The largest portion of the CIP per phase is in the long-term (2031-2040), as shown in Table 11.10 and Figure 11.8. This is driven by both the future integration opportunities as well as the projected capital and replacement and rehabilitation project estimates.

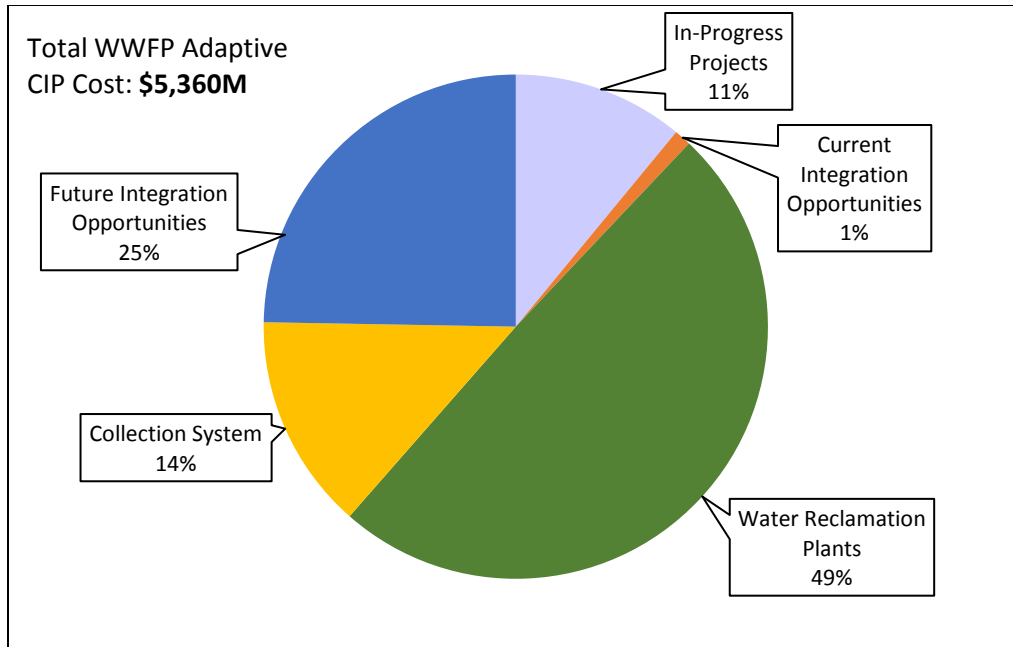

Figure 11.9 WWFP Adaptive CIP by Category

Figure 11.9 shows the largest portion of the total WWFP Adaptive CIP is to be spent on the capital and replacement and rehabilitation projects.

11.8 ESCALATED CIP

This section provides the methodology and budgetary figures for an “escalated” Adaptive CIP. Estimates of costs are presented for the wastewater facilities categories previously discussed:

- In-Progress Projects
- Current integration opportunities
- Future integration opportunities
- Estimated and Projected CIP

The estimates of costs for each of these project categories were developed in 2017 dollars. Recognizing that the City will not implement all projects identified at once, costs for the near-term, mid-term and long-term projects were adjusted to account for inflation, escalated at a rate of 3 percent per year.

To compare costs between different implementation phases, the project costs were then brought back to a present value using a discount rate of 2 percent per year. Discounting the escalated costs yields a net present value and reflects the future escalated values of near – term, mid-term, and long-term projects in today's 2017 dollars. These escalation and

discount factors were determined based on industry standards and are consistent with other One Water LA documents. Figure 11.10 presents a comparison of the estimated costs per implementation phase, highlighting the future cost of money.

Figure 11.10 shows the total WWFP Adaptive CIP is \$6,062 million over a 20 plus year timeframe, which translates to \$263 million per year. The near-term planning phase shows a total of \$1,519 million or \$506 million per year. The mid-term planning phase shows a total of \$757 million or \$75.7 million per year. The long-term planning phase shows a total of \$3,786 million or \$378.6 million per year.

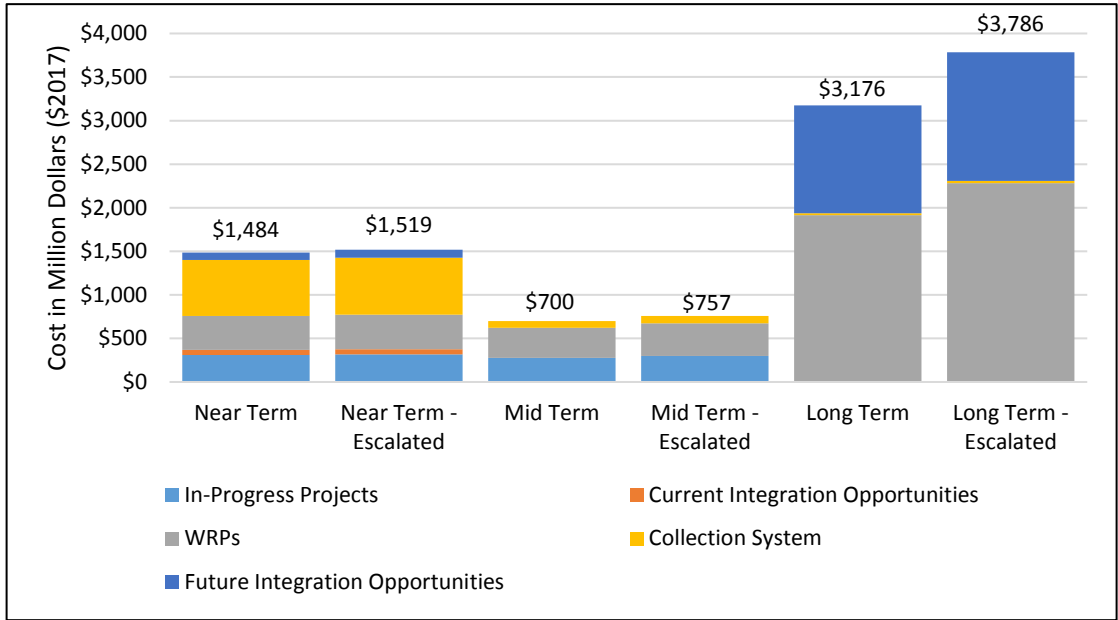

Figure 11.10 CIP Comparison of Net Present Values

The projected annual rate of CIP expenditures is the highest for the long-term. This is due to the estimates that were made for the long-term projected CIP. The mid-term presents the lowest rate of annual expenditures, with the near-term projected between the mid and long-term annual projected expenditures.

Figure 11.11 shows a proposed timeline for this WWFP Adaptive CIP. The durations are estimated based on the Adaptive CIP and the development of the In-Progress Projects and concept options. Figure 11.11 provides information on when specific expenditures may be incurred for the CIP projects.

| Timeline for Wastewater Facilities Plan | Near-Term | | | Mid-Term | | | | | | | | | | Long-Term | | | | | | | | | |
|-----------------------------------------------------------------------|-----------|-------|--------|----------|------|------|------|--------|------|------|------|------|------|-----------|-------|------|------|------|------|------|------|------|--------|
| | 2018 | 2019 | 2020 | 2021 | 2022 | 2023 | 2024 | 2025 | 2026 | 2027 | 2028 | 2029 | 2030 | 2031 | 2032 | 2033 | 2034 | 2035 | 2036 | 2037 | 2038 | 2039 | 2040 |
| In-Progress Projects | | | | | | | | | | | | | | | | | | | | | | | |
| Hyperion AWWP to LAX and Scattergood ⁽¹⁾ | \$38M | | | \$92M | | | | | | | | | | | | | | | | | | | |
| LAGWRP NPR Expansion | \$73M | | | | | | | | | | | | | | | | | | | | | | |
| HWRP Delivery Expansion to 70 mgd for WBMWD and Harbor ⁽²⁾ | \$16M | | | | | | | | | | | | | | | | | | | | | | |
| GWR with AWWP at DCTWRP | | | \$370M | | | | | | | | | | | | | | | | | | | | |
| Current Integration Opportunities | | | | | | | | | | | | | | | | | | | | | | | |
| Rancho Park WRF | \$58M | | | | | | | | | | | | | | | | | | | | | | |
| Water Reclamation Plants | | | | | | | | | | | | | | | | | | | | | | | |
| Capital Projects from WCIP | \$178M | | | \$71M | | | | | | | | | | | \$10M | | | | | | | | |
| R&R from WCIP | \$184M | | | | | | | \$115M | | | | | | | \$12M | | | | | | | | |
| Climate Resiliency Projects | | \$27M | | | | | | | | | | | | | \$14M | | | | | | | | |
| Projected Capital Project | | | | \$59M | | | | | | | | | | | | | | | | | | | \$136M |
| Projected R&R Projects | | | | \$100M | | | | | | | | | | | | | | | | | | | \$518M |
| Collection System | | | | | | | | | | | | | | | | | | | | | | | |
| Collection System | \$641M | | | | | | | \$78M | | | | | | | \$22M | | | | | | | | |
| Future Integration Opportunities | | | | | | | | | | | | | | | | | | | | | | | |
| #22 East-West Valley Interceptor Sewer | \$85M | | | | | | | | | | | | | | | | | | | | | | |
| #15 DCTWRP to LA Aqueduct Filtration Plant | | | | | | | | | | | | | | | | | | | | | | | \$220M |
| #17 LAGWRP to Headworks Reservoir | | | | | | | | | | | | | | | | | | | | | | | \$120M |
| #13 MBR at HWRP to Regional System | | | | | | | | | | | | | | | | | | | | | | | \$900M |

(1) The estimated capital cost is for the installation of a 5 mgd facility, the Phase 1 cost of \$38M is included in the \$130M.

(2) An additional cost of \$400 million could be incurred in the future should 70 mgd of MBR treatment be installed at HWRP.

(3) TIWRP Expansion to 12 mgd was completed during the finalization of the WWFP. For this reason, it has not been included in the total cost of the In-Progress Projects.

Figure 11.11 – Timeline for Wastewater Facilities Plan

One Water LA 2040 Plan



-This Page Left Blank Intentionally-

Appendix A
REFERENCES

LABOE 2016 Master Schedule, September 2016

LABOE Engineering projects information website, <http://eng.lacity.org/iuprs/>

LABOE, Task Order Solicitation No. 35 Design build documents for the DCT In-Plant Storage Project and development of BOE Design Build Policies and Procedures, July 2008

LABOE Uniform Project Reporting System, <http://eng.lacity.org/iuprs/>, May 6, 2016.

LADWP, Draft Environmental Impact Report: Los Angeles Groundwater Replenishment Project, May 2016

LADWP, Urban Water Management Plan. 2015.

LADWP/LASAN, Recycled Water Master Planning documents, October 2012.

LADWP/LASAN, TIWRP Barrier Supplement and Non-Potable Reuse Concepts Report, March 2012.

LADWP/LASAN, Water IRP 5-Year Review Final Documents, June 2012.

LASAN/LADWP, City of Los Angeles Integrated Resources Plan, December 2006.

LASAN, Amended Engineering Report for the Terminal Island Water Reclamation Plant Advanced Water Purification Facility Expansion: Dominguez Gap Barrier Project, August 2015.

LASAN (prepared by Arcadis), East West Valley Interceptor Sewer (EWVIS) Concept Report, January 2017

LASAN (prepared by Arcadis), East West Valley Interceptor Sewer (EWVIS) Planning Study, December 2015

LASAN, Final Environmental Impact Report for Hyperion Treatment Plant Digester Gas Utilization Project: Power and Steam Generation, August 2013

LASAN, Hyperion Treatment Plant Operation Manual, March 2011

LASAN, Monthly Performance Reports, 2013-2015.

LASAN, Wastewater Capital Improvement Program: Fiscal Years 2015/6 – 2024/5, July 2015.

Los Angeles Regional Water Quality Control Board (Regional Board), 2017, Order No. R4 2017-0045 NPDES Permit No. CA 0109991, April 1, 2017.

Los Angeles Regional Water Quality Control Board (Regional Board), 2017, Order No. R4 2017-0062 NPDES Permit No. CA 0056227, May 1, 2017.

Los Angeles Regional Water Quality Control Board (Regional Board), 2017, Order No. R4 2017-0063 NPDES Permit No. CA 0053953, May 1, 2017.

Los Angeles Regional Water Quality Control Board (Regional Board), 2012, Order No. R4 2015-0119 NPDES Permit No. CA 0053856, June 11, 2015.

Mayors Executive Directive No. 5, October 2014.

MWD Water Supply Strategy, 2016.

Terminal Island Water Reclamation Plant Advanced Water Purification Facility Operation Optimization Plan Draft, October 2016.

Discussions with Plant Staff.

Sources

Black & Veatch Corporation (2010) White's Handbook of Chlorination and Alternative Disinfectants, 5th Edition, John Wiley & Sons, Inc., Hoboken, New Jersey.

Edzwalkd, J.K., and J. Haarhoff (2012) Dissolved Air Flotation for Water Clarification, McGraw-Hill. New York.

Grady, C.P.L., Jr., G.T. Daigger, N.G. Love and C.D.M. Filipe (2011) Biological Wastewater Treatment, 3rd Edition, CRC Press, Boca Raton, FL.

Hammer, M. J., Hammer, M. J., Jr., (2012) Water and Wastewater Technology, 7th Edition, Pearson/Prentice-Hall, Upper Saddle River, NJ.

John C. Crittenden, R. Rhodes Trussell, David W. Hand, Kerry J. Howe, George Tchobanoglous (2012) Water Treatment: Principles and Design, 3rd Edition, John Wiley & Sons, Inc., New York.

NWRI (2012) Ultraviolet Disinfection Guidelines for Drinking Water and Water Reuse, 3rd Edition, Updated Edition, National Water Research Institute, Fountain Valley, CA.

Qasim, S. (1999) Wastewater Treatment Plants, Planning, Design and Operations, 2nd Edition, Technomic Publishing Co., Lancaster, PA.

Tchobanoglous, G., F.L. Burton, and H.D. Stensel (2013) Wastewater Engineering: Treatment and Reuse, 5th Edition, McGraw-Hill, New York.

Tchobanoglous, G., F.L. Burton, and H.D. Stensel, & Metcalf and Eddy (2014) Wastewater Engineering Treatment and Resource Recovery, 5th Edition, McGraw-Hill, New York.

WEF (2012) Solids Process Design and Management, Water Environment Federation, Alexandria, VA.

-This Page Left Blank Intentionally-

COLLECTION SYSTEM SUPPLEMENTAL INFORMATION

B.1 CONDITION ASSESSMENT PROGRAMS

Implementation of the planned projects above will provide relief for constricted areas of the existing collection system infrastructure. However, constant monitoring of the remaining infrastructure is required to determine changing structural and hydraulic conditions.

The City's condition assessment program monitors structural and hydraulic conditions of the collection system through various programs. Deficiencies are identified and any needed improvements are developed and implemented systematically as part of the City's sewer rehabilitation and replacement plan. This section provides a summary of these conditions assessments for the major part of the sewer system.

B.1.1 Closed Circuit Television

The City rates the condition of its sewers in an ongoing CCTV condition assessment program using state-of-the-art CCTV equipment. The CCTV condition assessment program monitors the condition of the collection system in a step-by-step process of televising, reviewing, ranking, and reporting. Sewers are inspected in a priority order using a ranking system that incorporates age, size, construction material, overflow history, and known problems. On average, the City performs CCTV inspection on 400 miles of sewers per year. From the 2012 – 2017 calendar years, a total of approximately 1,951 miles of secondary sewer CCTV was reviewed, averaging 390 miles per year. To rate the condition of CCTV inspected sewers, the City uses a five category system based on the types and severity of defects. The Categories range from Category A (Very Good) to Category E (Emergency Condition); the condition of a sewer is ranked according to Table B.1. The condition rating relates to probability of failure only. Once sewers in need of immediate relief are packaged into a rehabilitation and/or replacement project, the entire project is then scored using 8 criteria that cover both probability and consequence of failure to prioritize Wastewater Capital Improvement Program (WCIP) funds.

| Table B.1 Sewer Condition Ranks Wastewater Facilities Plan One Water LA 2040 Plan | | |
|--------------------------------------------------------------------------------------------------|-----------------------------------------------------------------------------------------------------|------------------------------------------------|
| Category | Condition Description | Action Identified |
| A | Very Good <ul style="list-style-type: none"> Condition is almost like new sewer pipe | No repairs needed Future routine inspection |
| B | Good to Fair Condition <ul style="list-style-type: none"> Light cracks localized | No immediate repairs needed |

| Table B.1 Sewer Condition Ranks Wastewater Facilities Plan One Water LA 2040 Plan | | |
|--------------------------------------------------------------------------------------------------|---------------------------------------------------------------------------------------------------------------------------------------------------------------------------------------------------------------------------------------|------------------------------------------------------------------------------------------------------------------------------------------------------------------------------------------|
| Category | Condition Description | Action Identified |
| | <ul style="list-style-type: none"> • Light corrosion localized • Light roots localized | Possible preventive measures such as chemical addition, other treatment, or maintenance to stabilize existing condition. Schedule next inspection in the order of sewer system priority. |
| C | Fair to Poor Condition <ul style="list-style-type: none"> • Moderate cracks/fractures • Moderate corrosion continuous • Moderate infiltration continuous • Moderate roots continuous | Continuous monitoring Continue monitoring structural condition every five years as scheduling priority allows. Possible preventive measure. |
| D | Very Poor Condition <ul style="list-style-type: none"> • Severe cracks/fractures • Broken pipe with holes • Severe corrosion • Severe infiltration/roots | Expedite Repairs Includes planning, environmental documentation, technical investigation, design, reviews, bid and award following established priorities. |
| E | Emergency Condition <ul style="list-style-type: none"> • Collapsed pipe/street • Dirt in Pipe • Crown of pipe gone • Voids in backfill • Full flow obstruction/blockage | Emergency Repair Initiate Special Order Procedure under "Urgent Necessity" clause |







As shown in Table B.1, the condition ratings trigger a follow-up action that includes either rehabilitation within a certain time frame or a follow-up inspection. Any sewers with a condition rank of "D" (if applicable) are addressed as priorities for rehabilitation or replacement through the WCIP and sewers with a condition rank of "E" are addressed immediately through emergency projects.

A summary of CCTV inspection of the sewer outfalls is shown in Table B.2 and Figure B.1. As indicated on the table and map, major parts of the outfall system are ranked as condition A or B, which means they are in good condition - requiring no immediate attention. Parts of the NOS and most of the Central Outfall Sewer (COS) are ranked as condition C or D, requiring rehabilitation or repair. Rehabilitation of the West Los Angeles Interceptor Sewer (WLAIS) and sections of the COS and La Cienega Interceptor Sewer (LCIS) have been completed. Projects to rehabilitate or replace the other D ranked sections are planned and underway.

| Table B.2 Summary of CCTV Inspection of Sewer Outfalls Wastewater Facilities Plan One Water LA 2040 Plan | | | | | | | | | |
|-------------------------------------------------------------------------------------------------------------------------|------------------------------|---------------------------------------------------------|-------------|-------------|-------------|-------------|---------------------------------------|-------------------------------------|-----------------------|
| Outfall Name | System Length (miles) | CCTV Inspected Condition Category Length (miles) | | | | | Total Length Inspected (miles) | % of System Length Inspected | Year Installed |
| | | A | B | C | D | E | | | |
| AVORS | 10.0 | 6.4 | 0.3 | 0.0 | 0.0 | 0.0 | 6.7 | 67.0 | 1964-1975 |
| CIS | 10.7 | 5.2 | 0.5 | 0.0 | 0.0 | 0.0 | 5.7 | 53.3 | 1926-2001 |
| COS | 10.1 | 1.2 | 1.9 | 3.3 | 2.1 | 0.0 | 8.5 | 84.2 | 1904-1996 |
| ECIS | 11.8 | 0.0 | 0.0 | 0.0 | 0.0 | 0.0 | 0.0 | 0.0 | 2000-2005 |
| ERIS | 3.9 | 0.3 | 0.0 | 0.0 | 0.0 | 0.0 | 0.3 | 7.7 | 1999-2004 |
| EVIS | 8.9 | 7.4 | 0.2 | 0.0 | 0.0 | 0.0 | 7.6 | 85.4 | 1975-1991 |
| EVRS | 7.1 | 4.9 | 0.5 | 0.0 | 0.0 | 0.0 | 5.4 | 76.1 | 1981 |
| LCIS | 8.8 | 1.5 | 2.8 | 1.6 | 0.7 | 0.0 | 6.6 | 75.0 | 1924-1995 |
| LCSFVRS | 12.2 | 7.1 | 0.0 | 0.0 | 0.0 | 0.0 | 7.1 | 58.2 | 1953-1967 |
| NCOS | 8.0 | 2.3 | 1.2 | 0.0 | 0.0 | 0.0 | 3.5 | 43.8 | 1956-1987 |
| NEIS | 5.3 | 0.0 | 0.0 | 0.0 | 0.0 | 0.0 | 0.0 | 0.0 | 2001-2008 |
| NHIS | 2.4 | 0.0 | 0.0 | 0.0 | 0.0 | 0.0 | 0.0 | 0.0 | 2001-2002 |
| NORS | 9.3 | 0.3 | 0.1 | 0.0 | 0.0 | 0.0 | 0.4 | 4.3 | 1987-1996 |
| NOS | 58.0 | 19.3 | 12.3 | 5.4 | 8.3 | 0.0 | 45.3 | 78.1 | 1923-2005 |
| VORS | 15.3 | 11.9 | 0.6 | 0.03 | 0.0 | 0.0 | 12.5 | 81.9 | 1951-1973 |
| WHIS | 7.7 | 6.6 | 0.1 | 0.0 | 0.0 | 0.0 | 6.7 | 87.0 | 1972-1975 |
| WLAIS | 4.2 | 2.3 | 0.5 | 0.1 | 0.1 | 0.0 | 3.0 | 71.4 | 1925-1949 |
| WRS | 4.8 | 3.5 | 0.3 | 0.0 | 0.0 | 0.0 | 3.8 | 79.2 | 1962-1996 |
| Total (miles) | 198.5 | 80.2 | 21.3 | 10.4 | 11.2 | 0.00 | 123.1 | -- | -- |
| % | -- | 65.2 | 17.3 | 8.5 | 9.1 | 0.00 | -- | 62.0 | -- |
| Note: | | | | | | | | | |
| (1) Updated: 2017 | | | | | | | | | |

Figure B.1
Outfall System Physical
Condition
One Water LA 2040 Plan



-  WRP
- CCTV Rank**
-  A
-  B
-  C
-  D
-  No CCTV
-  Rehabbed

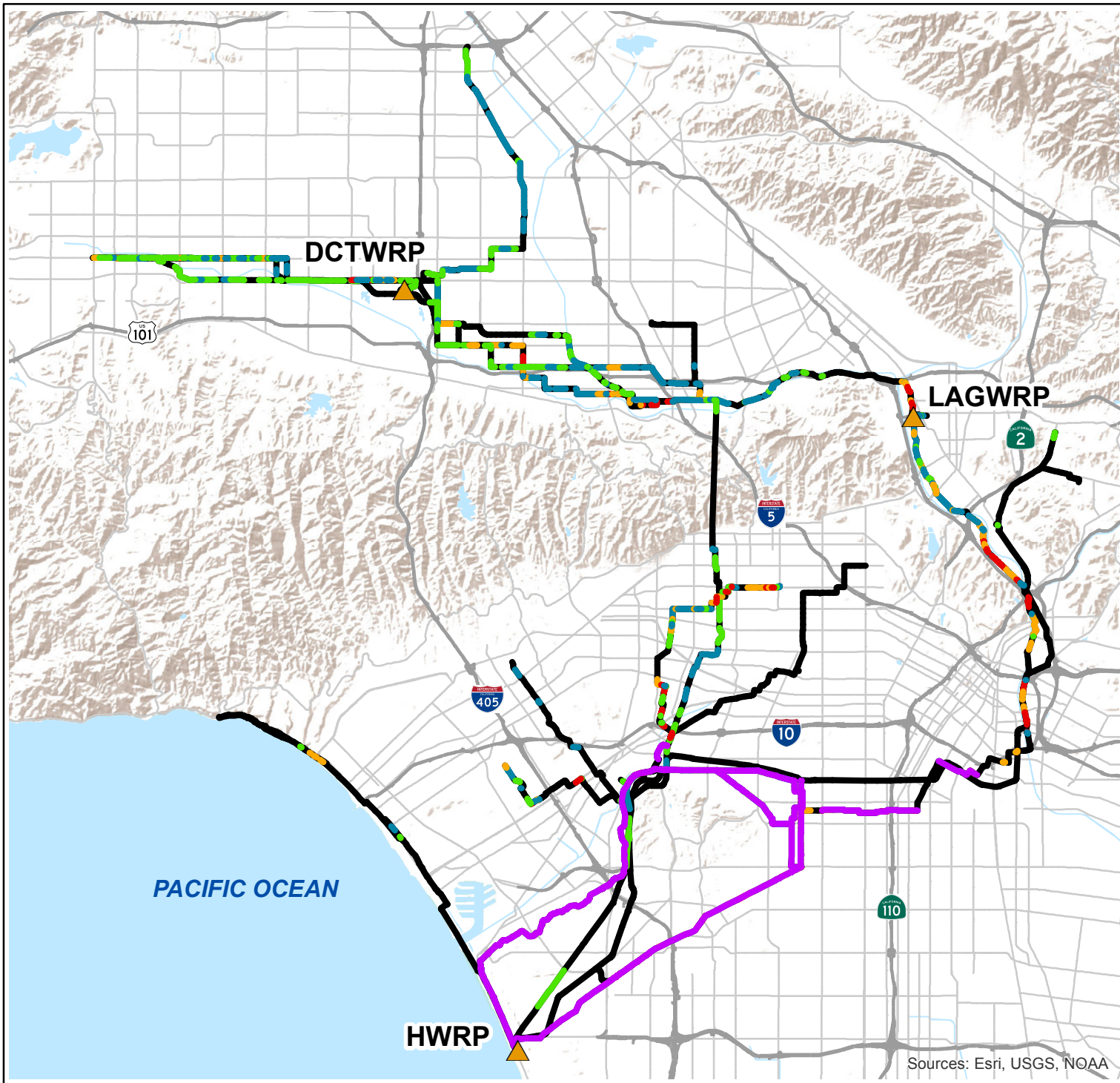
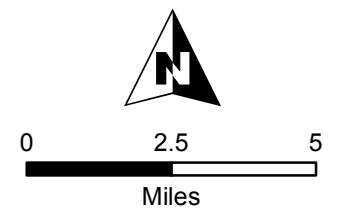

Sources: Esri, USGS, NOAA

B.1.2 Flow Monitoring

The existing hydraulic condition of the wastewater collection system is also evaluated through the Flow Monitoring Program which monitors the actual hydraulic conditions throughout the City. The program utilizes a combination of near-time, periodic, and special gauges.

Near-time gauges (approximately 190 gauges) are used to continuously monitor pipe flow depth and average velocity in major outfalls, interceptors, and selective primary sewers. Data is recorded in 5- to 15-minute intervals. Flow data is transmitted to a web-based system that allows for simultaneous monitoring and analysis. Depth is measured as the water level relative to the hard surface below (i.e. pipe invert or sediment). Sediment is measured during installation and is removed from the raw readings.

Periodic gauges are used to monitor short-term flows at 550 to 700 primary and secondary sewers. The gauges only record depth at 15-minute intervals. Flow data is recorded over one to seven days and is manually stored for future analysis.

Special gauges are similar to periodic gauges and are reserve gauges that can be used to monitor flows in cases where additional flow gauging is needed under special circumstances (e.g. prior to sewer construction, or where no recent or valid flow data is available). The gauges only record flow depth and can be used to monitor flows over one to 14 days.

The Flow Gauging Program is a critical tool for the development and maintenance of the MU model. Flow data collected throughout the City's collection system is continuously compared to the model simulated conditions. Any major discrepancies in the hydrodynamic model are then addressed through a calibration process. This allows the City to maintain a highly reliable and predictive model. The model is then used to predict future hydraulic conditions in order to anticipate future relief projects.

Figure B.2 and Figure B.3 show the HSA and TISA near-time monitoring locations, respectively.

Flow monitoring and CCTV inspection records utilized as tools to help identify deficiencies. These structural and hydraulic condition assessment tools allow the City to conduct comprehensive and systematic inspections and assessments of all components of its sewer system.

Figure B.2
HSA Flow
Monitoring Locations
One Water LA 2040 Plan



- Active Gauge
 - Inactive Gauge
 - ▲ WRP
 - Outfalls
 - Primary Sewer
- Sewersheds**
- Various Colors

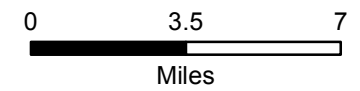
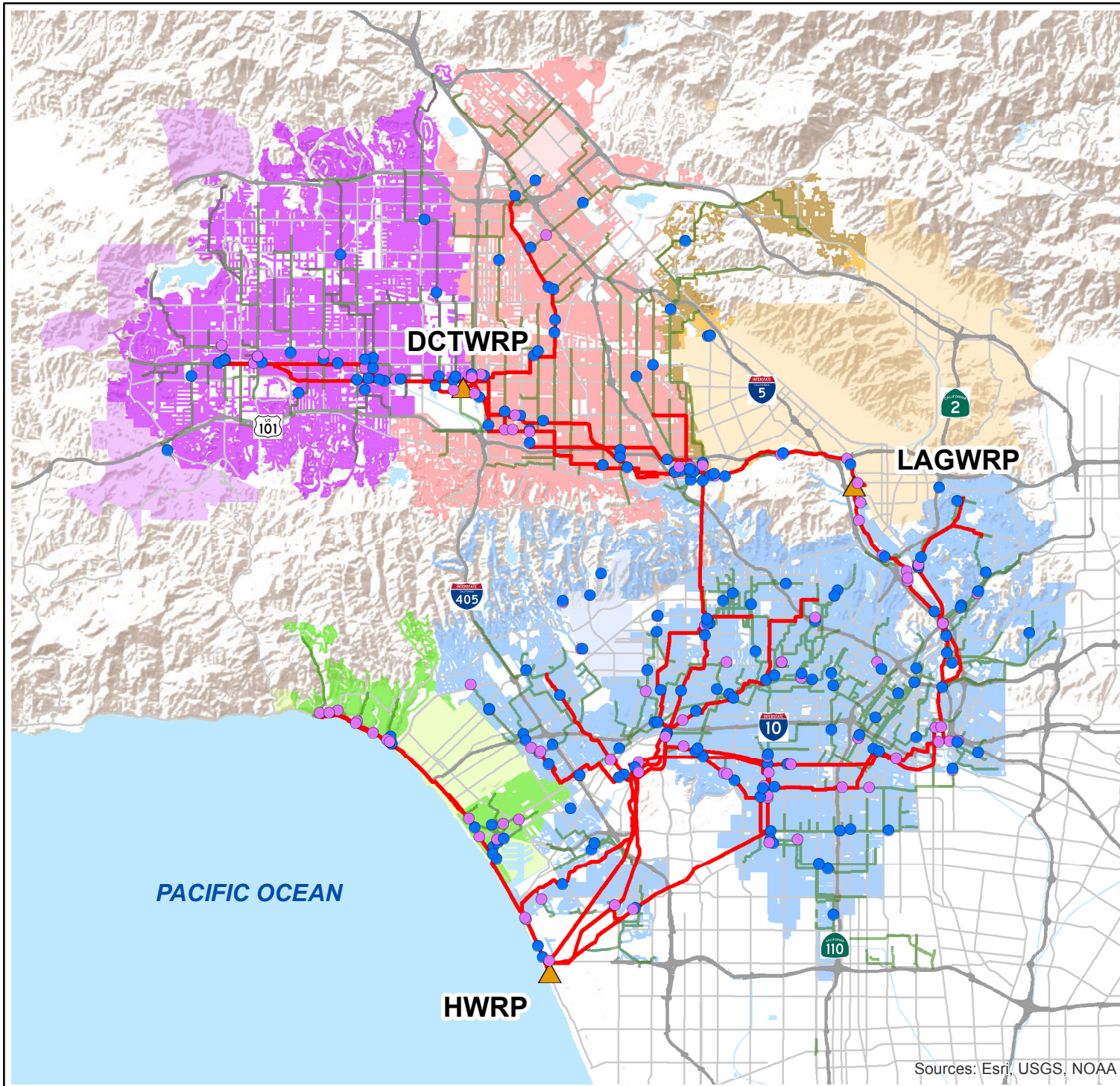

Sources: Esri, USGS, NOAA

**Figure B.3
TISA Flow
Monitoring Locations**
One Water LA 2040 Plan



- Active Gauge
- Inactive Gauge
- ▲ WRP
- Force Main
- Primary Sewer
- Secondary Sewer
- Sewershed

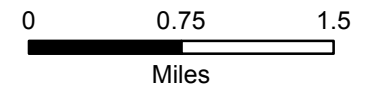

Sources: Esri, USGS, NOAA

B.2 WASTEWATER COLLECTION SYSTEM PROGRAMS

In addition to the Condition Assessment Programs, the City utilizes other programs to address the needs of the wastewater collection system.

B.2.1 Sewer Infiltration and Inflow Prevention

Wastewater flow consists of three basic components: 1) sanitary flow, 2) industrial flow, and 3) inflow/infiltration (I/I). Sanitary flow is the normal wastewater flow component generated by residential and commercial users. Industrial flow is any wastewater that is generated from manufacturing and industrial processes, and is regulated through Industrial Wastewater Discharge Permits. I/I is groundwater and stormwater runoff that enters the collection system directly or indirectly through defects in the pipelines and maintenance holes.

Indirect sources (infiltration) include defective pipe, open or cracked joints, and deteriorated maintenance hole walls. This type of extra flow occupies pipeline capacity that is normally available for sanitary flow. Sources that allow entry of stormwater (inflow) include connected downspouts, maintenance hole covers, area or yard drains, and catch basins. The amount of I/I can vary widely depending on location, system age, structural integrity, and intensity of rainfall. Sufficient allowance for adequate peak I/I capacity is critical to the ultimate performance of collection and treatment facilities.

The entry of groundwater and stormwater runoff into the wastewater collection system increases the costs of operating wastewater conveyance and treatment facilities. Furthermore, stormwater entry combined with existing wastewater flows can exceed pipeline capacity. When this occurs, low-lying houses flood, and wastewater spills out of the system through maintenance holes.

To address this problem, the City established an I/I Reduction Program to identify and mitigate areas where there is a cost benefit to implement I/I reduction capital projects, such as pipe rehabilitation. The major components of the program include:

- Monitoring flow to establish flow characteristics for individual drainage basins;
- Developing design flows based on flow monitoring data and future population projections;
- Estimating costs for finding and correcting I/I sources;
- Analyzing the hydraulic capacity of the system, to calculate I/I savings and to identify basins where I/I reduction is cost-effective;
- Developing a structured I/I correction and capacity correction program; and
- Collection System Maintenance Program.

The I/I Reduction Program includes a provision for long-term collection system maintenance. A comprehensive maintenance program continues I/I correction activities after cost-effective rehabilitation projects are complete. As the collection system ages, additional defects will

develop, allowing additional I/I into the system. If no action is taken, system surcharging will increase with time, along with an increased risk of sewage overflows.

Major activities in a collection maintenance program include testing and inspection, routine system rehabilitation, cyclic replacement, routine maintenance activities such as pipeline cleaning and root control, and related data management functions. These activities can be incorporated into the City's current maintenance program with the emphasis directed at I/I sources. The presence of I/I is a reliable indicator of potential structural and maintenance problems.

B.2.2 Wet Weather Preparedness and Operation Plan

As discussed above, inflow and infiltration is one of the basic components of wastewater flows. I/I can be dry-weather runoff that enters the collection system through unsealed maintenance holes, or groundwater that enters through defects or cracks in pipes, maintenance holes, and joints. During a wet-weather event, additional Rainfall-derived Infiltration and Inflow (RDII) enters the collection system through unsealed maintenance holes. The volume of RDII is dependent on the intensity of the storm event. During a severe storm event, the extent of RDII can overwhelm the conveyance capacity of the collection system, causing sanitary sewer overflows.

In order to prevent sanitary sewer overflows and protect public health and the environment during severe storm events, the City developed the Wet Weather Preparedness and Operation Plan (WWPOP). The WWPOP directs various LASAN division managers to perform various actions prior to, during, and after a severe storm event. The WWPOP also officially designates a person in charge, "storm commander", to coordinate division activities, track progress of the storm event, ensure all parties are performing their duties, and to manage the collection system and treatment facilities within the pre-authorized limits outlined in the WWPOP. However, significant changes must be cleared and approved by LASAN's Chief Operating Officer.

The major components and tasks of the WWPOP include:

- Reduce or eliminate wet weather overflows from the City's wastewater collection and treatment systems through:
 - Inspecting and maintaining all essential and backup components of the wastewater facilities including the sewage collection system piping, pumping plants, and the four water reclamation plants
- Maximizing the use of the existing collection system and the treatment facilities
- Maintain stable operation of all water reclamation plants during wet weather operation by:
 - Not jeopardizing the treatment process or allowing water reclamation plants to go off-line

- Providing coordination between the water reclamation plants and the collection system to optimize overall system performance.
- Anticipating the need for and providing quick response to control system data and making appropriate adjustments to avoid overflows.
- Performing ongoing responsiveness and preparedness training.
- Reduce and mitigate wet-weather related flooding from the City's Stormwater system (storm drains) through:
 - Inspecting, cleaning, and maintaining all essential and backup components of the stormwater facilities including debris basins, channels, storm drains, catch basins, and pumping plants.
 - Performing ongoing responsiveness and preparedness training.

The City implements a comprehensive sewer infrastructure asset management program that is documented within the components of the Sewer System Management Plan (SSMP), including sewer condition assessment; master plans; repair, rehabilitation, and replacement; capacity assurance; operation and maintenance; source control; and overflow response programs.

B.2.3 Management, Operations, and Maintenance

To manage, operate, and maintain the sewer collection system, the City developed a SSMP and various other manuals to guide staff in the operations of the sewer collection system, frequency of sewer cleaning, and maintenance of pump stations and equipment. The City reviews and updates these plans periodically to check for continued compliance with the State's requirements and effectiveness in addressing spills. The current plans were updated in February 2017 following a biennial internal audit pursuant to the State requirements. These plans include measures to control and mitigate sewer spills and are available to the public.

Tasks and their frequency are determined based on operation and maintenance experience, past performance, manufacturer's recommendations, and site-specific conditions. Scheduled and completed tasks are catalogued and tracked by work orders in a maintenance management system called Enterprise Maintenance Planning and Control (EMPAC). Pump run times are routinely monitored and used in scheduling routine maintenance. The maintenance program includes preventive, proactive, predictive, and corrective maintenance; maintenance engineering; and quality control.

EMPAC is an asset management and maintenance system utilized to manage work orders, track warehouse parts, and streamline maintenance related purchases. The City also uses the Field Automation for Sanitation Trucks (FAST) application to provide field access to EMPAC. FAST greatly reduces the amount of paperwork in collecting closure data for work orders. Work orders are closed in the field, thus reducing data entry by clerks and supervisors. Geographic Information System (GIS) integration ties EMPAC assets to actual

field locations, searchable by street address or intersection. Real-time access to data in the field enables crews to work more efficiently.

B.2.3.1.1 Preventive and Proactive Maintenance

The City has a preventive and proactive maintenance program for its sewer system. Six maintenance yards are strategically located throughout the City to minimize travel time and maximize efficiency. Preventive maintenance is focused on critical and problematic areas. Maintenance is performed by staff assigned to each of the maintenance yards. Problem sewers are identified, prioritized, and scheduled for maintenance based on a comprehensive review of the maintenance history and system characteristics of all the sewers in the City including overflows, blockages, excessive maintenance, age, material, condition, etc. Maintenance includes high velocity sewer cleaning, bucketing, and mechanical and manual rodding of sewers.





Sewers are inspected as soon as possible, usually within 48 hours after the initial occurrence of an overflow, by CCTV to identify any necessary repairs or special maintenance needs. Sewers that exhibit high flow levels or operational failure are identified, and are further reviewed to determine cause and/or immediate corrective actions. Priorities and schedules are based on the severity of the problem. In addition to preventive maintenance, the City implements a proactive maintenance program where "non-problem" sewers are also scheduled for maintenance and cleaning, but on a less frequent basis. Proactive maintenance of secondary sewers is performed on a basin by basin case. The City implements a quality assurance/quality control (QA/QC) program designed to examine the effectiveness of cleaning. After a sewer cleaning, pipes are inspected by CCTV to ensure that cleaning has restored the flow area of the sewer to at least 95 percent of the pipe diameter. Any sewer that fails the inspection is re-cleaned and the crew is retrained on the proper procedures. On average, the City cleans over 6,700 miles of sewers per year.

B.2.3.1.2 Odor Control Program

The City faces a daily challenge in an effort to control and mitigate sewer-related odors. Sewer related odors are caused by sewer ventilation in which foul air is forced out and released from maintenance holes or other sewer structures or facilities such as pumping plants and water reclamation plants. Sewers with debris build-up are more likely to become septic, releasing foul odors that can escape the sewer system. The City maintains odor monitoring locations at strategic locations where parameters associated with sewer odors are measured, recorded, and analyzed. This analysis helps identify areas susceptible to sewer-related odors ("odor hot spots"). The parameters measured include total and dissolved sulfides; pH; temperature; H₂S concentration; air pressure; and historical odor complaints. Areas that experience higher H₂S concentration may be due to longer Hydraulic Retention Time (HRT), increased solids concentration in the wastewater or both. The City's odor monitoring locations are shown on Figure B.4.

Figure B.4
Odor Monitoring
Locations
One Water LA 2040 Plan



-  Odor Monitoring
 -  WRP
 -  Outfalls
 -  Primary Sewer
- Sewersheds**
-  Various Colors

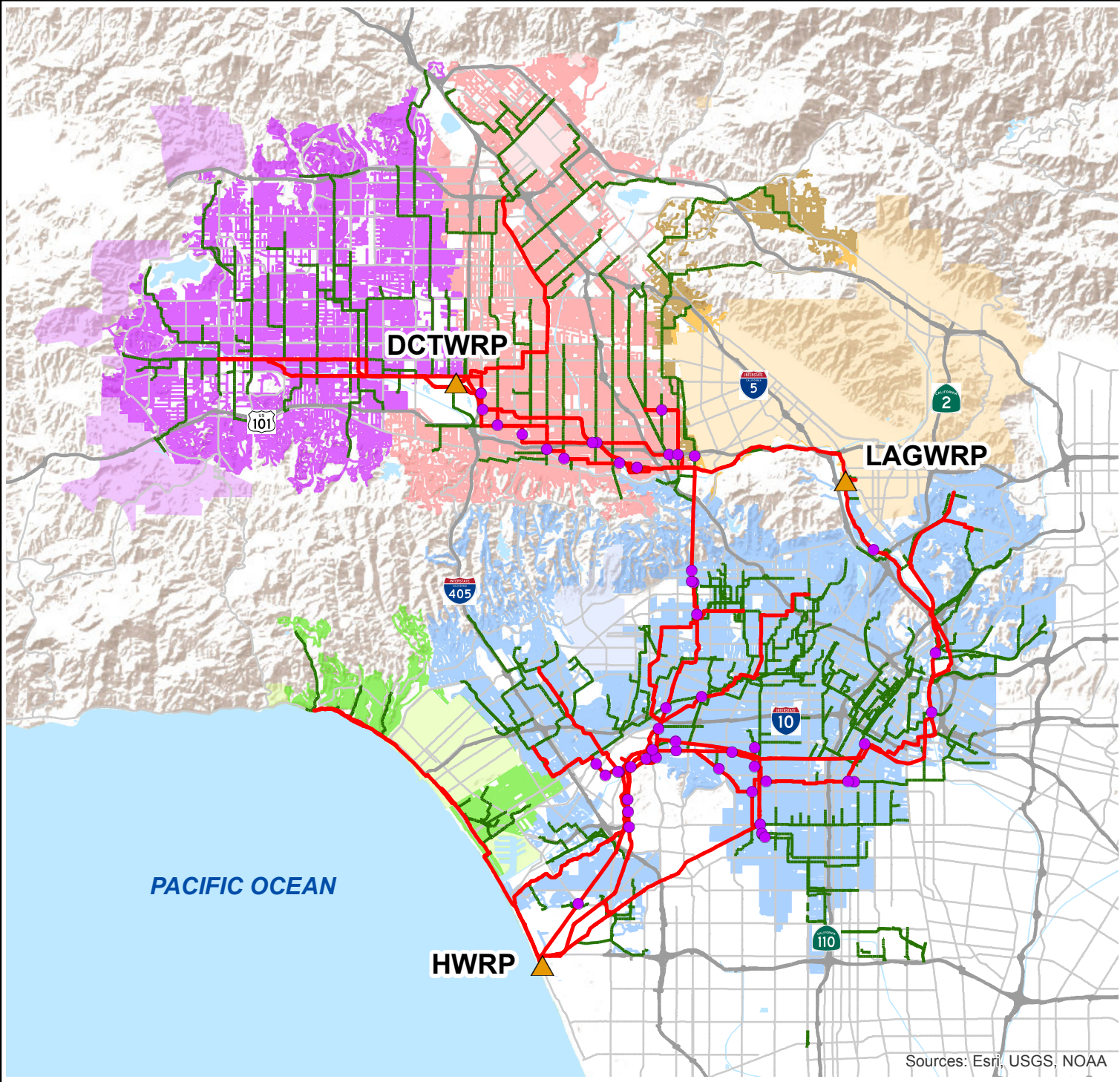

Sources: Esri, USGS, NOAA

The City implemented a successful program to control and reduce odors within its collection system which has made significant improvements. The odor control program utilizes various measures to restrain both the generation and release of odors from the sewer system, which include:

- odor complaint response and investigation;
- routine sewer maintenance;
- chemical addition;
- air withdrawal, treatment and management;
- sealing maintenance holes;
- sewer construction and repair; and
- on-going monitoring of sewer air pressure and odor concentration.









Most odor problems are resolved by regular cleaning. However, some complex odor problems, such as airflow restrictions in a line due to high flow, cannot be resolved by maintenance. In these instances the City will implement site-specific actions, including flow diversions, chemical addition, and the use of relief sewers. The City has also implemented an aggressive, chemical injection program where chemicals (i.e. caustic soda and magnesium hydroxide) are injected into the system at key locations to reduce the levels of hydrogen sulfide, the predominant source of odors. This program has been extremely successful in reducing hydrogen sulfide levels as evidenced by over 90 percent reduction since 1997. The City has also built permanent air treatment facilities (ATFs) at strategic locations along major interceptor sewers to treat foul air. These ATFs capture hydrogen sulfide through the use of fans and treat sewer gases using highly advanced treatment technologies. Figure B.5 shows the City's odor control locations.

B.2.3.1.3 Pretreatment Program

The Bureau's Industrial Waste Management Division (IWMD) administers the City's Pretreatment Program (Program) approved by the EPA on June 30, 1983. IWMD has worked to protect local receiving waters (rivers, oceans, and groundwater) and the quality of wastewater products that are recycled (recycled water and biosolids) by regulating industrial wastewater discharges to the City's sewer system and implementing source control and pollution prevention programs. These activities are conducted in accordance with the Los Angeles Municipal Code (LAMC) Section 64.30 Industrial Waste Control Ordinance and federal pretreatment regulations pursuant to 40 CFR 403 and the Clean Water Act (CWA).

Figure B.5
Odor Control Locations
 One Water LA 2040 Plan



-  ATF
 -  Carbon Scrubber
 -  WRP
 -  Outfall
 -  Primary Sewer
- Chemical Treatment**
-  Caustic Soda
 -  Magnesium Hydroxide
- Sewersheds**
-  Various Colors

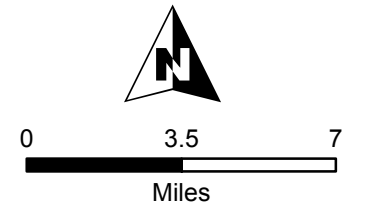
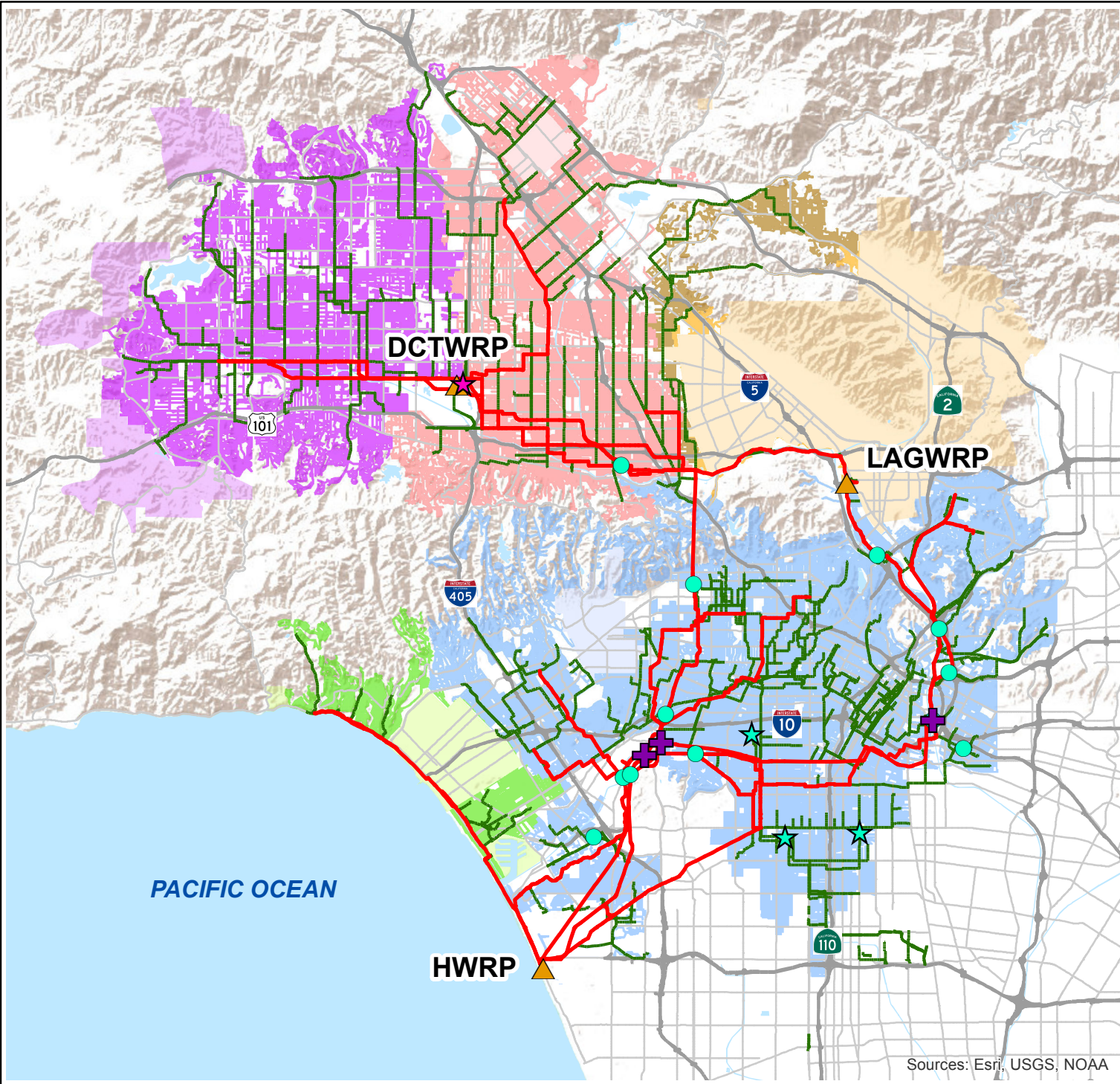

Sources: Esri, USGS, NOAA

The Program's success can be attributed to a thorough permitting process with proper application of pretreatment requirements, intensive and extensive field presence by the inspection staff, progressive enforcement actions for all violations, and aggressive public outreach and pollution prevention activities. The Program's overall goals include:

- protecting the water reclamation plants process operations from interference with and pass through of harmful pollutants to the environment;
- protecting the sewer collection system, protecting the life, health, and safety of operating and maintenance personnel;
- ensuring the health, safety, and welfare of the public;
- providing the opportunity for beneficial reuse of biosolids; and
- providing the opportunity for water reclamation.

The first step towards regulating an industrial user (IU) is the issuance of an Industrial Wastewater Permit (Permit). The Permit contains the pretreatment standards and local limits, monitoring and reporting requirements, and special and general conditions. Proper categorization and establishment of the Permit conditions and requirements involves an audit of the facility operations and wastewater generating processes. For the 2016 calendar year, there were a total of 18,710 IUs regulated which consist of 211 Significant Industrial Users, 6,218 Local Industrial Users, 10,546 Food Service Establishments, 1,719 Dental Offices and Clinics, and 29 Septage Haulers.

Program staff guide IUs into compliance through progressive administrative enforcement actions established in the Enforcement Response Plan (ERP). Since the implementation of the ERP, the percent compliance rate has increased from a low 56 percent in 1990 to a current average 93 percent in 2016.

The Program includes conducting inspections and monitoring to ensure that industries are in compliance with LAMC 64.30 Industrial Waste Control Ordinance as well as each IU's individual permit requirements. Surveillance monitoring is conducted within the sewer collection system to identify illegal discharges and to respond to water reclamation plant upsets or interference. IUs are also required to perform self-monitoring as part of their permit requirements.

A business that discharges industrial wastewater into the City sewer system may be classified as either a Significant Industrial User (SIU) or a Local Industrial User (LIU). A business classified as a SIU must monitor, report, and comply with federal pretreatment standards which require the installation of best available technology to remove harmful pollutants generated from their operations. A business is classified as a SIU if the operations are subject to national categorical regulations, or there is a discharge of an average of 25,000 gallons or more per day of process wastewater, or there is a discharge of wastewater that has a reasonable potential to impact the operation of the

POTW. Whereas, the business classified as a LIU is subject only to local limits and less stringent pretreatment standards since the discharge of process wastewater containing pollutants is not significant.

B.2.3.1.3.1 Fats, Oils, and Grease (FOG) Control

FOG accumulates in the sewer lines and restricts flow, causing blockages that can potentially result in an overflow of sanitary wastewater out of the sewer system. The FOG also interferes with the operation of sewage pumping stations resulting in negative impacts in operations and maintenance. Following an extensive outreach to and in partnership with the over 10,000 food service establishments (FSEs) in Los Angeles, the City developed a three-pronged approach to FOG Control, including:

1. Source Control
2. Sewer Cleaning
3. Community Outreach and Education

Recognizing the adverse impact of FOG-related SSOs on public health and the environment, the City Council enacted a FOG Control Ordinance (Number 174,047) effective August 5, 2001. This Ordinance amended the Los Angeles Municipal Code Section 64.30 and the Board of Public Works' (Board) Rules and Regulations Governing Disposal of Industrial Wastewater into the Publicly Owned Treatment Works (POTW) of the City of Los Angeles (Rules and Regulations). The Ordinance provides the City with the authority to regulate the discharge of FOG into the sewer system and mandates the implementation of FOG Best Management Practices (BMPs).

FOG BMPs are a series of activities that effectively manage and control disposal of FOG generated waste from the operation of FSEs. For the FOG Control Program, BMPs are "clean kitchen" practices. BMPs focus on:

- Good housekeeping measures
- Operation management techniques
- Spill control
- Proper waste disposal
- Recycling

FSEs are required to obtain an Industrial Wastewater Permit and comply with the FOG requirements covered under the Industrial Waste Control Ordinance and the Board of Public Works' Rules and Regulations. The FOG Control Program requirement includes, but is not limited to:

- All food service establishments will be required to use BMPs to reduce the grease discharged to the sewer system.
 - Collecting waste cooking oil and storing in drums or barrels for recycling

- Disposing food waste directly into trash/garbage can
- Using absorbent materials to clean up spills prior to mopping the floors
- The use of garbage grinders in food service establishments is prohibited, unless specifically allowed.
- Any FSE that is known to cause grease-related sewage spills or fails to implement BMPs will be required to install a grease interceptor or a grease trap.
- All new construction of FSEs must include the installation of a grease interceptor.
- All new FSEs that underwent a Change of Use is required to include the installation of a grease interceptor.
- All existing FSEs planning a remodel valued at \$100,000.00 or more will be required to include the installation of a grease interceptor.
- Exemptions, conditional waivers, or variances will be available to the FSEs that do not generate grease or have very limited space and inadequate slope in their property such that installation of a grease interceptor is unfeasible.

The success of the FOG Control Program, in conjunction with the City's aggressive sewer cleaning and maintenance program, has reduced the overall FOG-related sewer overflows by 85 percent.

B.2.3.1.4 Root Control

In addition to the City's routine maintenance activities including mechanical root removal, the City started a program in 2002 to control the growth of roots in sewers by the use of environmentally safe chemicals. The effectiveness of chemical root control treatment is carefully monitored and the frequency of treatment and application rates adjusted as required to eliminate blockages caused by roots. In 2006, the City started a community outreach and education program to control roots in private sewer laterals located in root hot spots. A root control pamphlet (http://www.lasewers.org/sewers_shared/pdf/tree_roots_brochure.pdf) is mailed to properties in root hot spots where there is significant tree roots intrusion into the mainline sewers, requiring frequent root removal and chemical treatment to avoid sewer blockages. On average, the City performs root removal and chemical treatment on 400 miles of sewers per year.

B.2.4 Sewer Capacity Availability Review

The Sewer Capacity Availability Review (SCAR) program is designed to evaluate the local sewer flow levels to determine the current flow condition and identify any available capacity that could exist. They are used to evaluate the cumulative impact of future proposed additional flows to the sewer system and to help guide the planning process for any future sewer improvement projects needed to provide future capacity as the City grows and develops. From 2012 through 2016, the City completed an average of 332 SCARs per year.

The total number of SCARs processed in 2016 was 537 SCARs. SCARs are typically requested for the following types of projects:

4. New construction or modification to an existing structure, if it will generate additional flow higher than approved by the Sewer Facilities Charge.
5. Industrial Waste Users
6. Construction dewatering efforts associated with groundwater remediation projects and/or construction projects.

SCAR assesses sewer capacity availability for a proposed property development as part of the approval process and provides the appropriate actions that are to be taken based on the results of such assessment. A SCAR is required whenever a sewer availability determination and approval is requested from the Bureau of Engineering as part of a building permit approval process for new sewer connections or modifications involving residential, commercial and industrial developments, an environmental impact documentation process, report preparation for the Tract and Parcel Maps for proposed developments and public and private construction groundwater dewatering activities.

The SCAR program enables the City to track sewer flow discharge requested from all new construction developments and consequently plan for any necessary capacity improvements.

HYPERION WATER RECLAMATION PLANT CONCEPT OPTIONS

This appendix provides information pertaining to the implementation of those concept options developed specifically for HWRP. Chapter 4 – Hyperion Water Reclamation Plant includes an overview of the approach to the development and prioritization of concept options. Additionally, the preferred, or selected, approach to optimize reuse from this facility is repeated.

C.1 BACKGROUND

The preliminary list of concept options that support a locally sourced water supply was developed through workshops that solicited ideas and input from a workgroup as well as community stakeholders. This workgroup included contributors from an array of communities, LASAN, LADWP, other City Bureaus and Departments and select technical advisors. These ideas resulted in the development of concept options within the 2040 planning horizon. Concept options represent new concepts that have not been previously evaluated by the City.

With this methodology, a list of 27 concept options was developed for the entire system. Of these 27 concept options, eight concept options were related to HWRP. One concept option was eliminated due to a fatal flaw. Determination of Hyperion's future system needs were based on previous master plans, planning documents, discussions with City staff, and brainstorming sessions. The concept options are preliminary in nature and are not a commitment to level or quantity of treatment.

C.2 HWRP CONCEPT OPTIONS

Table C.1 lists the concept options associated with HWRP, including the normal year estimated yield and associated capital costs. As shown in Table C.1, the concept options for HWRP involved one of the three reuse strategies:

- Potable reuse with groundwater augmentation - Projects that would spread (infiltrate) or directly inject recycled water into a groundwater basin that could be used as potable water after extraction and further treatment.
- Potable reuse with raw water augmentation - Projects that would deliver advanced treated recycled water (purified water) to a conventional water treatment plant before distributing into a potable water system.

- Potable reuse with treated water augmentation - Projects that would deliver advanced treated recycled water (purified water) directly to a potable water system.

| Table C.1 HWRP Concept Options Wastewater Facilities Plan One Water LA 2040 Plan | | | | | |
|----------------------------------------------------------------------------------------------------------------------------------------------------------------------------------------------------------------------|-------------------------------------------------------|----------------------------------------------------|--------------------------------------|-----------------------------------------|--------------------------|
| Concept Option # | Title | Strategy | Estimated Yield (Normal Year) | Capital Cost (\$M)⁽¹⁾ | Unit Cost (\$/AF) |
| 10 | Hyperion WRP to West Coast Basin Injection Wells | Potable Reuse with Groundwater Augmentation | 20,000 AFY (17 mgd) | \$900 | \$3,200 |
| 11 | Hyperion WRP to Central Basin Injection Wells | Potable Reuse with Groundwater Augmentation | 75,000 AFY (70 mgd) | \$3,300 | \$2,700 |
| 13 | MBR at Hyperion WRP to Regional System | Potable Reuse with Groundwater Augmentation | 95,000 AFY (85 mgd) | \$900 | \$1,500 |
| 14 | Hyperion WRP to San Fernando Basin Injection Wells | Potable Reuse with Groundwater Augmentation | 20,000 AFY (18 mgd) | \$680 | \$2,400 |
| 18 | Hyperion WRP to LADWP Distribution System | Potable Reuse with Treated Water Augmentation | 95,000 AFY (85 mgd) | \$2,800 | \$2,100 |
| 19 | Hyperion WRP to Headworks Reservoir | Potable Reuse with Treated Water Augmentation | 95,000 AFY (85 mgd) | \$3,200 | \$2,400 |
| 20 | Hyperion WRP to Los Angeles Aqueduct Filtration Plant | Potable Reuse with Raw Water Augmentation | 95,000 AFY (85 mgd) | \$3,600 | \$2,600 |
| Note: | | | | | |
| (1) Total Concept Option cost includes a variety of project components including treatment facilities, conveyance, and injection and extraction facilities. Not all costs pertain to the Wastewater Facilities Plan. | | | | | |
| (2) Bold indicates a Priority A Concept Option | | | | | |
| (3) Concept Option #12 was determined to have a fatal flaw resulting from 1) a lack of capacity in the existing Rio Hondo Spreading Grounds and 2) a lack of vacant land to construct new spreading basins. | | | | | |

While there are differences between the options in terms of capacity, delivery location and ultimate use, all require similar levels of advanced treatment.

C.3 SUMMARY OF THE PREFERRED APPROACH

As part of the WWFP development, each of the concept options listed above was reviewed to identify improvements that would need to be implemented at the plant as well as system changes to convey that product water. This analysis included preliminary sizing of treatment process modifications, location of the processes, and preliminary cost estimates. Based on the overall concept score, cost estimates, and portfolio evaluation results, the concept options were prioritized. The concept options for HWRP were prioritized as follows:

- Priority A: Concept Option #13 - Potable Reuse from MBR at HWRP to Regional System
- Priority B: Concept Option #18 - Potable Reuse with treated water augmentation from HWRP to the City's distribution system
- Priority C-1: Concept Option #11 - Potable Reuse with groundwater augmentation from HWRP to Central Basin with injection wells
- Priority C-2: Concept Option #10 - Potable Reuse with groundwater augmentation from HWRP to West Coast Basin with injection wells

It can be concluded that all concept options involve the installation of additional treatment facilities at HWRP to deliver either MBR quality or advanced treated water for the various potable reuse project configurations. In addition, all selected concept options have the same capacity of 95,000 afy. This capacity is based on the estimated available flow from HWRP for future water reuse projects after consideration of existing projects, already planned projects, estimated future flow increases, and treatment losses. For concept options #10 and #11, the total available flow of 95,000 afy was proportionally allocated between the Central and West Coast Basins based on the estimated storage capacity of these basins.

As shown on Figure C.1, the most critical trigger of highest ranked potable reuse opportunity Concept Option #13 (MBR at HWRP to Regional System) is establishing an institutional agreement with a regional project partner, such as MWD, LACSD, or WBMWD. In case such an agreement does not materialize, the second highest ranked potable reuse opportunity is Concept Option #18 (Treated Water Augmentation from HWRP to Distribution System). The most critical trigger for this concept option is the adoption of potable reuse with treated water augmentation regulations that would allow this type of water reuse practice. In case the potable regulations are not accepted within a desired timeframe or if the City prefers a more conventional form of water reuse, the third best potable reuse option from HWRP are Concept Options #10 and #11, consisting of groundwater augmentation in the West Coast and Central Basin, respectively. These two concept

options will require an institutional agreement with WRD, who acts as the water master of these two groundwater basins. In case such an agreement does not materialize and potable reuse regulation are not approved, it is recommended to postpone the implementation of a large scale potable reuse project from HWRP, which is indicated as "No Change" on Figure C.1.

It should be noted that there were four (4) other concept options developed for HWRP that were not included in the implementation strategy because the options were not considered viable at this time. The other potable reuse opportunities from HWRP are:

- Concept Option #14: Potable Reuse with groundwater augmentation from HWRP to San Fernando Basin with injection wells
- Concept Option #18: Potable Reuse with treated water augmentation from HWRP to the LADWP's distribution system
- Concept Option #19: Potable Reuse with treated water augmentation from HWRP to the LADWP's distribution system via Headworks Reservoir
- Concept Option #20: Potable Reuse with raw water augmentation from HWRP to the Los Angeles Aqueduct Filtration Plant (LAAFP)

However, triggers, underlying conditions, and assumptions made for the development of these concept options are likely to change in the future. It is therefore recommended that City staff closely monitor all triggers and other circumstances that may impact the viability and prioritization of all concept options developed for HWRP. Future changed conditions may not only change the prioritization of the concept options included as Priority A, B, and C, but also impact the viability of the four other potable reuse options from HWRP that are not included in the implementation strategy.

C.4 CONCEPT OPTION IMPLEMENTATION

Each of the seven HWRP concept options is discussed in the following subsection. Included are:

- General narrative description of concept option
- Concept schematic
- System requirements for improvement needed to implement
- Location map depicting HWRP and end use
- Outline of potential upgrades to HWRP to accommodate option
- Site plan of HWRP highlighting areas impacted

Hyperion Water Reclamation Plant

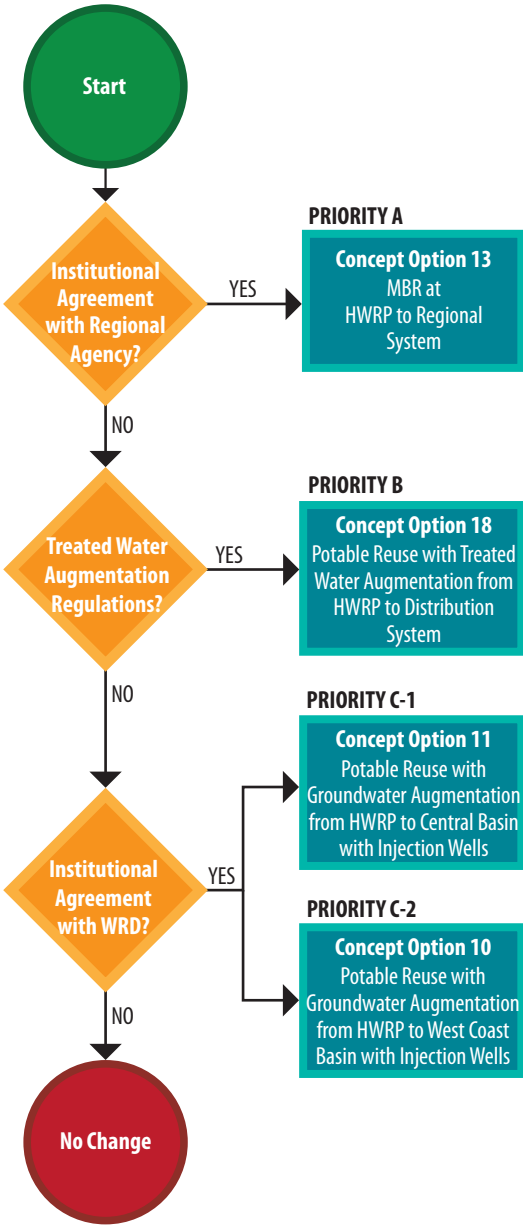

LEGEND & ACRONYMS

- ◆ Trigger
- Concept Option
- Flow Management Option

| | |
|--------|-----------------------------------------------------|
| DCTWRP | Donald C. Tillman Water Reclamation Plant |
| GWR | Groundwater Replenishment Project |
| HWRP | Hyperion Water Reclamation Plant |
| LAGWRP | LA-Glendale Water Reclamation Plant |
| RWQCB | Regional Water Quality Control Board |
| TIWRP | Terminal Island Water Reclamation Plant |
| WRD | Water Replenishment District of Southern California |

Disclaimer: At each trigger (decision point), evaluate all triggers and concept option priorities to consider changed circumstances in the future.

Figure C.1
Trigger-Based Implementation Strategy for HWRP
One Water LA 2040 Plan
Summary Report

C.4.1 Concept Option #10 (HWRP to West Coast Basin)

The HWRP to West Coast Basin Injection Wells recharge concept would consist of newly constructed advanced treatment facilities at HWRP combined with recharge and recovery in the West Coast Basin via new injection and production wells.

The estimated timeline for the HWRP to West Coast Basin Injection Wells concept would be 2030-2040 and this concept could yield 20,000 AFY (17 mgd) of potable water during for normal years, wet years, and dry years. Figure C.2 shows the overall process concept flow schematic for this option, indicating that after being advanced treat, treated water would be pumped to injection wells and eventually be extracted, treated, and served through the LADWP potable water distribution system.

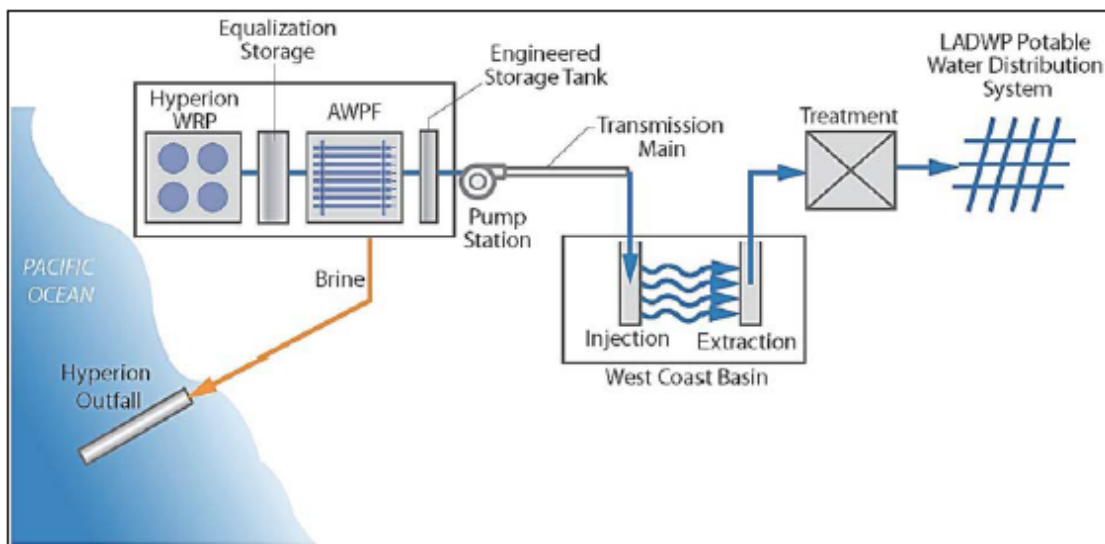

Figure C.2 Process Flow Schematic Concept Option #10 (HWRP to West Coast Basin Injection Wells)

C.4.1.1 System Upgrades

System upgrades may be required for the implementation of the HWRP to West Coast Basin Injection Wells concept option. These system upgrades could consist of conveyance and lateral pipelines, injection and extraction wells and groundwater treatment facilities. Details of the upgrades are summarized in Table C.2. System upgrades and new facilities would be planned in coordination with identified agencies necessary for project implementation.

| Table C.2 System Upgrades for Concept Option #10 (HWRP to West Coast Basin Injection Wells⁽¹⁾) Wastewater Facilities Plan One Water LA 2040 Plan | |
|----------------------------------------------------------------------------------------------------------------------------------------------------------------------------|-------------------------------------------------------------------------|
| Description | Quantity |
| Estimated Yield (Normal/Wet/Dry Year) | 20,000 AFY (17 mgd) ⁽²⁾ |
| Conveyance Pipeline | 5 miles of 42-inch diameter |
| Pipeline laterals | 15 miles of 12 and 16-inch diameter |
| Wells | 17 medium depth injection wells and 17 medium depth extraction wells |
| Groundwater Treatment | 25 mgd |
| Notes: (1) Key assumptions in sizing of the components are summarized in Section 2.5 (2) Estimated Yields are based on Table 2, TM 5.2 | |

The system upgrades are conceptually shown in the system upgrade shown on Figure C.3.

C.4.1.2 HWRP Upgrades

Facility upgrades at HWRP may be required for the implementation of the HWRP to West Coast Basin Injection Wells concept option. These system upgrades could consist of AWT facilities, primary influent equalization and product water pump station facilities. Preliminary details of the upgrades are summarized in Table C.3. The new AWT facilities would treat the recycled water to match DDW's potable reuse with groundwater augmentation requirements at the time of project implementation and for the purposes of the WWFP have been assumed to consist of MF, RO, and UV/AOP. The equalization facilities have potential to impact plant operations due to their location within HWRP. Potential options for the location of the equalization include Primary Battery D, underneath the parking lot, abandoned digesters, or on the site of the emergency overflow basin. The location of primary influent equalization would need to be evaluated and determined during detailed design should this concept option be selected for implementation. The new product water pump station could be located within the RO-UV/AOP building.

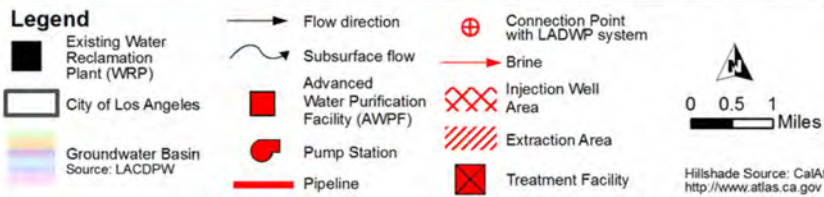
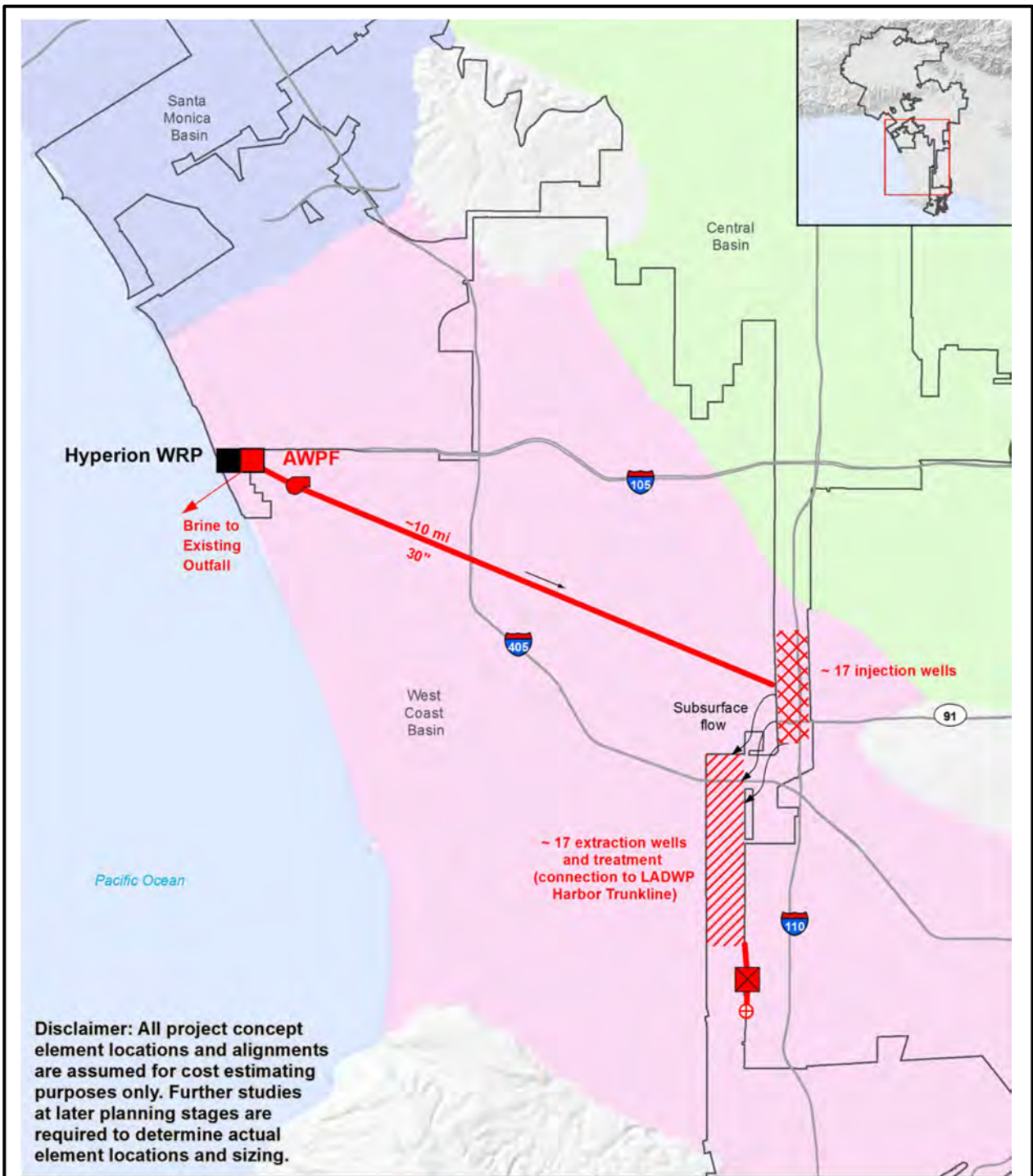

Figure C.3
System Upgrades for Concept Option #10
(HRP to West Coast Basin Injection Wells)
 One Water LA 2040 Plan

| Table C.3 Potential Upgrades for Concept Option #10 (HWRP to West Coast Basin Injection Wells) Wastewater Facilities Plan One Water LA 2040 Plan | | |
|-----------------------------------------------------------------------------------------------------------------------------------------------------------------|-----------------|--------------|
| Description | Quantity | Units |
| Primary Effluent (Feedwater) | 21 | mgd |
| Wastewater Equalization | 5.0 | MG |
| Wastewater Equalization Footprint | 15,000 | sq ft |
| Wastewater Equalization Hydraulic Retention Time | 5.70 | hr. |
| Bioreactors to Retrofit | 21 | mgd |
| Bioreactor Trains to Retrofit | 2 | quantity |
| Membrane Separation Footprint | 12,000 | sq ft |
| Membrane Permeate Flow | 20 | mgd |
| WAS Flow | 1 | mgd |
| RO / UV/AOP Permeate Flow | 17 | mgd |
| RO / UV/AOP Footprint | 17,000 | sq ft |
| Brine Flow | 3 | mgd |
| Chemical Facility Footprint | 9,000 | sq ft |
| Pump Station | 3,500 | hp |
| Pump Station Footprint | 3,000 | sq ft |
| Secondary Clarifiers Demolition | 41,000 | sq ft |
| Clarifier Modules to Replace (4 per Module) | 1 | quantity |
| Assumptions: | | |
| (1) Wastewater Equalization and Product Water Equalization Tanks are assumed to be 45 ft deep | | |
| (2) Primary influent is assumed at 5% solids | | |
| (3) RO recovery is assumed at 85% | | |
| (4) Footprint for MBR/RO/AOP Facilities is based upon Hyperion Reuse Feasibility Study (MWH, May 2016) | | |
| (5) Footprint for Pump Station is based upon Hyperion West Basin Secondary Effluent Pump Station (Bid Documents, April 2017) | | |

Figure C.4 depicts potential AWPf locations at HWRP.

C.4.2 Concept Option #11 (HWRP to Central Basin Injection Wells)

The HWRP to Central Basin Injection Wells concept option would consist of newly constructed advanced treatment facilities at HWRP, combined with recharge and recovery in the Central Basin via new injection and production wells. The concept could produce up to 75,000 AFY (70 mgd) of water for recharge and reuse in the Central Basin during normal years, wet years, and dry years.

Document Path: P:\WorkStation\City_LA_BOS_MXDs\Task7_TMGI\HWRP_PPEB_Ph1_20170918.mxd



- Potential Primary Equalization Basin
- Fine Screen
- Hyperion Recycled Water Pump Station
- RO-UV/AOP/Chemicals
- MBR

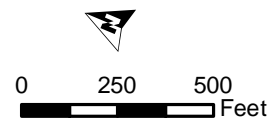

Figure C.4
Potential Upgrades for Concept Option #10
 (HWRP to West Coast Basin Injection Wells)
 One Water LA 2040 Plan



The expected timeline for the Concept Option #11 is 2030-2040. A similar concept option was evaluated using the spreading grounds in Central Basin, but was determined to have a fatal flaw in that the spreading basins have no additional capacity. The concept option using spreading basins in Central Basin was not developed further. Figure C.5 shows a schematic of this option. Advanced treated water from HWRP could be pumped to the Central Basin Injection wells, and after some time, extracted, treated, and served via LADWP's potable water distribution system.

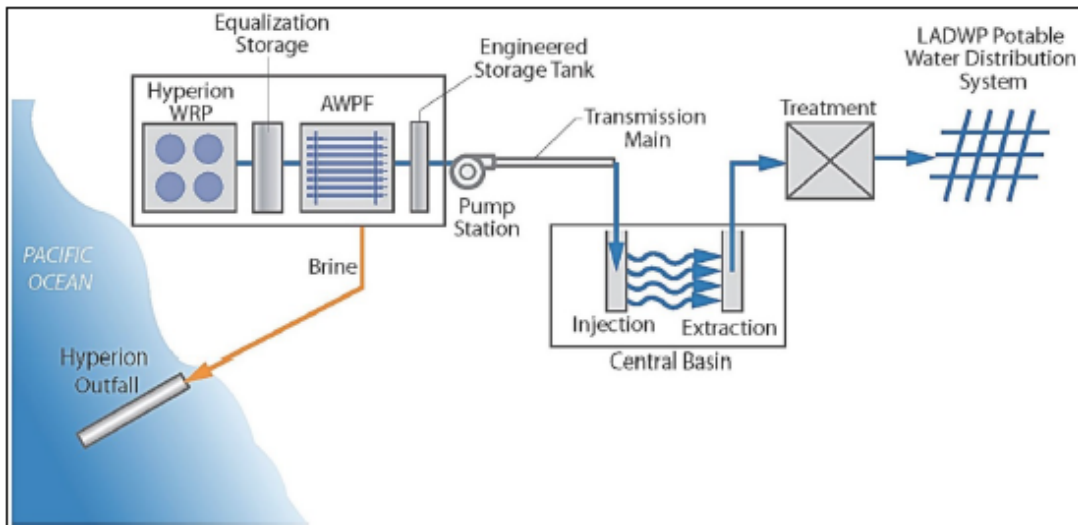
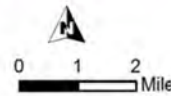
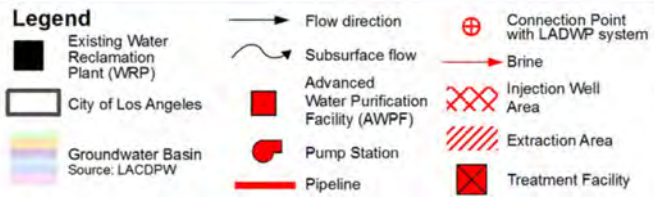
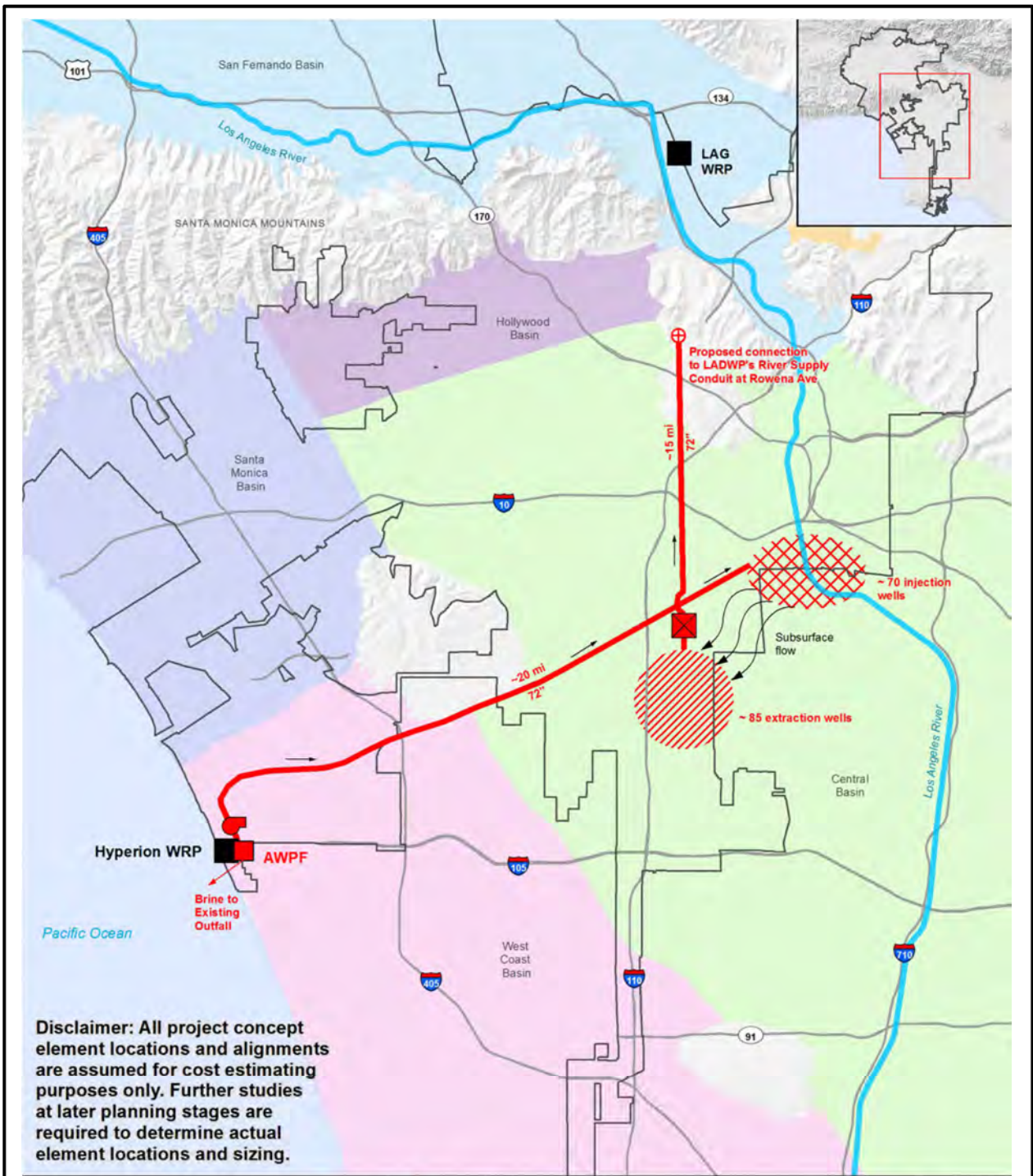

Figure C.5 Process Flow Schematic for Concept Option #11 (HWRP to CB Injection Wells)

C.4.2.1 System Upgrades

System upgrades may be needed and are summarized in Table C.4 on shown on Figure C.6.

| Table C.4 System Upgrades for Concept Option #11 (HWRP to CB Injection Wells) Wastewater Facilities Plan One Water LA 2040 Plan | |
|------------------------------------------------------------------------------------------------------------------------------------------------------------|----------------------------------------------------------------------|
| Description | Quantity |
| Estimated Yield (Normal/Wet/Dry Year) | 75,000 AFY (70 mgd) ⁽²⁾ |
| Conveyance Pipeline | 20 miles of 72-inch diameter |
| Pipeline laterals to injection site | 50 miles of 12 and 16-inch diameter |
| Pipeline laterals to LADWP Distribution | 10 miles of 72-inch diameter |
| Wells | 70 medium depth injection wells and 70 medium depth extraction wells |
| Groundwater Treatment | 100 mgd |
| Notes: (1) Estimated Yields are based on TM 5.2 | |



Hillshade Source: CalAtlas
<http://www.atlas.ca.gov>

Figure C.6
System Upgrades for Concept Option #11 (HWRP to Central Basin Injection Wells)
 One Water LA 2040 Plan

C.4.2.2 HWRP Upgrades

Facility upgrades at HWRP may also be required for the implementation of the HWRP to Central Basin Injection Wells Concept Option. These system upgrades could consists of AWT facilities, primary influent equalization and product water pump station facilities. Preliminary details of the upgrades are summarized in Table C.5. The new AWT facilities may treat the recycled water to match DDW's potable reuse with groundwater augmentation requirements. The equalization facilities have potential to impact plant operations due to their location within HWRP. Potential options for the location and depth will be confirmed during detailed design should this project be selected for implementation. The new product water pump station may be located within the RO-UV/AOP building. Figure C.7 depicts potential AWPf locations at HWRP.

| Table C.5 Potential Upgrades for Concept Option #11 (HWRP to CB Injection Wells) Wastewater Facilities Plan One Water LA 2040 Plan | | |
|---------------------------------------------------------------------------------------------------------------------------------------------------|-----------------|--------------|
| Description | Quantity | Units |
| Primary Effluent (Feedwater) | 87 | mgd |
| Wastewater Equalization | 20.0 | MG |
| Wastewater Equalization Footprint | 60,000 | sq ft |
| Wastewater Equalization Hydraulic Retention Time | 5.54 | hr. |
| Bioreactors to Retrofit | 87 | mgd |
| Bioreactor Trains to Retrofit | 8 | quantity |
| Membrane Separation Footprint | 46,000 | sq ft |
| Membrane Permeate Flow | 82 | mgd |
| WAS Flow | 4 | mgd |
| RO / UV/AOP Permeate Flow | 70 | mgd |
| RO / UV/AOP Footprint | 70,000 | sq ft |
| Brine Flow | 12 | mgd |
| Chemical Facility Footprint | 35,000 | sq ft |
| Pump Station ⁽¹⁾ | 13,000 | hp |
| Pump Station Footprint | 10,000 | sq ft |
| Secondary Clarifiers Demolition | 161,000 | sq ft |
| Clarifier Modules to Replace (4 per Module) | 2 | quantity |
| Assumptions: | | |
| (1) HP calculations assumed an elevation of 700 ft and an LF of 60,000 | | |
| (2) Wastewater Equalization and Product Water Equalization Tanks are assumed to be 45 ft deep | | |
| (3) Primary influent is assumed at 5% solids | | |
| (4) RO recovery is assumed at 85% | | |
| (5) Footprint for Facilities is based upon Hyperion Reuse Feasibility Study (MWH, May 2016) | | |
| (6) Footprint for Pump Station is based upon Hyperion West Basin Secondary Effluent Pump Station (Bid Documents, April 2017) | | |



- Potential Primary Equalization Basin
- Fine Screen
- Hyperion Recycled Water Pump Station
- RO-UV/AOP/Chemicals
- MBR

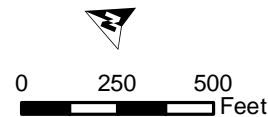

Figure C.7
Potential Upgrades for Concept Option #11
(HWRP to Central Basin Injection Wells)
 One Water LA 2040 Plan

C.4.3 Concept Option #13 (MBR at HWRP to Regional System)

HWRP has the potential capacity to supply 78,000 to 95,000 AFY (70 - 85 mgd) of MBR effluent for distribution to other regional systems (such as Santa Monica, Beverly Hills, etc.). If MBR treatment is implemented at HWRP, the amount of flow delivered to other regional systems is dependent upon the amount of flow that HWRP dedicates to projects that take precedent over distribution to other regional systems. Depending on the regional system, this potential concept may include an MBR facility a pump station, conveyance, recovery via extraction wells, connection to a potable distribution system, and new production facilities to recover and convey recharged water to the other regional system. Figure C.8 shows the MBR effluent conveyed to Regional Facility and the brine from MBR treatment discharged via the Hyperion outfall.

The estimated timeline for the MBR at HWRP to Regional System concept is 2030-2040 and the concept is estimated to yield 95,000 AFY (85 mgd) of potable water during for normal years, wet years, and dry years.

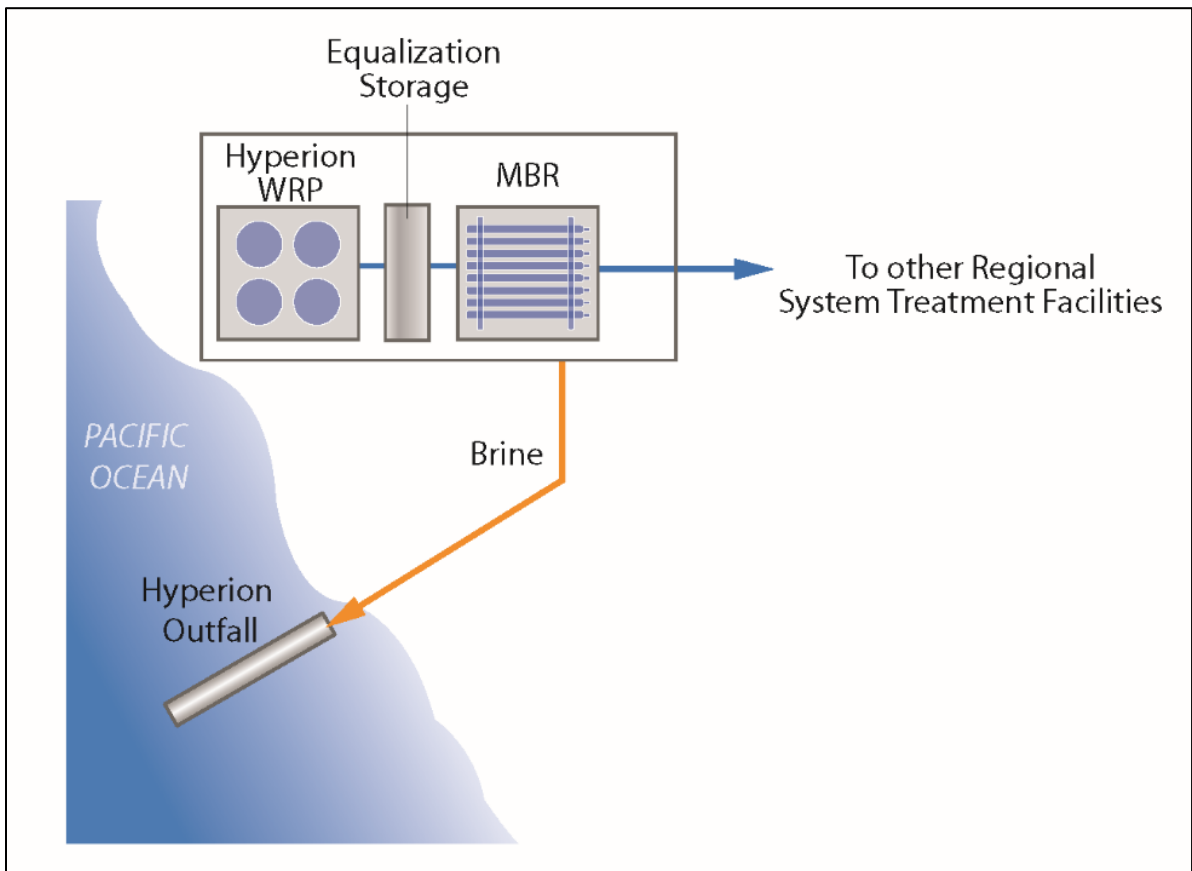

Figure C.8 Process Flow Schematic for Concept Option #13 (MBR at HWRP to Regional System)

C.4.3.1 System Upgrades

System upgrades may be needed for the implementation of the MBR at HWRP to Regional System concept. This concept could require new recharge and production wells, new MBR facilities, and a large amount of conveyance. Details of this concept option, including system infrastructure requirements, would need to be developed should this concept option be chosen to be implemented.

C.4.3.2 HWRP Upgrades

Facility upgrades at HWRP may be needed for the implementation of the MBR at HWRP to Regional System concept option. In particular, facility upgrades could include 25 MG of equalization and 85 mgd of MBR (89 mgd feedwater). The sizing of the equalization facilities may require a deeper partially buried tank. Potential design criteria for the HWRP upgrades is summarized in Table C.7. Figure C.9 depicts potential locations at HWRP.

| Table C.7 Potential Upgrades Concept Option #13 (MBR at HWRP to Regional System) Wastewater Facilities Plan One Water LA 2040 Plan | | |
|---------------------------------------------------------------------------------------------------------------------------------------------------|-----------------|--------------|
| Description | Quantity | Units |
| Primary Effluent (Feedwater) | 89 | mgd |
| Wastewater Equalization | 25.0 | MG |
| Wastewater Equalization Footprint | 75,000 | sq ft |
| Wastewater Equalization Hydraulic Retention Time | 6.71 | hr |
| Bioreactors to Retrofit | 85 | mgd |
| Bioreactor Trains to Retrofit | 8 | quantity |
| Membrane Separation Footprint | 45,000 | sq ft |
| Membrane Permeate Flow | 85 | mgd |
| WAS Flow | 4 | mgd |
| Pump Station | 13,000 | hp |
| Pump Station Footprint | 10,000 | sq ft |
| Secondary Clarifiers Demolition | 55,000 | sq ft |
| Clarifier Modules to Replace (4 per Module) | 1 | quantity |
| <u>Assumptions:</u> | | |
| (1) Wastewater Equalization and Product Water Equalization Tanks are assumed to be 45 ft deep | | |
| (2) Primary influent is assumed at 5% solids | | |
| (3) Footprint for MBR Facilities is based upon Hyperion Reuse Feasibility Study (MWH, May 2016) | | |
| (4) Footprint for Pump Station is based upon Hyperion West Basin Secondary Effluent Pump Station (Bid Documents, April 2017) | | |

Document Path: \\usinv1s01\GIS\GIS_Jobs\City_LA_BOS_MXD\Task7_TM\G\HWRP_PPEB_Metropolitan_20170914.mxd



- Proposed Facility
- Fine Screen
- Hyperion Recycled Water Pump Station
- MBR

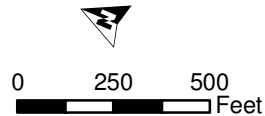

Figure C.9
Potential Upgrades
for Concept Option #13
(MBR at HWRP to Regional
System)
 One Water LA 2040 Plan

C.4.4 Concept Option #14 (HWRP to San Fernando Basin Injection Wells)

One concept option is to potentially treat a portion of the water with an AWPf located at the HWRP, then pump the water via a new pipeline over the Santa Monica Mountains to the San Fernando Valley. In the San Fernando Valley, the water would be stored in the San Fernando Valley groundwater basin, through injection wells. The brine from the AWPf would be discharged through the 5-mile outfall at HWRP. Surface spreading is not considered for this concept option as it was assumed that there will not be capacity for additional surface recharge after the Groundwater Replenishment Project with AWPf at DCTWRP is completed. The water could be stored in the groundwater basin until it is pumped using existing extraction wells.

The estimated timeline for the HWRP to San Fernando Basin Injection Wells concept is 2030-2040 and the concept is estimated to yield 20,000 AFY (18 mgd) of potable water during normal years, wet years, and dry years. Figure C.10 shows the overall concept flow schematic, with advanced treated water being conveyed over Santa Monica Mountains via Coldwater Canyon. The advanced treated water would then be directly injected into the San Fernando Basin, and after time, extracted using existing extraction wells, treated, and served through LADWP's potable water distribution system.

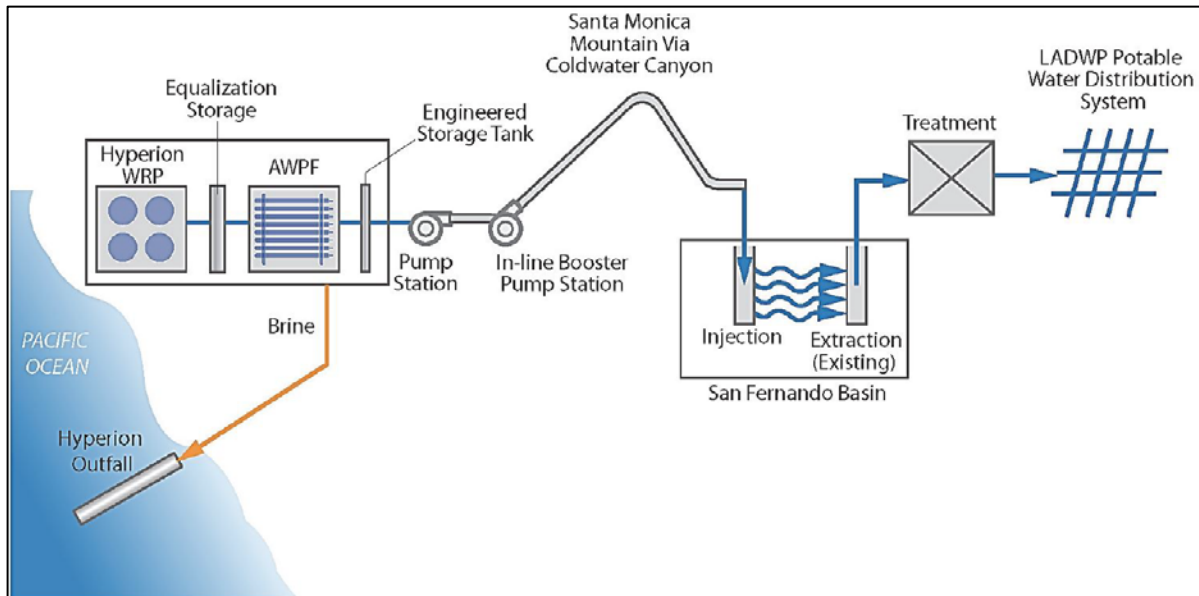

Figure C.10 Process Flow Schematic for Concept Option #14 (HWRP to SF Basin Injection Wells)

C.4.4.1 System Upgrades

System upgrades may be required for the implementation of the HWRP to San Fernando Basin Injection Wells concept option. These potential system upgrades are summarized in Table C.8 and depicted conceptually in Figure C.11.

| Table C.8 System Upgrades for Concept Option #14 (HWRP to SF Basin Injection Wells)⁽¹⁾ Wastewater Facilities Plan One Water LA 2040 Plan | |
|--------------------------------------------------------------------------------------------------------------------------------------------------------------------------------|------------------------------|
| Description | Quantity |
| Estimated Yield (Normal/Wet/Dry Year) | 20,000 AFY (18 mgd) |
| Transmission Pipeline | 30 miles of 36-inch diameter |
| Pipeline laterals | 3 miles of 12-inch diameter |
| Pump Station | One 4,000 hp |
| Wells | 7 injection wells |
| Groundwater Treatment | 27 mgd |
| Notes: | |
| (1) Key assumptions in sizing of the components and estimated yield are summarized in TM 5.2 | |

C.4.4.2 HWRP Upgrades

Facility upgrades at HWRP could be required for the implementation of the HWRP to San Fernando Basin Injection Wells concept. These system upgrades may consist of AWPf facilities, equalization and product water pump station facilities. Details of the upgrades are summarized in Table C.9. The new AWPf facilities may consist of MF, RO, and UV/AOP. The equalization facilities have potential to impact plant operations due to their location within HWRP. Options for the location of the equalization include Primary Battery D, underneath the parking lot, or on the site of the emergency overflow basin. The new product water pump station could be located within the RO-UV/AOP building. Figure C.12 depicts potential AWPf locations at HWRP.

| Table C.9 Potential Upgrades for Concept Option #14 (HWRP to SF Basin Injection Wells) Wastewater Facilities Plan One Water LA 2040 Plan | | |
|---------------------------------------------------------------------------------------------------------------------------------------------------------------------|-----------------|--------------|
| Description | Quantity | Units |
| Primary Effluent (Feedwater) | 22 | mgd |
| Wastewater Equalization | 5.0 | MG |
| Wastewater Equalization Footprint | 15,000 | sq ft |
| Wastewater Equalization Hydraulic Retention Time | 5.38 | hr |
| Bioreactors to Retrofit | 22 | mgd |
| Bioreactor Trains to Retrofit | 2 | quantity |
| Membrane Separation Footprint | 12,000 | sq ft |
| Membrane Permeate Flow | 21 | mgd |
| WAS Flow | 1 | mgd |
| RO / UV/AOP Permeate Flow | 18 | mgd |

| Table C.9 Potential Upgrades for Concept Option #14 (HWRP to SF Basin Injection Wells) Wastewater Facilities Plan One Water LA 2040 Plan | | |
|---------------------------------------------------------------------------------------------------------------------------------------------------------|-----------------|--------------|
| Description | Quantity | Units |
| RO / UV/AOP Footprint | 18,000 | sq ft |
| Brine Flow | 3 | mgd |
| Chemical Facility Footprint | 9,000 | sq ft |
| Secondary Clarifiers Demolition | 39,000 | sq ft |
| Clarifier Modules to Replace (4 per Module) | 1 | quantity |
| Product Water Storage | 2.0 | MG |
| Product Water Storage Footprint | 6,000 | sq ft |
| Product Water Storage Hydraulic Retention Time | 2.67 | hr |
| Pump Station | 3,000 | hp |
| Pump Station Footprint | 3,000 | sq ft |
| Reservoir and PS Area | 9,000 | sq ft |
| Assumptions: | | |
| (1) Wastewater Equalization and Product Water Equalization Tanks are assumed to be 45 ft deep | | |
| (2) Primary influent is assumed at 5% solids | | |
| (3) RO recovery is assumed at 85% | | |
| (4) Footprint for Facilities is based upon Hyperion Reuse Feasibility Study (MWH, May 2016) | | |
| (5) Footprint for Pump Station is based upon Hyperion West Basin Secondary Effluent Pump Station (Bid Documents, April 2017) | | |

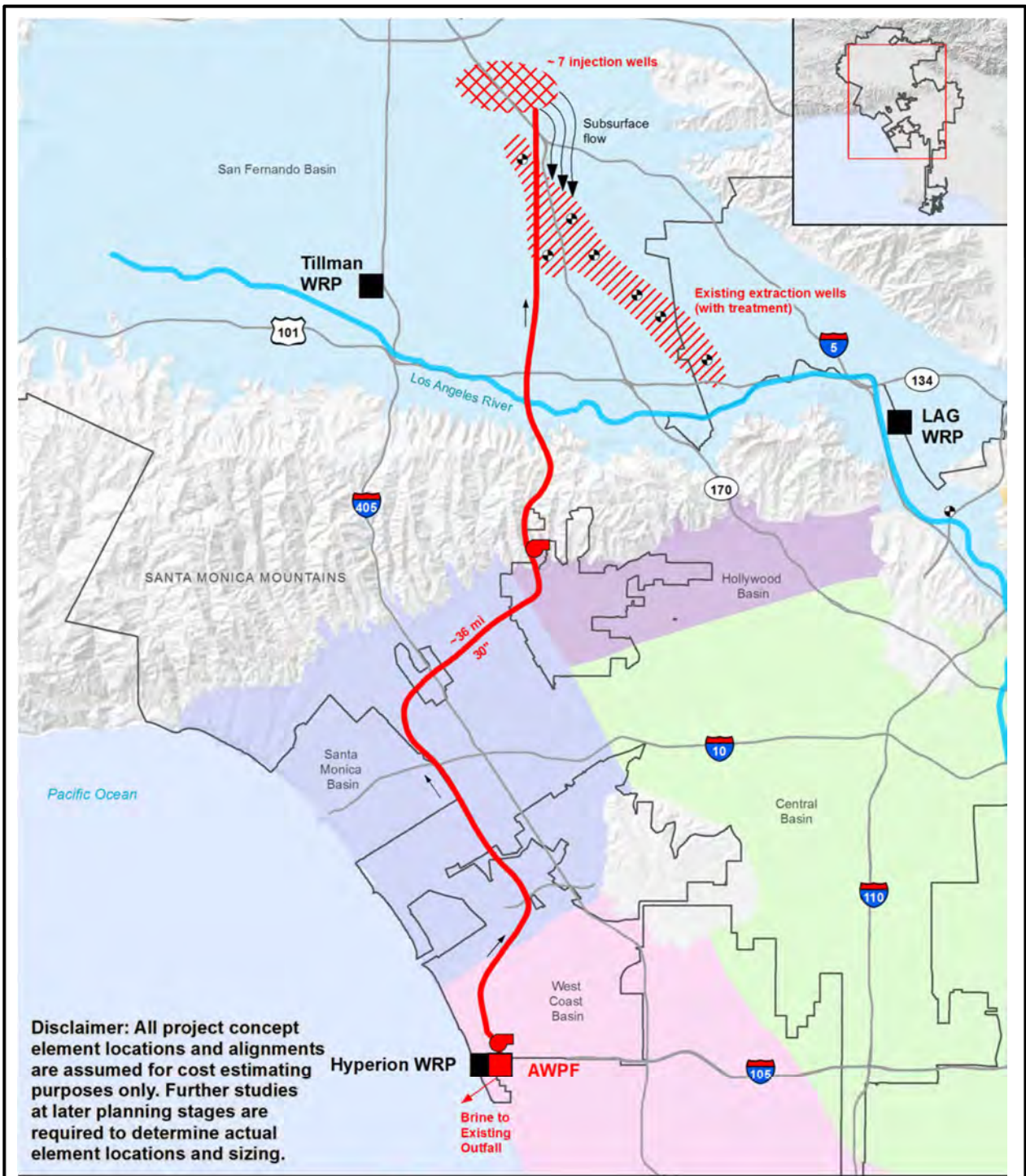

Figure C.11
System Upgrades for Concept Option #14 (HWRP to San Fernando Basin Injection Wells)
 One Water LA 2040 Plan

Document Path: P:_WorkStation\City_LA_BOS_MXDs\Task7_TMGI\HWRP_PPEB_Ph1_v2_20170914.mxd



- Potential Primary Equalization Basin
- Fine Screen
- Hyperion Recycled Water Pump Station
- RO-UV/AOP/Chemicals
- MBR
- Reservoir

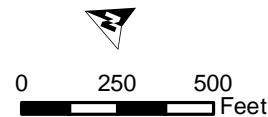

Figure C.12
Potential Upgrades for Concept Option #14
(HWRP to San Fernando Basin Injection Wells)
 One Water LA 2040 Plan

C.4.5 Concept Option #18 (HWRP to LADWP Distribution System)

A potential potable reuse with treated water augmentation option for HWRP could be to treat the water with an AWPf located at the HWRP and pump the water directly to the LADWP distribution system. It is anticipated that the AWPf would provide FAT and additional processes may be needed to comply with anticipated future potable reuse with treated water augmentation regulations. For the purposes of this WWFP the treatment train is assumed to be O₃/BAF, UF, RO, and UV/AOP. Brine would be discharged through the Hyperion 5-mile Outfall. Figure C.13 shows the schematic for this option, with storage tanks as an engineered buffer before distributing to the potable water system. The estimated timeline is 2030-2040 and the concept is estimated to yield 95,000 AFY (85 mgd) of potable water during normal years, wet years, and dry years.

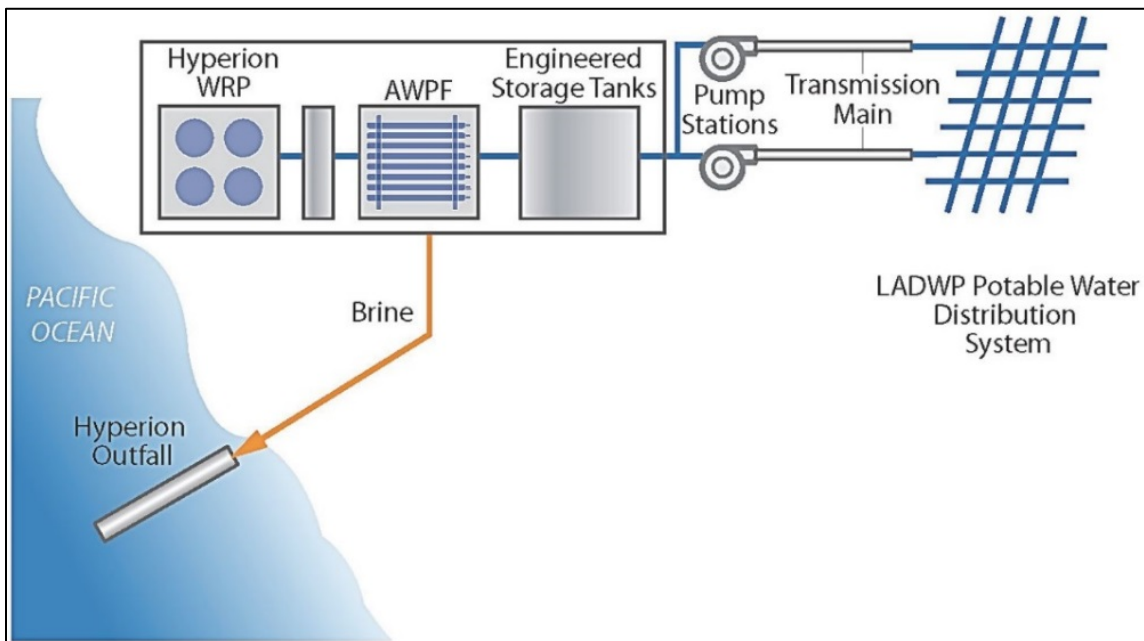
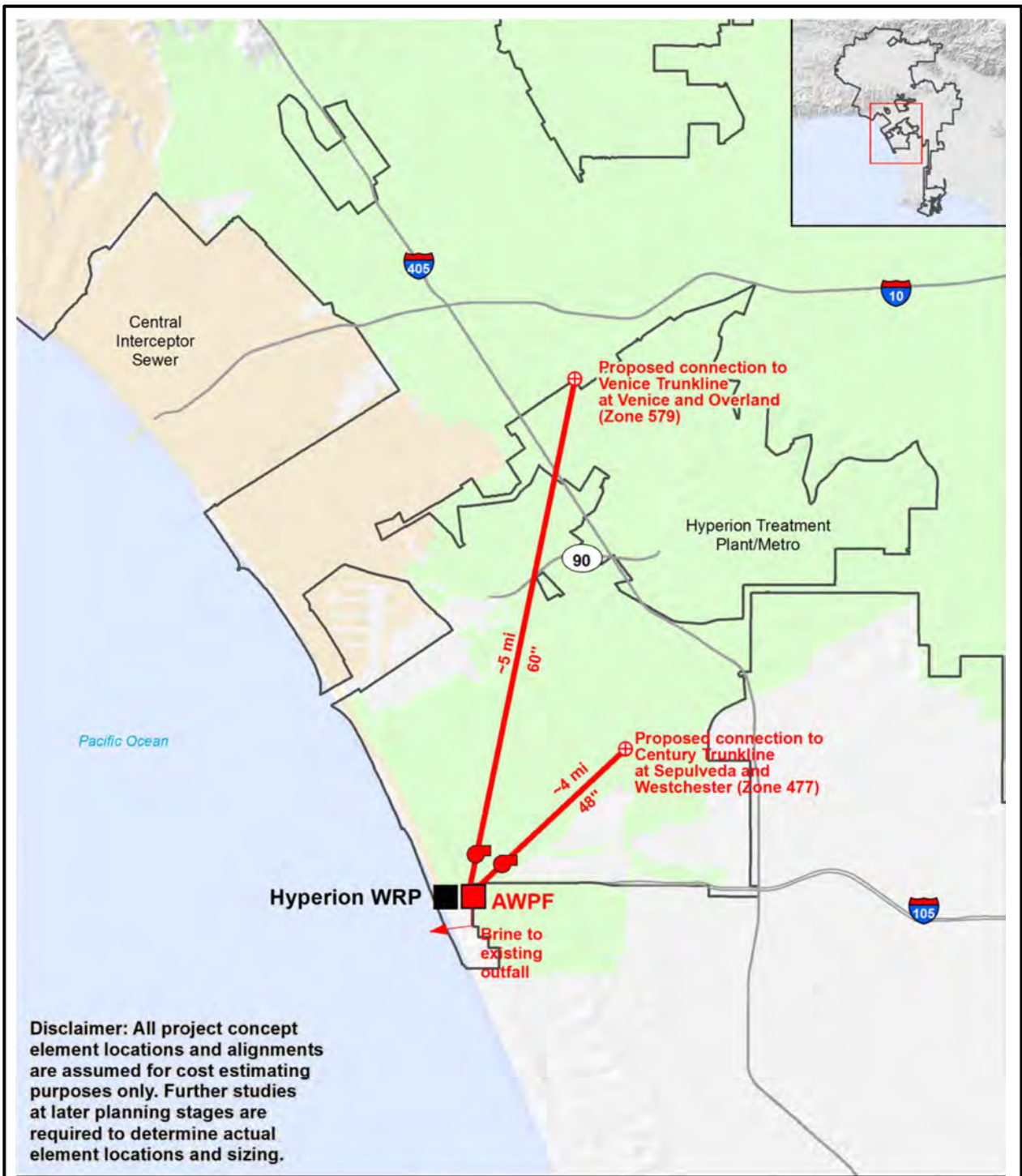

Figure C.13 Process Flow Schematic for Concept Option #18 (HWRP to LADWP Distribution System)

C.4.5.1 System Upgrades

System upgrades to deliver effluent to the system are summarized in Table C.10 and is shown on Figure C.14.

| Table C.10 System Upgrades for Concept Option #18 (HWRP to LADWP Distribution System) Wastewater Facilities Plan One Water LA 2040 Plan | |
|--------------------------------------------------------------------------------------------------------------------------------------------------------|-------------------------------------------------------------|
| Description | Quantity |
| Estimated Yield (Normal/Wet/Dry Year) | 95,000 AFY (85 mgd) |
| Pipelines | 4 miles of 48-inch diameter and 5 miles of 60-inch diameter |



Legend

- Existing Water Reclamation Plant (WRP)
- City of Los Angeles
- Sewershed
- Advanced Water Purification Facility (AWPF)
- Pump Station
- Pipeline
- Connection Point with LADWP system
- Brine



Hillshade Source: CalAtlas
<http://www.atlas.ca.gov>

Figure C.14
System Upgrades for Concept Option #18 (HWRP to LADWP Distribution System)
 One Water LA 2040 Plan

C.4.5.2 HWRP Upgrades

Facility upgrades at HWRP may be required for the implementation of the HWRP to LADWP Distribution System concept. Preliminary details of the upgrades are summarized in Table C.11. The sizing of the equalization basin may require the storage to be located off the HWRP site. Further evaluation needs to be performed to determine the location of the engineered storage tank should this concept option be selected for implementation. The new product water pump station may be located at the location of the engineered water tank. Figure C.15 depicts potential AWPf locations at HWRP.

| Table C.11 Potential Upgrades for Concept Option #18 (HWRP to LADWP Distribution System) Wastewater Facilities Plan One Water LA 2040 Plan | | |
|-----------------------------------------------------------------------------------------------------------------------------------------------------------|-----------------|--------------|
| Description | Quantity | Units |
| Primary Effluent (Feedwater) | 105 | mgd |
| Wastewater Equalization | 25.0 | MG |
| Wastewater Equalization Footprint | 75,000 | sq ft |
| Wastewater Equalization Hydraulic Retention Time | 5.70 | hr |
| Bioreactors to Retrofit | 105 | mgd |
| Bioreactor Trains to Retrofit | 10 | quantity |
| Membrane Separation Footprint | 56,000 | sq ft |
| Membrane Permeate Flow | 100 | mgd |
| WAS Flow | 5 | mgd |
| RO / UV/AOP Permeate Flow | 85 | mgd |
| RO / UV/AOP Footprint | 85,000 | sq ft |
| Brine Flow | 15 | mgd |
| Chemical Facility Footprint | 42,000 | sq ft |
| Secondary Clarifiers Demolition | 183,000 | sq ft |
| Clarifier Modules to Replace (4 per Module) | 2 | quantity |
| Product Water Storage | 85.0 | MG |
| Product Water Storage Footprint | 253,000 | sq ft |
| Product Water Storage Hydraulic Retention Time | 24.00 | hr |
| Pump Station | 14,000 | hp |
| Pump Station Footprint | 11,000 | sq ft |
| Reservoir and PS Area | 264,000 | sq ft |
| Assumptions: | | |
| (1) Wastewater Equalization and Product Water Equalization Tanks are assumed to be 45 ft deep | | |
| (2) Primary influent is assumed at 5% solids | | |
| (3) RO recovery is assumed at 85% | | |
| (4) Footprint for Facilities is based upon Hyperion Reuse Feasibility Study (MWH, May 2016) | | |
| (5) Footprint for Pump Station is based upon Hyperion West Basin Secondary Effluent Pump Station (Bid Documents, April 2017) | | |

Document Path: \\usnv1s01\GIS\GIS_Jobs\City_LA_BOS_MXD\Task7_TM\G\HWRP_PPEB_Ph2_HalfReservoir_20170914.mxd

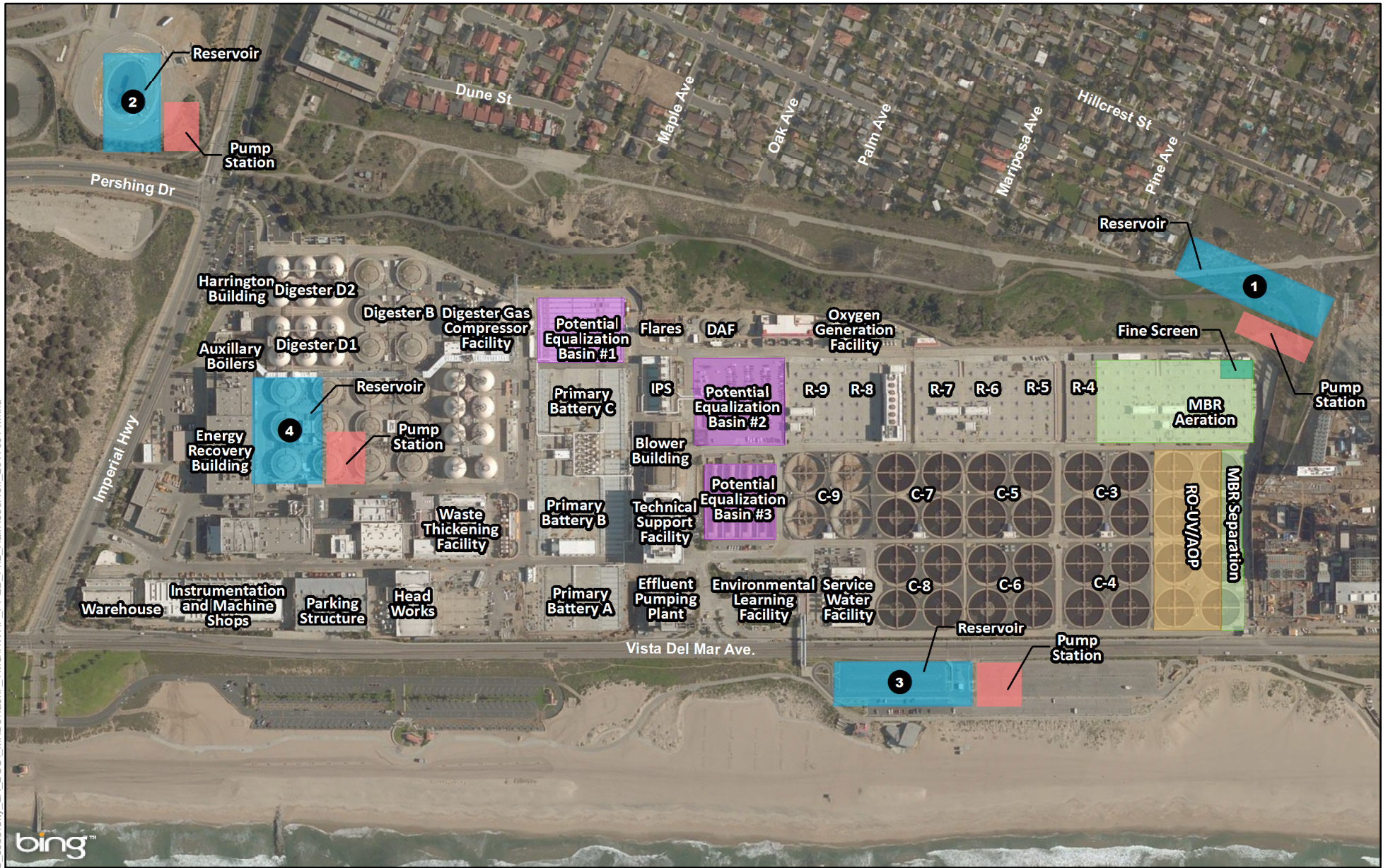

- Reservoir (Options 1-4)
- Potential Primary Equalization Basin
- Fine Screen
- Hyperion Recycled Water Pump Station
- RO-UV/AOP/Chemicals
- MBR

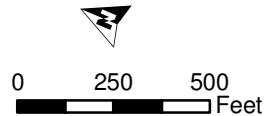

Figure C.15
Potential Upgrades for Concept
Option #18 (HWRP to
Headworks Reservoir)
 One Water LA 2040 Plan

C.4.6 Concept Option #19 (HWRP to Headworks Reservoir)

This concept option could treat the water with an AWPf located at the HWRP. It is estimated that the AWPf would provide FAT and additional processes may be required to comply with future potable reuse with treated water augmentation regulations such as an engineered buffer. To create an engineered buffer, the water would need to be pumped and piped to Headworks Reservoir. The estimated timeline for the HWRP to Headworks Reservoir concept is 2030-2040 and the concept is estimated to yield 95,000 AFY (85 mgd) of potable water during normal years, wet years, and dry years. Figure C.16 shows the overall schematic for the option, with AWT pumped to Headworks Reservoir before being served to LADWP's potable water distribution system.

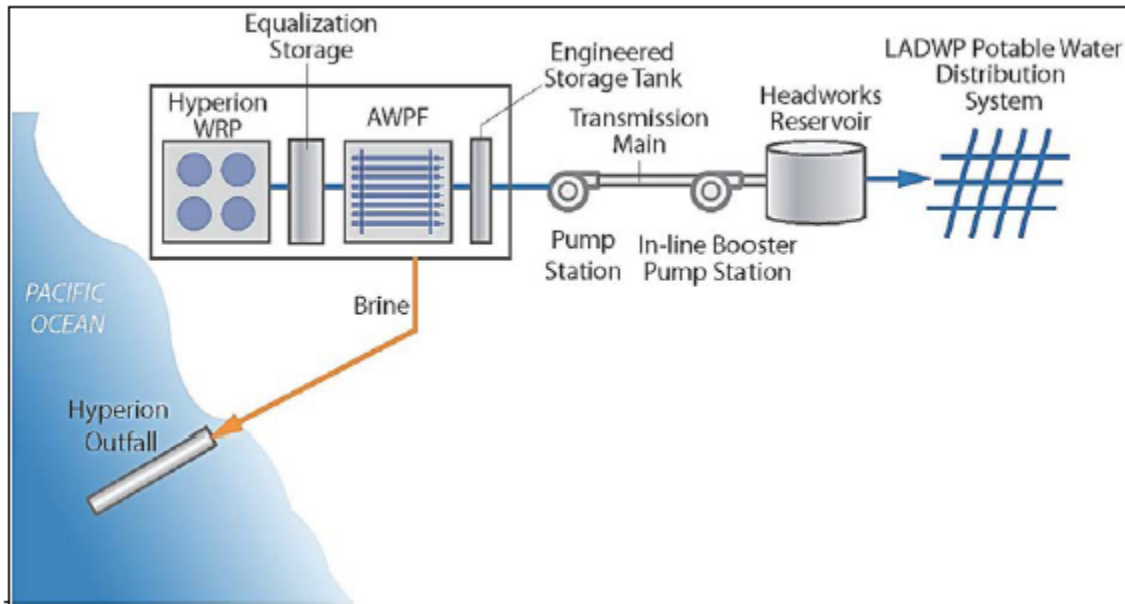
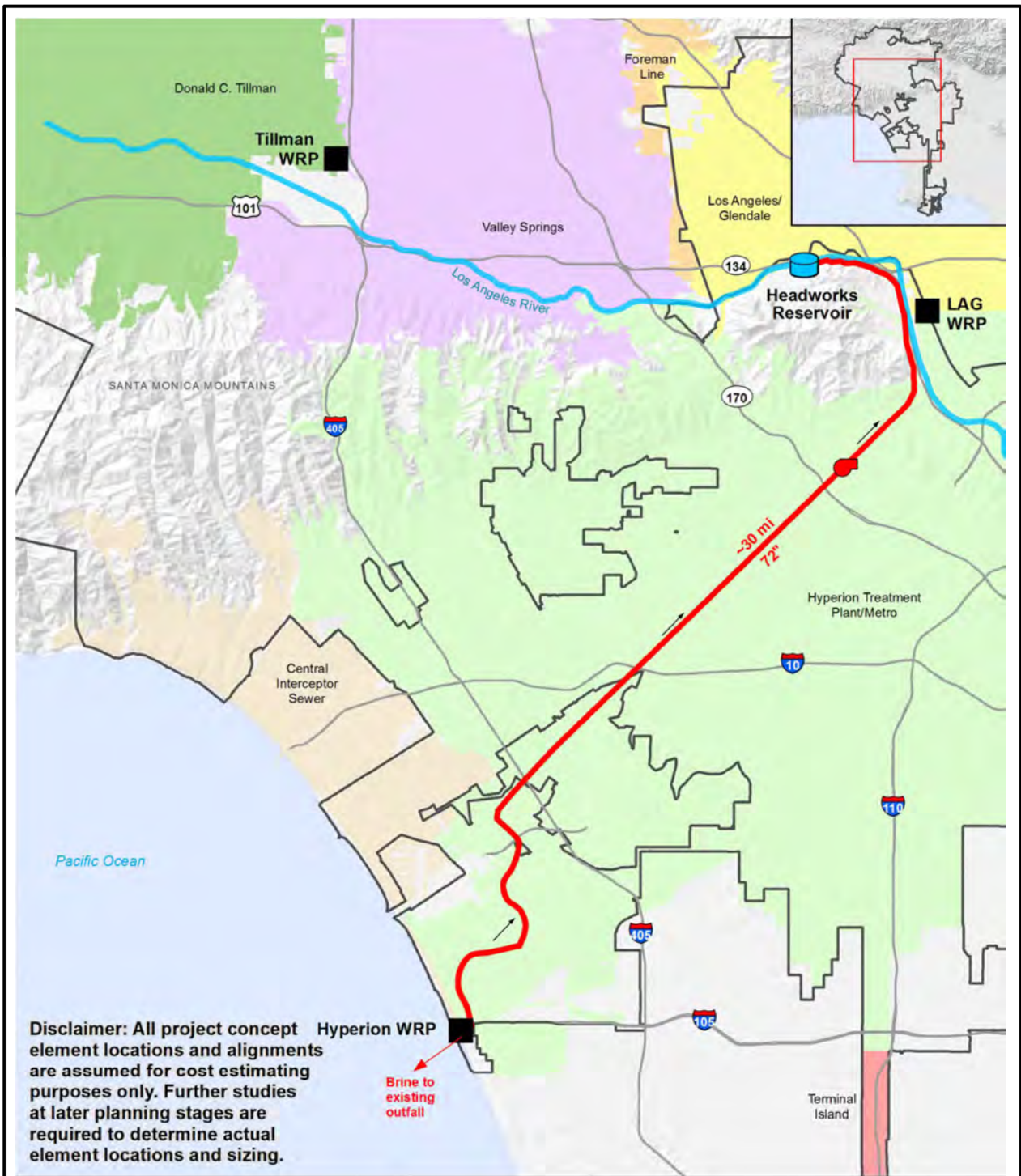

Figure C.16 Process Flow Schematic for Concept Option #19 (HWRP to Headworks Reservoir)

C.4.6.1 System Upgrades

System upgrades may be required for the implementation of the HWRP to Headworks Reservoir concept option are summarized in Table C.12. Figure C.17 shows the conceptual location of the potential system upgrades needed to implement this concept option.

| Table C.12 System Upgrades for Concept Option #19 (HWRP to Headworks Reservoir) Wastewater Facilities Plan One Water LA 2040 Plan | |
|--------------------------------------------------------------------------------------------------------------------------------------------------------------|------------------------------|
| Description | Quantity |
| Estimated Yield (Normal/Wet/Dry Year) | 95,000 AFY (85 mgd) |
| Transmission Pipeline | 30-miles of 72-inch diameter |
| Pump Station | One 8,000 hp |



Legend

- Existing Water Reclamation Plant (WRP)
- City of Los Angeles
- Sewershed
- Existing Reservoir
- Pipeline
- Brine
- Pump Station
- Flow direction

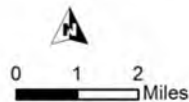

Hillshade Source: CalAtlas
<http://www.atlas.ca.gov>

Figure C.17
System Upgrades for Concept Option #19 (HWRP to Headworks Reservoir)
 One Water LA 2040 Plan

C.4.6.2 HWRP Upgrades

Facility upgrades at HWRP could be required for the implementation of the HWRP to Headworks Reservoir concept. These system upgrades may consist of AWT facilities, primary influent equalization, and product water pump station facilities. Preliminary details of the upgrades are summarized in Table C.13. This concept option could require two equalization tanks. Potential locations for equalization on HWRP site are shown on Figure C.18. The configuration and location of these storage tanks will need to be reviewed and evaluated during detail design should this concept option be selected for implementation. The new product water pump station could be located at the location of the engineered water tank. Figure C.18 depicts potential AWPf locations at HWRP.

| Table C.13 Potential Upgrades for Concept Option #19 (HWRP to Headworks Reservoir) Wastewater Facilities Plan One Water LA 2040 Plan | | |
|-----------------------------------------------------------------------------------------------------------------------------------------------------|-----------------|--------------|
| Description | Quantity | Units |
| Primary Effluent (Feedwater) | 105 | mgd |
| Wastewater Equalization | 25.0 | MG |
| Wastewater Equalization Footprint | 75,000 | sq ft |
| Wastewater Equalization Hydraulic Retention Time | 5.70 | hr |
| Bioreactors to Retrofit | 105 | mgd |
| Bioreactor Trains to Retrofit | 10 | quantity |
| Membrane Separation Footprint | 56,000 | sq ft |
| Membrane Permeate Flow | 100 | mgd |
| WAS Flow | 5 | mgd |
| RO / UV/AOP Permeate Flow | 85 | mgd |
| RO / UV/AOP Footprint | 85,000 | sq ft |
| Brine Flow | 15 | mgd |
| Chemical Facility Footprint | 42,000 | sq ft |
| Secondary Clarifiers Demolition | 183,000 | sq ft |
| Clarifier Modules to Replace (4 per Module) | 2 | quantity |
| Product Water Storage | 13.0 | MG |
| Product Water Storage Footprint | 39,000 | sq ft |
| Product Water Storage Hydraulic Retention Time | 3.7 | hr |
| Pump Station | 18,000 | hp |
| Pump Station Footprint | 14,000 | sq ft |
| Reservoir and PS Area | 53,000 | sq ft |
| Assumptions: | | |
| (1) Wastewater Equalization and Product Water Equalization Tanks are assumed to be 45 ft deep | | |
| (2) Primary influent is assumed at 5% solids | | |
| (3) RO recovery is assumed at 85% | | |
| (4) Footprint for MBR/RO/AOP Facilities is based upon Hyperion Reuse Feasibility Study (MWH, May 2016) | | |
| (5) Footprint for Pump Station is based upon Hyperion West Basin Secondary Effluent Pump Station (Bid Documents, April 2017) | | |

Document Path: \\usinv1s011GIS\GIS\Jobs\City_LA_BOS_MXD\Task7_TM\G\HWRP_PPEB_Ph2_Reservoir_20170914.mxd

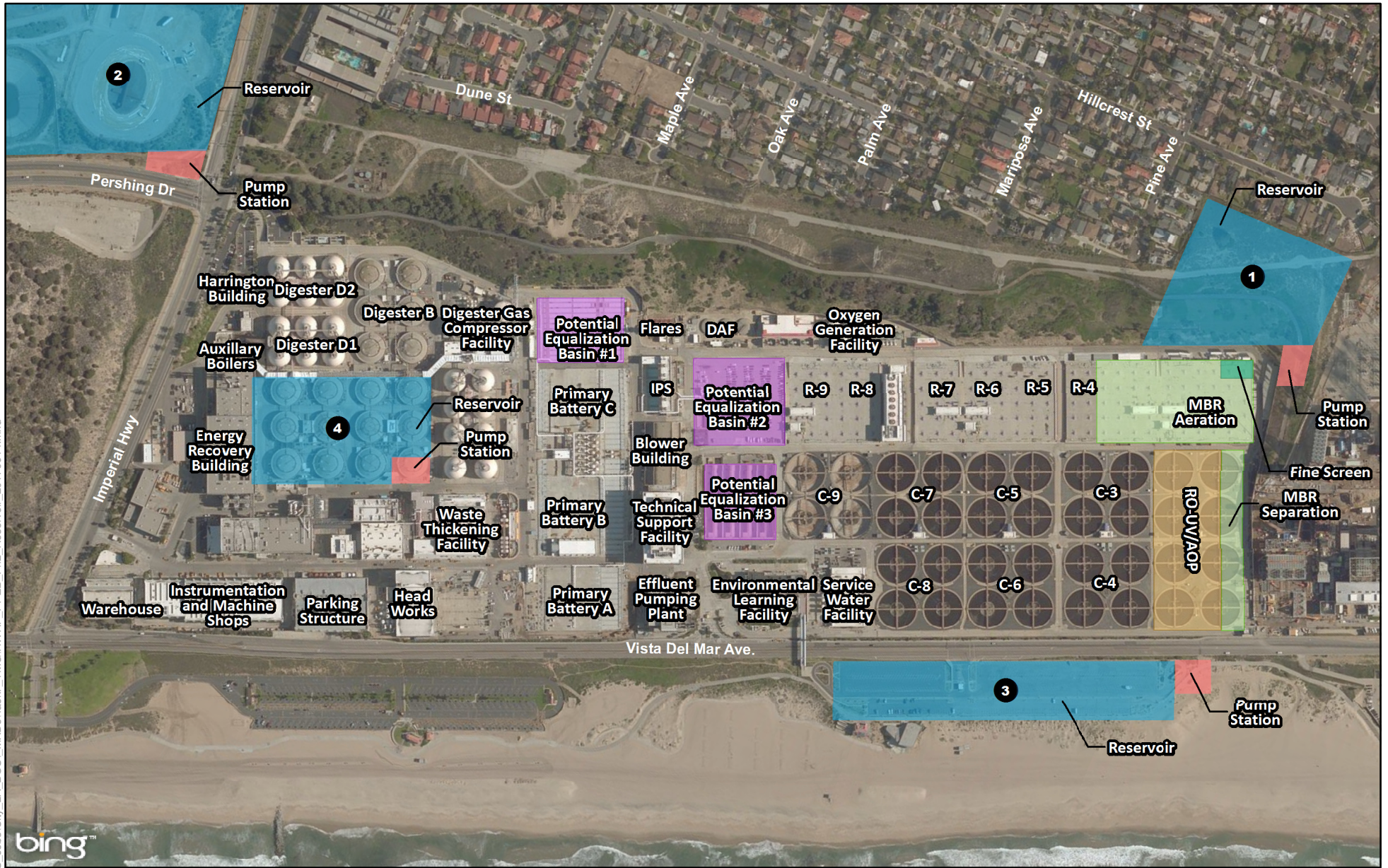

- Reservoir (Options 1-4)
- Potential Primary Equalization Basin
- Fine Screen
- Hyperion Recycled Water Pump Station
- RO-UV/AOP/Chemicals
- MBR

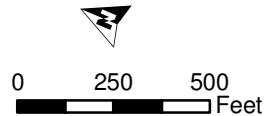

Figure C.18
Potential Upgrades for Concept
Option #19 (HWRP for LADWP
Distribution System)
 One Water LA 2040 Plan

C.4.7 Concept Option #20 (HWRP to LAAFP)

This concept option may further treat effluent from HWRP with AWT. The advanced treated water could then be pump over the Santa Monica Mountains to the San Fernando Valley and on to the LA Aqueduct Filtration Plant (el. 1240 feet). At the LA Aqueduct Filtration Plant, the flow would be mixed with flow from a municipal water district or the LA Aqueduct, retreated, and delivered to the distribution system. It is anticipated that the AWPf would provide FAT and additional processes to comply with future potable reuse with raw water augmentation regulations. Brine produced at the AWPf would be discharged through the 5-mile outfall at HWRP.

The expected timeline for this concept is 2030-2040 and the concept is estimated to yield 95,000 AFY (85 mgd) of potable water during for normal years, wet years, and dry years. Figure C.19 shows an overall schematic of this option.

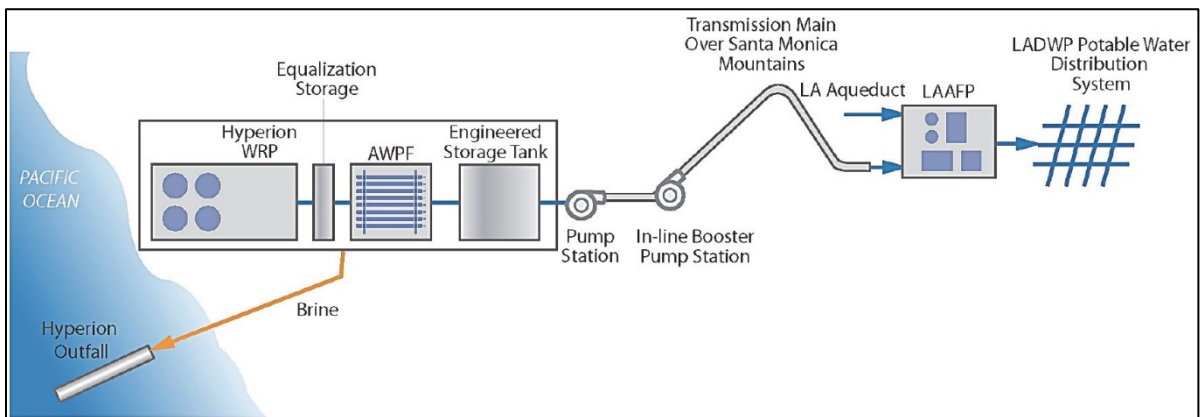
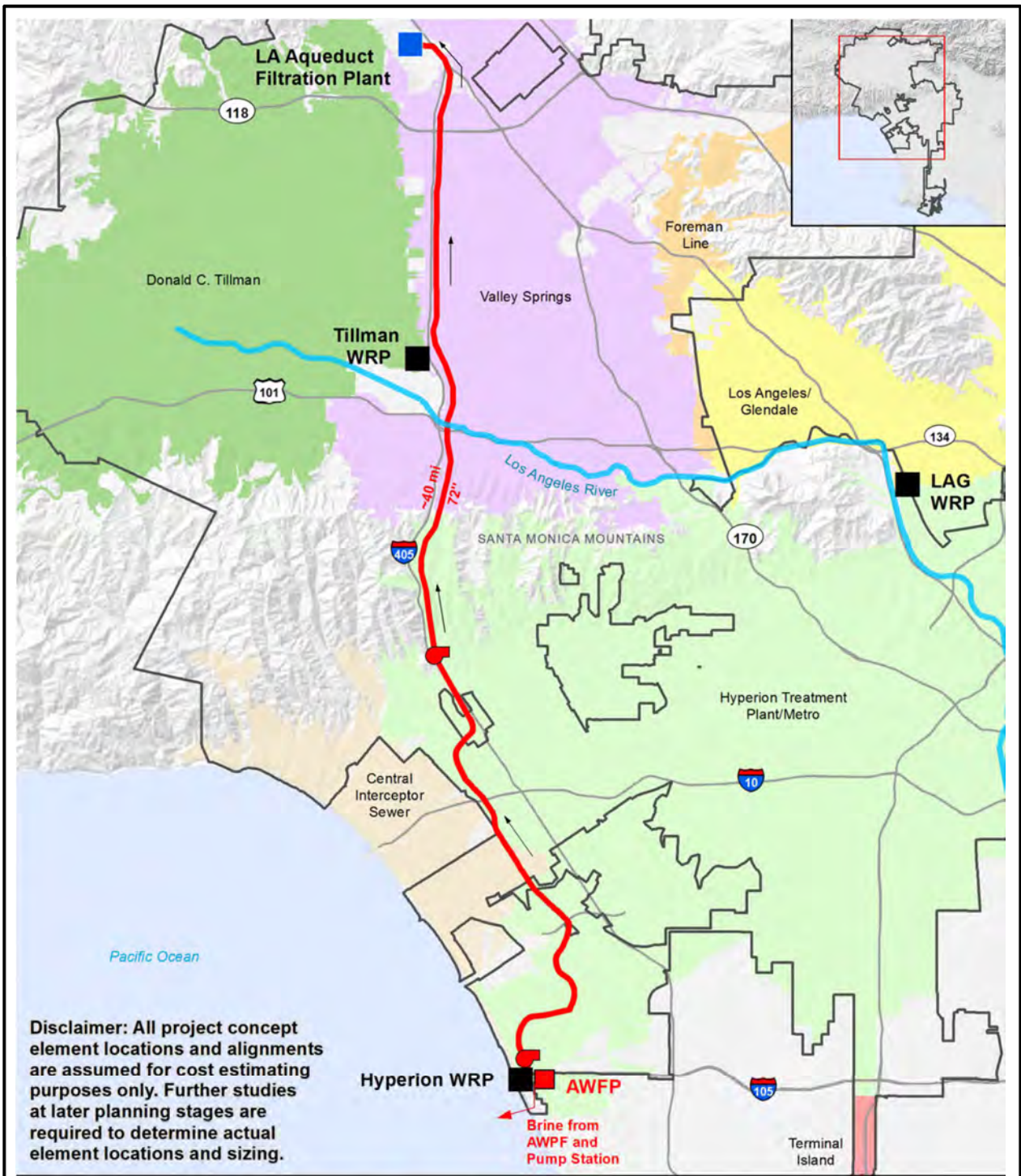

Figure C.19 Process Flow Schematic for Concept Option #20 (HWRP to LA Aqueduct Filtration Plant)

C.4.7.1 System Upgrades

The following Table C.14 provides the potential system upgrades for the implementation of the HWRP to Los Angeles Aqueduct Filtration Plant concept. A system aerial map for the HWRP to Los Angeles Aqueduct Filtration Plant concept is included as Figure C.20.

| Table C.14 System Upgrades for Concept Option #20 (HWRP to Los Angeles Aqueduct Filtration Plant) Wastewater Facilities Plan One Water LA 2040 Plan | |
|--------------------------------------------------------------------------------------------------------------------------------------------------------------------|------------------------------|
| Description | Quantity |
| Estimated Yield (Normal/Wet/Dry Year) | 95,000 AFY (85 mgd) |
| Pipelines | 35 miles of 72-inch diameter |
| Pump Station | One 15,000 hp |



Legend

- | | | | |
|----------------------------------------|---------------------------------------|---------------------------------------------|---------------------------------------------------------------------------------------------|
| Existing Water Reclamation Plant (WRP) | Existing Water Filtration Plant (WRP) | Advanced Water Purification Facility (AWPF) | |
| City of Los Angeles | Flow direction | Pump Station | |
| Sewershed | Pipeline | Brine | Hillshade Source: CalAtlas http://www.atlas.ca.gov |

Figure C.20
System Upgrades for Concept Option #20 (HWRP to Los Angeles Aqueduct Filtration Plant)
 One Water LA 2040 Plan

C.4.7.2 HWRP Upgrades

Facility upgrades at HWRP could be required for the implementation of the HWRP to Los Angeles Aqueduct Filtration Plant concept. These system upgrades may consist of AWT facilities, equalization and product water pump station facilities. Preliminary details of the upgrades are summarized in Table C.15. Further evaluation will need to be performed to determine the location of the engineered storage tank. The new product water pump station may be located at the location of the engineered water tank. Figure C.21 depicts potential AWPf locations at HWRP.

| Table C.15 Potential Upgrades for Concept Option #20 (HWRP to LAAFP) Wastewater Facilities Plan One Water LA 2040 Plan | | |
|---------------------------------------------------------------------------------------------------------------------------------------|-----------------|--------------|
| Description | Quantity | Units |
| Primary Effluent (Feedwater) | 105 | mgd |
| Wastewater Equalization | 25.0 | MG |
| Wastewater Equalization Footprint | 75,000 | sq ft |
| Wastewater Equalization Hydraulic Retention Time | 5.70 | hr |
| Bioreactors to Retrofit | 105 | mgd |
| Bioreactor Trains to Retrofit | 10 | quantity |
| Membrane Separation Footprint | 56,000 | sq ft |
| Membrane Permeate Flow | 100 | mgd |
| WAS Flow | 5 | mgd |
| RO / UV/AOP Permeate Flow | 85 | mgd |
| RO / UV/AOP Footprint | 85,000 | sq ft |
| Brine Flow | 15 | mgd |
| Chemical Facility Footprint | 42,000 | sq ft |
| Secondary Clarifiers Demolition | 183,000 | sq ft |
| Clarifier Modules to Replace (4 per Module) | 2 | quantity |
| Product Water Storage | 85.0 | MG |
| Product Water Storage Footprint | 253,000 | sq ft |
| Product Water Storage Hydraulic Retention Time | 24.00 | hr |
| Pump Station | 20,000 | hp |
| Pump Station Footprint | 16,000 | sq ft |
| Reservoir and PS Area | 269,000 | sq ft |
| <u>Assumptions:</u> | | |
| (1) Wastewater Equalization and Product Water Equalization Tanks are assumed to be 45 ft deep | | |
| (2) Primary influent is assumed at 5% solids | | |
| (3) RO recovery is assumed at 85% | | |
| (4) Footprint for MBR/RO/AOP Facilities is based upon Hyperion Reuse Feasibility Study (MWH, May 2016) | | |
| (5) Footprint for Pump Station is based upon Hyperion West Basin Secondary Effluent Pump Station (Bid Documents, April 2017) | | |

Document Path: \\usinv1s01\GIS\GIS_Jobs\City_LA_BOS_MXDos\Task7_TM\G\HWRP_PPEB_Ph2_HalfReservoir_20170914.mxd

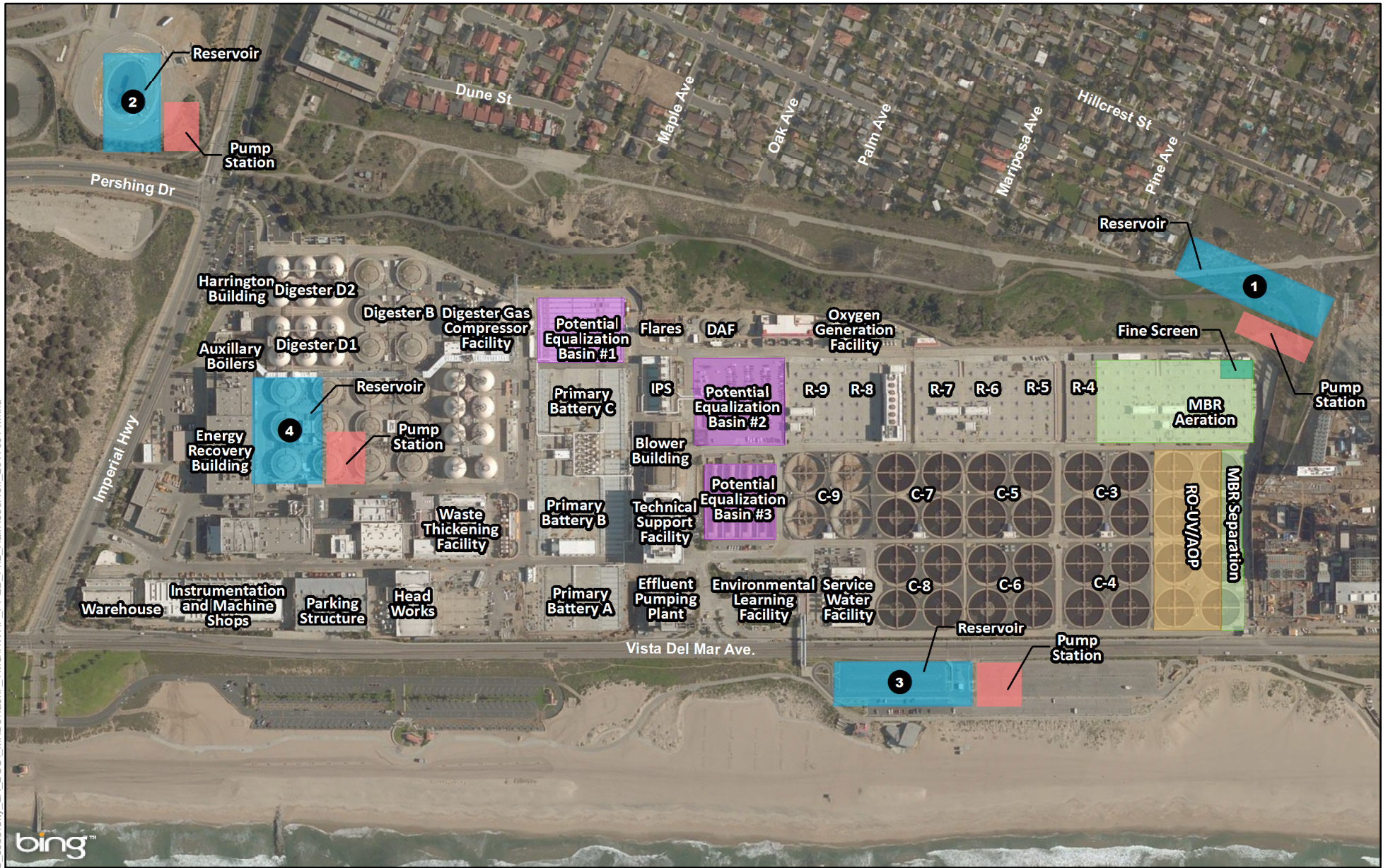

- Reservoir (Options 1-4)
- Potential Primary Equalization Basin
- Fine Screen
- Hyperion Recycled Water Pump Station
- RO-UV/AOP/Chemicals
- MBR

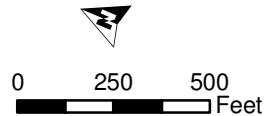

Figure C.21
Potential Upgrades for Concept
Option #20 (HWRP to
Headworks Reservoir)
 One Water LA 2040 Plan

DONALD C. TILLMAN WATER RECLAMATION PLANT CONCEPT OPTIONS

This appendix provides information pertaining to the implementation of those Concept Options developed specifically for DCTWRP. Chapter 5 – Donald C. Tillman Water Reclamation Plant includes an overview of the approach to the development and prioritization of Concept Options. Additionally, the preferred, or selected, approach to optimize reuse from this facility is repeated.

D.1 BACKGROUND

The preliminary list of concept options that support a locally sourced water supply was developed through workshops that solicited ideas and input from a workgroup as well as community stakeholders. This workgroup included contributors from an array of communities, LASAN, LADWP, other City Bureaus and Departments and select technical advisors. These ideas resulted in the development of concept options within the 2040 planning horizon. Concept options represent new concepts that have not been previously evaluated by the City.

With this methodology, a list of 27 concept options was developed for the entire system. Of these 27 concept options, six concept options were related to DCTWRP. Determination of DCTWRP future system needs were based on previous master plans, planning documents, discussions with City staff, and brainstorming sessions. The concept options are preliminary in nature and are not a commitment to level or quantity of treatment. DCTWRP Concept Options

Table D.1 lists the concept options associated with DCTWRP, including the normal year estimated yield and associated capital costs.

| Table D.1 DCTWRP Concept Options Wastewater Facilities Plan One Water LA 2040 Plan | | | | | |
|---------------------------------------------------------------------------------------------------|---------------------------------------------------|---------------------------------------------|--------------------------------------|-----------------------------------------|--------------------------|
| Concept Option # | Title | Strategy | Estimated Yield (Normal Year) | Capital Cost (\$M)⁽¹⁾ | Unit Cost (\$/AF) |
| 7 | Upper Los Angeles River to Tillman WRP | LA River Storage and Use | 5,600 AFY (5 mgd) | \$18 | \$160 |
| 9 | Tillman WRP to San Fernando Basin Injection Wells | Potable Reuse with Groundwater Augmentation | 15,000 AFY (14 mgd) | \$360 | \$1,600 |

| Table D.1 DCTWRP Concept Options Wastewater Facilities Plan One Water LA 2040 Plan | | | | | |
|----------------------------------------------------------------------------------------------------------------------------------------------------------------------------------------------------------------------|-------------------------------------------------------------|--------------------------------------------------|--------------------------------------|-----------------------------------------|--------------------------|
| Concept Option # | Title | Strategy | Estimated Yield (Normal Year) | Capital Cost (\$M)⁽¹⁾ | Unit Cost (\$/AF) |
| 15 | Tillman WRP to Los Angeles Aqueduct Filtration Plant | Potable Reuse with Raw Water Augmentation | 15,000 AFY (14 mgd) | \$310 | \$1,500 |
| 16 | Tillman WRP to LADWP Distribution System | Potable Reuse with Treated Water Augmentation | 15,000 AFY (14 mgd) | \$295 | \$1,300 |
| 22 | East-West Valley Interceptor Sewer | Flow Management | 12,800 AFY (11.41 mgd) | \$85 | \$430 |
| 26 | Japanese Garden & Sepulveda Basin Lakes Recirculation | Flow Management | 20,000 AFY (18 mgd) | \$20 | \$70 |
| <u>Note:</u> | | | | | |
| (1) Total Concept Option cost includes a variety of project components including treatment facilities, conveyance, and injection and extraction facilities. Not all costs pertain to the Wastewater Facilities Plan. | | | | | |
| (2) Bold indicates a Priority A Concept Option | | | | | |

As shown in Table D.1, the Concept Options for DCTWRP involve one of the three reuse strategies:

- Potable reuse with groundwater augmentation - Projects that would spread (infiltrate) or directly inject recycled water into a groundwater basin that could be used as potable water after extraction and further treatment.
- Potable reuse with raw water augmentation - Projects that would deliver advanced treated recycled water (purified water) to a conventional water treatment plant before distributing into a potable water system.
- Potable reuse with treated water augmentation (TWA) - Projects that would deliver advanced treated recycled water (purified water) directly to a potable water system.

While there are differences between the options in terms of capacity, delivery location and ultimate use, all require similar levels of advanced treatment.

D.2 SUMMARY OF THE PREFERRED APPROACH

As part of the WWFP development, each of the concept options listed above was reviewed to identify improvements that would need to be implemented at the plant as well as system changes to convey that product water. This analysis included preliminary sizing of treatment process modifications, location of the processes, and preliminary cost estimates. Based on the overall concept score, cost estimates, and portfolio evaluation results, the concept options were prioritized. The concept options for DCTWRP were prioritized as follows:

- Priority A: Concept Option #15 - Potable Reuse with raw water augmentation from DCTWRP to LAAFP
- Priority B: Concept Option #16 - Potable Reuse with treated water augmentation from DCTWRP to LADWP Distribution System
- Priority C: Concept Option #9 - Potable Reuse with groundwater augmentation from DCTWRP to San Fernando Basin with injection wells

It can be concluded that all concept options involve the installation of additional treatment facilities at DCTWRP to deliver either advanced treated water for the various potable reuse project configurations. In addition, all selected concept options have the same capacity of 15,000 afy. This capacity is based on the estimated available flow from DCTWRP for future water reuse projects after the implementation of flow management options such as Concept Option #5 (Dry Weather Low Flow Diversions), Concept Option #22 (East West Valley Interceptor Sewer), and/or Concept Option #26 (Japanese Garden & Sepulveda Basin Lakes Recirculation)

As shown on Figure D.1, the most critical trigger of any of the Priority A, B, or C options is the ability to increase recycled water flow availability to DCTWRP. Due to the success of water conservation and the ongoing groundwater replenishment project, all existing flows have been accounted for. Hence, the first trigger is a decision to pursue and implement a flow management project to divert additional wastewater flows to DCTWRP. Once the City makes this decision, the next trigger is the approval of a wastewater change petition from the Division of Water Rights per Water Code Section 1211 to allow a reduction in effluent discharge from DCTWRP to the LA River.

If this petition is approved, the City could proceed with Concept Option #26. By implementing some type of flow recirculation project for the Japanese Garden and Sepulveda Basin Lakes, a portion of the DCTWRP effluent that is currently discharged into the LA River could be repurposed for potable reuse.

If this petition is not approved, the City would need to proceed with Concept Option #22 and increase flow availability to DCTWRP by constructing the EWWIS project, which consist of a 6-mile sewer forcemain and six lift stations to bring wastewater flows from the eastern part of the San Fernando Valley to DCTWRP.

The next most critical triggers are related to the adoption of potable reuse regulations. The highest ranked potable reuse opportunity (Concept Option #15 - DCTWRP to LAAFP) would require acceptance of potable reuse with raw water augmentation, while the second highest concept option (#16 - DCTWRP to Distribution System) would require acceptance of potable reuse with treated water augmentation. In case the potable regulations are not accepted within a desired timeframe or if the City prefers a more conventional form of water reuse, the third best potable reuse option from DCTWRP is Concept Option #9 (Groundwater Augmentation from DCTWRP to San Fernando Basin Injection Wells). If none of the flow management strategies are feasible nor the potable reuse regulations are approved, it is recommended to postpone any new water reuse projects from DCTWRP. This decision is indicated as "No Change" on Figure D.1.

However, triggers, underlying conditions, and assumptions made for the development of these concept options are likely to change in the future. It is therefore recommended that City staff closely monitor all triggers and other circumstances that may impact the viability and prioritization of all concept options developed for DCTWRP. Future changed conditions may not only change the prioritization of the concept options included as Priority A, B, and C, but also impact the viability of the four other potable reuse options from DCTWRP that have not yet been identified in this plan.

D.3 CONCEPT OPTION IMPLEMENTATION

Each of the six DCTWRP concept options is discussed in the following subsection. Included are:

- General narrative description of Concept Option
- Concept schematic
- System requirements for improvement needed to implement
- Location map depicting DCTWRP and end use
- Outline of required upgrades to DCTWRP to accommodate option
- Site plan of DCTWRP highlighting areas impacted

The information provided pertains to the selected option as well as those not selected.

Donald C. Tillman Water Reclamation Plant

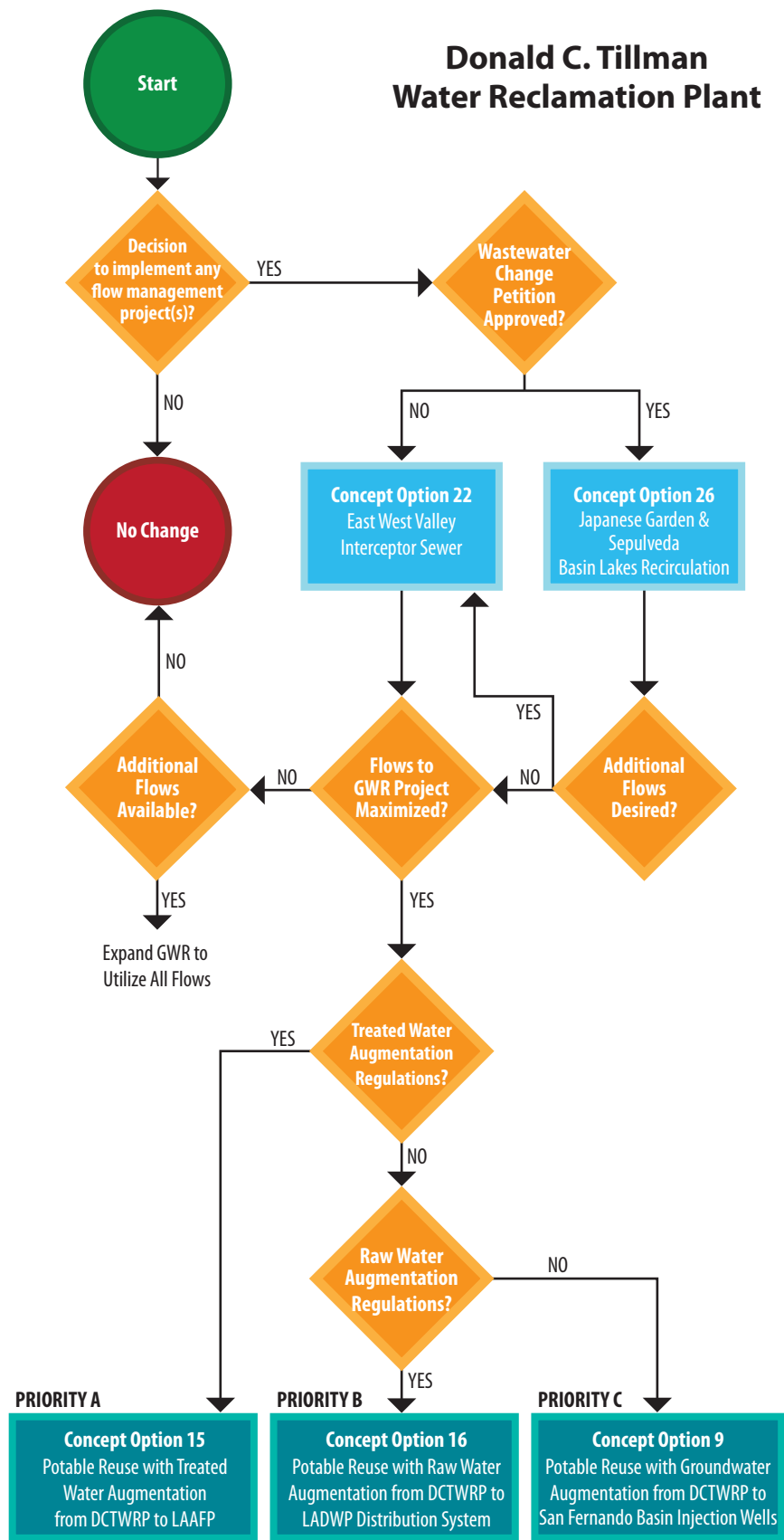

LEGEND & ACRONYMS

- ◆ Trigger
- Concept Option
- Flow Management Option

DCTWRP Donald C. Tillman Water Reclamation Plant
 GWR Groundwater Replenishment Project
 HWRP Hyperion Water Reclamation Plant
 LAGWRP LA-Glendale Water Reclamation Plant
 RWQCB Regional Water Quality Control Board
 TIWRP Terminal Island Water Reclamation Plant
 WRD Water Replenishment District of Southern California

Disclaimer: At each trigger (decision point), evaluate all triggers and concept option priorities to consider changed circumstances in the future.

Figure D.1
Trigger-Based Implementation Strategy for DCTWRP
 One Water LA 2040 Plan
 Summary Report

D.3.1 Potential Future Treatment Plant Modifications

The following concept options assume that the GWR Project and has been completed and produces up to 30,000 AFY (27 mgd) of purified water for groundwater replenishment. The presented concept options would be in addition to the GWR Project implementation. Multiple concept options also require the EWVIS to be already implemented to provide sufficient wastewater flows for reuse. Evaluation of the concept options are part of the portfolio development, found in Volume 5.

D.3.2 Concept Option #7 (Upper Los Angeles River to DCTWRP)

The LA River upstream of Lake Balboa in the San Fernando Valley has existing natural flow that could be diverted to DCTWRP for treatment and reuse. This increased flow to DCTWRP could be utilized by an alternative potable reuse concept option. Additional discussion of the LA River can be found in TM 12.4 – LA River Special Study.

This concept option is estimated to yield 5,600 AFY (5 mgd) in both a normal or wet year, while a dry year is estimated to yield 4,500 AFY (4 mgd). Estimated yield in a wet or normal year are equivalent due to limitations in facility capacity, whereas dry year yield is assumed to be 80 percent of the normal year flow. The general expected timeframe for this project concept, if implemented, is between 2020 to 2030. Figure D.2 shows a concept flow schematic of this overall concept.

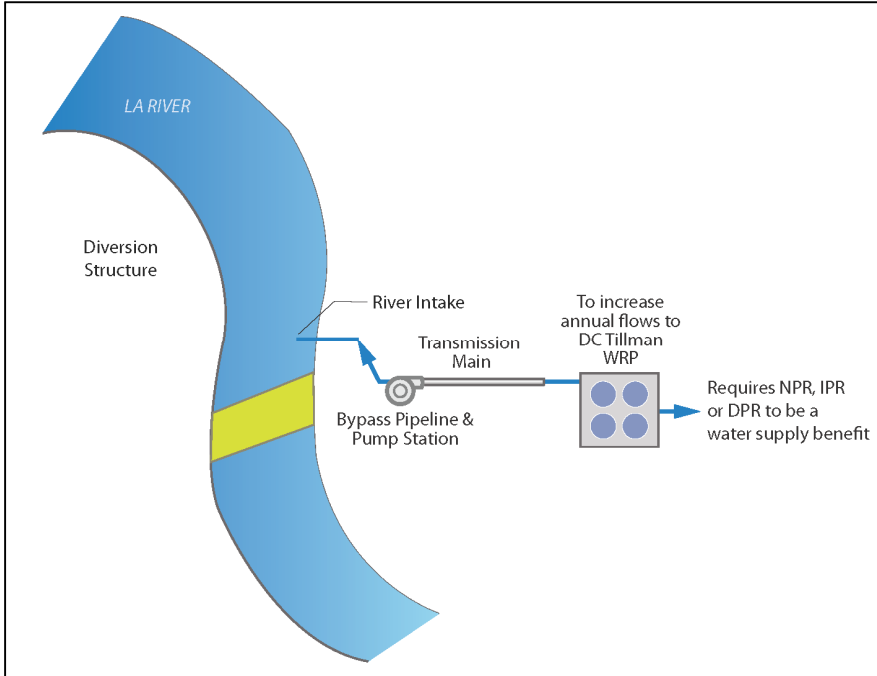

Figure D.2 Process Flow Schematic for Concept Option #7 (Upper Los Angeles River to DCTWRP)

D.3.2.1 System Upgrades

In order to capture the flow in the LA River, a diversion structure, such as a collapsible rubber dam, would need to be installed upstream of Lake Balboa. This diversion structure placed in the river could allow flow to be pumped from the LA River to a pipeline, and then conveyed to DCTWRP. Additional infrastructure may be needed to convey flows to DCTWRP, as summarized in Table D.2. Figure D.3 shows a conceptual level system aerial map for this concept option.

| Table D.2 System Upgrades for Concept Option #7 (Upper Los Angeles River to DCTWRP) Wastewater Facilities Plan One Water LA 2040 Plan | |
|------------------------------------------------------------------------------------------------------------------------------------------------------|---------------------------|
| Description | Quantity |
| Estimated Yield (Normal/Wet Year) | 5,600 AFY (5 mgd) |
| Estimated Yield (Dry Year) | 4,500 AFY (4 mgd) |
| Diversion Structure | 1 in quantity |
| Pump Station | 1 in quantity, 100 hp |
| Pipeline | 3 miles, 20-inch diameter |

D.3.2.2 DCTWRP Upgrades

Implementation of this concept option could yield additional flows to DCTWRP. No potential upgrades have been identified for implementation of this concept option.

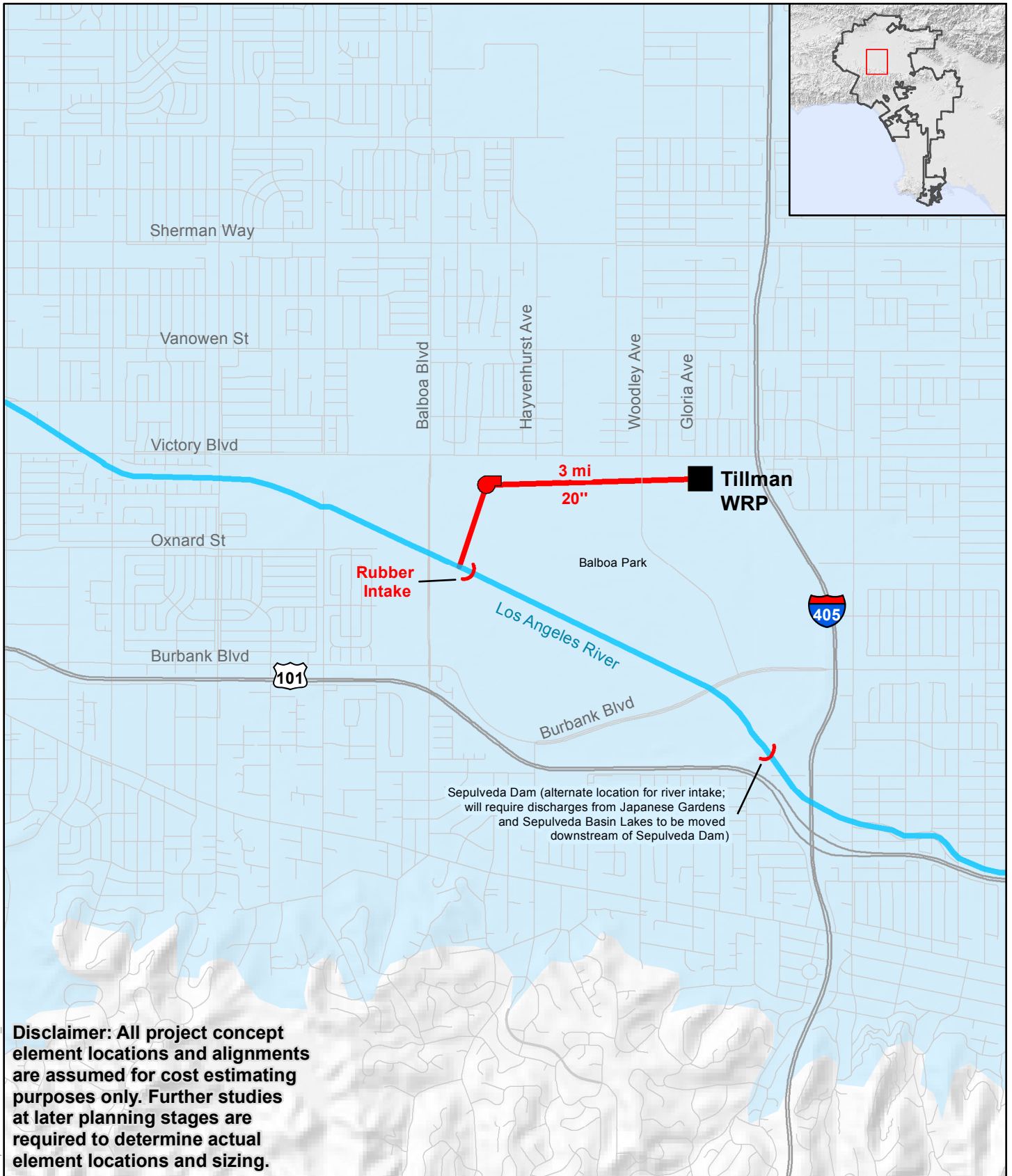
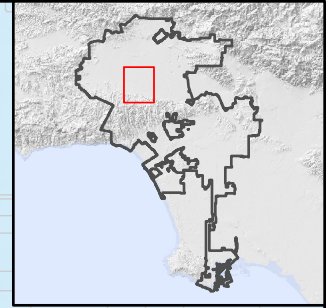

Disclaimer: All project concept element locations and alignments are assumed for cost estimating purposes only. Further studies at later planning stages are required to determine actual element locations and sizing.

Legend

- Existing Water Reclamation Plant (WRP)
- City of Los Angeles
- Groundwater Basin Source: LACDPW
- Pump Station
- Pipeline
- Dam

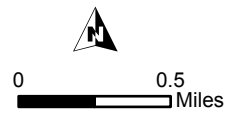

Hillshade Source: CalAtlas
<http://www.atlas.ca.gov>

Figure D.3
System Upgrades for
Concept Option #7
(Upper Los Angeles River to DCTWRP)
 One Water LA 2040 Plan

D.3.3 Concept Option #9 (DCTWRP to San Fernando Basin Injection Wells)

This concept option could utilize the AWPf at DCTWRP to treat water for potable reuse with groundwater augmentation. Purified water could be conveyed through a new recycled water pipeline and ancillary lateral piping to a series of injection wells for aquifer and basin replenishment, and subsequent recovery via production wells. This concept option could yield up to 15,000 AFY (14 mgd) of advanced treated water during normal, wet, and dry years. The expected timeline for the implementation would be 2025 or later, as it would be dependent on completion of the GWR Project and the EWVIS. The process concept flow schematic for this concept option is shown in Figure D.4.

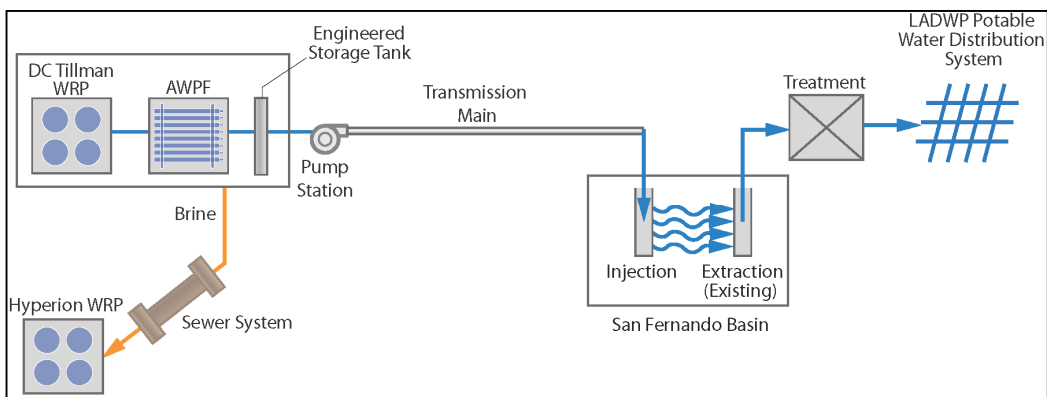

Figure D.4 Process Flow Schematic for Concept Option #9 (DCTWRP to SF Basin Injection Wells)

D.3.3.1 System Potential Upgrades

Additional system infrastructure may be required for implementation of this concept option. To convey purified water to the injection wells, a new pump station, recycled water pipeline, and lateral pipeline could be needed. Six new injection wells would be designed to recharge 15,000 AFY (14 mgd), with an operational capacity of approximately 2.5 mgd per well. Existing groundwater production could be utilized by LADWP for extraction and potable reuse, assuming that any contamination in unused wells would be addressed. Table D.3 summarizes the potential system upgrades needed for implementation of this concept option. Figure D.5 shows a system aerial map depicting conceptual locations of the upgrades.

| Table D.3 System Requirements for Concept Option #9 (DCTWRP to San Fernando Basin Injection Wells) Wastewater Facilities Plan One Water LA 2040 Plan | |
|---------------------------------------------------------------------------------------------------------------------------------------------------------------------|--------------------------------------------------|
| Description | Quantity |
| Estimated Yield (Wet/Normal/Dry) | 15,000 AFY (14 mgd) |
| Pump Station | 1 in quantity, 3,500 hp |
| Recycled Water Pipeline | 10 miles, 30-inch diameter |
| Lateral Pipeline | 3 miles, 12-inch diameter |
| Injection Wells | 6 in quantity, 2.5 mgd operational capacity each |

D.3.3.2 DCTWRP Potential Upgrades

Implementation of this concept option may require expansion of GWR AWPf beyond the planned capacity. Potential influent quantities, estimated yield, and brine/solids to be discharged to DCTWRP for this concept option is detailed in Table D.4.

| Table D.4 AWPf Expansion Summary Wastewater Facilities Plan One Water LA 2040 Plan | | | |
|--------------------------------------------------------------------------------------------------------------------------------------------------------------------------------------------------------------------------------------|---------------------|------------------------|-------------------------------|
| Facility | Influent | Estimated Yield | Brine/Solids to DCTWRP |
| GWR AWPf | 45,000 AFY (44 mgd) | 35,000 AFY (31.3 mgd) | 10,000 AFY (9 mgd) |
| AWPf Expansion | 19,000 AFY (17 mgd) | 15,000 AFY (14 mgd) | 4,000 AFY (3 mgd) |
| Note: | | | |
| (1) Per Los Angeles Groundwater Replenishment Project EIR (May 2016), GWR AWPf will yield 35,000 AFY of purified water, of which 5,000 AFY will be used for NPR uses and 30,000 AFY will be used for groundwater replenishment uses. | | | |

The treatment process of the potential AWPf expansion is assumed to be the same treatment train as the GWR AWPf. To ensure flow equalization upstream of the AWPf expansion, a 2 MG storage tank would need to be added to DCTWRP. Preliminary design criteria is shown in Table D.5. Potential locations for the DCTWRP upgrades are shown on Figure D.6.

| Table D.5 Design Criteria for Concept Option #9 (DCTWRP to San Fernando Basin Injection Wells) Wastewater Facilities Plan One Water LA 2040 Plan | | |
|-----------------------------------------------------------------------------------------------------------------------------------------------------------------|--------------|-----------------|
| Description | Units | Quantity |
| Tertiary Effluent (Feedwater) | mgd | 17 |
| MF/UF Permeate Flow ⁽¹⁾ | mgd | 16 |
| MF/UF Footprint | sq ft | 8,000 |

| Table D.5 Design Criteria for Concept Option #9 (DCTWRP to San Fernando Basin Injection Wells) Wastewater Facilities Plan One Water LA 2040 Plan | | |
|-------------------------------------------------------------------------------------------------------------------------------------------------------------------------------------------------------------------------------------------|--------------|-----------------|
| Description | Units | Quantity |
| RO/UV/AOP Permeate Flow ⁽²⁾ | mgd | 14 |
| RO/UV/AOP Footprint | sq ft | 14,000 |
| Chemical Facility Footprint | sq ft | 14,000 |
| Product Water Storage | MG | 1.0 |
| Product Water Storage Footprint | sq ft | 6,000 |
| Notes: | | |
| (1) MF Recovery is assumed at 93% | | |
| (2) RO Recovery is assumed at 85% | | |
| (3) MF and RO recovery rates are consistent with Los Angeles GWR EIR, May 2016 | | |
| (4) Process sizing is based off assumptions in Section 2 and the San Diego PureWater Program which has a similar process train. | | |
| (5) Footprint sizes are estimated based on general process, electrical and instrumentation equipment that would be required. These estimates are conservative and would be further refined during detailed design upon project selection. | | |

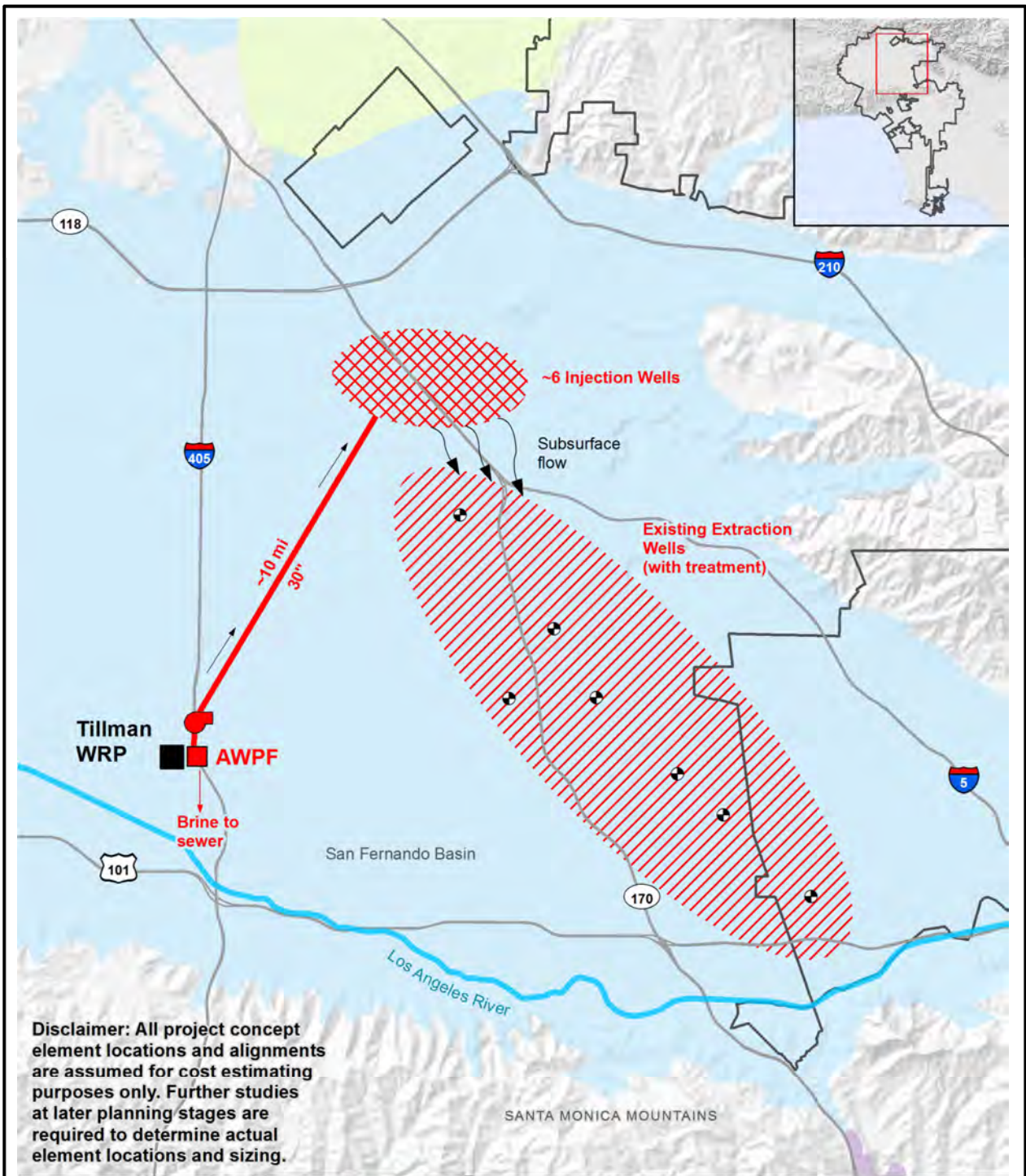

Legend

- Existing Water Reclamation Plant (WRP)
- City of Los Angeles
- Groundwater Basin Source: LACDPW
- Existing Extraction Well
- Flow direction
- Subsurface flow
- Pump Station
- Pipeline
- Injection Well Area
- Extraction Area



Hillshade Source: CaAtlas
<http://www.atlas.ca.gov>

Figure D.5
System Upgrades for Concept Option #9
(DCTWRP to San Fernando Basin Injection Wells)
 One Water LA 2040 Plan

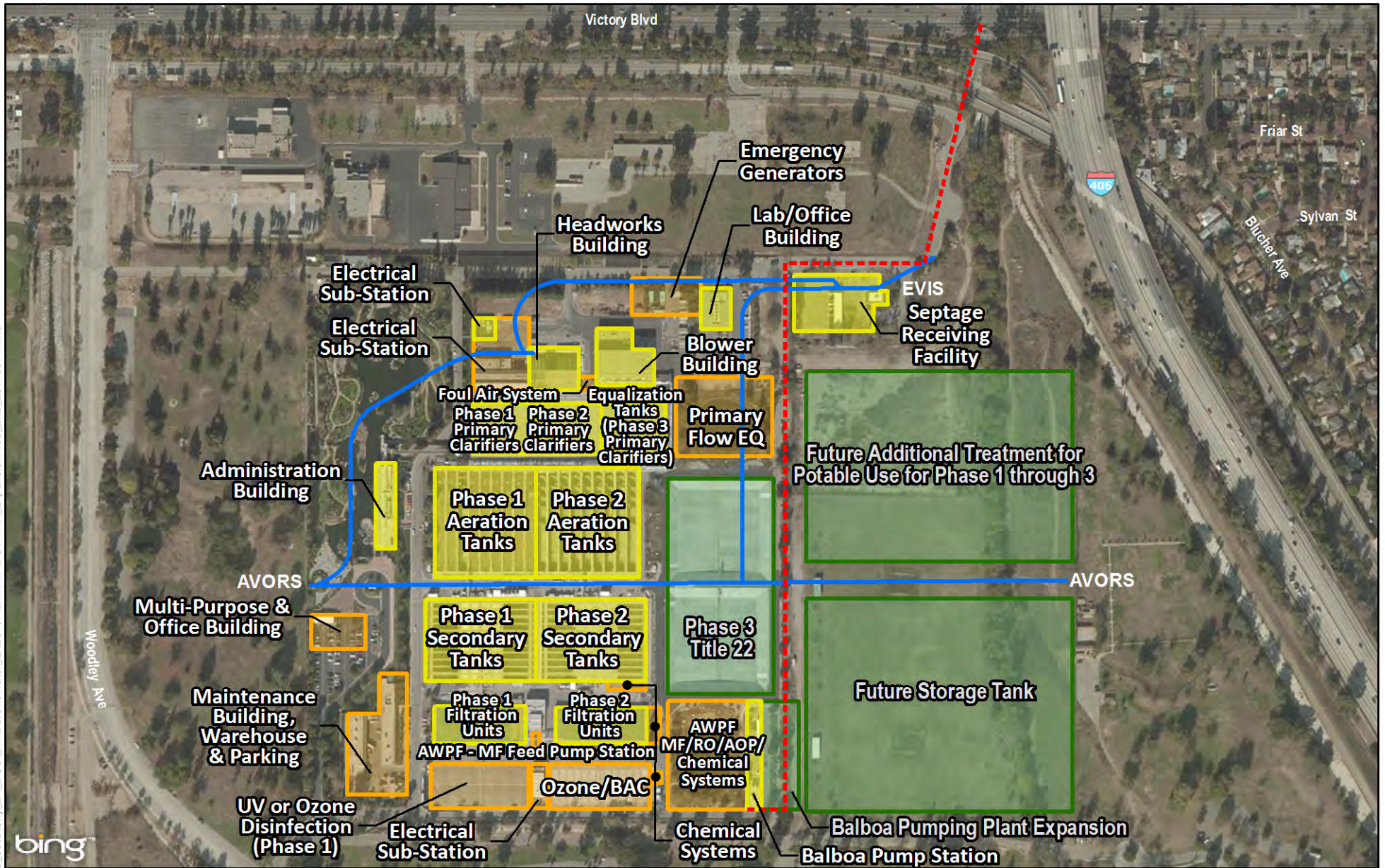

- - - Proposed Brine Line
- AVORS and EVIS
- Existing Facility
- Year 2025 Facility
- Long Term Expansion



Figure D.6
Potential Upgrades for Concept
Option #9
(DCTWRP to San Fernando
Basin Injection Wells)
 One Water LA 2040 Plan

D.3.4 Concept Option #15 (DCTWRP to LA Aqueduct Filtration Plant)

The DCTWRP currently produces recycled water for non-potable water uses. As part of the In-Progress GWR Project, an AWPf is planned to be built at the DCTWRP to provide full advanced treatment. From the DCTWRP AWPf, treated water meeting potable reuse standards would be pumped to the LAAFP. This concept would include expansion of the AWPf facilities and additional processes likely required to comply with anticipated future potable reuse with raw water augmentation regulations. This concept option is estimated to yield 15,000 AFY (14 mgd) of advanced treated water during normal, wet, and dry years. The expected timeline for the implementation would be between 2035 and 2040. Figure D.7 shows the overall process concept flow schematic for this concept.

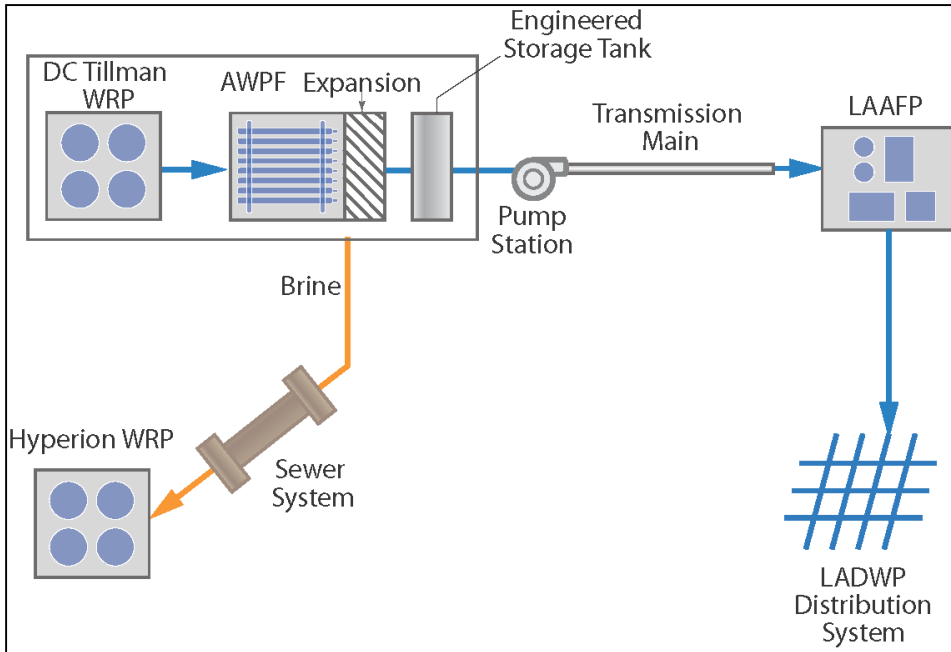
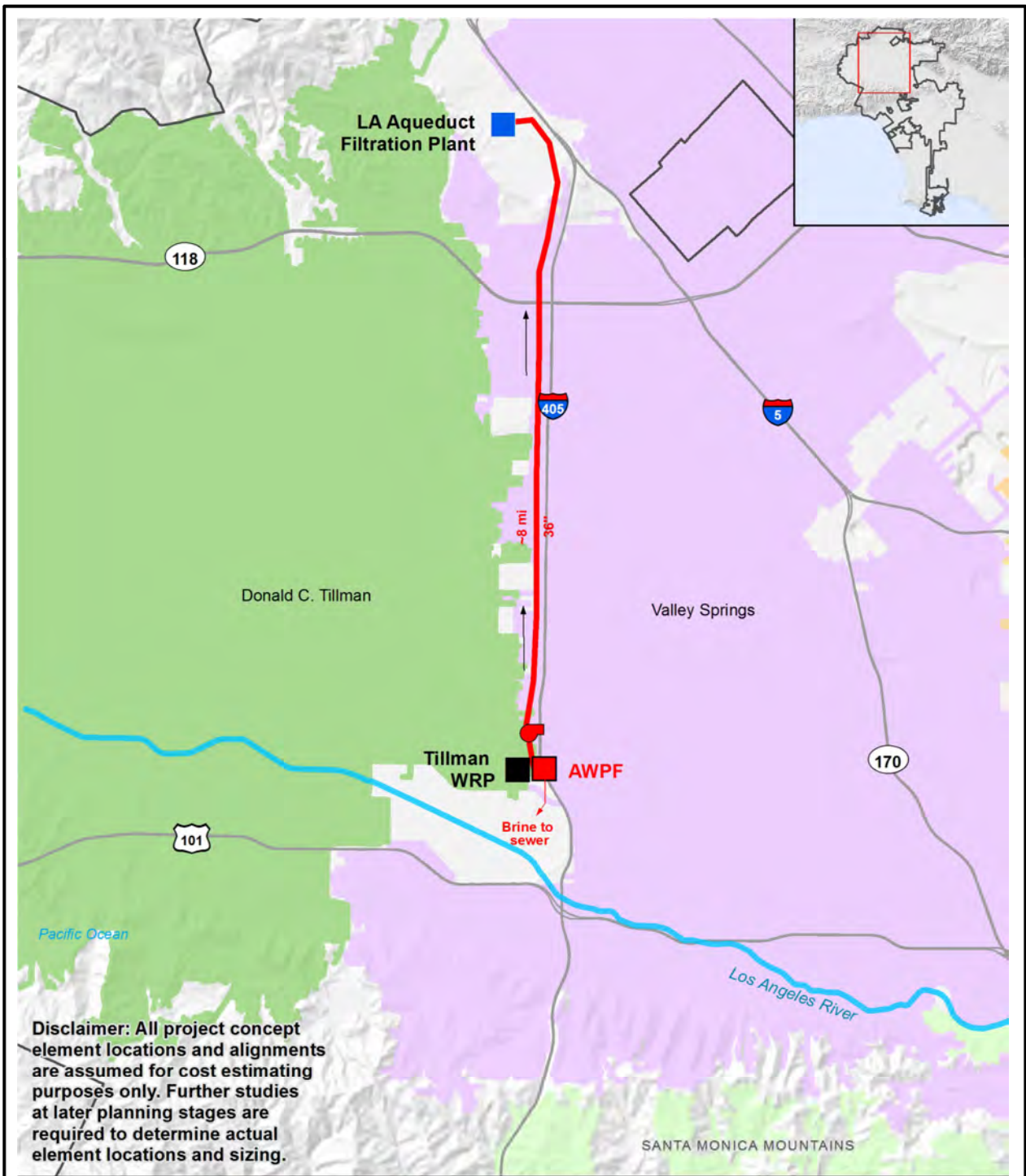

Figure D.7 Process Flow Schematic for Concept Option # 15 (DCTWRP to LAAFP)

D.3.4.1 System Upgrades

Additional system upgrades for this concept option may include a pump station and transmission pipeline to convey the water from the AWPf to the LAAFP. Table D.6 summarizes the potential system upgrades that may be needed for implementation. Figure D.8 shows a conceptual system aerial map.

| Table D.6 System Upgrades for Concept Option # 15 (DCTWRP to LAAFP) Wastewater Facilities Plan One Water LA 2040 Plan | |
|------------------------------------------------------------------------------------------------------------------------------|---------------------------|
| Description | Quantity |
| Estimated Yield (Wet/Normal/Dry) | 15,000 AFY (14 mgd) |
| Pump Station | 1 in quantity, 2,500 hp |
| Transmission Pipeline | 8 miles, 36-inch diameter |



Legend

- Existing Water Reclamation Plant (WRP)
- Existing Water Filtration Plant (WRP)
- Advanced Water Purification Facility (AWPF)
- City of Los Angeles
- Flow direction
- Pump Station
- Pipeline
- Brine
- Groundwater Basin Source: LACDPW

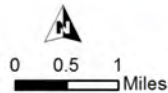

Hillshade Source: CalAtlas
<http://www.atlas.ca.gov>

Figure D.8
System Upgrades for Concept Option #15
(DCTWRP to LA Aqueduct Filtration Plant)
 One Water LA 2040 Plan

D.3.4.2 DCTWRP Upgrades

Implementation of this concept may require an expansion of the GWR AWPf. This project would yield 15,000 AFY (14 mgd) of purified water, with solids discharged downstream to the existing sewer system for treatment at the DCTWRP. In addition to increased capacity of the AWPf, any additional processes likely required to comply with future anticipated potable reuse raw water augmentation regulations would need to be added to DCTWRP. These processes are unknown as the regulations are in development. A 2 MG tertiary effluent equalization tank may also need to be added upstream to the AWPf expansion in order to operate the processes at a constant flow.

Table D.7 summarizes the influent, estimated yield, and brine quantities associated with the planned GWR AWPf and the necessary expansion.

| Table D.7 Potential Upgrades for Concept Option # 15 (DCTWRP to LAAFP) Wastewater Facilities Plan One Water LA 2040 Plan | | | |
|--------------------------------------------------------------------------------------------------------------------------------------------------------------------------------------------------------------------------------------|------------------------|--------------------------|-------------------------------|
| Facility | Influent | Estimated Yield | Brine/Solids to DCTWRP |
| GWR AWPf | 45,000 AFY (44 mgd) | 35,000 AFY (31.3 mgd) | 10,000 AFY (9 mgd) |
| AWPF Expansion | 19,000 AFY (17 mgd) | 15,000 AFY (14 mgd) | 4,000 AFY (3 mgd) |
| Note: | | | |
| (1) Per Los Angeles Groundwater Replenishment Project EIR (May 2016), GWR AWPf will yield 35,000 AFY of purified water, of which 5,000 AFY will be used for NPR uses and 30,000 AFY will be used for groundwater replenishment uses. | | | |

Preliminary design criteria yielding an approximate footprint needed is shown in Table D.8. Figure D.9 shows a potential location for the plant upgrades, should this concept be implemented.

| Table D.8 Potential Upgrades for Concept Option # 15 (DCTWRP to LAAFP) Wastewater Facilities Plan One Water LA 2040 Plan | | |
|---------------------------------------------------------------------------------------------------------------------------------|--------------|-----------------|
| Description | Units | Quantity |
| Tertiary Effluent (Feedwater) | mgd | 17 |
| Ozone Dose | mg/L | 10 |
| Generator Size | lbs/day | 730 |
| Generator Number | | 2+1 |
| Generator Footprint | sq ft | 2,700 |
| Ozone Contactor | | Serpentine |

| Table D.8 Potential Upgrades for Concept Option # 15 (DCTWRP to LAAFP) Wastewater Facilities Plan One Water LA 2040 Plan | | |
|-------------------------------------------------------------------------------------------------------------------------------------------------------------------------------------------------------------------------------------------|--------------|-----------------|
| Description | Units | Quantity |
| Number | | 2+1 |
| Ozone Contactor Footprint | sq ft | 2,700 |
| Ozone gas concentration | % | 12 |
| Days of Storage | days | 7 |
| Required Storage | lb | 86,000 |
| Required Storage | gallons | 9,100 |
| LOX Tanks | quantity | 2 |
| Configuration | Horizontal | |
| Tank Size | gallons | 4,000 |
| LOX Footprint | sq ft | 870 |
| BAF Filters | quantity | 2+1 |
| BAF Permeate Flow ⁽¹⁾ | mgd | 17 |
| BAF Footprint | sq ft | 5,000 |
| MF/UF Permeate Flow ⁽²⁾ | mgd | 16 |
| MF/UF Footprint | sq ft | 8,000 |
| RO / UV/AOP Permeate Flow ⁽³⁾ | mgd | 14 |
| RO / UV/AOP Footprint | sq ft | 14,000 |
| Chemical Facility Footprint | sq ft | 6,000 |
| Notes: | | |
| (1) Losses due to BAF are assumed to be minimal | | |
| (2) MF Recovery is assumed at 93% | | |
| (3) RO Recovery is assumed at 85% | | |
| (4) MF and RO recovery rates are consistent with Los Angeles GWR EIR, May 2016 | | |
| (5) Process sizing is based off assumptions in Section 2 and the San Diego PureWater Program which has a similar process train. | | |
| (6) Footprint sizes are estimated based on general process, electrical and instrumentation equipment that would be required. These estimates are conservative and would be further refined during detailed design upon project selection. | | |

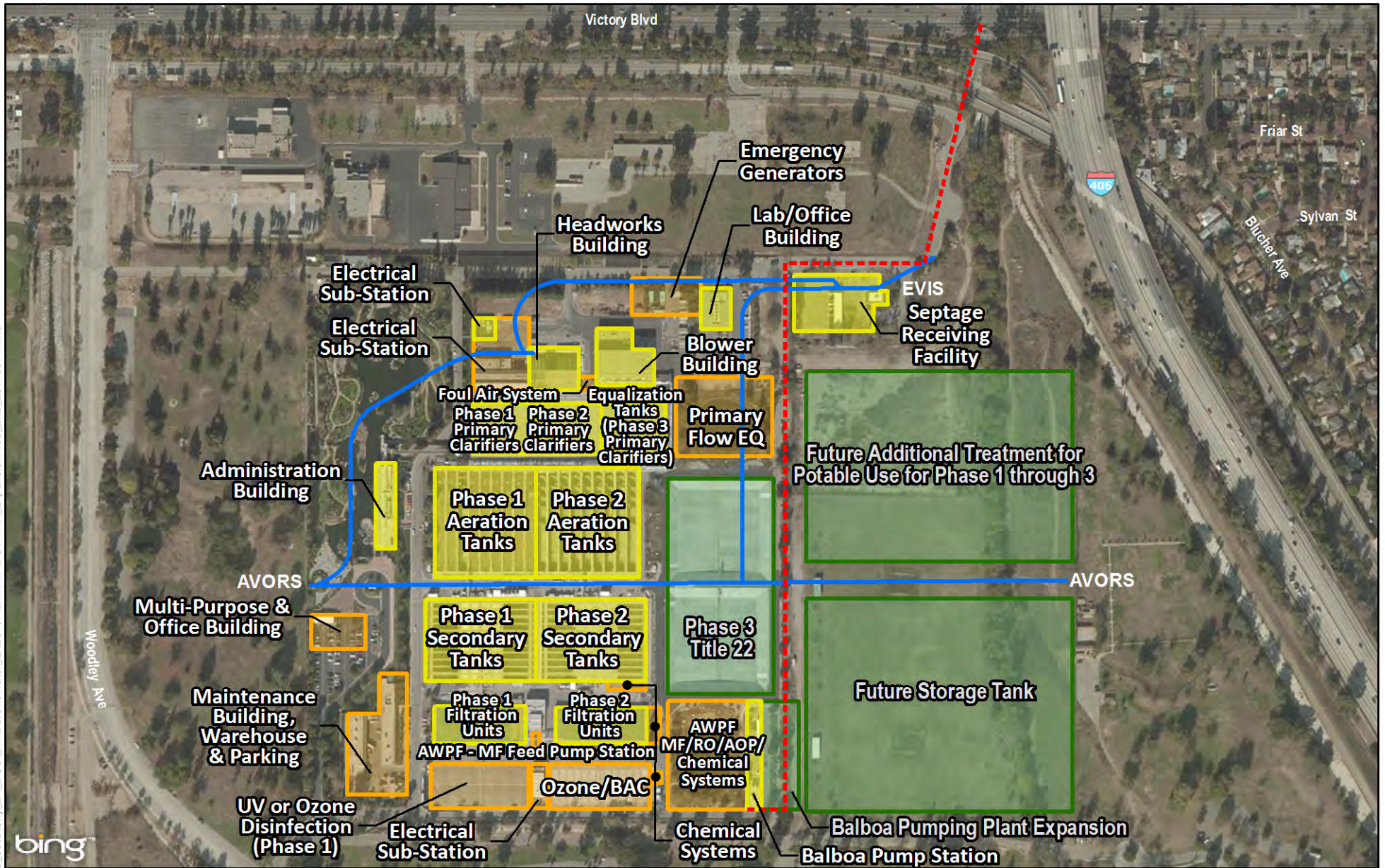

- - - Proposed Brine Line
- AVORS and EVIS
- Existing Facility
- Year 2025 Facility
- Long Term Expansion



Figure D.9
Potential Upgrades for Concept
Option #15
(DCTWRP to LA Aqueduct
Filtration Plant)
 One Water LA 2040 Plan

D.3.5 Concept Option #16 (DCTWRP to LADWP Distribution System)

This concept option utilizes additional treated water through potable reuse with treated water augmentation at DCTWRP. Implementation of this concept option would include an expansion of the GWR AWPf facilities and additional processes that may be required to comply with future potable reuse with treated water augmentation regulations. These processes are unknown as the regulations are in development. This treated water could be conveyed directly into the LADWP distribution system.

This Concept Option is estimated to yield 15,000 AFY (14 mgd) of advanced treated water during normal, wet, and dry years. The expected timeline for the implementation would be between 2030 and 2040. Figure D.10 shows the flow schematic for this concept option and Figure D.11 shows a conceptual level system upgrades map.

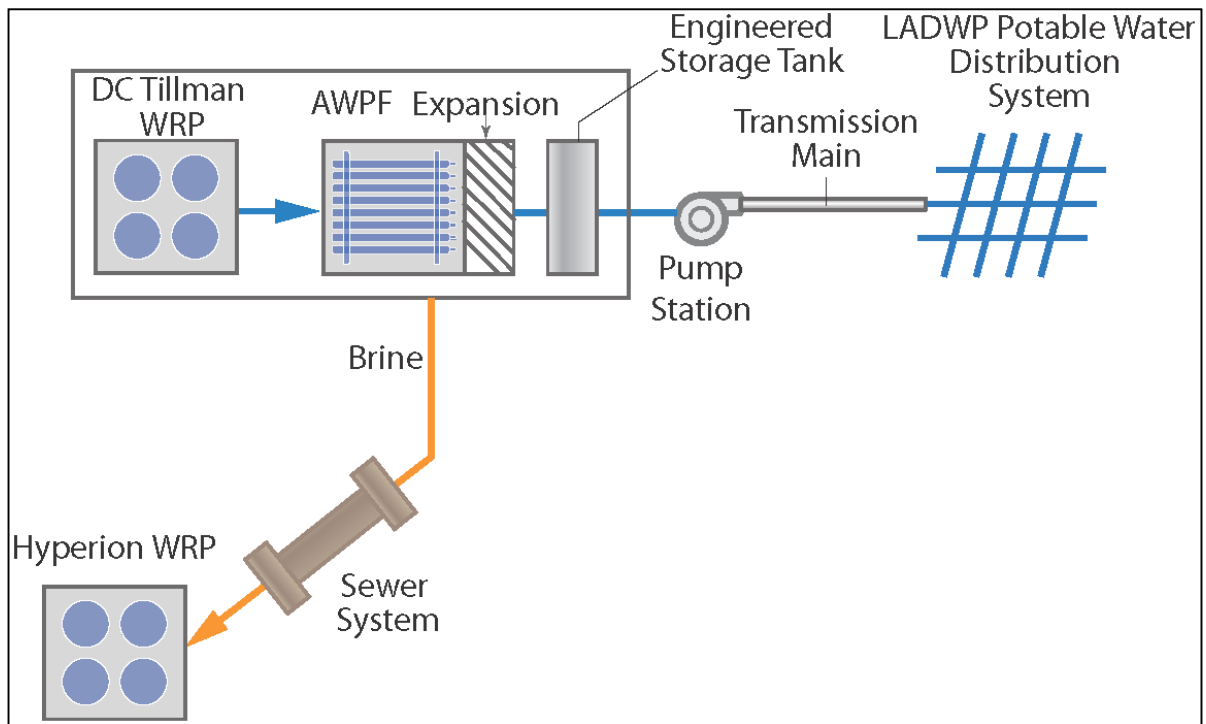
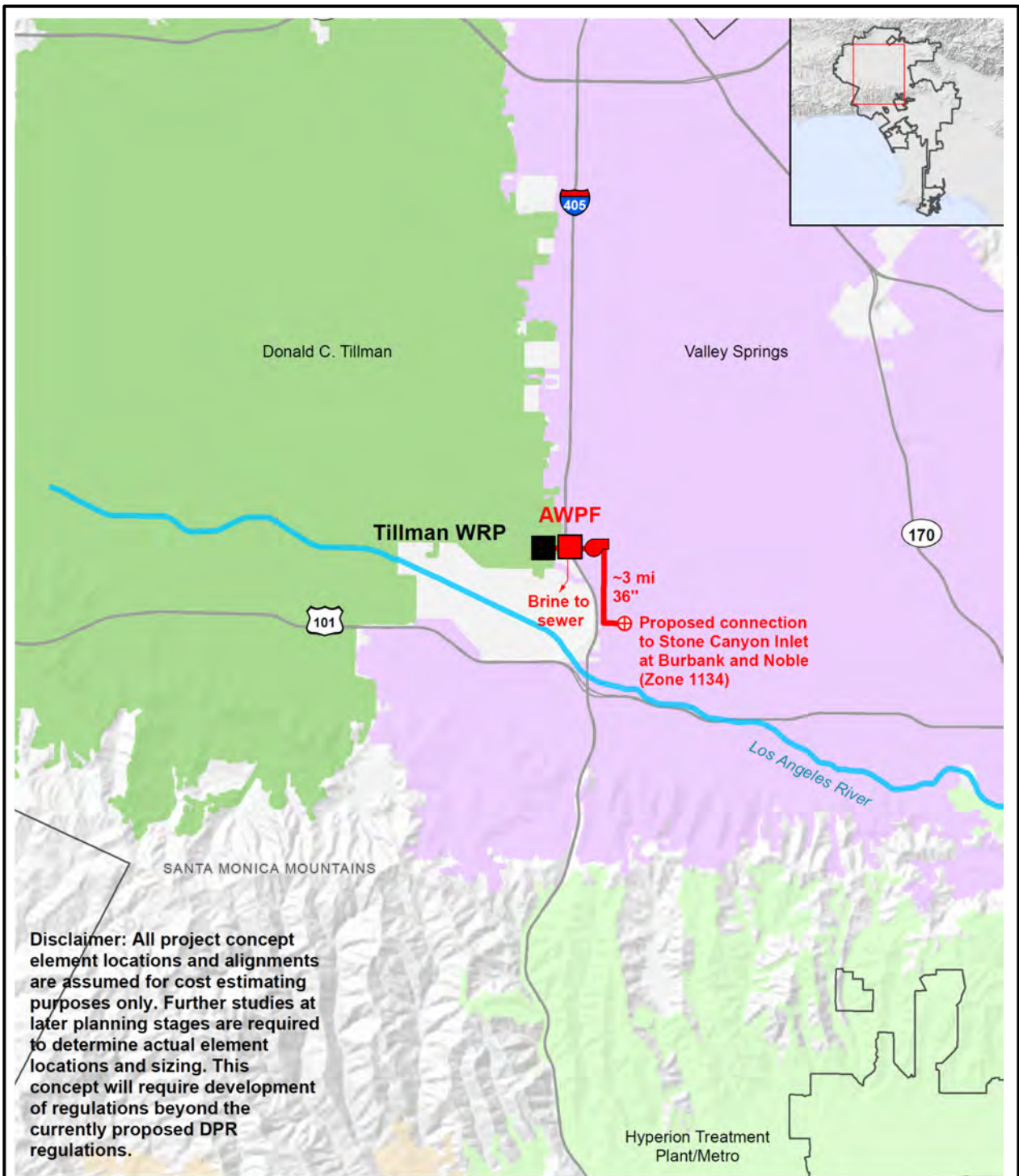
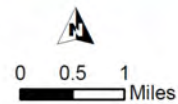

Figure D.10 Process Flow Schematic for Concept Option #16 (DCTWRP to LADWP Distribution System)



Legend

- Existing Water Reclamation Plant (WRP)
- City of Los Angeles
- Sewershed
- Advanced Water Purification Facility (AWPF)
- Pump Station
- Pipeline
- + Connection Point with LADWP system
- Brine



Hillshade Source: CalAtlas
<http://www.atlas.ca.gov>

Figure D.11
System Upgrades for Concept Option #16
(DCTWRP to LADWP Distribution System)
 One Water LA 2040 Plan

D.3.5.1 System Upgrades

Additional system upgrades for this concept option may be needed to convey water from DCTWRP to the LADWP distribution system. These potential upgrades are summarized in Table D.9. This newly constructed pipeline could connect into LADWP's existing distribution system. Figure D.11 shows a system aerial map with the conceptual alignment and location of the pipeline and pump station.

| Table D.9 System Upgrades for Concept Option #16 (DCTWRP to LADWP Distribution System) Wastewater Facilities Plan One Water LA 2040 Plan | |
|---------------------------------------------------------------------------------------------------------------------------------------------------------|---------------------------|
| Description | Quantity |
| Estimated Yield (Wet/Normal/Dry Year) | 15,000 AFY (14 mgd) |
| Pump Station | 1 in quantity, 2,000 hp |
| Pipeline | 3 miles, 36-inch diameter |

D.3.5.2 DCWRP Upgrades

Implementation of this potable reuse with treated water augmentation concept could require an expansion of the GWR AWPf facilities. Similar to other concept options, this concept would yield 14 mgd of purified water for reuse. The AWPf treatment process is expected to be MF or UF, followed by RO, ultraviolet (UV), AOP, and free chlorine contact. Additional processes likely required to comply with future anticipated potable reuse with treated water augmentation regulations would also need to be added. These processes are unknown as the regulations are still in development. A summary of the needed AWPf expansion is found in Table D.10. A 2 MG tertiary effluent equalization tank may also need to be added upstream to the AWPf expansion in order to operate the treatment at a constant flow.

| Table D.10 AWPf Expansion Summary Wastewater Facilities Plan One Water LA 2040 Plan | | | |
|------------------------------------------------------------------------------------------------------------------------------------------------------------------------------------------------------------------------------------------------------|------------------------|--------------------------|-------------------------------|
| Facility | Influent | Estimated Yield | Brine/Solids to DCTWRP |
| GWR AWPf | 45,000 AFY (44 mgd) | 35,000 AFY (31.3 mgd) | 10,000 AFY (9 mgd) |
| AWPf Expansion | 19,000 AFY (17 mgd) | 15,000 AFY (14 mgd) | 4,000 AFY (3 mgd) |
| Note: (1) Per Los Angeles Groundwater Replenishment Project EIR (May 2016), GWR AWPf will yield 35,000 AFY of purified water, of which 5,000 AFY will be used for NPR uses and 30,000 AFY will be used for groundwater replenishment uses. | | | |

A 14 MG engineered storage tank could be needed at DCTWRP to act as a 1 day engineered buffer. Table D.11 discusses a preliminary design criteria resulting in

approximate footprints for the potential upgrades. Potential locations for the DCTWRP upgrades are shown on Figure D.12.

| Table D.11 Potential Upgrades for Concept Option #16 (DCTWRP to LADWP Distribution System) Wastewater Facilities Plan One Water LA 2040 Plan | | |
|-------------------------------------------------------------------------------------------------------------------------------------------------------------------------------------------------------------------------------------------|--------------|-----------------|
| Description | Units | Quantity |
| Tertiary Effluent (Feedwater) | mgd | 17 |
| Ozone Dose | mg/L | 10 |
| Generator Size | lbs/day | 730 |
| Generator Number | | 2+1 |
| Generator Footprint | sq ft | 2,700 |
| Ozone Contactor | Serpentine | |
| Number | | 2+1 |
| Ozone Contactor Footprint | sq ft | 2,700 |
| O ₃ gas concentration | % | 12 |
| Days of Storage | days | 7 |
| Required Storage | lb | 86,000 |
| Required Storage | gallons | 9,100 |
| LOX Tanks | quantity | 2 |
| Configuration | Horizontal | |
| Tank Size | gallons | 4,000 |
| LOX Footprint | sq ft | 870 |
| BAF Filters | quantity | 2+1 |
| BAF Permeate Flow ⁽¹⁾ | mgd | 17 |
| BAF Footprint | sq ft | 5,000 |
| MF/UF Permeate Flow ⁽²⁾ | mgd | 16 |
| MF/UF Footprint | sq ft | 8,000 |
| RO / UV/AOP Permeate Flow ⁽³⁾ | mgd | 14 |
| RO / UV/AOP Footprint | sq ft | 14,000 |
| Product Water Storage | MG | 14.0 |
| Product Water Storage Footprint | sq ft | 42,000 |
| Product Water Storage Hydraulic Retention Time | hr | 24 |
| Chemical Facility Footprint | sq ft | 6,000 |
| Notes: | | |
| (1) Losses due to BAF are assumed to be minimal | | |
| (2) MF Recovery is assumed at 93% | | |
| (3) RO Recovery is assumed at 85% | | |
| (4) MF and RO recovery rates are consistent with Los Angeles GWR EIR, May 2016 | | |
| (5) Process sizing is based off assumptions in Section 2 and the San Diego PureWater Program which has a similar process train. | | |
| (6) Footprint sizes are estimated based on general process, electrical and instrumentation equipment that would be required. These estimates are conservative and would be further refined during detailed design upon project selection. | | |

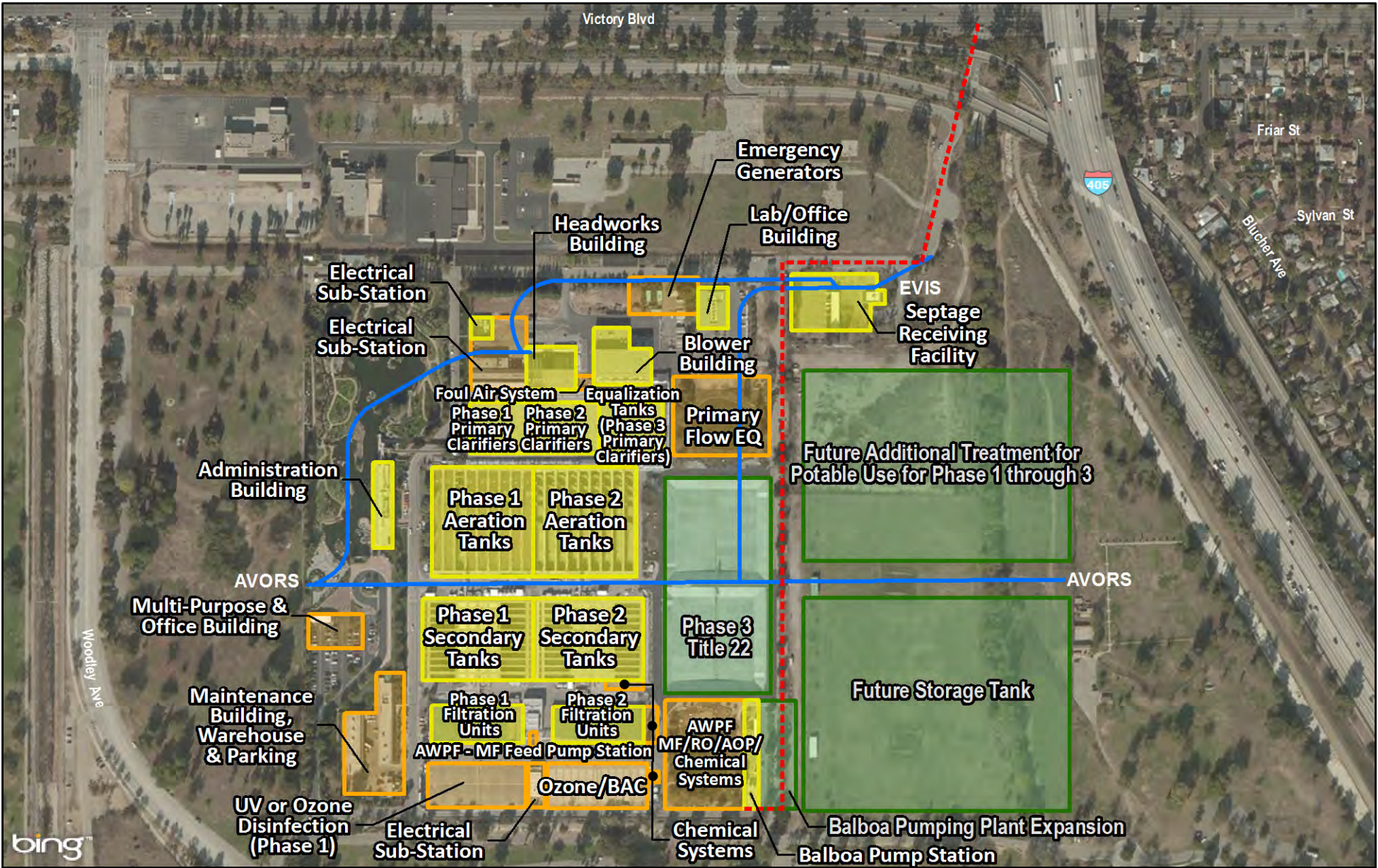

- - - Proposed Brine Line
- AVORS and EVIS
- Existing Facility
- Year 2025 Facility
- Long Term Expansion



Figure D.12
Potential Upgrades for Concept
Option #16
(DCTWRP to LADWP
Distribution System)
 One Water LA 2040 Plan

D.3.6 Concept Option #22 (East-West Valley Interceptor Sewer)

Concept Option #22 (EWVIS) would consist of a series of lift stations and a force main that would convey flows to DCTWRP. The force main would need to vary in diameter from 24 to 42 inches, totaling 6 miles in length. The force main would require a total of 6 lift stations. Figure D.13 shows the flow schematic for EWVIS, depicting the sewer pipelines that would no longer convey flow to DCTWRP.

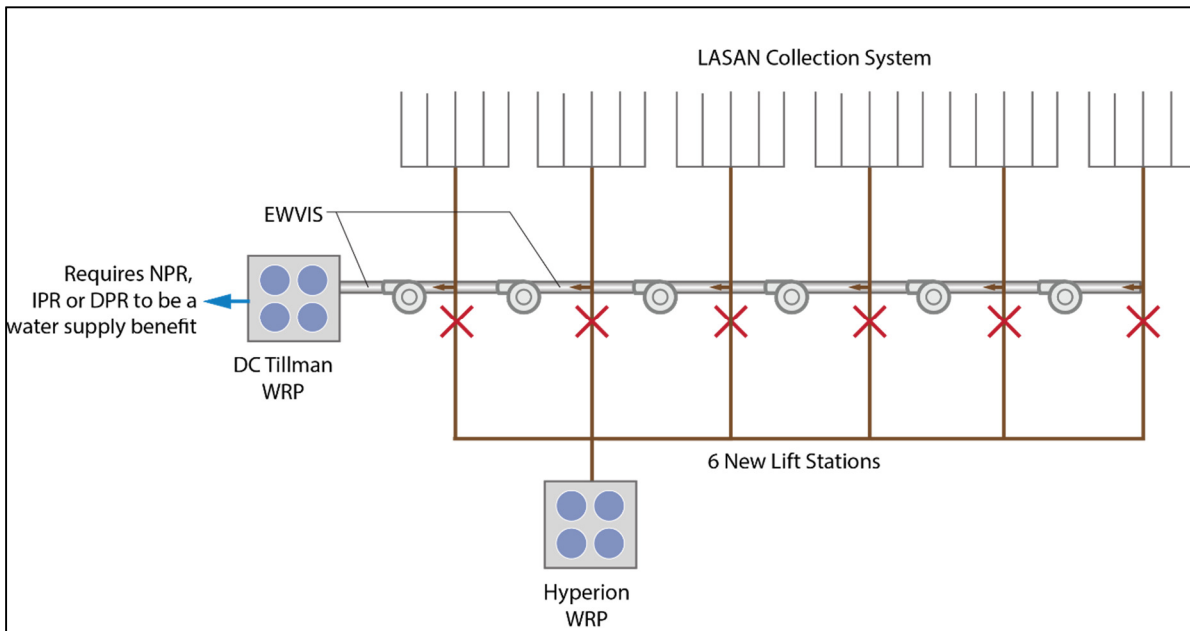

Figure D.13 Process Flow Schematic for Concept Option #22 (EWVIS)

D.3.6.1 System Upgrades

Implementation of this project would primarily involves lift stations, diversion structures, and varying pipelines. Conveyance upgrades could consist of 6 miles of force main pipelines, varying in diameter from 24-inch to 42-inch. Six diversion structures and sewer bypass would likely be needed to divert flows into the new sewer line. Additionally, six new lift stations would be needed to pump the water to DCTWRP. Table D.12 provides a summary of the estimated yield in addition to system upgrades. Figure D.14 shows the system aerial map for this concept option.

| Table D.12 System Upgrades for Concept Option #22 (EWWIS) Wastewater Facilities Plan One Water LA 2040 Plan | |
|----------------------------------------------------------------------------------------------------------------------------|------------------------------|
| Description | Quantity |
| Estimated Yield (Normal/Wet/Dry Year) | 12,800 AFY (11.4 mgd) |
| Force Main | 6 miles, 24-42 inch diameter |
| Diversion Structure | 6 in quantity |
| Lift Station | 6 in quantity |
| Flow Velocity (at peak dry weather) | 5 to 7.5 fps |
| Minimum Flow Velocity | 3 fps |
| Maximum Flow Velocity | 10 fps |

D.3.6.2 DCTWRP Upgrades

EWWIS would provide sufficient flows to operate Phase 1 and 2 of DCTWRP at the current plant capacity of 80 mgd. The AWPf designed for the GWR Project would be sufficient to handle the diverted flows from EWWIS. Hence, no potential upgrades for DCTWRP would be needed for implementation of this concept option.

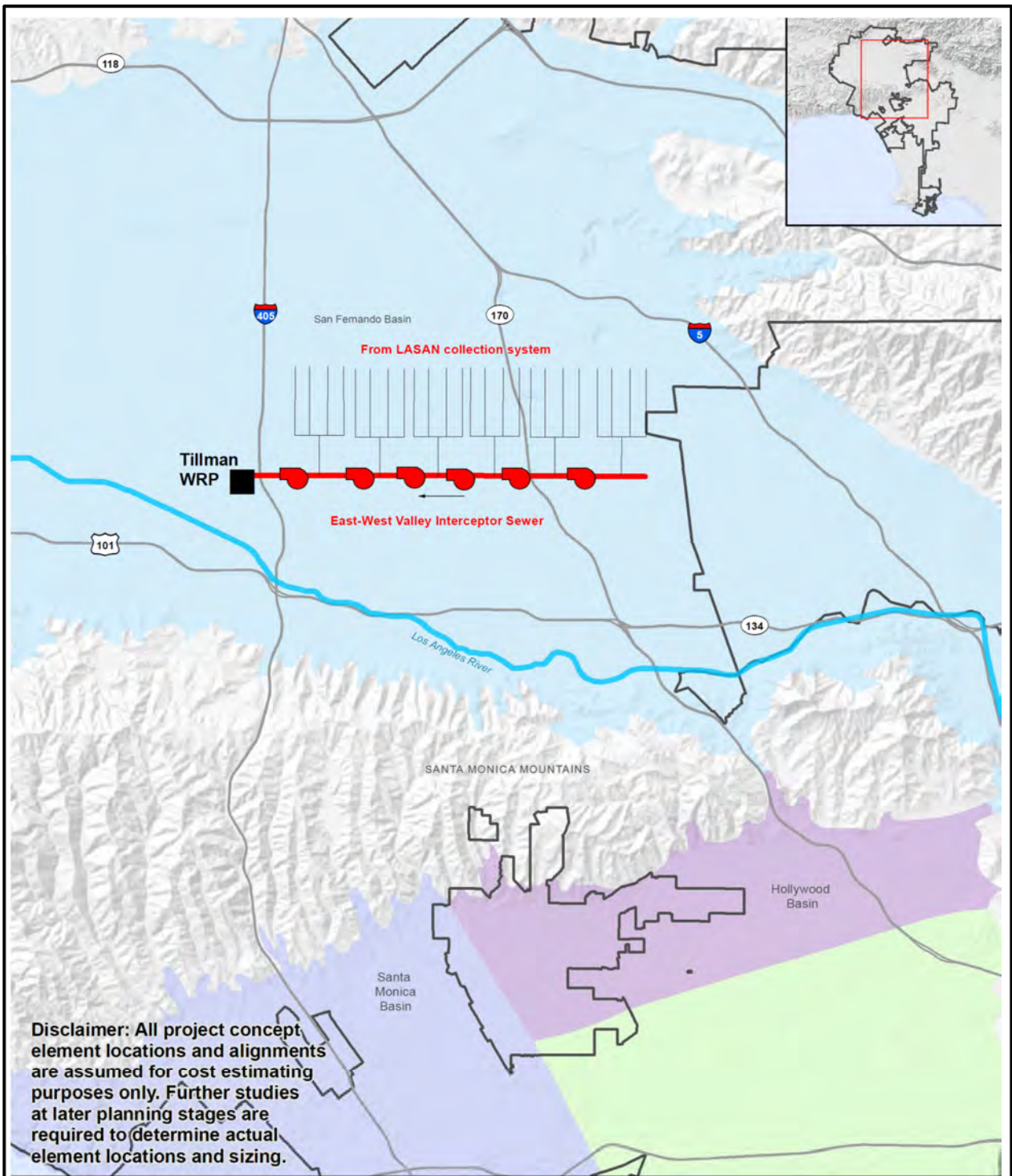

Legend

- Existing Water Reclamation Plant (WRP)
- City of Los Angeles
- Sewershed
- Flow direction
- Collection system
- Lift Station
- Sewer

 0 0.5 1
 Miles
Hillshade Source: CalAtlas
<http://www.atlas.ca.gov>

Figure D.14
System Upgrades for Concept #22
(EWVIS)
 One Water LA 2040 Plan

D.3.7 Concept Option #26 (Japanese Garden & Sepulveda Basin Lakes Recirculation)

Lake Balboa, the Japanese Garden, and Wildlife Lake utilize approximately 25,000 AFY of recycled water from DCTWRP. Currently, after flowing through the gardens and lakes, the water is released to the Los Angeles River. A portion of this water could be returned to DCTWRP for retreatment and reuse. Implementation of this concept option could result in an up to an additional 20,000 AFY (18 mgd) available for reuse. Figure D.15 shows a process concept flow schematic for this concept option.

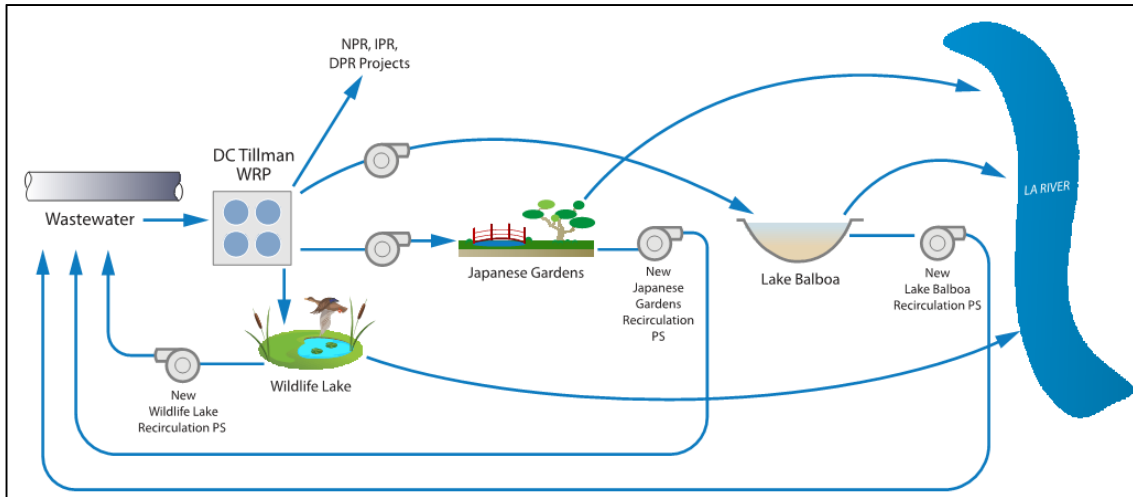

Figure D.15 Process Flow Schematic for Concept Option #26 (Japanese Garden & Sepulveda Basin Lake Recirculation)

D.3.7.1 System Upgrades

Implementation of this project would primarily involve pump stations and varying pipelines. Conveyance upgrades could consist of 3 new pump stations, from Lake Balboa, Japanese Gardens, and Wildlife Lake to the headworks of DCTWRP. Additionally, two miles of new pipelines may be needed. Table D.12 provides a summary of the estimated yield in addition to system upgrades. Figure D.16 shows the potential system upgrades map for this concept option.

| Table D.13 System Upgrades for Concept Option #26 (Japanese Garden & Sepulveda Basin Lake Recirculation) Wastewater Facilities Plan One Water LA 2040 Plan | |
|-------------------------------------------------------------------------------------------------------------------------------------------------------------------------------|---------------------|
| Description | Quantity |
| Estimated Yield (Normal/Wet/Dry Year) | 20,000 AFY (18 mgd) |
| Pump Station | 3 in quantity |
| Pipeline | 2 miles in length |

D.3.7.2 DCTWRP Upgrades

Japanese Garden and Sepulveda Basin lake recirculation could provide additional flows at DCTWRP for reuse. Implementation of this concept option would likely not require upgrades at DCTWRP.

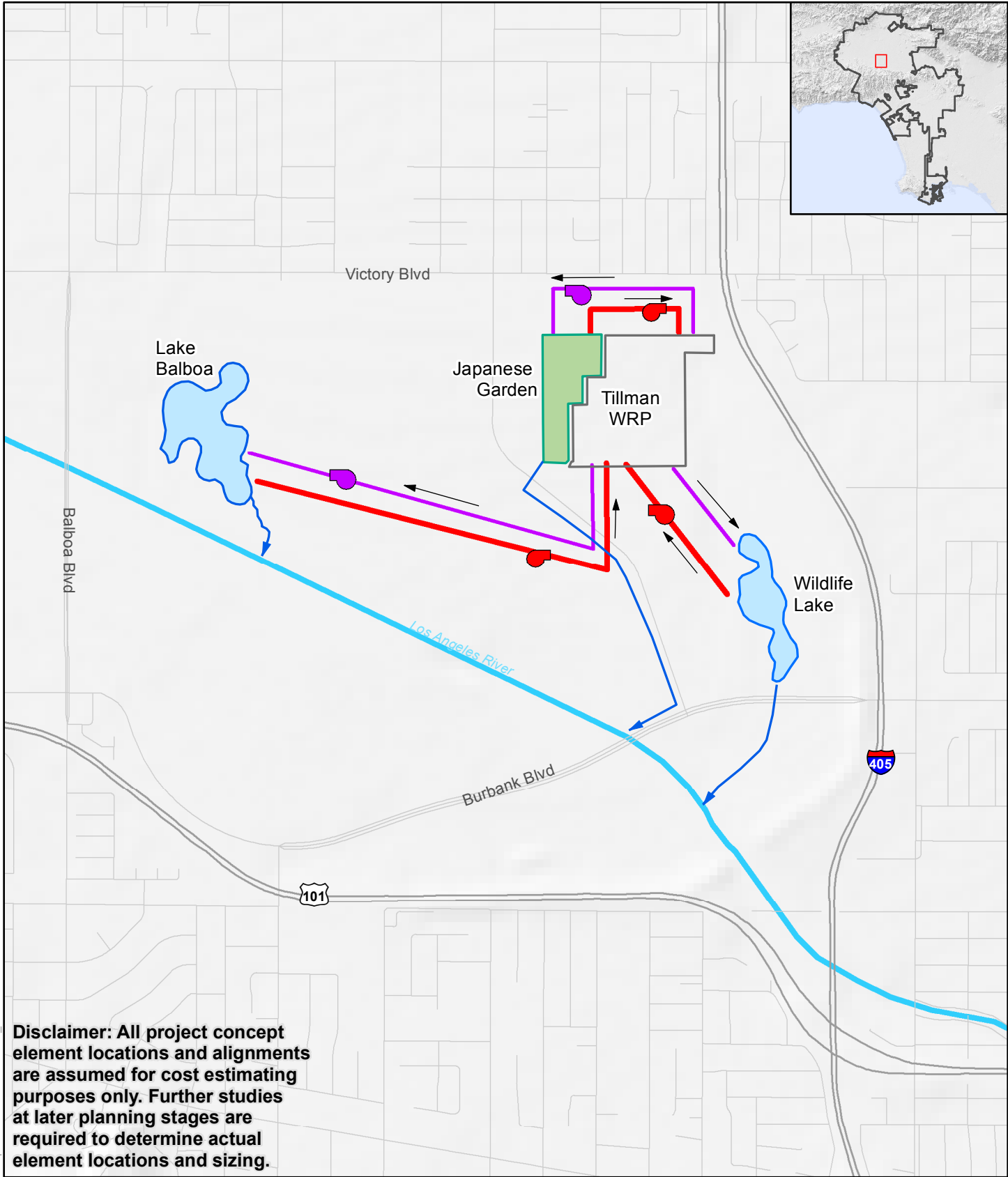

Legend

- Flow direction
- Discharge direction
- Proposed Pump Station
- Existing Pump Station
- Proposed Pipeline
- Existing Recycled Water Pipeline



Hillshade Source: CalAtlas
<http://www.atlas.ca.gov>

Figure D.16
System Upgrades for
Concept Option #26
(Japanese Garden &
Sepulveda Basin Lakes
Recirculation)
 One Water LA 2040 Plan

-This Page Left Blank Intentionally-

LOS ANGELES-GLENDALE WATER RECLAMATION PLANT CONCEPT OPTIONS

This appendix provides information pertaining to the implementation of those Concept Options developed specifically for LAGWRP. Chapter 6 – Los Angeles-Glendale Water Reclamation Plant includes an overview of the approach to the development and prioritization of Concept Options. Additionally, the preferred, or selected, approach to optimize reuse from this facility is repeated.

E.1 BACKGROUND

The preliminary list of concept options that support a locally sourced water supply was developed through workshops that solicited ideas and input from a workgroup as well as community stakeholders. This workgroup included contributors from an array of communities, LASAN, LADWP, other City Bureaus and Departments and select technical advisors. These ideas resulted in the development of concept options within the 2040 planning horizon. Concept options represent new concepts that have not been previously evaluated by the City.

With this methodology, a list of 27 concept options was developed for the entire system. Of these 27 concept options, two concept options were identified for LAGWRP. Determination of LAGWRP's future system needs were based on previous master plans, planning documents, discussions with City staff, and brainstorming sessions. The concept options are preliminary in nature and is not a commitment to level or quantity of treatment.

E.2 LAGWRP CONCEPT OPTIONS

Table E.1 lists the concept options associated with LAGWRP, including the normal year estimated yield and associated capital costs.

| Table E.1 LAGWRP Concept Options Wastewater Facilities Plan One Water LA 2040 Plan | | | | | |
|---------------------------------------------------------------------------------------------------|-------------------------------------|-----------------------------------------------------|--------------------------------------------------|-------------------------------------------------|----------------------------------|
| Concept Option # | Title | Strategy | Estimated Yield (Normal Year) | Capital Cost (\$M)⁽¹⁾ | Unit Cost (\$/AF) |
| 17 | LAGWRP to Headworks Reservoir | Potable Reuse with Treated Water Augmentation | 6,000 AFY (5 mgd) | \$140 | \$1,500 |

| Table E.1 LAGWRP Concept Options Wastewater Facilities Plan One Water LA 2040 Plan | | | | | |
|--------------------------------------------------------------------------------------------------------------------------------------------------------------------------------------------------------------------------------------------------------------------------------|-------------------------------------------------|-------------------|--------------------------------------|-----------------------------------------|--------------------------|
| Concept Option # | Title | Strategy | Estimated Yield (Normal Year) | Capital Cost (\$M)⁽¹⁾ | Unit Cost (\$/AF) |
| 23 | Increase Recycled Water Demand beyond 2015 UWMP | Non-Potable Reuse | 3,500 AFY (3 mgd) | \$70 ⁽²⁾ | \$2,100 |
| Note: | | | | | |
| (1) Total Concept Option cost includes a variety of project components including treatment facilities, conveyance, and injection and extraction facilities. Not all costs pertain to the Wastewater Facilities Plan. | | | | | |
| (2) This capital cost reflects the proportion of costs specifically for LAGWRP to implement Concept Option #23 (Increase Recycled Water Demand beyond 2015 UWMP). The cost was calculated using proportions of yield and cost relative to overall concept implementation cost. | | | | | |
| (3) Bold indicates a Priority A Concept Option | | | | | |

As shown in Table E.1 the Concept Options for LAGWRP involve either:

- Potable reuse with treated water augmentation - Projects that would deliver advanced treated recycled water (purified water) directly to a potable water system.
- Non-Potable Reuse

E.3 SUMMARY OF THE PREFERRED APPROACH

As part of the WWFP development, each of the concept options listed above was reviewed to identify improvements that would need to be implemented at the plant as well as system changes to convey that product water. This analysis included preliminary sizing of treatment process modifications, location of the processes, and preliminary cost estimates. Based on the overall concept score, cost estimates, and portfolio evaluation results, the concept options were prioritized. The concept options for LAGWRP were prioritized as follows:

- Priority A: Concept Option #17 - Potable Reuse with treated water augmentation from LAGWRP to the City's distribution system via Headworks Reservoir
- Priority B: Concept Option #23 - Non-Potable Reuse expansion from LAGWRP

Only Concept Option #17 would involve the installation of additional treatment facilities at LAGWRP to deliver advanced treated water for potable reuse to the City's distribution system via temporary storage and monitoring in Headworks Reservoir.

As shown on Figure E.1, the most critical trigger of highest ranked potable reuse opportunity (Concept Option #17 - LAGWRP to Headworks Reservoir) is adopting potable reuse with treated water augmentation regulations that would allow this type of water reuse practice.

If potable regulations are not accepted within a desired timeframe or if the City prefers a more conventional form of water reuse, the Priority B Concept Option #23 (NPR expansion beyond 2015 UWMP) could be considered for the remaining available flows. The most critical trigger for this option is new customer demand that is cost-effective to serve, considering the customer's location, demand size, demand variability, and water quality requirements. In case neither the potable reuse regulations nor any new recycled water customers that can be feasibly served materialize, it is recommended to postpone any new water reuse projects from LAGWRP. This decision is indicated as "No Change" on Figure E.1.

However, triggers, underlying conditions, and assumptions made for the development of these concept options are likely to change in the future. It is therefore recommended that City staff closely monitor all triggers and other circumstances that may impact the viability and prioritization of all concept options developed for LAGWRP. Future changed conditions may not only change the prioritization of the concept options included as Priority A and B, but also impact the viability of the four other potable reuse options from LAGWRP that have not yet been identified in this plan.

E.4 CONCEPT OPTION IMPLEMENTATION

Each of the two LAGWRP concept options is discussed in the following subsection. Included are:

- General narrative description of Concept Option
- Concept schematic
- System requirements for improvement needed to implement
- Location map depicting LAGWRP and end use
- Outline of required upgrades to LAGWRP to accommodate option
- Site plan of LAGWRP highlighting areas impacted

The information provided pertains to the selected option as well as those not selected.

LA-Glendale Water Reclamation Plant

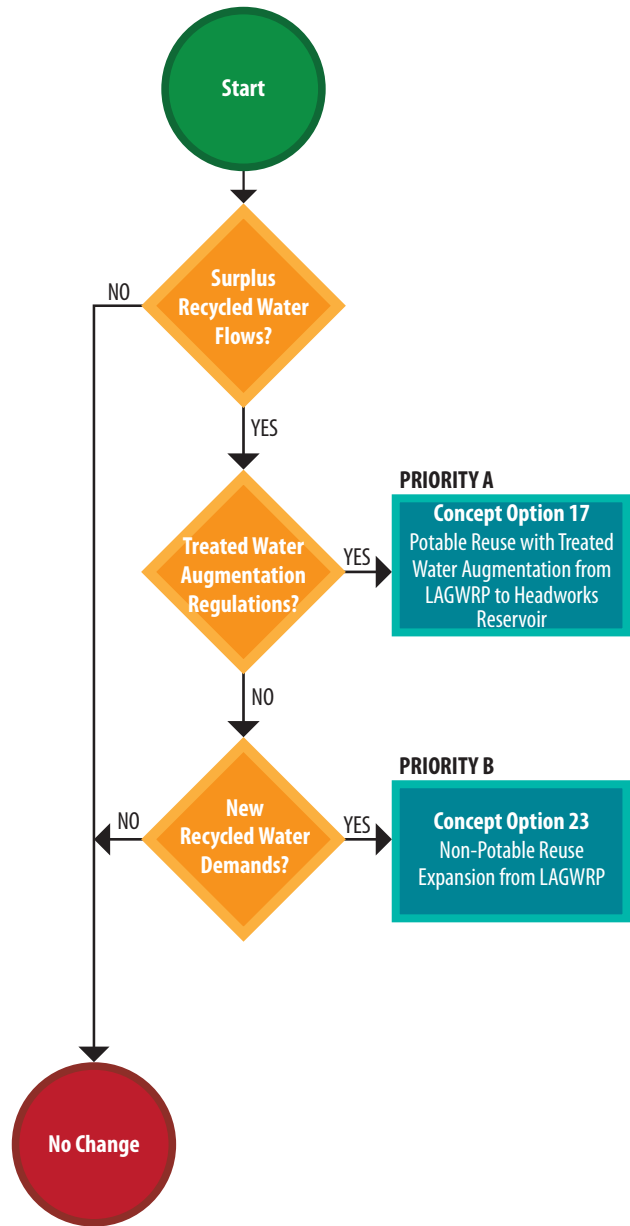

LEGEND & ACRONYMS

- ◆ Trigger
- Concept Option
- Flow Management Option

| | |
|--------|-----------------------------------------------------|
| DCTWRP | Donald C. Tillman Water Reclamation Plant |
| GWR | Groundwater Replenishment Project |
| HWRP | Hyperion Water Reclamation Plant |
| LAGWRP | LA-Glendale Water Reclamation Plant |
| RWQCB | Regional Water Quality Control Board |
| TIWRP | Terminal Island Water Reclamation Plant |
| WRD | Water Replenishment District of Southern California |

Disclaimer: At each trigger (decision point), evaluate all triggers and concept option priorities to consider changed circumstances in the future.

Figure E.1
Trigger-Based Implementation
Strategy for LAGWRP
One Water LA 2040 Plan
Summary Report

E.4.1 Concept Option #17 (LAGWRP to Headworks Reservoir)

This concept option is estimated to yield 6,000 AFY (5 mgd) of advanced treated water during normal, wet, and dry years. This estimated yield is based on the average remaining flow available for further treatment after NPR demand is met. The expected timeline for the implementation of this concept is 2035-2040. Figure E.2 shows a process concept flow schematic and a system map is shown on Figure E.3.

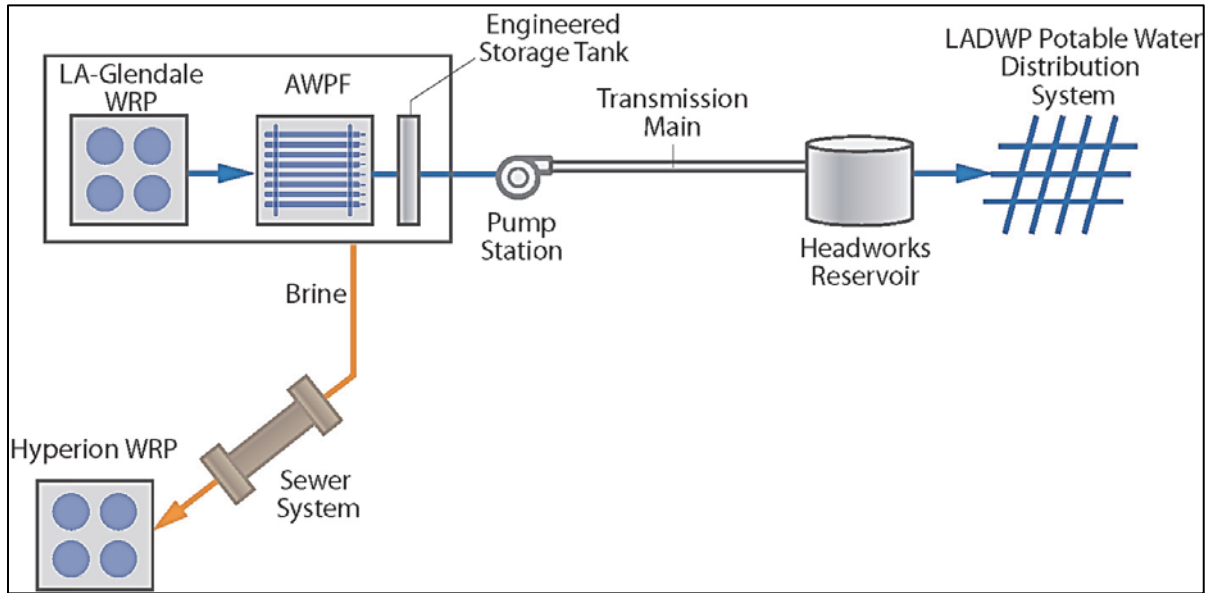
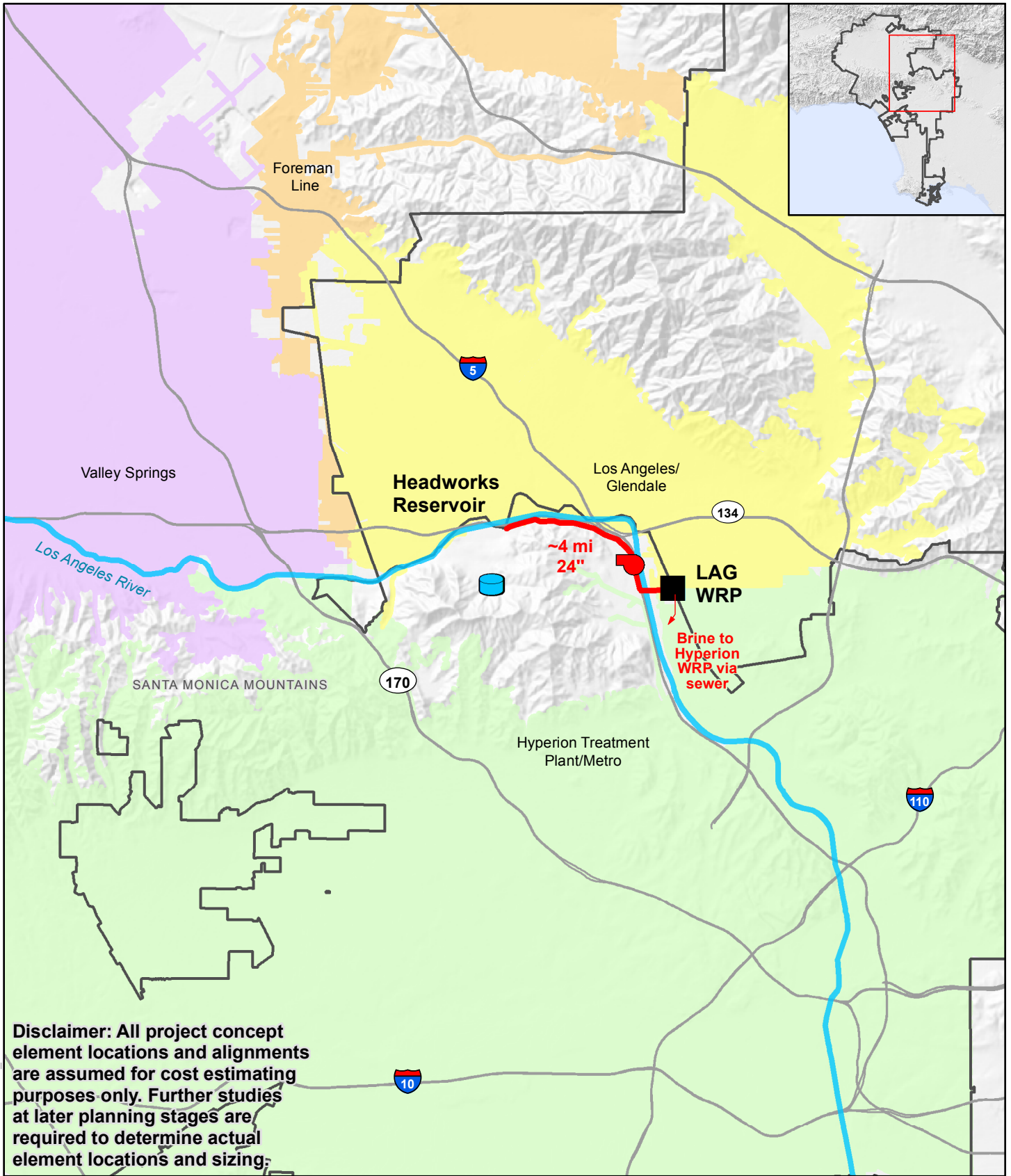

Figure E.2 Process Schematic for Concept Option #17 (LAGWRP to Headworks Reservoir)

E.4.1.1 System Upgrades

To deliver the water from LAGWRP to the Headworks Reservoir, four miles of 24-inch diameter transmission pipeline may be required (see Table E.2). Pipeline construction would have to cross under the I-5 in the vicinity of Griffith Park and may lead to construction challenges. This pipeline would be connected to a new, 200 hp pump station located at LAGWRP.

| Table E.2 System Upgrades for Concept Option #17 (LAGWRP to Headworks Reservoir) Wastewater Facilities Plan One Water LA 2040 Plan | |
|---------------------------------------------------------------------------------------------------------------------------------------------------------------|----------------------------------|
| Description | Quantity |
| Estimated Yield (Normal/Wet/Dry Year) | 6,000 AFY (5 mgd) ⁽¹⁾ |
| Conveyance Pipeline | 4 miles of 24-inch diameter |
| Pump Station | 200 hp |
| Note: (1) City of Glendale co-owns LAGWRP, Glendale is entitled to 50% of the flows | |



Disclaimer: All project concept element locations and alignments are assumed for cost estimating purposes only. Further studies at later planning stages are required to determine actual element locations and sizing.

Legend

- Existing Water Reclamation Plant (WRP)
- Existing Reservoir
- Pump Station
- Pipeline
- Brine
- City of Los Angeles
- Sewershed



Hillshade Source: CalAtlas
<http://www.atlas.ca.gov>

Figure E.3
System Upgrades for
Concept Option #17
(LAGWRP to Headworks Reservoir)
 One Water LA 2040 Plan

E.4.1.2 LAGWRP Upgrades

This project could require a new AWPf to be constructed at LAGWRP that could meet the average yield of 5 mgd. Flows not required to meet current NPR demands would be diverted to the AWPf. The AWPf would treat the recycled water to match Division of Drinking Water (DDW) potable reuse treated water augmentation requirements at the time of project implementation, which is assumed to consist of biologically active filters (O₃/BAF), UF, RO, and UV/AOP. The AWPf would be sized to accept an inflow of up to 8 mgd with a 20 percent assumed brine loss. A 1 MG engineered storage tank may also be required to provide 3 hours of detention time. Brine disposal could be diverted to the plant waste drain and conveyed to HWRP.

A new pump station could also be constructed to convey the product AWPf water to the Headworks Reservoir. The pump station is sized to meet the demands of the AWPf and could be co-located with the AWPf. A conceptual site layout for a 5 mgd AWPf, storage tank and pump station are shown on Figure E.4. The final location of these upgrades would be determined during detailed design should this concept option be selected for implementation. Preliminary design criteria yielding an approximate required footprint is shown in Table E.4.

| Table E.4 Conceptual Site Layout Footprint & Design Criteria Assumptions for Concept Option # 17 (LAGWRP to Headworks Reservoir)⁽¹⁾ Wastewater Facilities Plan One Water LA 2040 Plan | | |
|-------------------------------------------------------------------------------------------------------------------------------------------------------------------------------------------------------------|-----------------|--------------|
| Description | Quantity | Units |
| Tertiary Effluent (Feedwater) | 8 | mgd |
| Ozone Dose | 10 | mg/L |
| Generator Size | 330 | lbs/day |
| Generator Number | 2+1 | |
| Generator Footprint | 1,200 | sq ft |
| Ozone Contactor | Serpentine | |
| Number | 2+1 | |
| Ozone Contactor Footprint | 1,200 | sq ft |
| Ozone gas concentration | 12 | % |
| Days of Storage | 7 | days |
| Required Storage | 39,000 | lb |
| Required Storage | 4,100 | gallons |
| LOX Tanks | 2 | quantity |
| Configuration | Horizontal | |
| Tank Size | 4,000 | gallons |
| LOX Footprint | 400 | sq ft |
| BAF Filters | 2+1 | quantity |

| Table E.4 Conceptual Site Layout Footprint & Design Criteria Assumptions for Concept Option # 17 (LAGWRP to Headworks Reservoir)⁽¹⁾ Wastewater Facilities Plan One Water LA 2040 Plan | | |
|-------------------------------------------------------------------------------------------------------------------------------------------------------------------------------------------------------------------------------------------|-----------------|--------------|
| Description | Quantity | Units |
| BAF Permeate Flow ⁽²⁾ | 7.9 | mgd |
| BAF Footprint | 3,000 | sq ft |
| MF/UF Permeate Flow ⁽³⁾ | 7.50 | mgd |
| MF/UF Footprint | 3,800 | sq ft |
| RO / UV/AOP Permeate Flow ⁽⁴⁾ | 6 | mgd |
| RO / UV/AOP Footprint | 6,000 | sq ft |
| Brine Flow | 1.5 | mgd |
| Chemical Facility Footprint | 6,000 | sq ft |
| Product Water Storage | 1.0 | MG |
| Product Water Storage Footprint | 3,000 | sq ft |
| Product Water Storage Hydraulic Retention Time | 3.0 | hr. |
| Pump Station | 200 | hp |
| Pump Station Footprint | 1,000 | sq ft |
| Assumptions: | | |
| (1) Process sizing is based off assumptions in TM 5.2 and the San Diego PureWater Program which has a similar process train. | | |
| (2) BAF Recovery is assumed at 99% | | |
| (3) MF Recovery is assumed at 95% | | |
| (4) RO Recovery is assumed at 80% | | |
| (5) Footprint sizes are estimated based on general process, electrical and instrumentation equipment that would be required. These estimates are conservative and would be further refined during detailed design upon project selection. | | |



- Primary Effluent Equalization Storage Project
- Potential AWWP Location

Figure E.4
Potential Process Location for
Concept Option #17
(LAGWRP to Headworks Reservoir)
 One Water LA 2040 Plan

E.4.2 Concept Option #23 (Increase Recycled Water Demand beyond 2015 UWMP)

LAGWRP can supply up to 9 mgd of tertiary disinfected recycled water through partnerships with LADWP and the City of Glendale's Public Service Department to distribute the recycled water. There are currently over forty customers that use approximately 4.3 mgd of LAGWRP's recycled water. However, recycled water customers have been conceptually identified through 2040 to account for an additional demand of approximately 3,500 AFY (3.0 mgd) from LAGWRP in the Metro area. This project would only be implemented once the increased recycled water demand customers have been confirmed. The supporting infrastructure to support this demand would consist of additional recycled water pipelines.

E.4.2.1 System Upgrades

LAGWRP currently pumps tertiary disinfected recycled water from the on-site recycled water pump wet through a 30 inch force main to a 2 MG storage tank in Griffith Park. The LADWP operated and maintains the recycled water station and storage tank. To deliver the additional recycled water from LAGWRP to the identified Metro customers, the existing pump station and storage tank would remain as-is and approximately 18.7 miles of new conveyance pipeline could be required (see Table E.5). Figure E.5 depicts a process concept flow schematic for this concept. A system aerial map is shown on Figure E.6.

| Table E.5 System Upgrades for Concept Option #23 (Increase Recycled Water Demand beyond 2015 UWMP) Wastewater Facilities Plan One Water LA 2040 Plan | |
|---------------------------------------------------------------------------------------------------------------------------------------------------------------------|--------------------------------------------------------------------------------------------------------------------------------|
| Description | Quantity |
| Estimated Yield (Normal/Wet/Dry Year) | 3,485 AFY (3.1 mgd) |
| Conveyance Pipeline | 6.6 miles of 6-inch diameter 2.5 miles of 8-inch diameter 4.1 miles of 12-inch diameter 5.5 miles of 16-inch diameter |

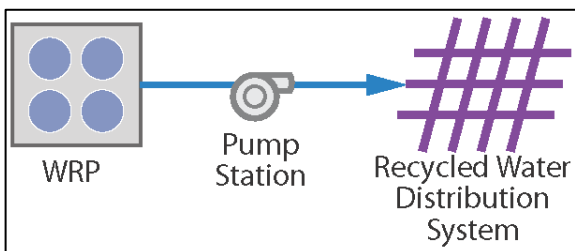
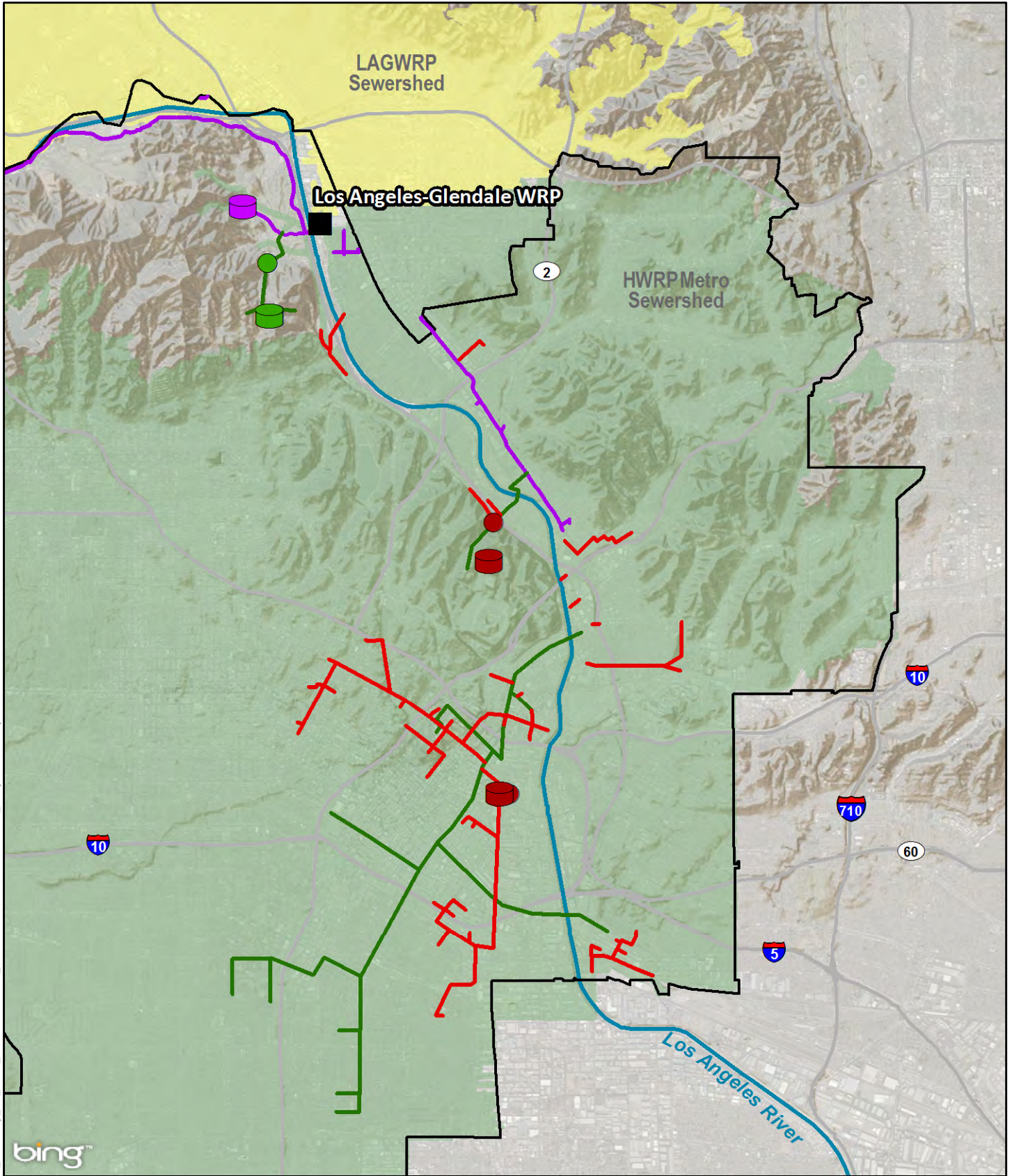

Figure E.5 Process Flow Schematic Concept Option #23 (Increase RW Demand beyond UWMP)



Document Path: \\usinv1s011g1\GIS\Jobs\City_LA_BOS\MXDs\OneWater_LA2040Plan\General\LAGWRP_RecycledWater\System.mxd











- | | | | |
|-------------------------------------------------------------------------------------|-------------------------------------------------|-------------------------------------------------------------------------------------|---------------|
|  | Existing Water Reclamation Plant (WRP) |  | Existing Tank |
|  | City of LA Boundary |  | Pump Station |
|  | Existing Recycled Water Pipes |  | Tank |
|  | Planned Recycled Water Pipes (2015 UWMP) |  | Pump Station |
|  | Potential Recycled Water Pipes beyond 2015 UWMP |  | Tank |

Figure E.6
System Upgrades Concept Option #23
(Increased Recycled Water Demand
Beyond 2015 UWMP)
 One Water LA 2040 Plan



-This Page Left Blank Intentionally-

BIOSOLIDS DATA

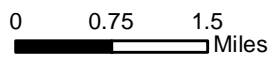
The data in this Appendix includes the yearly biosolids produced at TIWRP and HWRP. This data is used to create the trend figures for the percent total solids, wet tons, and dry tons from 2006 to 2016. The biosolids data presented in Table F.1 shows the yearly average percent total solids, the yearly total wet tons and the yearly total dry tons for TIWRP.

| Table F.1 TIWRP Biosolids Data Wastewater Facilities Plan One Water LA 2040 Plan | | | |
|-------------------------------------------------------------------------------------------------|-------------------------------|-----------------|-----------------|
| Year | % Total Solids | Wet Tons | Dry Tons |
| 2006 | 22.9 | 12,802 | 2,932 |
| 2007 | 21.2 | 12,929 | 2,741 |
| 2008 | 26.5 | 14,203 | 3,764 |
| 2009 | 25.8 | 14,250 | 3,677 |
| 2010 | 25.7 | 14,240 | 3,660 |
| 2011 | 26.0 | 13,435 | 3,493 |
| 2012 | 26.0 | 14,531 | 3,778 |
| 2013 | 26.0 | 13,220 | 3,437 |
| 2014 | 26.0 | 13,806 | 3,590 |
| 2015 | 25.4 | 11,573 | 2,940 |
| 2016 | 23.2 | 12,125 | 2,813 |
| 2017 ⁽¹⁾ | No Cake | 6,104 | N/A |
| <u>Note:</u> 2017 is from January to June. | | | |

The biosolids data presented in Table F.2 shows the yearly average percent total solids, the yearly total wet tons and the yearly total dry tons for HWRP.

| Table F.2 HWRP Biosolids Data Wastewater Facilities Plan One Water LA 2040 Plan | | | |
|------------------------------------------------------------------------------------------------|-------------------------------|-----------------|-----------------|
| Year | % Total Solids | Wet Tons | Dry Tons |
| 2006 | 31.1 | 228,415 | 71,037 |
| 2007 | 30.4 | 228,515 | 69,469 |
| 2008 | 30.4 | 243,943 | 74,159 |
| 2009 | 29.6 | 235,675 | 69,760 |
| 2010 | 29.5 | 229,853 | 67,807 |
| 2011 | 29.0 | 239,430 | 69,435 |
| 2012 | 28.4 | 229,651 | 65,221 |
| 2013 | 28.3 | 233,110 | 65,970 |
| 2014 | 28.2 | 245,834 | 69,325 |
| 2015 | 28.3 | 247,072 | 69,921 |
| 2016 | 25.6 | 265,418 | 67,947 |
| 2017 ⁽¹⁾ | 24.8 | 131,172 | 32,531 |
| Note: 2017 is from January to June. | | | |

The data presented in Tables F.1 and F.2 show numerically how the yearly biosolids mass and concentration at TIWRP has remained steady while the HWRP percent total solids has decreased from 31.1% to 25.6% over the 10-year period.

TECHNICAL SUPPORT MATERIALS

G.1 HYDRAULIC MODELING

The City uses Innovyze's Sewer Flow Estimation Model (SFEM) to accumulate the wastewater contributions along each sewer to estimate average dry-weather flows for current and future conditions. SFEM estimates wastewater flows by tracing the area serviced by each sewer and overlaying population densities to derive the total population serviced by a sewer system. Total residential and employment population is multiplied by average per capita discharge rates of 78 gallons per capita per day (gpcd) for residents and 23 gallons per employee per day (gped) for businesses. Groundwater infiltration (GWI) values determined for the year 2010 as part of the inflow and infiltration (I/I) Reduction Plan (CH2M HILL, 1992) are adopted in SFEM and extrapolated to determine I/I for future years assuming an increase of 0.5 percent per year. Point source flow is based on permit data for industrial waste dischargers and is not adjusted for future years. Typically, industrial discharge is estimated at 90 percent of the permit holder's water usage. These four flow components are then combined to calculate the tributary average dry-weather flow (ADWF) for each sewer pipe, and through downstream accumulation of the calculated values, the ADWF at any point in the sewer system. However, SFEM does not estimate peak flows or flows during wet-weather events, which are some of the design criteria of pumping plants, collections systems, and treatment plants.

The MIKE URBAN (MU) software developed by the Danish Hydraulic Institute, Inc. (DHI) is capable of hydrodynamic modeling of complex sewer collection systems. The development of the hydrodynamic model using MU is the continuation of the static SFEM model. Data from SFEM (i.e, pipe hydraulic network such as pipes, nodes, flow splits diversions, inverted siphons) is imported into the dynamic sewer modeling software. The SFEM data used for static hydraulic analysis is then augmented with more detailed information (e.g. elevations for overflow weir crests, pumping plants, wet wells, special control structures, dry-weather hydrographs, and rainfall hyetographs) to model the dynamic processes in the collection system, such as:

- Diurnal Flow Patterns
- Pumping Plant Operations
- Flow Equalization
- Wet-Weather Events

G.1.1 Dry Weather Model Calibration

The SFEM generated flows were used as inputs during the fabrication of the MU model of the City's primary wastewater system. The calibration process involved modeling of the

SFEM flow inputs in the wastewater network to obtain an agreement between the total daily flow volumes and peak flows between the gauged data and the SFEM loads based on a predefined acceptable error and correlation coefficient. More details of the MU dry weather calibration can be found in the DHI Calibration and Good Modeling Practices Training Manual dated December 5-7, 2007.

The current MU calibrated dry weather model resulted from adjusting the SFEM flow inputs to match the total daily flow volumes for all 849 flow input points throughout the city.

G.1.2 Wet Weather Model Calibration

The wet weather model was calibrated using wet weather flow response. Wet weather flow response is defined in terms of the amount of rainfall necessary to cause a "calibration-suitable event" in the sewer. This is quantified by comparing historical rainfall and sewer response data sets. In a rain event or a series of smaller rainfall events gave rise to an increased in discharge above the dry weather flow (DWF), these events can be characterized as being potentially suitable for calibration. This means that the MU rainfall dependent inflow and infiltration (RDI/I) model parameters can be adjusted to simulate the inflow and infiltration process that produce the wet weather portion of the measured discharge in the collection system.

A "calibration-suitable rain event" is a rainfall event which causes a large enough flow response in the sewer to differentiate the measured flows from normally occurring dry weather flow to such an extent that the parameters in the MU runoff model can be adjusted to show sensitivity.

A total of 110 gauging stations were used to calibrate the MU wet weather model, from January 2008 to March 2009. These stations measured flow depth and velocity on a continual basis using an ultrasonic sensor that transmitted data via a computer modem. The correlation between estimated flow and measured flow was very good for a sewer system of this size and complexity. The gauging stations were placed strategically to measure flows at key sewer locations in the HSA. A comparison of flow estimates and projections to existing design and/or full flow capacities at these locations provided a good sampling of potential hydraulic deficiencies for planning purposes.

G.1.3 10-Year Simulation

In order to have a baseline to evaluate the collection system's response to significant wet-weather events, the City developed a 10-year synthetic design storm. The synthetic design storm is a back-loaded, meaning the greatest accumulation of rainfall occurs in the 3rd or 4th quartile of the storm, hyetograph with a 24-hour cumulative depth and 1-hour peak intensity corresponding to a 10-year recurrence interval for both depth and intensity based on the National Oceanic and Atmospheric Administration's (NOAA) Atlas 14 precipitation frequency estimates. Due to the City's large service area and varying depths and

intensities, the area-weighted average of 4.45 inches and 1.14 inches per hour is used as the 10-year recurrence interval for 24-hour depth and peak 1-hour intensity. The City is currently developing a new 10-year dynamic design storm that would incorporate temporal and spatial characteristics that would simulate how actual storms move through the City service area and at different intensities (e.g. higher depths/intensities at higher elevations.) Development of the dynamic 10-year synthetic storm is scheduled to be completed in late 2017. Table G.1 shows the 10-year synthetic storm hourly intensities and 24-hour cumulative depth.

| Table G.1 10-Year Design Storm Wastewater Facilities Plan One Water LA 2040 Plan | |
|-------------------------------------------------------------------------------------------------|---------------|
| Hour | Inches |
| 1 | 0.05 |
| 2 | 0.05 |
| 3 | 0.05 |
| 4 | 0.06 |
| 5 | 0.06 |
| 6 | 0.06 |
| 7 | 0.06 |
| 8 | 0.07 |
| 9 | 0.07 |
| 10 | 0.07 |
| 11 | 0.08 |
| 12 | 0.08 |
| 13 | 0.12 |
| 14 | 0.13 |
| 15 | 0.14 |
| 16 | 0.15 |
| 17 | 0.16 |
| 18 | 0.17 |
| 19 | 0.25 |
| 20 | 0.28 |
| 21 | 1.14 |
| 22 | 0.48 |
| 23 | 0.34 |

| Table G.1 10-Year Design Storm Wastewater Facilities Plan One Water LA 2040 Plan | |
|-------------------------------------------------------------------------------------------------|---------------|
| Hour | Inches |
| 24 | 0.32 |
| 24-Hour Total | 4.45 |

Using SFEM growth factors, based on the residential, employment, groundwater infiltration, and industrial sources, the 900+ calibration network loads are adjusted respectively to project future flows up to year 2090. The needs of primary pipes (i.e. trunk sewers) and outfalls (i.e. interceptor sewers) is evaluated by modeling the year 2050 dry- and wet-weather flows. For dry-weather, any sewer with a projected depth over diameter (d/D) greater than 0.75 up to year 2050 is considered to be in need of hydraulic relief. Under wet-weather conditions, any sewer with projected overflow using the 10-year synthetic design storm is considered in need of relief.

For design of new facilities or pipes, dry- and wet-weather flows are projected to year 2090. New facilities and pipes are then sized so that the peak dry weather flow (PDWF) d/D is under 0.50 and there is no sewer surcharge under the 10-year design storm.

G.2 RECYCLED WATER IMPLEMENTATION UPDATE

Many of the water reuse concept options at Hyperion WRP would convert a portion of the existing high-purity oxygen activated sludge secondary treatment system to an air-MBR treatment system with nitrification and denitrification. The result will be a higher quality effluent suitable for reuse or for additional, advanced treatment. The origins of this conversion can be found within two previous reuse studies:

- Recycled Water Implementation Strategy Study (2014)
- Hyperion Reuse Feasibility Study (2016)

Both documents concluded that upgrades to the secondary treatment system would enhance reuse opportunities. These documents are included within the attached reference materials. Brief summaries of each are provided in the sections that follow.

G.2.1 Recycle Water Implementation Strategy Study

MWH (now part of Stantec) was retained to prepare the “Recycle Water Implementation Strategy Study” dated April 2014 for LASAN. The focus of the study was to develop and evaluate alternative approaches to providing recycle water to the Los Angeles Harbor area in a cost-effective manner that reduces potable water consumption in that area. The study was also to lay the foundation for a wider strategy of recycling effluent from Hyperion WRP (HWRP) and Terminal Island WRP (TIWRP). Planning included inventorying potential recycled water users/demands, and assessing the impact of current and future reuse

regulations. Conveyance facilities were also investigated to transport recycled water to users.

G.2.1.1 Findings

Alternative approaches to supplying recycled water were formulated based upon location and level of treatment as well as means to distribute. Discrete options were arranged into four groupings.

- Recycled Water Implementation Strategy Study (2014)
- Treat flow at HWRP and send to ECL WRF
- Treat flow at HWRP and send to Harbor Area customers (ECL operations remain)
- Send HWRP Flow to TIWRP for future treatment/distribution (ECL operations remain)
- Use LACSD as an alternative source of wastewater supply (ECL operations remain)

A total of 12 options were formulated. An initial screening of viability reduced the number of options to eight.

The remaining eight options were further evaluated based upon cost and non-cost criteria. Cost assessment was on a total present worth basis. Non-cost criteria included

- Compliance with water use goals
- Environmental Impacts
- Public Policy and Institution Issues
- Flexibility and Adaptability
- Ease of Implementation

All of the top four ranked alternatives were in the groupings of either treat flow at HWRP or use LACSD as a source of wastewater. The top ranked option is the conversion of HWRP to MBR, conveyance to TIWRP, and expansion of the AWPf facilities at TIWRP. An implementation strategy, including schedule and cost, is presented. Discussion of agency and institutional arrangement is also provided.

G.2.1.2 Conditions Update

Since the completion of this study effort, the primary change that may impact the findings is the work underway between the Metropolitan Water District and LACSD to treat and recycle water from the Joint Water Pollution Control Plant (JWPCP). As this partnership moves

forward, the ability to divert flows from JWPCP to the City’s conveyance system may become more challenging.

G.2.2 Hyperion Reuse Feasibility Study

MWH (now part of Stantec) and Carollo Engineers were retained to prepare the “Hyperion Reuse Feasibility Study” dated May 2016 for LASAN. A guiding principle of the study was the vision of full reuse of Hyperion effluent in the future. The study was conducted in two phases. The first developed priorities and goals as well as key constraints. The second phase was focused on the development of alternative reuse scenarios and specific plant improvements required for implementation. The minimum level of treatment in the future for the entire plant was geared around the production of a secondary, nitrified-denitrified (NDN) effluent.

G.2.2.1 Findings

An identified constraint was the impact of diurnal flow variations at HWRP, specifically the occurrence of low flows in late evening/early morning hours. Treatment processes, especially advanced system have limited peaking capacity. The analysis concluded the need for flow equalization in connection with new advanced water treatment (AWT) systems. The greater the flow treated by advanced water purification facility (AWPF), the greater the required volume of flow equalization. Space availability at HWRP is limited with siting of these new facilities challenging.

To achieve a high quality, secondary NDN effluent a number of alternative process schemes were evaluated. The impacts to space and treatment capacity were assessed. Treatment options included:

- Existing high-purity oxygen activated sludge
- Air activated sludge – MLE
- Air activated sludge – MBR
- Air activated sludge – GAS

The preferred approach was the air activated sludge – MBR. Follow-on AWT considered were reverse osmosis (RO) and UV-advanced oxidation processes (AOP). With respect to the first stage conversion, two alternatives were analyzed:

- 70 mgd of NDN secondary effluent – 40 mgd of AWT at HWRP
- 70 mgd of NDN secondary effluent – no AWT at HWRP

The first alternative that includes AWT at HWRP was the preferred approach.

Specifics related to the HPOAS conversion to air-MBR were provided. Information on the design of AWT systems was also reviewed. Related to nitrogen treatment, the benefits of sidestream treatment were reviewed along with potential systems. An implementation strategy, including schedule and cost, is presented as well. The recommended first steps involves a pilot test program for planned technologies.

G.2.2.2 Conditions Update

The flow to HWRP and associated variations will be impacted by diversion to upstream plants and the construction of new satellite facilities. Plans to add food waste to the system will also impact planned treatment systems.

-This Page Left Blank Intentionally-

WASTEWATER IMPROVEMENT PROGRAM DETAILS

H.1 PROJECT CIP DETAILS

Tables H.1-H.5 detail the Project CIP information discussed in Chapter 11.

-This Page Left Blank Intentionally-

| Table H.1 HWRP Escalated and Projected CIP Wastewater Facilities Plan One Water LA 2040 Plan | | | | | | | | | |
|-----------------------------------------------------------------------------------------------------|-----------------|-------------------|------------------------------------------------------------------|----------------------|------------------------------|----------------------------|---------------------------|----------------------------|--------------------------|
| Approved CIP | BOE CIP# | LASAN CIP# | Project Title | Project Phase | Project Type | Near-Term 2018-2020 | Mid-Term 2021-2030 | Long-Term 2031-2040 | Project Cost (\$) |
| X | 2253 | 197 | IPS Odor Control Improvements | Near | Capital Project | \$5,100,000 | | | \$5,100,000 |
| X | 2371 | 855 | Abrasive Blast and Steam Cleaning Facility | Near | Replacement & Rehabilitation | \$3,248,000 | | | \$3,248,000 |
| X | 2376 | 901 | Dilute Polymer System Improvements | Mid | Replacement & Rehabilitation | | \$6,890,000 | | \$6,890,000 |
| X | 2413 | | DSF Improvements | Mid | Replacement & Rehabilitation | | \$5,305,000 | | \$5,305,000 |
| X | 2426 | 1289 | FOG Receiving Station North | Near | Capital Project | \$4,994,000 | | | \$4,994,000 |
| X | 2438 | 1387 | Secondary Clarifiers Upgrade Modules 1-5 | Near | Replacement & Rehabilitation | \$13,473,000 | | | \$13,473,000 |
| X | 2439 | | ELC Equipment Upgrades | Mid | Replacement & Rehabilitation | | \$500,000 | | \$500,000 |
| X | 2441 | 1444 | Digester Corrosion Rehabilitation | Near | Replacement & Rehabilitation | \$8,990,000 | | | \$8,990,000 |
| X | 2443 | 1440 | FeCl2 Injection Facility Replacement | Near | Replacement & Rehabilitation | \$2,050,000 | | | \$2,050,000 |
| X | 2445 | 1441 | Primary Tanks B0, B5, & C0 Upgrades | Near | Capital Project | \$2,918,000 | | | \$2,918,000 |
| X | 2446 | 1442 | Primary Tanks Skimmer Improvements | Near | Replacement & Rehabilitation | \$7,860,000 | | | \$7,860,000 |
| X | 2447 | 1481 | Plant Perimeter Road Improvements | Near | Replacement & Rehabilitation | \$390,000 | | | \$390,000 |
| X | 2448 | | Cryo Facility Upgrade | Mid | Replacement & Rehabilitation | | \$50,000,000 | | \$50,000,000 |
| X | 2451 | 1548 | Digester Battery E Improvements | Near | Replacement & Rehabilitation | \$13,964,000 | | | \$13,964,000 |
| X | 2454 | 1578 | Biosolids Pumping System Upgrades | Near | Replacement & Rehabilitation | \$7,210,000 | | | \$7,210,000 |
| X | 2455 | 1579 | Digester Equipment Improvements Battery - D3 (Battery E), D2, D1 | Mid | Replacement & Rehabilitation | | \$9,000,000 | | \$9,000,000 |
| X | 2456 | | Oxygen Reactor Improvements Modules 1-4 | Near | Capital Project | \$7,000,000 | | | \$7,000,000 |

| Table H.1 HWRP Escalated and Projected CIP Wastewater Facilities Plan One Water LA 2040 Plan | | | | | | | | | |
|-----------------------------------------------------------------------------------------------------|-----------------|-------------------|-------------------------------------------------------|----------------------|------------------------------|----------------------------|---------------------------|----------------------------|--------------------------|
| Approved CIP | BOE CIP# | LASAN CIP# | Project Title | Project Phase | Project Type | Near-Term 2018-2020 | Mid-Term 2021-2030 | Long-Term 2031-2040 | Project Cost (\$) |
| X | 2457 | 1608 | Equipment Storage Facility | Mid | Replacement & Rehabilitation | | \$3,000,000 | | \$3,000,000 |
| X | 2459 | | TSF Mechanical Equipment Upgrades | Near | Replacement & Rehabilitation | \$5,000,000 | | | \$5,000,000 |
| X | 2460 | 1610 | Replace Ferric Chloride Facility | Near | Replacement & Rehabilitation | \$1,676,000 | | | \$1,676,000 |
| X | 2466 | | Headworks Fire Sprinkler Rehabilitation and Recoating | Near | Replacement & Rehabilitation | \$1,000,000 | | | \$1,000,000 |
| X | 2468 | | Parking Structure Crack Repair and Sprinkler Repair | Near | Replacement & Rehabilitation | \$762,000 | | | \$762,000 |
| X | 2470 | | Harrington Bldg Air Quality Improvements | Near | Replacement & Rehabilitation | \$976,000 | | | \$976,000 |
| X | 2471 | | Pregerson Bldg Interior Refurbishment | Near | Replacement & Rehabilitation | \$627,000 | | | \$627,000 |
| X | 2474 | | Headworks Bar Screen Sluice Gate Replacements | Near | Replacement & Rehabilitation | \$4,713,000 | | | \$4,713,000 |
| X | 2477 | | Primary Influent Sluice Gates | Mid | Replacement & Rehabilitation | | \$10,000,000 | | \$10,000,000 |
| X | 2478 | | Oxygen Reactor Improvements Modules 5-9 | Mid | Capital Project | | \$8,000,000 | | \$8,000,000 |
| X | 2480 | | Headworks Truck Loading Area Odor Control Upgrades | Near | Replacement & Rehabilitation | \$940,000 | | | \$940,000 |
| X | 2481 | | Service Water Facility Improvements | Near | Replacement & Rehabilitation | \$1,704,000 | | | \$1,704,000 |
| X | 2483 | | Primary Batteries for Odor Control Facility Upgrades | Mid | Capital Project | | \$23,000,000 | | \$23,000,000 |
| X | 8079 | | LPGH No. 1 Rehabilitation | Near | Replacement & Rehabilitation | \$98,000 | | | \$98,000 |
| X | 8143 | | Central Storm Drain Rerouting | Near | Replacement & Rehabilitation | \$3,420,000 | | | \$3,420,000 |
| X | 8147 | | LPGH Safety & Process Improvement | Near | Replacement & Rehabilitation | \$228,000 | | | \$228,000 |

| Table H.1 HWRP Escalated and Projected CIP Wastewater Facilities Plan One Water LA 2040 Plan | | | | | | | | | |
|-----------------------------------------------------------------------------------------------------|-----------------|-------------------|--------------------------------------------------------------|----------------------|------------------------------|--------------------------------|-------------------------------|--------------------------------|--------------------------|
| Approved CIP | BOE CIP# | LASAN CIP# | Project Title | Project Phase | Project Type | Near-Term 2018-2020 | Mid-Term 2021-2030 | Long-Term 2031-2040 | Project Cost (\$) |
| X | 8152 | | Aqueous Ammonia Storage & Spill Containment Enhancements | Near | Replacement & Rehabilitation | \$1,699,000 | | | \$1,699,000 |
| X | 8155 | | Liquid Oxygen Tank No. 2 Rehabilitation | Near | Replacement & Rehabilitation | \$450,000 | | | \$450,000 |
| X | 8156 | | Cryogenic Facility Technical Assessment | Near | Replacement & Rehabilitation | \$681,000 | | | \$681,000 |
| X | 8157 | | Flare System Access Platforms and Knockout Drum | Near | Replacement & Rehabilitation | \$556,000 | | | \$556,000 |
| X | 8159 | | Headworks Grit Classifier Upgrade | Near | Replacement & Rehabilitation | \$449,000 | | | \$449,000 |
| X | 8160 | | Headworks Bar Screen Sluice Gate Replacements Channel 1 & 10 | Near | Replacement & Rehabilitation | \$913,000 | | | \$913,000 |
| X | 8161 | | Emergency Bypass Channel Rehabilitation | Near | Replacement & Rehabilitation | \$500,000 | | | \$500,000 |
| X | 8162 | | Industrial Water Distribution Modification | Near | Replacement & Rehabilitation | \$565,000 | | | \$565,000 |
| | 8165 | | Screw Pump #6 Gearbox Total Bearing Replacement | Near | Replacement & Rehabilitation | \$150,000 | | | \$150,000 |
| X | 8166 | | Truck Loading Facility Enhancement | Near | Capital Project | \$200,000 | | | \$3,420,000 |
| X | 8179 | | Low Pressure Gas Holder #1 | Near | Replacement & Rehabilitation | \$610,000 | | | \$228,000 |
| | | | Slope Stabilization | Near | Climate Change | \$600,000 | | | \$600,000 |
| | | | Total Estimated CIP | | | \$106M | \$116M | | \$222M |
| | | | Projected Capital Project | Long | | | | \$920,000 | \$920,000 |
| | | | Projected R&R | Long | | | | \$360,000,000 | \$360,000 |
| | | | Total Projected CIP | | | | | \$1,280M | \$1,280M |
| | | | Total Estimated and Projected CIP | | | \$106M | \$116M | \$1,280M | \$1,502M |

-This Page Left Blank Intentionally-

| Table H.2 DCTWRP Escalated and Projected CIP Wastewater Facilities Plan One Water LA 2040 Plan | | | | | | | | | |
|---------------------------------------------------------------------------------------------------------------|-----------------|-------------------|----------------------------------------------|----------------------|------------------------------|--------------------------------|-------------------------------|--------------------------------|--------------------------|
| Approved CIP | BOE CIP# | LASAN CIP# | Project Title | Project Phase | Project Type | Near-Term 2018-2020 | Mid-Term 2021-2030 | Long-Term 2031-2040 | Project Cost (\$) |
| X | 6122 | 1385 | Channel 1 Air Spargers Improvements | Near | Capital Project | \$865,000 | | | \$865,000 |
| X | 6145 | | Backup Power Generation | Near | Climate Resilience | \$7,713,000 | | | \$7,713,000 |
| X | 6192 | 1187 | Multi-Purpose and Office Building | Near | Capital Project | \$19,980,000 | | | \$19,980,000 |
| X | 6194 | 1337 | Multi-Purpose and Office Building Exhibits | Near/Mid | Capital Project | \$1,325,000 | \$1,325,000 | | \$2,650,000 |
| X | 6195 | 1211 | Maintenance Facility Expansion | Near | Capital Project | \$28,000,000 | | | \$28,000,000 |
| X | 6204 | 1467 | Chemical Lines Upgrade | Near | Replacement & Rehabilitation | \$1,150,000 | | | \$1,150,000 |
| X | 6205 | 1459 | Berm Improvements | Near | Climate Resilience | \$4,500,000 | | | \$4,500,000 |
| X | 6207 | | Secondary Clarifier Improvement | Near/Mid | Capital Project | \$5,450,000 | \$5,450,000 | | \$10,900,000 |
| X | 6209 | | Stormwater Interim Treatment System | Near/Mid | Capital Project | \$1,000,000 | \$1,000,000 | | \$2,000,000 |
| X | 6214 | | Administration Building HVAC Replacement | Near | Replacement & Rehabilitation | \$2,882,000 | | | \$2,882,000 |
| X | 6215 | 1596 | Phase 1 Bar Screens | Mid | Capital Project | | \$1,590,000 | | \$1,590,000 |
| X | 6216 | 1597 | Influent Meter and Channel 2 Dump Gate Meter | Near | Capital Project | \$836,000 | | | \$836,000 |
| X | 6217 | 1598 | Primary Settling Tanks Improvements | Mid | Capital Project | | \$12,000,000 | | \$12,000,000 |
| X | 6223 | 1604 | Administration Building Improvements | Near | Replacement & Rehabilitation | \$2,000,000 | | | \$2,000,000 |
| X | 6226 | 1571 | Chlorination System Improvements | Near | Capital Project | \$1,794,000 | | | \$1,794,000 |
| X | 6231 | | AVORS & EVIS Gates Replacement | Near | Replacement & Rehabilitation | \$1,300,000 | | | \$1,300,000 |

| Table H.2 DCTWRP Escalated and Projected CIP Wastewater Facilities Plan One Water LA 2040 Plan | | | | | | | | | |
|-------------------------------------------------------------------------------------------------------|-----------------|-------------------|---------------------------------------------------|----------------------|------------------------------|----------------------------|---------------------------|----------------------------|--------------------------|
| Approved CIP | BOE CIP# | LASAN CIP# | Project Title | Project Phase | Project Type | Near-Term 2018-2020 | Mid-Term 2021-2030 | Long-Term 2031-2040 | Project Cost (\$) |
| X | 6232 | | Underground HPE/LPE Improvements | Near | Capital Project | \$1,434,000 | | | \$1,434,000 |
| X | 6233 | | Disinfection System Conversion of NaOCl to UV | Long | Capital Project | | | \$10,300,000 | \$10,300,000 |
| X | 6234 | | Screw Pump Inlet Gates | Near | Capital Project | \$1,215,000 | | | \$1,215,000 |
| X | 8626 | | LAB Building Roof Protection System | Near | Capital Project | \$96,000 | | | \$96,000 |
| X | 8637 | | Primary Tank HPE Piping Replacement | Near | Replacement & Rehabilitation | \$895,000 | | | \$895,000 |
| X | 8638 | | Niwa Road Sewer Installation | Near | Capital Project | \$293,000 | | | \$293,000 |
| X | 8640 | 1471 | Niwa Road Parking* | Near | Capital Project | \$250,000 | | | \$250,000 |
| X | 8645 | 1573 | Odor Masking Systems Replacement* | Near | Capital Project | \$98,000 | | | \$98,000 |
| X | 8646 | | Lab Building Winch | Near | Capital Project | \$50,000 | | | \$50,000 |
| X | 8649 | | DCTWRP Chlorine Contact Tank HPE System Actuators | Near | Replacement & Rehabilitation | \$1,109,000 | | | \$1,109,000 |
| X | 8650 | | Japanese Garden Electrical System Improvements | Near | Replacement & Rehabilitation | \$295,000 | | | \$295,000 |
| X | 8651 | | Japanese Garden Pond Foundation Improvements* | Near | Replacement & Rehabilitation | \$500,000 | | | \$500,000 |
| X | 8654 | | Japanese Garden ADA Compliance | Near | | \$578,000 | | | \$578,000 |
| X | 8655 | | RAS Ph. 1 & Ph. 2 Tie-In* | Near | Capital Project | \$245,000 | | | \$245,000 |
| X | | | Interim Ozone | Near | Capital Project | \$60,000,000 | | | \$60,000,000 |
| Total Estimated CIP | | | | | | \$146M | \$21M | \$10M | \$177M |
| | | | Projected Capital Project | Mid/Long | | | \$100,000,000 | \$240,000,000 | \$340,000,000 |
| | | | Projected R&R | Long | | | | \$100,000,000 | \$100,000,000 |

| Table H.2 DCTWRP Escalated and Projected CIP Wastewater Facilities Plan One Water LA 2040 Plan | | | | | | | | | |
|---------------------------------------------------------------------------------------------------------------|-----------------|-------------------|----------------------------------------------|----------------------|---------------------|--------------------------------|-------------------------------|--------------------------------|--------------------------|
| Approved CIP | BOE CIP# | LASAN CIP# | Project Title | Project Phase | Project Type | Near-Term 2018-2020 | Mid-Term 2021-2030 | Long-Term 2031-2040 | Project Cost (\$) |
| | | | Total Projected CIP | | | | \$100M | \$340M | \$440M |
| | | | Total Estimated and Projected CIP | | | \$146M | \$121M | \$350M | \$617M |

-This Page Left Blank Intentionally-

| Table H.3 LAGWRP Escalated and Projected CIP Wastewater Facilities Plan One Water LA 2040 Plan | | | | | | | | | |
|---------------------------------------------------------------------------------------------------------------|-----------------|-------------------|----------------------------------------------------|----------------------|------------------------------|--------------------------------|-------------------------------|--------------------------------|--------------------------|
| Approved CIP | BOE CIP# | LASAN CIP# | Project Title | Project Phase | Project Type | Near-Term 2018-2020 | Mid-Term 2021-2030 | Long-Term 2031-2040 | Project Cost (\$) |
| X | 4170 | 1307 | Personnel Building | Near | Replacement & Rehabilitation | \$14,044,000 | | | \$14,044,000 |
| X | 4172 | | Headworks Improvements | Near | Replacement & Rehabilitation | \$2,814,000 | | | \$2,814,000 |
| X | 4176 | | Primary Effluent Equalization Storage | Near | Capital Project | \$17,041,000 | | | \$17,041,000 |
| X | 4177 | 1458 | Stormwater Interim Treatment System | Mid | Capital Project | | \$1,000,000 | | \$1,000,000 |
| X | 4178 | 1472 | Dechlorination Chamber Improvements | Near | Replacement & Rehabilitation | \$1,436,000 | | | \$1,436,000 |
| X | 4179 | | Bisulfite Facility Improvements | Near | Replacement & Rehabilitation | \$1,350,000 | | | \$1,350,000 |
| X | 4184 | | Influent Pumps Replacement | Mid | Replacement & Rehabilitation | | \$3,500,000 | | \$3,500,000 |
| X | 4185 | 1616 | Grit Removal System Upgrade | Mid | Replacement & Rehabilitation | | \$1,500,000 | | \$1,500,000 |
| X | 4187 | 1620 | Blower Air Cleanup System | Near | Replacement & Rehabilitation | \$2,201,000 | | | \$2,201,000 |
| X | 4188 | 1621 | Primary Settling System Rehabilitation | Mid | Replacement & Rehabilitation | | \$10,000,000 | | \$10,000,000 |
| X | 4189 | 1622 | Cover Plates & Grating Replacement | Near | Replacement & Rehabilitation | \$1,070,000 | | | \$1,070,000 |
| X | 4190 | 1623 | Secondary Activated Sludge Reactors Rehabilitation | Near | Replacement & Rehabilitation | \$7,000,000 | | | \$7,000,000 |
| X | 4191 | 1624 | Secondary Clarifiers Rehabilitations | Near | Replacement & Rehabilitation | \$6,000,000 | | | \$6,000,000 |
| X | 4195 | 1627 | LAG Storage Building | Near | Replacement & Rehabilitation | \$1,500,000 | | | \$1,500,000 |
| X | 4199 | | Tertiary Filter Upgrade | Near | Replacement & Rehabilitation | \$1,500,000 | | | \$1,500,000 |
| X | 4200 | | Sodium Hypochlorite Facility Relocation | Near | Replacement & Rehabilitation | \$1,176,000 | | | \$1,176,000 |
| X | 8420 | | Blower No. 1 Inlet Air Supply | Near | Replacement & Rehabilitation | \$95,000 | | | \$95,000 |

| Table H.3 LAGWRP Escalated and Projected CIP Wastewater Facilities Plan One Water LA 2040 Plan | | | | | | | | | |
|-------------------------------------------------------------------------------------------------------|-----------------|-------------------|-----------------------------------------------|----------------------|------------------------------|----------------------------|---------------------------|----------------------------|--------------------------|
| Approved CIP | BOE CIP# | LASAN CIP# | Project Title | Project Phase | Project Type | Near-Term 2018-2020 | Mid-Term 2021-2030 | Long-Term 2031-2040 | Project Cost (\$) |
| X | 8421 | | Primary Cover Plates & Grating Replacement | Near | Replacement & Rehabilitation | \$471,000 | | | \$471,000 |
| X | 8422 | | Tertiary Filter Guard Rail Replacement | Near | Replacement & Rehabilitation | \$40,000 | | | \$40,000 |
| X | | 8417 | Maintenance Building Locker Room Improvements | Near | Replacement & Rehabilitation | \$179,000 | | | \$179,000 |
| | | | Backup Power Generation | Near | Climate Resilience | \$4,000,000 | | | \$4,000,000 |
| | | | Backflow Prevention Gates | Near | Climate Resilience | \$400,000 | | | \$400,000 |
| | | | Floodwalls | Near | Climate Resilience | \$10,000,000 | | | \$10,000,000 |
| | | | Total Estimated CIP | | | \$72M | \$16M | | \$88M |
| | | | Projected Capital Project | Mid/Long | | | \$59,000,000 | \$60,000,000 | \$119,000,000 |
| | | | Projected R&R | Long | | | | \$20,000,000 | \$20,000,000 |
| | | | Total Projected CIP | | | | \$59M | \$80M | \$139M |
| | | | Total Estimated and Projected CIP | | | \$72M | \$75M | \$80M | \$227M |

| Table H.4 TIWRP Escalated and Projected CIP Wastewater Facilities Plan One Water LA 2040 Plan | | | | | | | | | |
|--------------------------------------------------------------------------------------------------------------|-----------------|-------------------|------------------------------------------------|----------------------|---------------------------------|--------------------------------|-------------------------------|--------------------------------|--------------------------|
| Approved CIP | BOE CIP# | LASAN CIP# | Project Title | Project Phase | Project Type | Near-Term 2018-2020 | Mid-Term 2021-2030 | Long-Term 2031-2040 | Project Cost (\$) |
| X | 3335 | 268 | Power/Energy MGMT | Near | Capital Project | \$494,000 | | | \$494,000 |
| X | 5182 | 744 | Fire Protect SYS REPL | Mid | Replacement & Rehabilitation | | \$1,120,000 | | \$1,120,000 |
| X | 5198 | 1015 | Service Maintenance & Warehouse Facility | Near | Replacement & Rehabilitation | \$15,278,000 | | | \$15,278,000 |
| X | 5202 | 1332 | Blending Tank Rehabilitation | Near | Replacement & Rehabilitation | \$1,719,000 | | | \$1,719,000 |
| X | 5223 | 1340 | Tire Facility Enhancement | Near | Capital Project | \$3,180,000 | | | \$3,180,000 |
| X | 5224 | 1317 | Daft Modification | Near | Replacement & Rehabilitation | \$907,000 | | | \$907,000 |
| X | 5228 | 1327 | Biogas System Conditioning | Near | Capital Project | \$1,773,000 | | | \$1,773,000 |
| X | 5238 | | Machado Lake De- Chlorination Station | Near | Capital Project | \$1,477,000 | | | \$1,477,000 |
| X | 5242 | 1581 | Phase I AWPf Membrane Replacement | Near | Replacement & Rehabilitation | \$18,290,000 | | | \$18,290,000 |
| X | 5243 | 1582 | Digester Gas Utilization System | Near | Capital Project | \$5,000,000 | | | \$5,000,000 |
| X | 5244 | 1583 | AWPF Emergency Generators | Near | Capital Project | \$3,000,000 | | | \$3,000,000 |
| X | 5245 | 1584 | Digester Insulation Replacement | Mid | Replacement & Rehabilitation | | \$6,180,000 | | \$6,180,000 |
| X | 5246 | 1585 | Learning Center | Mid | Capital Project | | \$7,725,000 | | \$7,725,000 |
| X | 5247 | 1586 | Primary Treatment Process Modernization | Mid | Replacement & Rehabilitation | | \$8,240,000 | | \$8,240,000 |
| X | 5248 | 1587 | Digester Gas Compressor Replacement | Long | Replacement & Rehabilitation | | | \$2,928,000 | \$2,928,000 |
| X | 5249 | 1588 | EPP Piping System Improvements | Near | Capital Project | \$1,113,000 | | | \$1,113,000 |
| X | 5251 | 1591 | AWPF Enhancement | Mid | Capital Project | | \$10,000,000 | | \$10,000,000 |
| X | 5254 | | Admin Building Refurbishment | Near | Replacement & Rehabilitation | \$2,000,000 | | | \$2,000,000 |

| Table H.4 TIWRP Escalated and Projected CIP Wastewater Facilities Plan One Water LA 2040 Plan | | | | | | | | | |
|------------------------------------------------------------------------------------------------------|-----------------|-------------------|-----------------------------------------------|----------------------|------------------------------|----------------------------|---------------------------|----------------------------|--------------------------|
| Approved CIP | BOE CIP# | LASAN CIP# | Project Title | Project Phase | Project Type | Near-Term 2018-2020 | Mid-Term 2021-2030 | Long-Term 2031-2040 | Project Cost (\$) |
| X | 5255 | | Final Tanks Skimmer System Upgrade | Near | Replacement & Rehabilitation | \$2,894,000 | | | \$2,894,000 |
| X | 5256 | | HPE and Brine Separation | Near | Replacement & Rehabilitation | \$500,000 | | | \$500,000 |
| X | 5257 | | Headworks Odor Control | Near | Replacement & Rehabilitation | \$5,000,000 | | | \$5,000,000 |
| X | 7166 | | SW – Bureau Wide Security System | Long | Replacement & Rehabilitation | | | \$2,648,000 | \$2,648,000 |
| X | 8532 | | High Pressure Gas Holder Rehabilitation | Near | Replacement & Rehabilitation | \$350,000 | | | \$350,000 |
| X | 8533 | 1594 | Truck Scale Relocation | Near | Replacement & Rehabilitation | \$500,000 | | | \$500,000 |
| X | 8534 | 1595 | Site & Drainage Improvements | Near | Replacement & Rehabilitation | \$368,000 | | | \$368,000 |
| X | 8537 | | Emergency Generator Controls Upgrade | Near | Capital Project | \$1,061,000 | | | \$1,061,000 |
| X | | 1592 | Grit Pump Room Ventilation System | Long | Replacement & Rehabilitation | | | \$1,474,000 | \$1,474,000 |
| X | | 1443 | Electricity Usage Monitoring and Optimization | Long | Replacement & Rehabilitation | | | \$5,417,000 | \$5,417,000 |
| | | | Floodwalls | Long | Climate Resilience | | | \$10,000,000 | \$10,000,000 |
| | | | Backup Power Generation | Long | Climate Resilience | | | \$4,000,000 | \$4,000,000 |
| | | | Total Estimated CIP | | | \$65M | \$34M | \$26M | \$125M |
| | | | Projected Capital Project | | | | | \$140,000,000 | \$140,000,000 |
| | | | Projected R&R | | | | | \$38,000,000 | \$38,000,000 |
| | | | Total Projected CIP | | | | | \$178M | \$178M |
| | | | Total Estimated and Projected CIP | | | \$65M | \$34M | \$204M | \$303M |

| Table H.5 Collection System Estimated CIP Wastewater Facilities Plan One Water LA 2040 Plan | | | | | | | | |
|------------------------------------------------------------------------------------------------------------|-----------------------------------|----------------------------|----------------------|------------------------------|--------------------------------|-------------------------------|--------------------------------|--------------------------|
| Approved CIP | Plant No./ Project No. | Project Title | Project Phase | Project Type | Near-Term 2018-2020 | Mid-Term 2021-2030 | Long-Term 2031-2040 | Project Cost (\$) |
| X | 250 | SSRP T07 AVALON AND LOMITA | Near | Replacement & Rehabilitation | \$1,744,000 | | | \$1,744,000 |
| | 614 | Tuxford (LFD) | Near | Climate Resilience | \$90,000 | | | \$90,000 |
| | 624 | Roscomare | Near | Climate Resilience | \$20,000 | | | \$20,000 |
| | 634 | Temescal | Near | Climate Resilience | \$60,000 | | | \$60,000 |
| | 639 | North Pulga | Near | Climate Resilience | \$60,000 | | | \$60,000 |
| | 646 | Venice Pumping Plant | Long | Climate Resilience | | | \$1,600,000 | \$1,600,000 |
| | 647 | Kinney Circle | Near | Climate Resilience | \$610,000 | | | \$610,000 |
| | 648 | Thompson | Long | Climate Resilience | | | \$480,000 | \$480,000 |
| | 649 | Jefferson | Long | Climate Resilience | | | \$80,000 | \$80,000 |
| | 666 | Fries Ave | Mid | Climate Resilience | | \$1,110,000 | | \$1,110,000 |
| | 668 | Henry Ford | Near | Climate Resilience | \$230,000 | | | \$230,000 |
| | 669 | Harris Place | Long | Climate Resilience | | | \$810,000 | \$810,000 |
| | 671 | Terminal Way | Long | Climate Resilience | | | \$1,070,000 | \$1,070,000 |
| | 672 | Murdock & I | Long | Climate Resilience | | | \$720,000 | \$720,000 |
| | 676 | Mcfarland | Long | Climate Resilience | | | \$1,020,000 | \$1,020,000 |
| | 677 | Hawaiian & "B" | Long | Climate Resilience | | | \$870,000 | \$870,000 |
| | 680 | 22nd & Signal | Long | Climate Resilience | | | \$126,000 | \$126,000 |
| | 681 | Ports 'O' Call | Long | Climate Resilience | | | \$340,000 | \$340,000 |
| | 683 | 22nd Street | Long | Climate Resilience | | | \$500,000 | \$500,000 |
| | 684 | Miner | Long | Climate Resilience | | | \$500,000 | \$500,000 |
| | 685 | Signal | Long | Climate Resilience | | | \$480,000 | \$480,000 |
| | 686 | Nissan Way | Long | Climate Resilience | | | \$490,000 | \$490,000 |
| | 687 | North Neptune | Mid | Climate Resilience | | \$400,000 | | \$400,000 |
| | 689 | Seaside | Long | Climate Resilience | | | \$600,000 | \$600,000 |
| | 690 | Anchorage | Long | Climate Resilience | | | \$300,000 | \$300,000 |
| | 691 | San Pedro | Long | Climate Resilience | | | \$1,080,000 | \$1,080,000 |
| | 733 | Santa Monica | Near | Climate Resilience | \$140,000 | | | \$140,000 |
| | 734 | Temescal | Near | Climate Resilience | \$60,000 | | | \$60,000 |

| Table H.5 Collection System Estimated CIP Wastewater Facilities Plan One Water LA 2040 Plan | | | | | | | | |
|------------------------------------------------------------------------------------------------------------|-----------------------------------|-----------------------------------|----------------------|---------------------------------|--------------------------------|-------------------------------|--------------------------------|--------------------------|
| Approved CIP | Plant No./ Project No. | Project Title | Project Phase | Project Type | Near-Term 2018-2020 | Mid-Term 2021-2030 | Long-Term 2031-2040 | Project Cost (\$) |
| | 740 | Westside Park | Near | Climate Resilience | \$90,000 | | | \$90,000 |
| X | 6205 | SSRP W20 VENTURA AND TAMPA | Near | Replacement & Rehabilitation | \$2,643,000 | | | \$2,643,000 |
| X | 7181 | PP677 HAWAIIAN & B REHAB | Near | Replacement & Rehabilitation | \$1,430,000 | | | \$1,430,000 |
| X | 7182 | PP676 WILMINGTON REHAB | Near | Replacement & Rehabilitation | \$1,523,000 | | | \$1,523,000 |
| X | 7183 | PP666 FRIES REHAB | Near | Replacement & Rehabilitation | \$1,532,000 | | | \$1,532,000 |
| X | 7184 | PP604 HIGHBURY REHAB | Near | Replacement & Rehabilitation | \$2,205,000 | | | \$2,205,000 |
| X | 7185 | PP671 TERMINAL WAY REHAB | Near | Replacement & Rehabilitation | \$2,824,000 | | | \$2,824,000 |
| X | 7186 | PP691 SAN PEDRO REHAB | Near | Replacement & Rehabilitation | \$2,335,000 | | | \$2,335,000 |
| X | 7187 | ODOR CNTR MLK & RODEO FAC UPG | Near | Capital Project | \$850,000 | | | \$850,000 |
| X | 7188 | ODOR CTR NORS-ECIS SCR FAC UPG | Near | Capital Project | \$1,026,000 | | | \$1,026,000 |
| X | 7190 | ODOR CNTR RADFORD SCRB FAC UPG | Near | Capital Project | \$1,121,000 | | | \$1,121,000 |
| X | 7191 | ODOR CTR RICHMOND SCRB FAC UPG | Near | Capital Project | \$1,302,000 | | | \$1,302,000 |
| X | 7192 | ODOR CNTRL NOTF SCRUBBER UPG | Near | Capital Project | \$1,302,000 | | | \$1,302,000 |
| X | 7193 | ODOR CTR SIERRA BONITA FAC UPG | Near | Capital Project | \$1,302,000 | | | \$1,302,000 |
| X | 7194 | ODOR CTR HUMBOLDT SCRB FAC UPG | Near | Capital Project | \$1,302,000 | | | \$1,302,000 |
| X | 7195 | ODOR CNT BALLONA SCRUB FAC UPG | Near | Capital Project | \$1,121,000 | | | \$1,121,000 |
| X | 7196 | ODOR CNTR DACOTAH SCRB FAC UPG | Near | Capital Project | \$747,000 | | | \$747,000 |
| X | 7198 | NCOS JEFFERSON HOLDREDGE VAULT | Near | Replacement & Rehabilitation | \$722,000 | | | \$722,000 |

| Table H.5 Collection System Estimated CIP Wastewater Facilities Plan One Water LA 2040 Plan | | | | | | | | |
|------------------------------------------------------------------------------------------------------------|-----------------------------------|------------------------------------|----------------------|---------------------------------|--------------------------------|-------------------------------|--------------------------------|--------------------------|
| Approved CIP | Plant No./ Project No. | Project Title | Project Phase | Project Type | Near-Term 2018-2020 | Mid-Term 2021-2030 | Long-Term 2031-2040 | Project Cost (\$) |
| X | 7199 | ODOR CTRL GENESEE SCRUB FAC INS | Near | Capital Project | \$320,000 | | | \$320,000 |
| X | 7222 | PP646 VENICE GENERATORS REPL | Near | Replacement & Rehabilitation | \$5,039,000 | | | \$5,039,000 |
| X | 7223 | PP674 190 & VERMONT GEN REPL | Near | Replacement & Rehabilitation | \$502,000 | | | \$502,000 |
| X | 7229 | PP672 MURDOCK & I GEN REPL | Near | Replacement & Rehabilitation | \$382,000 | | | \$382,000 |
| X | 7230 | PP601 MANCHESTER GEN REPL | Near | Replacement & Rehabilitation | \$1,043,000 | | | \$1,043,000 |
| X | 7231 | PP606 DACOTAH GENERATORS REPL | Near | Replacement & Rehabilitation | \$747,000 | | | \$747,000 |
| X | 7232 | PP669 HARRIS PL GENERATR REPL | Near | Replacement & Rehabilitation | \$388,000 | | | \$388,000 |
| X | 7237 | PP NORTH YARD GENERATOR REPL | Near | Replacement & Rehabilitation | \$472,000 | | | \$472,000 |
| X | 7238 | PP WEST LA YARD GEN REPL | Near | Replacement & Rehabilitation | \$109,000 | | | \$109,000 |
| X | 7239 | PP616 CAHUENGA GEN REPL | Near | Replacement & Rehabilitation | \$156,000 | | | \$156,000 |
| X | 7240 | PP624 ROSCOMARE GEN REPL | Near | Replacement & Rehabilitation | \$156,000 | | | \$156,000 |
| X | 7241 | PP632 SUNSET GEN REPL | Near | Replacement & Rehabilitation | \$700,000 | | | \$700,000 |
| X | 7242 | PP638 PALISADES GEN REPL | Near | Replacement & Rehabilitation | \$393,000 | | | \$393,000 |
| X | 7243 | PP648 THOMPSON YARD GEN REPL | Near | Replacement & Rehabilitation | \$397,000 | | | \$397,000 |
| X | 7244 | PP654 BALLONA CREEK GEN REPL | Near | Replacement & Rehabilitation | \$2,852,000 | | | \$2,852,000 |
| X | 7249 | PP601 MANCHESTER IMPROVEMENTS | Near | Replacement & Rehabilitation | \$650,000 | | | \$650,000 |
| X | 7250 | GENESEE CARBON SCRUBBER PROC | Near | Replacement & Rehabilitation | \$754,000 | | | \$754,000 |
| X | 7252 | SAN PEDRO PP FORCE MAIN MOD | Near | Capital Project | \$69,000 | | | \$69,000 |

| Table H.5 Collection System Estimated CIP Wastewater Facilities Plan One Water LA 2040 Plan | | | | | | | | |
|------------------------------------------------------------------------------------------------------------|-----------------------------------|-----------------------------------|----------------------|---------------------------------|--------------------------------|-------------------------------|--------------------------------|--------------------------|
| Approved CIP | Plant No./ Project No. | Project Title | Project Phase | Project Type | Near-Term 2018-2020 | Mid-Term 2021-2030 | Long-Term 2031-2040 | Project Cost (\$) |
| X | C191 | PP VENICE DUAL FORCE MAIN | Near | Capital Project | \$88,300,000 | | | \$88,300,000 |
| X | C195 | PP VENICE DISCHARGE MANIF REPL | Near | Replacement & Rehabilitation | \$5,834,000 | | | \$5,834,000 |
| X | C245 | HIGHLAND PK EAGLE ROCK SWR RHB | Near | Replacement & Rehabilitation | \$1,837,000 | | | \$1,837,000 |
| X | C263 | SLAUSON COMPTON SWR REHAB | Near | Replacement & Rehabilitation | \$16,794,000 | | | \$16,794,000 |
| X | C278 | WILSHIRE AREA OLYM SWR REHAB | Near | Replacement & Rehabilitation | \$1,081,000 | | | \$1,081,000 |
| X | C279 | WILSHIRE AREA SYSSWR REHAB | Near | Replacement & Rehabilitation | \$4,843,000 | | | \$4,843,000 |
| X | C689 | UPPER BEACHWOOD EASEMNT MH ADD | Near | Capital Project | \$871,000 | | | \$871,000 |
| X | C707 | NOS REHAB U-1 VAN NESS WESTERN | Near | Replacement & Rehabilitation | \$9,182,000 | | | \$9,182,000 |
| X | C728 | ENTERPRISE ST SIPHON MOD | Near | Replacement & Rehabilitation | \$1,770,000 | | | \$1,770,000 |
| X | C771 | SAN PEDRO SIPHON UPSTREAM 30" | Near | Replacement & Rehabilitation | \$2,013,000 | | | \$2,013,000 |
| X | C782 | NORMANDIE SWR REPL/REHAB | Near | Replacement & Rehabilitation | \$10,007,000 | | | \$10,007,000 |
| X | C812 | NOS REHAB U-3 VERMONT TO TRIN | Near | Replacement & Rehabilitation | \$13,519,000 | | | \$13,519,000 |
| X | C815 | NOS REHAB U-6 HOOPER WILSON | Near | Replacement & Rehabilitation | \$10,609,000 | | | \$10,609,000 |
| X | C816 | NOS REHAB U-7 WILSON LA RIVER | Near | Replacement & Rehabilitation | \$7,498,000 | | | \$7,498,000 |
| X | C817 | NOS REHAB U-8 6TH TO 8TH ST RW | Near | Replacement & Rehabilitation | \$10,995,000 | | | \$10,995,000 |
| X | C818 | NOS REHAB U-9 ALISO TO 6TH | Near | Replacement & Rehabilitation | \$12,530,000 | | | \$12,530,000 |
| X | C821 | NOS REHAB U-12 DUVAL HUMBOLDT | Mid | Replacement & Rehabilitation | | \$14,600,000 | | \$14,600,000 |
| X | C822 | NOS REHAB U-13 FORNEY TO DUVAL | Near | Replacement & Rehabilitation | \$15,103,000 | | | \$15,103,000 |

| Table H.5 Collection System Estimated CIP Wastewater Facilities Plan One Water LA 2040 Plan | | | | | | | | |
|------------------------------------------------------------------------------------------------------------|-----------------------------------|-----------------------------------|----------------------|---------------------------------|--------------------------------|-------------------------------|--------------------------------|--------------------------|
| Approved CIP | Plant No./ Project No. | Project Title | Project Phase | Project Type | Near-Term 2018-2020 | Mid-Term 2021-2030 | Long-Term 2031-2040 | Project Cost (\$) |
| X | C826 | NOS REHAB U-18 COLORADO DORAN | Near | Replacement & Rehabilitation | \$12,781,000 | | | \$12,781,000 |
| X | C851 | SSRP H31 BEACHWOOD & SCENIC | Near | Replacement & Rehabilitation | \$5,786,000 | | | \$5,786,000 |
| X | C865 | CONCORD STREET RELIEF SWR | Mid | Capital Project | | \$3,500,000 | | \$3,500,000 |
| X | C866 | PIERCE & WOODMAN DIVERSION SWR | Near | Capital Project | \$558,000 | | | \$558,000 |
| X | C867 | ARLINGTON/JEFFERSON DVRSN SWR | Near | Replacement & Rehabilitation | \$1,794,000 | | | \$1,794,000 |
| X | C868 | VENICE BLVD INTERCEPTOR U2 | Near | Capital Project | \$9,333,000 | | | \$9,333,000 |
| X | C872 | SSRP N03 ADAMS BL & COMPTON AV | Near | Replacement & Rehabilitation | \$940,000 | | | \$940,000 |
| X | C873 | SSRP N06A 36TH PL & VERMONT | Near | Replacement & Rehabilitation | \$524,000 | | | \$524,000 |
| X | C874 | SSRP N06B ADAMS & HILL | Near | Replacement & Rehabilitation | \$943,000 | | | \$943,000 |
| X | C878 | SSRP H11 BURNSIDE & WILSHIRE | Near | Replacement & Rehabilitation | \$436,000 | | | \$436,000 |
| X | C879 | SSRP N07 BROADWAY & PICO | Near | Replacement & Rehabilitation | \$6,054,000 | | | \$6,054,000 |
| X | C882 | SSRP S07 76TH ST & GRAND AVE | Near | Replacement & Rehabilitation | \$192,000 | | | \$192,000 |
| X | C883 | SSRP S08 MAIN & MANCHESTER | Near | Replacement & Rehabilitation | \$809,000 | | | \$809,000 |
| X | C892 | SSRP S14 HOOVER & VERNON | Near | Replacement & Rehabilitation | \$1,685,000 | | | \$1,685,000 |
| X | C894 | SSRP P17 CYPRESS & DIVISION | Near | Replacement & Rehabilitation | \$5,719,000 | | | \$5,719,000 |
| X | C895 | SSRP P20 COLORADO & TOWNSEND | Near | Replacement & Rehabilitation | \$1,813,000 | | | \$1,813,000 |
| X | C896 | SSRP Z18A CENTURY & MAIN | Near | Replacement & Rehabilitation | \$2,730,000 | | | \$2,730,000 |
| X | C897 | SSRP Z18B IMPERIAL & AVALON | Near | Replacement & Rehabilitation | \$1,796,000 | | | \$1,796,000 |

| Table H.5 Collection System Estimated CIP Wastewater Facilities Plan One Water LA 2040 Plan | | | | | | | | |
|------------------------------------------------------------------------------------------------------------|-----------------------------------|--------------------------------------|----------------------|---------------------------------|--------------------------------|-------------------------------|--------------------------------|--------------------------|
| Approved CIP | Plant No./ Project No. | Project Title | Project Phase | Project Type | Near-Term 2018-2020 | Mid-Term 2021-2030 | Long-Term 2031-2040 | Project Cost (\$) |
| X | C898 | LCIS REHAB BLACKWELDER OLYMPIC | Near | Replacement & Rehabilitation | \$22,528,000 | | | \$22,528,000 |
| X | C911 | SSRP P07 HUNTINGTON & POPLAR | Near | Replacement & Rehabilitation | \$1,751,000 | | | \$1,751,000 |
| X | C912 | DOWNTOWN & ECHO PARK SWR REHAB | Near | Replacement & Rehabilitation | \$2,455,000 | | | \$2,455,000 |
| X | C913 | SSRP P19 FIGUEROA & YOSEMITE | Near | Replacement & Rehabilitation | \$5,003,000 | | | \$5,003,000 |
| X | C914 | DAR 03 EAGLE ROCK & LOS FELIZ | Near | Replacement & Rehabilitation | \$6,707,000 | | | \$6,707,000 |
| X | C917 | SSRP N09 LORENA & WHITTIER | Near | Replacement & Rehabilitation | \$2,897,000 | | | \$2,897,000 |
| X | C918 | SSRP P06 EL SERENO & EDISON | Near | Replacement & Rehabilitation | \$8,682,000 | | | \$8,682,000 |
| X | C919 | SSRP S13 VERNON & BUDLONG | Near | Replacement & Rehabilitation | \$1,103,000 | | | \$1,103,000 |
| X | C920 | SSRP P08 DALY ST & AVENUE 26 | Near | Replacement & Rehabilitation | \$1,985,000 | | | \$1,985,000 |
| X | C921 | JEF BUDLONG GRAMERCY SWR REHAB | Near | Replacement & Rehabilitation | \$555,000 | | | \$555,000 |
| X | C922 | VENICE AUXILIARY PUMPING PLANT | Near | Capital Project | \$17,029,000 | | | \$17,029,000 |
| X | C923 | CHANDLER LANKERSHIM SWR IMP | Near | Replacement & Rehabilitation | \$2,844,000 | | | \$2,844,000 |
| X | C924 | DAR 04 EAGLE ROCK & LINCOLN HT | Near | Replacement & Rehabilitation | \$5,532,000 | | | \$5,532,000 |
| X | C925 | SSRP N14 TEMPLE & GLENDALE | Near | Replacement & Rehabilitation | \$2,894,000 | | | \$2,894,000 |
| X | C926 | COCHRAN ADAMS RELIEF SEWER | Near | Capital Project | \$7,520,000 | | | \$7,520,000 |
| X | C927 | SSRP P04 MISSION & SOTO | Near | Replacement & Rehabilitation | \$3,843,000 | | | \$3,843,000 |
| X | C928 | SSRP H22 MELROSE & WILTON | Near | Replacement & Rehabilitation | \$2,489,000 | | | \$2,489,000 |

| Table H.5 Collection System Estimated CIP Wastewater Facilities Plan One Water LA 2040 Plan | | | | | | | | |
|------------------------------------------------------------------------------------------------------------|-----------------------------------|--------------------------------|----------------------|------------------------------|--------------------------------|-------------------------------|--------------------------------|--------------------------|
| Approved CIP | Plant No./ Project No. | Project Title | Project Phase | Project Type | Near-Term 2018-2020 | Mid-Term 2021-2030 | Long-Term 2031-2040 | Project Cost (\$) |
| X | C929 | SSRP Z24 LA BREA & 63RD | Near | Replacement & Rehabilitation | \$577,000 | | | \$577,000 |
| X | C930 | SSRP P22 VERDUGO & PALMER | Mid | Replacement & Rehabilitation | | \$2,400,000 | | \$2,400,000 |
| X | C931 | ARLINGTON AVE SEWER REHAB | Near | Replacement & Rehabilitation | \$9,516,000 | | | \$9,516,000 |
| X | C934 | SSRP P01A RIVERSIDE & DORRIS | Near | Replacement & Rehabilitation | \$5,289,000 | | | \$5,289,000 |
| X | C935 | LCIS U 7-8 REHAB AL VISTA VINE | Near | Replacement & Rehabilitation | \$2,817,000 | | | \$2,817,000 |
| X | C937 | SSRP P01B DALY & NORTH MAIN | Mid | Replacement & Rehabilitation | | \$3,900,000 | | \$3,900,000 |
| X | C938 | SSRP N04 WASHINGTON & SOTO | Near | Replacement & Rehabilitation | \$1,921,000 | | | \$1,921,000 |
| X | C939 | SSRP U07 CENTINELA & IDAHO | Near | Replacement & Rehabilitation | \$732,000 | | | \$732,000 |
| X | C940 | SSRP N11 7TH ST & VALENCIA ST | Near | Replacement & Rehabilitation | \$2,605,000 | | | \$2,605,000 |
| X | C941 | SSRP H09 PICO & HAUSER | Near | Replacement & Rehabilitation | \$1,228,000 | | | \$1,228,000 |
| X | C942 | SAN FERNANDO RD RELIEF SEWER | Near | Capital Project | \$73,600,000 | | | \$73,600,000 |
| X | C944 | NAOMI AVENUE SEWER UPSIZING | Near | Capital Project | \$6,234,000 | | | \$6,234,000 |
| X | C946 | DAR 05 HOLLYWOOD/WILSHIRE | Near | Replacement & Rehabilitation | \$4,749,000 | | | \$4,749,000 |
| X | C947 | DAR 06 NORTHEAST LOS ANGELES | Mid | Replacement & Rehabilitation | | \$11,940,000 | | \$11,940,000 |
| X | C948 | SSRP C05 LINCOLN BL & ROSE AVE | Near | Replacement & Rehabilitation | \$1,565,000 | | | \$1,565,000 |
| X | C949 | SSRP E20 VENTURA & KESTER | Mid | Replacement & Rehabilitation | | \$10,500,000 | | \$10,500,000 |
| X | C950 | SSRP N10 PICO BL & UNION AVE | Near | Replacement & Rehabilitation | \$4,623,000 | | | \$4,623,000 |
| X | C951 | 74TH ST SWR REHAB UNIT 1 | Near | Replacement & Rehabilitation | \$9,258,000 | | | \$9,258,000 |

| Table H.5 Collection System Estimated CIP Wastewater Facilities Plan One Water LA 2040 Plan | | | | | | | | |
|------------------------------------------------------------------------------------------------------------|-----------------------------------|---------------------------------|----------------------|------------------------------|--------------------------------|-------------------------------|--------------------------------|--------------------------|
| Approved CIP | Plant No./ Project No. | Project Title | Project Phase | Project Type | Near-Term 2018-2020 | Mid-Term 2021-2030 | Long-Term 2031-2040 | Project Cost (\$) |
| X | C952 | SSRP A05 111TH ST & LA CIENEGA | Near | Replacement & Rehabilitation | \$2,211,000 | | | \$2,211,000 |
| X | C953 | SSRP H07 WASHINGTON & HAUSER | Near | Replacement & Rehabilitation | \$638,000 | | | \$638,000 |
| X | C954 | SSRP P02 CESAR CHAVEZ & SOTO | Near | Replacement & Rehabilitation | \$3,993,000 | | | \$3,993,000 |
| X | C959 | DAR 08 WESTCHESTER AND WILSHIRE | Mid | Replacement & Rehabilitation | | \$7,000,000 | | \$7,000,000 |
| X | C969 | SSRP W33 VENTURA AND GLADE | Near | Replacement & Rehabilitation | \$2,436,000 | | | \$2,436,000 |
| X | C972 | SSRP H08 21 ST AND LA BREA AVE | Near | Replacement & Rehabilitation | \$545,000 | | | \$545,000 |
| X | C973 | DAR 07A N HOLLYWOOD SUNLAND | Mid | Replacement & Rehabilitation | | \$5,300,000 | | \$5,300,000 |
| X | G623 | MAINTENANCE YARD-SOUTH DST | Near | Capital Project | \$8,420,000 | | | \$8,420,000 |
| X | G672 | MAINTENANCE YARD-HOLLYWOOD FAC | Near | Capital Project | \$7,963,000 | | | \$7,963,000 |
| X | G673 | MAINTENANCE YARD-N HOLLYWOOD | Mid | Capital Project | | \$9,300,000 | | \$9,300,000 |
| X | Sanc0085 | MAINTENANCE HOLE RESETTING | Near | Replacement & Rehabilitation | \$18,572,000 | | | \$18,572,000 |
| X | ZOO | LA Zoo | Near | Climate Resilience | \$960,000 | | | \$960,000 |
| X | | MAINTENANCE YARD-RESEDA | Near | Capital Project | \$7,562,000 | | | \$7,562,000 |
| X | | NOS REHAB U-28 101 FWY TO BECK | Long | Replacement & Rehabilitation | | | \$11,000,000 | \$11,000,000 |
| X | | NOS REHAB PROGRAM | Near | Replacement & Rehabilitation | \$21,373,000 | | | \$21,373,000 |
| X | | NOS REHAB U-4: 41ST TO 23RD | Near | Replacement & Rehabilitation | \$16,302,000 | | | \$16,302,000 |
| X | | NOS REHAB U-14 MARSH ST FORNEY | Near | Replacement & Rehabilitation | \$13,951,000 | | | \$13,951,000 |
| X | | SSRP Z28 ROSECRANS AND VERMONT | Near | Replacement & Rehabilitation | \$2,248,000 | | | \$2,248,000 |

| Table H.5 Collection System Estimated CIP Wastewater Facilities Plan One Water LA 2040 Plan | | | | | | | | |
|------------------------------------------------------------------------------------------------------------|-----------------------------------|-----------------------------------|----------------------|---------------------------------|--------------------------------|-------------------------------|--------------------------------|--------------------------|
| Approved CIP | Plant No./ Project No. | Project Title | Project Phase | Project Type | Near-Term 2018-2020 | Mid-Term 2021-2030 | Long-Term 2031-2040 | Project Cost (\$) |
| X | | SSRP E10 FOOTHILL & COMMERCE | Near | Replacement & Rehabilitation | \$1,518,000 | | | \$1,518,000 |
| X | | SSRP E06 LA TUNA CANYON | Near | Replacement & Rehabilitation | \$727,000 | | | \$727,000 |
| X | | SSRP W34 BURBANK BL SHOUP AVE | Near | Replacement & Rehabilitation | \$716,000 | | | \$716,000 |
| X | | PP654 BALLONA CREEK REHAB | Near | Replacement & Rehabilitation | \$250,000 | | | \$250,000 |
| X | | PP602 UNION PACIF REHAB | Near | Replacement & Rehabilitation | \$105,000 | | | \$105,000 |
| X | | MAINTENANCE YARD- WLA FACILITY | Mid | Capital Project | | \$7,800,000 | | \$7,800,000 |
| | | Total Estimated CIP | | | \$641M | \$78M | \$22M | \$741M |

-This Page Left Blank Intentionally-



carollo
Engineers...Working Wonders With Water®

in collaboration with

