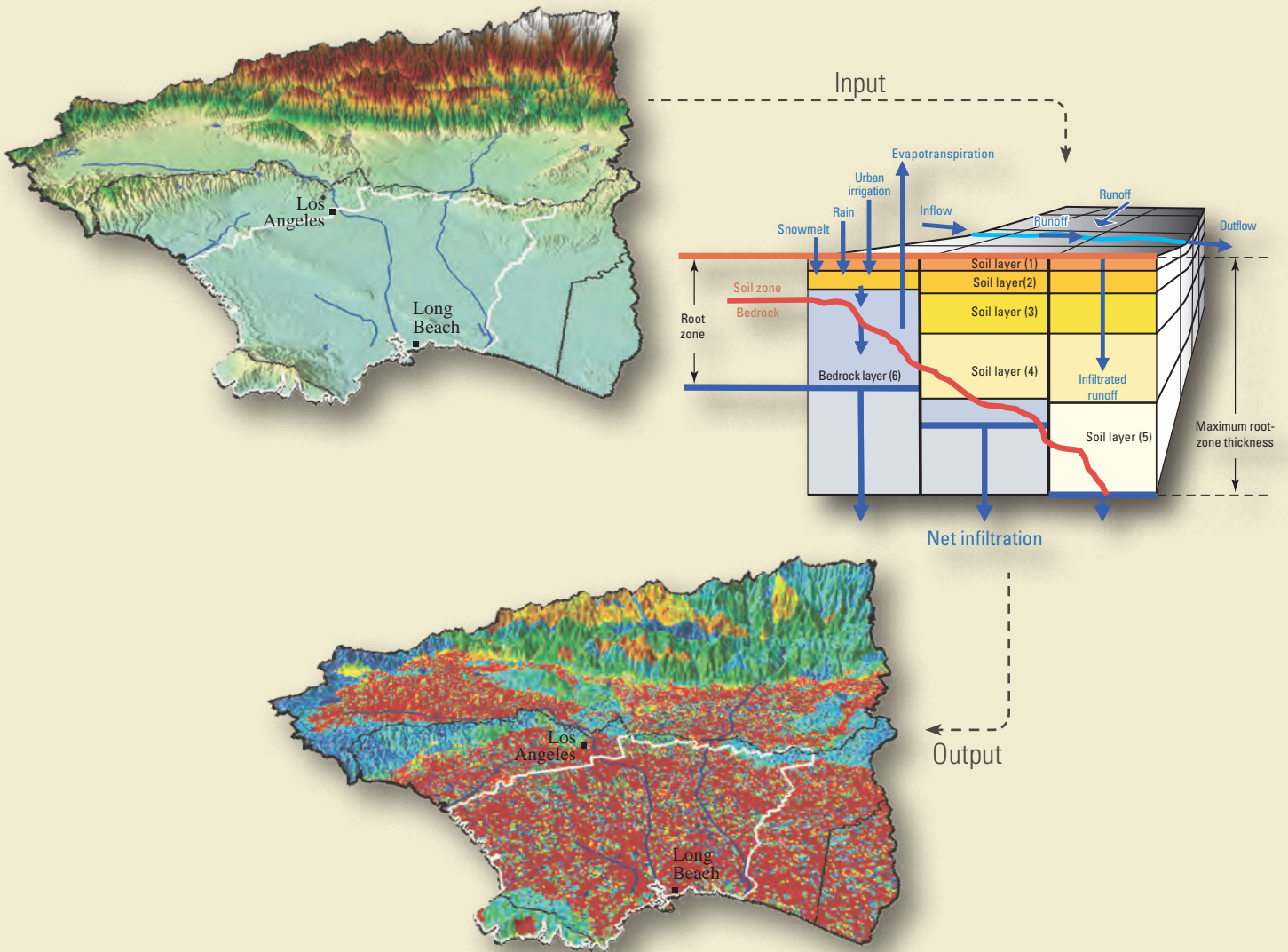
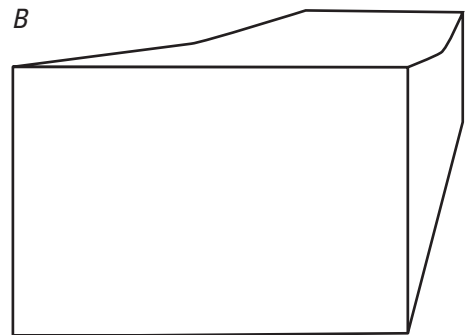


Prepared in cooperation with the Water Replenishment District of Southern California

# Estimating Spatially and Temporally Varying Recharge and Runoff from Precipitation and Urban Irrigation in the Los Angeles Basin, California



Scientific Investigations Report 2016–5068



**Cover.** *A*, Los Angeles Basin watershed model (LABWM) elevation; *B*, Schematic showing the grid, water storage components, and flow processes used by the INFILv3 code to simulate the spatial distribution of flows by the Los Angeles Basin watershed model, California of the multi-layered root zone; *C*, Spatially distributed average annual recharge using the Los Angeles Basin watershed model, California.

# **Estimating Spatially and Temporally Varying Recharge and Runoff from Precipitation and Urban Irrigation in the Los Angeles Basin, California**

By Joseph A. Hevesi and Tyler D. Johnson

Prepared in cooperation with the Water Replenishment District of Southern California

Scientific Investigations Report 2016–5068

**U.S. Department of the Interior**  
**U.S. Geological Survey**

**U.S. Department of the Interior**  
SALLY JEWELL, Secretary

**U.S. Geological Survey**  
Suzette M. Kimball, Director

U.S. Geological Survey, Reston, Virginia: 2016

For more information on the USGS—the Federal source for science about the Earth, its natural and living resources, natural hazards, and the environment—visit <http://www.usgs.gov> or call 1–888–ASK–USGS.

For an overview of USGS information products, including maps, imagery, and publications, visit <http://www.usgs.gov/pubprod/>.

Any use of trade, firm, or product names is for descriptive purposes only and does not imply endorsement by the U.S. Government.

Although this information product, for the most part, is in the public domain, it also may contain copyrighted materials as noted in the text. Permission to reproduce copyrighted items must be secured from the copyright owner.

Suggested citation:

Hevesi, J.A., and Johnson, T.D., 2016, Estimating spatially and temporally varying recharge and runoff from precipitation and urban irrigation in the Los Angeles Basin, California: U.S. Geological Survey Scientific Investigations Report 2016–5068, 192 p., <http://dx.doi.org/10.3133/sir20165068>.

ISSN 2328-0328 (online)



## Acknowledgments

The authors would like to acknowledge the support of the Water Replenishment District of Southern California who cooperatively funded this study.

The authors would like to also acknowledge several individuals who contributed to the technical content of this study, including technical reviewers John C. Risely (U.S. Geological Survey, Oregon Water Science Center) and Allen H. Christensen (California Water Science Center, CAWSC), surface-water specialist reviewer Kara M. Watson (New Jersey Water Science Center), and program chief reviewers Claudia Faunt and Debra S. Curry (CAWSC).

## Contents

Abstract.....	1
Introduction.....	2
Purpose and Scope .....	2
Description of Study Area .....	5
Influence of Urban Irrigation .....	23
Model Description .....	23
Root-Zone Water Balance.....	26
Shallow Perched-Zone Fluxes .....	28
Urban Irrigation .....	28
Model Development .....	31
Simulation Period .....	31
Spatial and Temporal Discretization .....	31
Horizontal Discretization .....	31
Vertical Discretization .....	32
Spatially Distributed Model Parameters.....	36
Topographic Parameters .....	36
Land Cover Parameters .....	36
Vegetation and Root-Zone Parameters.....	41
Soil Parameters.....	41
Geohydrologic Parameters .....	41
Climate Inputs.....	49
Atmospheric Parameters .....	55
Model Coefficients.....	55
Boundary Conditions .....	55
Initial Conditions.....	56
Model Calibration.....	56
Streamflow Observations .....	56
Calibration Procedure .....	61
Calibration Results.....	61
Compton Creek (gage COMP4).....	61
Ballona Creek (gage BALC6).....	61
Coyote Creek (gage COYC1).....	65
Toponga Creek (gage TOPG1).....	65
Alhambra Wash (gage ALHW6).....	65
San Jose Creek (SJCE1) .....	65
Monthly Streamflow .....	65
Annual Streamflow .....	71
Model Sensitivity.....	71
Calibration Summary .....	71

## Contents—Continued

Model Application.....	71
Simulation Results, Water Years 1915–2014.....	73
Potential Evapotranspiration .....	73
Evapotranspiration .....	73
Runoff .....	73
Recharge .....	79
Annual Results.....	79
Annual Time Series.....	79
Comparison of Recharge for Wet and Dry Years.....	84
Average Monthly Results .....	84
Recharge Estimates Developed for the LAGSA.....	88
Effect of Urban Irrigation on Recharge .....	88
Comparison with Previous Recharge Estimates .....	101
Model Limitations.....	106
Summary and Conclusions.....	107
References Cited.....	108
Appendix 1.....	113
Appendix 2.....	121
Appendix 3.....	129

## Figures

1. Maps showing the Los Angeles Basin watershed model area, southern California: <i>A</i> , Los Angeles groundwater basins and related study areas; <i>B</i> , major surface-water drainages.....	3
2. Map showing land cover and land use for the Los Angeles Basin watershed model area, southern California region, California .....	6
3. Graphs showing average monthly values estimated for water years 1915–2014 for the Los Angeles Basin watershed model area, California, for <i>A</i> , precipitation; and <i>B</i> , maximum and minimum daily air temperature.....	22
4. Map showing average annual precipitation estimated for water years 1915–2014 for the Los Angeles Basin watershed model, California.....	24
5. Map showing average air temperature estimated for water years 1915–2014 for the Los Angeles Basin watershed model, California.....	25
6. Schematics showing the grid, water storage components, and flow processes used by the INFILv3 code to simulate the spatial distribution of flows by the Los Angeles Basin watershed model, California: <i>A</i> , the multi-layered root zone; <i>B</i> , the perched zone .....	27
7. Time-series plot of the average water delivery to 1,795 single-family residential homes in the San Fernando Valley, Los Angeles Basin watershed model, California .....	30

## Figures—Continued

8.	Maps showing the grid-cell flow-routing network, Los Angeles Basin watershed model, California: <i>A</i> , National Hydrography Data streams and Los Angeles County storm drains used to define the D-8 grid cell routing network; <i>B</i> , modeled streamlines as indicated by the number of upstream cells.....	33
9.	Map showing the twelve INFILv3 subdomains included in the Los Angeles Basin watershed model, California.....	35
10.	Map showing average land-surface slope, Los Angeles Basin watershed model, California.....	37
11.	Map showing average land-surface aspect, Los Angeles Basin watershed model, California.....	38
12.	Map showing the percentage of impervious area, Los Angeles Basin watershed model, California.....	39
13.	Map showing percentage of forest-canopy cover, Los Angeles Basin watershed model, California.....	40
14.	Map showing vegetation type, Los Angeles Basin watershed model, California.....	42
15.	Map showing soil type, Los Angeles Basin watershed model, California.....	44
16.	Map showing rock types used as input for the Los Angeles Basin watershed model, California.....	46
17.	Map showing estimated soil thickness, Los Angeles Basin watershed model, California.....	48
18.	Map showing estimated thickness of bedrock-layer 6, Los Angeles Basin watershed model, California.....	50
19.	Map showing estimated root-zone storage capacity, Los Angeles Basin watershed model, California.....	51
20.	Map showing spatially distributed average January precipitation and climate stations with daily precipitation records used in the Los Angeles Basin watershed model, California.....	52
21.	Map showing spatially distributed average January minimum daily air temperature and climate stations with daily air-temperature records used in the Los Angeles Basin watershed model, California.....	53
22.	Map showing average snowfall estimated for water years 1915–2014 by using the Los Angeles Basin watershed model, California.....	54
23.	Map showing average annual estimated urban irrigation, Los Angeles Basin watershed model, California.....	57
24.	Graph showing average quarterly irrigation for 11 subdomains, Los Angeles Basin watershed model, California.....	58
25.	Map showing six streamflow-gaging stations used for model calibration, Los Angeles Basin watershed model, California.....	59

## Figures—Continued

26.	Graphs showing comparison of simulated and measured streamflow at gage COMP4, Los Angeles Basin watershed model, California: <i>A</i> , daily; <i>B</i> , monthly; <i>C</i> , annual.....	62
27.	Graphs showing comparison of simulated and measured streamflow at gage BALC6, Los Angeles Basin watershed model, California: <i>A</i> , daily; <i>B</i> , monthly; <i>C</i> , annual.....	64
28.	Graphs showing comparison of simulated and measured streamflow at gage COYC1, Los Angeles Basin watershed model, California: <i>A</i> , daily; <i>B</i> , monthly; <i>C</i> , annual.....	66
29.	Graphs showing comparison of simulated and measured streamflow at gage TOPG1, Los Angeles Basin watershed model, California: <i>A</i> , daily; <i>B</i> , monthly; <i>C</i> , annual.....	67
30.	Graphs showing comparison of simulated and measured streamflow at gage ALHW6, Los Angeles Basin watershed model, California: <i>A</i> , daily; <i>B</i> , monthly; <i>C</i> , annual.....	68
31.	Graphs showing comparison of simulated and measured streamflow at gage SJCE1, Los Angeles Basin watershed model, California: <i>A</i> , daily; <i>B</i> , monthly; <i>C</i> , annual.....	69
32.	Scatterplots of simulated against measured monthly streamflow, Los Angeles Basin watershed model, California, at gage <i>A</i> , BALC6; <i>B</i> , COMP4; <i>C</i> , COYC1; <i>D</i> , TOPG1; <i>E</i> , ALHW6; <i>F</i> , SJCE1 .....	70
33.	Scatterplots of simulated against measured annual streamflow at six gages used for model calibration, Los Angeles Basin watershed model, California: <i>A</i> , normal scale; <i>B</i> , log-scale .....	72
34.	Map showing average annual potential evapotranspiration simulated for water years 1915–2014 by using the Los Angeles Basin watershed model, California.....	74
35.	Map showing spatially distributed average annual evapotranspiration simulated for water years 1915–2014 by using the Los Angeles Basin watershed model, California .....	77
36.	Map showing simulated average streamflow for water years 1915–2014 by using the Los Angeles Basin watershed model, California .....	78
37.	Map showing spatially distributed average annual recharge simulated for water years 1915–2014 using the Los Angeles Basin watershed model, California .....	80
38.	Graphs showing annual simulation results for water years 1915–2014, Los Angeles Basin watershed model (LABWM), California: <i>A</i> , LABWM water-budget components; <i>B</i> , LABWM water-budget components as inflows and outflows; <i>C</i> , Los Angeles recharge-study area water-budget components; <i>D</i> , Los Angeles recharge-study area water-budget components as inflows and outflows; <i>E</i> , annual recharge for the LABWM domains; <i>F</i> , cumulative departure from mean annual recharge for the LABWM domains .....	81

## Figures—Continued

39.	Maps showing simulated annual recharge, Los Angeles basin watershed model, California, for <i>A</i> , water year 2005; and <i>B</i> , water year 2007.....	85
40.	Graphs showing average basin-wide monthly simulation results for water years 1915–2014, Los Angeles Basin watershed model, California: <i>A</i> , water-budget components; <i>B</i> , urban irrigation and recharge; <i>C</i> , inflows and outflows.....	87
41.	Map showing recharge areas for the Los Angeles groundwater study area, Los Angeles Basin watershed model, California.....	89
42.	Graphs showing annual and average monthly recharge simulated for the Los Angeles groundwater study area, Los Angeles Basin watershed model, California: <i>A</i> , direct and mountain-front recharge components; <i>B</i> , 5-year average annual direct recharge for groundwater basins; <i>C</i> , 5-year average annual recharge for mountain-front areas; <i>D</i> , average monthly recharge rate.....	90
43.	Map showing difference in simulation results, irrigated minus non-irrigated evapotranspiration for the Los Angeles recharge-study area, water years 1915–2014, Los Angeles Basin watershed model, California .....	95
44.	Map showing difference in simulation results, irrigated minus non-irrigated change in root-zone storage for the Los Angeles recharge-study area, water years 1915–2014, Los Angeles Basin watershed model, California .....	96
45.	Map showing the percentage difference for irrigated minus non-irrigated simulation simulated runoff for the Los Angeles recharge-study area, water years 1915–2014, Los Angeles Basin watershed model, California .....	97
46.	Map showing difference in results, irrigated minus non-irrigated simulated recharge for the Los Angeles recharge-study area, water years 1914–2015, Los Angeles Basin watershed model, California.....	98
47.	Graphs showing comparison of average monthly simulated recharge, Los Angeles Basin watershed model, California: <i>A</i> , average monthly recharge without irrigation; <i>B</i> , average monthly difference in recharge with and without urban irrigation; <i>C</i> , average monthly percentage increase in recharge with irrigation.....	99
48.	Graphs showing comparison of simulation results for subdomains by using a range of urban irrigation estimates, Los Angeles Basin watershed model, California: <i>A</i> , average 1915–2014 recharge; <i>B</i> , average 1915–2014 evapotranspiration .....	100
49.	Graphs showing comparison of simulation results for subdomains by using a range of urban irrigation estimates, Los Angeles Basin watershed model, California: <i>A</i> , percentage of contribution of urban irrigation to recharge; <i>B</i> , percentage of contribution of urban irrigation estimates to evapotranspiration .....	102
50.	Map showing internal and contributing recharge areas used for previous recharge estimates, Los Angeles Basin watershed model, California.....	103
51.	Graphs showing comparison of annual results from a previous study and results from using the Los Angeles Basin watershed model, California, for <i>A</i> , precipitation; and <i>B</i> , recharge .....	104
52.	Graph showing comparison of recoverable water with effective precipitation obtained with previous studies and with the Los Angeles Basin watershed model, California .....	105

## Tables

1.	Land-cover and land-use distributions for the Los Angeles Basin watershed model, California .....	7
2.	Climate stations and records used for estimating daily precipitation and maximum and minimum air temperature, Los Angeles Basin watershed model, California.....	8
3.	Average irrigation rates, in millimeters, estimated for 1,795 high-density single-family residential homes by using the minimum-month method, Los Angeles Basin watershed model, California .....	30
4.	Top 10 land-use classes (by area) of the San Fernando Valley, Los Angeles Basin watershed model, California .....	31
5.	Table of vegetation parameters (layers 1–6), Los Angeles Basin watershed model, California .....	43
6.	Table of soil parameters, model layers 1–5, Los Angeles Basin watershed model, California .....	45
7.	Geologic parameters (layers 6–7), Los Angeles Basin watershed model, California .....	47
8.	Atmospheric parameters, Los Angeles basin watershed model, California .....	56
9.	Streamflow-gaging stations and streamflow records used for model calibration, Los Angeles Basin watershed model, California.....	60
10.	Summary of model calibration results, Los Angeles Basin watershed model, California .....	63
11.	Summary of average inflows, outflows, and changes in storage for total model area and model subdomains, water years 1915–2014, Los Angeles Basin watershed model, California .....	75
12.	Summary of average inflows, outflows, and changes in storage for the Los Angeles groundwater basins and Los Angeles groundwater study area, water years 1915–2014, Los Angeles Basin watershed model, California .....	76
13.	Comparison of evapotranspiration and change in root-zone water-storage simulation results with and without urban irrigation, water years 1915–2014, Los Angeles Basin watershed model, California.....	92
14.	Comparison of recharge and streamflow simulation results with and without urban irrigation for water years 1915–2014, Los Angeles Basin watershed model, California .....	94
1–1.	Los Angeles Basin watershed model.....	114
2–1.	Los Angeles recharge study area .....	122
3–1.	Montebello Forebay .....	130
3–2.	Central Basin Pressure.....	137
3–3.	West Coast Basin .....	144
3–4.	Orange County.....	151
3–5.	Whittier area.....	158
3–6.	Los Angeles Forebay.....	165
3–7.	Hollywood .....	172
3–8.	Santa Monica .....	179
3–9.	Los Angeles groundwater study area .....	186

## Conversion Factors

International System of Units to U.S. customary units

<b>Multiply</b>	<b>By</b>	<b>To obtain</b>
Length		
millimeter (mm)	0.03937	inch (in.)
meter (m)	3.281	foot (ft)
Area		
square kilometer (km <sup>2</sup> )	247.1	acre
hectare (ha)	0.003861	square mile (mi <sup>2</sup> )
square kilometer (km <sup>2</sup> )	0.3861	square mile (mi <sup>2</sup> )
Volume		
cubic kilometer (km <sup>3</sup> )	0.2399	cubic mile (mi <sup>3</sup> )
cubic meter (m <sup>3</sup> )	0.0008107	acre-foot (acre-ft)
hectare meter (ha-m)	8.107	acre-foot (acre-ft)
Flow rate		
cubic meter per second (m <sup>3</sup> /s)	35.31	cubic foot per second (ft <sup>3</sup> /s)
hectare meter per year (ha-m/yr)	8.1103	acre-foot per year (acre-ft/yr)
millimeter per year (mm/yr)	0.03937	inch per year (in/yr)

Temperature in degrees Celsius (°C) may be converted to degrees Fahrenheit (°F) as  
 $^{\circ}\text{F} = (1.8 \times ^{\circ}\text{C}) + 32$ .

## Datum

Vertical coordinate information is referenced to North American Vertical Datum of 1988 (NAVD 88).

Horizontal coordinate information is referenced to the North American Datum of 1983 (NAD 83).

Elevation, as used in this report, refers to distance above the vertical datum.



## Abbreviations

BCM	Basin Characterization Model
DOD	U.S. Department of Defense
EPA	U.S. Environmental Protection Agency
ET	Evapotranspiration
GIS	Geographic Information System
LABWM	Los Angeles Basin watershed model
LACDWP	Los Angeles County Department of Power and Water
LAGSA	Los Angeles groundwater study area
NED	National Elevation Data
NSME	Nash-Sutcliffe model efficiency
PAEE	percent average estimation error
PET	potential evapotranspiration
PRISM	Parameter-elevation Regressions on Independent Slopes Model
PRMS	Precipitation Runoff Modeling System
STATSGO	State Soil Geographic Database
SWB	Soil Water Balance Model
USGS	U.S. Geological Survey
WRD	Water Replenishment District

This page intentionally left blank

# Estimating Spatially and Temporally Varying Recharge and Runoff from Precipitation and Urban Irrigation in the Los Angeles Basin, California

By Joseph A. Hevesi and Tyler D. Johnson

## Abstract

A daily precipitation-runoff model, referred to as the Los Angeles Basin watershed model (LABWM), was used to estimate recharge and runoff for a 5,047 square kilometer study area that included the greater Los Angeles area and all surface-water drainages potentially contributing recharge to a 1,450 square kilometer groundwater-study area underlying the greater Los Angeles area, referred to as the Los Angeles groundwater-study area. The recharge estimates for the Los Angeles groundwater-study area included spatially distributed recharge in response to the infiltration of precipitation, runoff, and urban irrigation, as well as mountain-front recharge from surface-water drainages bordering the groundwater-study area. The recharge and runoff estimates incorporated a new method for estimating urban irrigation, consisting of residential and commercial landscape watering, based on land use and the percentage of pervious land area.

The LABWM used a 201.17-meter gridded discretization of the study area to represent spatially distributed climate and watershed characteristics affecting the surface and shallow sub-surface hydrology for the Los Angeles groundwater study area. Climate data from a local network of 201 monitoring sites and published maps of 30-year-average monthly precipitation and maximum and minimum air temperature were used to develop the climate inputs for the LABWM. Published maps of land use, land cover, soils, vegetation, and surficial geology were used to represent the physical characteristics of the LABWM area. The LABWM was calibrated to available streamflow records at six streamflow-gaging stations.

Model results for a 100-year target-simulation period, from water years 1915 through 2014, were used to quantify and evaluate the spatial and temporal variability of water-budget components, including evapotranspiration (ET), recharge, and runoff. The largest outflow of water from the LABWM was ET; the 100-year average ET rate of 362 millimeters per year (mm/yr) accounted for 66 percent of the combined water inflow of 551 mm/yr, including

488 mm/yr from precipitation and 63 mm/yr from urban irrigation. The simulated ET rate varied from a minimum of 0 mm/yr for impervious areas to high values of more than 1,000 mm/yr for many areas, including the south-facing slopes of the San Gabriel Mountains, stream channels underlain by permeable soils and thick root zones, and pervious locations receiving inflows both from urban irrigation and surface water. Runoff was the next largest outflow, averaging 145 mm/yr for the 100-year period, or 26 percent of the combined precipitation and urban-irrigation inflow. Recharge averaged 45 mm/yr, or about 8 percent of the combined inflow from precipitation and urban irrigation.

Simulation results indicated that recharge in response to urban irrigation was an important component of spatially distributed recharge, contributing an average of 56 percent of the total recharge to the eight LABWM subdomains containing the Los Angeles groundwater study area. The 100-year average recharge rate for the eight subdomains was 41 mm/yr, or 8,473 hectare-meters per year (ha-m/yr), with urban irrigation included in the simulation compared to a recharge rate of 18 mm/yr, or 3,741 ha-m/yr, with urban irrigation excluded. In contrast to recharge, the effect of urban irrigation on runoff was slight; runoff was 72,667 ha-m/yr with urban irrigation included compared to 72,618 ha-m/yr with urban irrigation excluded, an increase of only 48 ha-m/yr (about 0.1 percent).

Simulation results also indicated that potential recharge from hilly drainages outside of, but bordering and tributary to, the lower-lying area of the Los Angeles groundwater study area, in this study referred to as mountain-front recharge, could provide an important contribution to the total recharge for the groundwater basins. The time-averaged recharge rate was similar to the combined direct and mountain-front recharge components estimated in a previous study and used as input for a calibrated groundwater model. The annual (water year) recharge estimates simulated in this study, however, indicated much greater year-to-year variability, which was dependent on year-to-year variability in the magnitude and distribution of daily precipitation, compared to the previous estimates.

## Introduction

The Water Replenishment District (WRD) of Southern California is the groundwater-management agency responsible for the availability of a safe and reliable supply of groundwater for a 109,773 hectare (ha) management area in southern coastal Los Angeles County (Water Replenishment District of Southern California, 2013; fig. 1). Through the 20th century, historical development of groundwater basins in the greater Los Angeles area, including the WRD management area, caused large water-level declines and induced seawater intrusion (Reichard and others, 2003). To mitigate water-level declines and seawater intrusion, numerous groundwater-management activities were implemented in the latter part of the 20th century, including increased surface-water spreading for induced recharge, construction of groundwater-injection barriers, increased delivery of imported water, and increased use of reclaimed water (Reichard and others, 2003).

In order to improve the scientific basis for the water-management activities of the WRD, the U.S. Geological Survey (USGS), in cooperation with the WRD, developed a groundwater-flow and optimization model for a 167,316-ha study area in southern Los Angeles County, including most of the WRD management area (Reichard and others, 2003; fig. 1A). As part of the development of the groundwater model, the land area in the groundwater-study area was partitioned into seven groundwater basins on the basis of hydrogeologic studies and well data: (1) Central Basin Pressure, (2) Hollywood, (3) Los Angeles (LA) Forebay, (4) Montebello Forebay, (5) Santa Monica, (6) West Coast Basin, and (7) Whittier Area (Reichard and others, 2003). The boundaries of the seven groundwater basins were modified during subsequent groundwater studies by the USGS, done in cooperation with the WRD (Claudia Faunt and Scott Paulinski, U.S. Geological Survey, written commun., June 2015). In addition to these modifications an area referred to as the Orange County groundwater basin was added to the groundwater study area because the area of interest for groundwater studies was extended southeastward into northwestern Orange County (Claudia Faunt and Scott Paulinski, U.S. Geological Survey, written commun., June 2015). The 149,968-ha area defined by these eight groundwater basins is referred to as the Los Angeles groundwater study area (LAGSA; fig. 1A).

Recharge is an important component of the hydrologic system of the LAGSA that needs to be defined as part of the development of groundwater-flow models and to quantify the water budget. Recharge to the LAGSA includes natural and anthropogenic (artificially induced) components. Natural recharge includes recharge from infiltration of precipitation (rainfall and snowmelt) and surface-water runoff. Recharge from infiltration of streamflow in the larger channels is limited because most of the larger stream channels were lined with concrete (Reichard and others, 2003). The Los Angeles River was lined along its entire extent in the LAGSA, except just upstream from where it enters San Pedro Bay. The San Gabriel

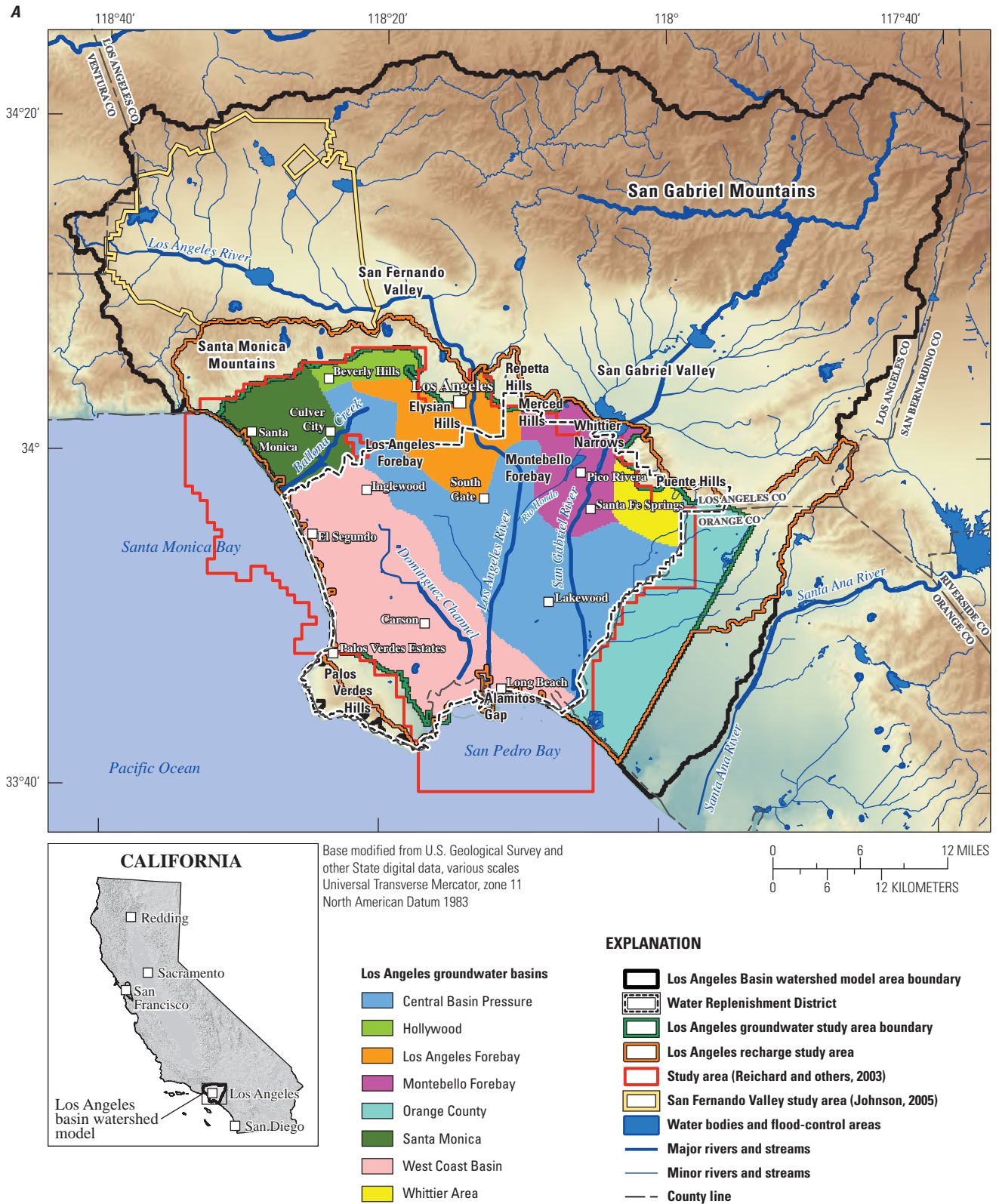
River was lined, except in the upper parts of the Montebello Forebay and near the Alamitos Gap, and the Rio Hondo was lined its entire extent in the LAGSA.

For the 100-year period considered in this study, from water year 1915 through water year 2014, much of the recharge was anthropogenic. Anthropogenic recharge includes two types: (1) artificially induced or enhanced recharge from spreading grounds, retention basins, and injection wells, and (2) return flows from irrigation and leakage from water and sewer lines. A major source of anthropogenic, artificially induced recharge to the LAGSA is the diversion of storm runoff and imported water from the Rio Hondo and San Gabriel River stream channels to the spreading ponds next to the stream channels in the Whittier Narrows area along the northeastern boundary of the LAGSA, upstream from the Montebello Forebay (Reichard and others, 2003). A second important source of anthropogenic, artificially induced recharge is from injection wells in the western and southwestern parts of the LAGSA.

The LAGSA is hydraulically linked to three adjacent basins: the San Fernando Valley to the north, the San Gabriel Valley to the northeast, and the Orange County Basin to the southeast. In addition to these three adjacent basins, recharge from streams with unlined channels in smaller drainages along the periphery of the LAGSA could contribute to mountain-front recharge. In this study, mountain-front recharge to a groundwater basin refers to lateral inflows of groundwater that originates as recharge in surface-water drainages upstream from the groundwater basin and peripheral to the boundary of the groundwater basin. Peripheral drainages potentially contributing to recharge to the LAGSA are along the northern, northeastern, and southwestern boundary of the LAGSA (Reichard and others, 2003). For this study, the total area contributing recharge to the LAGSA, including the LAGSA and peripheral drainages bordering the LAGSA, is referred to as the Los Angeles recharge-study area (fig. 1).

## Purpose and Scope

The purpose of this report is to document the development, calibration, and application of the Los Angeles Basin watershed model (LABWM). The primary purpose of the LABWM was to estimate spatially and temporally distributed recharge to the LAGSA in response to precipitation and runoff, as well as recharge in response to urban irrigation, by using a distributed-parameter, daily precipitation-runoff model called the LABWM. The LABWM was also used to quantify components of the water budget, including spatially and temporally distributed runoff in response to daily precipitation and urban irrigation. The LABWM was developed by using the INFILv3 watershed-modeling code (U.S. Geological Survey, 2008) with a modification to include quarterly estimates of urban-area landscape irrigation, added to the daily precipitation input as a spatially distributed daily urban irrigation rate. Application of the modified precipitation-runoff model allowed for the simulation of the natural



**Figure 1.** Los Angeles Basin watershed model (LABWM) area, southern California: *A*, Los Angeles groundwater basins and related study areas; *B*, major surface-water drainages.



4 Estimating Spatially and Temporally Varying Recharge and Runoff from Precipitation and Urban Irrigation

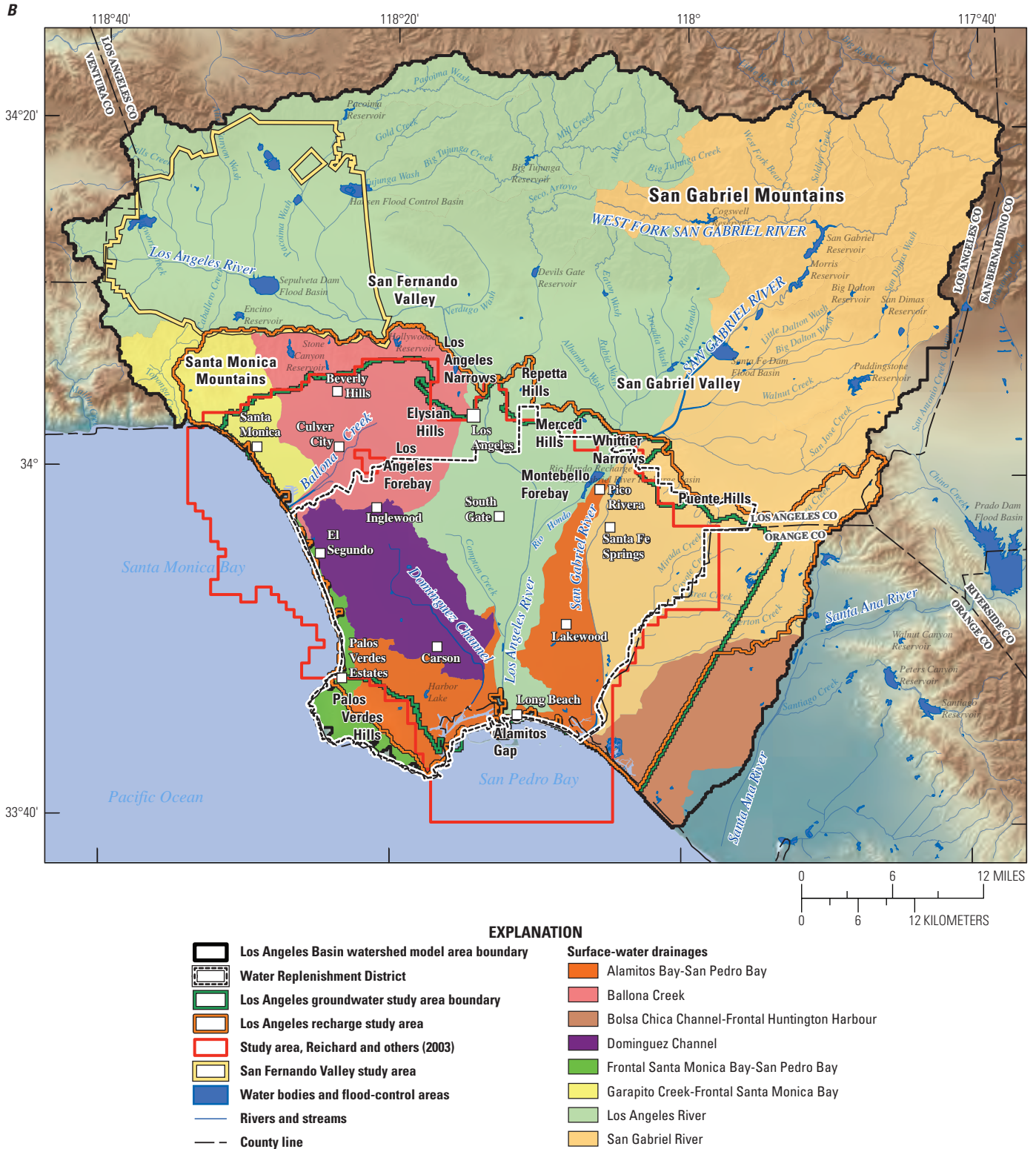


Figure 1. —Continued

recharge component and the urban return flow component of anthropogenic recharge resulting from urban irrigation. A distributed-parameter model was used to improve the representation of spatial variability in natural recharge and recharge in response to urban irrigation. The precipitation-runoff model was applied by using the available climate data for a 110-year simulation period starting with water year 1905 and ending with water year 2014. The simulation period included a 10-year model-initialization period (water years 1905–14) and a 100-year target-simulation period (water years 1915–2014). The 100-year simulation period was used to evaluate the temporal variability of recharge and runoff in response to temporal variability in climate and to develop estimates of the long-term water budget.

This study accounts only for natural recharge in response to precipitation and runoff and anthropogenic recharge in response to urban landscape irrigation. Although induced recharge from retention basins, spreading grounds, and injection wells are significant sources of recharge for the LAGSA, these recharge sources are documented and quantified by the WRD of Southern California, and, therefore, did not require estimation or simulation as part of the ongoing groundwater flow modeling studies.

## Description of Study Area

The study area for this report is defined by the boundary of the LABWM area (fig. 1). The LABWM area is 5,047 square kilometers (km<sup>2</sup>), which includes most of southern Los Angeles County, the northwestern part of Orange County, a small area of westernmost San Bernardino County, and a small area of easternmost Ventura County. The LABWM area was defined on the basis of the need to include all surface-water drainages that have potential to contribute to natural recharge and runoff in response to climate as well as urban-irrigation induced recharge and runoff for the LAGSA.

The LABWM area is drained by three main rivers: (1) the Los Angeles River, with a drainage area of 2,142 km<sup>2</sup>; (2) the San Gabriel River, with a drainage area of 1,850 km<sup>2</sup>; and (3) Ballona Creek, with a drainage area of 340 km<sup>2</sup> (fig. 1B). Additional drainages and hydrographic areas in the LABWM area include the Dominguez Channel drainage (214 km<sup>2</sup>), the Garapito Creek–frontal Santa Monica Bay hydrographic area (334 km<sup>2</sup>), the frontal Santa Monica Bay–San Pedro Bay hydrographic area (301 km<sup>2</sup>), the Alamitos Bay–San Pedro Bay hydrographic area (428 km<sup>2</sup>), and the Bolsa Chica Channel–Huntington Harbor hydrographic area (330 km<sup>2</sup>; fig. 1B). The upper Los Angeles River, which drains the San Fernando Valley to the north, enters the LAGSA through the Los Angeles Narrows. The San Gabriel River and Rio Hondo (a major tributary of the Los Angeles River), which drain the San Gabriel Mountains and the San Gabriel Valley to the northeast, both enter the LAGSA through the Whittier Narrows. The Santa Ana River, the largest drainage in the southern California region, runs along the southeastern boundary of the LABWM area. Most of the larger rivers in the

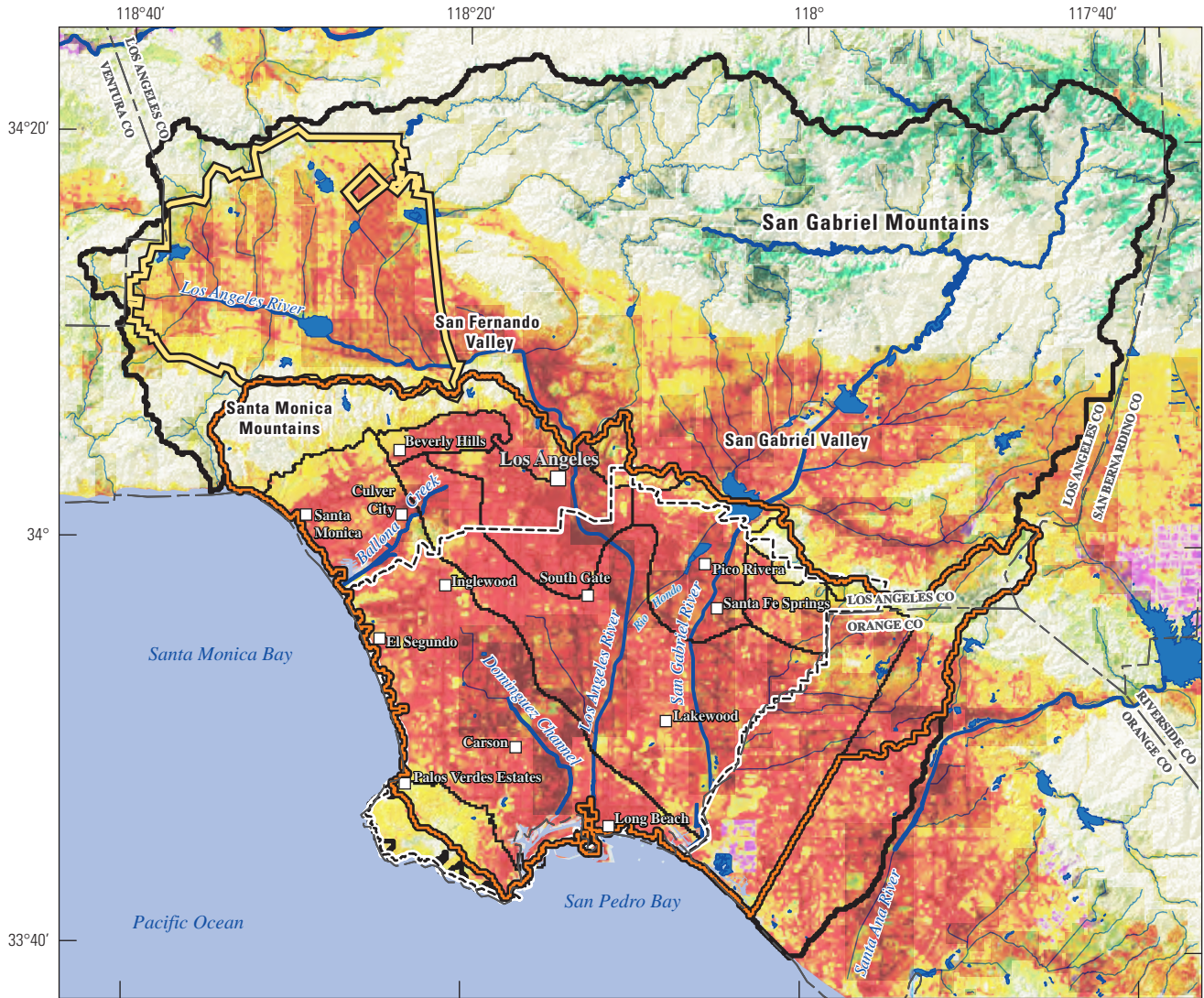
LABWM area are managed by flow diversions, reservoirs, and spreading grounds (Reichard and others, 2003). Natural stream channels exist primarily in the mountainous areas, whereas in the developed areas, most of the streamflow is routed through a system of engineered channels and storm drains.

Although the upper parts of the Los Angeles, San Gabriel River and Rio Hondo watersheds probably do not contribute much recharge to the LAGSA, these areas were included in the LABWM area for completeness in terms of simulating the surface-water drainages potentially affecting the LAGSA. The larger model area allowed for a more comprehensive representation of the watershed areas potentially contributing recharge to the LAGSA, including areas outside of the area of the peripheral drainages included in the Los Angeles recharge-study area (fig. 1). The inclusion of the complete watersheds for the Los Angeles River, the San Gabriel River, and the Rio Hondo, also incorporated the complete drainage areas upstream from some of the streamflow-gaging stations used for model calibration.

The LABWM area is bounded by the crest of the San Gabriel Mountains to the north, the Pacific Ocean to the west and south, Orange County to the southeast, and San Bernardino County to the east (fig. 1). The northeastern part of the LABWM area includes the more rugged terrain of the San Gabriel Mountains, with elevations ranging from 1,000 to 3,505 meters (m), and land cover consisting mostly of natural vegetation (fig. 2). The northwestern part of the LABWM area includes the rugged terrain of the Santa Monica Mountains, with elevations from 200 to 1,000 m, and also includes land cover consisting primarily of natural vegetation. In contrast to the mountainous areas, low-lying areas in the LABWM area, including the Los Angeles coastal plain in the southern part (with elevations for most areas varying from sea level to 100 m), the San Fernando Valley in the northwestern part (with elevations varying from 200 to 500 m), and the San Gabriel Valley in the east-central part (with elevations varying from 70 to 350 m), are generally highly urbanized areas (figs. 1, 2). Although agricultural land uses composed a large percentage of the developed-land areas within the LABWM area in the earlier 1900s, developed-land areas from the mid-1900s onward consist primarily of medium-to-high density residential, commercial, and industrial land uses (Reichard and others, 2003). In more recent times (calendar year 2001), developed-land areas (including open space and low-, medium-, and high-density developed areas) covered 3,225 km<sup>2</sup> in the LABWM area, or about 64 percent of the total land area (table 1). Compared to the LABWM area in 2001, the Los Angeles recharge-study area and the LAGSA had much greater percentages of land cover consisting of developed areas in 2001; developed-land areas covered 90 percent (1,694 km<sup>2</sup>) of the Los Angeles recharge-study area and 97 percent (1,453 km<sup>2</sup>) of the LAGSA (table 1). For all areas, the developed areas consisted mostly of medium-density developed land. Forested lands covered 7 percent (344 km<sup>2</sup>) of the LABWM area, compared to 1 percent (17 km<sup>2</sup>) for the Los Angeles recharge-study area and about 0 percent (2 km<sup>2</sup>)



6 Estimating Spatially and Temporally Varying Recharge and Runoff from Precipitation and Urban Irrigation



Base modified from U.S. Geological Survey and other Federal and State digital data, various scales  
 Universal Transverse Mercator, zone 11  
 North American Datum 1983



Dominant land-cover types (2001)		EXPLANATION	
	Ocean		Emergent herbaceous wetlands
	Barren land		Evergreen forest
	Cultivated crops		Grassland and herbaceous
	Deciduous forest		Mixed forest
	Developed, high intensity		Open water
	Developed, medium intensity		Pasture and hay
	Developed, low intensity		Shrub and scrub
	Developed, open space		Woody wetlands
			Los Angeles Basin watershed model area boundary
			Water Replenishment District
			Los Angeles groundwater study area boundary
			Los Angeles recharge study area
			San Fernando Valley study area
			Water bodies and flood-control areas
			Major rivers and streams
			Minor rivers and streams
			Los Angeles groundwater basins
			County line

Figure 2. Land cover and land use for the Los Angeles Basin watershed model (LABWM) area, southern California region, California.



**Table 1.** Land-cover and land-use distributions for the Los Angeles Basin watershed model (LABWM), California.[km<sup>2</sup>, square kilometer]

2001 land cover and land use	Los Angeles Basin watershed model area		Los Angeles recharge study area		Los Angeles groundwater study area	
	Area (km <sup>2</sup> )	Total area (percent)	Area (km <sup>2</sup> )	Total area (percent)	Area (km <sup>2</sup> )	Total area (percent)
Open water	20	0	13	1	9	1
Developed, open space	482	10	157	8	79	5
Developed, low intensity	725	14	250	13	187	12
Developed, medium intensity	1,495	30	873	46	793	53
Developed, high intensity	522	10	415	22	393	26
Barren land (rock/sand/clay)	14	0	3	0	3	0
Deciduous forest	0	0	0	0	0	0
Evergreen forest	281	6	6	0	1	0
Mixed forest	63	1	12	1	1	0
Shrub/scrub	1,286	25	109	6	4	0
Grassland/herbaceous	139	3	42	2	20	1
Pasture/hay	2	0	0	0	0	0
Cultivated crops	7	0	6	0	6	0
Woody wetlands	5	0	1	0	1	0
Emergent herbaceous wetlands	5	0	2	0	2	0
Total land cover	5,048	100	1,887	100	1,500	100
Total developed land cover	3,225	64	1,694	90	1,453	97
Total natural vegetation cover	1,780	35	171	9	29	2
Natural forest cover	344	7	17	1	2	0

for the LAGSA. For the LABWM area and the Los Angeles recharge-study area, shrubland was the dominant natural vegetation cover in 2001, whereas grassland was the dominant natural vegetation for the LAGSA. For all areas, open water covered 1 percent or less of the land area in 2001.

Variations in the timing, frequency, amount, and spatial distribution of precipitation are important factors affecting the natural hydrologic system. Spatial and temporal variations in air temperature, as well as diurnal variations between maximum and minimum daily temperature, are also critical factors because air temperature affects the available energy for evapotranspiration and the type of precipitation (rain or snow). Higher elevations are generally colder and wetter compared to the low-lying coastal plane and interior valleys. Inland locations are generally hotter during the summer and colder during the winter compared to locations along the coastline.

Average monthly precipitation for the LABWM area was estimated for water years 1915–2014 by using a modified inverse-distance-squared spatial-interpolation method (Hevesi and Christensen, 2015; Flint and Martin, 2012) that incorporates the Parameter-elevation Regressions on Independent Slopes Model (PRISM) 30-year (1971–2000) normal precipitation map (Daly and others, 2004) and daily precipitation records from a network of 201 climate stations distributed throughout the LABWM area (table 2). PRISM

accounts for various factors affecting the spatial distribution of precipitation, including topography, average storm track, and distance from moisture sources (Daly and others, 2004). The PRISM results are commonly used to develop climate inputs for watershed models (Hevesi and others, 2011; Flint and Martin, 2012; Woolfenden and Nishikawa, 2014; Hevesi and Christensen, 2015). The modified inverse-distance-squared spatial-interpolation method uses the PRISM estimates, available as 800-meter gridded national maps, and the 201 daily precipitation records to develop estimates of spatially distributed daily precipitation for the entire LABWM area (Hevesi and others, 2011; Woolfenden and Nishikawa, 2014; Hevesi and Christensen, 2015). The results indicated that precipitation falls primarily during the cooler months of October through May (fig. 3A). For most of the LABWM area, February was the wettest month, averaging 123 millimeters (mm) for the entire LABWM area and varying from 287 mm for the wettest location, in the San Gabriel Mountains, to 70 mm for the driest, in the southern coastal part of the LABWM area. January and March were the second and third wettest months, respectively, with both months averaging more than 100 mm precipitation in the LABWM area. July was the driest month, averaging 0.6 mm for the entire LABWM area and ranging from 7.6 mm to 0 mm in the LABWM area.

**Table 2.** Climate stations and records used for estimating daily precipitation and maximum and minimum air temperature, Los Angeles Basin watershed model (LABWM), California.

[m, meter; mm, millimeter; NAD83, North American Datum of 1983; NCDC, National Climate Data Center; RAWS, Remote Automated Weather System; UTM, Universal Transverse Mercator; °C, degrees Celsius; —, not available]

Station name	Map number	Data source	Station code	Station location		Station elevation (m)	Daily precipitation records				
				UTM 11 (NAD83) Easting (m)	UTM 11 (NAD83) Northing (m)		Start year	End year	Years of record	Average (mm)	Maximum (mm)
ACTON ESCONDIDO FC261	1	NCDC	40014	383,187	3,817,743	905	1948	2010	56.4	269.9	102.1
ADELANTO	2	NCDC	40024	461,703	3,826,913	869	1959	1977	17.1	91.4	66.6
ALISO CANYON OAT MTN F	3	NCDC	40115	357,303	3,798,361	722	1948	1990	40.5	536.4	215.9
ALTADENA	4	NCDC	40144	395,019	3,782,912	344	1949	2010	57.6	556.8	201.9
ANAHEIM	5	NCDC	40192	421,990	3,747,476	102	1989	2010	20.6	360.4	170.9
ARROYO SECO RNG STN FC	6	NCDC	40327	392,446	3,786,800	372	1948	1974	25.6	520.6	224.5
ASSOC OIL ANAHEIM 1	7	NCDC	40355	418,250	3,751,422	104	1948	1966	16.7	291.6	109
AVALON PLEASURE PIER	8	NCDC	40395	377,399	3,690,867	8	1948	1988	39.3	300.9	149.6
AZUSA CITY PARK FC 143	9	NCDC	40410	416,933	3,777,304	186	1949	1972	23.6	432.3	227.3
BARNESON PARK	10	NCDC	40509	421,360	3,755,088	177	1948	1966	15.8	342.7	177.8
BEL AIR FC 10A	11	NCDC	40619	366,137	3,772,343	165	1948	1980	32	460	155.4
BELL CANYON PLATT RCH	12	NCDC	40625	347,891	3,785,564	281	1948	1951	3.1	195.7	48
BENNETT RCH	13	NCDC	40678	458,443	3,780,732	564	1948	1953	4.7	645.1	125.7
BIG DALTON DAM FC223C	14	NCDC	40758	424,644	3,780,942	485	1949	1980	30.6	610.5	283
BIG PINES PARK FC83B	15	NCDC	40779	437,101	3,804,869	2,086	1948	1996	47.2	631.9	240.3
BIG TUJUNGA DAM FC46	16	NCDC	40798	390,658	3,795,416	709	1949	2010	56.2	640	292.6
BIRMINGHAM GEN HOSP	17	NCDC	40818	361,686	3,783,499	220	1948	1951	3.1	162.7	33.8
BOUQUET CANYON	18	NCDC	41013	374,569	3,827,683	933	1948	1978	29.5	378.8	122.2
BREA BERRY & IMPERI	19	NCDC	41054	416,722	3,753,287	107	1948	1959	10.8	345.1	115.8
BREA CY SHAFFER TOOL W	20	NCDC	41056	416,738	3,755,127	116	1957	1970	12	344.7	88.4
BREA DAM	21	NCDC	41057	414,255	3,750,415	84	1948	1960	12.4	298.4	100.1
BURBANK FIRE DEP FC226	22	NCDC	41192	380,119	3,783,246	207	1949	1972	23.8	369.1	142
BURBANK VLY PUMP PLT	23	NCDC	41194	375,691	3,783,680	200	1939	2010	70	419.2	197.1
CAJON WEST SUMMIT	24	NCDC	41272	445,453	3,805,559	1,457	1948	1951	3.1	89.2	23.6
CAMP BALDY FC 85 F	25	NCDC	41373	438,518	3,788,227	1,312	1948	1958	9.9	691.6	230.9
CAMP HILL OPIDS 57B	26	NCDC	41404	398,631	3,790,425	1,296	1969	1978	9.4	931.9	326.1
CANOGA PARK PIERCE CLG	27	NCDC	41484	354,827	3,783,447	241	1949	2006	56.8	429.6	166.9
CARBON CANYON WORKMAN	28	NCDC	41520	427,924	3,757,786	360	1949	1951	2.1	283.4	68.1
CHATSWORTH HEYNE MANN R	29	NCDC	41679	352,615	3,792,888	305	1948	1959	11.1	430.2	130.3
CHATSWORTH FC 24 F	30	NCDC	41680	352,586	3,791,036	290	1949	1988	37.9	408.3	148.6

**Table 2.** Climate stations and records used for estimating daily precipitation and maximum and minimum air temperature, Los Angeles Basin watershed model (LABWM), California.—Continued

[m, meter; mm, millimeter; NAD83, North American Datum of 1983; NCDC, National Climate Data Center; RAWS, Remote Automated Weather System; UTM, Universal Transverse Mercator; °C, degrees Celsius; —, not available]

Station name	Map number	Data source	Station code	Station location		Station elevation (m)	Daily precipitation records				
				UTM 11 (NAD83) Easting (m)	UTM 11 (NAD83) Northing (m)		Start year	End year	Years of record	Average (mm)	Maximum (mm)
CHATSWORTH RSVR	31	NCDC	41682	350,988	3,788,443	277	1948	1951	3.1	216.1	37.3
CLAREMONT FC 230 D	32	NCDC	41777	432,291	3,775,340	381	1961	1963	2.7	318.8	75.4
CLAREMONT POMONA CLG	33	NCDC	41779	433,809	3,773,477	366	1948	1980	30.7	405.7	176.5
COLBYS FC 53D	34	NCDC	41896	397,154	3,795,986	1,122	1955	1978	23.9	653.9	302.5
CORONA	35	NCDC	42031	449,057	3,749,355	186	1948	1988	40.1	291.3	93
COVINA	36	NCDC	42088	419,941	3,769,892	183	1948	1949	0.9	323.7	40.6
COVINA CITY YRD FC387B	37	NCDC	42090	418,682	3,772,697	178	1949	2010	57	458.7	165.9
CRESTLINE	38	NCDC	42162	472,296	3,789,918	1,485	1948	1951	2.7	667.4	133.9
CRYSTAL LAKE FC238C	39	NCDC	42198	422,561	3,797,715	1,637	1959	2010	43.1	901.5	296.2
CRYSTAL LK EAST PINE F	40	NCDC	42199	423,265	3,799,428	1,760	1955	1959	4.7	805.8	165.6
CULVER CITY	41	NCDC	42214	369,450	3,763,613	17	1935	2010	72.2	333.1	114.3
DIAMOND BAR	42	NCDC	42432	426,039	3,762,446	268	1948	1951	3.2	248.3	62
DOWNEY FIRE DEPT FC107C	43	NCDC	42494	394,033	3,754,955	34	1949	2010	55.8	369.5	136.4
DRY CANYON RSVR	44	NCDC	42516	359,120	3,816,813	444	1948	1990	39.2	331.9	158
EAST PINE FLAT	45	NCDC	42643	423,265	3,799,428	1,751	1949	1954	5.8	670	268.2
EAST WHITTIER	46	NCDC	42655	404,455	3,758,947	67	1949	1950	1.5	280.2	43.2
ELIZABETH LAKE CN FC12	47	NCDC	42735	356,253	3,829,802	634	1955	1972	17.8	535.4	156.5
EL MIRAGE	48	NCDC	42771	442,116	3,827,669	899	1971	2010	37.9	146.5	62.2
EL MODENA	49	NCDC	42775	427,412	3,740,259	140	1948	1951	3.2	223.5	47
ELSINORE	50	NCDC	42805	469,151	3,725,531	392	1948	2010	59.4	290.3	121.9
ETIWANDA	51	NCDC	42895	451,612	3,776,884	424	1948	1951	3.1	297.5	83.6
FILLMORE 1 WNW	52	NCDC	43050	322,207	3,808,204	134	1959	1977	17.7	451.4	146.1
FONTANA 5 N	53	NCDC	43118	458,452	3,782,573	601	1953	1984	31.5	649.9	273.3
FONTANA KAISER	54	NCDC	43120	452,249	3,771,514	336	1951	1984	33.1	391.7	154.2
FULLERTON ARROUES RCH	55	NCDC	43279	415,162	3,751,449	98	1948	1965	16.5	305.1	124.7
FULLERTON CREEK 5	56	NCDC	43282	419,800	3,753,260	122	1948	1958	10.1	327.7	218.4
FULLERTON DAM	57	NCDC	43285	417,803	3,751,026	104	1948	1960	11.6	304.2	113
FULLERTON HILLCREST RE	58	NCDC	43288	415,145	3,749,597	101	1945	1976	26.9	313.2	131.1
GETTY CTR	59	NCDC	43392	363,504	3,772,780	336	2000	2010	10	434.5	110.2
GIRARD BRANT RCH	60	NCDC	43430	352,441	3,781,798	268	1949	1952	3.6	312.5	101.6

**Table 2.** Climate stations and records used for estimating daily precipitation and maximum and minimum air temperature, Los Angeles Basin watershed model (LABWM), California.—Continued

[m, meter; mm, millimeter; NAD83, North American Datum of 1983; NCDC, National Climate Data Center; RAWS, Remote Automated Weather System; UTM, Universal Transverse Mercator; °C, degrees Celsius; —, not available]

Station name	Map number	Data source	Station code	Station location			Station elevation (m)	Daily precipitation records			
				UTM 11 (NAD83) Easting (m)	UTM 11 (NAD83) Northing (m)	Start year		End year	Years of record	Average (mm)	Maximum (mm)
GLENDALE STAPENHORST F	61	NCDC	43450	383,142	3,779,514	162	1949	1971	22.7	401.8	153.9
GLENDORA FC 287B	62	NCDC	43452	421,814	3,778,714	280	1949	2010	57.7	546.1	196.3
HAINES CAN LWR FC 364	63	NCDC	43703	383,303	3,792,455	747	1949	1970	21.2	558.1	238
HAINES CNYN UPR FC367	64	NCDC	43704	384,840	3,792,436	1,049	1949	1979	29.7	641.8	253.5
HANSEN DAM	65	NCDC	43751	372,273	3,791,945	331	1948	1960	12	277.7	94.7
HESPERIA	66	NCDC	43935	472,351	3,808,402	976	1959	1977	18	163.5	61
HOEGEES FC 60 A	67	NCDC	44017	404,735	3,786,668	808	1949	1978	28.9	807.3	360.2
IRVINE RCH	68	NCDC	44303	432,922	3,731,348	165	2003	2010	6.9	351.1	102.1
LA BREA CANYON HUNT	69	NCDC	44620	422,918	3,756,927	214	1948	1955	7.1	352.7	160
LA CRESCENTA FC251 C	70	NCDC	44628	385,470	3,787,493	471	1949	2010	57	595.9	217.9
LAGUNA BEACH	71	NCDC	44647	427,374	3,712,018	13	1928	2008	78.6	323	139.7
LAGUNA BEACH #2	72	NCDC	44650	425,601	3,713,296	64	1948	1951	3.2	144	21.3
LA VERNE HTS FC 560 B	73	NCDC	44840	430,751	3,775,351	369	1963	1972	9	447.1	107.4
LECHUZA PTRL ST FC352B	74	NCDC	44867	326,417	3,772,225	488	1948	1997	48.8	548.5	186.7
LITTLE TUJUNGA GLD CR	75	NCDC	44986	380,308	3,798,038	839	1948	1951	2	305.3	65.5
LIVE OAK CANYON FC 230	76	NCDC	44993	432,291	3,775,340	383	1949	1960	11.7	414	178.3
LLANO SHAWNEE HILLS RC	77	NCDC	45002	431,037	3,814,160	1,165	1948	1965	17	168.2	64.8
LONG BEACH AQUARIUM	78	NCDC	45080	389,074	3,736,314	6	1970	1973	3.1	242.8	76.2
LONG BEACH PUB SVC	79	NCDC	45082	388,794	3,736,938	9	1927	1969	41.8	321.1	170.4
LONG BCH DAUGHERTY AP	80	NCDC	45085	393,813	3,741,872	10	1958	2010	52.7	306.2	95.3
LOS ANGELES 6TH MAIN	81	NCDC	45111	384,546	3,768,407	125	1948	1951	3.2	198.7	46.7
LOS ANGELES TERMINAL A	82	NCDC	45112	386,110	3,770,240	85	1948	1953	5.3	332.7	91.2
LOS ANGELES INTLAP	83	NCDC	45114	371,556	3,756,164	30	1944	2010	66.4	307.4	142.2
LOS ANGELES DWTN USC	84	NCDC	45115	380,685	3,765,316	52	1948	2010	62.2	370.5	145
LYTLE CK FTHILL BLVD	85	NCDC	45212	469,045	3,772,742	354	1948	1951	3.2	221.5	40.9
LYTLE CREEK PH	86	NCDC	45215	458,460	3,784,425	686	1948	1967	19.1	687.1	247.4
LYTLE CREEK RS	87	NCDC	45218	456,563	3,788,680	832	1948	2001	52.1	881.2	548.9
MAGIC MTN	88	NCDC	45256	381,961	3,807,256	1,357	1948	1951	2.6	386.7	62.2
MARCH FLD	89	NCDC	45326	476,796	3,747,406	454	1948	1964	15.5	213.5	58.7
MONROVIA	90	NCDC	45781	407,730	3,779,241	171	1952	1953	1.1	260	31

**Table 2.** Climate stations and records used for estimating daily precipitation and maximum and minimum air temperature, Los Angeles Basin watershed model (LABWM), California.—Continued

[m, meter; mm, millimeter; NAD83, North American Datum of 1983; NCDC, National Climate Data Center; RAWS, Remote Automated Weather System; UTM, Universal Transverse Mercator; °C, degrees Celsius; —, not available]

Station name	Map number	Data source	Station code	Station location		Station elevation (m)	Daily precipitation records				
				UTM 11 (NAD83) Easting (m)	Northing (m)		Start year	End year	Years of record	Average (mm)	Maximum (mm)
MONTEBELLO	91	NCDC	45790	397,995	3,764,837	73	1979	2010	28.6	362.2	177.8
MOORPARK	92	NCDC	45823	326,564	3,795,176	177	1956	1977	21.2	336.7	140.7
MT BALDY FC 85 G	93	NCDC	45900	440,056	3,788,217	1,305	1958	1976	18.2	776.4	314.5
MT BALDY NOTCH	94	NCDC	45901	443,157	3,793,742	2,361	1961	1972	8.2	1043.6	384.8
MT WILSON CBS	95	NCDC	46006	401,269	3,788,267	1,740	1948	2010	60.8	855.7	303.8
NEWBURY PARK 4 SW	96	NCDC	46149	318,600	3,780,538	238	1956	1971	13.4	415.1	129.5
NEWHALL AP	97	NCDC	46159	357,444	3,807,599	370	1948	1949	1.2	178.3	26.2
NEWHALL 5NW	98	NCDC	46161	353,397	3,806,918	538	1997	2010	13.3	451.2	195.1
NEWHALL S FC32CE	99	NCDC	46162	358,875	3,806,124	379	1949	2001	48.9	440.7	168.1
NEWHALL US RS	100	NCDC	46164	360,450	3,803,859	409	1949	1951	1.8	225.9	41.2
NEWHALL	101	NCDC	46165	355,852	3,803,929	427	1989	1997	7.7	480.5	127
NEWPORT BEACH HARBOR	102	NCDC	46175	418,246	3,718,434	3	1934	2010	74.1	283	152.4
NORTH HOLLYWOOD	103	NCDC	46256	372,417	3,781,506	189	1948	1962	13.6	338.8	130.8
NORTHRIDGE CAL STATE	104	NCDC	46263	359,012	3,789,617	261	1998	2010	11.7	348.2	111.8
OLINDA	105	NCDC	46432	421,344	3,753,247	149	1948	1966	17.7	314.8	108.2
OPIDS CAMP FC 57 BE	106	NCDC	46465	398,631	3,790,425	1,296	1948	1969	18.9	948.4	395.2
ORANGE CO RSVR	107	NCDC	46473	418,129	3,755,614	201	1948	1951	3.1	215.7	47
OXNARD	108	NCDC	46569	299,479	3,786,263	15	1948	2002	53.7	373.9	151.4
OXNARD WSFO	109	NCDC	46572	302,892	3,787,666	19	1998	2010	11.9	373.8	100.6
PACIFIC COLOGE FC 356B	110	NCDC	46594	424,540	3,768,003	210	1948	1954	6.4	350.6	102.6
PACOIMA DAM FC 33 A-E	111	NCDC	46602	371,185	3,799,912	457	1949	2010	58.3	497	145.8
PALMDALE	112	NCDC	46624	399,569	3,827,877	791	1931	2010	78.6	197.5	87.1
PALMDALE FAA AP	113	NCDC	46627	400,623	3,832,912	767	1948	1974	25.7	130.9	64
PALOS VERDES ES FC43D	114	NCDC	46663	371,145	3,740,820	66	1949	2010	55.6	319.2	113
PASADENA	115	NCDC	46719	394,388	3,779,193	263	1927	2010	82.4	518	195.6
PEARBLOSSOM	116	NCDC	46773	417,727	3,818,238	930	1985	2010	24.1	175.9	77.7
PERRIS	117	NCDC	46816	478,320	3,738,156	448	1961	1973	11.2	268.8	105.9
PERRIS 1 WSW	118	NCDC	46818	476,774	3,738,160	488	1951	1957	5.6	291.5	56.6
PIRU 2 ESE	119	NCDC	46940	338,537	3,808,584	223	1959	2010	49	472.1	172.7
POMONA FAIRPLEX	120	NCDC	47050	429,283	3,771,414	317	1927	2010	75.4	438.7	215.9

**Table 2.** Climate stations and records used for estimating daily precipitation and maximum and minimum air temperature, Los Angeles Basin watershed model (LABWM), California.—Continued

[m, meter; mm, millimeter; NAD83, North American Datum of 1983; NCDC, National Climate Data Center; RAWS, Remote Automated Weather System; UTM, Universal Transverse Mercator; °C, degrees Celsius; —, not available]

Station name	Map number	Data source	Station code	Station location			Daily precipitation records				
				UTM 11 (NAD83) Easting (m)	UTM 11 (NAD83) Northing (m)	Station elevation (m)	Start year	End year	Years of record	Average (mm)	Maximum (mm)
PRADO DAM	121	NCDC	47123	440,249	3,750,182	171	1948	1951	3.1	203.3	49
RADIUM HOT SPRINGS	122	NCDC	47220	356,253	3,829,802	634	1949	1954	5.9	441.8	81.5
REDLANDS	123	NCDC	47306	482,440	3,768,028	402	1927	2010	82	338.9	122.9
RIVERSIDE FIRE STN 3	124	NCDC	47470	464,058	3,756,804	256	1927	2009	80.8	256.5	112.3
RIVERSIDE CITRUS EXP	125	NCDC	47473	466,531	3,758,547	301	1948	2009	56.6	249.4	80.3
SAN ANTONIO CN MOUTH	126	NCDC	47711	438,470	3,780,842	729	1948	1967	19.1	572.5	217.2
SAN BERNARDINO F S 226	127	NCDC	47723	476,509	3,777,089	348	1927	2004	75.2	411.9	128.3
SAN DIMAS FIRE FC 95	128	NCDC	47749	425,955	3,774,123	292	1949	2010	57.6	464	195.6
SAN DIMAS TANBARK FLAT	129	NCDC	47750	429,280	3,784,599	854	1948	1951	3.2	383	116.1
SAN FERNANDO	130	NCDC	47759	364,915	3,794,543	296	1927	1974	45.8	415.1	191.8
SAN FERNANDO PH 3	131	NCDC	47762	362,561	3,797,905	381	1948	1951	3.1	292.1	54.9
SAN GABRIEL CANYON PH	132	NCDC	47776	416,236	3,779,749	227	1948	2010	61.8	578.5	206.5
SAN GABRIEL DAM FC425B-	133	NCDC	47779	420,615	3,785,256	451	1948	2010	56.1	733.7	313.9
SAN GABRIEL FIRE DEPT	134	NCDC	47785	398,458	3,774,468	137	1939	2010	69.2	434.1	176
SAN JUAN CANYON	135	NCDC	47836	448,618	3,710,396	114	2001	2009	7.7	295.8	66.3
SAN JUAN GRD STN	136	NCDC	47837	452,365	3,717,062	223	1948	1951	2.5	255.1	33
SAN PEDRO	137	NCDC	47876	382,549	3,731,468	3	1927	1964	36.5	275.1	130.8
SANTA ANA FIRE STN	138	NCDC	47888	419,640	3,734,134	41	1948	2010	61.8	330.3	107.2
SANTA ANITA F L FC 432	139	NCDC	47897	406,264	3,786,652	622	1949	1972	23.6	707.3	231.6
SANTA CATALINA WB AP	140	NCDC	47910	368,168	3,696,533	482	1948	1968	10.1	301.6	74.9
SANTA FE DAM	141	NCDC	47926	410,512	3,775,056	135	1948	1960	11.9	356.5	121.4
SANTA MONICA	142	NCDC	47950	362,957	3,765,002	18	1948	1979	24	337	136.6
SANTA MONICA PIER	143	NCDC	47953	361,503	3,764,069	4	1948	2010	56.4	319.9	129.8
SANTA PAULA	144	NCDC	47957	303,633	3,798,802	72	1948	2008	57.7	454.2	275.6
SANTIAGO DAM	145	NCDC	47987	433,104	3,738,765	261	1948	1965	16.8	319.7	118.9
SAUGUS PWR PLT 1	146	NCDC	48014	366,507	3,828,472	642	1948	2010	61	444.8	147.3
SEPULVEDA DAM	147	NCDC	48092	364,092	3,781,556	207	1948	1960	12	271.3	93
SHELL ABSORPTION PLT	148	NCDC	48158	416,754	3,756,979	207	1948	1966	17.6	357.1	130.8
SIERRA MADRE HENSZEY	149	NCDC	48210	403,140	3,781,139	345	1948	1958	9.8	543.6	171.2
SIGNAL HILL FC 415	150	NCDC	48230	391,767	3,740,231	31	1948	1972	24.3	262.3	116.3



**Table 2.** Climate stations and records used for estimating daily precipitation and maximum and minimum air temperature, Los Angeles Basin watershed model (LABWM), California.—Continued

[m, meter; mm, millimeter; NAD83, North American Datum of 1983; NCDC, National Climate Data Center; RAWS, Remote Automated Weather System; UTM, Universal Transverse Mercator; °C, degrees Celsius; —, not available]

Station name	Map number	Data source	Station code	Station location		Station elevation (m)	Daily precipitation records				
				UTM 11 (NAD83) Easting (m)	UTM 11 (NAD83) Northing (m)		Start year	End year	Years of record	Average (mm)	Maximum (mm)
SILVERADO RS	151	NCDC	48243	438,785	3,733,804	334	1948	1951	3.1	266.7	47
SLEEPY HOLLOW COLBY RC	152	NCDC	48290	397,154	3,795,986	1,068	1949	1954	5.9	530.7	170.4
SOMIS 3 NE	153	NCDC	48348	318,886	3,795,321	149	1956	1964	8	350.7	135.9
SOMIS 3 NW	154	NCDC	48349	311,217	3,795,473	153	1956	1977	20.2	408.5	136.9
SPADRA LANTERMAN HOSP	155	NCDC	48436	425,179	3,767,099	206	1955	1972	17.8	363.7	142.8
SUNLAND	156	NCDC	48660	380,237	3,792,494	445	1949	1966	16.6	406.8	134.6
SUNLAND TUJUNGA	157	NCDC	48662	381,751	3,790,622	534	1948	1949	1.3	242.5	49.8
SUSANA KNOLLS	158	NCDC	48700	346,474	3,792,986	332	1956	1977	21.2	402.5	149.9
THOUSAND OAKS 1 SW	159	NCDC	48904	324,945	3,783,956	239	2004	2008	3.6	267.7	51.3
THOUSAND OAKS	160	NCDC	48905	327,956	3,787,761	247	1956	1977	20.7	389	138.7
TOPANGA PATROL FC-6	161	NCDC	48967	352,399	3,772,648	227	1949	2010	56.7	628.8	242.3
TORRANCE AP	162	NCDC	48973	375,777	3,740,981	34	1949	2010	60.1	349.7	165.9
TRABUCO CANYON	163	NCDC	48992	445,271	3,724,429	296	1948	1951	3.2	295.7	46
TUJUNGA	164	NCDC	49047	381,774	3,792,474	555	1966	1987	20	543.5	192.3
TUJUNGA MILL FC 470	165	NCDC	49049	400,326	3,805,189	1,416	1948	1949	1.2	236.3	23.1
TUJUNGA SUMMIT FC 1029	166	NCDC	49050	400,326	3,805,189	1,509	1949	1951	0.8	186.5	32.8
TUSTIN IRVINE RCH	167	NCDC	49087	430,054	3,729,428	72	1927	2003	74.5	333.8	131.3
UNION OIL STEARNS ABS	168	NCDC	49138	419,816	3,755,101	217	1948	1970	19.6	365.3	110
U C LA	169	NCDC	49152	366,780	3,770,826	131	1948	2010	61.8	437.6	146.1
UPLAND	170	NCDC	49157	436,915	3,777,149	561	1948	1959	11.2	463.8	127.3
UPLAND 3 N	171	NCDC	49158	439,986	3,777,129	491	1959	1980	20.6	523.5	162.1
VALYERMO FIRE STN 79	172	NCDC	49250	420,303	3,812,394	1,098	1972	1985	12.3	275.6	79.3
VALYERMO RS	173	NCDC	49251	421,837	3,812,381	1,129	1948	1971	22.9	223	172.2
VAN NUYS FC15A	174	NCDC	49260	366,294	3,783,432	212	1949	1995	45.5	404.9	147.6
VICTORVILLE PUMP PT	175	NCDC	49325	471,858	3,821,521	871	1948	2009	60	138.1	76.2
VINCENT FS FC 120	176	NCDC	49345	395,069	3,816,836	956	1949	2000	50	212.2	83.1
WALNUT NI FC102C	177	NCDC	49431	419,963	3,762,684	149	1949	2000	50.8	411.7	142.5
WHITTIER CY YD FC106C	178	NCDC	49660	405,491	3,759,979	128	1949	2010	57.9	366.1	154.9
WOODLAND HLS PIERCE CL	179	NCDC	49785	354,827	3,783,447	241	2006	2010	4.3	337	72.9
WRIGHTWOOD	180	NCDC	49822	441,196	3,802,447	1,829	1997	2010	12.7	582.9	174

**Table 2.** Climate stations and records used for estimating daily precipitation and maximum and minimum air temperature, Los Angeles Basin watershed model (LABWM), California.—Continued

[m, meter; mm, millimeter; NAD83, North American Datum of 1983; NCDC, National Climate Data Center; RAWS, Remote Automated Weather System; UTM, Universal Transverse Mercator; °C, degrees Celsius; —, not available]

Station name	Map number	Data source	Station code	Station location		Station elevation (m)	Daily precipitation records				
				UTM 11 (NAD83) Easting (m)	UTM 11 (NAD83) Northing (m)		Start year	End year	Years of record	Average (mm)	Maximum (mm)
YORBA LINDA	181	NCDC	49847	424,196	3,750,264	107	1948	2007	38.8	347.8	132.1
ACTON	182	RAWS	50001	389,755	3,811,689	793	1995	2011	15.2	241.3	116.6
BELL CANYON	183	RAWS	50010	445,377	3,711,124	213	1993	2011	18	350	102.9
BEVERLY HILLS	184	RAWS	50011	370,217	3,776,541	384	1997	2011	11.7	510.7	427.5
BIG PINES	185	RAWS	50013	436,698	3,803,840	2,108	2002	2011	9.1	538.8	207
BURRO CANYON BAER	186	RAWS	50016	422,999	3,789,158	647	2003	2006	2.4	1085.2	194.1
CAMP 9	187	RAWS	50019	369,443	3,802,654	1,219	1995	2011	15.9	561.4	146.6
CHEESEBORO	188	RAWS	50024	341,773	3,783,909	503	1995	2011	16	352.3	127.3
CHILAO	189	RAWS	50025	404,947	3,799,599	1,661	1986	2011	23.8	353	162.6
CLAREMONT	190	RAWS	50027	435,074	3,777,404	501	1998	2011	13.1	520.8	111.3
CLEAR CREEK	191	RAWS	50029	393,996	3,792,619	914	2002	2011	9.1	796.5	194.1
CORONA	192	RAWS	50035	449,795	3,748,022	195	2001	2011	9.7	262.9	64.3
DEL VALLE	193	RAWS	50039	345,962	3,810,592	390	1998	2009	10.6	357.8	142.2
DEVORE	194	RAWS	50043	462,987	3,786,548	634	1990	2009	16.4	658	187.7
FREMONT CANYON	195	RAWS	50048	434,591	3,740,741	543	1991	2009	17.8	318.4	271
LEO CARRILLO	196	RAWS	50062	321,395	3,768,354	15	1999	2009	10	291.2	76.7
LITTLE TUJUNGA	197	RAWS	50063	375,152	3,795,089	424	2002	2009	6.9	453.7	115.6
LYTLE CREEK	198	RAWS	50066	456,271	3,788,167	851	2002	2009	7.5	966.5	261.9
MALIBU HILLS	199	RAWS	50067	349,255	3,769,458	480	2000	2009	9.4	559.2	210.1
PIRU	200	RAWS	50081	334,001	3,808,283	187	2001	2009	8	422.5	137.2
SANTA FE DAM	201	RAWS	50090	413,237	3,775,769	152	1993	2009	13.6	449.5	107.4







**Table 2.** Climate stations and records used for estimating daily precipitation and maximum and minimum air temperature, Los Angeles Basin watershed model (LABWM), California.—Continued

[m, meter; mm, millimeter; NAD83, North American Datum of 1983; NCDC, National Climate Data Center; RAWS, Remote Automated Weather System; UTM, Universal Transverse Mercator; °C, degrees Celsius; —, not available]

Station name	Daily maximum air temperature records						Daily minimum air temperature records					
	Start year	End year	Years of record	Average (°C)	Maximum (°C)	Minimum (°C)	Start year	End year	Years of record	Average (°C)	Maximum (°C)	Minimum (°C)
GLENDALE STAPENHORST F	—	—	—	—	—	—	—	—	—	—	—	—
GLENDORA FC 287B	—	—	—	—	—	—	—	—	—	—	—	—
HAINES CAN LWR FC 364	—	—	—	—	—	—	—	—	—	—	—	—
HAINES CNYN UPR FC367	—	—	—	—	—	—	—	—	—	—	—	—
HANSEN DAM	—	—	—	—	—	—	—	—	—	—	—	—
HESPERIA	—	—	—	—	—	—	—	—	—	—	—	—
HOEGEES FC 60 A	—	—	—	—	—	—	—	—	—	—	—	—
IRVINE RCH	2003	2010	6.7	26	45	10	2003	2010	6.7	11.4	23.3	-1.1
LA BREA CANYON HUNT	—	—	—	—	—	—	—	—	—	—	—	—
LA CRESCENTA FC251 C	—	—	—	—	—	—	—	—	—	—	—	—
LAGUNA BEACH	1928	2008	76.1	21.8	42.2	8.3	1928	2008	74.5	10.7	26.7	-6.1
LAGUNA BEACH #2	—	—	—	—	—	—	—	—	—	—	—	—
LA VERNE HTS FC 560 B	—	—	—	—	—	—	—	—	—	—	—	—
LECHUZA PTRL ST FC352B	—	—	—	—	—	—	—	—	—	—	—	—
LITTLE TUJUNGA GLD CR	—	—	—	—	—	—	—	—	—	—	—	—
LIVE OAK CANYON FC 230	—	—	—	—	—	—	—	—	—	—	—	—
LLANO SHAWNEE HILLS RC	1948	1965	16.8	23.3	41.7	-3.3	1948	1965	16.9	9	26.7	-12.2
LONG BEACH AQUARIUM	1970	1973	3	23.5	38.9	10.6	1970	1973	3	11.8	21.7	-0.6
LONG BEACH PUB SVC	1927	1969	41.1	22.4	43.9	8.3	1927	1969	41	12.2	26.1	-3.9
LONG BCH DAUGHERTY AP	1958	2010	52.7	23.5	43.9	8.3	1958	2010	52.7	12.7	25.6	-3.9
LOS ANGELES 6TH MAIN	—	—	—	—	—	—	—	—	—	—	—	—
LOS ANGELES TERMINAL A	—	—	—	—	—	—	—	—	—	—	—	—
LOS ANGELES INTL AP	1944	2010	65.8	21.2	43.3	7.8	1944	2010	66.2	13	25.6	-2.8
LOS ANGELES DWTN USC	1948	2010	62.2	23.9	45	7.8	1948	2010	62.2	13.7	28.3	-2.2
LYTLE CK FTHILL BLVD	—	—	—	—	—	—	—	—	—	—	—	—
LYTLE CREEK PH	—	—	—	—	—	—	—	—	—	—	—	—
LYTLE CREEK RS	—	—	—	—	—	—	—	—	—	—	—	—
MAGIC MTN	—	—	—	—	—	—	—	—	—	—	—	—
MARCH FLD	—	—	—	—	—	—	—	—	—	—	—	—
MONROVIA	1952	1953	1.1	25.6	40	13.3	1952	1953	1.1	8.6	19.4	0

**Table 2.** Climate stations and records used for estimating daily precipitation and maximum and minimum air temperature, Los Angeles Basin watershed model (LABWM), California.—Continued

[m, meter; mm, millimeter; NAD83, North American Datum of 1983; NCDC, National Climate Data Center; RAWS, Remote Automated Weather System; UTM, Universal Transverse Mercator; °C, degrees Celsius; —, not available]

Station name	Daily maximum air temperature records						Daily minimum air temperature records					
	Start year	End year	Years of record	Average (°C)	Maximum (°C)	Minimum (°C)	Start year	End year	Years of record	Average (°C)	Maximum (°C)	Minimum (°C)
MONTEBELLO	1979	2010	26	26.4	45	10	1979	2010	25.6	13.1	29.4	-1.7
MOORPARK	—	—	—	—	—	—	—	—	—	—	—	—
MT BALDY FC 85 G	—	—	—	—	—	—	—	—	—	—	—	—
MT BALDY NOTCH	1961	1972	8.1	13.1	35	-14.4	1961	1972	8.1	2.2	17.8	-21.1
MT WILSON CBS	1948	2010	60.4	18.6	38.9	-7.2	1948	2010	60.2	8.6	27.8	-12.8
NEWBURY PARK 4 SW	—	—	—	—	—	—	—	—	—	—	—	—
NEWHALL AP	1948	1949	1.2	25.1	41.7	1.7	1948	1949	1.2	5	16.7	-10.6
NEWHALL 5NW	1997	2010	13.3	24.2	46.7	4.4	1997	2010	13.3	11.4	29.4	-3.3
NEWHALL S FC32CE	—	—	—	—	—	—	—	—	—	—	—	—
NEWHALL US RS	—	—	—	—	—	—	—	—	—	—	—	—
NEWHALL	1989	1997	7.6	24.8	44.4	5	1989	1997	7.6	9.6	25.6	-5
NEWPORT BEACH HARBOR	1934	2010	73.8	19.9	41.7	8.9	1934	2010	73.8	12.7	25.6	-2.2
NORTH HOLLYWOOD	1948	1962	12.9	24.7	43.3	4.4	1948	1962	12.9	9.7	24.4	-6.7
NORTH RIDGE CAL STATE	1998	2010	11.6	25.4	45	8.3	1998	2010	11.7	12.2	26.1	-2.8
OLINDA	—	—	—	—	—	—	—	—	—	—	—	—
OPIDS CAMP FC 57 BE	1948	1958	7	20.4	41.1	-4.4	1948	1958	7.2	8.7	27.2	-12.2
ORANGE CO RSVR	—	—	—	—	—	—	—	—	—	—	—	—
OXNARD	1948	2002	53.3	21.2	39.4	7.2	1948	2002	53.3	10.6	23.3	-2.2
OXNARD WSFO	1998	2010	11.1	21.4	37.8	9.4	1998	2010	11.1	10.9	21.7	-0.6
PACIFIC COLOGE FC 356B	—	—	—	—	—	—	—	—	—	—	—	—
PACOIMA DAM FC 33 A-E	—	—	—	—	—	—	—	—	—	—	—	—
PALMDALE	1931	2010	78.2	25.2	45	-2.8	1931	2010	78	8.5	33.3	-14.4
PALMDALE FAA AP	1948	1974	25.7	24.8	44.4	-2.2	1948	1974	25.7	6.9	26.1	-16.1
PALOS VERDES ES FC43D	—	—	—	—	—	—	—	—	—	—	—	—
PASADENA	1927	2010	82.5	25.2	43.9	5	1927	2010	82.4	11	28.9	-8.3
PEARLBLOSSOM	1985	2010	23.5	24.4	42.8	-0.6	1985	2010	23.3	9.7	31.1	-13.3
PERRIS	1961	1973	11.2	25.8	45.6	5.6	1961	1973	11.2	7.3	23.3	-11.1
PERRIS 1 WSW	1951	1957	5.5	25.9	45.6	3.9	1951	1957	5.6	7.2	22.2	-5.6
PIRU 2 ESE	—	—	—	—	—	—	—	—	—	—	—	—
POMONA FAIRPLEX	1927	2010	75.6	25.2	45	2.2	1927	2010	75.5	8.9	30.6	-6.1



**Table 2.** Climate stations and records used for estimating daily precipitation and maximum and minimum air temperature, Los Angeles Basin watershed model (LABWM), California.—Continued

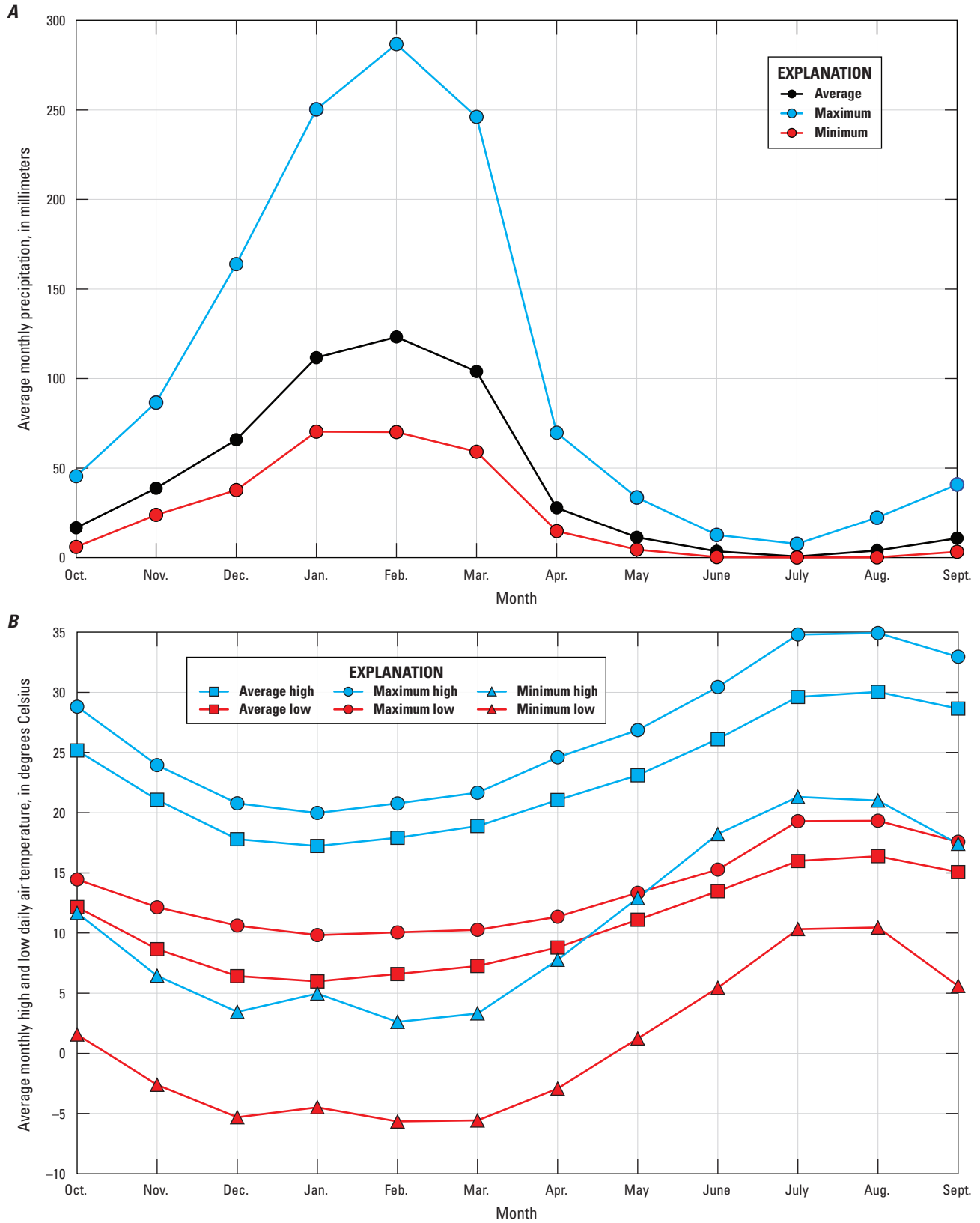
[m, meter; mm, millimeter; NAD83, North American Datum of 1983; NCDC, National Climate Data Center; RAWS, Remote Automated Weather System; UTM, Universal Transverse Mercator; °C, degrees Celsius; —, not available]

Station name	Daily maximum air temperature records						Daily minimum air temperature records					
	Start year	End year	Years of record	Average (°C)	Maximum (°C)	Minimum (°C)	Start year	End year	Years of record	Average (°C)	Maximum (°C)	Minimum (°C)
SILVERADO RS	—	—	—	—	—	—	—	—	—	—	—	—
SLEEPY HOLLOW COLBY RC	—	—	—	—	—	—	—	—	—	—	—	—
SOMIS 3 NE	—	—	—	—	—	—	—	—	—	—	—	—
SOMIS 3 NW	—	—	—	—	—	—	—	—	—	—	—	—
SPADRA LANTERMAN HOSP	—	—	—	—	—	—	—	—	—	—	—	—
SUNLAND	1949	1966	16.6	25.8	46.7	5	1949	1966	16.6	9.6	26.7	-5.6
SUNLAND TUJUNGA	1948	1949	1.3	25.6	45.6	3.9	1948	1949	1.3	9.5	23.3	-5.6
SUSANA KNOLLS	—	—	—	—	—	—	—	—	—	—	—	—
THOUSAND OAKS 1 SW	2004	2008	3.5	23.5	41.1	7.8	2004	2008	3.5	10.5	23.9	-3.9
THOUSAND OAKS	—	—	—	—	—	—	—	—	—	—	—	—
TOPANGA PATROL FC-6	—	—	—	—	—	—	—	—	—	—	—	—
TORRANCE AP	1949	2010	59.8	22.3	43.9	8.9	1949	2010	59.6	11.5	26.1	-6.1
TRABUCO CANYON	—	—	—	—	—	—	—	—	—	—	—	—
TUJUNGA	1966	1987	19.9	24.4	44.4	4.4	1966	1987	19.8	10	26.1	-3.9
TUJUNGA MILL FC 470	—	—	—	—	—	—	—	—	—	—	—	—
TUJUNGA SUMMIT FC 1029	—	—	—	—	—	—	—	—	—	—	—	—
TUSTIN IRVINE RCH	1927	2003	74.3	24.2	43.9	6.1	1927	2003	73.5	9.8	26.7	-7.8
UNION OIL STEARNS ABS	—	—	—	—	—	—	—	—	—	—	—	—
UCLA	1948	2010	61.7	21.8	42.2	7.8	1948	2010	61.7	13	30.6	-1.1
UPLAND	1948	1959	11	24.2	43.9	2.8	1948	1959	11.2	9.5	26.1	-5
UPLAND 3 N	1959	1980	20.6	24.7	43.9	5.6	1959	1980	20.6	8.9	25	-5
VALYERMO FIRE STN 79	1972	1985	11.6	22.9	43.3	-2.8	1972	1985	11.4	4.3	22.2	-14.4
VALYERMO RS	1948	1971	20.6	23.8	42.2	-3.9	1948	1971	20.8	4.5	29.4	-16.7
VAN NUYS FC15A	—	—	—	—	—	—	—	—	—	—	—	—
VICTORVILLE PUMPT	1948	2009	59.6	25.3	46.7	0	1948	2009	59.6	6.9	25.6	-18.3
VINCENT FS FC 120	—	—	—	—	—	—	—	—	—	—	—	—
WALNUT NI FC102C	—	—	—	—	—	—	—	—	—	—	—	—
WHITTIER CY YD FC106C	—	—	—	—	—	—	—	—	—	—	—	—
WOODLAND HLS PIERCE CL	2006	2010	4.3	27.1	44.4	10	2006	2010	4.3	8.9	23.3	-6.7
WRIGHTWOOD	1997	2010	12.6	17.2	35.6	-6.7	1997	2010	12.6	2.1	27.8	-15.6

**Table 2.** Climate stations and records used for estimating daily precipitation and maximum and minimum air temperature, Los Angeles Basin watershed model (LABWM), California.—Continued

[m, meter; mm, millimeter; NAD83, North American Datum of 1983; NCDC, National Climate Data Center; RAWS, Remote Automated Weather System; UTM, Universal Transverse Mercator; °C, degrees Celsius; —, not available]

Station name	Daily maximum air temperature records						Daily minimum air temperature records					
	Start year	End year	Years of record	Average (°C)	Maximum (°C)	Minimum (°C)	Start year	End year	Years of record	Average (°C)	Maximum (°C)	Minimum (°C)
YORBA LINDA	1948	2007	38.2	25.4	45.6	7.8	1948	2007	37.3	10.1	29.4	-5.6
ACTON	1995	2011	16.9	25	44.4	2.2	1995	2011	16.9	7.6	31.7	-8.3
BELL CANYON	1993	2011	18	24.2	43.9	2.2	1993	2011	18	12.1	31.1	0.6
BEVERLY HILLS	1997	2011	11.7	26	46.1	7.8	1997	2011	11.6	12.1	33.3	0.6
BIG PINES	2002	2011	9.1	18	35.6	-5	2002	2011	9.1	5.2	28.3	-15.6
BURRO CANYON BAER	2003	2006	2.3	22.1	38.3	6.7	2003	2006	2.3	9.6	21.1	-1.7
CAMP 9	1995	2011	15.9	20.3	42.8	-1.1	1995	2011	15.9	10.9	28.9	-17.8
CHEESEBORO	1995	2011	16	24.7	44.4	6.1	1995	2011	16	12.6	31.1	0
CHILAO	1986	2011	23.5	19	38.9	-3.7	1986	2011	23.5	9.5	28.1	-14.7
CLAREMONT	1998	2011	13.1	24.5	43.9	6.1	1998	2011	13.1	10.3	31.7	-2.8
CLEAR CREEK	2002	2011	9.1	21.3	39.4	1.1	2002	2011	9.1	12	28.9	-3.3
CORONA	2001	2011	9.7	26.5	46.1	9.4	2001	2011	9.6	11.9	27.2	-1.7
DEL VALLE	1998	2009	10.6	26	46.1	6.7	1998	2009	10.6	10.6	26.7	-4.4
DEVORE	1990	2009	17.6	24.8	46.1	3.3	1990	2009	17.5	12	31.1	-3.3
FREMONT CANYON	1991	2009	17.7	23.8	45	6.7	1991	2009	17.7	13	31.7	1.1
LEO CARRILLO	1999	2009	10	21.6	37.8	11.1	1999	2009	10	12.1	26.1	1.7
LITTLE TUJUNGA	2002	2009	6.9	24.7	47.8	4.4	2002	2009	6.8	10.6	26.1	-2.2
LYTLE CREEK	2002	2009	7.5	25	44.4	3.9	2002	2009	7.5	9.7	27.2	-5
MALIBU HILLS	1995	2009	13.9	23.6	46.1	7.2	1995	2009	13.9	12.9	30	-5.6
PIRU	2001	2009	8	23.9	41.1	5	2001	2009	7.9	10.4	25	-2.2
SANTA FE DAM	1993	2009	13.6	27	46.1	9.4	1993	2009	13.6	12.1	28.3	-2.8



**Figure 3.** Average monthly values estimated for water years 1915–2014 for the Los Angeles Basin watershed model (LABWM) area, California, for *A*, precipitation; and *B*, maximum and minimum daily air temperature.



Average monthly maximum and minimum air temperatures in the LABWM area were estimated for water years 1915–2014 by using the modified inverse-distance-squared interpolation, the PRISM 30-year (1971–2000) normal maximum and minimum average daily air temperature (Daly and others, 2004), and daily maximum and minimum air temperature records from a network of 90 climate stations covering the LABWM and having records of daily air temperature (table 2). The results indicate that June through October are generally the hottest months for most locations, with average maximum daily air temperature of more than 25 degrees Celsius for all months, and average minimum daily air temperature of more than 11 degrees Celsius for all months (fig. 3B). Similar to precipitation, average monthly air temperature showed considerable spatial variability in the LABWM area. For example, the average maximum-high temperature for August was 34.9 degrees Celsius, compared to the average minimum high of 20 degrees Celsius.

The notable spatial variability in precipitation and air temperature is based on topography and distance from the coastline. The average annual precipitation for the LABWM, estimated for water years 1915–2014 by using the modified inverse-distance-squared spatial-interpolation method, ranged from 901–1,161 millimeters per year (mm/yr) in the summit areas of the San Gabriel Mountains to 301–400 mm/yr for most of the coast and in the LAGSA (fig. 4). Compared to the interior valley, higher-elevation locations in the foothills bordering San Fernando and San Gabriel Valleys had higher precipitation, including areas with more than 501 mm/yr precipitation. In the Los Angeles recharge-study area, relatively high precipitation of 501 to 700 mm/yr fell in the Santa Monica Mountains, whereas precipitation was lower, 284 to 400 mm/yr, in most of the Los Angeles recharge-study area and the LAGSA. The estimated basin-wide average precipitation rate for water years 1915–2014 for the LABWM area was 488 mm/yr, compared to a basin-wide average precipitation rate of 336 mm/yr for the LAGSA.

Average air temperature in the LABWM area, estimated for water years 1915–2014 by using the modified inverse-distance-squared spatial-interpolation method, ranged from high values of about 18–19 degrees Celsius for many areas in the San Gabriel and San Fernando Valleys to low values of about 6–10 degrees Celsius for the highest elevations in the San Gabriel Mountains (fig. 5). In the Los Angeles recharge-study area, the warmer average daily air temperatures of about 18 to 19 degrees Celsius were measured in the higher elevations of the Santa Monica Mountains and throughout the northeastern part of the model area. Cooler average daily air temperatures of about 17 degrees Celsius were measured along the coast. The mean daily air temperature in the LABWM area was 16.8 degrees Celsius.

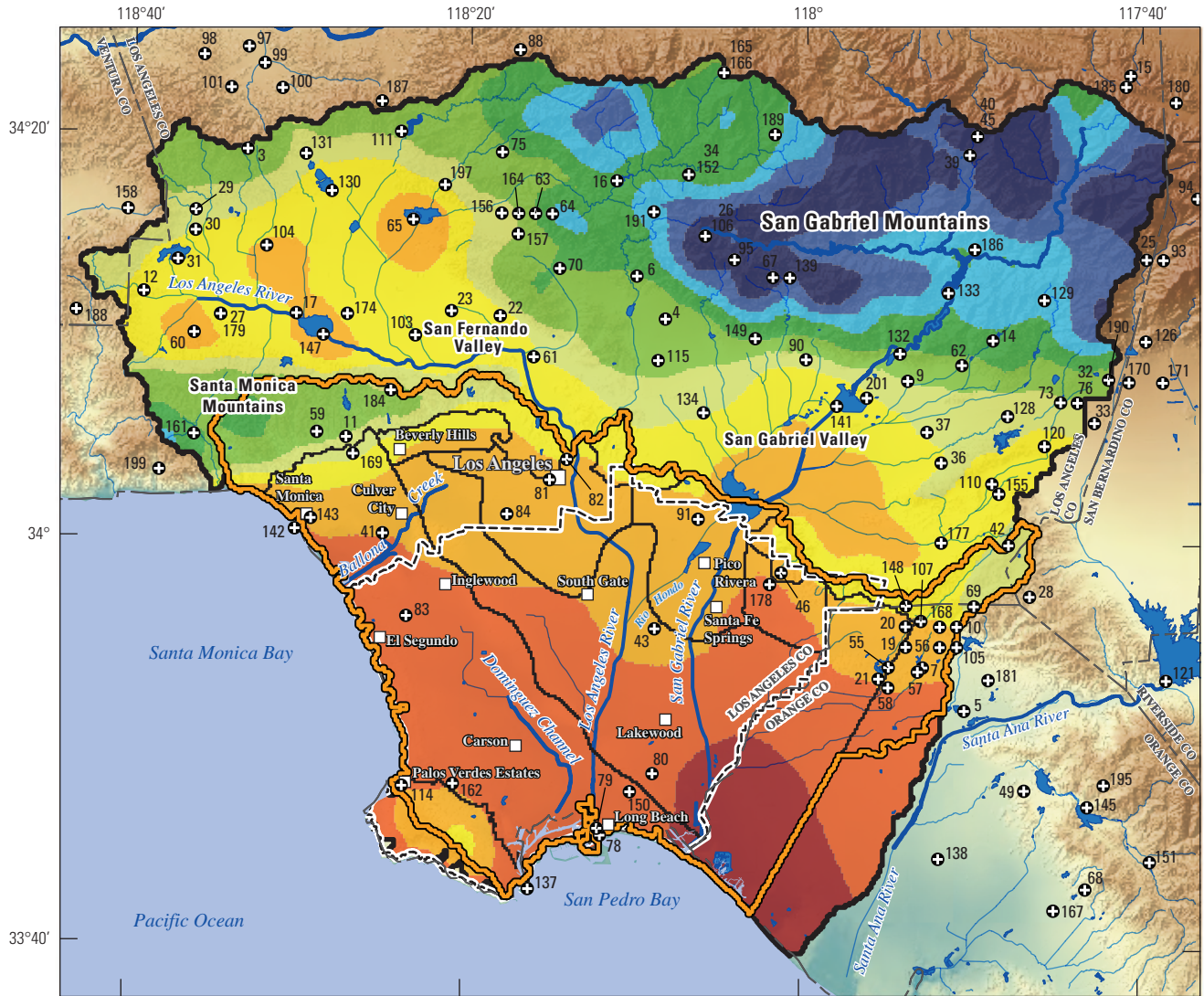
## Influence of Urban Irrigation

Urban irrigation can influence the groundwater hydrologic cycle by increasing the amount of water available to infiltration through on-site percolation (Grimmond and others, 1986) and can influence the surface-water hydrologic cycle by affecting runoff rates from rainfall (Sample and Heaney, 2006). The volume of urban irrigation applied to the landscape can be large, exceeding natural rainfall in certain areas such as the Los Angeles Basin (California Department of Water Resources, 1975). Among the urban land uses that irrigate, residential areas typically use the most water in an urban environment compared to commercial, industrial, and agricultural users (Grimmond and Oke, 1986; California Department of Water Resources, 1994; City of Los Angeles Department of Water and Power, 2001; San Diego County Water Authority, 2001). In addition, residential neighborhoods occupy the largest area of all the land-use classes in the Los Angeles Basin (Southern California Area Governments, 2005). Studies have shown that more than 50 percent of the water used in a typical household is used for irrigation (Grimmond and Oke, 1986; Mayer and others, 1999). For the residential areas in the city of Los Angeles, for example, this equates to approximately 225 million cubic meters (22,500 ha-m) of water used for irrigation each year, potentially influencing the urban hydrologic cycle (Johnson and Belitz, 2012). Ideally, most or all of the applied urban irrigation water would be used by plants and, thus, lost to evapotranspiration (ET). Over-watering, because it is difficult to estimate the exact water demand, is not uncommon, and a portion of the applied water can contribute to recharge and runoff in addition to ET. An increase in recharge and runoff can also increase in response to natural precipitation because of the wet antecedent soil conditions caused by urban irrigation.

## Model Description

The FORTRAN code INFILv3 simulates daily precipitation-runoff processes on a watershed scale by using a daily root-zone water balance that accounts for the infiltration of runoff, which can result in areas of locally high net infiltration and recharge where surface-water inflows are concentrated or frequent (U.S. Geological Survey, 2008). Application of INFILv3 allows for the estimation of spatially distributed water-budget components on a daily, monthly, and annual basis. The INFILv3 simulation results are used to gain a better understanding of mechanisms responsible for net infiltration, evapotranspiration, runoff, and recharge. Model results can be mapped and, subsequently, used to evaluate the integrated effect of spatially distributed climate, terrain, and watershed characteristics (for example, vegetation, soils, and geology) on the spatial and temporal distribution of water-budget components, including runoff and recharge.

24 Estimating Spatially and Temporally Varying Recharge and Runoff from Precipitation and Urban Irrigation



Base modified from U.S. Geological Survey and other State digital data, various scales  
 Universal Transverse Mercator, zone 11  
 North American Datum 1983



EXPLANATION

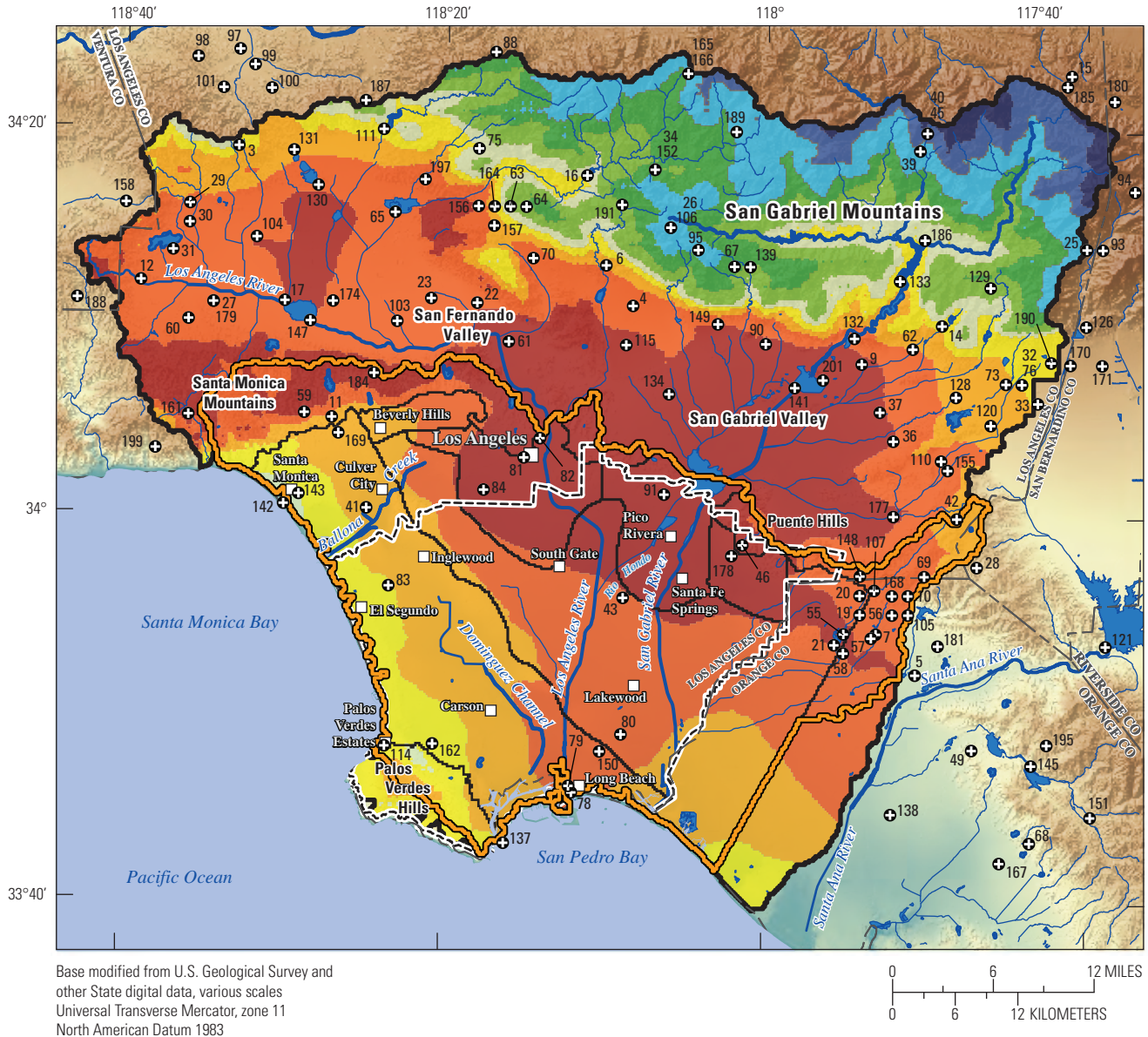
Los Angeles Basin watershed model interpolated 1915–2014 precipitation, in millimeters per year

<ul style="list-style-type: none"> <li><span style="display: inline-block; width: 15px; height: 10px; background-color: #800000; border: 1px solid black; margin-right: 5px;"></span> 284–300</li> <li><span style="display: inline-block; width: 15px; height: 10px; background-color: #FF4500; border: 1px solid black; margin-right: 5px;"></span> 301–350</li> <li><span style="display: inline-block; width: 15px; height: 10px; background-color: #FFA500; border: 1px solid black; margin-right: 5px;"></span> 351–400</li> <li><span style="display: inline-block; width: 15px; height: 10px; background-color: #FFD700; border: 1px solid black; margin-right: 5px;"></span> 401–450</li> <li><span style="display: inline-block; width: 15px; height: 10px; background-color: #90EE90; border: 1px solid black; margin-right: 5px;"></span> 451–500</li> </ul>	<ul style="list-style-type: none"> <li><span style="display: inline-block; width: 15px; height: 10px; background-color: #3CB371; border: 1px solid black; margin-right: 5px;"></span> 501–600</li> <li><span style="display: inline-block; width: 15px; height: 10px; background-color: #008000; border: 1px solid black; margin-right: 5px;"></span> 601–700</li> <li><span style="display: inline-block; width: 15px; height: 10px; background-color: #00BFFF; border: 1px solid black; margin-right: 5px;"></span> 701–800</li> <li><span style="display: inline-block; width: 15px; height: 10px; background-color: #4169E1; border: 1px solid black; margin-right: 5px;"></span> 801–900</li> <li><span style="display: inline-block; width: 15px; height: 10px; background-color: #191970; border: 1px solid black; margin-right: 5px;"></span> 901–1,161</li> </ul>
--	--

- Los Angeles Basin watershed model area boundary
- Water Replenishment District
- Los Angeles recharge study area
- Water bodies and flood-control areas
- Major rivers and streams
- Minor rivers and streams
- Los Angeles groundwater basins
- County line
- 167 Climate stations (map number from table 2)

Figure 4. Average annual precipitation estimated for water years 1915–2014 for the Los Angeles Basin watershed model (LABWM), California.





**EXPLANATION**

<b>Los Angeles Basin watershed model interpolated 1915–2014 average air temperature, in degrees Celsius</b>	Los Angeles Basin watershed model area boundary
5.92–10.00	Water Replenishment District
10.10–12.00	Los Angeles recharge study area
12.10–14.00	Water bodies and flood-control areas
14.10–15.00	Major rivers and streams
15.10–16.00	Minor rivers and streams
16.60–17.00	Los Angeles groundwater basins
17.10–17.50	County line
17.60–18.00	Climate stations (map number from table 2)
18.10–18.80	

**Figure 5.** Average air temperature estimated for water years 1915–2014 for the Los Angeles Basin watershed model (LABWM), California.

In contrast to empirical precipitation-scaling methods (Maxey and Eakin, 1949; Crippen, 1965; Reichard and others, 2003; Farrar and others, 2006), INFILv3 provides a deterministic, hydrologic process-based method for estimating spatially varying, transient runoff and recharge. Conceptually, the use of a watershed model could provide a better representation, compared to empirical methods, of variations in runoff and recharge caused by the spatially and temporally varying physical and climatic characteristics of the watersheds modeled. The INFILv3 code was intended to provide an estimate of the temporally and spatially varying natural-recharge component (recharge in response to rainfall, snowmelt, and runoff) of the total recharge to the LAGSA. Because of the large amount of urban irrigation in the LAGSA, in this study, the INFILv3 code was modified to include urban irrigation as an addition to the spatially distributed daily precipitation input to enable simulation of the urban return-flow component of anthropogenic recharge. As mentioned previously, this study did not account for induced recharge from retention basins, spreading grounds, and injection wells. These volumes of recharge are quantified by the WRD (Water Replenishment District of Southern California, 2013).

The INFILv3 code is a grid-based, distributed-parameter, deterministic water-balance application for simulating daily precipitation-runoff on the watershed scale. The INFILv3 code is similar to that of other precipitation-runoff models, such as the Basin Characterization Model (BCM; Flint and Flint, 2012), the Soil Water Balance Model (SWB; Westenbroek and others, 2010), and the Precipitation Runoff Modeling System (PRMS; Markstrom and others, 2008). Unlike the BCM, however, the INFILv3 code allows for the daily routing of surface-water and seepage flows from upstream to downstream grid cells, and unlike BCM, SWB, and PRMS, INFILv3 uses a multi-layer discretization to simulate the redistribution of water in the root zone in response to downward percolation and variable transpiration. The INFILv3 code calculates the temporal and spatial distribution of daily net infiltration of water across the lower boundary of the root zone. The bottom of the root zone is the estimated maximum depth below ground surface affected by ET. In many field applications, net infiltration can be assumed to equal recharge to an underlying water-table aquifer and can be used to define the recharge boundary condition for groundwater-flow models (Hevesi and others, 2003; Nishikawa and others, 2005; Rewis and others, 2006). A more detailed description of INFILv3 model is provided in Hevesi and others (2003), and documentation of the model is available at <http://water.usgs.gov/nrp/gwsoftware/Infil/Infil.html> (United States Geological Survey, 2008).

The INFILv3 code requires that the watershed being simulated is discretized into a horizontal grid-based network of square, equal-area model cells (fig. 6). The grid-based discretization was used to spatially distribute daily precipitation and daily maximum and minimum air-temperature estimates by using a modified

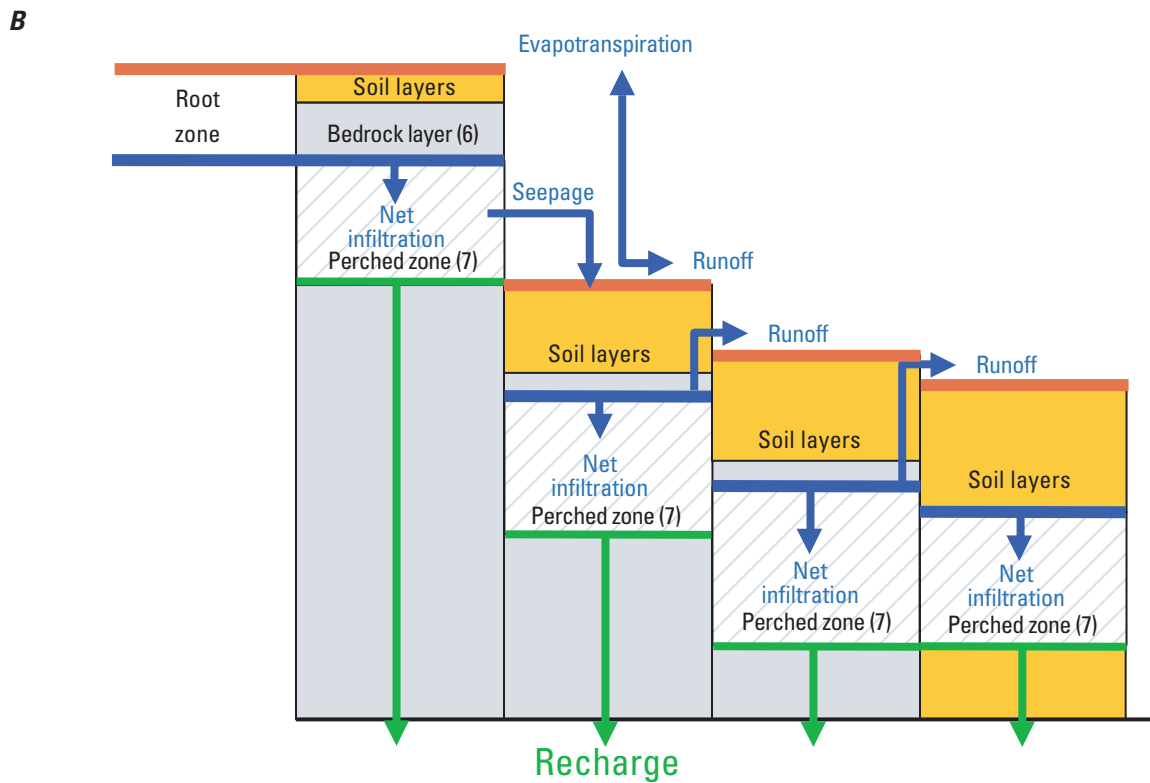
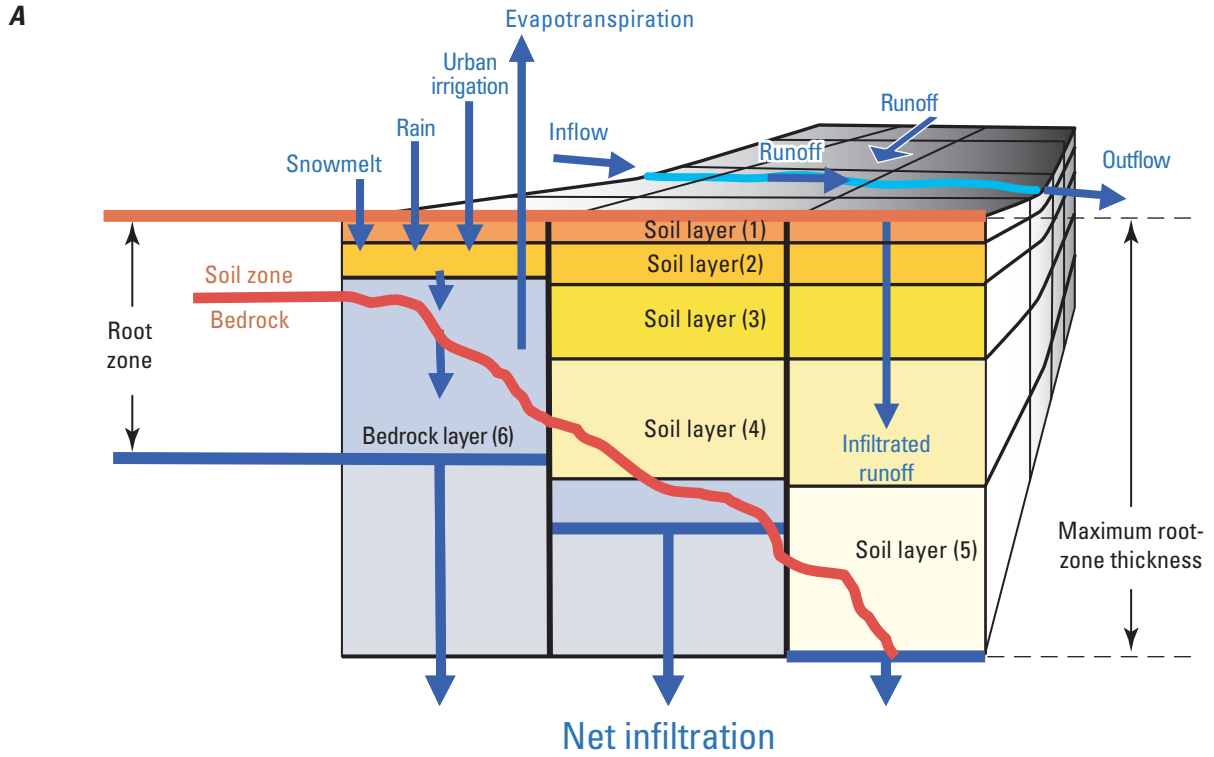
inverse-distance-squared interpolation, daily climate records from a network of climate stations, and estimates of average monthly precipitation and maximum and minimum air temperature (Hevesi and Christensen, 2015; Flint and Martin, 2012). The grid-based discretization is also used to distribute model parameters representing the physical characteristics of the watersheds in the model domain. Each grid cell is uniquely defined in terms of climate inputs and model parameters. The model cells are connected into a drainage network, and runoff generated by a cell is routed across the grid using a convergent-flow, cascade-routing process (Hevesi and others, 2003).

The INFILv3 code provides an estimate of recharge based on simulated daily net infiltration, where net infiltration is defined as the percolation of water from rain, snowmelt, and runoff below the maximum depth of the root zone or the zone of ET (Hevesi and others, 2003). Daily net infiltration and ET are simulated by INFILv3 by using a multi-layered representation of the root-zone, and simulated daily runoff is allowed to infiltrate into the root-zone during the process of surface-water flow routing, thereby accounting for the effects of streamflow on recharge (fig. 6A).

The INFILv3 code has been applied to studies of groundwater recharge in the southern California region, including studies of the Death Valley regional flow system (Hevesi and others, 2003), the Joshua Tree Basin (Nishikawa and others, 2005), and the San Gorgonio Pass area (Rewis and others, 2006). In these studies, simulated net infiltration was used as an estimate of recharge. The more recent applications of INFILv3 for the Big Bear Valley and San Gorgonio Pass study areas in southern California used a modified version of the code that incorporated an additional layer underneath the root zone, referred to as a shallow perched zone, to improve estimation of recharge by accounting for the effects of lateral groundwater flow and seepage (Flint and Martin, 2012; Hevesi and Christensen, 2015). The modified INFILv3 code version that includes a shallow perched zone was used in the LABWM.

## Root-Zone Water Balance

The INFILv3 code uses up to six layers to simulate the root-zone water balance, including net infiltration through the root zone. The modified INFILv3 code includes a seventh layer underlying the root zone, referred to as the shallow perched zone, to simulate lateral groundwater flow in the upper unsaturated zone (fig. 6B). The root zone is modeled by using a maximum of five upper layers to represent the soil component of the root zone and a lower sixth layer to represent the geologic unit (either bedrock or unconsolidated deposits) underlying the soil zone (fig. 6A). All root-zone layers can have uniform or variable thicknesses and are parameterized by using maps of geology (Jennings, 1997), soils (U.S. Department of Agriculture, 1994), and vegetation (California Department of Forestry and Fire Protection, 2002).



**Figure 6.** Grid, water storage components, and flow processes used by the INFILv3 code to simulate the spatial distribution of flows by the Los Angeles Basin watershed model (LABWM), California: *A*, the multi-layered root zone; *B*, the perched zone.

The bottom of the root zone is the estimated maximum depth below ground surface affected by ET.

The INFILv3 code does not directly account for interception storage and surface-retention storage; however, the model can indirectly account for these components by increasing the estimated soil thickness, which has the effect of increasing ET by increasing the storage capacity of the root zone. The water-balance calculations are based on water volumes, rather than water mass, because it is assumed that temperature effects on water density are negligible. The calculations use water-equivalent depths to represent volumes because all grid cells have equivalent areas.

The INFILv3 code uses a daily time step for simulating the water balance of the root zone and an hourly time step for simulating solar radiation and potential evapotranspiration (PET). The simulated daily water balance of the root zone includes precipitation (as either rain or snow), snow accumulation, sublimation, snowmelt, infiltration to the root zone, ET, percolation through the root zone, water-content changes for each root-zone layer, surface-water runoff, and net infiltration from the root zone (defined as drainage from the bottom root-zone layer; fig. 6A). Daily PET is simulated by using an hourly time step and an energy-balance model to improve representation of the shading effects of rugged terrain relative to changes in solar position during the year (Flint and Childs, 1987). Daily ET is simulated as a combined function of daily PET; the vertical distribution of available water in the root-zone layers; and the root-zone density, where the root-zone density represents the characteristics of vegetation.

### Shallow Perched-Zone Fluxes

The modified INFILv3 code includes a perched-groundwater zone (layer 7) beneath the bedrock layer (layer 6) to simulate lateral groundwater flow back to the root zone (seepage) and downward flux (recharge) beneath the root zone (Flint and Martin, 2012; fig. 6B). The perched-groundwater zone is used to simulate the seepage of shallow groundwater back into the active root zone, a process that was considered potentially significant in rugged mountainous areas with steep slopes (Rewis and others, 2006; Flint and Martin, 2012; Hevesi and Christensen, 2015). Seepage flow allows for a portion of simulated net infiltration to flow laterally to the active root zone of the downstream cell. In general, the net effect of seepage flow is to reduce recharge for the upstream model cell, while increasing ET and runoff for downstream cells. The additional inflow from seepage can also potentially increase recharge for downstream cells. Basin-wide effect of seepage flow, however, tends to be a reduction in recharge and a corresponding increase in ET.

The shallow perched zone (layer 7) is assigned an upper hydraulic conductivity that defines the rate at which water infiltrates the top of the perched zone and a lower hydraulic conductivity that defines the maximum rate at which water percolates vertically down through the perched zone to become recharge. The upper hydraulic conductivity also is used to define the maximum lateral-seepage rate from upstream cells to downstream cells. The lateral-seepage rate is a function of a calculated hydraulic gradient between the upstream and downstream cells, the relative water content of the upstream cell, and the upper hydraulic conductivity of the upstream cell. A multiplier is included to allow scaling of the upper hydraulic conductivity as a means of representing anisotropy or preferential lateral flow in the perched aquifer (this commonly is done to model preferential flow in watershed models). The hydraulic gradient is calculated by using the elevation difference and horizontal distance between adjacent upstream and downstream cell centroids. The relative water content is calculated as the ratio of water stored in a grid cell at each time step to an assumed perched-zone storage capacity. If the perched-zone storage capacity is exceeded for a given daily time step, the excess water is added back to the root zone; if the root zone is fully saturated, the excess water is added to the surface-water runoff.

### Urban Irrigation

In this study, the INFILv3 code was modified to include estimated urban irrigation as an inflow to the hydrologic system (fig. 6A). As stated previously, urban irrigation is a significant component of the LABWM water balance, potentially resulting in increased recharge and runoff in addition to increased ET. Average daily irrigation rates were estimated on a quarterly basis (January–March, April–June, July–September, and October–December) and incorporated in the model as a boundary condition consisting of a specified daily irrigation rate for each irrigated cell (uniform for each quarter, but varying from quarter to quarter). The location of irrigated cells was defined by using land-use maps. The daily irrigation rates were scaled for each cell by using the percentage of pervious area defined for each cell, as described in greater detail in this section.

Actual water-delivery records that could be used for estimating landscape irrigation in urban and suburban areas were difficult to obtain for most of the LABWM area; however, as part of previous research (Johnson, 2005; Johnson and Belitz, 2012), water records from 1996 to 1999 were acquired from nearly 1,795 single-family residential homes and townhomes in 65 randomized and spatially distributed neighborhoods in the San Fernando Valley. The neighborhoods



analyzed in the study consisted of 8 to 55 homes, with an average home count of 28. The average neighborhood size was 2.48 ha. These water-delivery records were used to estimate the amount of irrigation applied to single-family residential areas and, subsequently, to other land use classes.

The San Fernando Valley study area was initially chosen for a number of reasons: (1) the valley is administered by one city, which allows for consistency of water-delivery records; (2) land use in the valley is representative of other areas of the Southwestern U.S., offering a mixture of residential, commercial, and industrial land uses for constructing and calibrating methodologies; (3) the valley has a wide range of social-economic variables, including income, household size, lot size and water use, allowing a diversity of water-use patterns; and (4) the valley is surrounded by mountains, isolated from oceanic influences, and relatively flat, which help to minimize the climatic variability across the valley.

Water-delivery data were obtained from the Los Angeles County Department of Power and Water (LACDPW) for October 1996 through April 1999. The data were provided in 2-month billing cycles and were subsequently aggregated and normalized into a monthly water-delivery value for each neighborhood. Neighborhood water-meter readings that contained less than three homes were considered partial readings and not included in the averaging. The water-delivery data were normalized by dividing by the total area of each neighborhood. Figure 7 shows the aggregate water usage for the period sampled.

The minimum-month method was used to estimate irrigation by subtracting the minimum month of water use from all other months (Johnson, 2005). The minimum month is assumed to be composed mostly of indoor water use and represents the baseline water usage; therefore, subtracting the minimum month results in an estimation of irrigation. For the sampling period, the minimum month was March 1998, one of the wettest months during the study period, with a rate of 28.8544 mm (fig. 7). Irrigation, therefore, was computed as follows:

$$I_{nhood}(t) = WD_{nhood}(t) - 28.8544 \quad (1)$$

where

$I_{nhood}(t)$  is the irrigation rate (mm) for the average neighborhood per month, and

$WD_{nhood}(t)$  is the water-delivery rate (mm) for the average neighborhood per month.

By using equation 1, table 3 was constructed to aggregate irrigation on a quarterly basis. A warmer month with a higher ET rate requires greater amounts of irrigation to keep plants healthy. Averaging the 2 years can produce a general estimate of irrigation applied in the entire neighborhood (table 3).

The estimated irrigation was applied as an average quarterly rate for the entire 110-year simulation period. The average precipitation for the period analyzed (December 1996–February 1999) was representative of the long-term average precipitation.

In order to apply an irrigation rate to other land-use classes, the irrigation computed for the residential neighborhoods must be scaled up to a fully landscaped and irrigated parcel by multiplying it by the amount of irrigated landscaping in the neighborhood. This was necessary because the average neighborhood both consisted of an impervious portion (house, driveway, and so on) and a pervious portion (grass, landscaping, and so on). It was assumed that irrigation was applied only to the pervious areas.

$$I(t) = (I_{nhood}(t)) / (Firr_{nhood}) \quad (2)$$

where

$I(t)$  is the irrigation rate for a fully irrigated and landscaped parcel, computed quarterly;

$I_{nhood}(t)$  is the irrigation rate (mm) for the average neighborhood per month; and

$Firr_{nhood}$  is the fraction of irrigated landscaping in the average neighborhood.

An estimate of perviousness was based on a land-use map acquired from the Los Angeles County Department of Power and Water (2006). This map consisted of digitized polygons that grouped land-use classes together and identified the amount of imperviousness in each class. Milesi and others (2005) have shown that impervious surface area is inversely correlated to turfgrass in urban areas. The percentage of pervious area for each land-use class, therefore, was calculated by subtracting the reported imperviousness value from 100 percent. All 65 neighborhoods were in the “high-density single-family residential” class, which has a perviousness value of 58 percent (table 4). This value of  $Firr_{nhood}$  was used in equation 2 to calculate the quarterly irrigation rate for a parcel.

The distribution of urban irrigation was estimated by applying the irrigation rate to selected urban land-use classes and their reported percentage perviousness areas (table 4).

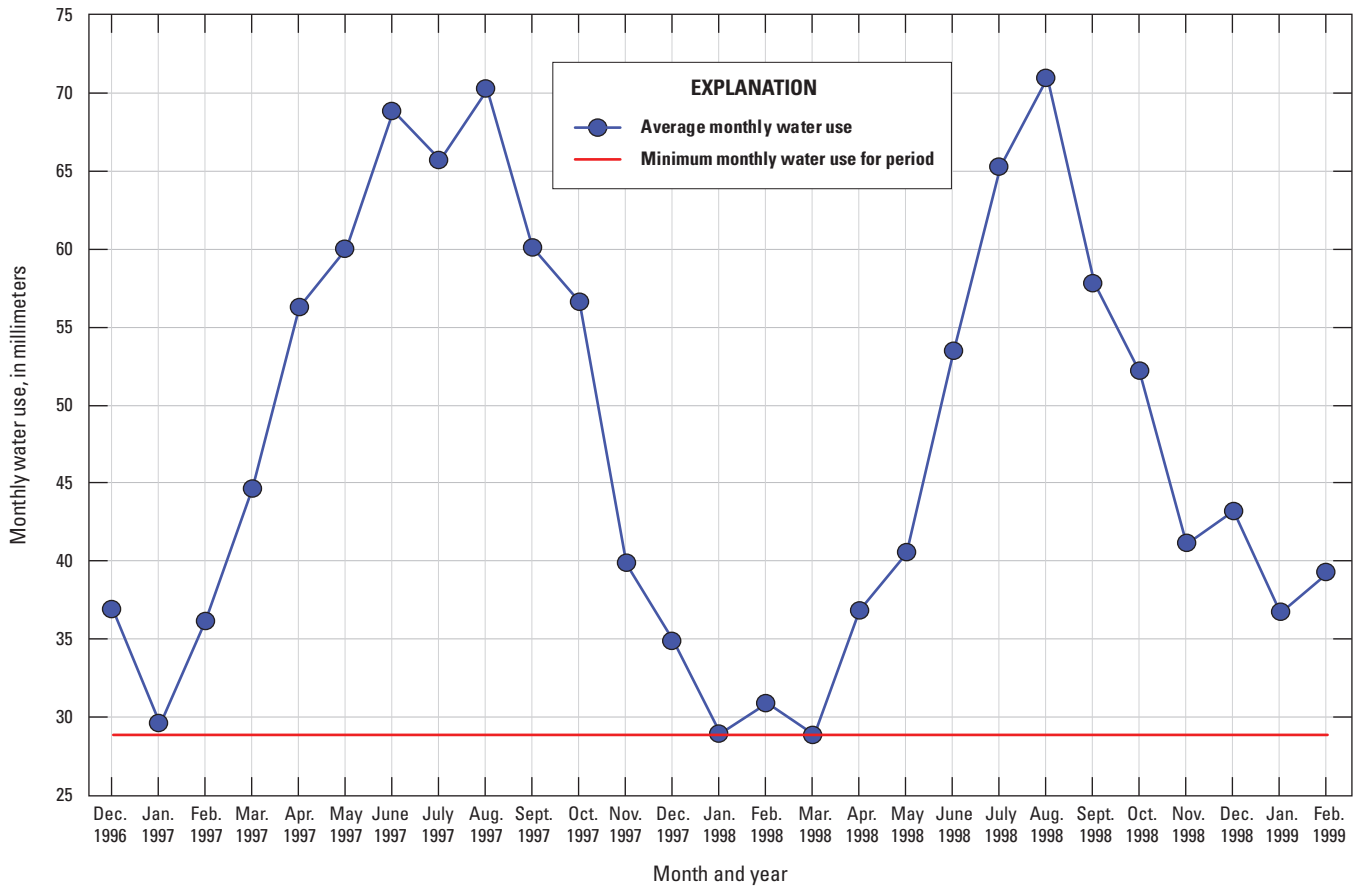
$$I_{lu}(t) = I(t) \times Firr_{lu} \quad (3)$$

where

$I_{lu}(t)$  is the irrigation rate (mm) for a particular land-use class, computed quarterly;

$I(t)$  is the irrigation rate for a fully irrigated and landscaped parcel, computed quarterly; and

$Firr_{lu}$  is the fraction of irrigated landscaping (perviousness) for a particular land-use class.



**Figure 7.** Average water delivery to 1,795 single-family residential homes in the San Fernando Valley, Los Angeles Basin watershed model (LABWM), California (1 millimeter is equal to 1 liter per square meter).

**Table 3.** Average irrigation rates, in millimeters, estimated for 1,795 high-density single-family residential homes by using the minimum-month method, Los Angeles Basin watershed model (LABWM), California.

[The last column shows the scaled-irrigation rate for a parcel that is fully landscaped and irrigated. The average neighborhood was 58 percent landscaped, based on Los Angeles County Department of Public Works (LACDPW), 2005.]

Quarter	1997	1998	Estimated average quarterly irrigation (millimeters)	Estimated average quarterly irrigation adjusted to 100 percent pervious land area (millimeters)
1	24	2	17	30
2	99	44	71	123
3	109	107	108	187
4	45	50	46	80
Year total	277	204	244	420



**Table 4.** Top 10 land-use classes (by area) of the San Fernando Valley, Los Angeles Basin watershed model (LABWM), California.

[Source: Southern California Area Governments, 2005. Abbreviations: LACDPW, Los Angeles County Department of Public Works; —, not applicable]

LACDPW land-use code	LACDPW land-use class	Area (hectares)	Percentage of total	Description	Contains irrigated landscaping	Percentage pervious <sup>1</sup>
1111	Residential	25,148	48.7	High-density single family residential	Yes	58
3100	Vacant	6,669	12.9	Vacant undifferentiated	No	—
1123	Residential	2,864	5.6	Low-rise apartments, condominiums, and townhouses	Yes	14
1311	Industrial	2,072	4	Manufacturing, assembly, and industrial services	No	—
1223/1224	Commercial	1,853	3.6	Modern/older strip development	Yes	3.5
1112	Residential	1,444	2.8	Low-density single family residential	Yes	79
1413	Transportation	1,088	2.1	Freeways and major roads	Yes	9
1437	Transportation	855	1.7	Improved flood waterways and structures	No	—
1810	Open space and recreation	743	1.4	Golf courses	Yes	97
1821	Open space and recreation	670	1.3	Developed local parks and recreation	Yes	90

<sup>1</sup> Percentage pervious from Los Angeles County Department of Public Works.

## Model Development

Development of the LABWM consisted of (1) defining the simulation period, including the model initiation and target-simulation periods; (2) defining the spatial (horizontal and vertical) discretization; (3) developing the spatially distributed model parameters representing the physical characteristics of the watershed; (4) developing the temporally and spatially distributed climate inputs; (5) specifying atmospheric parameters for simulating PET; (6) specifying model coefficients used in empirical functions and controls for input and output options; (7) defining boundary conditions; and (8) defining initial conditions. The simulation period used in the INFILv3 code is dependent on the availability of climate data for developing a continuous time series of spatially interpolated daily climate input. Model discretization primarily consisted of developing a gridded representation of the LABWM area, with the grid defining the INFILv3 hydrologic response units as equal-area, square cells. Development of model parameters and climate inputs included compiling and processing available Geographic Information System (GIS) data and daily climate records. Model coefficients included empirical parameters used to model snowmelt and sublimation, to define stream-channel characteristics, and to define precipitation intensity by using specified winter and summer storm durations. Boundary conditions were the daily surface-water inflows from model units upstream from the unit being modeled. Initial conditions were the starting water contents of the root-zone layers, the perched zone, and the snowpack.

## Simulation Period

The LABWM was developed for a 110 year simulation period that started January 1, 1905, and ended October 31, 2014. Continuous daily simulations for multi-year periods prior to January 1, 1905, were problematic because of a sparsity of continuous daily climate records. The simulation period included a 117 month (9.75 year) model-initialization period from January 1, 1905, through September 30, 1914, followed by a 100-year target-simulation period from October 1, 1914, through September 30, 2014 (water years 1915–2014). The initialization period is used to mitigate the effects of the initial conditions, which, in this study, were estimated on the basis of values used in previous INFILv3 applications (Hevesi and others, 2003; Rewis and others, 2006; Flint and Martin, 2012; Hevesi and Christensen, 2015). Initial conditions for precipitation-runoff models, including INFILv3, are generally not known and require at least some initialization period to help minimize uncertainties associated with the assumed or estimated initial conditions (Markstrom and others, 2008; Flint and Martin, 2012; Hevesi and Christensen, 2015).

## Spatial and Temporal Discretization

### Horizontal Discretization

Development of the LABWM required the discretization of the model area in a horizontal two-dimensional grid of equal-area (square) cells, which were linked to create a surface-water routing network. The gridded discretization

was similar to the approach used other models, such as PRMS (Jeton and Maurer, 2011), Topmodel (Beven and Kirkby, 1979), BCM (Flint and Flint, 2007), and GSFLOW (Markstrom and others, 2008; Woolfenden and Nishikawa, 2014), in which discretization was used to represent heterogeneities in the characteristics of the model domain. For this study, the grid-cell geometry was defined by a uniform grid spacing of 201.17 m in the north-south and east-west directions, and the grid axis was aligned according to the Universal Transverse Mercator, zone 11 projection, using the North American horizontal datum of 1983. The resulting grid covering the 503,877 ha (5,039 km<sup>2</sup>) area of the LABWM contained a total of 124,722 square grid cells, each cell covering an area of 4.04 ha.

The cascading flow-routing network, used to route runoff and seepage flow, was defined by using the average elevation of each grid cell and the standard eight-directional (D-8), convergent flow-routing method. The 10-m resolution USGS National Elevation Data (NED; [www.seamless.gov](http://www.seamless.gov)) was used to define the average elevation of each cell. The grid-cell elevations for the LABWM area ranged from a minimum of 0 m, along the coast, to a maximum of 3,033 m, in the San Gabriel Mountains (fig. 1). The elevations for grid cells in the LAGSA ranged from 0 to 500 m. Higher elevations of 201 to 600 m were outside of and next to the LAGSA in the Santa Monica Mountains, next to the northern boundary, and in the Palo Verde Hills, along the southwestern boundary (fig. 1). In general, most of the northern and northeastern LAGSA is bounded by higher elevations, creating a peripheral zone of land areas that drain into the LAGSA and likely contribute recharge, as groundwater underflow, to the LAGSA.

In the D-8 method, the flow direction for a given cell is determined by the minimum elevation of the eight adjacent cells. The flow-direction grid defines the connections between upstream and downstream cells as well as the total number of upstream cells for each cell (fig. 8). In the D-8 method, water is allowed to flow diagonally across grid corners to the four cells that are diagonally adjacent to a given cell and therefore do not share a side. For each cell, runoff and seepage is routed to only one downstream cell; however, a given cell can receive inflows from multiple upstream cells (this is also referred to as many-to-one routing). Model cells located on drainage divides do not receive inflows. In the case of cells in flat areas or depressions that are not actual closed basins, the flow direction is determined by known hydrographic features, such as stream lines and watershed divides. For the LABWM, the high-resolution 1:24,000 scale National Hydrography Data (NHD) for streams and the Los Angeles County storm-drain map were used in addition to the 10-m NED to define the flow directions to generate the D-8 grid-cell routing network (fig. 8A).

The grid-cell routing network was used to delineate the LABWM into 12 separate INFILv3 model domains (referred to as subdomains) on the basis of drainage divides and the primary drainages affecting the LAGSA (fig. 9). Eight subdomains were used to define the drainage areas most directly affecting the LAGSA (fig. 9): (1) Ballona Creek

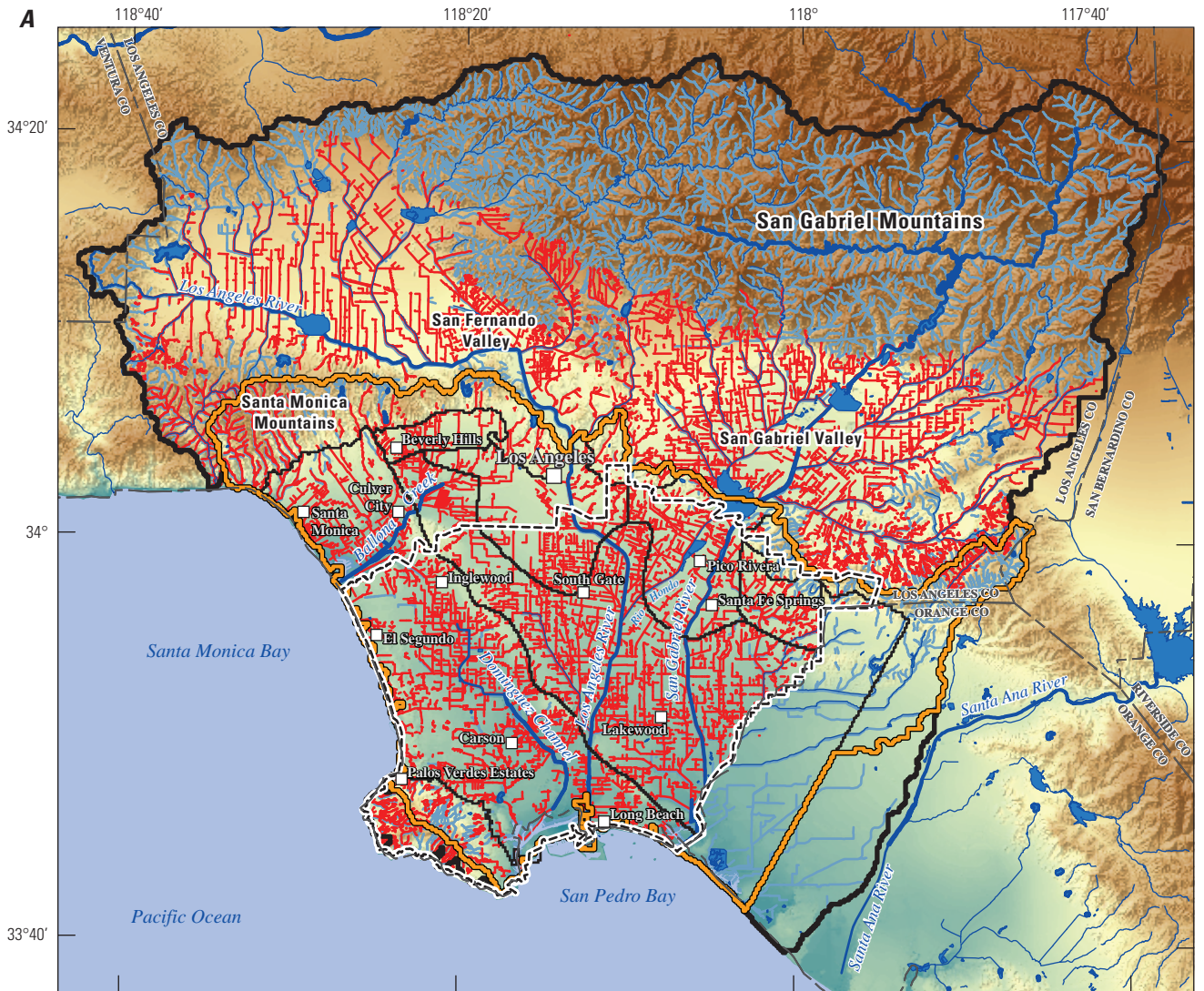
(BALC), (2) Dominguez Channel (DOMC), (3) Long Beach (LONG), (4) lower Los Angeles River (LARV), (5) lower San Gabriel River (SGRV), (6) lower Santa Monica Basin (LSMB), (7) Seal Beach (SEAL), and (8) upper Santa Monica Basin (USMB). Either all or large sections of these subdomains were included in the LAGSA and the Los Angeles recharge-study area. Three subdomains were defined by drainages upstream from the LAGSA that either were completely outside the LAGSA or only a small fraction of the total area in the LAGSA: (1) the upper drainage of the Los Angeles River (ULAR), (2) the upper drainage of the San Gabriel River (USGR), and (3) the Rio Hondo drainage (RIOH). A twelfth subdomain, Toponga Creek (TOPC), is outside of the surface-water drainages affecting the LAGSA, but was included for calibration purposes.

## Vertical Discretization

The LABWM was discretized vertically to seven layers, with layers 1 through 6 representing the root zone and an underlying seventh layer, the shallow perched zone, representing a zone of lateral groundwater flow. The discretization of the root zone into six vertical layers was done to account for differences in root density and root-zone water content with depth, as well as differences in the hydraulic conductivity between soil and bedrock. As with previous studies using INFILv3 (Hevesi and others, 2003; Rewis and others, 2006; Flint and Martin, 2012), the thickness of layers for each grid cell in the LABWM was defined on the basis of a combination of the estimated total root-zone thickness and the estimated soil thickness. The top five layers were used to represent the root zone in soil. The sixth model layer was used to represent the root zone in consolidated bedrock where there were thin soils and to designate the hydraulic conductivity of unconsolidated geologic units underlying the soil component for areas of thick soils. Following a previous INFILv3 application to estimate recharge in Big Bear Valley, California (Flint and Martin, 2012), the LABWM used a modified version of INFILv3 that includes a seventh layer representing a shallow perched zone beneath the root zone (fig. 6B).

A primary factor used to determine vertical discretization for layers 1 through 5 was soil thickness, which was estimated on the basis of maps of soils (U.S. Department of Agriculture, 1994) and surficial geology (Jennings, 1977). Areas with thick soils were defined by using the areal extent of alluvial and unconsolidated rock types. The maximum thickness of the root zone was set to 4 m for these locations. For thinner soils underlain by partially consolidated or consolidated bedrock, both the thickness of the soil layers and the underlying bedrock layer (layer 6) were based on the combination of the estimated soil thickness and the vegetation type assigned to each cell (see Rewis and others, 2006, for a more detailed description). Where soils were estimated to be thin, fewer soil layers with a thickness greater than zero were defined, and a greater thickness was assigned to layer 6 to represent the





Base modified from U.S. Geological Survey and other State digital data, various scales  
 Universal Transverse Mercator, zone 11  
 North American Datum 1983

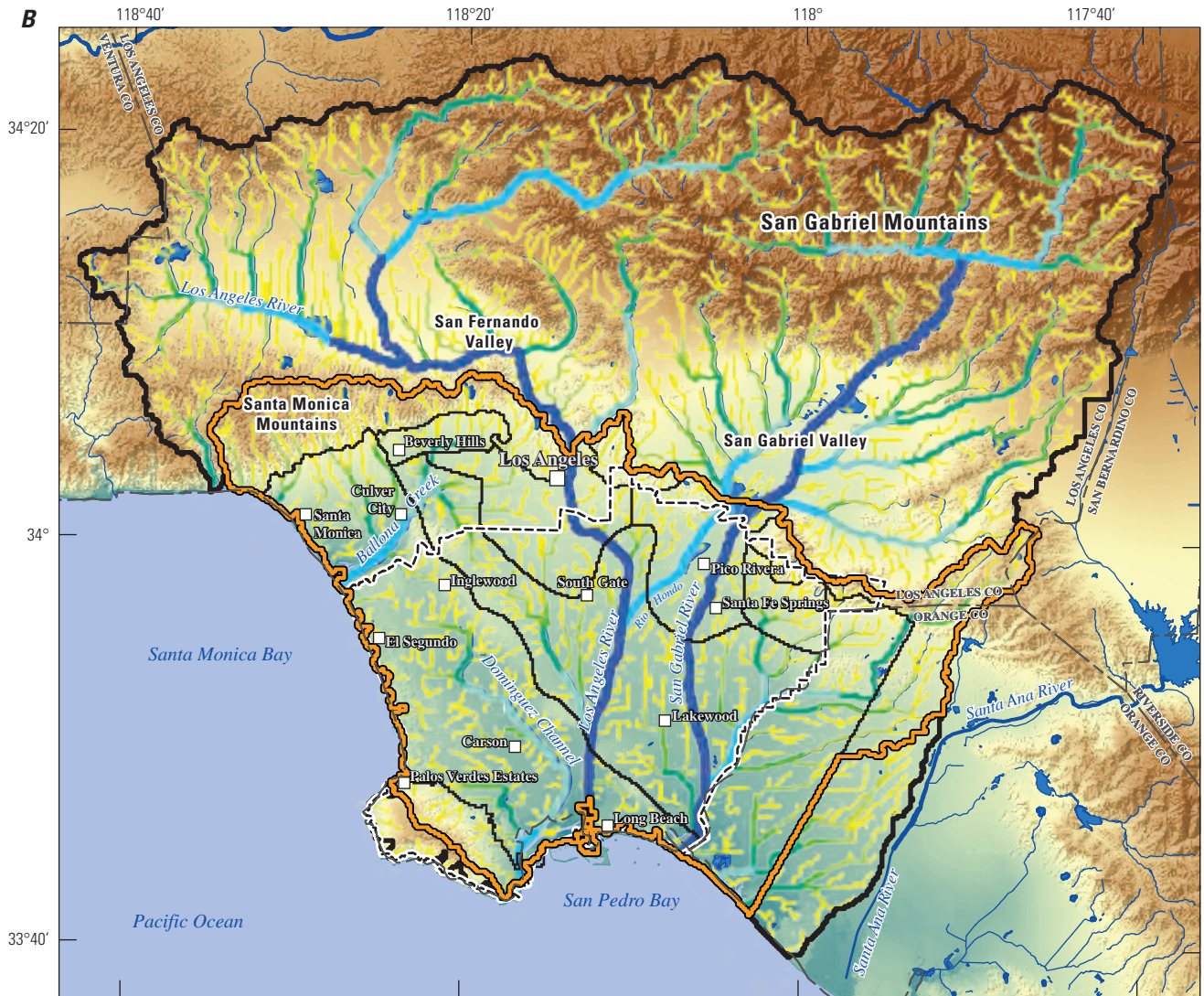


**EXPLANATION**

- Los Angeles Basin watershed model area boundary
- Water Replenishment District
- Los Angeles recharge study area
- Water bodies and flood-control areas
- Major rivers and streams
- Minor rivers and streams
- Los Angeles groundwater basins
- County line
- Los Angeles County storm drains
- National Hydrography Data streams

**Figure 8.** Grid-cell flow-routing network, Los Angeles Basin watershed model (LABWM), California: A, National Hydrography Data streams and Los Angeles County storm drains used to define the D-8 grid cell routing network; B, modeled streamlines as indicated by the number of upstream cells.





Base modified from U.S. Geological Survey and other State digital data, various scales  
 Universal Transverse Mercator, zone 11  
 North American Datum 1983

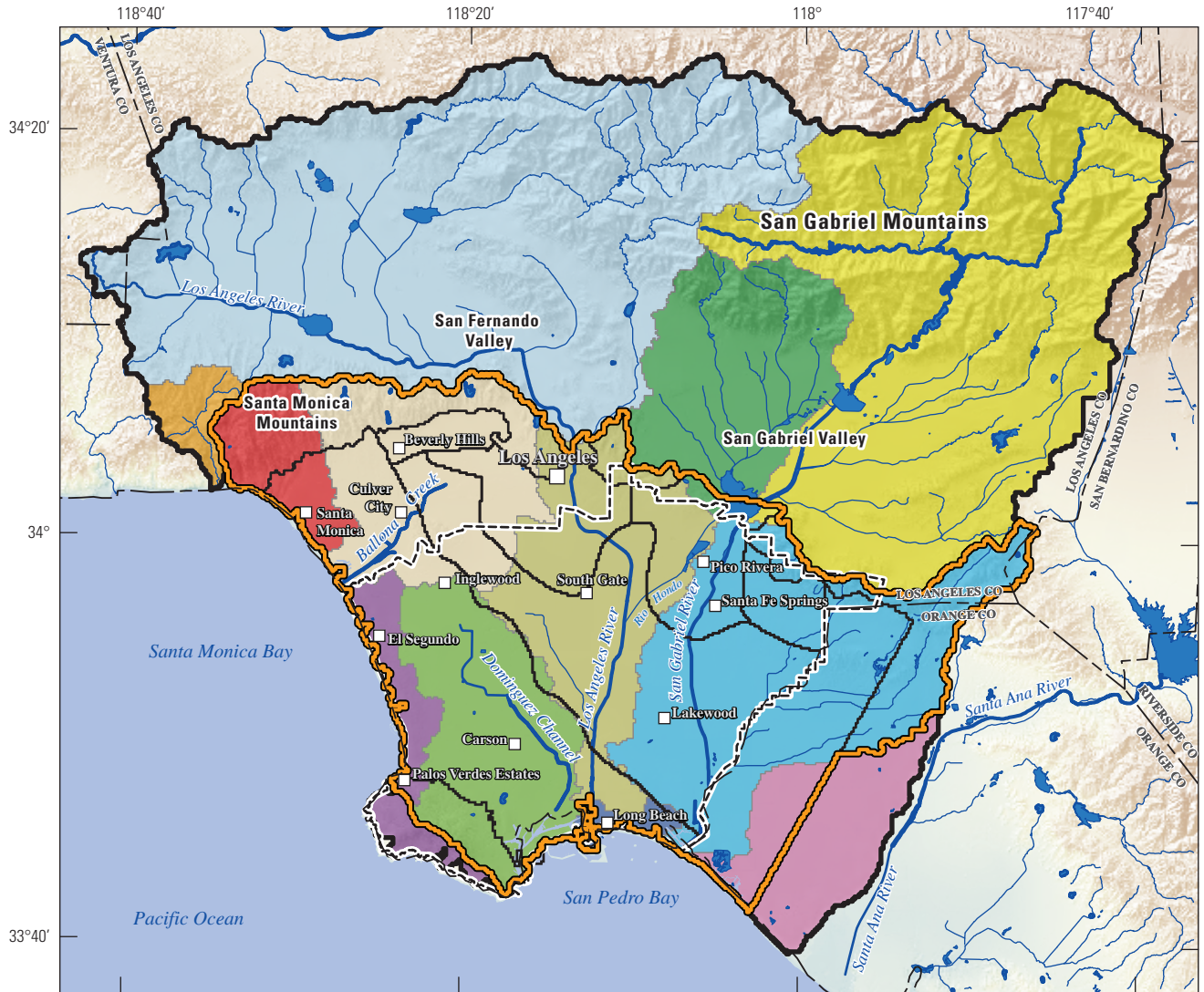


**EXPLANATION**

- Los Angeles Basin watershed model (LABWM)**  
**Modeled streamlines: number of upstream cells**
- 21–200
  - 201–500
  - 501–1,000
  - 1,001–2,000
  - 2,001–5,000
  - 5,001–10,000
  - 10,001–53,333

- Los Angeles Basin watershed model area boundary
- Water Replenishment District
- Los Angeles recharge study area
- Water bodies and flood-control areas
- Major rivers and streams
- Minor rivers and streams
- Los Angeles groundwater basins
- County line

Figure 8. —Continued



Base modified from U.S. Geological Survey and other State digital data, various scales  
 Universal Transverse Mercator, zone 11  
 North American Datum 1983



Los Angeles Basin watershed model subdomains		EXPLANATION	
Ballona Creek (BALC)	Rio Hondo (RIOH)	Los Angeles Basin watershed model area boundary	Water Replenishment District
Dominques Channel (DOMC)	Seal Beach (SEAL)	Los Angeles recharge study area	Water bodies and flood-control areas
Long Beach (LONG)	Toponga Creek (TOPC)	Major rivers and streams	Minor rivers and streams
Lower Los Angeles River (LARV)	Upper Los Angeles River (ULAR)	Los Angeles groundwater basins	County line
Lower San Gabriel River (SGRV)	Upper San Gabriel River (USGR)		
Lower Santa Monica Basin (LSMB)	Upper Santa Monica Basin (USMB)		

Figure 9. Twelve INFILv3 subdomains included in the Los Angeles Basin watershed model (LABWM), California.



extension of the root zone into bedrock (roots extending into fractures and weathered zones).

Where the thickness of layer 6 was zero, there was no transpiration from layer 6. The net-infiltration rate through the soil zone (layers 1–5), however, is limited by the upper hydraulic conductivity assigned to layer 6. Where the thickness of layer 6 was greater than 0, the consolidated-rock layer represented by layer 6 was included in the root zone, and transpiration from layer 6 was simulated.

The thickness of the perched zone (layer 7) was dependent on the rock type and was defined by dividing the estimated storage capacity of the perched zone (0.6096 m) by the effective porosity estimated for layer 6 (layers 6 and 7 were assumed to be the same rock type underlying the root zone). The storage capacities of the six root-zone layers and the perched-zone layer were calculated by using layer thickness and the estimated layer porosity. The storage capacities were expressed as a uniform depth and defined the maximum amount of water stored in each layer and available for ET. Layer thicknesses and storage capacities are discussed in more detail in the “Model Inputs” section.

## Spatially Distributed Model Parameters

Spatially distributed watershed parameters represent the physical characteristics of the drainages being modeled, including the land surface, the root zone, and the shallow perched zone. Spatially distributed parameters included (1) topographic parameters, (2) land-cover parameters, (3) vegetation and root-zone parameters, (4) soil parameters, and (5) geohydrologic parameters.

## Topographic Parameters

In addition to the grid-cell elevations and flow-routing parameters discussed previously, the topographic parameters included a set of parameters required for the simulation of PET. The topographic parameters included land-surface slope, aspect, a set of 36 blocking ridge angles, and a skyview parameter. Elevation, slope, aspect, and shading parameters were used to simulate incoming solar radiation and the net-radiation energy balance on an hourly basis, which was then used to simulate PET (Flint and Childs, 1987). Cell elevation was also used to simulate seepage flow. The 36 blocking ridge angles were calculated at each 10 degree azimuth direction for each cell and were used to model the effects of shading from surrounding terrain, which can greatly reduce PET in rugged areas (Flint and Childs, 1987). The blocking ridge angles defined the sunrise and sunset times for the 1-hour time step used in the PET simulation. The blocking ridge angles were used to calculate the skyview parameter, which defined

the reduction in refracted clear-sky solar radiation caused by the surrounding terrain. In general, simulated PET was much less for higher elevation, north-facing slopes compared to lower elevation, south-facing slopes, and PET was greater for summit areas compared to valleys surrounded by high ridges.

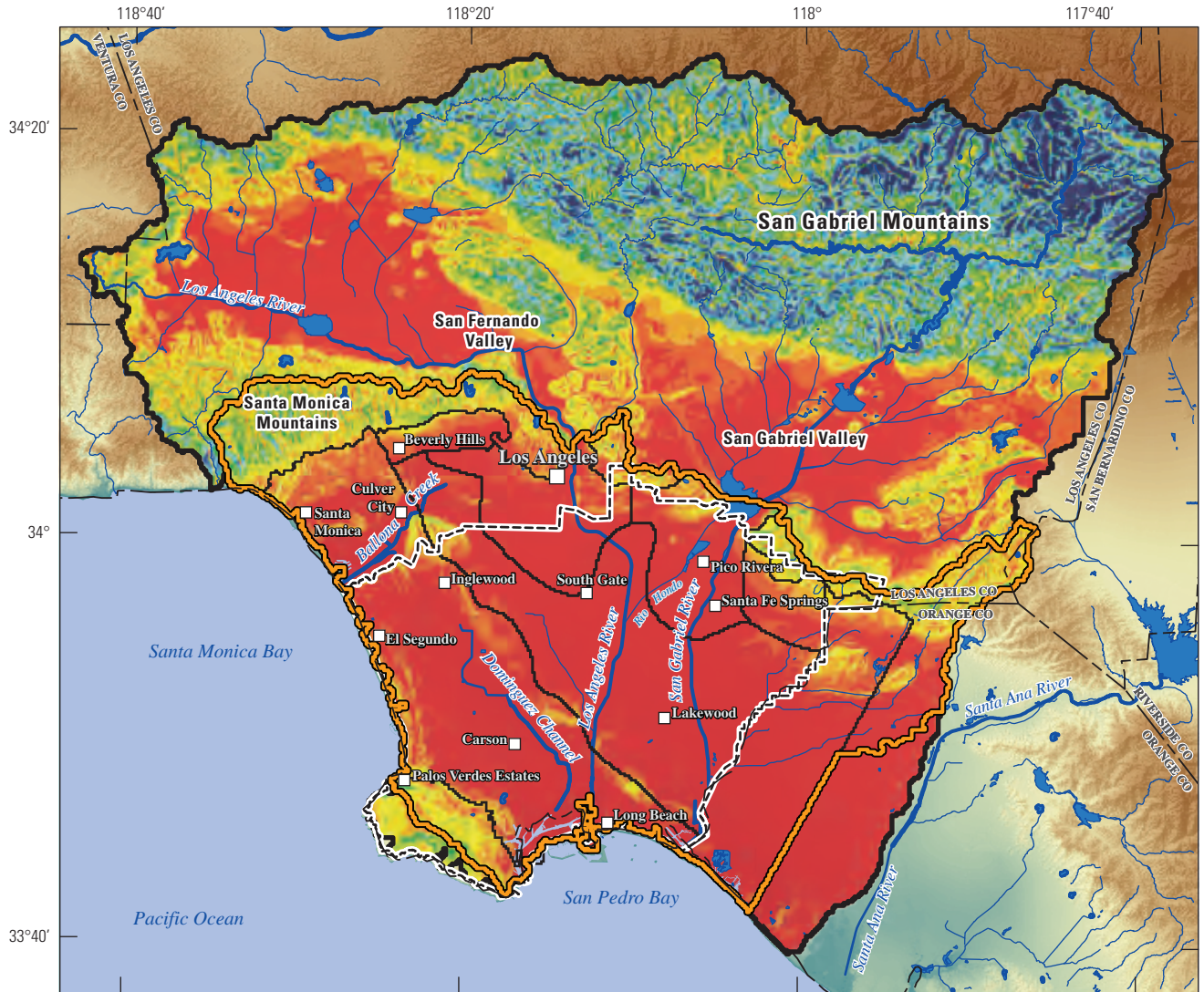
The 10-meter resolution USGS NED data (<http://www.seamless.gov>) used to develop the flow-routing network were also used to define the topographic parameters for each grid cell. Land-surface slope and aspect were calculated by using GIS as the average slope and aspect of all 10-meter NED cells in the area of each 201-m LABWM cell (figs. 10, 11). The calculated slope ranged from a minimum of 0 degrees, for many cells in the Los Angeles Basin, to a maximum slope of 41.3 degrees, in the San Gabriel Mountains (fig. 10). The average slope for the LABWM area was 6.3 degrees. Almost half of all cells either had an aspect in the range of 157.51 to 202.5 degrees (south), calculated for 25 percent of all cells, or in the range of 202.51 to 247.5 degrees (southwest), calculated for 22 percent of all cells in the LABWM area (fig. 11).

## Land Cover Parameters

Input for the LABWM included two parameters representing land-cover characteristics: (1) percentage of imperviousness and (2) percentage of plant-canopy cover (vegetation density). The imperviousness percentage is defined as the percentage of the cell area that was covered by an artificial impervious surface (for example, a roadway, rooftop, or parking lot). The average imperviousness was estimated by using the 2001 National Land Cover Data (NLCD), which has a grid resolution of 30 m (U.S. Geological Survey, 2005). The average imperviousness for the LABWM domain was 33.7 percent (fig. 12). Maximum imperviousness values of 99 percent were obtained for the highly developed areas, such as downtown Los Angeles. Minimum values of 0 percent imperviousness were obtained for the mountainous headwater regions in the San Gabriel and Santa Monica Mountains.

Estimates of the percentage of plant-canopy cover were calculated by using the 2001 NLCD 30-meter forest-canopy map (U.S. Geological Survey, 2001). The percentage of canopy cover is defined as the percentage of land area covered by natural forest canopy. Forest canopy does not represent urban or agricultural landscapes. A maximum forest canopy cover of 73 percent was obtained for the San Gabriel Mountains, and an average value of 9.7 percent was obtained for the LABWM area (fig. 13). Forest-canopy values of 0 percent were obtained for most of the developed and urbanized lowland areas of the Los Angeles Basin and the San Fernando Valley, including much of the area in the Los Angeles recharge-study area (area contributing recharge to the LAGSA).



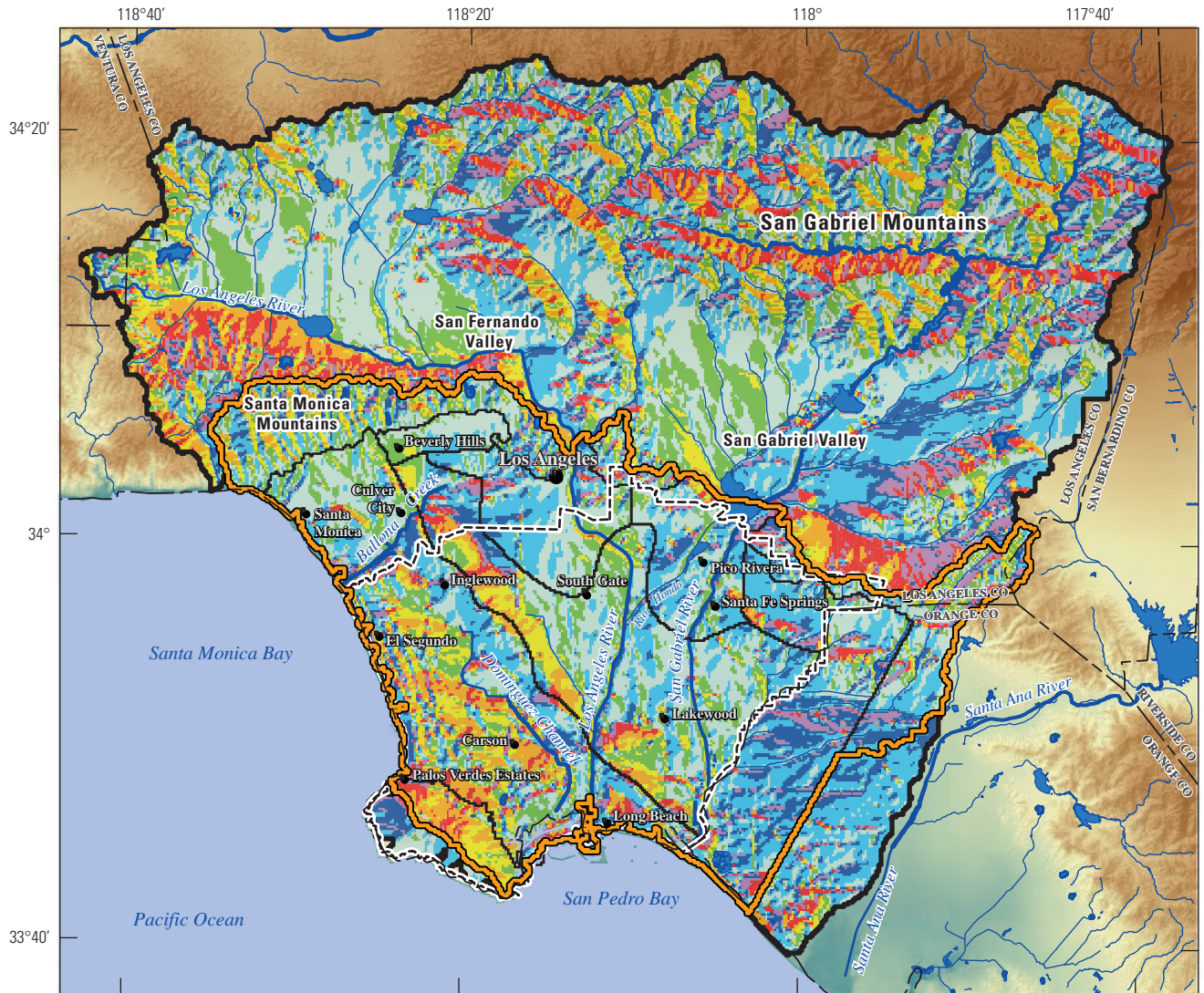


Base modified from U.S. Geological Survey and other State digital data, various scales  
 Universal Transverse Mercator, zone 11  
 North American Datum 1983



Land-surface slope (in degrees)		EXPLANATION	
<span style="color: red;">■</span> 0.0–1.0	<span style="color: green;">■</span> 12.1–16.0	<span style="border: 2px solid black; display: inline-block; width: 15px; height: 10px;"></span> Los Angeles Basin watershed model area boundary	<span style="border: 1px dashed black; display: inline-block; width: 15px; height: 10px;"></span> Water Replenishment District
<span style="color: orange;">■</span> 1.1–2.0	<span style="color: lightgreen;">■</span> 16.1–20.0	<span style="border: 2px solid orange; display: inline-block; width: 15px; height: 10px;"></span> Los Angeles recharge study area	<span style="background-color: blue; display: inline-block; width: 15px; height: 10px;"></span> Water bodies and flood-control areas
<span style="color: yellow;">■</span> 2.1–4.0	<span style="color: cyan;">■</span> 20.1–24.0	<span style="color: blue;">—</span> Major rivers and streams	<span style="color: blue;">—</span> Minor rivers and streams
<span style="color: lightyellow;">■</span> 4.1–8.0	<span style="color: darkblue;">■</span> 24.1–28.0	<span style="border-bottom: 1px solid black; width: 15px; display: inline-block;"></span> Los Angeles groundwater basins	<span style="border-bottom: 1px dashed black; width: 15px; display: inline-block;"></span> County line
<span style="color: limegreen;">■</span> 8.1–12.0	<span style="color: navy;">■</span> 28.1–41.0		

Figure 10. Average land-surface slope, Los Angeles Basin watershed model (LABWM), California.



Base modified from U.S. Geological Survey and other State digital data, various scales  
 Universal Transverse Mercator, zone 11  
 North American Datum 1983

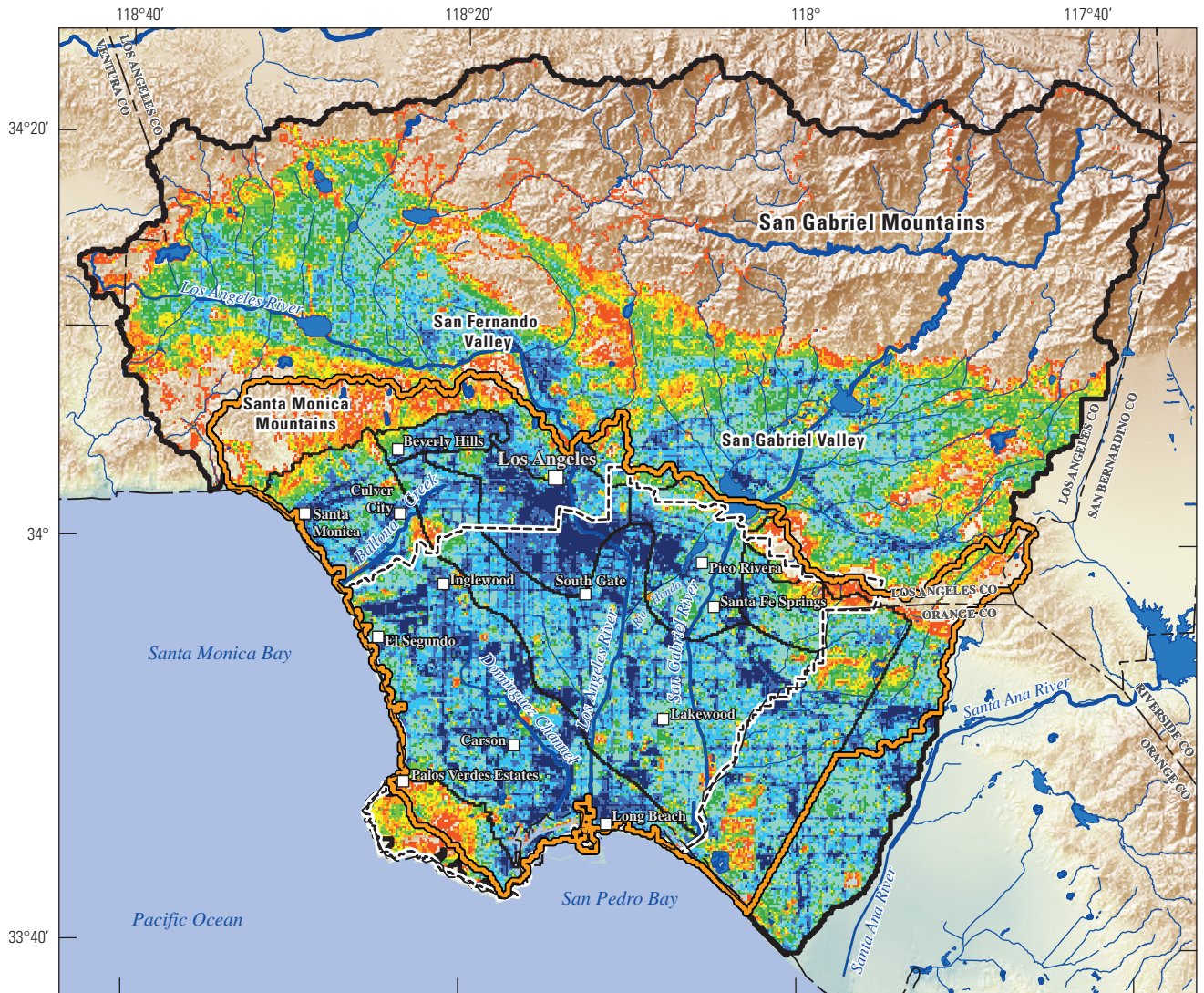


**EXPLANATION**

<b>Land-surface aspect (in degrees)</b>		Los Angeles Basin watershed model area boundary
North (0–22.50)	Southwest (202.51–247.50)	Water Replenishment District
Northeast (22.51–67.50)	West (247.51–292.50)	Los Angeles recharge study area
East (67.51–112.50)	Northwest (292.51–337.50)	Water bodies and flood-control areas
Southeast (112.51–157.50)	North (337.51–360.00)	Major rivers and streams
South (157.51–202.50)		Minor rivers and streams
		Los Angeles groundwater basins
		County line

Figure 11. Average land-surface aspect, Los Angeles Basin watershed model (LABWM), California.



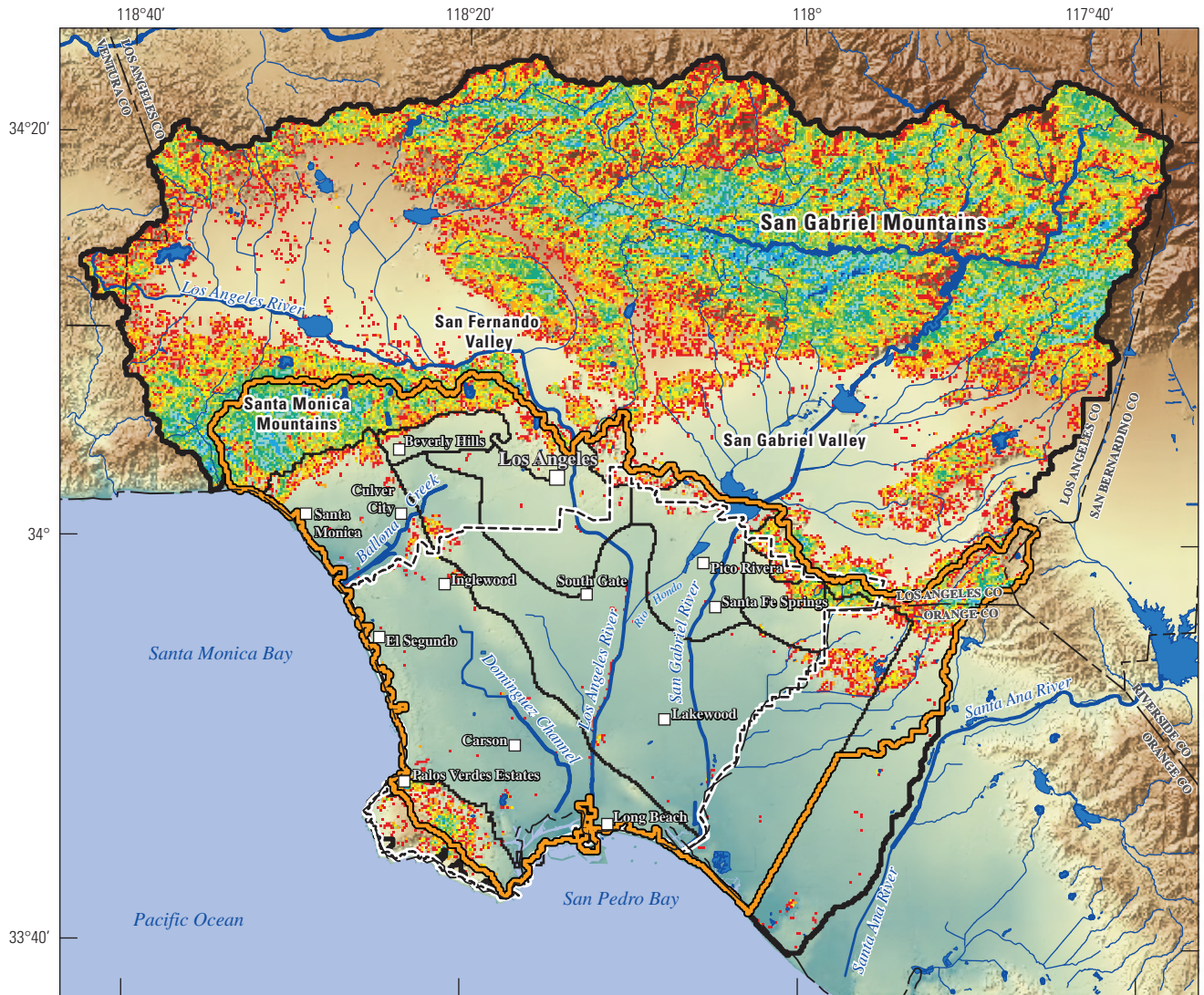


Base modified from U.S. Geological Survey and other Federal and State digital data, various scales  
 Universal Transverse Mercator, zone 11  
 North American Datum 1983



Impervious area, in percent		EXPLANATION	
<span style="display:inline-block; width:15px; height:15px; background-color:orange;"></span> 1-10	<span style="display:inline-block; width:15px; height:15px; background-color:lightgreen;"></span> 51-60	<span style="display:inline-block; border:2px solid black; width:15px; height:15px;"></span> Los Angeles Basin watershed model area boundary	<span style="display:inline-block; border:1px dashed black; width:15px; height:15px;"></span> Water Replenishment District
<span style="display:inline-block; width:15px; height:15px; background-color:yellow;"></span> 11-20	<span style="display:inline-block; width:15px; height:15px; background-color:lightblue;"></span> 61-70	<span style="display:inline-block; border:2px solid orange; width:15px; height:15px;"></span> Los Angeles recharge study area	<span style="display:inline-block; width:15px; height:15px; background-color:blue;"></span> Water bodies and flood-control areas
<span style="display:inline-block; width:15px; height:15px; background-color:yellow;"></span> 21-30	<span style="display:inline-block; width:15px; height:15px; background-color:darkblue;"></span> 71-80	<span style="display:inline-block; width:15px; height:15px; background-color:blue;"></span> Major rivers and streams	<span style="display:inline-block; width:15px; height:15px; background-color:lightblue;"></span> Minor rivers and streams
<span style="display:inline-block; width:15px; height:15px; background-color:lightgreen;"></span> 31-40	<span style="display:inline-block; width:15px; height:15px; background-color:darkblue;"></span> 81-99	<span style="display:inline-block; border-bottom:1px solid black; width:15px;"></span> Los Angeles groundwater basins	<span style="display:inline-block; border-bottom:1px dashed black; width:15px;"></span> County line
<span style="display:inline-block; width:15px; height:15px; background-color:green;"></span> 41-50			

Figure 12. Percentage of impervious area, Los Angeles Basin watershed model (LABWM), California.



Base modified from U.S. Geological Survey and other Federal and State digital data, various scales  
 Universal Transverse Mercator, zone 11  
 North American Datum 1983



Forest canopy cover, in percent		EXPLANATION	
<span style="display:inline-block; width:15px; height:15px; background-color:red; border:1px solid black;"></span> 1-8	<span style="display:inline-block; width:15px; height:15px; background-color:teal; border:1px solid black;"></span> 41-48	<span style="display:inline-block; border:2px solid black; width:15px; height:15px;"></span> Los Angeles Basin watershed model area boundary	<span style="display:inline-block; border:1px dashed black; width:15px; height:15px;"></span> Water Replenishment District
<span style="display:inline-block; width:15px; height:15px; background-color:orange; border:1px solid black;"></span> 9-16	<span style="display:inline-block; width:15px; height:15px; background-color:lightblue; border:1px solid black;"></span> 49-56	<span style="display:inline-block; border:2px solid orange; width:15px; height:15px;"></span> Los Angeles recharge study area	<span style="display:inline-block; background-color:blue; width:15px; height:15px;"></span> Water bodies and flood-control areas
<span style="display:inline-block; width:15px; height:15px; background-color:yellow; border:1px solid black;"></span> 17-24	<span style="display:inline-block; width:15px; height:15px; background-color:lightgreen; border:1px solid black;"></span> 57-64	<span style="display:inline-block; width:15px; height:15px; background-color:blue;"></span> Major rivers and streams	<span style="display:inline-block; width:15px; height:15px; background-color:lightblue;"></span> Minor rivers and streams
<span style="display:inline-block; width:15px; height:15px; background-color:lightgreen; border:1px solid black;"></span> 25-32	<span style="display:inline-block; width:15px; height:15px; background-color:darkblue; border:1px solid black;"></span> 65-73	<span style="display:inline-block; border-bottom:1px solid black; width:15px;"></span> Los Angeles groundwater basins	<span style="display:inline-block; border-bottom:1px dashed black; width:15px;"></span> County line
<span style="display:inline-block; width:15px; height:15px; background-color:green; border:1px solid black;"></span> 33-40			

Figure 13. Percentage of forest-canopy cover, Los Angeles Basin watershed model (LABWM), California.



## Vegetation and Root-Zone Parameters

Vegetation and land-use type were used to help define the thickness of root-zone layer 6 and root density for all layers of the root zone. In general, a thicker root zone and greater root densities are assigned to denser vegetation types (for example, forested areas and residential urban areas). Vegetation and land-use types were defined by using the California Land Cover Mapping and Monitoring Program (CLCMMP) whrtyp vegetation data ([http://frap.cdf.ca.gov/projects/land\\_cover/index.html](http://frap.cdf.ca.gov/projects/land_cover/index.html)). The whrtyp attribute used by the CLCMMP is based on the California Wildlife Habitat Relationships System (CWHHR) classification of existing vegetation types important to wildlife (<http://www.dfg.ca.gov/biogeodata/>). This system was developed to recognize and logically categorize major plant communities at a scale sufficient to predict wildlife-habitat relationships (California Department of Fish and Wildlife, 2014). A total of 31 different vegetation and land-use types were identified for the LABWM domain (fig. 14; table 5). The most common vegetation and land-use types were urban (map number 8), assigned to 73,864 cells, and mixed chaparral (map number 1), assigned to 22,103 cells. The least common vegetation type was wet meadow (map number 19), assigned to one cell.

## Soil Parameters

Soil parameters were estimated for each model cell by using the State Soil Geographic Database (STATSGO) digital map and associated attribute tables compiled by the U.S. Department of Agriculture (1994). A total of 18 different soil types, or soil map units, were defined by the STATSGO data (fig. 15; table 6). The soil parameters included several physical and hydraulic properties based on the STATSGO data (Hevesi and others, 2003): soil porosity, wilting-point (residual) water content, soil depth, a drainage-function coefficient, and vertical saturated hydraulic conductivity. Soil depth, porosity, and the wilting point defined the root-zone storage capacities that were used to simulate transpiration from the five soil layers. The relative saturation of each root-zone layer—calculated by using the simulated water content and the maximum storage capacity of each layer—along with the vertical saturated hydraulic conductivity and the drainage-function coefficient for each layer were used to simulate drainage and ET for each layer.

The soil parameters used in the LABWM were the weighted average values of the soil components and layers associated with each STATSGO map-unit identifier (MUID). The MUID assigned to each LABWM cell was the MUID with the maximum area within each cell. For the LABWM domain, the maximum soil porosity was 0.43, and minimum porosity was 0.35 (table 6). The porosities of 0.4 and greater were in the area of the Palos Verdes Hills and in the higher

elevations of the San Gabriel and Santa Ana Mountains. These higher porosities were likely due to more organic matter in these soils, which were generally in the more heavily vegetated areas. The lowest porosities, 0.348 to 0.35, were along the coastal region of the Los Angeles Basin and were likely associated with soils that had a high percentage of sand. The maximum and minimum wilting-point values were 0.18 and 0.01, respectively (table 6). The upper vertical saturated hydraulic conductivity values varied from a maximum of 5,747 millimeters per day (mm/day) to a minimum of 202 mm/day, and the lower vertical saturated hydraulic conductivity varied from a maximum of 1,280 mm/day to a minimum of 70 mm/day (table 6). The soils with higher hydraulic conductivities were in the coastal areas (where the soils are likely sandier) and in the higher elevations of the San Gabriel Mountains.

## Geohydrologic Parameters

Parameters representing the geohydrologic properties of geologic materials (consolidated and unconsolidated rock types) underlying the soil zone were estimated for each of the 24 different geologic map units defined by Jennings (1977) that are in the LABWM area (fig. 16; table 7). The parameters included layer-6 effective porosity, layer-6 upper and lower saturated hydraulic conductivity, and layer-7 hydraulic conductivity and thickness (table 7). Estimates of effective porosity and upper and lower saturated hydraulic conductivity were based on a general knowledge of the characteristics of the different geologic units. For example, unconsolidated deposits were assumed to have a greater effective porosity and saturated hydraulic conductivity compared to consolidated rocks, and sedimentary rocks were assumed to have greater saturated hydraulic conductivity relative to igneous and metamorphic rocks (Hevesi and others, 2003; Flint and Martin, 2012). The thickness of the shallow, perched-groundwater zone (layer 7) was defined by assuming a storage capacity of 0.6096 m and then using the estimated effective porosity to calculate a thickness for layer 7.

The combined thickness of root-zone layers 1 through 5 was defined by the estimated soil thickness. Soil thickness first was estimated by using the map of surficial geology (indicating consolidated-rock types and unconsolidated sediments) to locate unconsolidated sediments (mostly alluvium), which were associated with thick soils. The root-zone soil thickness was set to 4 m for thick soils. The STATSGO soil-type map then was used to define the soil thickness for all areas mapped as a consolidated-rock type. The resulting soil-thickness map varied from minimum values of less than 0.3 m in rugged, upland areas to maximum values of 1.5–4 m in the low-lying areas mapped as having thick alluvium (fig. 17).



Base modified from U.S. Geological Survey and other State digital data, various scales  
 Universal Transverse Mercator, zone 11  
 North American Datum 1983



**EXPLANATION**

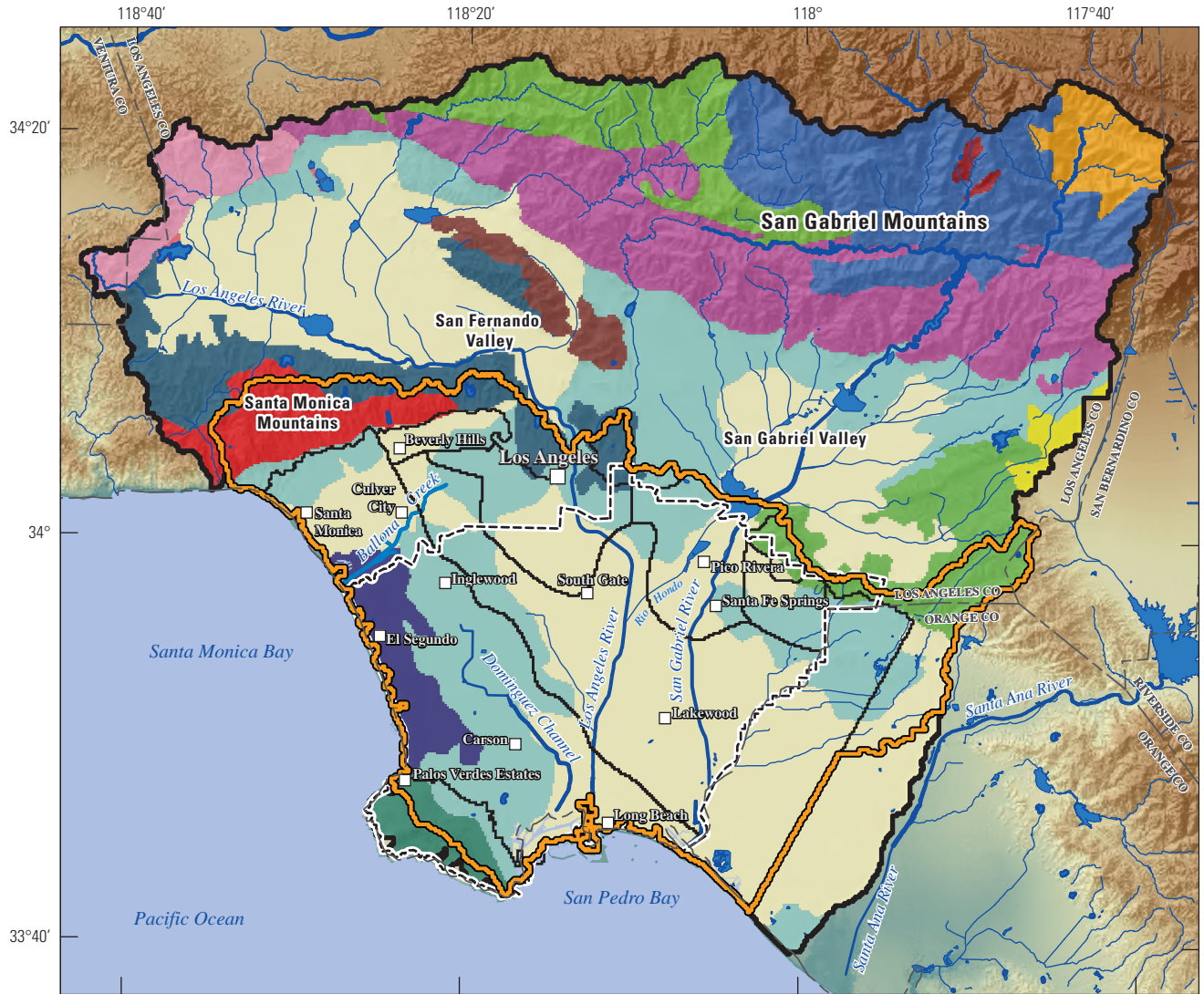
- |   |   |  |  |
|---|---|--|--|
| <b>Vegetation and land-cover classification</b>   |   |  | <ul style="list-style-type: none"> <li><span style="border: 1px solid black; display: inline-block; width: 15px; height: 10px; margin-right: 5px;"></span> Los Angeles Basin watershed model area boundary</li> <li><span style="border: 1px dashed black; display: inline-block; width: 15px; height: 10px; margin-right: 5px;"></span> Water Replenishment District</li> <li><span style="border: 2px solid orange; display: inline-block; width: 15px; height: 10px; margin-right: 5px;"></span> Los Angeles recharge study area</li> <li><span style="background-color: blue; display: inline-block; width: 15px; height: 10px; margin-right: 5px;"></span> Water bodies and flood-control areas</li> <li><span style="border-bottom: 1px solid blue; display: inline-block; width: 15px; margin-right: 5px;"></span> Major rivers and streams</li> <li><span style="border-bottom: 1px solid lightblue; display: inline-block; width: 15px; margin-right: 5px;"></span> Minor rivers and streams</li> <li><span style="border-bottom: 1px solid black; display: inline-block; width: 15px; margin-right: 5px;"></span> Los Angeles groundwater basins</li> <li><span style="border-bottom: 1px dashed black; display: inline-block; width: 15px; margin-right: 5px;"></span> County line</li> </ul> |
| <ul style="list-style-type: none"> <li><span style="background-color: #90EE90; display: inline-block; width: 15px; height: 10px; margin-right: 5px;"></span> Mixed chaparral</li> <li><span style="background-color: #800080; display: inline-block; width: 15px; height: 10px; margin-right: 5px;"></span> Chamise-redshank chaparral</li> <li><span style="background-color: #FF4500; display: inline-block; width: 15px; height: 10px; margin-right: 5px;"></span> Coastal oak woodland</li> <li><span style="background-color: #00BFFF; display: inline-block; width: 15px; height: 10px; margin-right: 5px;"></span> Annual grass</li> <li><span style="background-color: #FFD700; display: inline-block; width: 15px; height: 10px; margin-right: 5px;"></span> Coastal scrub</li> <li><span style="background-color: #8B4513; display: inline-block; width: 15px; height: 10px; margin-right: 5px;"></span> Barren</li> <li><span style="background-color: #654321; display: inline-block; width: 15px; height: 10px; margin-right: 5px;"></span> Valley oak woodland</li> <li><span style="background-color: #FFFF00; display: inline-block; width: 15px; height: 10px; margin-right: 5px;"></span> Urban</li> <li><span style="background-color: #90EE90; display: inline-block; width: 15px; height: 10px; margin-right: 5px;"></span> Montane riparian</li> <li><span style="background-color: #008000; display: inline-block; width: 15px; height: 10px; margin-right: 5px;"></span> Water</li> </ul> | <ul style="list-style-type: none"> <li><span style="background-color: #ADD8E6; display: inline-block; width: 15px; height: 10px; margin-right: 5px;"></span> Agriculture-crops</li> <li><span style="background-color: #4169E1; display: inline-block; width: 15px; height: 10px; margin-right: 5px;"></span> Unknown</li> <li><span style="background-color: #191970; display: inline-block; width: 15px; height: 10px; margin-right: 5px;"></span> Saline emergent wetland</li> <li><span style="background-color: #DC143C; display: inline-block; width: 15px; height: 10px; margin-right: 5px;"></span> Desert wash</li> <li><span style="background-color: #008080; display: inline-block; width: 15px; height: 10px; margin-right: 5px;"></span> Valley foothill riparian</li> <li><span style="background-color: #9370DB; display: inline-block; width: 15px; height: 10px; margin-right: 5px;"></span> Eucalyptus</li> <li><span style="background-color: #9ACD32; display: inline-block; width: 15px; height: 10px; margin-right: 5px;"></span> Perennial grass</li> <li><span style="background-color: #FF69B4; display: inline-block; width: 15px; height: 10px; margin-right: 5px;"></span> Montane hardwood</li> <li><span style="background-color: #32CD32; display: inline-block; width: 15px; height: 10px; margin-right: 5px;"></span> Wet meadow</li> <li><span style="background-color: #8B4513; display: inline-block; width: 15px; height: 10px; margin-right: 5px;"></span> Desert scrub</li> </ul> | <ul style="list-style-type: none"> <li><span style="background-color: #3CB371; display: inline-block; width: 15px; height: 10px; margin-right: 5px;"></span> Eastside pine</li> <li><span style="background-color: #DDA0DD; display: inline-block; width: 15px; height: 10px; margin-right: 5px;"></span> Jeffrey pine</li> <li><span style="background-color: #191970; display: inline-block; width: 15px; height: 10px; margin-right: 5px;"></span> Montane hardwood conifer</li> <li><span style="background-color: #483D8B; display: inline-block; width: 15px; height: 10px; margin-right: 5px;"></span> Montane chaparral</li> <li><span style="background-color: #2F4F4F; display: inline-block; width: 15px; height: 10px; margin-right: 5px;"></span> Sierran mixed conifer</li> <li><span style="background-color: #C08060; display: inline-block; width: 15px; height: 10px; margin-right: 5px;"></span> Sagebrush</li> <li><span style="background-color: #3CB371; display: inline-block; width: 15px; height: 10px; margin-right: 5px;"></span> Ponderosa pine</li> <li><span style="background-color: #800080; display: inline-block; width: 15px; height: 10px; margin-right: 5px;"></span> Subalpine conifer</li> <li><span style="background-color: #FF8C00; display: inline-block; width: 15px; height: 10px; margin-right: 5px;"></span> Freshwater emergent wetland</li> <li><span style="background-color: #4682B4; display: inline-block; width: 15px; height: 10px; margin-right: 5px;"></span> Closed cone pine-cypress</li> <li><span style="background-color: #6A5ACD; display: inline-block; width: 15px; height: 10px; margin-right: 5px;"></span> Alkali scrub</li> </ul> |  |

**Figure 14.** Vegetation type, Los Angeles Basin watershed model (LABWM), California.



**Table 5.** Table of vegetation parameters (layers 1–6), Los Angeles Basin watershed model (LABWM), California.

Vegetation and land use classification	Root densities (percent)						Layer 6 maximum thickness (meters)
	Layer 1	Layer 2	Layer 3	Layer 4	Layer 5	Layer 6	
MIXED CHAPARRAL	50	50	50	50	40	40	4
CHAMISE-REDSHANK CHAPARRAL	50	50	50	50	40	30	2
COASTAL OAK WOODLAND	70	70	70	60	50	50	4
ANNUAL GRASS	70	70	50	40	20	10	3
COASTAL SCRUB	50	50	40	40	30	20	4
BARREN	10	10	10	5	2	1	2
VALLEY OAK WOODLAND	80	80	80	60	60	50	2
URBAN	90	90	90	90	90	90	2
MONTANE RIPARIAN	90	90	90	80	70	50	2
WATER	0	0	0	0	0	0	2
AGRICULTURE-CROPS	90	90	50	30	20	5	2
UNKOWN	50	50	50	50	50	50	2
SALINE EMERGENT WETLAND	50	50	50	50	50	50	2
DESERT WASH	50	50	50	50	50	50	2
VALLEY FOOTHIL RIPARIAN	50	50	50	50	50	50	2
EUCALYPTUS	80	80	80	80	70	60	2
PERENNIAL GRASS	90	80	50	40	20	5	2
MONTANE HARDWOOD	80	80	80	80	70	70	2
WET MEADOW	90	90	90	90	90	90	2
DESERT SCRUB	50	50	50	50	30	30	2
EASTSIDE PINE	70	70	70	60	50	40	2
JEFFREY PINE	70	70	70	60	60	50	2
MONTANE HARDWOODS CONIFER	80	80	80	70	60	50	2
MONTANE CHAPARRAL	60	60	50	50	40	30	2
SIERRAN MIXED CONIFER	70	70	70	60	50	50	2
SAGEBRUSH	50	50	50	50	40	40	2
PONDEROSA PINE	70	70	70	70	60	50	2
SUBALPINE CONIFER	60	60	60	60	50	50	2
FRESHWATER EMERGENT WETLAN	90	90	90	90	80	70	2
CLOSED CONE PINE-CYPRESS	60	60	60	60	50	50	2
ALKALI SCRUB	40	40	40	40	40	40	2



Base modified from U.S. Geological Survey and other Federal and State digital data, various scales  
 Universal Transverse Mercator, zone 11  
 North American Datum 1983



**EXPLANATION**

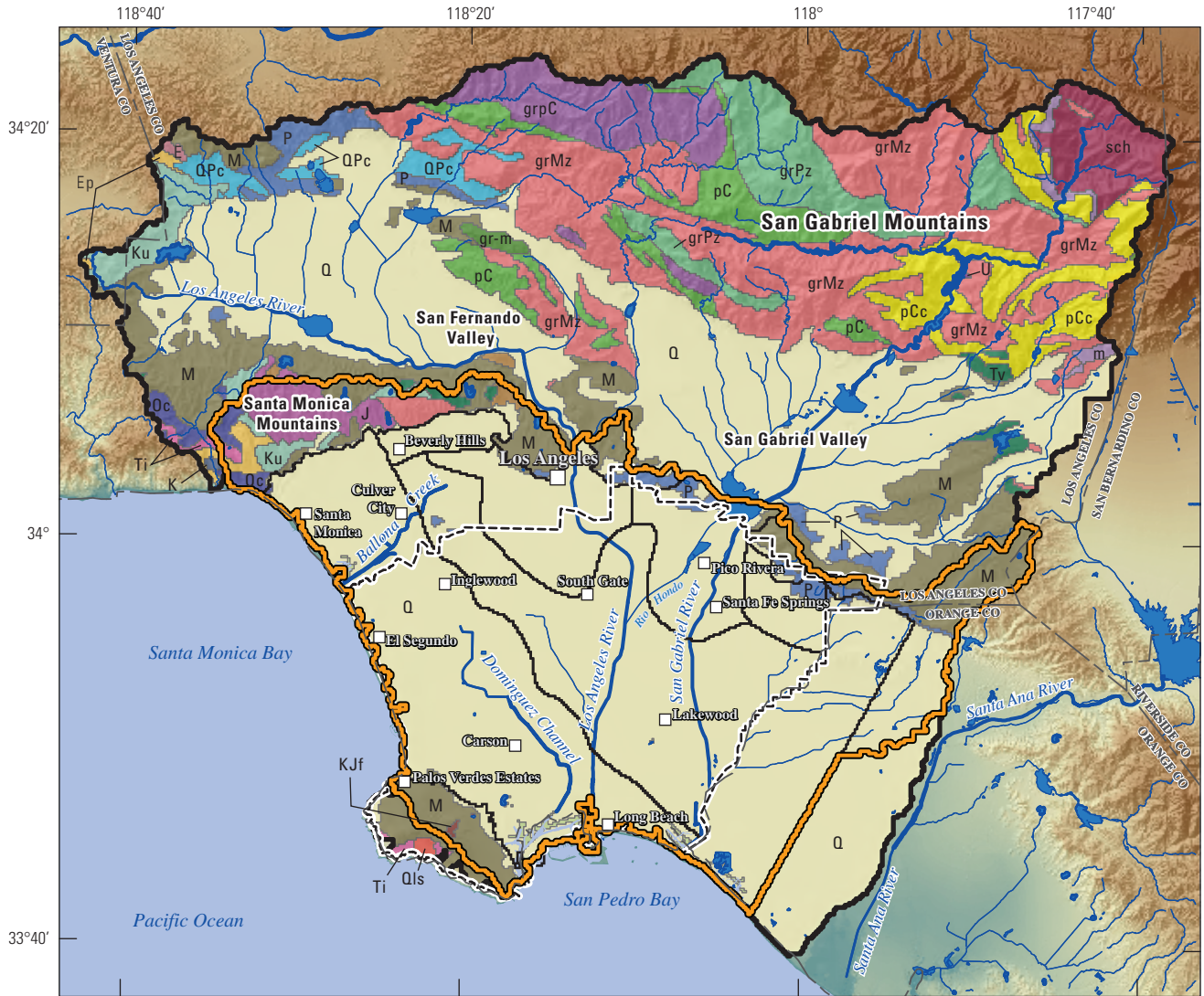
STATSGO map unit identifier (MUID)			
<span style="display:inline-block; width:15px; height:15px; background-color:#90EE90;"></span> CA520	<span style="display:inline-block; width:15px; height:15px; background-color:#ADD8E6;"></span> CA645	<span style="display:inline-block; width:15px; height:15px; background-color:#2E8B57;"></span> CA641	<span style="border: 1px solid black; display:inline-block; width:15px; height:15px;"></span> Los Angeles Basin watershed model area boundary
<span style="display:inline-block; width:15px; height:15px; background-color:#6A5ACD;"></span> CA523	<span style="display:inline-block; width:15px; height:15px; background-color:#FF0000;"></span> CA647	<span style="display:inline-block; width:15px; height:15px; background-color:#800080;"></span> CA672	<span style="border: 1px dashed black; display:inline-block; width:15px; height:15px;"></span> Water Replenishment District
<span style="display:inline-block; width:15px; height:15px; background-color:#F08080;"></span> CA990	<span style="display:inline-block; width:15px; height:15px; background-color:#FFFF00;"></span> CA638	<span style="display:inline-block; width:15px; height:15px; background-color:#90EE90;"></span> CA677	<span style="border: 2px solid orange; display:inline-block; width:15px; height:15px;"></span> Los Angeles recharge study area
<span style="display:inline-block; width:15px; height:15px; background-color:#2F4F4F;"></span> CA655	<span style="display:inline-block; width:15px; height:15px; background-color:#FFFF00;"></span> CA639	<span style="display:inline-block; width:15px; height:15px; background-color:#FFB6C1;"></span> CA522	<span style="display:inline-block; width:15px; height:15px; background-color:#0000FF;"></span> Water bodies and flood-control areas
<span style="display:inline-block; width:15px; height:15px; background-color:#FFA500;"></span> CA671	<span style="display:inline-block; width:15px; height:15px; background-color:#191970;"></span> CA640	<span style="display:inline-block; width:15px; height:15px; background-color:#4169E1;"></span> CA676	<span style="display:inline-block; width:15px; height:15px; background-color:#000000;"></span> Major rivers and streams
<span style="display:inline-block; width:15px; height:15px; background-color:#8B0000;"></span> CA665	<span style="display:inline-block; width:15px; height:15px; background-color:#32CD32;"></span> CA642	<span style="display:inline-block; width:15px; height:15px; background-color:#654321;"></span> CA622	<span style="display:inline-block; width:15px; height:15px; background-color:#ADD8E6;"></span> Minor rivers and streams
			<span style="border-bottom: 1px solid black; display:inline-block; width:15px;"></span> Los Angeles groundwater basins
			<span style="border-bottom: 1px dashed black; display:inline-block; width:15px;"></span> County line

Figure 15. Soil type, Los Angeles Basin watershed model (LABWM), California.

**Table 6.** Table of soil parameters, model layers 1–5, Los Angeles Basin watershed model (LABWM), California.

[mm/day, millimeter per day]

<b>STATSGO map unit identifier (MUID)</b>	<b>Porosity (volume-fraction)</b>	<b>Wilting point (volume-fraction)</b>	<b>Drainage function coefficient (unitless)</b>	<b>Upper hydraulic conductivity (mm/day)</b>	<b>Lower hydraulic conductivity (mm/day)</b>
CA520	0.387	0.134	8.48	319	97
CA523	0.376	0.072	7.93	562	115
CA990	1.000	0.111	1.20	3,390	1,000
CA655	0.382	0.106	8.36	660	102
CA671	0.426	0.014	3.54	4,780	977
CA665	0.378	0.026	3.88	5,225	908
CA645	0.371	0.084	6.35	839	273
CA647	0.377	0.133	8.40	571	105
CA638	0.386	0.096	6.40	1,755	282
CA639	0.356	0.026	3.71	5,026	919
CA640	0.348	0.018	3.05	5,747	1,280
CA642	0.416	0.135	8.30	398	114
CA641	0.434	0.177	9.83	202	70
CA672	0.398	0.093	6.79	908	187
CA677	0.370	0.034	4.12	2,906	761
CA522	0.378	0.082	6.57	832	251
CA676	0.417	0.028	4.64	2,977	562
CA622	0.381	0.092	6.24	809	320



Base modified from U.S. Geological Survey and other State digital data, various scales  
 Universal Transverse Mercator, zone 11  
 North American Datum 1983



Geology modified from Jennings (1977)

EXPLANATION	
<b>Rock descriptions</b>	
<b>U</b> Undefined deposits	<b>K</b> Cretaceous—marine sedimentary rock
<b>Q</b> Quaternary—sedimentary deposits	<b>KJf</b> Jurassic—Cretaceous—marine sedimentary rock
<b>QPc</b> Quaternary—continental sedimentary deposits	<b>J</b> Triassic—Jurassic—marine sedimentary rock
<b>Qls</b> Quaternary—continental sedimentary deposits	<b>m</b> Late Tertiary—marine sedimentary rock
<b>M</b> Late Tertiary—marine sedimentary rock	<b>gr-m</b> Paleozoic—Mesozoic—mixed rock
<b>P</b> Late Tertiary—marine sedimentary rock	<b>pC</b> Precambrian—marine sedimentary rock
<b>Ep</b> Early Tertiary—marine sedimentary rock	<b>pCc</b> Precambrian—mixed rock
<b>E</b> Early Tertiary—marine sedimentary rock	<b>sch</b> Paleozoic—Mesozoic—metasedimentary rock
<b>Oc</b> Tertiary—continental sedimentary rock	<b>grMz</b> Mesozoic—plutonic rock
<b>Tv</b> Tertiary—volcanic rock	<b>gr</b> Mesozoic—plutonic rock
<b>Ti</b> Tertiary—volcanic rock	<b>grPz</b> Precambrian—Paleozoic—plutonic rock
<b>Ku</b> Cretaceous—marine sedimentary rock	<b>grpC</b> Precambrian—Paleozoic—plutonic rock
<b>Los Angeles Basin watershed model area boundary</b>	
<b>Water Replenishment District</b>	
<b>Los Angeles recharge study area</b>	
<b>Water bodies and flood-control areas</b>	
<b>Major rivers and streams</b>	
<b>Minor rivers and streams</b>	
<b>Los Angeles groundwater basins</b>	
<b>County line</b>	

Figure 16. Rock types used as input for the Los Angeles Basin watershed model (LABWM), California.

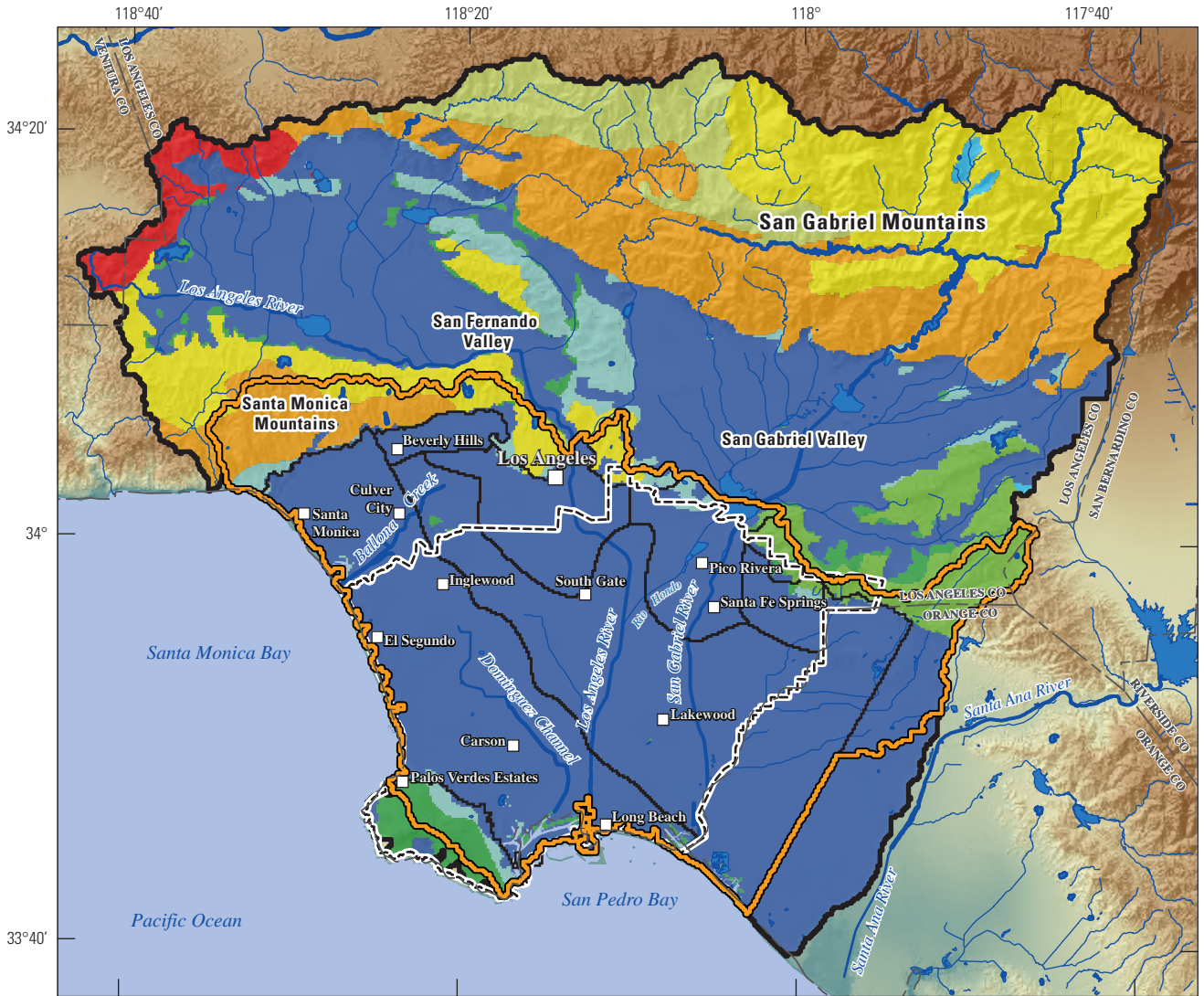
**Table 7.** Geologic parameters (layers 6–7), Los Angeles Basin watershed model (LABWM), California.

[Data source: Jennings, C.W., 1977, Geologic map of California, California Division of Mines and Geology, Geologic Data Map no. 2, scale 1:750,000

Abbreviations: HRU, hydrologic response unit; mm/day, millimeter per day; —, not applicable]

Rock descriptions	Geologic map-unit Code	Layer 6			Layer 7	
		Porosity (volume-fraction)	Upper hydraulic conductivity (mm/day)	Lower hydraulic conductivity (mm/day)	Hydraulic conductivity (mm/day)	Thickness (meters)
Unconsolidated-rock types (alluvium)						
Undefined deposits	—	0.35	2,000	100	500	0.86
Quaternary sedimentary deposits	Q	0.35	2,000	500	200	0.86
Quaternary continental sedimentary deposits	QPc	0.35	2,000	500	200	0.86
Quaternary continental sedimentary deposits	Qls	0.35	2,000	500	200	0.86
Consolidated-rock types (bedrock)						
Late Tertiary marine sedimentary rock	M	0.25	50	10	25	2.4
Late Tertiary marine sedimentary rock	P	0.25	50	10	25	2.4
Early Tertiary marine sedimentary rock	Ep	0.25	50	10	25	2.4
Early Tertiary marine sedimentary rock	E	0.25	50	10	25	2.4
Tertiary continental sedimentary rock	Oc	0.25	100	10	50	2.4
Tertiary volcanic rock	Tv	0.25	200	20	100	2.4
Tertiary volcanic rock	Ti	0.25	200	20	100	2.4
Cretaceous marine sedimentary rock	Ku	0.1	20	5	50	6
Cretaceous marine sedimentary rock	K	0.1	20	5	50	6
Jurassic–Cretaceous marine sedimentary rock	KJf	0.1	20	5	50	6
Triassic–Jurassic marine sedimentary rock	J	0.1	20	2	20	6
Late Tertiary marine sedimentary rock	m	0.1	20	2	20	6
Paleozoic–mesozoic mixed rock	gr-m	0.1	10	2	20	6
Precambrian marine sedimentary rock	pC	0.1	10	2	20	6
Precambrian mixed rock	pCc	0.1	10	1	20	6
Paleozoic - mesozoic metasedimentary rock	sch	0.1	10	1	20	6
Mesozoic plutonic rock	grMz	0.1	5	0.5	10	6
Mesozoic plutonic rock	gr	0.1	5	0.5	10	6
Precambrian–Paleozoic plutonic rock	grPz	0.1	2	0.1	10	6
Precambrian–Paleozoic plutonic rock	grpC	0.1	2	0.1	10	6





Base modified from U.S. Geological Survey and other Federal and State digital data, various scales  
 Universal Transverse Mercator, zone 11  
 North American Datum 1983



**EXPLANATION**

<b>Soil thickness, in centimeters</b>		Los Angeles Basin watershed model area boundary
0–10	>54–77	Water Replenishment District
>10–32	>77–91	Los Angeles recharge study area
>32–40	>91–105	Water bodies and flood-control areas
>40–49	>105–149	Major rivers and streams
>49–54	>149–400	Minor rivers and streams
		Los Angeles groundwater basins
		County line

**Figure 17.** Estimated soil thickness, Los Angeles Basin watershed model (LABWM), California.



The total root-zone thickness is defined by the estimated thickness of the soil zone (layers 1–5) plus the estimated thickness for layer 6. Layer-6 thickness was estimated by using a combination of the soil-thickness map and the vegetation-type map. Layer-6 thickness varied from minimum values of zero in areas of thick soils overlying unconsolidated-rock types to a maximum thickness of 4 m on the lower slope of the San Gabriel Mountains (fig. 18). For upland areas with thin soils underlain by consolidated rock types, layer-6 thickness varied from 0.001 m to 4 m, depending on soil thickness and vegetation type.

The root-zone storage capacity was calculated by using the total thickness of the root zone (soil layers and layer 6 combined), the porosity and wilting point of the soil layers, and the effective porosity of layer 6. The root-zone storage capacity is the maximum amount of water that can be stored in the root zone and available for evapotranspiration. For the LABWM area, the estimated root-zone storage capacity varied from a minimum of 200 mm to a maximum of 3,555 mm (fig. 19). For most lowland areas with thick soils, the root-zone storage capacity varied from 1,000 to 1,200 mm. For most upland areas with thinner soils underlain by consolidated rock types, the root-zone storage capacity varied from 200 to 600 mm.

## Climate Inputs

As part of the daily water-balance simulation, the LABWM calculates a unique time series of daily precipitation and maximum and minimum air temperature for each model cell. The inputs required for the spatial interpolation are daily climate records for a network of climate stations and estimates of average monthly precipitation and maximum and minimum air temperature for each climate station and for all model cells (Hevesi and others, 2003; Flint and Martin, 2012; Hevesi and Christensen, 2015). The daily climate inputs consisted of precipitation and maximum and minimum air temperature and were used with the average monthly estimates for precipitation and maximum and minimum air temperature to spatially interpolate the daily inputs for the LABWM domain by using a modified inverse-distance-squared interpolation method (Hevesi and others, 2003; Flint and Martin, 2012).

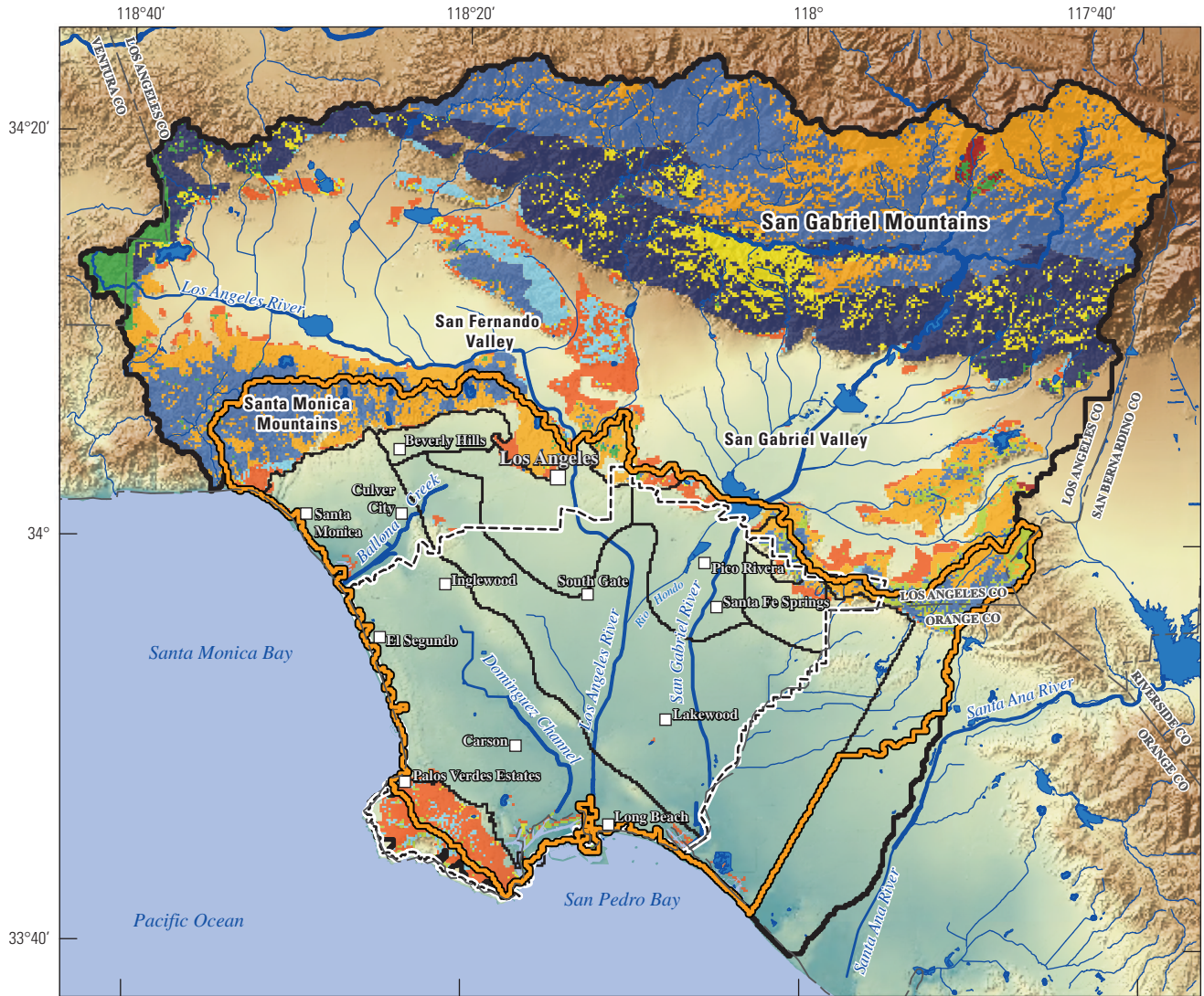
Daily climate data consisting of precipitation and maximum and minimum daily air temperature were available from a network of 201 climate stations in southern California centered in the LABWM domain (figs. 20, 21; table 2). Records from these stations are collected and stored by two different agencies: the National Climatic Data Center (NCDC) for 181 stations and the National Interagency Fire Center's Remote Automated Weather Stations (RAWS) for 20 stations. These data were used to develop the daily climate inputs for the LABWM.

Following the methods used in Flint and Martin (2012), the average monthly PRISM data (Daly and others, 1994, 2004) were used as input to the modified inverse-distance-squared interpolation. The monthly PRISM data consist of average monthly precipitation and average monthly maximum and minimum air-temperature maps available for the Nation on an approximate 800-m grid spacing for the 30-year period 1971–2000 (Daly and others, 1994, 2004). The monthly PRISM estimates incorporate multiple variables to account for complex orographic effects on precipitation, such as rain shadows and adiabatic cooling. By using inverse-distance-squared interpolation, the PRISM data were downscaled to the 201-m LABWM grid to define average monthly precipitation and maximum and minimum air-temperature estimates for all grid cells.

In addition to inputs developed for the model cells, PRISM was also used to define average monthly precipitation and average monthly maximum and minimum daily air-temperature estimates for the 201 climate stations (table 2). The average monthly precipitation and average monthly maximum and minimum daily air-temperature estimates were needed for the modified inverse-distance squared interpolation method (Flint and Martin, 2012). The nearest neighbor method was used to define the PRISM average monthly precipitation and maximum and minimum air-temperature estimates for the 201 climate stations. Figure 20 shows the average 1971–2000 January precipitation used to define estimates of January precipitation for the climate stations. Figure 21 shows the average 1971–2000 January minimum air temperature used to define January minimum air temperature for the climate stations.

In general, the LABWM interpolated average annual precipitation was similar to the PRISM estimate, but was not identical because the LABWM honored the daily climate records from the 201 climate stations, and the results were generated over a longer period (100 years) compared to the PRISM results (30 years). As with the distribution of average annual precipitation, the interpolated distribution of average air temperature was similar to the result obtained by using PRISM, but the LABWM results honored the daily air-temperature data from the climate stations.

The LABWM uses the combination of spatially distributed precipitation and average air temperature for each model cell to calculate the location and amount of precipitation falling as snow at each cell. Snowfall of 20.1 mm/yr and greater was generally limited to the higher elevations of the San Gabriel Mountains (fig. 22). Snowfall of 321 mm/yr and greater was interpolated for the highest elevations of the San Gabriel Mountains, which had a maximum snowfall of 850 mm/yr. In the Los Angeles recharge-study area (which contributes recharge to the LAGSA), snow did not fall, exception for the rare snowfall (less than 1 mm/yr) along the easternmost boundary. Average snowfall in the LABWM area was 8.3 mm/yr.



Base modified from U.S. Geological Survey and other State digital data, various scales  
 Universal Transverse Mercator, zone 11  
 North American Datum 1983

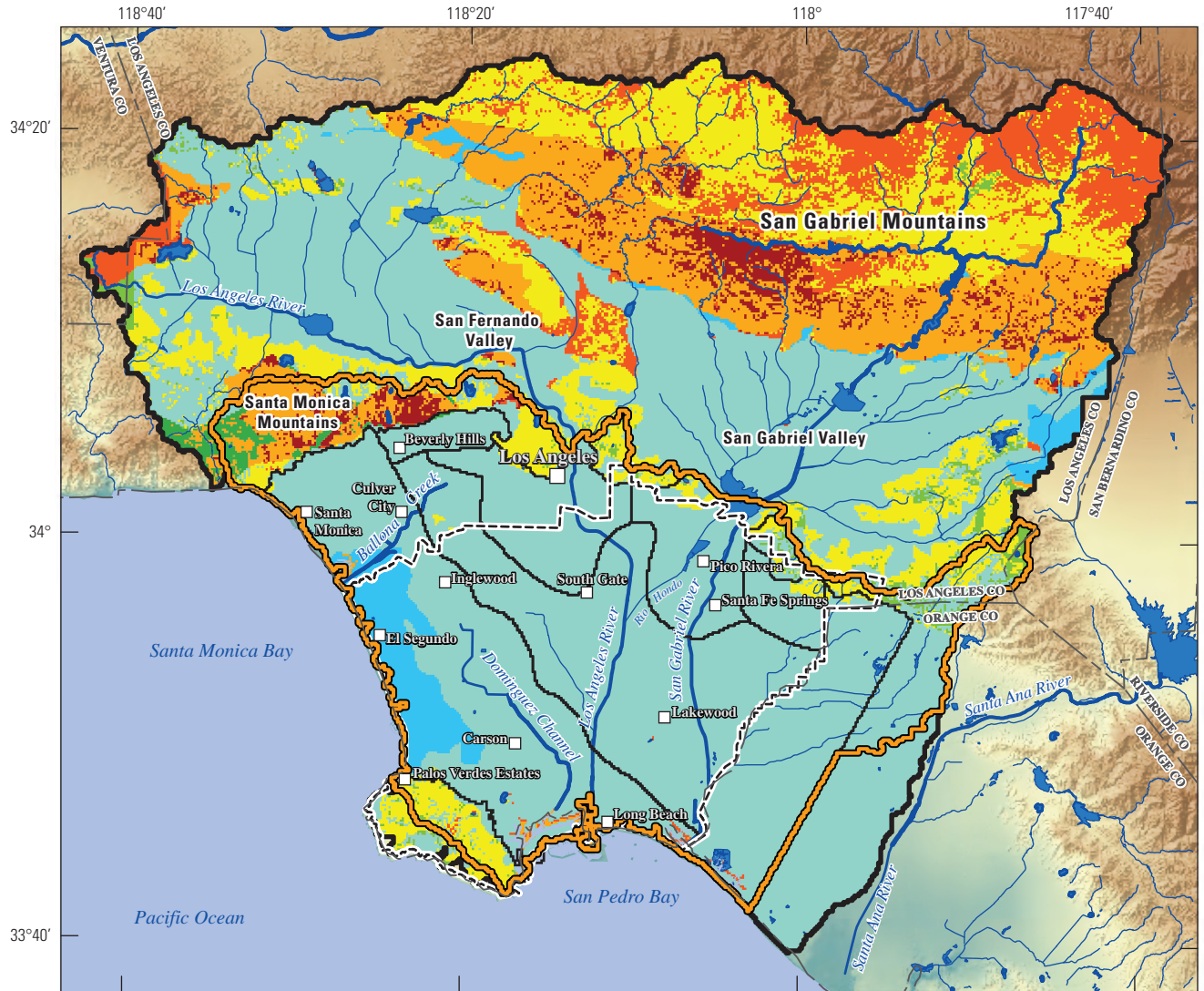


**EXPLANATION**

- |  |             |   |
|--|-------------|---|
| <b>Layer 6 thickness, in centimeters</b> |             | Los Angeles Basin watershed model area boundary |
| 0.1–80.0                                 | 241.0–280.0 | Water Replenishment District                    |
| 81.0–120.0                               | 281.0–320.0 | Los Angeles recharge study area                 |
| 121.0–160.0                              | 321.0–360.0 | Water bodies and flood-control areas            |
| 161.0–200.0                              | 361.0–400.0 | Major rivers and streams                        |
| 201.0–240.0                              |             | Minor rivers and streams                        |
|  |             | Los Angeles groundwater basins                  |
|  |             | County line                                     |

**Figure 18.** Estimated thickness of bedrock-layer 6, Los Angeles Basin watershed model (LABWM), California.





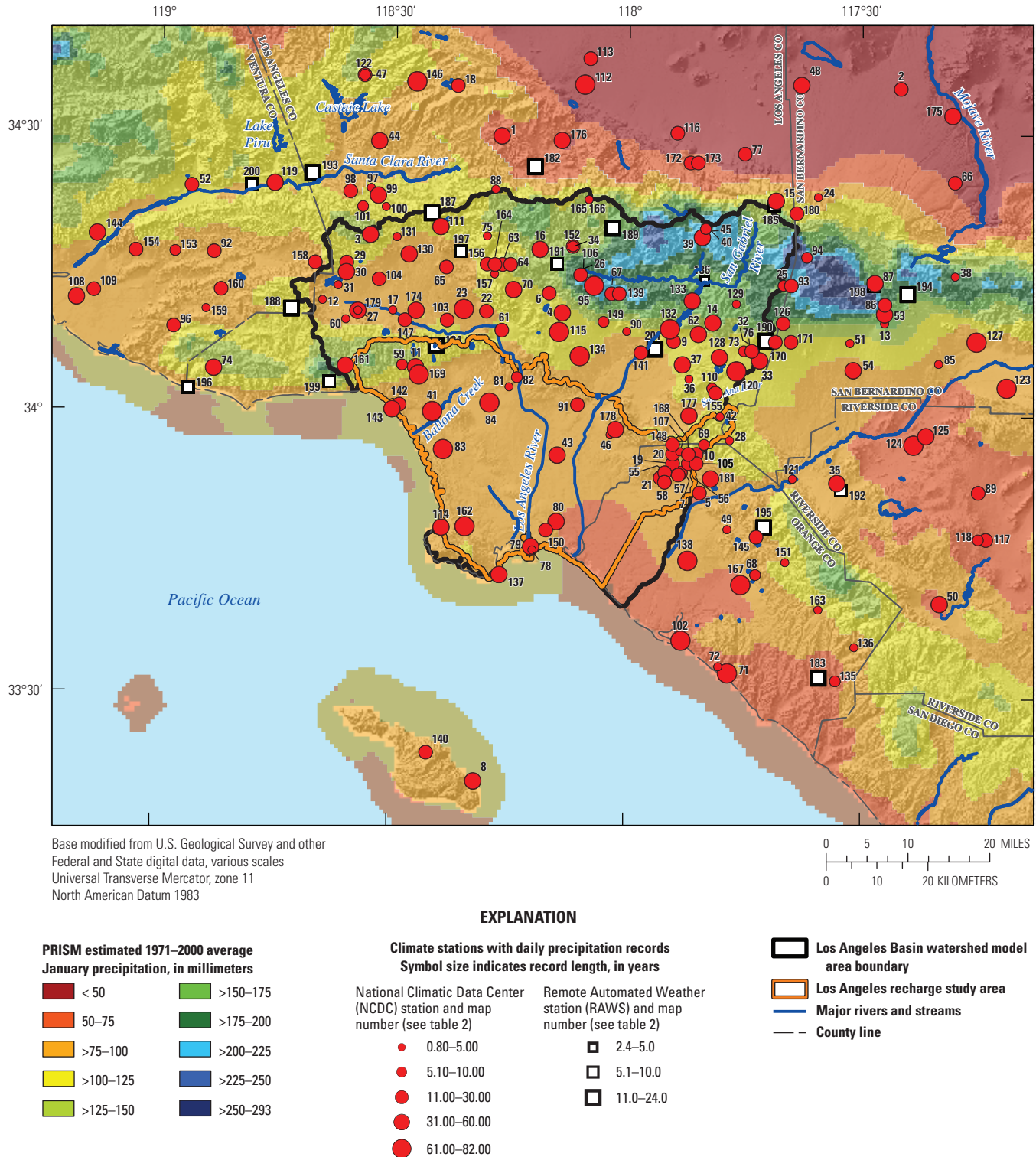
Base modified from U.S. Geological Survey and other State digital data, various scales  
 Universal Transverse Mercator, zone 11  
 North American Datum 1983



**EXPLANATION**

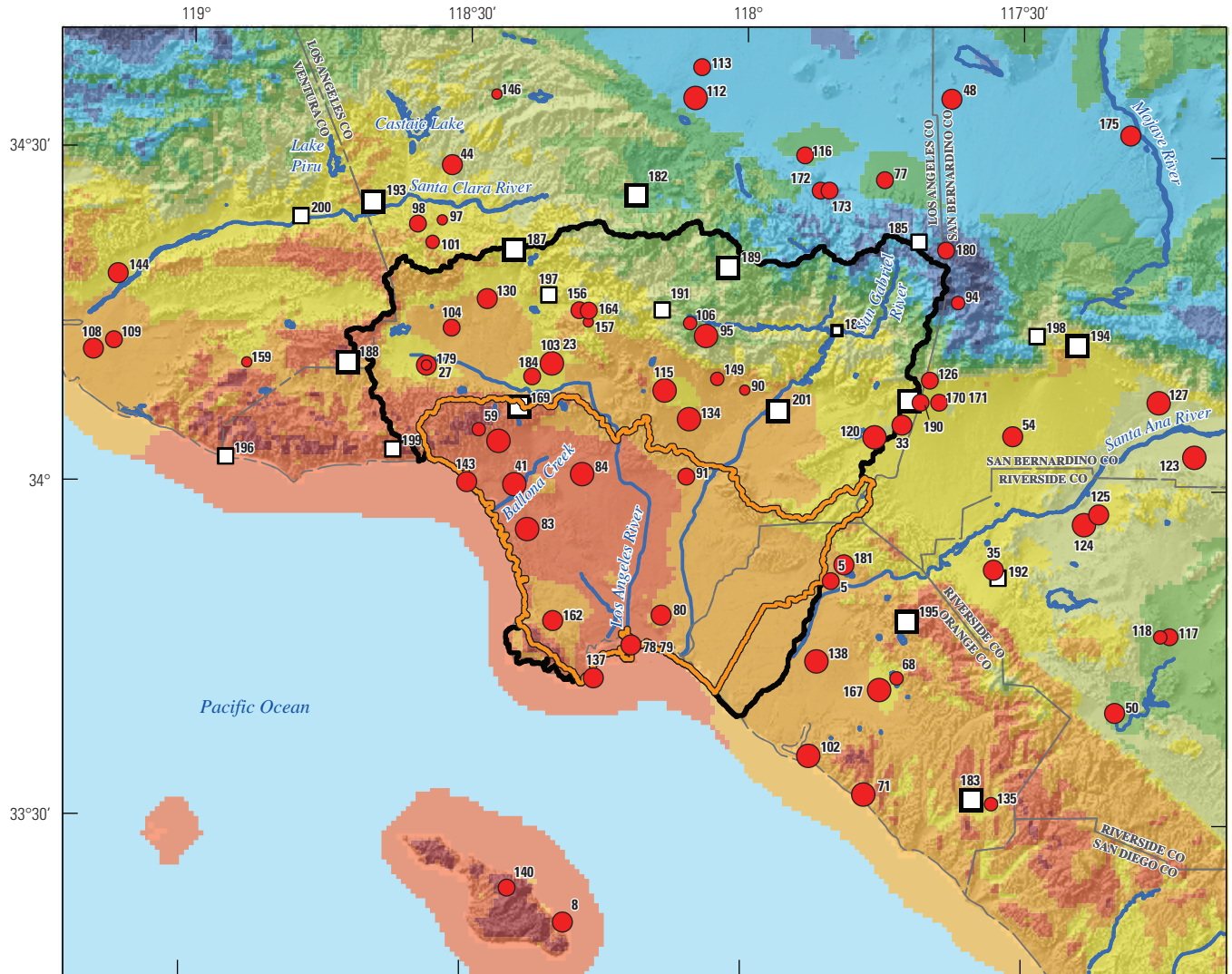
- |   |             |  |
|---|-------------|--|
| <b>Root-zone storage capacity, in millimeters</b> |             | <b>Los Angeles Basin watershed model area boundary</b> |
| 200–300   | 701–800     | <b>Water Replenishment District</b>                    |
| 301–400   | 801–1,000   | <b>Los Angeles recharge study area</b>                 |
| 401–500   | 1,001–1,200 | <b>Water bodies and flood-control areas</b>            |
| 501–600   | 1,201–1,400 | <b>Major rivers and streams</b>                        |
| 601–700   | 1,401–3,555 | <b>Minor rivers and streams</b>                        |
|   |             | <b>Los Angeles groundwater basins</b>                  |
|   |             | <b>County line</b>                                     |

**Figure 19.** Estimated root-zone storage capacity, Los Angeles Basin watershed model (LABWM), California.



**Figure 20.** Spatially distributed average January precipitation and climate stations with daily precipitation records used in the Los Angeles Basin watershed model (LABWM), California.



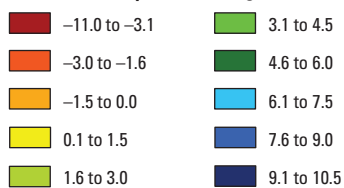


Base modified from U.S. Geological Survey and other State digital data, various scales  
 Universal Transverse Mercator, zone 11  
 North American Datum 1983

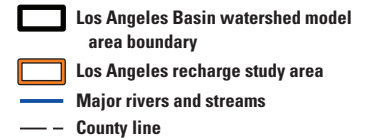
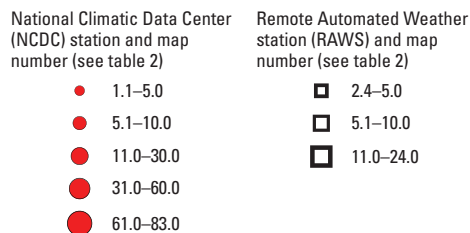


**EXPLANATION**

**PRISM estimated 1971–2000 average January minimum air temperature, in degrees Celsius**

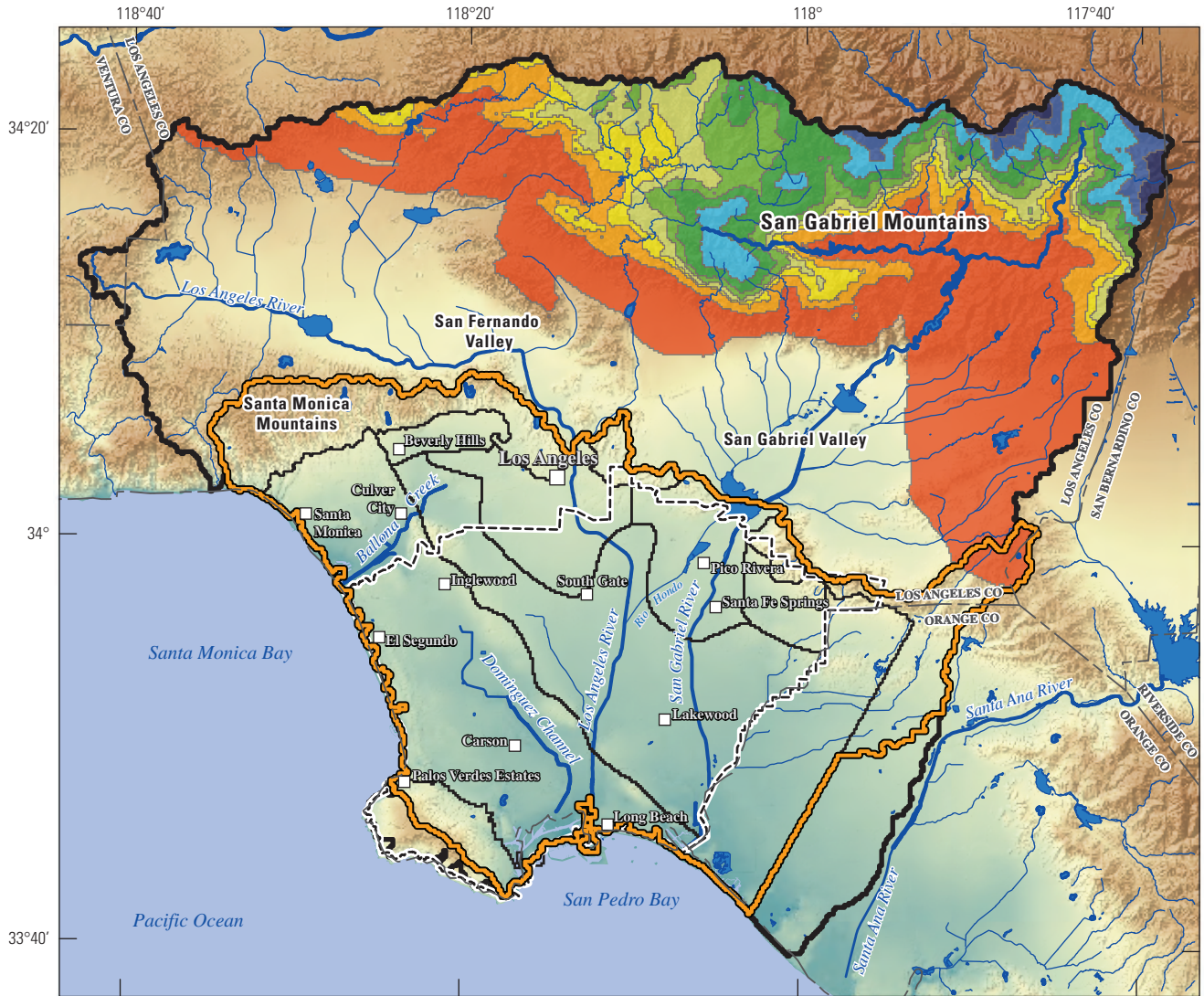


**Climate stations with daily air temperature records**  
 Symbol size indicates record length, in years



**Figure 21.** Spatially distributed average January minimum daily air temperature and climate stations with daily air-temperature records used in the Los Angeles Basin watershed model (LABWM), California.





Base modified from U.S. Geological Survey and other State digital data, various scales  
 Universal Transverse Mercator, zone 11  
 North American Datum 1983



**EXPLANATION**

- |   |               |  |
|---|---------------|--|
| <b>Los Angeles Basin watershed model interpolated 1915–2014 snowfall, in millimeters per year</b> |               | <b>Los Angeles Basin watershed model area boundary</b> |
| 0.02–1.00   | 20.10–40.00   | <b>Water Replenishment District</b>                    |
| 1.10–5.00   | 40.10–80.00   | <b>Los Angeles recharge study area</b>                 |
| 5.10–10.00  | 80.10–160.00  | <b>Water bodies and flood-control areas</b>            |
| 10.10–20.00   | 160.10–320.00 | <b>Major rivers and streams</b>                        |
| 320.10–850.00   |               | <b>Minor rivers and streams</b>                        |
|   |               | <b>Los Angeles groundwater basins</b>                  |
|   |               | <b>County line</b>                                     |

**Figure 22.** Average snowfall estimated for water years 1915–2014 by using the Los Angeles Basin watershed model (LABWM), California.

## Atmospheric Parameters

Monthly atmospheric parameters are used by the LABWM to simulate solar radiation on an hourly basis. The simulated solar radiation is then used to simulate daily PET on the basis of an energy-balance calculation that also incorporates the daily air-temperature inputs. The atmospheric parameters used for the LABWM were based on the values used in the previous INFILv3 applications in the southern California region (Nishikawa and others, 2004; Rewis and others, 2006; Flint and Martin, 2012). The monthly atmospheric parameters are shown in table 8 and included (1) ozone-layer thickness (ozone), (2) precipitable water in the atmosphere (WP), (3) mean atmospheric turbidity (beta), and (4) circumsolar radiation (CSR). Monthly ozone varied from 0.27 to 0.33, WP varied from 1.0 to 2.44, beta varied from 0.075 to 0.09, and CSR varies from 0.57 to 0.9 (table 8).

## Model Coefficients

Model coefficients are used in the INFILv3 code for empirical functions and controls that are applied on a basin-wide scale (rather than on a grid-cell basis). The empirical functions include (1) storm durations for winter and summer storms, (2) sublimation and snowmelt, and (3) effective hydraulic conductivities for stream channels (Hevesi and others, 2003; U.S. Geological Survey, 2008). For the LABWM area, the duration of winter storms (September 1 to May 31) was estimated to be 12 hours, and the duration of summer storms (June 1 to August 31) was estimated to be 2 hours. These estimated storm durations were used in previous INFILv3 applications for nearby study areas: the San Geronio Pass area east of the LABWM area (Rewis and others, 2006), the Big Bear Valley study area (Flint and Martin, 2012), and the San Geronio Pass region (Hevesi and Christensen, 2015).

Values for model coefficients used for simulating snowmelt and sublimation were also the same as those used in previous INFILv3 applications in the southern California region (Hevesi and others, 2003; Nishikawa and others, 2004; Rewis and others, 2006; Flint and Martin, 2012; Hevesi and Christensen, 2015). Precipitation was assumed to be in the form of snow when the average daily air temperature was equal to or less than 32°F. Daily snowfall was added to the snowpack-storage term in the daily water balance. When the average daily air temperature was less than or equal to freezing, snowmelt was assumed to be zero, but the snowpack-storage term was still reduced a fraction by using an assumed sublimation model that calculated sublimation as a percentage of PET and the available water in the snowpack. When the daily maximum air temperature was greater than freezing, an empirical temperature-index model was applied by using parameters calibrated for the Sierra Nevada (Maidment, 1993) to calculate the daily snowmelt, and the snowpack was reduced by this amount.

Model coefficients used for simulating the effective hydraulic conductivities for stream channels were dependent on the number of upstream cells and were adjusted during the model-calibration process. Model coefficients used to represent stream-channel characteristics included (1) the minimum number of upstream cells used to define the main stream channels and (2) the saturated hydraulic-conductivity multiplier for soils in the main stream channels. For the LABWM, the minimum number of upstream cells was set to 100, and the saturated hydraulic-conductivity multiplier was set 10. This configuration assumed coarser soils in larger channels and a tenfold increase in the saturated hydraulic conductivity of the channel bed relative to the surrounding inter-channel areas.

## Boundary Conditions

Boundary conditions for the LABWM included the simulated daily surface-water discharge from model subdomains that were tributaries to downstream subdomains (fig. 9). To establish the boundary conditions, the upstream model subdomains were simulated first. The simulated surface-water discharges from an upstream model subdomain were input to the downstream model subdomain as daily inflows to the grid cell directly downstream from the outflow cell in the upstream subdomain. In the LABWM layout, the Rio Hondo (RIOH) and upper Los Angeles River (ULAR) subdomains were upstream from the lower Los Angeles River (LARV) subdomain, and the upper San Gabriel River (USGR) subdomain was upstream from the lower San Gabriel River (SGRV) subdomain. To define the surface-water inflow boundary conditions for the lower Los Angeles River (LARV) and SGRV subdomains, the Rio Hondo (RIOH), upper Los Angeles River (ULAR), and upper San Gabriel River (USGR) subdomains were simulated first.

Boundary conditions also included estimates of average quarterly urban irrigation for the general area of the Los Angeles recharge-study area. The average quarterly rates were applied uniformly to each quarterly period in the simulation period. The quarterly urban-irrigation estimates were specified for all irrigated cells as a constant daily inflow boundary condition for each quarter. Annual irrigation was calculated from the quarterly urban irrigation estimates. The annual irrigation result indicated the spatial distribution of the quarterly irrigation estimates included in the model (fig. 23). Although the amount of urban irrigation was different for each quarter, the spatial distribution of urban irrigation was constant. The high annual irrigation rates of 321 to 412 mm/yr were estimated for residential areas that had a relatively large percentage of pervious area. Annual irrigation rates of 241 to 280 mm/yr were more widespread and were estimated for the higher density residential areas that had a smaller percentage of pervious area. Relatively low irrigation rates of 40 to 160 mm/yr were estimated for the more densely developed commercialized zones and transportation corridors.

**Table 8.** Atmospheric parameters, Los Angeles basin watershed model, California.

[Beta, average monthly mean atmospheric turbidity; cm, centimeter; CSR, average monthly circumsolar radiation; Ozone, average monthly ozone layer thickness; WP, average monthly precipitable water in the atmosphere]

Month	Monthly atmospheric parameter values <sup>1</sup>			
	Ozone (cm)	WP (cm)	Beta (unitless)	CSR (unitless)
January	0.29	1.00	0.075	0.85
February	0.31	1.00	0.075	0.85
March	0.32	1.05	0.075	0.85
April	0.33	1.10	0.085	0.85
May	0.33	1.50	0.085	0.74
June	0.32	1.80	0.090	0.74
July	0.30	2.20	0.090	0.57
August	0.29	2.44	0.084	0.57
September	0.28	2.00	0.077	0.66
October	0.27	1.40	0.075	0.74
November	0.27	1.05	0.075	0.90
December	0.28	0.95	0.075	0.90

<sup>1</sup> Parameter values from U.S. Geological Survey, 2008.

The lowest irrigation rates, less than 40 mm, were estimated for the high-density developed zones, such as major highways and city centers. Irrigation rates of zero were estimated for industrialized areas.

Average quarterly (January–March, April–June, July–September, October–December) urban irrigation, calculated as the basin-wide average irrigation depth for the 11 subdomains with urban irrigation, indicated variability in the estimated irrigation among quarters and subdomains (fig. 24). The Topanga Creek (TOPC) subdomain did not have any cells with urban irrigation and, therefore, was omitted. The January–March quarter had the smallest estimated irrigation amounts, with basin-wide average irrigation of 5–10 mm for 9 of the 11 subdomains. The July–September quarter had the largest estimated irrigation amounts, with average basin-wide irrigation of 53–64 mm for seven of the subdomains. For all quarters, the lower Santa Monica Basin (LSMB) subdomain had the most irrigation, and the Seal Beach (SEAL) subdomain had the second most irrigation. The upper Los Angeles River (ULAR) subdomain had the smallest irrigation amount because only a small part of the subdomain was included in the area where urban-irrigation estimates were defined.

## Initial Conditions

Initial conditions required by LABWM include the water contents of all root-zone layers, the perched zone (layer 7), and the snowpack. As in previous INFILv3 applications

(Nishikawa and others, 2004; Rewis and others, 2006; Flint and Martin, 2012; Hevesi and Christensen, 2015), all simulations in this study were run by using an initial water content for root-zone layers 1–5 (soil layers) that was calculated as 1.5 times the wilting-point water content (table 6). An initial water content of zero was assigned to root-zone layer 6, the perched zone (layer 7), and the snowpack. An initialization period of 9.75 years (from January 1, 1905, to September 30, 1914) was used for all simulations in order to mitigate the effect of initial conditions on the 100-year target-simulation period (water years 1915–2014).

## Model Calibration

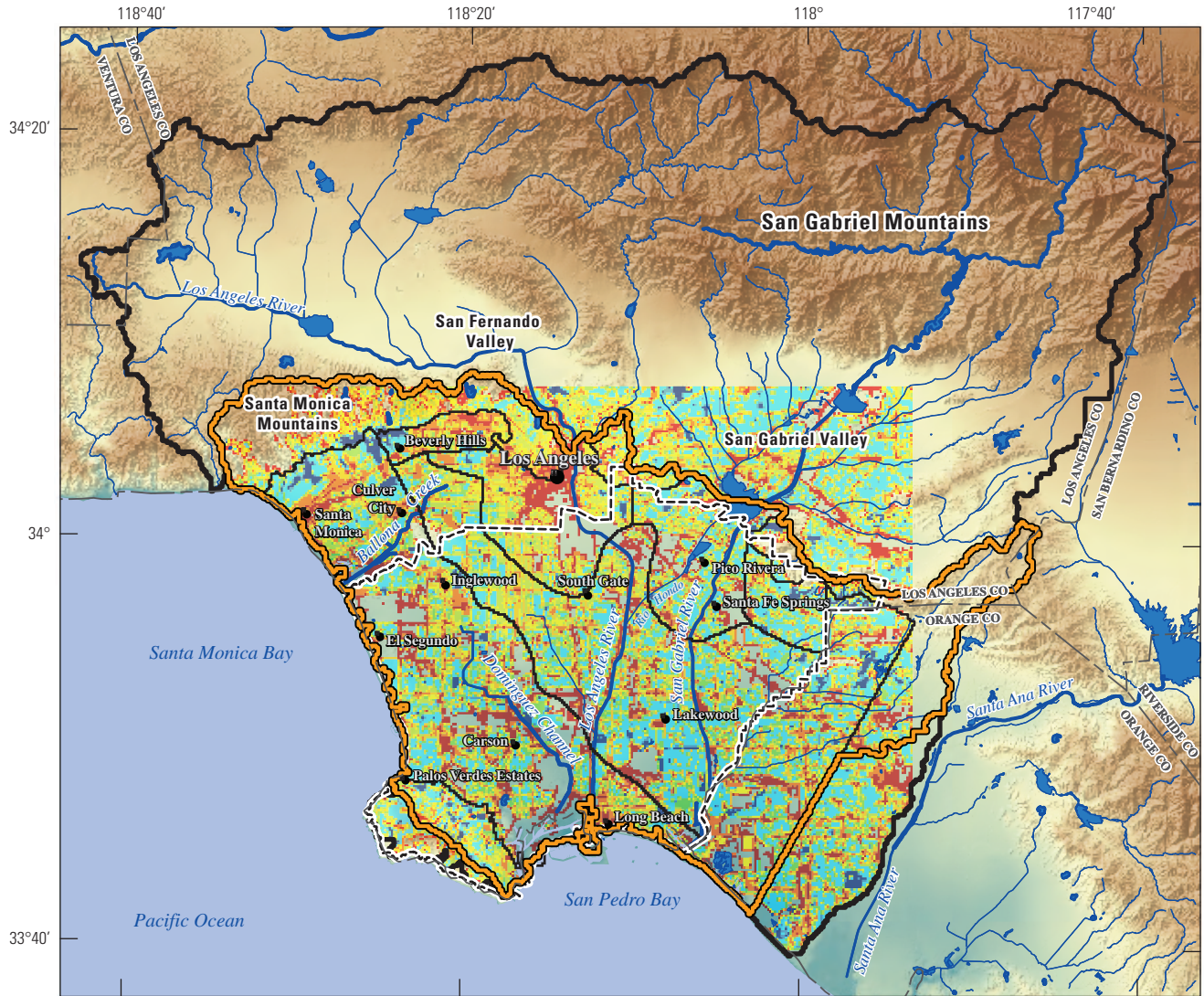
Model calibration is the process of making adjustments, within justifiable ranges, to initial estimates of selected model parameters to obtain reasonable agreement between simulated and measured observations. Precipitation-runoff models, such as PRMS (Markstrom and others, 2008; Jeton and Maurer, 2011) and INFILv3 (Hevesi and others, 2003; Rewis and others, 2006) typically are calibrated by comparing simulated streamflow to available records of measured streamflow, preferably by using continuous records that span multi-year periods. In this study, calibration of the LABWM consisted of comparing simulated daily, monthly, and annual streamflow with measured streamflow at six gages in the LABWM area.

## Streamflow Observations

The streamflow records used for calibration included observations at four USGS streamflow gaging stations (<http://waterdata.usgs.gov/ca/nwis>) and two streamflow gaging stations maintained by the Los Angeles County Department of Public Works (Los Angeles County Department of Public Works, 2006; <http://dpw.lacounty.gov/wrd/Runoff/index.cfm>; fig. 25; table 9). Three gages, BALC6, COMP4, and COYC1, have drainage areas in the Los Angeles recharge-study area (area defined as contributing recharge to the LAGSA), and three gages, TOPG1, ALHW6, and SJCE1, have drainage areas outside of, but next to the Los Angeles recharge-study area (area contributing recharge to the LAGSA) boundary (fig. 25). The four USGS gages had daily mean discharge records. The LACDPW gages had a combination of daily, monthly, and annual (water year) records. In general, the USGS records were older, with the most recent data for water year 1979, whereas the LACDPW records were more recent. The LACDPW gages were still active at the time of this study. The record lengths ranged from a minimum of 14 years for gage SJCE1 to a maximum of 62 years for gage ALHW6.

The drainage areas for the six gages vary from a minimum of 47 km<sup>2</sup> for TOPG1 to a maximum of 388 km<sup>2</sup> for COYC1. Only one gage, COMP4, has a drainage area completely within the LAGSA. Two gages, BALC6 and COYC1, have drainage areas mostly within the LAGSA.





Base modified from U.S. Geological Survey and other State digital data, various scales  
 Universal Transverse Mercator, zone 11  
 North American Datum 1983



**EXPLANATION**

<b>Los Angeles Basin watershed model estimated 1915–2014 urban irrigation, in millimeters per year</b>		Los Angeles Basin watershed model area boundary
0.1–40	161–200	Water Replenishment District
41–80	201–240	Los Angeles recharge study area
81–120	241–280	Water bodies and flood-control areas
121–160	281–320	Major rivers and streams
321–412		Minor rivers and streams
		Los Angeles groundwater basins
		County line

**Figure 23.** Average annual estimated urban irrigation, Los Angeles Basin watershed model (LABWM), California.



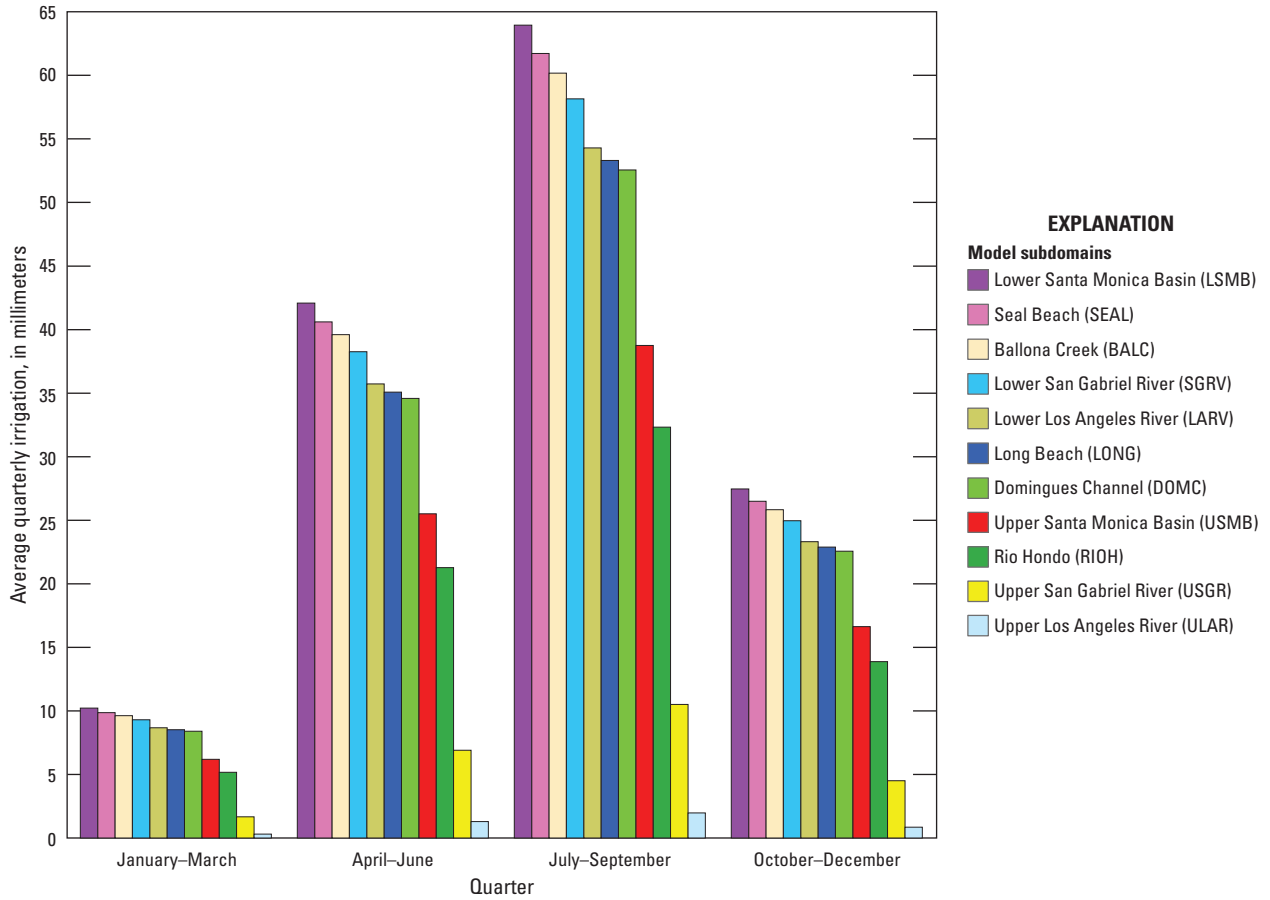
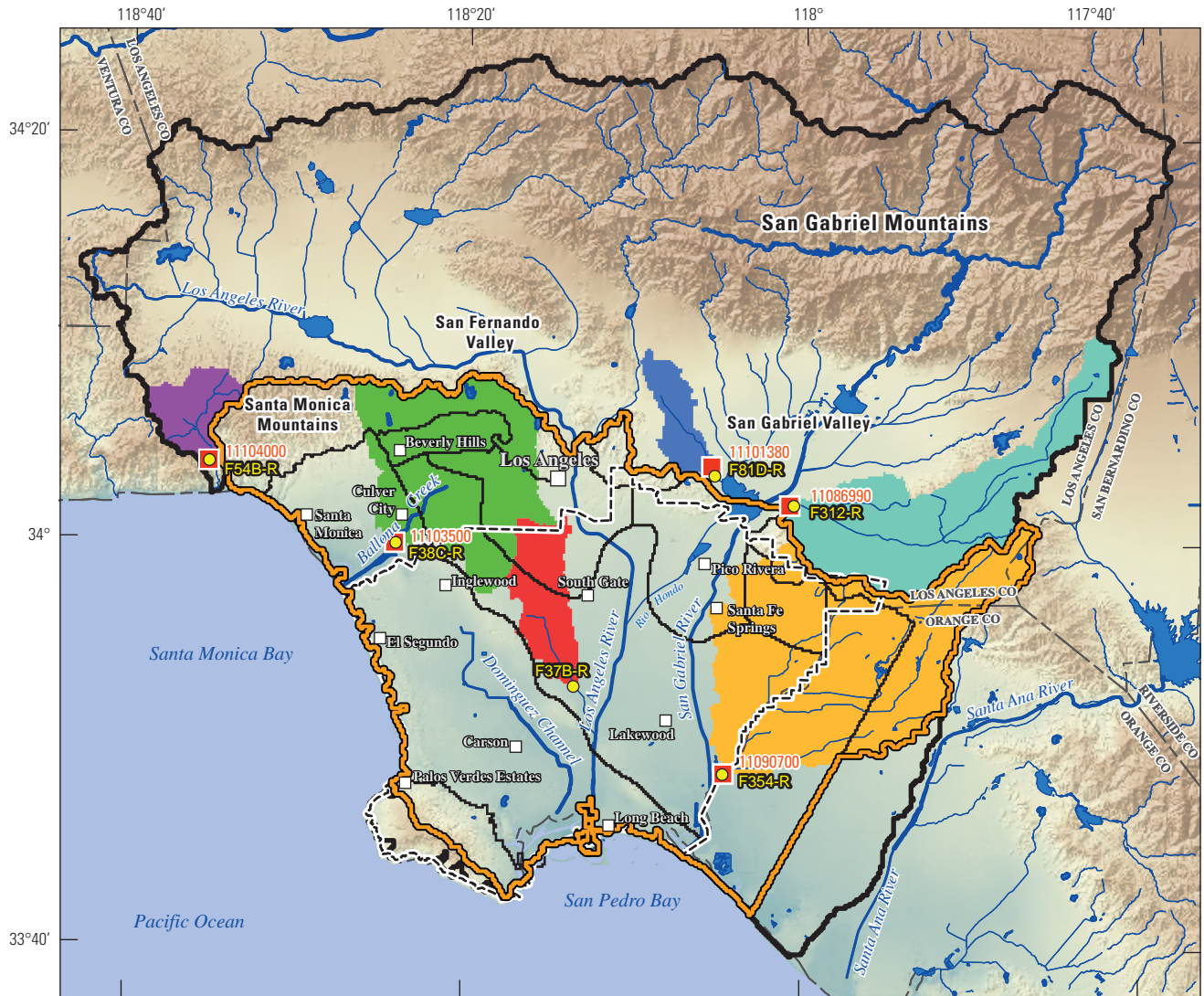


Figure 24. Average quarterly irrigation for 11 subdomains, Los Angeles Basin watershed model (LABWM), California.



Base modified from U.S. Geological Survey and other State digital data, various scales  
 Universal Transverse Mercator, zone 11  
 North American Datum 1983



**EXPLANATION**

- |  |                 |  |
|--|-----------------|--|
| <b>Calibration watersheds and corresponding gage codes</b> |                 | <b>Los Angeles Basin watershed model area boundary</b> |
| ALHW6  | COMP4           | <b>Water Replenishment District</b>                    |
| TOPG1  | COYC1           | <b>Los Angeles recharge study area</b>                 |
| BALC6  | SJCE1           | <b>Water bodies and flood-control areas</b>            |
|  |                 | <b>Major rivers and streams</b>                        |
|  |                 | <b>Minor rivers and streams</b>                        |
|  |                 | <b>Los Angeles groundwater basins</b>                  |
|  |                 | <b>County line</b>                                     |
|  | <b>F354-R</b>   | <b>LACDPW gages</b>                                    |
|  | <b>11090700</b> | <b>USGS gages</b>                                      |

**Figure 25.** Six streamflow-gaging stations used for model calibration, Los Angeles Basin watershed model (LABWM), California.

**Table 9.** Streamflow-gaging stations and streamflow records used for model calibration, Los Angeles Basin watershed model (LABWM), California.

[DMS, degree minute second; ID, identifier; km<sup>2</sup>, square kilometer; LACDPW, Los Angeles County Department of Public Works; mm/dd/yyyy, month/day/year; NA, not applicable; USGS, U.S. Geological Survey; —, not applicable]

Streamflow gage code	Streamflow gage name	USGS streamflow gage ID	LACDPW streamflow gage ID	Streamflow data sources	Drainage area (km <sup>2</sup> )	Streamflow gage location		Streamflow record		
						Latitude (DMS)	Longitude (DMS)	Start date (mm/dd/yyyy)	End date (mm/dd/yyyy)	Years of record
COMP4	COMPTON CREEK NEAR GREENLEAF DRIVE	—	F37B-R	LACDPW	59	33°52'54"	-118°13'30"	10/01/1996	09/30/2011	15
BALC6	BALLONA C NR CULVER CITY CA	11103500	F38C-R	USGS LACDPW	232	33°59'54"	-118°24'05"	03/01/1928	09/30/1978	51
COYC1	COYOTE CA LOS ALAMITOS CA	11090700	F354-R	USGS LACDPW	388	33°48'38"	-118°04'28"	10/01/1963	09/30/1979	16
TOPG1	TOPANGA C NR TOPANGA BCH CA	11104000	F54B-R	USGS LACDPW	47	34°03'52"	-118°35'10"	01/01/1930	09/30/1979	49
ALHW6	ALHAMBRA WASH NEAR KLINGERMAN STREET	—	F81D-R	LACDPW	39	34°03'22"	-118°05'10"	10/01/1931	09/30/2011	62
SJCE1	SAN JOSE C NR EL MONTE CA	11086990	F312-R	USGS	227	34°01'55"	-118°00'40"	10/01/1964	09/30/1978	14

Streamflow records for gages COMP4, TOPG1, and ALHW6 were generally not affected by flow diversions. Records from three gages (SJCE1, BALC6, and COYC1) were partially affected by flow regulations from reservoirs, detention basins, debris basins, or spreading grounds upstream from the gages. Although the regulated flows increased uncertainty in model calibration, including these records was preferable to not including the records because of the general sparsity of streamflow records for the study area.

## Calibration Procedure

Calibration of the model was done by using a trial and error approach where selected model parameters were adjusted until a satisfactory fit was obtained between simulated and measured streamflow values. Parameters adjusted during the calibration process were based on findings from previous applications of the INFILv3 code (Hevesi and others, 2003; Rewis and others, 2006; Flint and Martin, 2012; Hevesi and Christensen, 2015). The parameters included root-zone layer thicknesses, root-density coefficients, soil hydraulic conductivity, upper and lower hydraulic conductivity for layer 6, the effective porosity of layer 6, the lateral seepage hydraulic conductivity for layer 7, and coefficients defining stream channel characteristics.

A qualitative and quantitative analysis of the goodness-of-fit between the simulated and measured streamflow discharge was done by using daily mean discharge, monthly mean discharge, and annual (water year) mean discharge. Daily streamflow was used to analyze the match of simulated streamflow to peak flows and the timing of runoff in response to storms. Monthly streamflow was used to analyze model fit in terms of matching seasonal variations in streamflow. Annual streamflow was used to evaluate model fit in terms of overall bias and the match to variations in streamflow for wet and dry periods.

The qualitative analysis consisted of visual comparisons of the closeness-of-fit between measured and simulated streamflow hydrographs. A qualitative analysis of monthly and annual streamflow was also done by using a visual comparison of the closeness-of-fit between the plotted values of measured and simulated streamflow (for monthly and annual flows) and the one-to-one line for measured streamflow.

The quantitative analysis was based on two goodness-of-fit statistics: (1) the percent average estimation error (PAEE; Rewis and others, 2006; Woolfenden and Nishikawa, 2014) and (2) the Nash-Sutcliffe model efficiency (NSME; Nash and Sutcliffe, 1970; Markstrom and others, 2008). The PAEE provides a measure of model bias and was calculated as described in Woolfenden and Nishikawa (2014). For this study, absolute PAEE values of 20 to 10.1 percent were considered satisfactory, absolute values of 10 to 5.1 percent were considered good, and values between plus 5 and minus 5 percent were considered very good. In general, values of 20 and less indicated an acceptable or favorable model calibration, whereas values greater than 20 indicated a poor calibration.

The NSME provides a standardized measure of the overall goodness-of-fit in terms of the mean-squared estimation error (Markstrom and others, 2008) and was calculated following Nash and Sutcliffe (1970). Values of NSME greater than 0 indicate a model fit better than the sample mean, and values close to 1.0 indicate a good match between simulated and measured streamflow (Nash and Sutcliffe, 1970; Markstrom and others, 2008). For this study, NSME values of 0.6 to 0.69 were considered satisfactory, values of 0.7 to 0.79 were considered good, values of 0.8 to 0.89 were considered very good, and values of 0.9 or greater were considered excellent in terms of indicating model performance. In general, values of 0.6 and greater indicated an acceptable or favorable model calibration, whereas values less than 0.6 indicated a poor calibration.

## Calibration Results

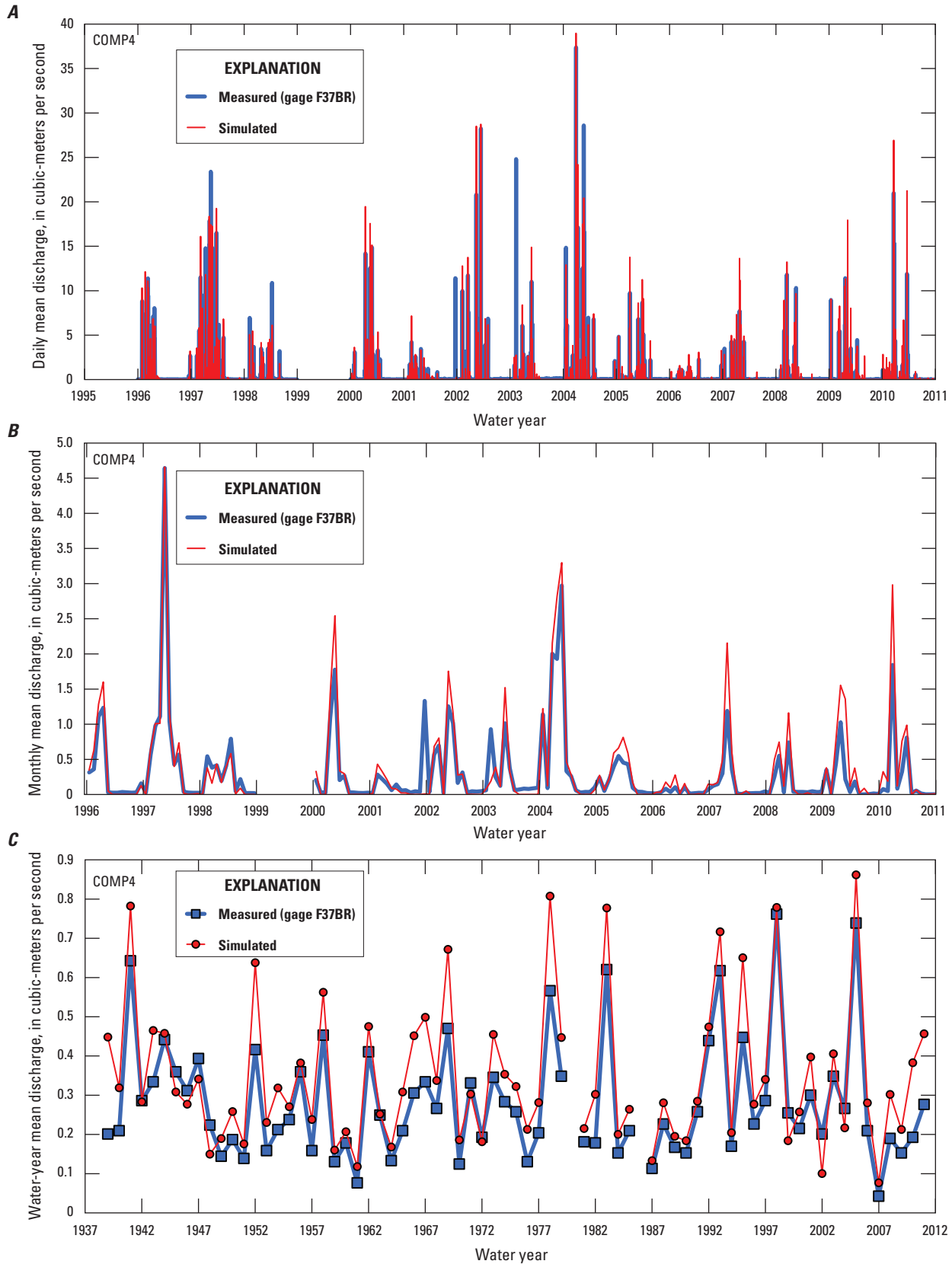
### Compton Creek (gage COMP4)

Comparison of hydrographs for gage COMP4 on Compton Creek indicated a good to very good match between simulated and measured daily and monthly streamflow; however, a poor fit was indicated between simulated and measured annual streamflow by the NSME statistic (fig. 26; table 10). The model indicated a tendency to overestimate flows at gage COMP4, resulting in a PAEE of 18 for daily and monthly flows and 23 for the longer, annual hydrograph. For the shorter period covered by the daily and monthly records, a generally favorable match was indicated between simulated and measured peak flows. The annual records cover a longer period (water years 1939–2011), however, and the annual hydrograph comparison indicated a tendency of the model to overestimate total streamflow for the water years when there was higher total streamflow, particularly during the early part of the record (fig. 26C).

### Ballona Creek (gage BALC6)

Comparison of hydrographs for gage BALC6 on Ballona Creek indicated a generally favorable match between simulated and measured streamflow for water years 1932–78 (fig. 27; table 10). The results for Ballona Creek indicated an overall better calibration compared to gage COMP4, because estimation bias was much closer to zero; a PAEE value of –6 indicated a good calibration for daily, monthly, and annual flows. In addition, the NSME results were better for monthly and annual flows compared to results for gage COMP4; an excellent result of 0.93 was obtained for monthly flows, and a very good result of 0.82 was obtained for annual flows. A good general match to the peak monthly and annual flow was a primary reason for the greater NSME values. Although the peak daily flows were not as well matched by the model, the intermediate-to-low daily flows were well matched, and the NSME of 0.74 indicated a good calibration result.



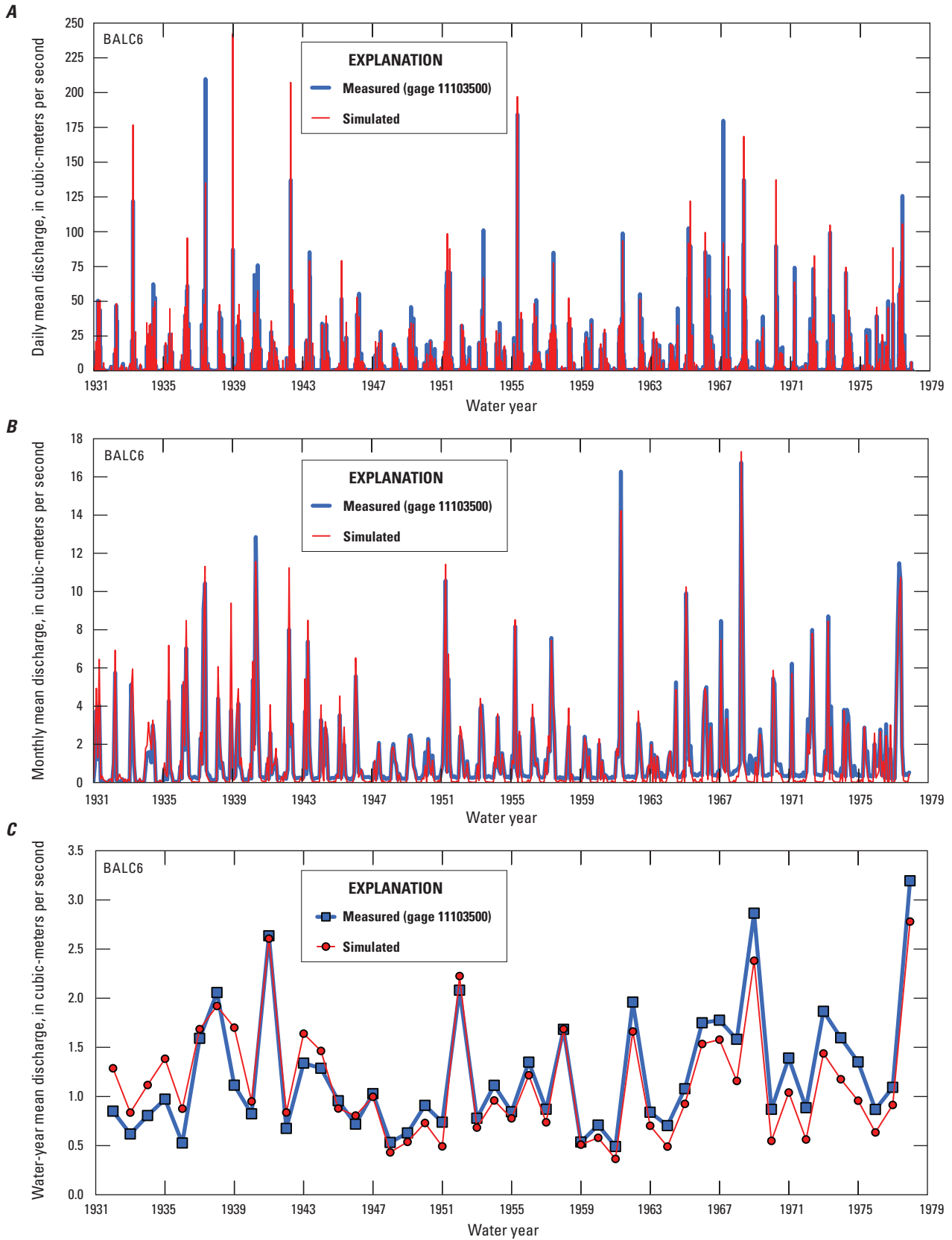


**Figure 26.** Comparison of simulated and measured streamflow at gage COMP4, Los Angeles Basin watershed model (LABWM), California: A, daily; B, monthly; C, annually.

**Table 10.** Summary of model calibration results, Los Angeles Basin watershed model (LABWM), California.

[cms, cubic meters per second; ID, identifier; LACDPW, Los Angeles County Department of Public Works; mm/dd/yyyy; month/day/year; NMSE, Nash-Sutcliffe model efficiency; PAEE, percent average estimation error; USGS, U.S. Geological Survey]

Gage code	Gage name	Data source and gage identification code	Simulated streamflow			Calibration statistics			
			Average (cms)	Maximum (cms)	Minimum (cms)	PAEE	Goodness of fit	NSME	Goodness of fit
COMP4	COMPTON CREEK NEAR GREENLEAF DRIVE	LACDPW F37B-R	0.36	39.0	0.000	18	Satisfactory	0.76	Good
COMP4	COMPTON CREEK NEAR GREENLEAF DRIVE	LACDPW F37B-R	0.36	4.7	0.000	18	Satisfactory	0.81	Very Good
COMP4	COMPTON CREEK NEAR GREENLEAF DRIVE	LACDPW F37B-R	0.35	0.9	0.077	23	Poor	0.57	Poor
BALC6	BALLONA C NR CULVER CITY CA	USGS 11103500	1.14	242.5	0.002	-6	Good	0.74	Good
BALC6	BALLONA C NR CULVER CITY CA	USGS 11103500	1.15	17.3	0.002	-6	Good	0.93	Excellent
BALC6	BALLONA C NR CULVER CITY CA	USGS 11103500	1.14	2.8	0.365	-6	Good	0.82	Very Good
COYC1	COYOTE C A LOS ALAMITOS CA	USGS 11090700	1.39	148.4	0.000	11	Satisfactory	0.77	Good
COYC1	COYOTE C A LOS ALAMITOS CA	USGS 11090700	1.39	15.8	0.000	10	Good	0.87	Very Good
COYC1	COYOTE C A LOS ALAMITOS CA	USGS 11090700	1.38	3.1	0.654	11	Satisfactory	0.83	Very Good
TOPG1	TOPANGA C NR TOPANGA BCH CA	USGS 11104000	0.18	81.0	0.000	4	Very Good	0.35	Poor
TOPG1	TOPANGA C NR TOPANGA BCH CA	USGS 11104000	0.18	5.3	0.000	3	Very Good	0.68	Satisfactory
TOPG1	TOPANGA C NR TOPANGA BCH CA	USGS 11104000	0.18	0.6	0.004	4	Very Good	0.73	Good
ALHW6	ALHAMBRA WASH NEAR KLINGERMAN STREET	LACDPW F81D-R	0.19	31.4	0.000	-18	Satisfactory	0.78	Good
ALHW6	ALHAMBRA WASH NEAR KLINGERMAN STREET	LACDPW F81D-R	0.19	2.7	0.000	-18	Satisfactory	0.94	Excellent
ALHW6	ALHAMBRA WASH NEAR KLINGERMAN STREET	LACDPW F81D-R	0.19	0.5	0.043	-14	Satisfactory	0.52	Poor
SJCE1	SAN JOSE C NR EL MONTE CA	USGS 11086990	0.77	109.2	0.001	-16	Satisfactory	0.74	Good
SJCE1	SAN JOSE C NR EL MONTE CA	USGS 11086990	0.78	9.6	0.002	-16	Satisfactory	0.91	Excellent
SJCE1	SAN JOSE C NR EL MONTE CA	USGS 11086990	0.80	1.8	0.343	-15	Satisfactory	0.79	Good



**Figure 27.** Comparison of simulated and measured streamflow at gage BALC6, Los Angeles Basin watershed model (LABWM), California: A, daily; B, monthly; C, annually.

## Coyote Creek (gage COYC1)

Calibration results for gage COYC1 on Coyote Creek were considered good for daily streamflow and very good for monthly and annual streamflow in terms of the NSME statistic (fig. 28; table 10). The PAEE result indicated a tendency of the model to overestimate streamflow at this gage, but only by about 10 to 11 percent, which was considered a good to satisfactory calibration for this study. The daily, monthly, and annual hydrographs all indicated a shift in estimation bias through time from water year 1964 to water year 1979. Prior to about water year 1971, the model showed a tendency to overestimate the peak daily flows, the peak monthly flows, and the annual flows. After water year 1977, the model showed a tendency to underestimate the peak daily flows, the peak monthly flows, and the annual flows. For the central part of the simulation period, a better overall fit between simulation and measured flow was indicated.

## Toponga Creek (gage TOPG1)

Results for NSME for gage TOPG1 on Toponga Creek ranged from poor for daily streamflow to satisfactory for monthly streamflow and good for annual streamflow (fig. 29; table 10). Although the PAEE result is less than 5, and therefore indicated a very good calibration in terms of minimized estimation bias, the model also indicated a tendency to overestimate many of the lower flows and underestimate many of the higher flows, causing a deterioration in the NSME statistic. This was especially true for daily streamflow, and the over- and underestimation of peak flows resulted in a poor NSME of 0.35. The peak monthly and annual flows were better matched by the model, improving the NSME to 0.68 for monthly streamflow and to 0.73 for annual streamflow. Unlike results for gages BALC6 and COYC1, the hydrographs for gage TOPG1 did not indicate a shift in the fit between simulated and measured streamflow through time. It is possible that the changes in watershed characteristics from increased urbanization that could be affecting the watersheds for gages BALC6 and COYC1 were not affecting the gage TOPG1 watershed. This is a reasonable assumption given that the gage TOPG1 watershed is in the Santa Monica Mountains and is likely not as affected by increased imperviousness from higher-density development, whereas the gages BALC6 and COYC1 watersheds are in areas where imperviousness has likely increased through time. An increase in imperviousness through time would tend to cause an overestimation of streamflow for earlier records and an underestimation of streamflow for more recent records.

## Alhambra Wash (gage ALHW6)

The NSME calibration results for gage ALHW6 on Alhambra Wash were good for daily streamflow and excellent

for monthly streamflow, but poor for annual streamflow (fig. 30; table 10). Although the PAEE results of  $-18$  for daily and monthly flow and  $-14$  for annual flow indicated noteworthy estimation bias by an overall underestimation of streamflow, the results were still considered satisfactory in this study. The gage ALHW6 calibration for monthly streamflow provided the greatest NSME value of 0.94. In general, the hydrographs indicated a better fit to daily and monthly streamflow for the earlier records than the later ones (figs. 30A, B). The annual hydrograph indicated the best fit to the mid-study records, from about water year 1948 to 1991 (fig. 30C). For the annual flows, the model consistently overestimated streamflow prior to about water year 1948 and consistently underestimated streamflow after water year 1991. This temporal drift in estimation bias was consistent with the drift in estimation bias for gages BALC6 and COYC1 and can be explained by an increase in impervious land cover caused by increasing urbanization through time.

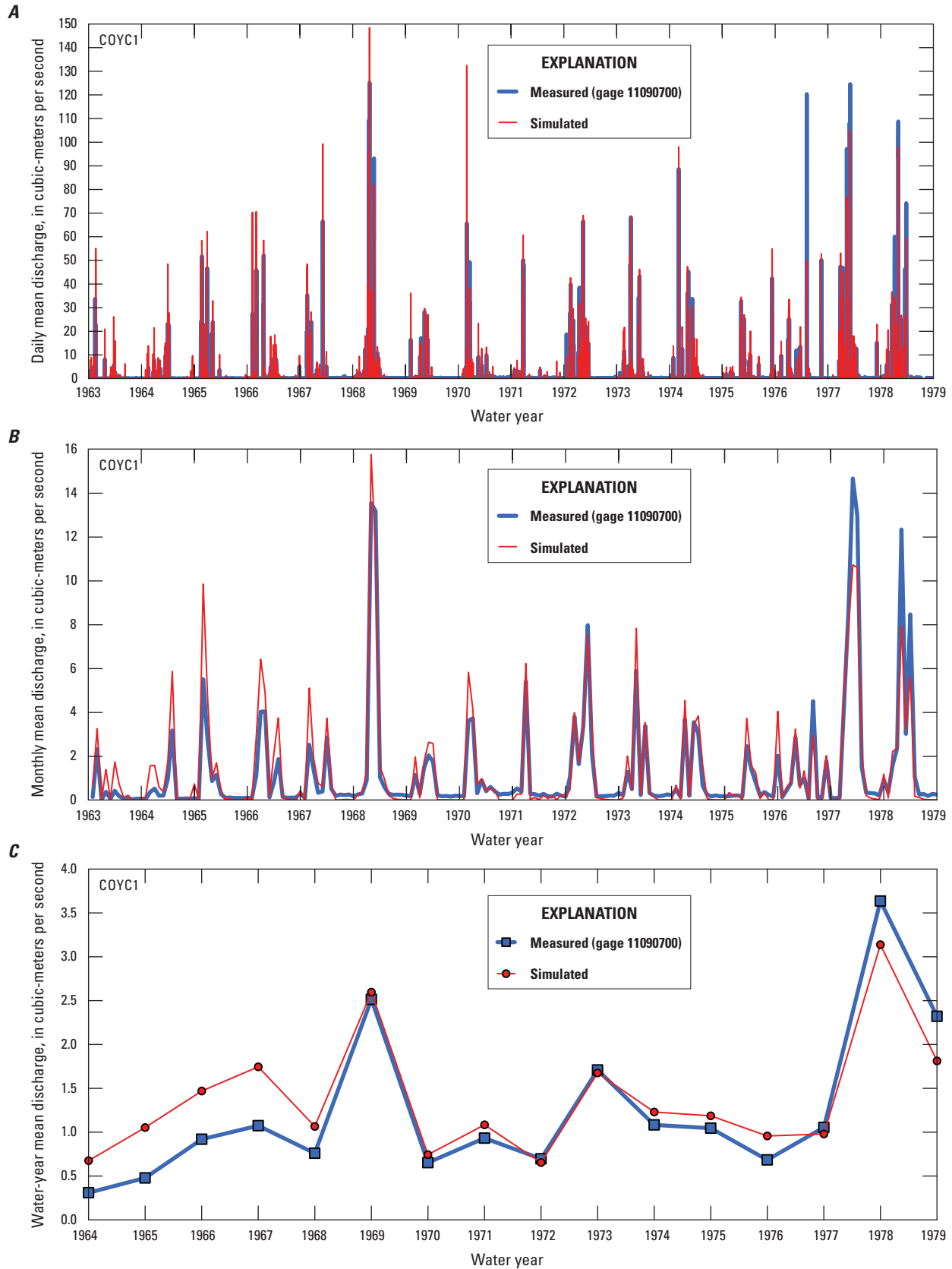
## San Jose Creek (SJCE1)

Calibration results for gage SJCE1 ranged from good to excellent in terms of the NSME statistic, with the best fit being achieved for monthly streamflow (fig. 31; table 10). Similar to the results for gage ALHW6, the PAEE statistic of  $-16$  to  $-15$  indicated a tendency for the model to underestimate streamflow at this gage. The daily hydrograph indicated some over- and underestimation of peak flows, and the annual hydrograph indicated a general tendency of the model to underestimate annual flows. The monthly hydrograph indicated that streamflow was primarily underestimated during low-flow conditions, when managed flows from upstream reservoir operations can be the primary source of streamflow. The consistent underestimation during low flows caused the PAEE statistic to be only satisfactory for this gage; otherwise, there was a very good match to the peak daily and monthly flows.

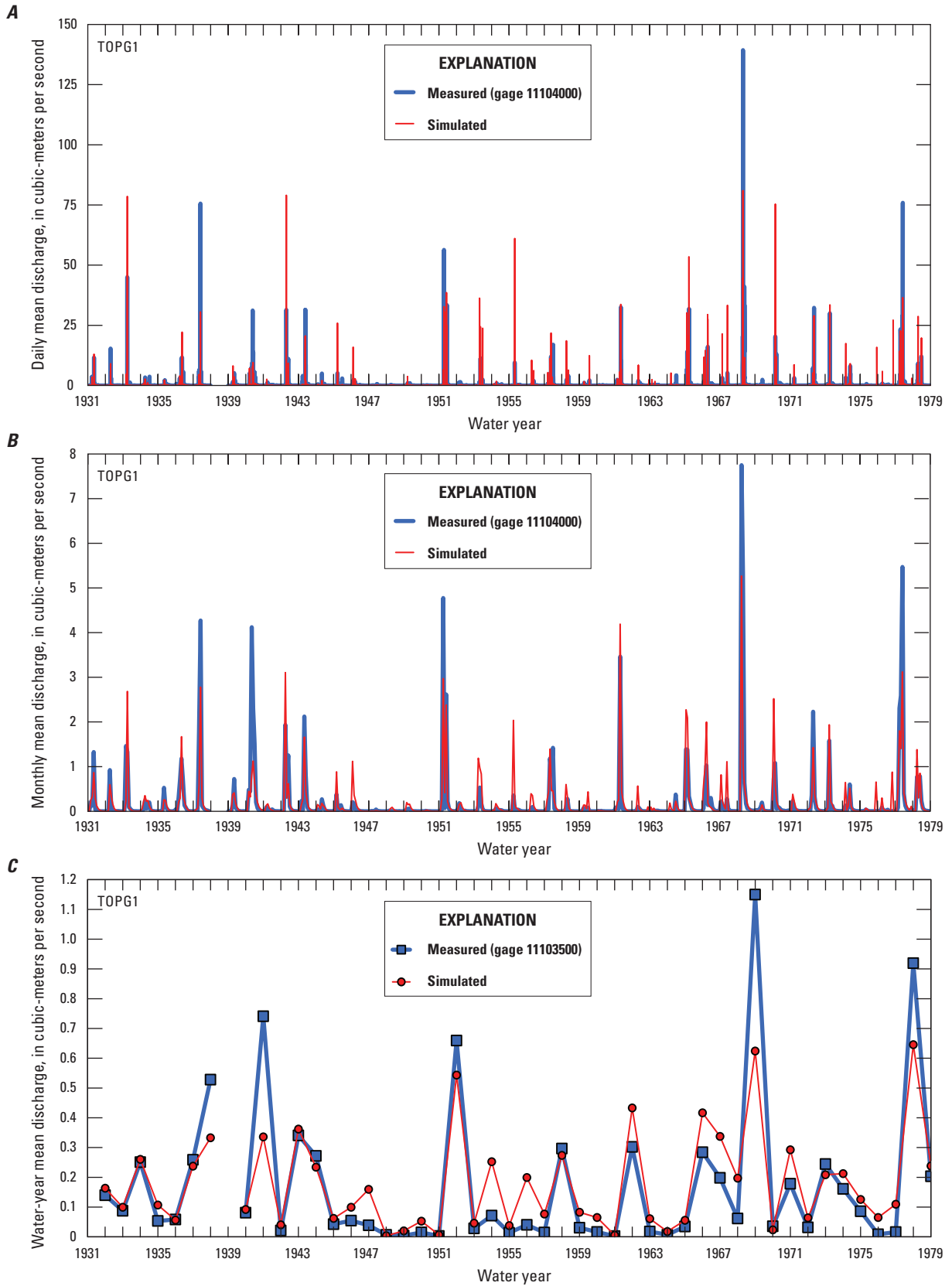
## Monthly Streamflow

Comparison of the scatterplots of simulated against measured monthly streamflow for each gage relative to the one-to-one line was used for a qualitative assessment of model calibration. The scatterplots indicated a good overall fit between simulated and measured monthly streamflow at most streamflow-gaging stations (fig. 32). The best fit to the one-to-one line was indicated by the simulated monthly streamflows for the BALC6, SJCE1, and COYC1 gages. Although gage ALHW6 had the best monthly NSME result at 0.94, the scatterplot indicated a systematic underestimation of the higher monthly flows. The poorest calibration result was indicated for gage TOPG1, which showed a consistent underestimation of the higher monthly flows.

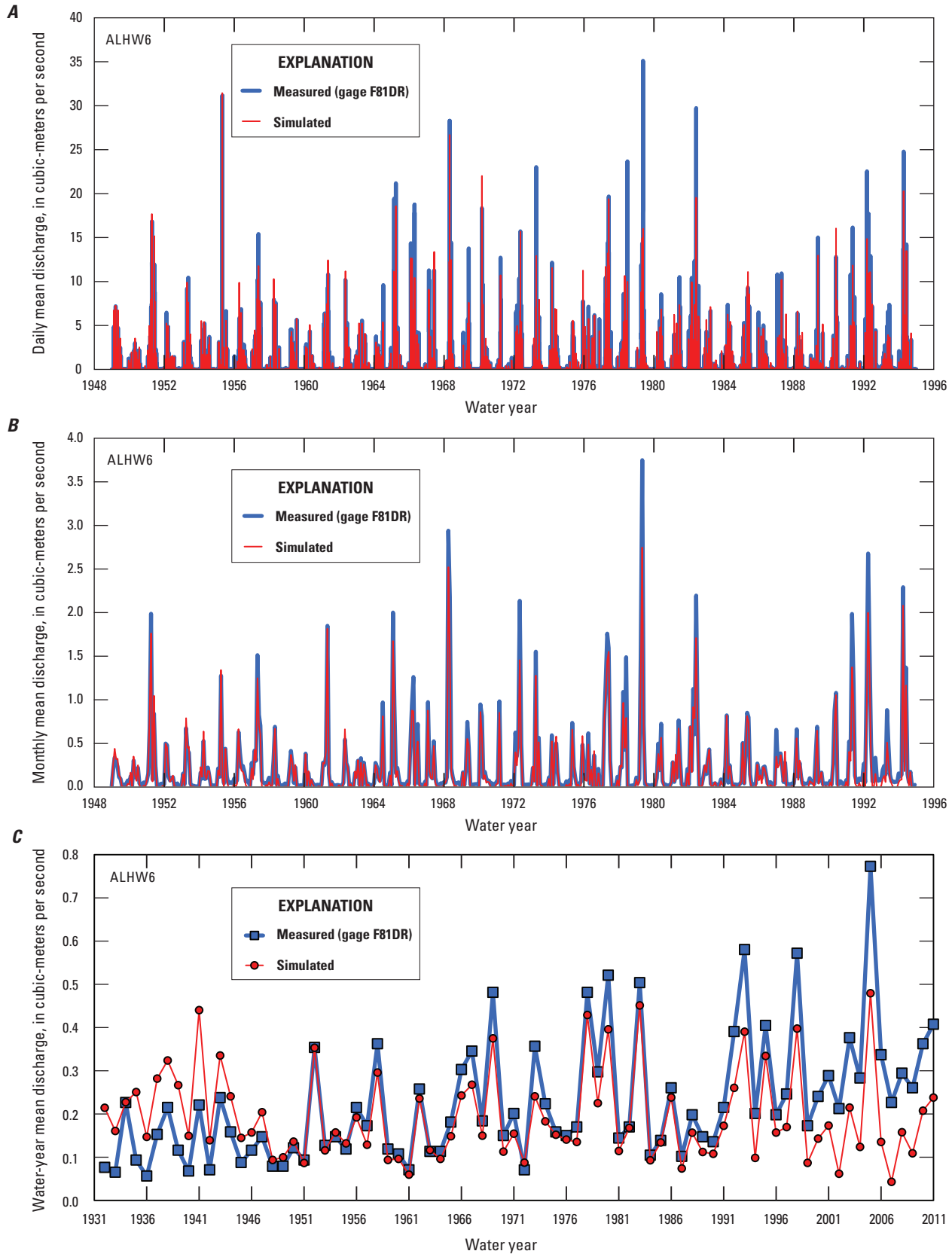




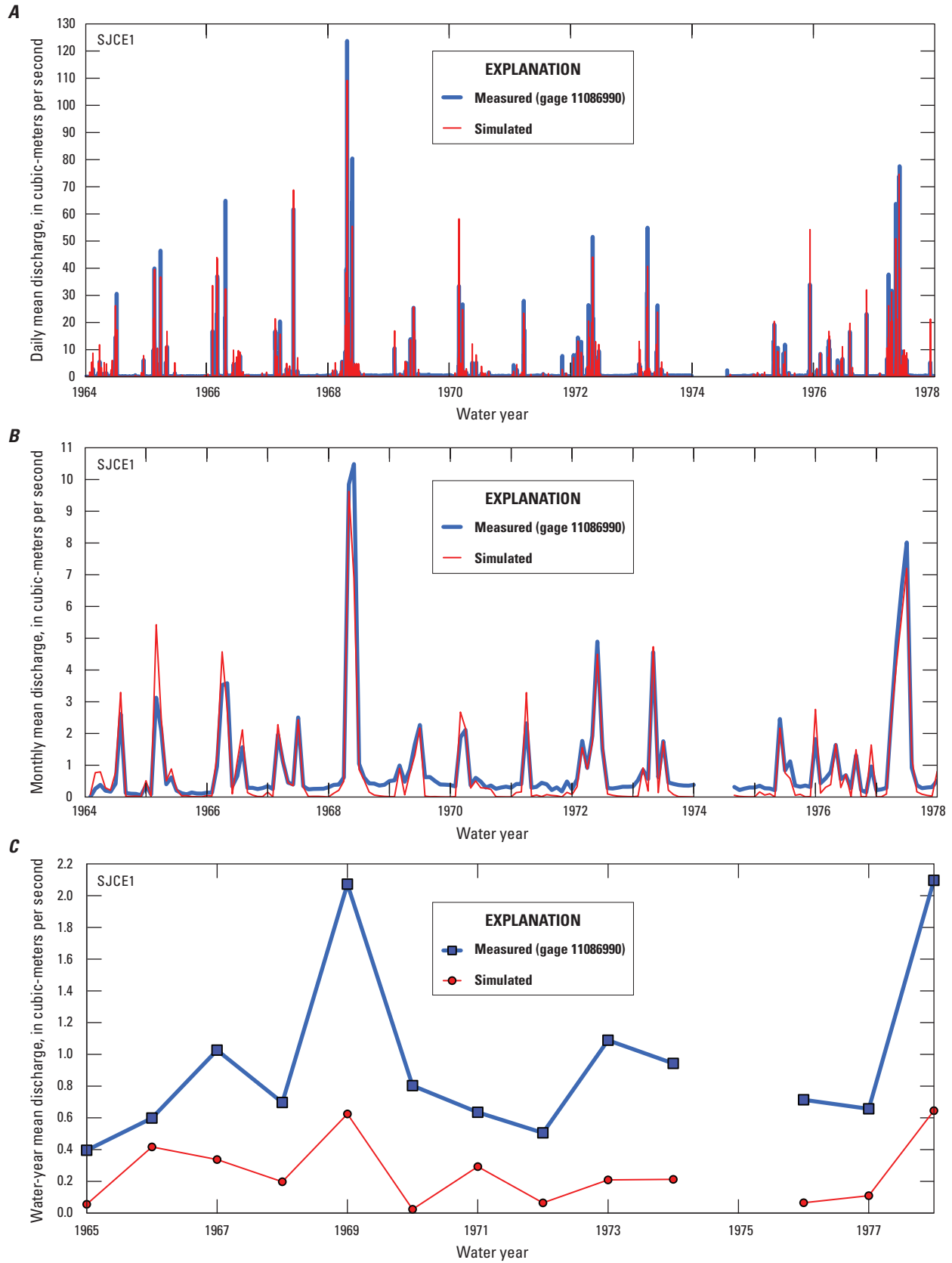
**Figure 28.** Comparison of simulated and measured streamflow at gage COYC1, Los Angeles Basin watershed model (LABWM), California: A, daily; B, monthly; C, annually.



**Figure 29.** Comparison of simulated and measured streamflow at gage TOPG1, Los Angeles Basin watershed model (LABWM), California: A, daily; B, monthly; C, annually.

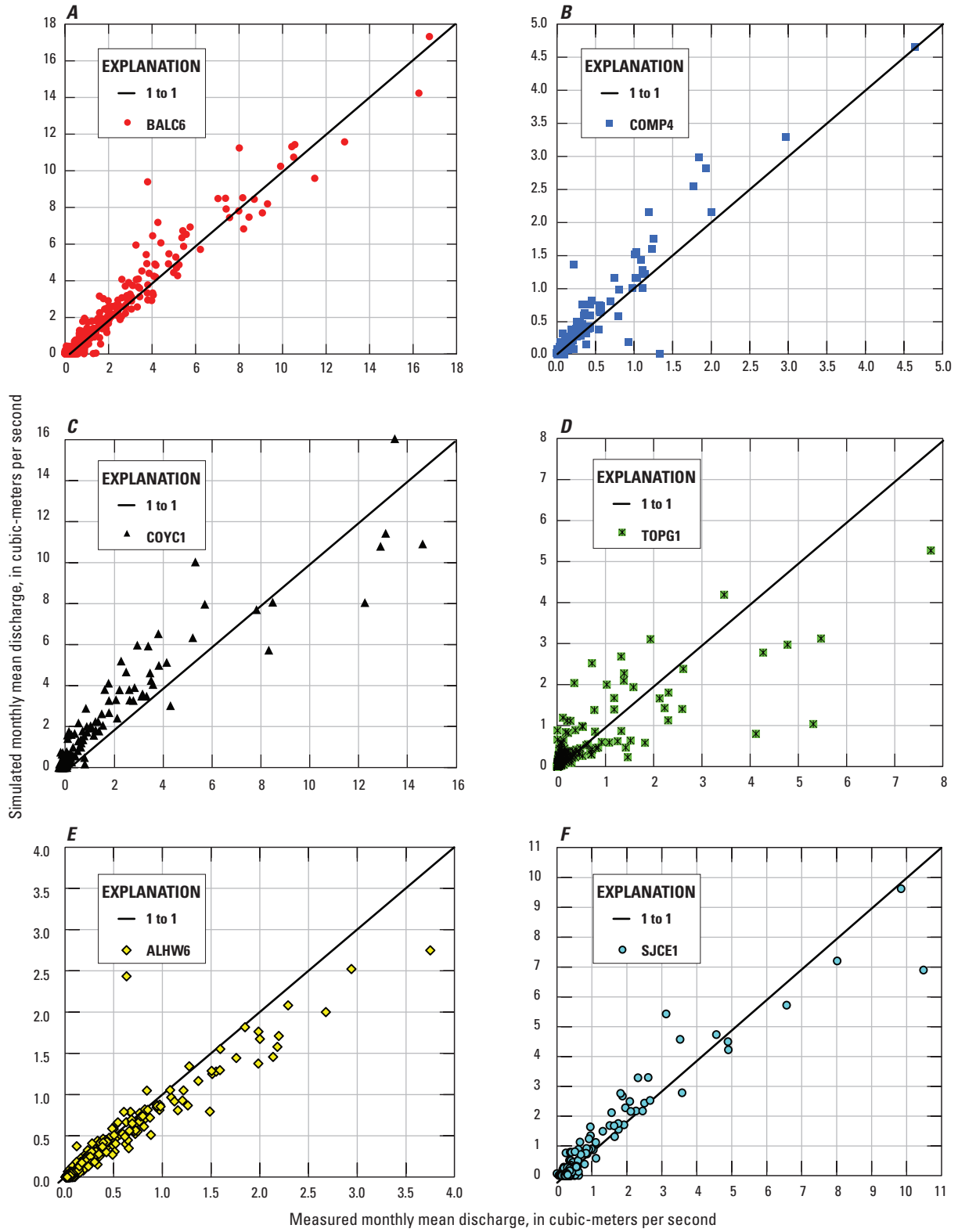


**Figure 30.** Comparison of simulated and measured streamflow at gage ALHW6, Los Angeles Basin watershed model (LABWM), California: A, daily; B, monthly; C, annually.



**Figure 31.** Comparison of simulated and measured streamflow at gage SJCE1, Los Angeles Basin watershed model (LABWM), California: A, daily; B, monthly; C, annually.





**Figure 32.** Simulated against measured monthly streamflow, Los Angeles Basin watershed model (LABWM), California, at gage A, BALC6; B, COMP4; C, COYC1; D, TOPG1; E, ALHW6; F, SJCE1.

## Annual Streamflow

Comparison of the scatterplots of simulated against measured annual (water year) streamflow to the one-to-one line for each gage also was used for a qualitative assessment of model calibration (fig. 33). The scatterplot provided an indication of the combined calibration based on all six gages. The results indicated a strong correlation between simulated and measured flows, and a good overall fit to the one-to-one line. A slight tendency of the LABWM to underestimate the largest annual streamflows was indicated by the results for gage BALC6 (fig. 33A). Overall, the combined results did not indicate a strong bias in terms of a systematic over- or underestimation of annual streamflow, except at the very low annual streamflows of 0.5 cubic meters per second ( $\text{m}^3/\text{s}$ ) and less measured at gage TOPG1, which the LABWM showed a tendency to systematically overestimate (fig. 33B).

## Model Sensitivity

A quantitative model-sensitivity analysis was not performed in this study. A qualitative analysis of model sensitivity was done as part of the calibration procedure, however. Simulated streamflow was found to be sensitive to estimated root-zone thickness, soil hydraulic conductivity, percentage of impervious area, and precipitation type (rain or snow). Areas that had a thinner soil cover (generally the undeveloped mountainous areas), lower soil hydraulic conductivity, and higher percentage of impervious area generated greater runoff. In addition, runoff generation (the overland-flow component of streamflow) was found to be sensitive to the estimated hydraulic conductivity for layer 6 (parameters defined in part by surficial geology). Low values of hydraulic conductivity for layer 6 resulted in a greater potential for the generation of saturation excess (Dunnian) runoff.

The seepage-flow component of simulated streamflow, used in this study to represent baseflow, was found to be sensitive to the estimated hydraulic conductivity for layers 6 and 7 and slope. A greater hydraulic conductivity and slope resulted in more seepage (and less overland flow). Parameter values that increased seepage tended to also decrease the runoff component of streamflow.

Simulated recharge was found to be most sensitive to soil thickness and the estimated hydraulic conductivity for layers 6 and 7. In general, parameter values causing an increase in recharge also resulted in a decrease in runoff along with a decrease in ET. Runoff, recharge, and ET were all very sensitive to spatially interpolated precipitation. The effect of air temperature on the simulation of precipitation as rain or snow was also found to be a critical input for the higher elevation drainages in the San Gabriel Mountains. Precipitation as rain caused an increase in streamflow in direct

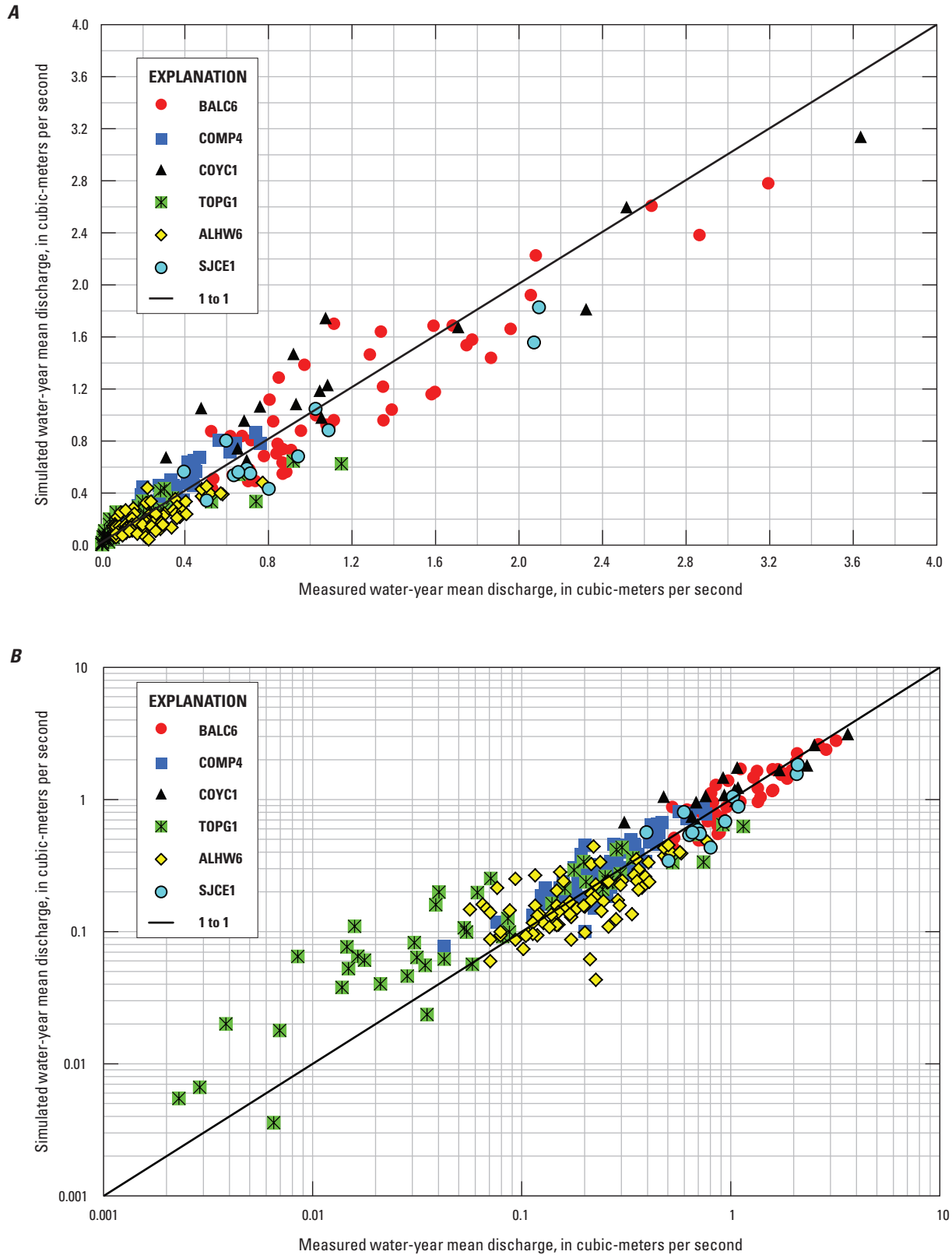
response to the storm event. Precipitation as snow caused a delayed response in runoff and recharge and usually resulted in lower streamflow than if the precipitation had been rain. Unlike soil thickness and hydraulic conductivity, precipitation and air temperature were not adjusted during the calibration process.

## Calibration Summary

Results for four gages, ALHW6, SJCE1, BALC6, and COYC1, indicated a change in estimation bias from overestimating streamflow in the early part of the record to underestimation of streamflow in the later part of the record. The observed shift in estimation bias was likely to have been caused by changes in watershed characteristics for which the model did not account. For example, an increase in imperviousness caused by the growth of urbanized areas and developed lands would tend to cause an increase in runoff during storms. Other factors that could cause an increase in runoff during storms include loss of vegetation due to fire or land development and the conversion of natural channels to engineered channels. In addition to an increase in storm runoff, urbanization and land development can cause an increase in low flows in response to wastewater discharges and increased irrigation runoff during the dry months. The development of flood-control features, flow diversions, and spreading grounds also cause changes in the flow characteristics of a watershed. In some cases, the storage of storm runoff in reservoirs upstream from the stream gage used for calibration can result in a reduction in water-year runoff because of evaporation and seepage losses from reservoirs. For this study, however, a consistent trend of decreasing water-year runoff was not identified by using the average water year runoff for the six calibration gages.

## Model Application

By using the calibrated LABWM, simulations were run for the 12 model subdomains (fig. 9). The daily simulation period was January 1, 1905, to September 30, 2014, and included a 9.75 year model-initialization period (January 1, 1905, through September 30, 2014) and a 100-year target-simulation period for water years 1915–2014 (October 1, 1914, through September 30, 2014). Results from the 12 model subdomains were combined to develop maps of average annual values and average monthly values for various components of the simulated water budget. The combined results were used to calculate the total potential recharge in the Los Angeles recharge-study area, including the direct recharge component in the LAGSA as well as the mountain-front recharge component from tributary upland areas bordering the LAGSA.



**Figure 33.** Simulated against measured annual streamflow at six gages used for model calibration, Los Angeles Basin watershed model (LABWM), California: *A*, normal scale; *B*, log-scale.

## Simulation Results, Water Years 1915–2014

Simulation results for water years 1915–2014 were used to map the 100-year averages for components of the water budget, including PET, ET, streamflow, and recharge. The mapped results were used to analyze the distribution patterns of the water-budget components and to identify areas of maximum and minimum values.

### Potential Evapotranspiration

Simulated average annual PET for water years 1915–2014 ranged from high values of 1,437 mm/yr for low-lying, south-facing slopes in the hilly and mountainous regions of the LABWM area to low values of 550 mm/yr for the steeper, north-facing slopes in the San Gabriel Mountains (fig. 34). A basin-wide average PET rate of 1,237 mm/yr was simulated for the LABWM area (table 11). The average PET for subbasins ranged from a minimum of 1,188 mm/yr for the upper San Gabriel River to a maximum of 1,274 mm/yr for Rio Hondo. Lower PET rates were simulated for the coastal areas compared to the inland areas. The overall distribution of simulated PET was comparable to published reference ET ( $ET_o$ ) zones 4, 6, 9, and 14 for California (California Irrigation Management Information System (CIMIS), 2005), showing reference  $ET_o$  of about 1,450 mm/yr for inland areas (zone 14) and 1,180 mm/yr for the Los Angeles urban area (zone 4).

A basin-wide average PET rate of 1,258 mm/yr was simulated for the LAGSA (table 12). In general, the differences in basin-wide average PET among the groundwater basins were small, with a maximum PET of 1,285 mm/yr simulated for the Whittier Area groundwater basin and a minimum of 1,240 mm/yr simulated for the Santa Monica groundwater basin.

### Evapotranspiration

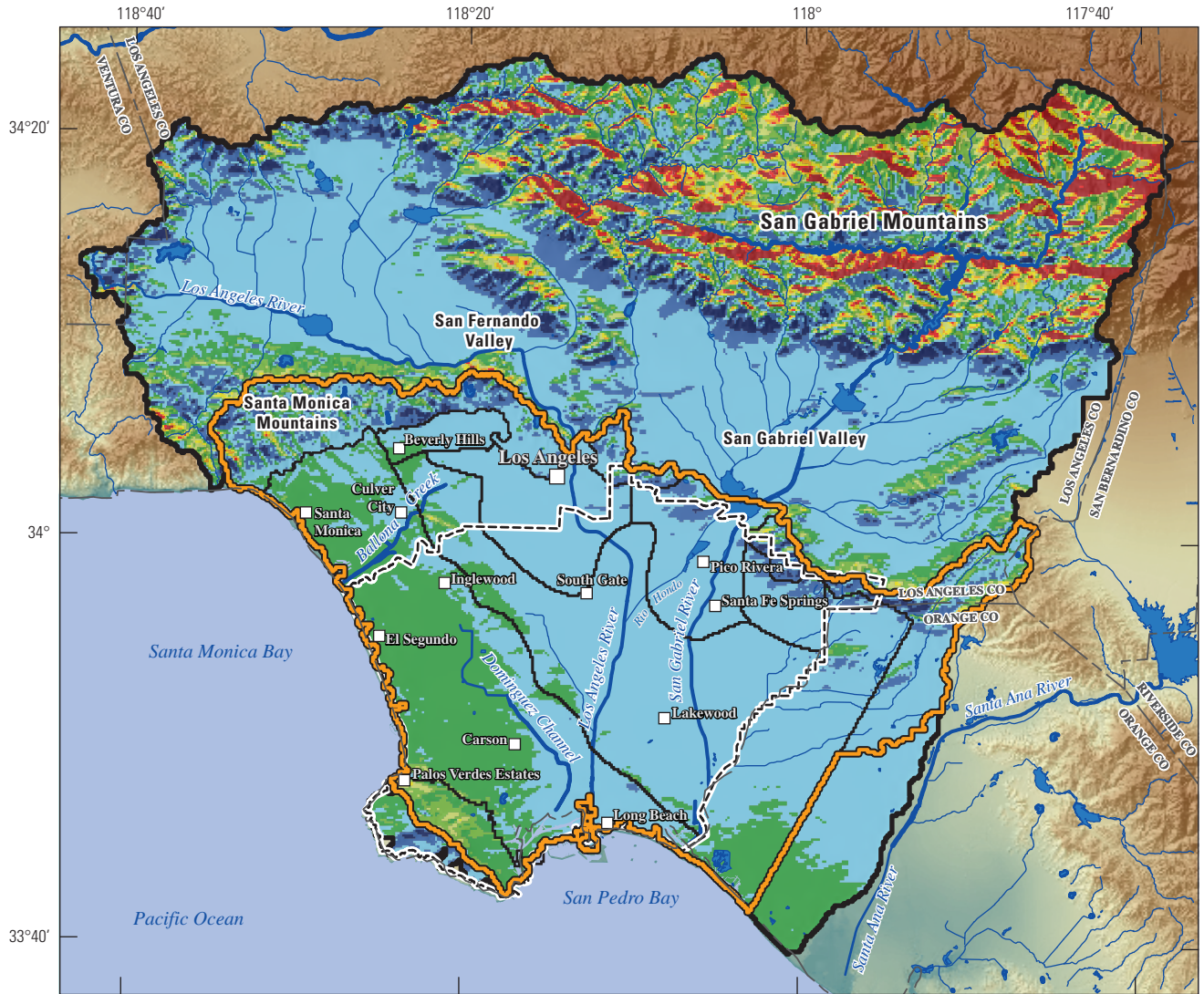
The highest maximum ET rates of 701 to 1,104 mm/yr were simulated for south-facing slopes in the San Gabriel and Santa Monica Mountains, and also for irrigated pervious cells in urban areas (fig. 35). The lowest ET rates of 0 to 100 mm/yr were simulated for impervious areas of urban centers and also for water bodies (the LABWM does not simulate evaporation from water bodies or impervious surfaces). The 100-year basin-wide average ET rate simulated for the LABWM area was 362 mm/yr (table 11), and the 100-year basin-wide average ET rate simulated for the LAGSA was 297 mm/yr (table 12). In the LABWM area, the upper San Gabriel River subdomain had the highest ET rate at 444 mm/yr, and in the LAGSA, the Whittier Area groundwater basin had the highest ET rate at 380 mm/yr. In general, the higher ET rates were simulated for the more pervious cells receiving larger precipitation amounts in the mountainous

areas, urban irrigation, or a combination of both these things. Compared to other subdomains, the upper San Gabriel River subdomain had the highest 100-year precipitation rate at 669 mm/yr (table 11). Compared to other groundwater basins, the Whittier Area had the highest urban irrigation rate of 184 mm/yr (table 12). In the developed and urbanized land areas, higher ET was also simulated for cells downstream from more impervious cells that tended to generate runoff (fig. 35).

### Runoff

Results for runoff included the combined simulated runoff from overland and seepage flows. The average annual simulated runoff for water years 1915–2014 included a maximum runoff of 9.5 m<sup>3</sup>/s simulated for the cells representing the lower reaches of the main channel of the Los Angeles River downstream from the confluence with the Rio Hondo near the mouth of the San Gabriel River (fig. 36). Relatively high average runoff rates up to 2 m<sup>3</sup>/s were simulated for the lower section of Ballona Creek, Rio Hondo, the upper sections of the Los Angeles and San Gabriel Rivers, and near the mouth of the Dominguez Channel. Low to intermediate average runoff rates of 0.11 to 1 m<sup>3</sup>/s were simulated for the tributaries draining into the main channels of the lowlands and also the headwater drainages in the San Gabriel Mountains. Relatively low average annual runoff rates of 0.01 to 0.1 m<sup>3</sup>/s were simulated for the first- and second-order drainages represented by the majority of the stream channels in the LABWM area. The average-annual runoff rate simulated for the LABWM area was 145 mm/yr, which was about 30 percent of the average annual precipitation rate and 26 percent of the combined average inflows from precipitation and urban irrigation (table 11). The upper San Gabriel River subdomain had the highest simulated-runoff rate at 192 mm/yr. In comparison, the lower Santa Monica Basin subdomain had the lowest runoff rate at 84 mm/yr. The highest surface-water outflow of 812 mm/yr was simulated for the lower Los Angeles River subdomain, which included a combined surface-water inflow of 643 mm/yr from the upstream subdomains upper Los Angeles River and Rio Hondo in addition to the 169 mm/yr runoff generated in the lower Los Angeles River subdomain. The average 100-year runoff simulated for the LAGSA was 140 mm, or about 42 percent of the average precipitation of 336 mm/yr (table 12). Excluding the surface-water inflows from the three major surface-water drainages upstream from the LAGSA (the Los Angeles River, the San Gabriel River, and the Rio Hondo), inflow of runoff from mountain-front drainages bordering the LAGSA averaged 24 mm/yr for the 100-year simulation, resulting in a total simulated surface-water discharge of 164 mm/yr from the LAGSA. The Hollywood groundwater basin had the highest average surface-water inflow at 136 mm/yr and also had the highest average surface-water discharge at 324 mm/yr (table 12).





Base modified from U.S. Geological Survey and other State digital data, various scales  
 Universal Transverse Mercator, zone 11  
 North American Datum 1983



**EXPLANATION**

<b>Los Angeles Basin watershed model simulated 1915–2014 potential evapotranspiration, in millimeters per year</b>		Los Angeles Basin watershed model area boundary
550–950	1,151–1,200	Water Replenishment District
951–1,000	1,201–1,250	Los Angeles recharge study area
1,001–1,050	1,251–1,300	Water bodies and flood-control areas
1,051–1,100	1,301–1,350	Major rivers and streams
1,101–1,150	1,351–1,437	Minor rivers and streams
		Los Angeles groundwater basins
		County line

**Figure 34.** Average annual potential evapotranspiration simulated for water years 1915–2014 by using the Los Angeles Basin watershed model (LABWM), California.

**Table 11.** Summary of average inflows, outflows, and changes in storage for total model area and model subdomains, water years 1915–2014, Los Angeles Basin watershed model (LABWM), California.

[ha-m/yr, hectare-meter per year; mm/yr, millimeter per year]

Model area and subdomains	Units	Potential			Inflows			Generated			Outflows			Change in storage
		evapo-transpiration	Precipitation	Surface water	Urban irrigation	Surface water	Sublimation	Evapo-transpiration	Recharge	Surface water	Sublimation	Evapo-transpiration	Recharge	
Los Angeles Basin watershed model (LABWM)	mm/yr	1,237	488	0	63	145	1	362	45	145	-1			
Los Angeles Basin watershed model (LABWM)	ha-m/yr	624,391	246,405	0	31,906	73,212	465	182,473	22,577	73,212	-417			
Subbasins														
Ballona Creek (BALC)	mm/yr	1,261	394	0	135	144	0	336	51	144	-1			
Ballona Creek (BALC)	ha-m/yr	42,647	13,329	0	4,576	4,864	0	11,359	1,723	4,864	-42			
Dominquez Channel (DOMC)	mm/yr	1,237	324	0	118	139	0	270	34	139	-1			
Dominquez Channel (DOMC)	ha-m/yr	37,871	9,917	0	3,616	4,244	0	8,276	1,039	4,244	-26			
Lower Los Angeles River (LARV)	mm/yr	1,271	353	643	122	169	0	269	38	812	-1			
Lower Los Angeles River (LARV)	ha-m/yr	47,618	13,213	24,102	4,573	6,325	0	10,095	1,407	30,427	-40			
Long Beach (LONG)	mm/yr	1,259	300	0	120	123	0	273	25	123	-1			
Long Beach (LONG)	ha-m/yr	2,287	546	0	218	224	0	496	45	224	-1			
Lower Santa Monica Basin (LSMB)	mm/yr	1,238	328	0	144	84	0	346	43	84	-1			
Lower Santa Monica Basin (LSMB)	ha-m/yr	11,809	3,128	0	1,371	801	0	3,300	406	801	-7			
Rio Hondo (RIOH)	mm/yr	1,274	541	0	73	169	0	409	36	169	-1			
Rio Hondo (RIOH)	ha-m/yr	42,299	17,966	0	2,414	5,622	15	13,570	1,212	5,622	-40			
Seal Beach (SEAL)	mm/yr	1,249	301	0	139	100	0	309	32	100	-1			
Seal Beach (SEAL)	ha-m/yr	26,817	6,459	0	2,978	2,153	0	6,623	684	2,153	-24			
Lower San Gabriel River (SGRV)	mm/yr	1,268	342	371	131	108	0	327	39	479	-1			
Lower San Gabriel River (SGRV)	ha-m/yr	75,983	20,515	22,206	7,832	6,496	0	19,563	2,350	28,702	-63			
Topanga Creek (TOPC)	mm/yr	1,240	566	0	0	106	0	310	150	106	-0			
Topanga Creek (TOPC)	ha-m/yr	6,381	2,913	0	0	546	0	1,597	771	546	-0			
Upper Los Angeles River (ULAR)	mm/yr	1,237	523	0	4	127	1	359	41	127	-0			
Upper Los Angeles River (ULAR)	ha-m/yr	179,584	75,919	0	648	18,481	93	52,164	5,893	18,481	-63			
Upper San Gabriel River (USGR)	mm/yr	1,188	669	0	24	192	3	444	54	192	-1			
Upper San Gabriel River (USGR)	ha-m/yr	137,449	77,368	0	2,732	22,206	357	51,412	6,228	22,206	-104			
Upper Santa Monica Basin (USMB)	mm/yr	1,253	471	0	87	115	0	369	75	115	-1			
Upper Santa Monica Basin (USMB)	ha-m/yr	13,644	5,132	0	949	1,252	0	4,017	820	1,252	-9			

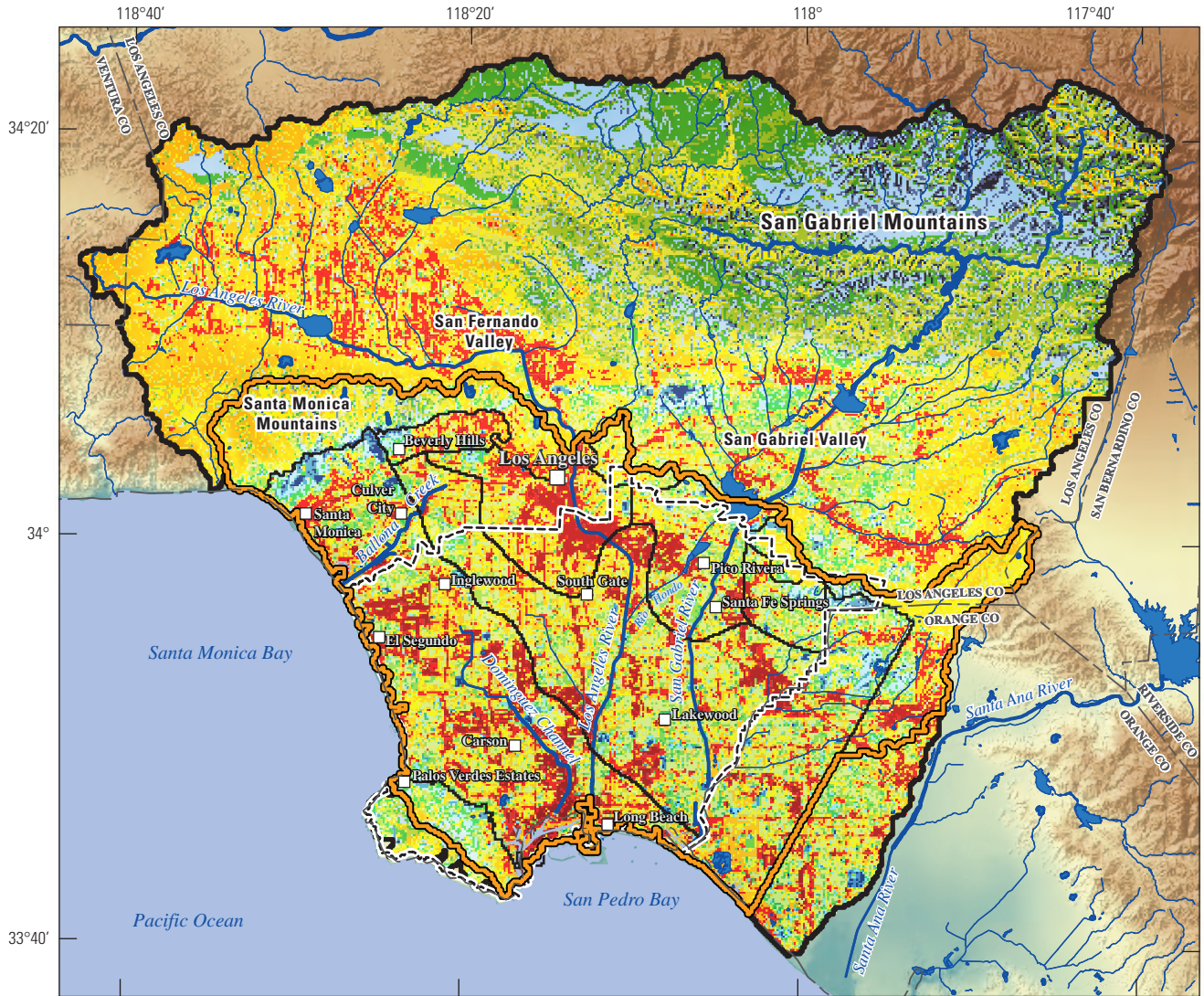
**Table 12.** Summary of average inflows, outflows, and changes in storage for the Los Angeles groundwater basins and Los Angeles groundwater study area, water years 1915–2014, Los Angeles Basin watershed model (LABWM), California.

[ET, evapotranspiration; ha-m/yr, hectare-meter per year; mm/yr, millimeter per year; nc, not collected]

Area name	Units	Potential ET	Inflows			Generated runoff	Outflows			Change in storage	Potential mountain-front recharge	Total potential recharge
			Precipitation	Surface water	Urban irrigation		ET	Direct recharge	Surface water			
Los Angeles groundwater study area (LAGSA)	mm/yr	1,258	336	24	135	140	297	35	164	-1	18	53
	ha-m/yr	187,240	50,005	3,579	20,075	20,815	44,227	5,218	24,395	-180	2,687	7,906
Groundwater basins												
Montebello Forebay	mm/yr	1,283	363	8	133	139	315	43	147	-1	7	50
	ha-m/yr	16,055	4,546	102	1,660	1,741	3,943	538	1,843	-17	92	630
Central Basin Pressure <sup>1</sup>	mm/yr	1,260	332	nc	149	145	298	39	145	-1	0	39
	ha-m/yr	53,504	14,112	nc	6,327	6,176	12,675	1,646	6,176	-58	0	1,646
West Coast Basin	mm/yr	1,243	317	10	116	138	261	35	148	-1	6	41
	ha-m/yr	46,844	11,937	377	4,361	5,194	9,837	1,302	5,571	-36	232	1,534
Orange County	mm/yr	1,259	314	46	142	98	333	26	143	-1	31	57
	ha-m/yr	28,262	7,044	1,022	3,184	2,197	7,466	590	3,219	-24	695	1,285
Whittier area	mm/yr	1,285	350	12	184	118	380	38	129	-2	15	53
	ha-m/yr	6,072	1,653	56	871	557	1,795	180	612	-7	69	249
Los Angeles Forebay	mm/yr	1,276	364	56	104	202	234	32	257	-1	20	52
	ha-m/yr	17,298	4,934	754	1,404	2,738	3,180	432	3,492	-12	267	699
Hollywood	mm/yr	1,263	398	136	134	188	310	36	324	-2	100	136
	ha-m/yr	4,440	1,399	479	473	661	1,091	126	1,140	-6	353	480
Santa Monica	mm/yr	1,240	368	66	151	130	356	34	197	-2	82	116
	ha-m/yr	14,764	4,379	790	1,797	1,552	4,241	402	2,341	-19	981	1,383

<sup>1</sup> Surface-water inflow for Central Basin Pressure was not calculated and was not included in the estimated water balance





Base modified from U.S. Geological Survey and other State digital data, various scales  
 Universal Transverse Mercator, zone 11  
 North American Datum 1983

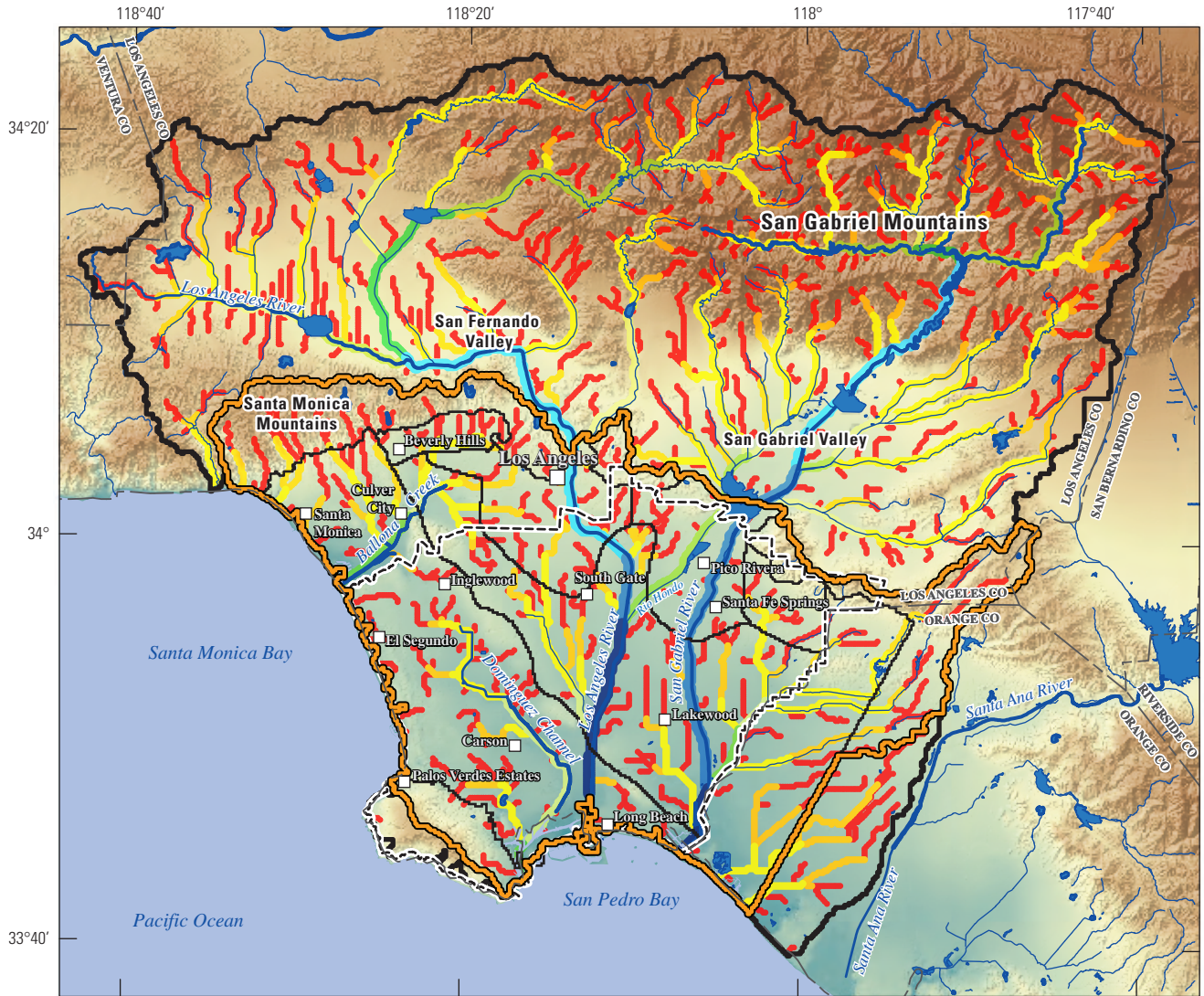


**EXPLANATION**

<b>Los Angeles Basin watershed model simulated 1915–2014 actual evapotranspiration, in millimeters per year</b>		Los Angeles Basin watershed model area boundary
0–100	401–450	Water Replenishment District
101–200	451–500	Los Angeles recharge study area
201–300	501–600	Water bodies and flood-control areas
301–350	601–700	Major rivers and streams
351–400	701–1,104	Minor rivers and streams
		Los Angeles groundwater basins
		County line

**Figure 35.** Spatially distributed average annual evapotranspiration simulated for water years 1915–2014 by using the Los Angeles Basin watershed model (LABWM), California.





Base modified from U.S. Geological Survey and other State digital data, various scales  
 Universal Transverse Mercator, zone 11  
 North American Datum 1983



**EXPLANATION**

- |  |   |
|--|---|
| <p><b>Los Angeles Basin watershed model simulated 1915–2014 average streamflow, in cubic-meters per second</b></p> <ul style="list-style-type: none"> <li>• 0.010–0.050</li> <li>• 0.051–0.100</li> <li>• 0.110–0.500</li> <li>• 0.510–1.000</li> <li>• 1.100–2.000</li> <li>• 2.100–4.000</li> <li>• 4.100–6.000</li> <li>• 6.100–8.000</li> <li>• 8.100–9.500</li> </ul> | <ul style="list-style-type: none"> <li>▭ Los Angeles Basin watershed model area boundary</li> <li>▭ Water Replenishment District</li> <li>▭ Los Angeles recharge study area</li> <li>▭ Water bodies and flood-control areas</li> <li>▬ Major rivers and streams</li> <li>▬ Minor rivers and streams</li> <li>▬ Los Angeles groundwater basins</li> <li>▬ County line</li> </ul> |
|--|---|

**Figure 36.** Simulated average streamflow for water years 1915–2014 by using the Los Angeles Basin watershed model (LABWM), California.

## Recharge

The average-annual simulated recharge for water years 1915–2014 was 45 mm/yr for the LABWM area (table 11). This recharge rate was about 9 percent of the precipitation rate, and about 8 percent of the combined inflow rate of precipitation and urban irrigation. As would be expected, the spatially distributed recharge rate varied notably (fig. 37). The highest average recharge values of 200 to 1,810 mm/yr were simulated for stream channels that received large surface-water inflows from upstream areas and also had relatively permeable soil and underlying rock layers. In the low-lying urbanized areas, relatively high recharge rates of more than 50 mm/yr were mostly in the irrigated areas subject to frequent inflows from upstream impervious areas in addition to continuous inflows from irrigation. For most low-lying urbanized areas, however, simulated recharge was negligible (less than 1 mm/yr). Recharge tended to be higher in upland areas that have relatively more precipitation and thin soils underlain by permeable rock units. The Topanga Creek subdomain had the highest recharge rate at 150 mm/yr, about 26 percent of the precipitation rate of 566 mm/yr (table 11). The Long Beach subdomain had the lowest recharge rate at 25 mm/yr, about 6 percent of the combined precipitation and urban irrigation inflow of 420 mm/yr (table 11).

The average 100-year simulated direct recharge for the LAGSA was 35 mm/yr, or about 10 percent of the simulated precipitation and about 7 percent of the total combined inflow of 495 mm/yr from precipitation, surface-water inflow, and urban irrigation (table 12). The direct-recharge component only included recharge from the net infiltration of precipitation, irrigation, and surface water through the root zone; it did not account for mountain-front recharge as underflow to the groundwater basin from bordering tributary drainages. In the LAGSA, the Montebello Forebay groundwater basin had the highest simulated direct recharge rate at 43 mm/yr, whereas the Orange County groundwater basin had the lowest simulated direct recharge rate at 26 mm/yr.

## Annual Results

### Annual Time Series

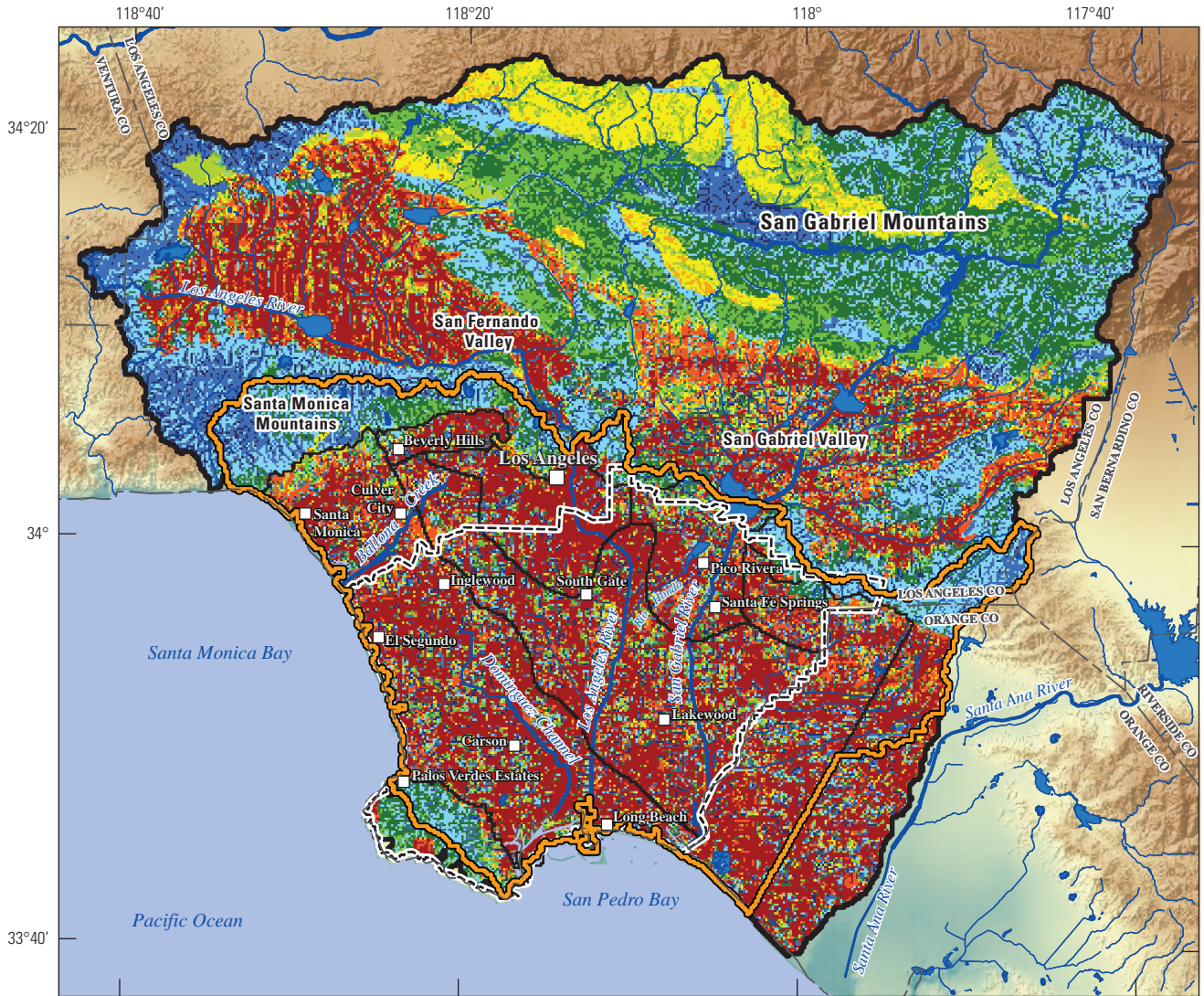
The 100-year time series of annual results were used to analyze the temporal variability of the simulated water-budget components for the LABWM area (appendix 1), the Los Angeles recharge-study area (appendix 2), and the LAGSA (appendix 3). With the exception of PET, the annual results for the LABWM area indicated a high degree of year-to-year variability in all components of the water budget (figs. 38A, B; appendix 1). Spatially interpolated, basin-wide annual precipitation ranged from a maximum of 566,000 ha-m for water year 2005 to a minimum of about 68,000 ha-m for water year 2007. In addition to water year 2007, three other water years—1961, 2002, and 2014—had annual precipitation

amounts less than 100,000 ha-m. In addition to water year 2005, five other water years had precipitation greater than 500,000 ha-m: 1941, 1978, 1983, 1993, and 1998. For all 100 water years, simulated basin-wide PET, which varied between about 589,000 and 665,000 ha-m for most water years, was greater than basin-wide precipitation for the LABWM area. After precipitation, the largest component of the LABWM area water budget was ET, which reached a maximum of about 274,000 ha-m during water year 1983 and a minimum of about 103,000 ha-m during water year 2007. In general, ET was strongly correlated to precipitation, but it exceeded precipitation during twenty one water years that had less than average precipitation (for water years 1924–25, 1942, 1948, 1951, 1959–61, 1964, 1970, 1981, 1984, 1987, 1990, 1994, 1999, 2002, 2007, and 2012–14), mostly because of the additional inflows from urban irrigation. Runoff was the third largest component of the LABWM area simulated water budget, with relatively high runoff amounts of more than 200,000 ha-m during the wettest water years: 1941, 1969, 1978, 1983, 1993, and 2005. Water year 2005, the wettest year, also had the most runoff at 246,000 ha-m. For many drier than average years, generally less than 200,000 ha-m of precipitation, runoff was less than 50,000 ha-m. Simulated recharge was a much smaller component of the LABWM area water budget compared to simulated ET and runoff. The maximum annual recharge of 85,000 ha-m was simulated for water year 1941, and other relatively high recharge amounts of more than 50,000 ha-m were simulated for water years 1969, 1978, 1980, 1983, 1993, 1998, and 2005 (fig. 38A).

The annual variability in basin-wide water-budget components for the Los Angeles recharge-study area was similar to the basin-wide results for the LABWM area (figs. 38C, D; appendix 2). Water years 1941, 1978, 1998, and 2005 were the wettest for the Los Angeles recharge-study area, with annual precipitation exceeding 150,000 ha-m. Annual ET was highest, more than 70,000 ha-m, during water years 1941, 1958, 1978, 1983, 1993, 1995, 1998, and 2005, all water years with annual precipitation of more than 100,000 ha-m. During the drier years, such as 1948, 1964, 2002, 2007, and 2014, ET was greater than precipitation because of urban irrigation of 24,000 ha-m. The annual runoff was greatest, more than 50,000 ha-m, in water years 1941, 1978, 1983, 1993, 1995, 1998, and 2005, with 2005 having the most runoff at 61,677 ha-m. The annual recharge amounts were highest, more than 20,000 ha-m, during these same water years; however, annual recharge was greatest, 34,000 ha-m, during water year 1941. The 100-year averages for the Los Angeles recharge-study area included a precipitation rate of 66,928 ha-meters per year (ha-m/yr), an ET rate of 58,021 ha-m/yr, a runoff rate of 24,745 ha-m/yr, and a recharge rate of 7,909 ha-m/yr.

For the LABWM area, the most recharge was simulated for the Topanga Creek (TOPC) subdomain, where annual recharge was as high as 545 mm for water year 1941 and 535 mm for water year 2005 (fig. 38E). The upper Santa Monica Basin (USMB) subdomain had the next highest recharge, with annual recharge of 267 mm for water year





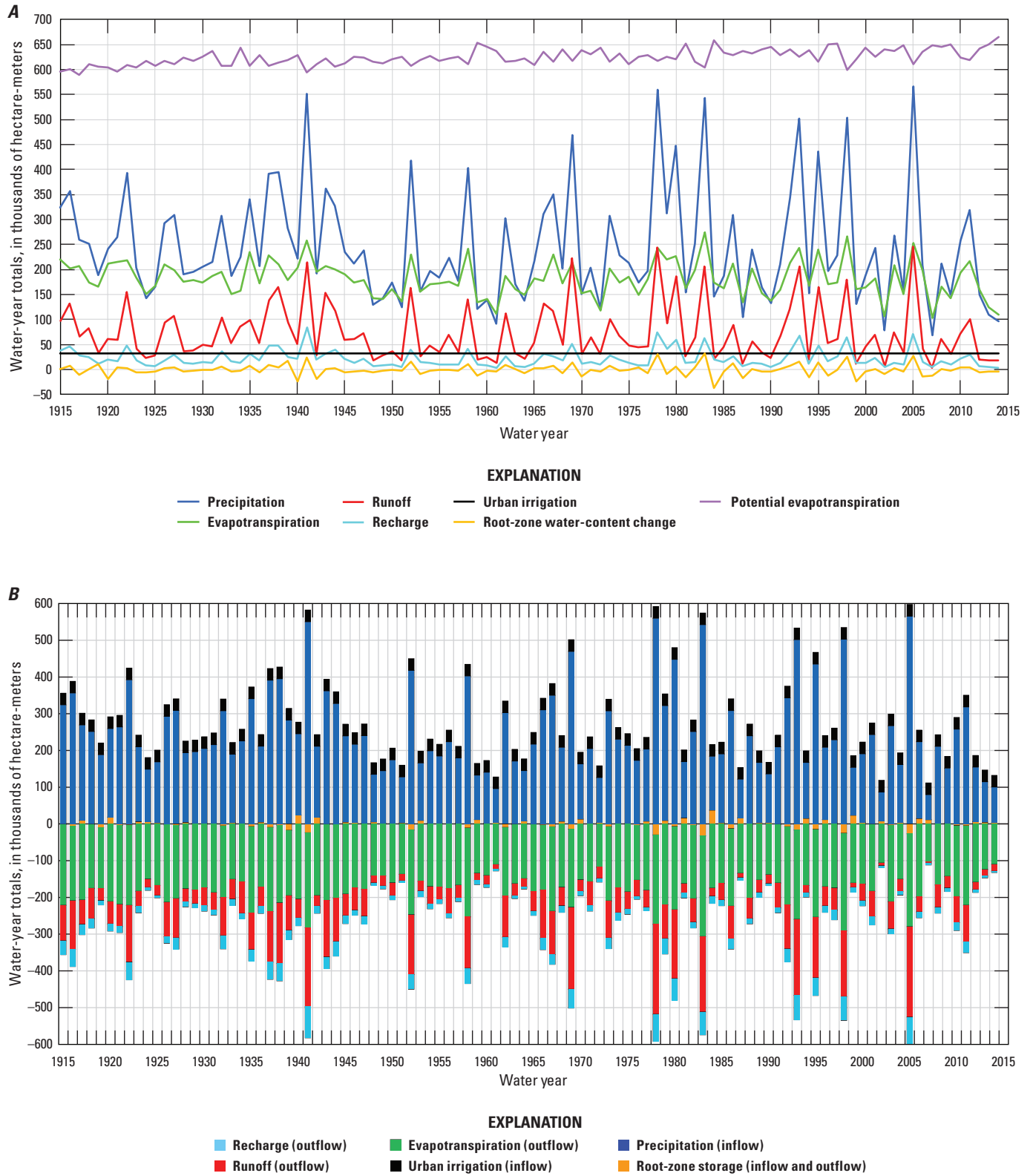
Base modified from U.S. Geological Survey and other State digital data, various scales  
 Universal Transverse Mercator, zone 11  
 North American Datum 1983



**EXPLANATION**

- |  |                     |   |
|--|---------------------|---|
| <b>Los Angeles Basin watershed model simulated 1915–2014 recharge, in millimeters per year</b> |                     | Los Angeles Basin watershed model area boundary |
| 0.0000–0.0010  | 10.0010–20.0000     | Water Replenishment District                    |
| 0.0011–1.0000  | 20.0010–50.0000     | Los Angeles recharge study area                 |
| 1.0010–2.0000  | 50.0010–100.0000    | Water bodies and flood-control areas            |
| 2.0010–5.0000  | 100.0010–200.0000   | Major rivers and streams                        |
| 5.0010–10.0000   | 200.0010–1,810.0000 | Minor rivers and streams                        |
|  |                     | Los Angeles groundwater basins                  |
|  |                     | County line                                     |

**Figure 37.** Spatially distributed average annual recharge simulated for water years 1915–2014 using the Los Angeles Basin watershed model (LABWM), California.



**Figure 38.** Annual simulation results for water years 1915–2014, Los Angeles Basin watershed model (LABWM), California: *A*, LABWM water-budget components; *B*, LABWM water-budget components as inflows and outflows; *C*, Los Angeles recharge-study area water-budget components; *D*, Los Angeles recharge-study area water-budget components as inflows and outflows; *E*, annual recharge for the LABWM domains; *F*, cumulative departure from mean annual recharge for the LABWM domains.



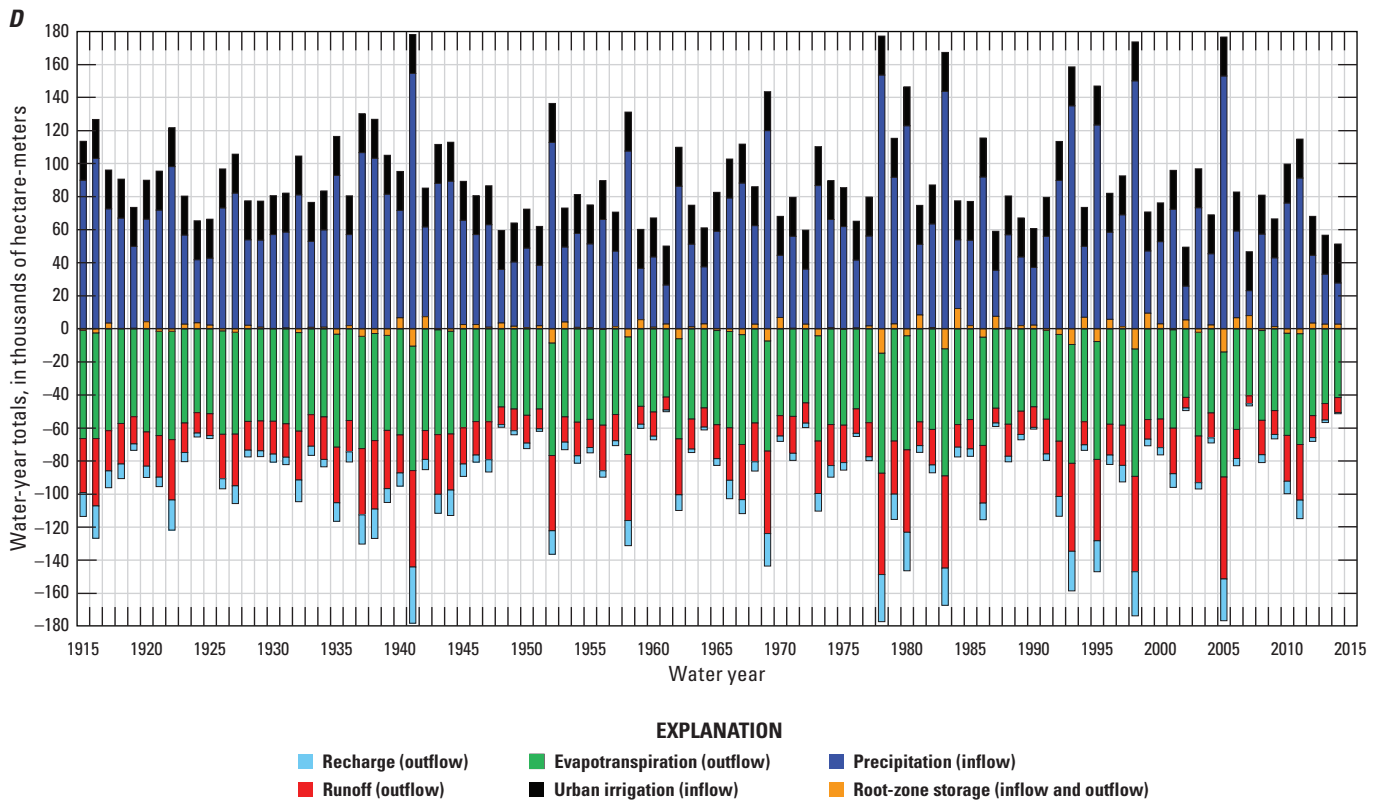
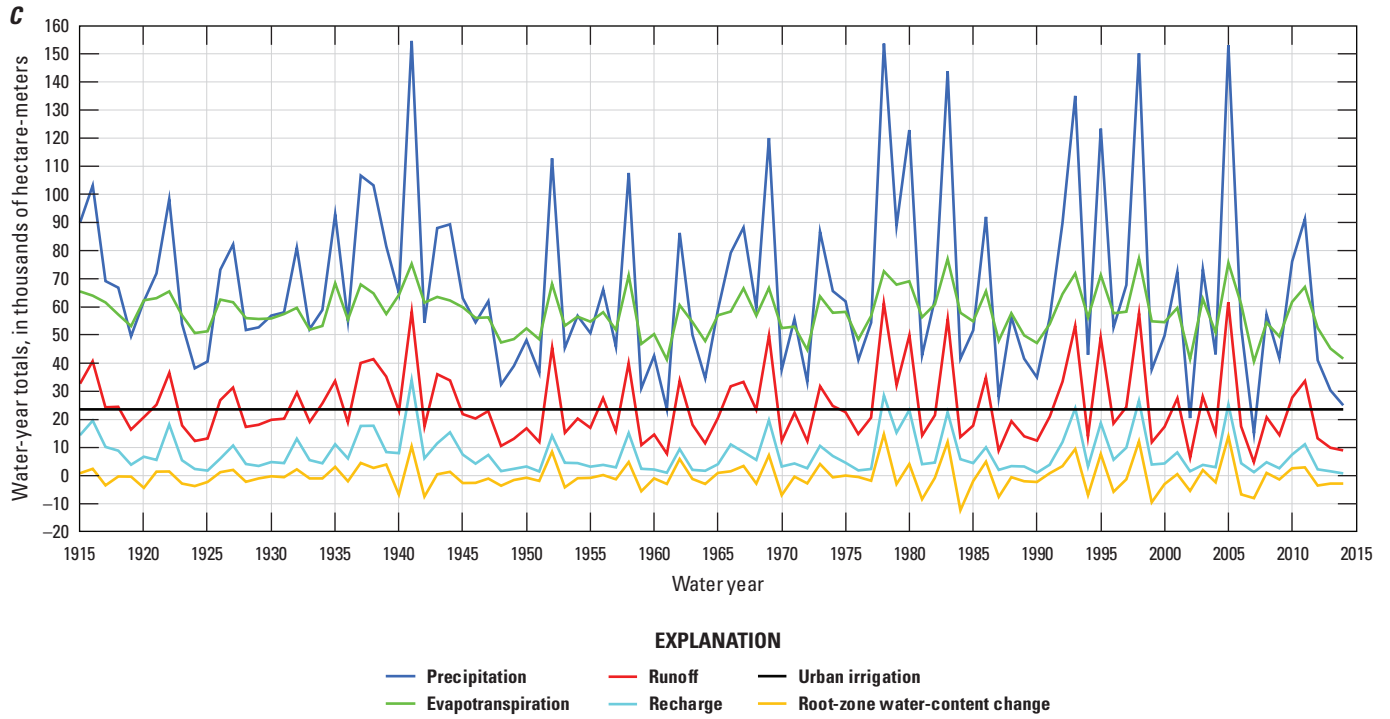


Figure 38. —Continued

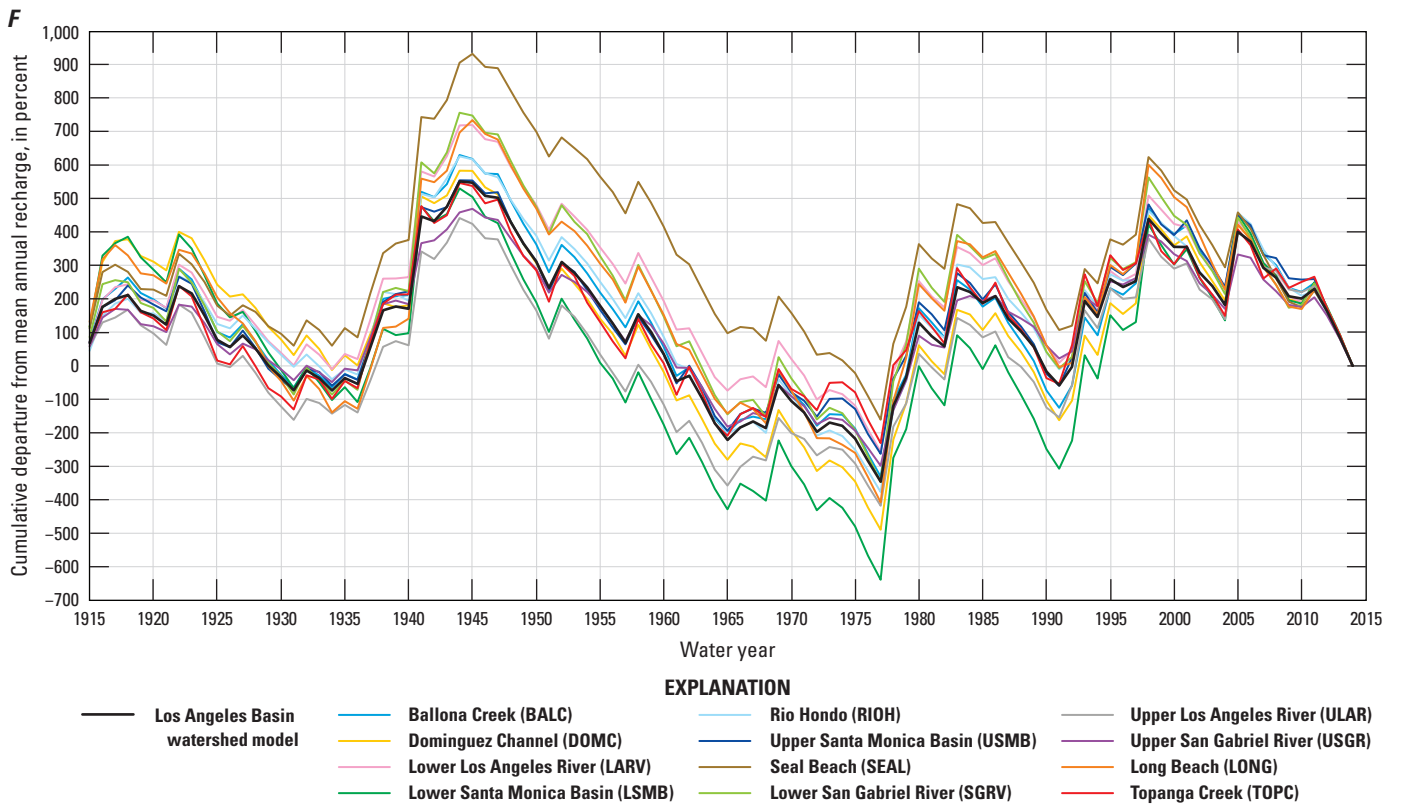
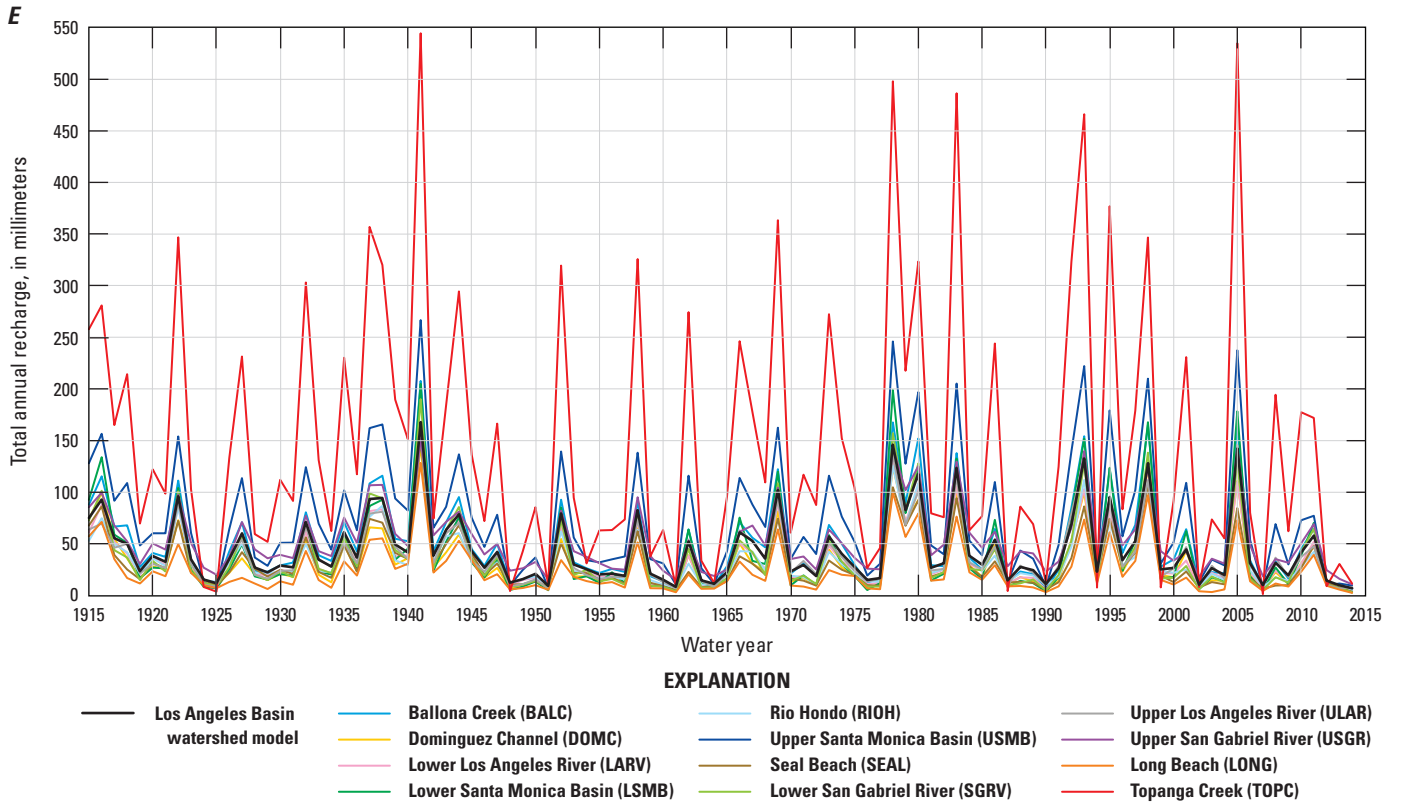


Figure 38. —Continued

1941, 246 mm for water year 1978, and 238 mm for water year 2005. During the driest years, recharge for all subdomains was less than 50 mm/yr. The cumulative departure from mean annual recharge indicated an initial period of lower than average recharge for all subdomains for water years 1918–36, followed by a period of higher than average recharge for water years 1937–45, and then a long period of generally lower than average recharge for water years 1946–77 (fig. 38F). Water years 1978–83 and 1992–98 were two periods of higher than average recharge for most years, whereas water years 1984–91 and 1998–2014 were two periods of lower than average recharge for most years. The Seal Beach (SEAL) subdomain had the greatest cumulative departure from mean annual precipitation at 932 percent ending with water year 1945, whereas the lower Santa Monica Basin (LSMB) subdomain had the least cumulative departure from mean annual precipitation at –639 percent ending with water year 1977. For the entire LABWM area, the maximum cumulative departure of 546 percent ended with water year 1944, and the minimum cumulative departure of –346 percent ended with water year 1977.

Annual results for water-budget components for the LAGSA and the eight groundwater basins in the LAGSA are provided in appendix 3. Annual variability in water-budget components for the groundwater basins was generally consistent with the results for the entire LAGSA in terms of year-to-year variability and wet or dry periods (figs. 38C, D). Comparison of results among the groundwater basins, however, also indicated some differences in annual variability in water-budget components. For example, the wettest year for Montebello Forebay was water year 1998 with 878 mm of precipitation, whereas the wettest year for Central Basin Pressure was water year 1978 with 768 mm of precipitation, and the wettest year for West Coast Basin was water year 2005 with 727 mm of precipitation (appendix tables 3–1, 3–2, 3–3). The driest water year for all three groundwater basins was 2007, with 60 mm for Montebello Forebay, 75 mm for Central Basin Pressure, and 77 mm for West Coast Basin. For the Hollywood groundwater basin, the wettest groundwater basin in terms of average annual precipitation, water year 2005 was the wettest at 942 mm of precipitation, and water year 2007 was the driest at 91 mm of precipitation (appendix table 3–7). For the Orange County groundwater basin, water year 1941 was the wettest at 748 mm of precipitation, and water year 2007 also was the driest at 72 mm of precipitation (appendix table 3–4). Results for simulated annual runoff were similar to results for precipitation, such that differences among groundwater basins in water years with the highest and lowest runoff were closely correlated to differences in precipitation. Results for direct recharge indicated that the water years with the highest and lowest direct recharge for all groundwater basins were consistent; the most direct recharge for all groundwater basins was in water year 1941, and the least direct recharge for all groundwater basins was in water year 2014.

## Comparison of Recharge for Wet and Dry Years

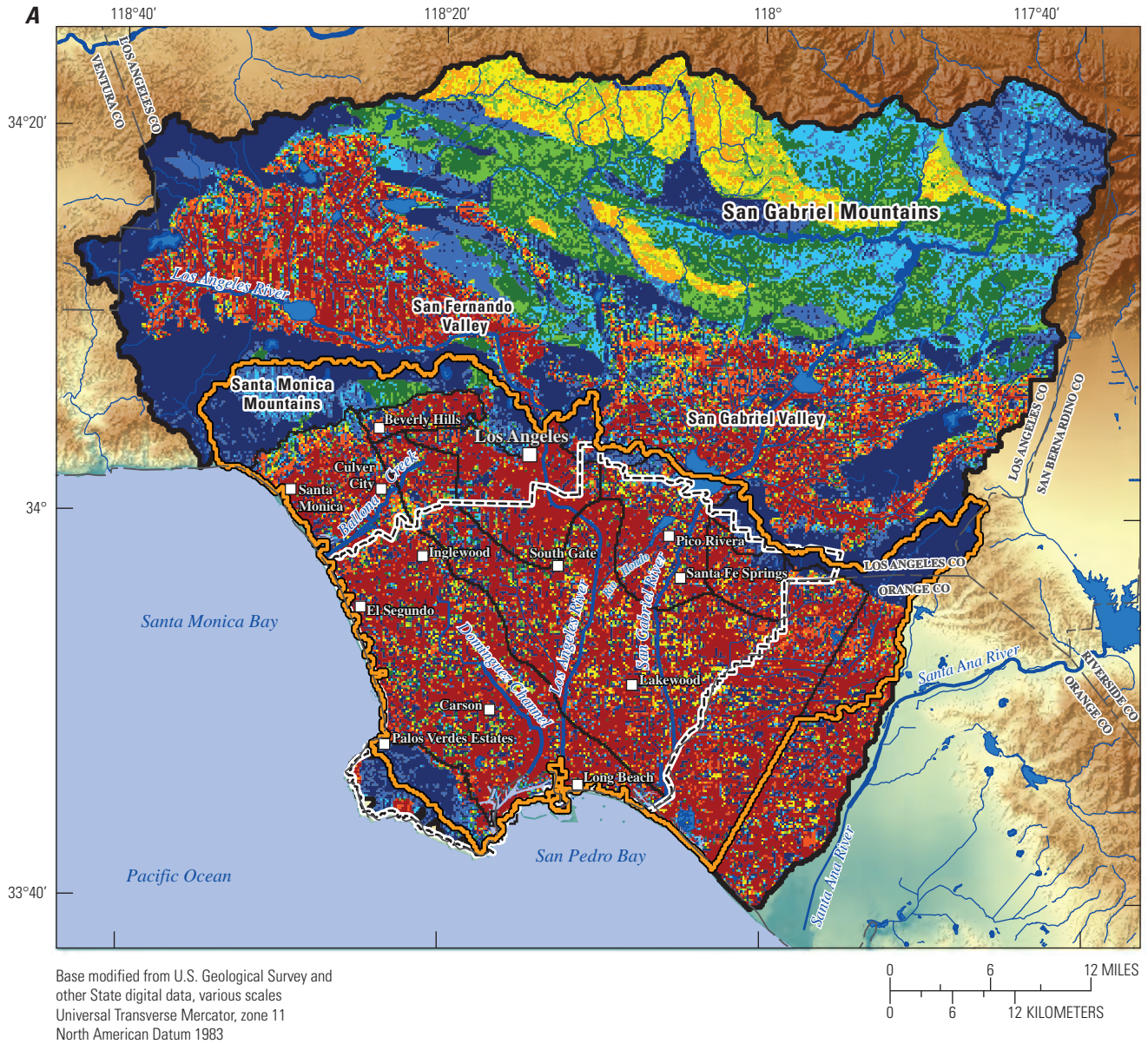
The spatial distribution of recharge for water year 2005, the wettest year in the last decade of the simulation period with basin-wide average recharge of 139 mm, was compared to results for water year 2007, the driest year in the simulation period with basin-wide average recharge of 6 mm (fig. 39). The maximum recharge for water year 2005 was 3,786 mm (fig. 39A), compared to a maximum recharge of only 297 mm for water year 2007 (fig. 39B). For the relatively wet water year (2005), recharge of 210 mm and greater was simulated for many upland areas underlain by bedrock with intermediate to high permeability. For upland areas with low permeability bedrock, such as along the northern boundary of the LABWM area in the San Gabriel Mountains, recharge was mostly limited to about 2–10 mm and was about the same as the recharge simulated for the dry year 2007. For the dry water year (2007), recharge for much of the San Gabriel Mountains was reduced from high values of more than 210 mm in water year 2005 to about 11–50 mm. Recharge for much of the Santa Monica Mountains was reduced from high values of more than 210 mm for wet water year (2005) to values of 10 mm and less. During the dry water year (2007), the increased recharge from urban irrigation was a larger component of overall recharge in the lowland areas compared to results for the wet water year (2005).

## Average Monthly Results

Average monthly results were calculated as basin-wide averages for the LABWM to analyze the seasonal distribution of selected water-budget components. The highest average monthly precipitation of 59,000 ha-m was during February, and the lowest average monthly precipitation of about zero was in July (fig. 40A). The maximum average monthly ET of about 28,000 ha-m was attained in April, and the maximum streamflow of about 24,000 ha-m was in February (fig. 40A). Average monthly recharge did not show a correlation to average monthly urban irrigation (fig. 40B), indicating that the timing of recharge was more dependent on precipitation than on urban irrigation. The maximum average monthly recharge of about 4,700 ha-m was during March the last month of the quarter that had the minimum urban irrigation rate of 750 ha-m.

The distribution of average monthly inflows and outflows shows the approximate water budget (changes in root-zone storage are excluded) and the relative magnitudes of the various water-budget components. Precipitation was the dominant inflow from October through May, but urban irrigation was the dominant inflow from June through September (fig. 40C). Streamflow was the dominant outflow from December through February, whereas ET was the dominant outflow from March through November. Streamflow discharge from the LABWM was zero for the months of May through August, but recharge was 1,000 ha-m or more for these months.



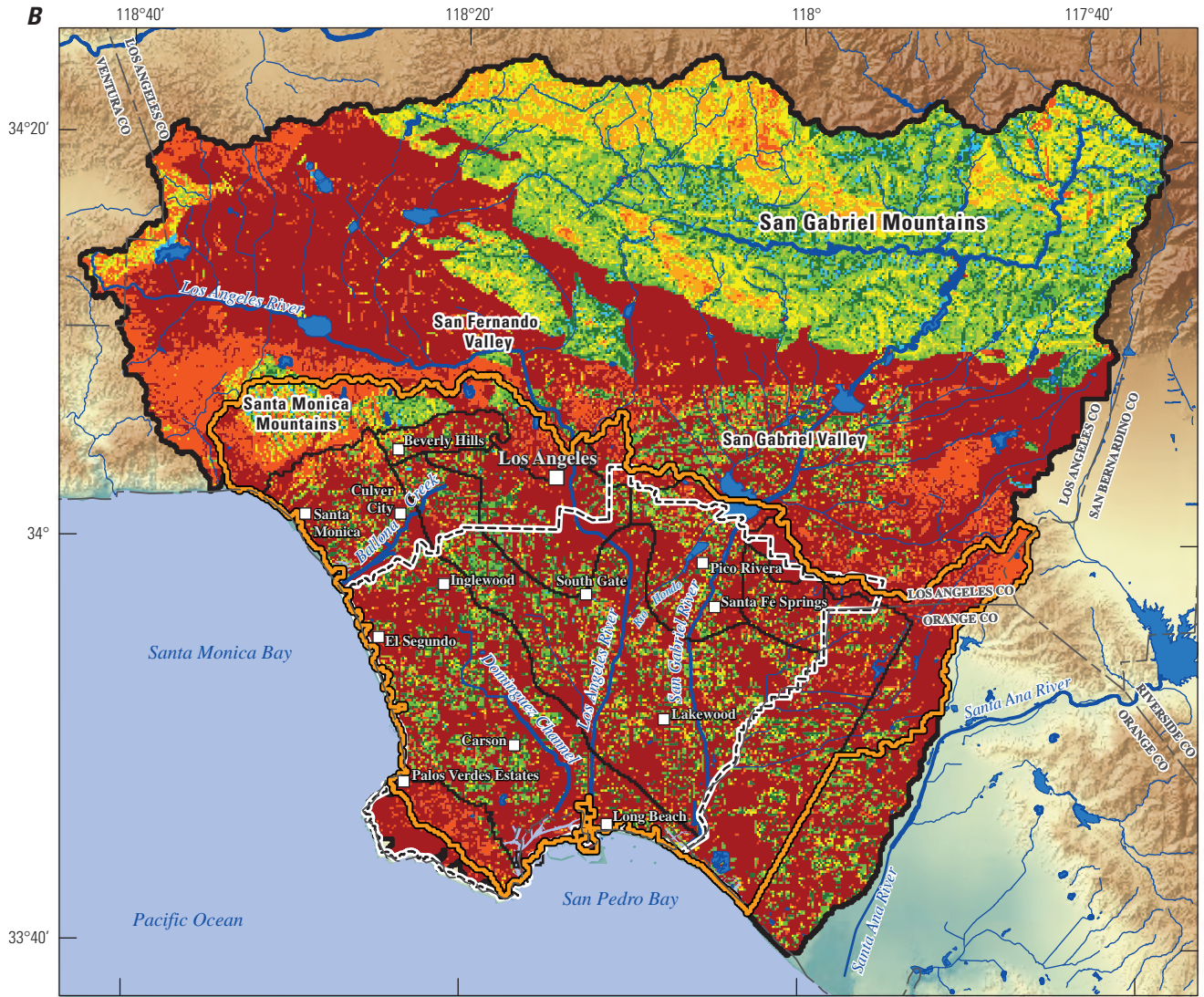


**EXPLANATION**

<b>Los Angeles Basin watershed model simulated water year 2005 recharge, in millimeters</b>		Los Angeles Basin watershed model area boundary
0.000	10.100–20.000	Water Replenishment District
0.001–1.000	20.100–50.000	Los Angeles recharge study area
1.100–2.000	50.100–100.000	Water bodies and flood-control areas
2.100–5.000	100.100–200.000	Major rivers and streams
5.100–10.000	200.100–3,800.000	Minor rivers and streams
		Los Angeles groundwater basins
		County line

**Figure 39.** Simulated annual recharge, Los Angeles basin watershed model (LABWM), California, for *A*, water year 2005; and *B*, water year 2007.





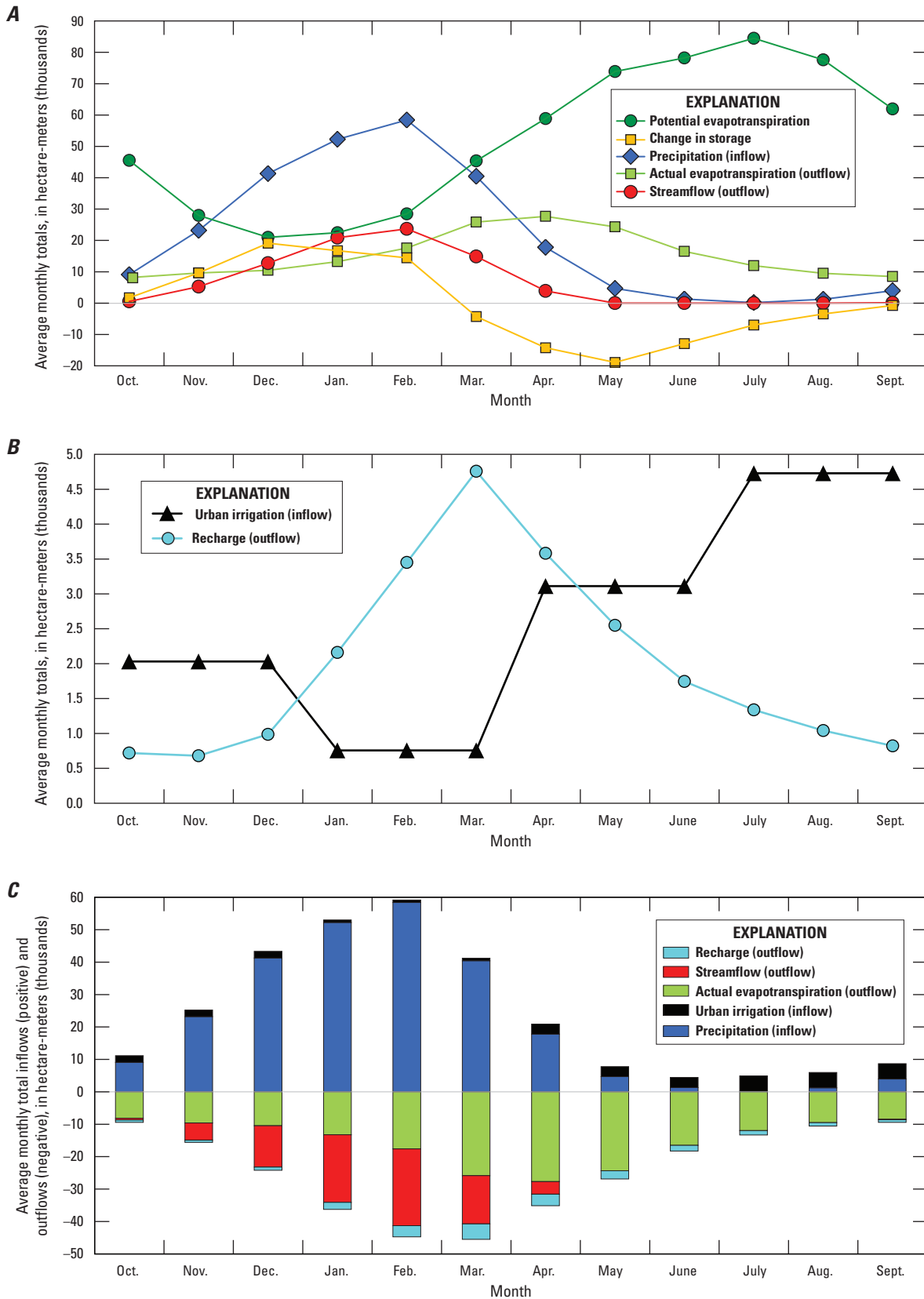
Base modified from U.S. Geological Survey and other State digital data, various scales  
 Universal Transverse Mercator, zone 11  
 North American Datum 1983



**EXPLANATION**

<b>Los Angeles Basin watershed model simulated water year 2007 recharge, in millimeters</b>		Los Angeles Basin watershed model area boundary
0.000	10.100–20.000	Water Replenishment District
0.001–1.000	20.100–50.000	Los Angeles recharge study area
1.100–2.000	50.100–100.000	Water bodies and flood-control areas
2.100–5.000	100.100–200.000	Major rivers and streams
5.100–10.000	200.100–297.000	Minor rivers and streams
		Los Angeles groundwater basins
		County line

Figure 39. —Continued



**Figure 40.** Average basin-wide monthly simulation results for water years 1915–2014, Los Angeles Basin watershed model (LABWM), California: *A*, water-budget components; *B*, urban irrigation and recharge; *C*, inflows and outflows.

## Recharge Estimates Developed for the LAGSA

The LABWM was primarily developed to estimate recharge for the LAGSA, which is the general area of interest for groundwater resources in the region. By using the LABWM simulation results, monthly and quarterly recharge were calculated for the areas of the LAGSA and six bordering drainages upstream from and tributary to the LAGSA that were included in the Los Angeles recharge-study area (fig. 41). The tributary drainages that were included in the Los Angeles recharge-study area contribute surface-water inflows, including overland runoff and seepage flow, to the LAGSA. Although the effect of the surface-water inflows on increasing direct recharge within the LAGSA is represented in the INFILv3 simulation, additional recharge from the tributary drainages could also contribute to the total recharge for the LAGSA as a mountain-front recharge component, and this was not directly represented by the INFILv3 simulation. In order to improve estimates of the total potential recharge to the LAGSA, the monthly and quarterly mountain-front recharge components along the LAGSA boundary were calculated and added to the direct recharge in the LAGSA. This method of developing estimates of total potential recharge for the LAGSA using the combined direct and mountain front recharge components is similar to methods used in Reichard and others (2006) for estimating total recharge.

Similar to the annual recharge results for the LABWM area, the total, direct, and mountain-front annual recharge results for the LAGSA indicated a high degree of year-to-year variability (fig. 42A). A maximum annual total recharge of 34,000 ha-m was simulated for water year 1941, of which the mountain-front recharge component contributed about 12,000 ha-m, and direct recharge in the LAGSA contributed about 22,000 ha-m. A minimum total annual recharge of 781 ha-m was simulated for water year 2014, of which mountain-front recharge was 194 ha-m. The 100-year average total potential recharge rate for the LAGSA was about 7,900 ha-m/yr, of which about 2,700 ha-m/yr was mountain-front recharge, and 5,200 ha-m/yr was direct recharge in the LAGSA.

To identify wet and dry periods in terms of multi-year averaged recharge estimates, the 5-year moving-average recharge was calculated for the LAGSA, the eight groundwater basins in the LAGSA, and the six bordering mountain-front areas that potentially contribute recharge to the LAGSA. The wettest 5-year period ended with water year 1941 and had an average of about 75 mm/yr of direct recharge for the LAGSA (fig. 42B). The 5-year periods ending with water year 1982 and 1999 also had higher than average direct recharge in the LAGSA of more than 50 mm/yr. The 5-year average recharge for all eight groundwater basins were similar; water years 1937–41 had the highest 5-year average recharge rate for all groundwater basins, and water years 1987–91 had the lowest 5-year average recharge rate for all but the Orange County groundwater basin, which

had the lowest 5-year average recharge rate for water years 1960–64. The Montebello Forebay Basin consistently had the highest 5-year average recharge, and the Orange County Basin consistently had the lowest 5-year average recharge. For all basins, the 5-year average recharge rate followed a pattern of high values for the 5-year periods ending with water years 1939–45, water years 1980–84, and water years 1995–2001. Similarly, all groundwater basins followed a pattern of low 5-year average recharge rates for periods ending with water years 1948–67, 1974–77, 1988–92, 2002–03, and 2010–14.

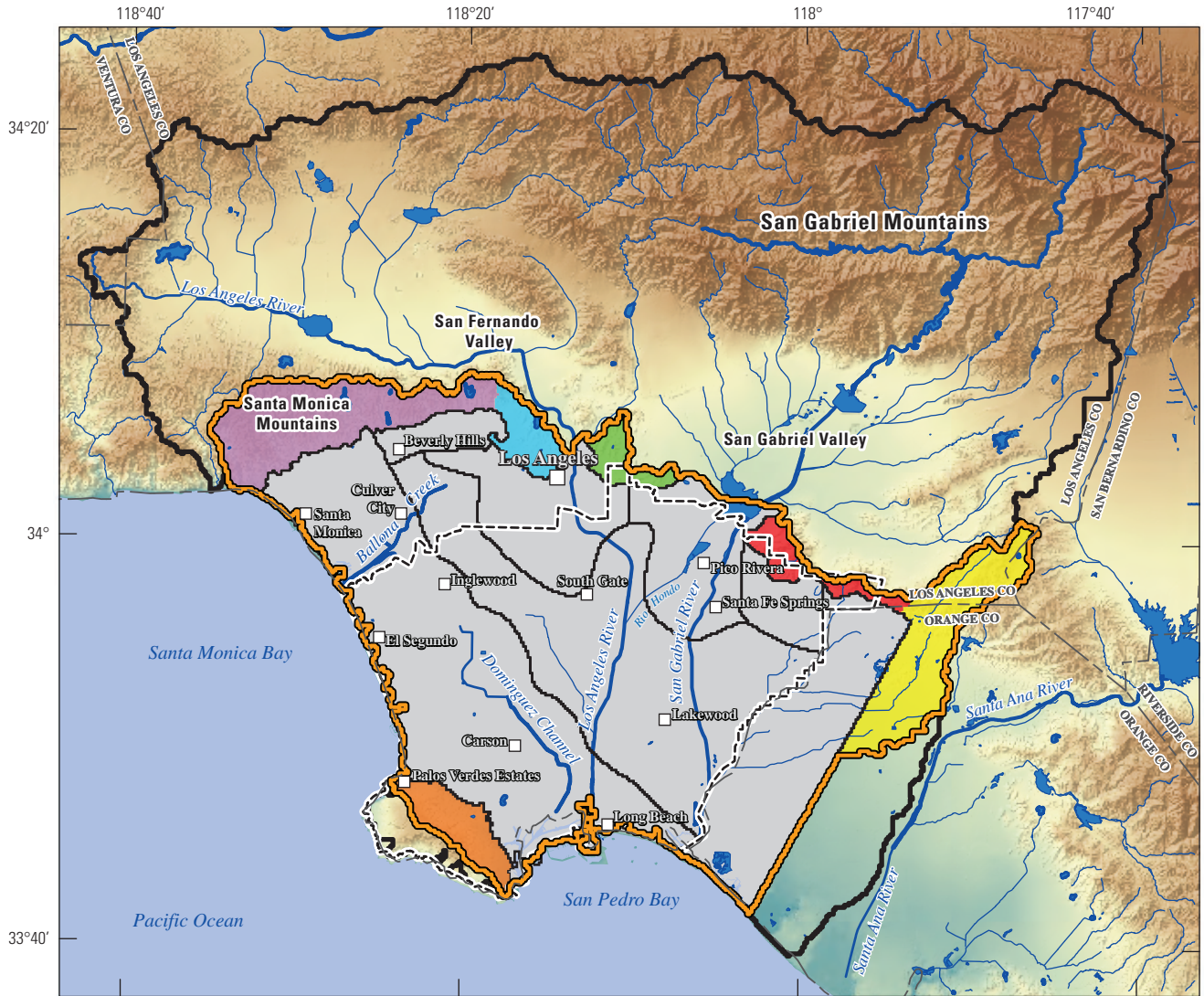
For most periods, the 5-year average recharge for all six of the tributary mountain-front areas bordering the LAGSA was greater than the direct recharge for the LAGSA (fig. 42C). The Palo Verdes Hills had less average recharge than the LAGSA for a few of the drier periods, such as water years 1927–31, 1949–51, 1957, and 1991. The Santa Monica Mountains had the highest 5-year average recharge for all water years except 1980, when the Puente Hills had a higher recharge rate. The 100-year average recharge was 94 mm/yr for the Santa Monica Mountains, 52 mm/yr for the Elysian Hills, 62 mm/yr for the Repetto Hills, 66 mm/yr for the Puente Hills, 52 mm/yr for the Brea and Fullerton Creeks, and 51 mm/yr for the Palo Verdes Hills, compared to a 100-year average recharge of 35 mm/yr for the LAGSA.

The average monthly recharge was highest during March for all six mountain-front areas contributing recharge to the LAGSA (fig. 42D). The Santa Monica Mountains and the Puente Hills peripheral drainages had the highest average monthly recharge rate at about 20 mm. From January through July, the recharge rate for all peripheral drainages exceeded the internal-area recharge rate for the LAGSA. From August through November, however, the internal-area recharge exceeded the recharge rate for five of the six upstream peripheral drainages because of increased recharge from urban irrigation in the internal area.

## Effect of Urban Irrigation on Recharge

Simulation results with and without urban irrigation were compared for the eight LABWM subdomains containing the area of the LAGSA and the mountain-front recharge areas in the Los Angeles recharge-study area (table 13). The comparison was done for simulated ET, change in root-zone water storage, recharge, and runoff. For the total area of the subdomains, the results showed a 51 percent increase in ET from urban irrigation, with 82 percent of the irrigation inflow contributing to ET (table 13). The Long Beach subdomain had the largest increase in ET from urban irrigation (62 percent), and the upper Santa Monica basin subdomain had the largest percentage of urban irrigation contributing to ET (69 percent). Urban irrigation resulted in a 247 percent decrease in the change in root-zone water storage for the total area of the eight subdomains, with a change in water storage of –211 ha-m/yr with urban irrigation compared to a change in water storage of –61 ha-m/yr without urban irrigation.





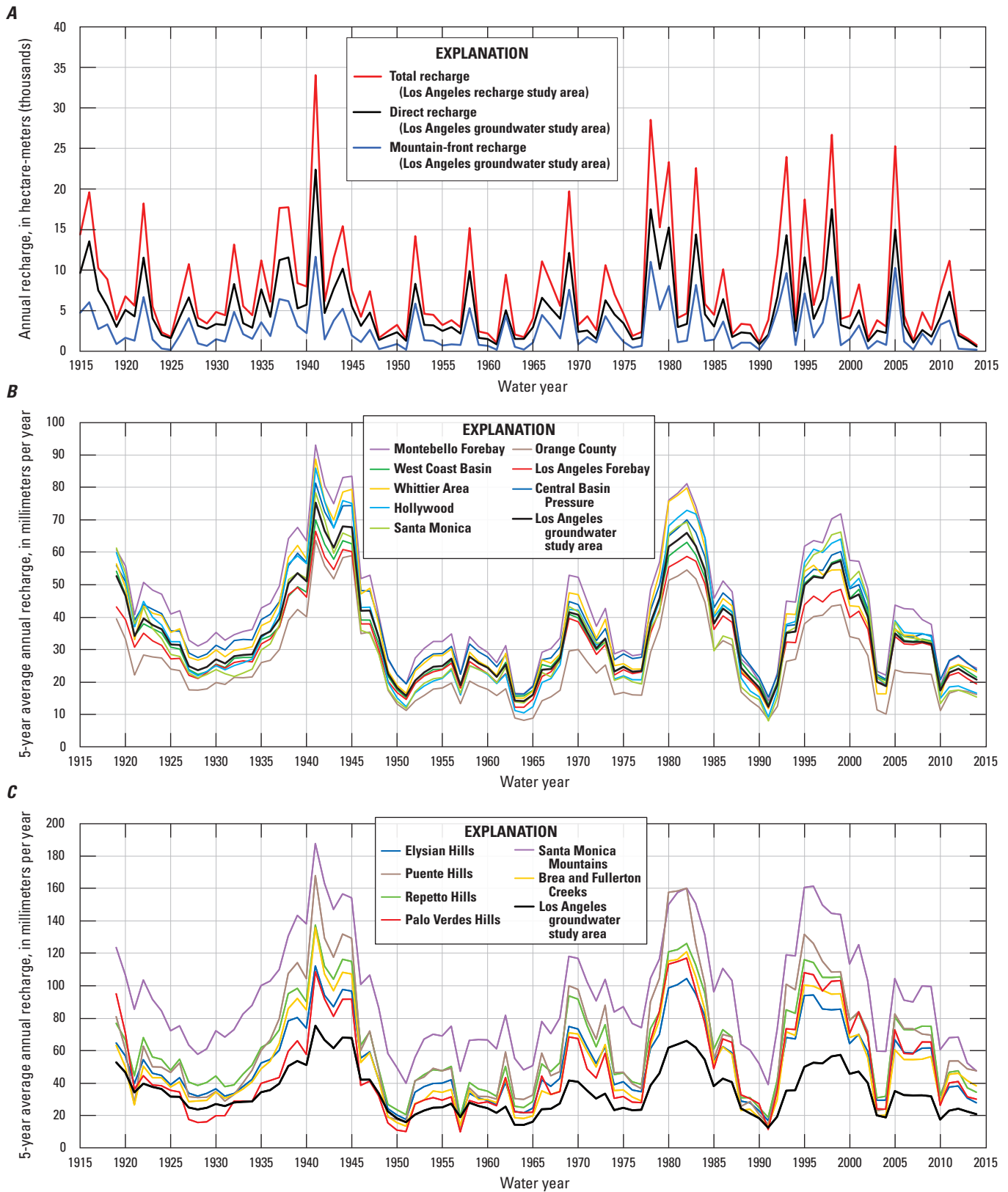
Base modified from U.S. Geological Survey and other State digital data, various scales  
 Universal Transverse Mercator, zone 11  
 North American Datum 1983



- EXPLANATION**
- Los Angeles Basin watershed model area boundary
  - Water Replenishment District
  - Los Angeles recharge study area
  - Water bodies and flood-control areas
  - Major rivers and streams
  - Minor rivers and streams
  - Los Angeles groundwater basins
  - County line
- 
- Recharge areas for the Los Angeles groundwater study area**
- Internal recharge area
- Contributing subdrainages**
- Brea and Fullerton Creeks
  - Elysian Hills
  - Palos Verdes Hills
  - Puente Hills
  - Repetto Hills
  - Santa Monica Mountains

Figure 41. Recharge areas for the Los Angeles groundwater study area, Los Angeles Basin watershed model (LABWM), California.





**Figure 42.** Annual and average monthly recharge simulated for the Los Angeles groundwater study area, Los Angeles Basin watershed model (LABWM), California: *A*, direct and mountain-front recharge components; *B*, 5-year average annual direct recharge for groundwater basins; *C*, 5-year average annual recharge for mountain-front areas; *D*, average monthly recharge rate.

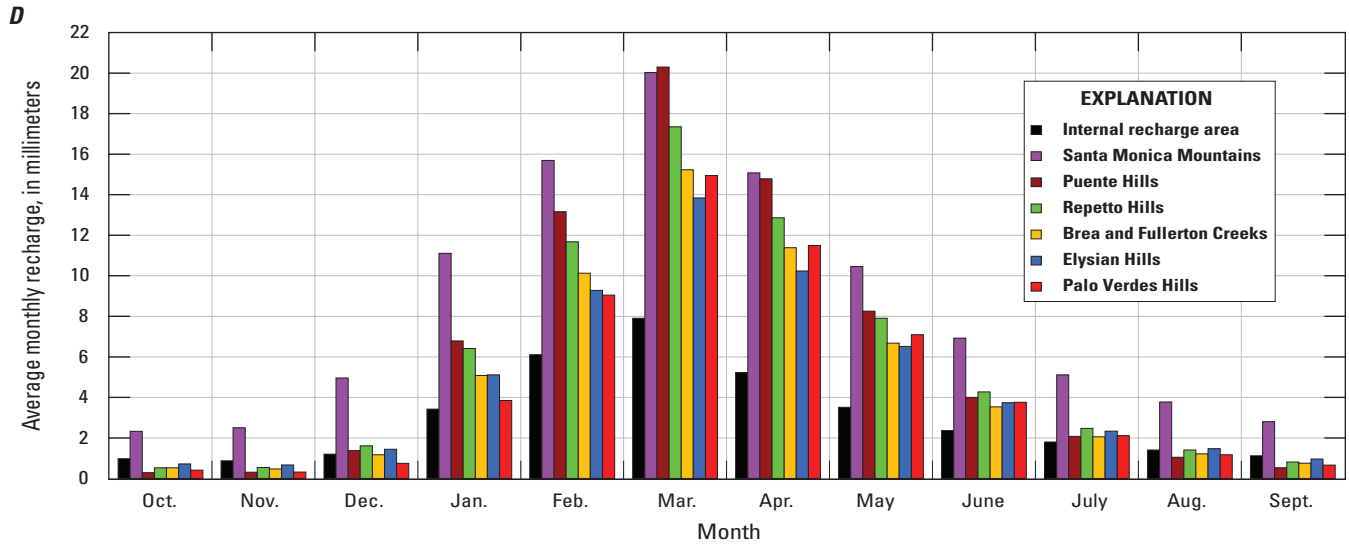


Figure 42. —Continued

**Table 13.** Comparison of evapotranspiration and change in root-zone water-storage simulation results with and without urban irrigation, water years 1915–2014, Los Angeles Basin watershed model (LABWM), California.

[ha-m/yr, hectare-meter per year; mm/yr, millimeter per year]

Model and subbasin areas	Units	Evapotranspiration				Change in storage						
		Urban irrigation	With urban irrigation	Without urban irrigation	Irrigated minus non-irrigated	Percentage increase from irrigation	Percentage of irrigation	With urban irrigation	Without urban irrigation	Irrigated minus non-irrigated	Percentage decrease from irrigation	Percentage of irrigation
Ballona Creek (BALC)	mm/yr ha-m/yr	135 4,576	336 11,359	225 7,629	110 3,730	49 49	82 82	-1 -42	0 -13	-1 -29	232 232	-1 -1
Dominguez Channel (DOMC)	mm/yr ha-m/yr	118 3,616	270 8,276	174 5,311	97 2,965	56 56	82 82	-1 -26	0 -10	-1 -16	163 163	0 0
Lower Los Angeles River (LARV)	mm/yr ha-m/yr	122 4,573	269 10,095	171 6,424	98 3,671	57 57	80 80	-1 -40	0 -14	-1 -27	192 192	-1 -1
Long Beach (LONG)	mm/yr ha-m/yr	120 218	273 496	168 306	105 190	62 62	87 87	-1 -1	0 0	-1 -1	327 327	0 0
Lower Santa Monica Basin (LSMB)	mm/yr ha-m/yr	144 1,371	346 3,300	223 2,126	123 1,174	55 55	86 86	-1 -7	0 -2	0 -5	219 219	0 0
Seal Beach (SEAL)	mm/yr ha-m/yr	139 2,978	309 6,623	196 4,207	113 2,416	57 57	81 81	-1 -24	0 -5	-1 -19	418 418	-1 -1
Lower San Gabriel River (SGRV)	mm/yr ha-m/yr	131 7,832	327 19,563	218 13,060	109 6,503	50 50	83 83	-1 -63	0 -15	-1 -48	315 315	-1 -1
Upper Santa Monica Basin (USMB)	mm/yr ha-m/yr	87 949	369 4,017	292 3,177	77 841	26 26	89 89	-1 -9	0 -3	-1 -6	248 248	-1 -1
Total area for eight subbasins	mm/yr ha-m/yr	127 26,112	310 63,729	206 42,240	105 21,490	51 51	82 82	-1 -211	0 -61	-1 -150	247 247	-1 -1

The comparison of recharge results for the eight subdomains indicated an approximate doubling of the average recharge rate for water years 1915–2014 when urban irrigation was included in the model, with an average recharge of 8,473 ha-m/yr including urban irrigation compared to an average recharge of 3,741 ha-m/yr without including urban irrigation (table 14). About 18 percent of urban irrigation contributed to recharge, varying from 12 percent for the upper Santa Monica basin subdomain to 20 percent for the lower Los Angeles River subdomain. For the total area of the eight subdomains, the irrigation-induced recharge provided an average return flow of 4,733 ha-m/yr. In contrast to recharge, the effect of urban irrigation on streamflow was slight; it increased only 48 ha-m/yr from urban irrigation for the total area of the eight subdomains, which was only 0.2 percent of urban irrigation.

Simulations with and without urban irrigation were compared to evaluate the effect of urban irrigation on the spatial distribution of ET, the change in root-zone water content, streamflow, and recharge in the Los Angeles recharge-study area. Results for simulated ET without urban irrigation indicated a large reduction in ET in the Los Angeles recharge-study area (fig. 43). Rates of ET showed maximum reductions of 321 to 412 mm where the most urban irrigation was used (fig. 43). The rate of ET was reduced more than 40 mm/yr in most of the Los Angeles recharge-study area.

Results for the change in root-zone storage using the simulation without urban irrigation indicated a drier root zone compared to results with urban irrigation (fig. 44). The areas where root-zone storage increased were greatly reduced without irrigation. The difference between irrigated and non-irrigated changes in the root-zone water content was the greatest for the more pervious locations that received surface-water run-on in addition to urban irrigation, with differences of 4 mm/yr and greater (fig. 44).

The difference between simulated streamflow with urban irrigation and simulated streamflow without it indicated an increase in runoff caused by urban irrigation (fig. 45). In the area of the Los Angeles recharge-study area, runoff from irrigation increased primarily in the upland areas of the peripheral drainages, where the soils are thinner and the storage capacity of the root zone is less than in the lowland areas with thick alluvium. In the lowland areas, urban irrigation caused only a very slight increase in runoff. The larger stream channels draining the upland areas, however, showed a greater increase in streamflow, and the maximum difference in streamflow was in the most upstream portions of the main channels.

The difference between simulated recharge with urban irrigation and simulated recharge without urban irrigation indicated increases in recharge in response to urban irrigation by as much as 201 to 452 mm/yr in areas with inflows from surface-water run-on (fig. 46).

Average monthly recharge simulated without including urban irrigation was compared to simulation results that included urban irrigation (figs. 42D, 47A, B, C). The monthly

distribution of recharge for the internal recharge area of the LAGSA and the six peripheral drainage areas contributing mountain-front recharge to the LAGSA were similar for the with and without irrigation results, but showed the expected overall decrease in recharge for all months when irrigation was not included (fig. 47B). The greatest absolute difference in the average monthly recharge showed the greatest absolute difference, about 5.25 mm, during March in the internal recharge area (fig. 47B). In general, the absolute increase in recharge for all areas was greatest during the months of January through May, indicating that the largest increases in recharge were caused by an increase in net infiltration from run-on with wet antecedent soil conditions when urban irrigation was included. The largest relative increases in average monthly recharge for irrigated minus non-irrigated simulation results were for the months of July through January (fig. 47C). The greater recharge in the summer months was caused directly by the net infiltration of urban irrigation. The greater recharge during December and January, however, was caused by the wet antecedent soils enhancing recharge from precipitation and run-on components. The largest relative increase in recharge from urban irrigation was in the internal recharge area of the LAGSA, which had increases of more than 1,000 percent for September through November and increases of more than 100 percent for all other months. In contrast, the relative increases in recharge for the Santa Monica Mountains contributing area was less than 10 percent for all months.

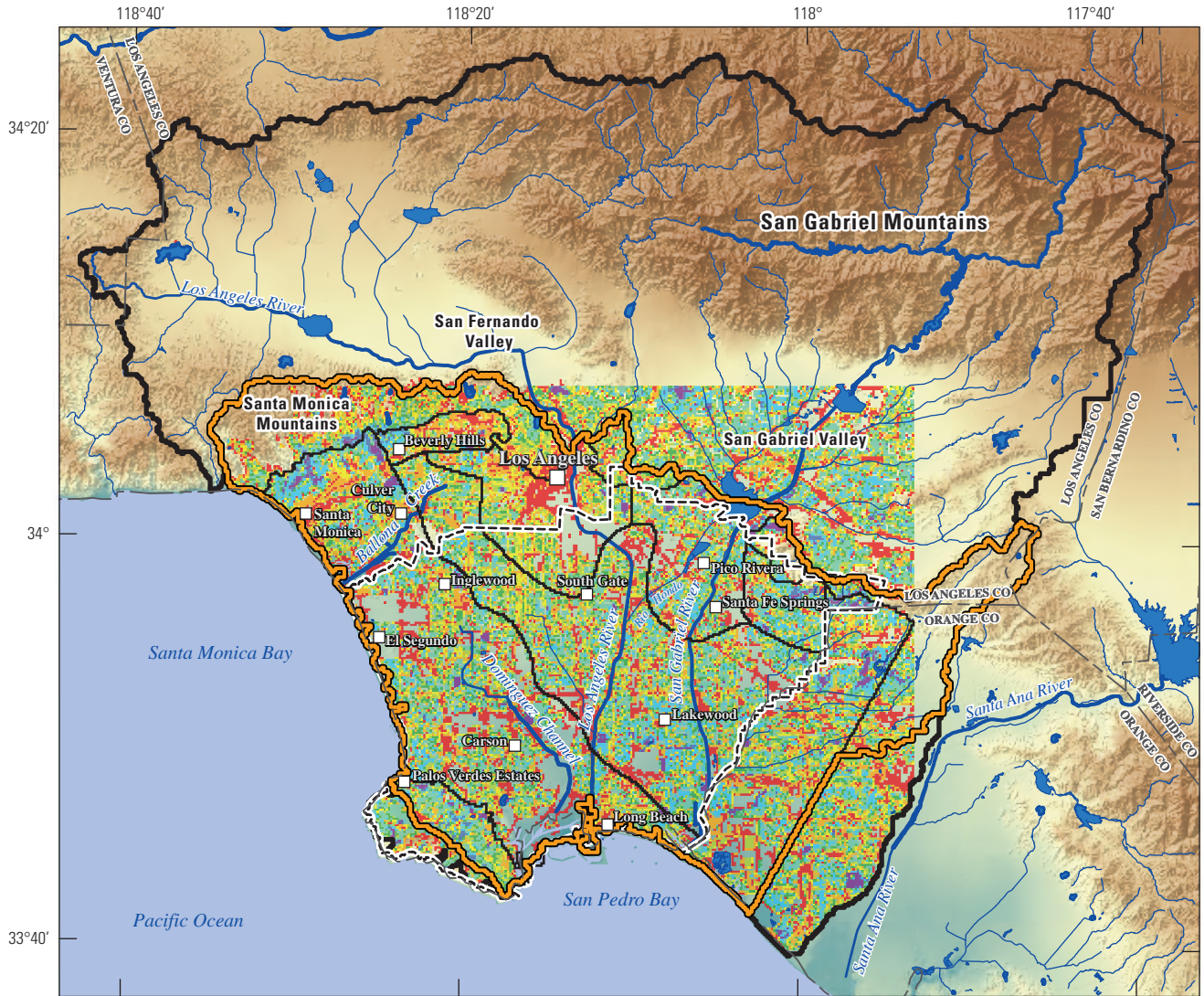
To qualitatively evaluate the sensitivity of simulated recharge and ET to the urban-irrigation estimates, simulation results for water years 1928–2011 for the eight subdomains overlying the Los Angeles recharge-study area (area contributing recharge to the LAGSA) were compared for a range of urban irrigation estimates that were calculated by a simple scaling of the urban irrigation rates using a linear multiplier. A multiplier of 1.0 was used to identify the results obtained for the calibrated model, referred to in this analysis as the baseline result. The minimum multiplier was 0 (no urban irrigation), and the maximum multiplier was 2.0 (for a doubling of the urban irrigation rates used in the baseline simulation). Simulated 1928–2011 average recharge and ET were the most affected by variations in urban irrigation. For most subdomains, recharge approximately doubled with a corresponding doubling of irrigation relative to the base case (fig. 48A), and ET increased by more than 25 percent for most subdomains (fig. 48B). The maximum recharge rate was simulated for the upper Santa Monica Basin (USMB) subdomain, where recharge of about 79 mm/yr in the baseline simulation increased to about 111 mm/yr when urban irrigation was doubled (fig. 48A). The Seal Beach (SEAL) subdomain had the greatest sensitivity of recharge to urban irrigation. Without urban irrigation (irrigation multiplier set to 0), Seal Beach (SEAL) had the lowest recharge rate at about 5 mm/yr. As the irrigation rate was increased to double the baseline rate, however, the Seal Beach (SEAL) recharge rate increased to about 80 mm/yr (about a 16-fold increase in recharge).



**Table 14.** Comparison of recharge and streamflow simulation results with and without urban irrigation for water years 1915–2014, Los Angeles Basin watershed model, California.

[ha-m/yr, hectare-meter per year; mm/yr, millimeter per year; —, no data]

Model and subbasin areas	Units	Recharge				Surface water discharge						
		Urban irrigation	With urban irrigation	Without urban irrigation	Irrigated minus non-irrigated	Percentage increase from irrigation	Percentage of irrigation	With urban irrigation	Without urban irrigation	Irrigated minus non-irrigated	Percentage increase from irrigation	Percentage of irrigation
Ballona Creek (BALC)	mm/yr	135	51	26	25	99	19	144	143	0.6	0.4	0.4
	ha-m/yr	4,576	1,723	868	855	99	19	4,864	4,845	19.3	0.4	0.4
Dominguez Channel (DOMC)	mm/yr	118	34	12	22	176	18	139	138	0.2	0.1	0.1
	ha-m/yr	3,616	1,039	376	662	176	18	4,244	4,239	4.8	0.1	0.1
Lower Los Angeles River (LARV)	mm/yr	122	38	13	25	192	20	812	812	0.2	0.0	0.2
	ha-m/yr	4,573	1,407	481	926	192	20	30,427	30,420	7.4	0.0	0.2
Long Beach (LONG)	mm/yr	120	25	9	16	180	13	123	123	0.0	0.0	0.0
	ha-m/yr	218	45	16	29	180	13	224	224	0.1	0.0	0.0
Lower Santa Monica Basin (LSMB)	mm/yr	144	43	22	21	95	14	84	84	0.4	0.5	0.3
	ha-m/yr	1,371	406	208	198	95	14	801	797	4.0	0.5	0.3
Seal Beach (SEAL)	mm/yr	139	32	5	27	559	19	100	100	0.0	0.0	0.0
	ha-m/yr	2,978	684	104	581	559	19	2,153	2,153	0.3	0.0	0.0
Lower San Gabriel River (SGRV)	mm/yr	131	39	16	23	140	18	479	479	0.1	0.0	0.1
	ha-m/yr	7,832	2,350	977	1,373	140	18	28,702	28,694	7.3	0.0	0.1
Upper Santa Monica Basin (USMB)	mm/yr	87	75	65	10	15	12	115	115	0.5	0.4	0.5
	ha-m/yr	949	820	710	109	15	12	1,252	1,247	5.1	0.4	0.5
Total area for eight subbasins	mm/yr	127	41	18	23	127	18	354	353	0.2	0.1	0.2
	ha-m/yr	26,112	8,473	3,741	4,733	127	18	72,667	72,618	48.2	0.1	0.2

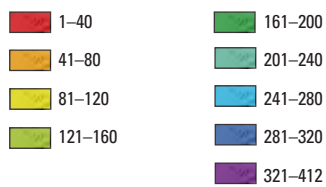


Base modified from U.S. Geological Survey and other State digital data, various scales  
 Universal Transverse Mercator, zone 11  
 North American Datum 1983



**EXPLANATION**

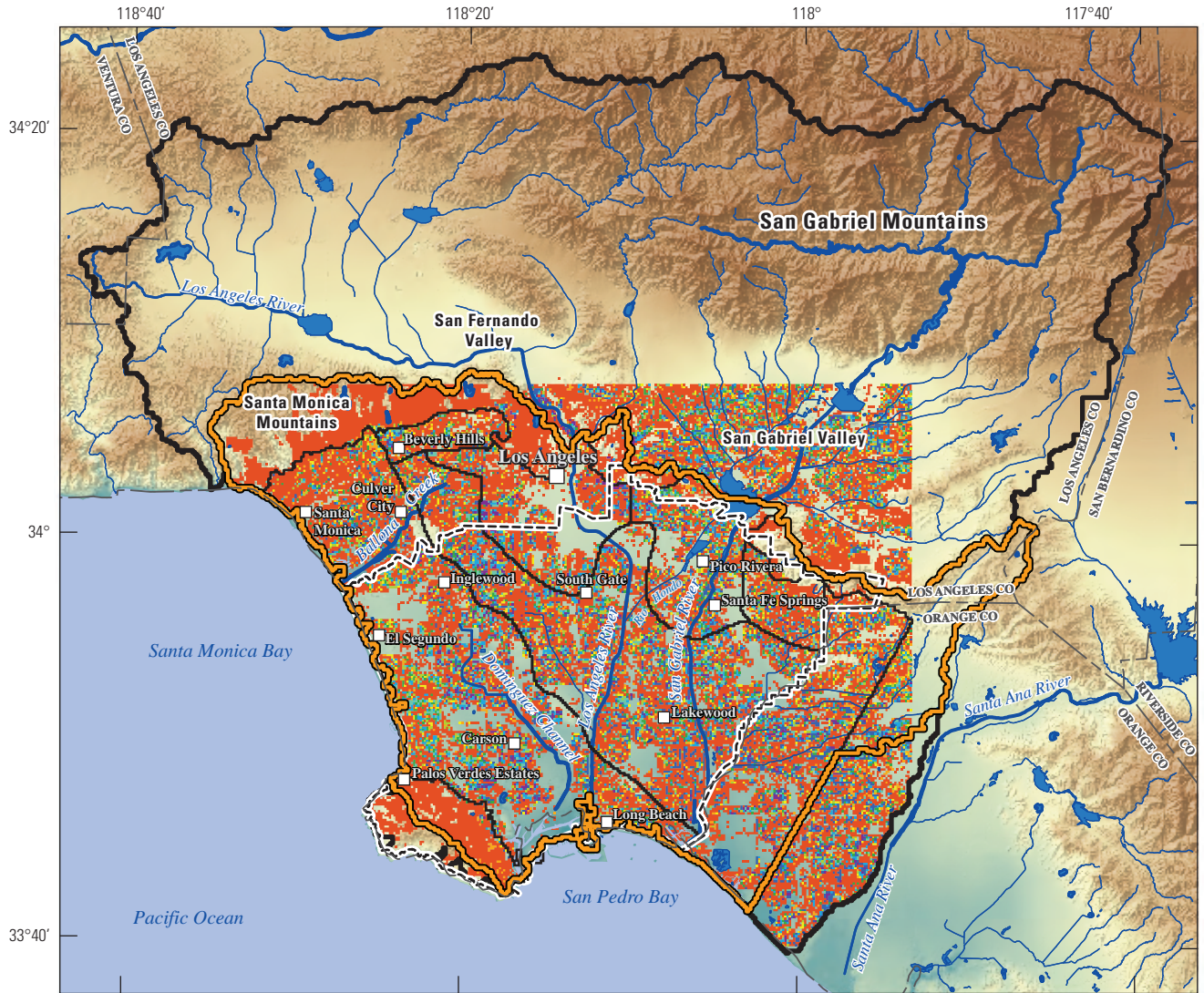
Simulated 1915–2014 evapotranspiration difference, irrigated minus non-irrigated, in millimeters per year



- Los Angeles Basin watershed model area boundary
- Water Replenishment District
- Los Angeles recharge study area
- Water bodies and flood-control areas
- Major rivers and streams
- Minor rivers and streams
- Los Angeles groundwater basins
- County line

**Figure 43.** Difference in simulation results, irrigated minus non-irrigated evapotranspiration for the Los Angeles recharge-study area, water years 1915–2014, Los Angeles Basin watershed model (LABWM), California.





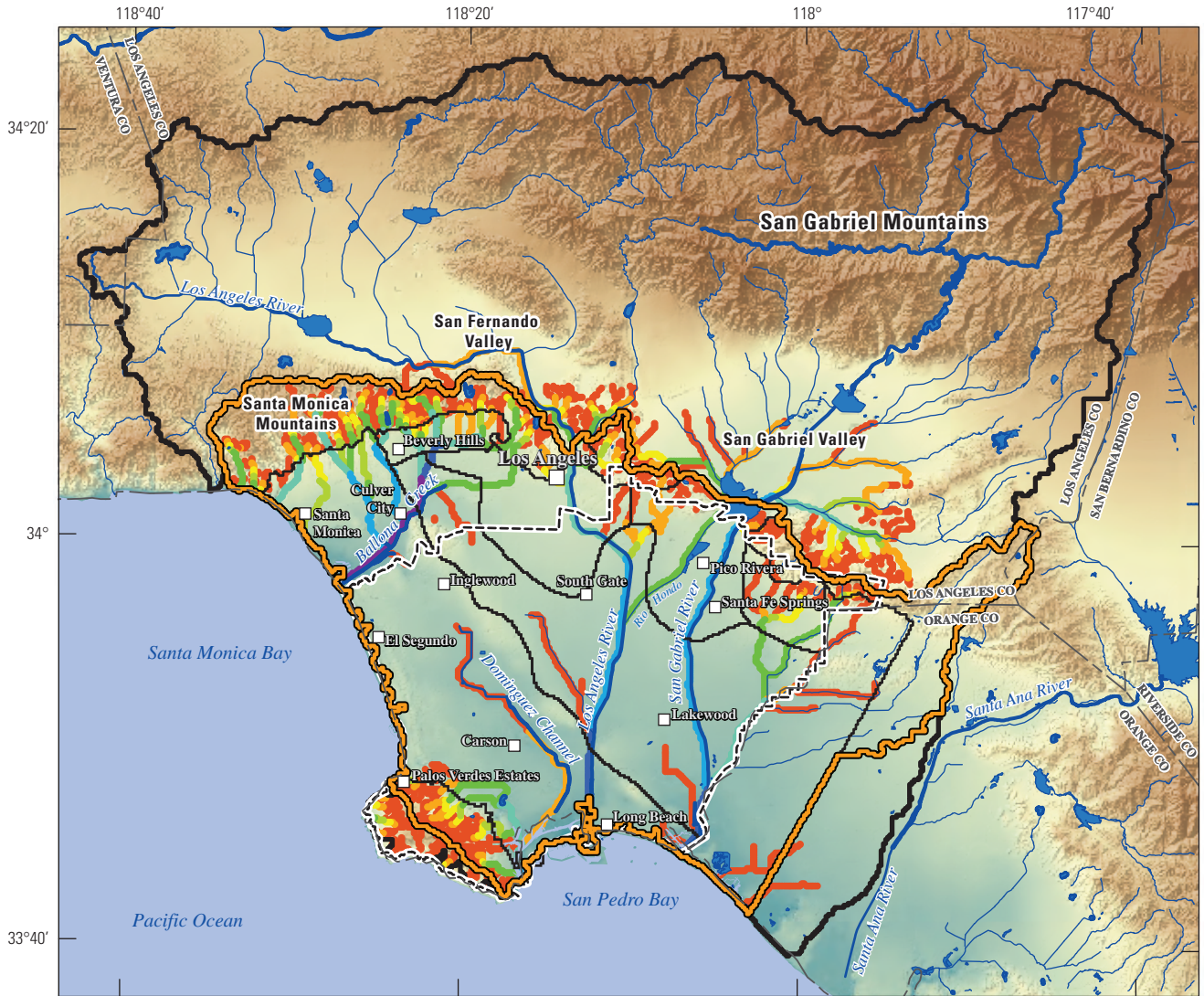
Base modified from U.S. Geological Survey and other State digital data, various scales  
 Universal Transverse Mercator, zone 11  
 North American Datum 1983

0 6 12 MILES  
 0 6 12 KILOMETERS

**EXPLANATION**

- |   |           |   |
|---|-----------|---|
| <b>Simulated 1915–2014 change in storage difference, irrigated minus non-irrigated, in millimeters per year</b> |           | Los Angeles Basin watershed model area boundary |
| 0.01–0.80   | 3.21–4.00 | Water Replenishment District                    |
| 0.81–1.60   | 4.01–4.80 | Los Angeles recharge study area                 |
| 1.61–2.40   | 4.81–5.60 | Water bodies and flood-control areas            |
| 2.41–3.20   | 5.61–6.40 | Major rivers and streams                        |
| 6.41–7.60   |           | Minor rivers and streams                        |
|   |           | Los Angeles groundwater basins                  |
|   |           | County line                                     |

**Figure 44.** Difference in simulation results, irrigated minus non-irrigated change in root-zone storage for the Los Angeles recharge-study area, water years 1915–2014, Los Angeles Basin watershed model, California.



Base modified from U.S. Geological Survey and other State digital data, various scales  
 Universal Transverse Mercator, zone 11  
 North American Datum 1983



**EXPLANATION**

- |  |        |         |   |
|--|--------|---------|---|
| <b>Simulated 1915–2014 streamflow difference, irrigated minus non-irrigated, in cubic-meters per day</b> |        |         | Los Angeles Basin watershed model area boundary |
| 1–5  | 16–20  | 101–150 | Water Replenishment District                    |
| 6–10   | 21–50  | 151–200 | Los Angeles recharge study area                 |
| 11–15  | 51–100 | 201–543 | Water bodies and flood-control areas            |
|  |        |         | Major rivers and streams                        |
|  |        |         | Minor rivers and streams                        |
|  |        |         | Los Angeles groundwater basins                  |
|  |        |         | County line                                     |

**Figure 45.** Percentage difference for irrigated minus non-irrigated simulation simulated runoff for the Los Angeles recharge-study area, water years 1915–2014, Los Angeles Basin watershed model (LABWM), California.





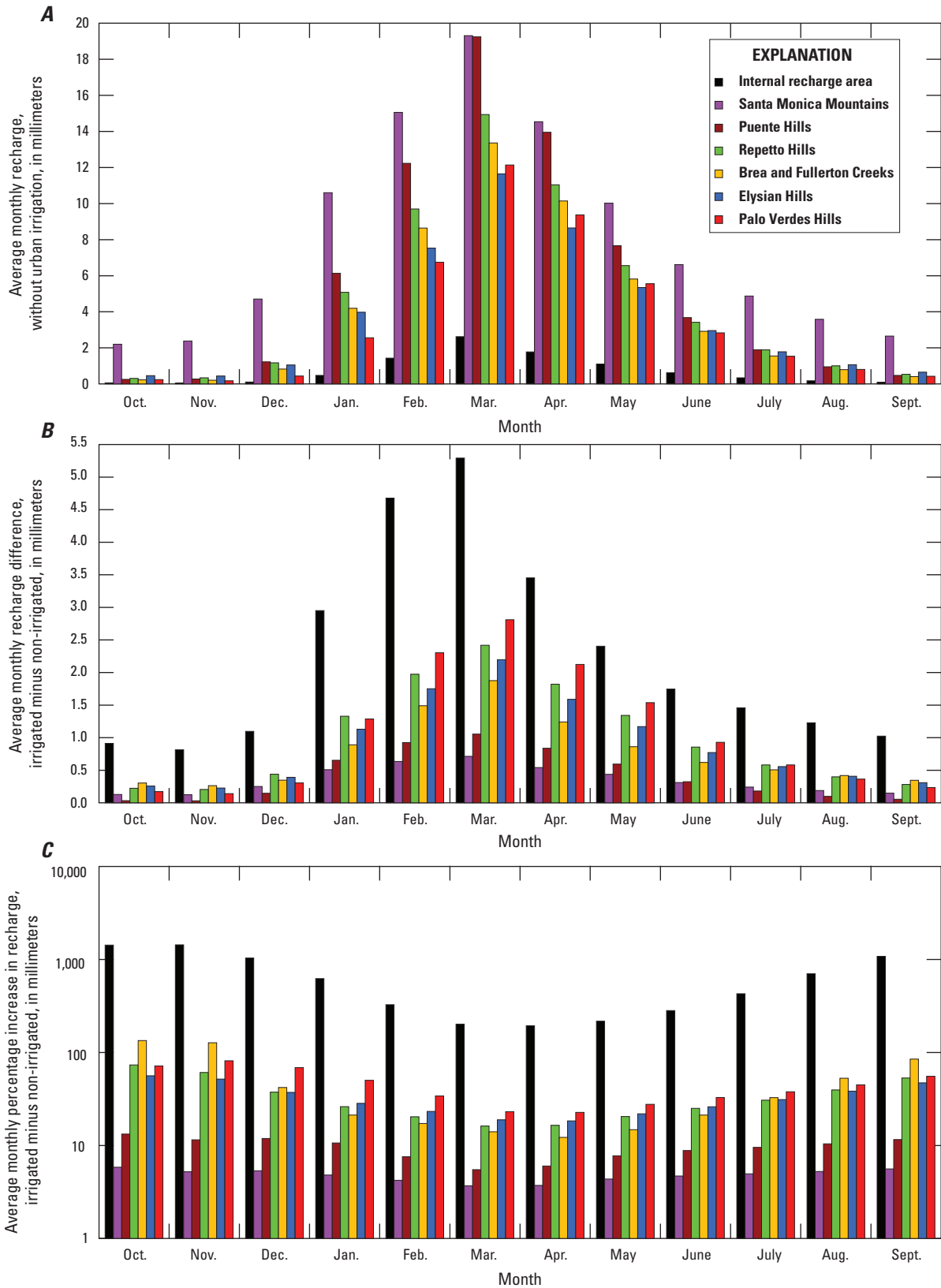
Base modified from U.S. Geological Survey and other State digital data, various scales  
 Universal Transverse Mercator, zone 11  
 North American Datum 1983



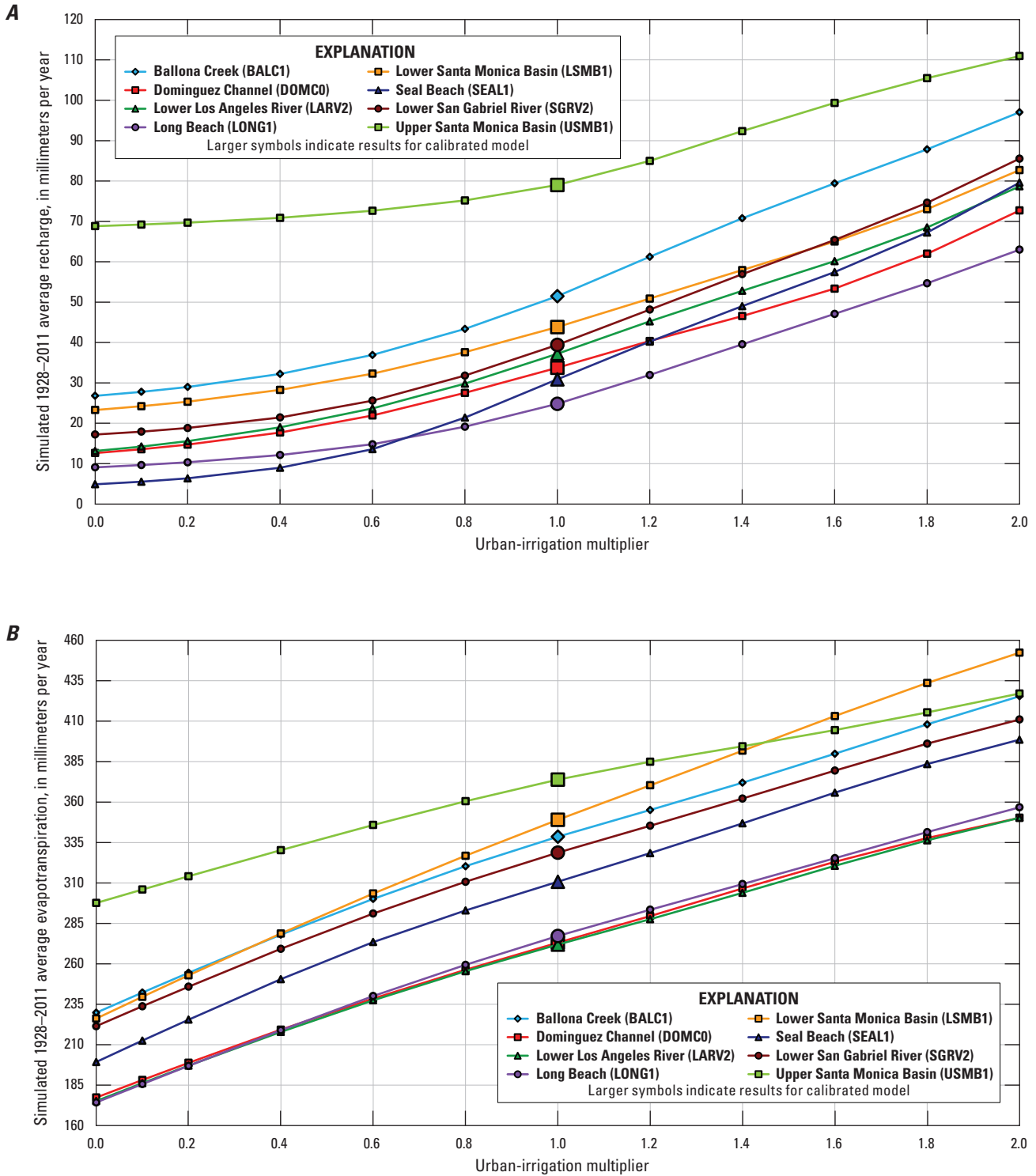
**EXPLANATION**

- |  |   |
|--|---|
| <b>Simulated 1915–2014 recharge difference, irrigated minus non-irrigated, in millimeters per year</b> | Los Angeles Basin watershed model area boundary |
| 0.01–1.00  | Water Replenishment District                    |
| 1.10–2.00  | Los Angeles recharge study area                 |
| 2.10–5.00  | Water bodies and flood-control areas            |
| 5.10–10.00   | Major rivers and streams                        |
| 10.10–20.00  | Minor rivers and streams                        |
| 20.10–50.00  | Los Angeles groundwater basins                  |
| 50.10–100.00   | County line                                     |
| 100.10–200.00  |   |
| 200.10–452.00  |   |

**Figure 46.** Difference in results, irrigated minus non-irrigated simulated recharge for the Los Angeles recharge-study area, water years 1914–2015, Los Angeles Basin watershed model (LABWM), California.



**Figure 47.** Comparison of average monthly simulated recharge, Los Angeles Basin watershed model (LABWM), California: *A*, average monthly recharge without irrigation; *B*, average monthly difference in recharge with and without urban irrigation; *C*, average monthly percentage increase in recharge with irrigation.



**Figure 48.** Comparison of simulation results for subdomains by using a range of urban irrigation estimates, Los Angeles Basin watershed model (LABWM), California: *A*, average 1928–2011 recharge; *B*, average 1928–2011 evapotranspiration.

The upper Santa Monica Basin (USMB) subdomain had the highest ET rate for urban-irrigation multipliers of 1.4 and less (fig. 48B). For multipliers of 1.6 and greater, the LSMB subdomain had the highest ET rate, which reached a maximum of 452 mm/yr with a multiplier of 2.0. In contrast to the results obtained for recharge, simulated ET was similar for the Dominguez Channel (DOMC), Long Beach (LONG), and lower Los Angeles River (LARV) subdomains over the entire range of urban-irrigation multipliers.

For all eight subdomains, the percentage of urban irrigation contributing to recharge increased as urban irrigation increased, whereas the percentage of irrigation contributing to ET decreased (fig. 49). At a multiplier of 0.1, urban irrigation varied between 8 and 14 mm/yr for the eight subdomains, contributing about 4 to 9 percent to recharge (fig. 49A) and 91 to 95 percent to ET (fig. 49B). At a multiplier of 2.0, urban irrigation varied from about 175 to 289 mm/yr, contributing 20 to 27 percent of the irrigated water to recharge (fig. 49A) and 72 to 78 percent to ET (fig. 49B). For all ranges and all subdomains, most of the urban irrigation was returned to the atmosphere by ET. Runoff and the average root-zone water content were also affected by variations in urban irrigation estimates; however, the relative changes to these components of the water balance were small compared to recharge and ET. At an urban-irrigation multiplier of 2.0, simulated runoff increased by less than 2 percent for all subdomains.

## Comparison with Previous Recharge Estimates

The recharge estimates developed by using the LABWM were compared with recharge estimates developed previously by Reichard and others (2003) for water years 1971–2000. By using the method applied in developing recharge estimates for the LAGSA, the total recharge estimated for the groundwater model defined in Reichard and others (2003) included both a direct-recharge component for the area of the groundwater model and also a mountain-front recharge component from the tributary upland areas bordering the model domain (fig. 50). For this analysis, the mountain-front recharge component included seven tributary upland areas bordering the model area. In addition to the recharge comparison, the LABWM spatially interpolated precipitation was compared with precipitation values used in Reichard and others (2003) to develop the transient recharge estimates.

The comparison between annual precipitation estimated with the LABWM and annual precipitation used in Reichard and others (2003) showed agreement between the annual and long-term average precipitation used to estimate recharge in both studies (fig. 51A). The greatest differences in precipitation estimates were for water years 1975, 1984, and 1992. Agreement was good for most wetter than average water years, such as 1978, 1983, and 1998. The long-term average

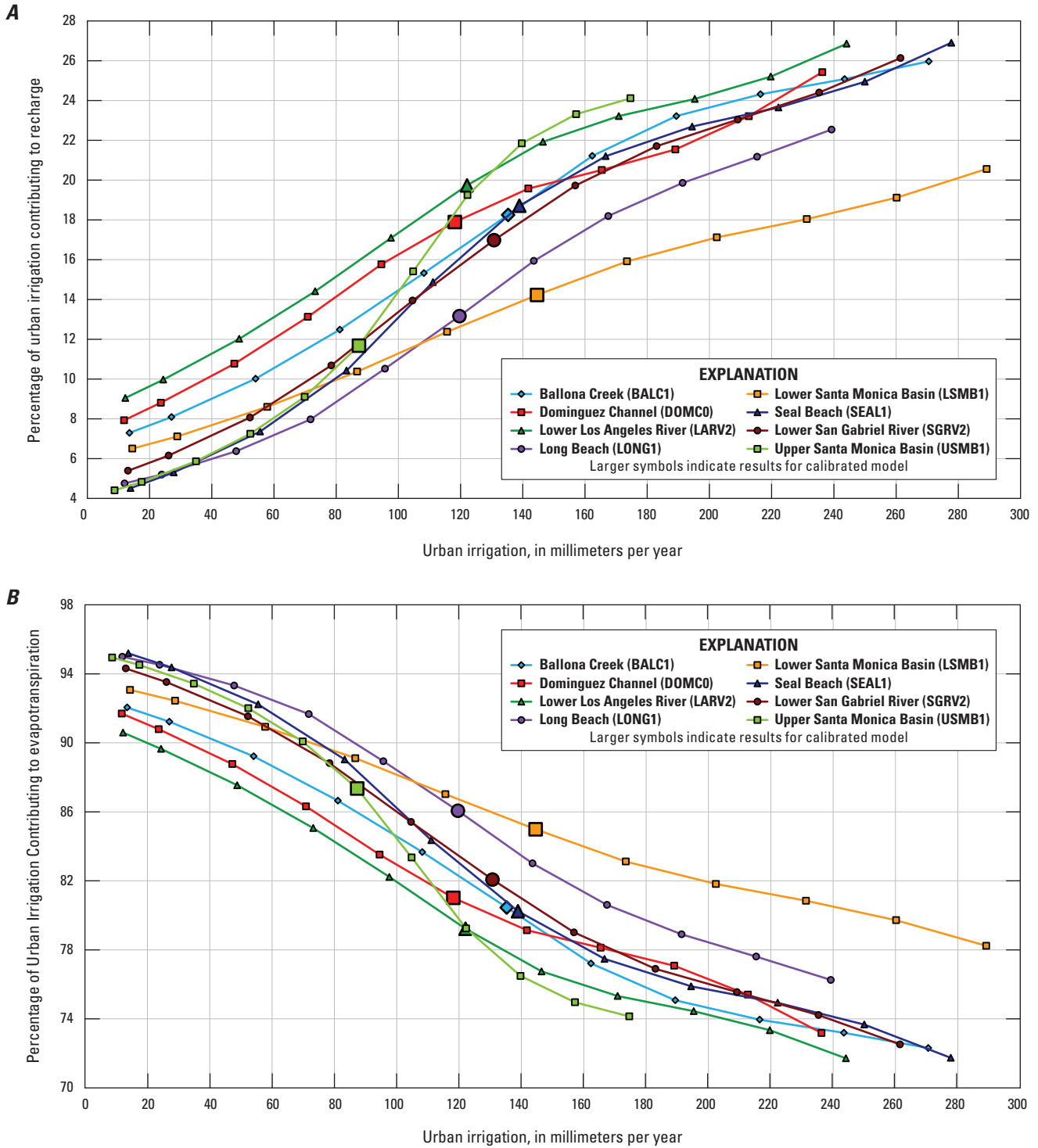
for water years 1971–2000 applied by Reichard and others (2003) was 391 mm/yr, which is comparable to the long-term average of 389 mm/yr estimated by the LABWM for the same period.

The LABWM simulated 30-year-average recharge of 7,975 ha-m/yr was in close agreement with the average of 8,321 ha-m/yr obtained by Reichard and others (2003; fig. 51B). The comparison of annual recharge, however, indicated a greater degree of annual variability in recharge estimated by the LABWM relative to the estimates obtained by Reichard and others (2003). For water years 1971–2000, annual recharge greater than 21,000 ha-m was simulated for water years 1978 and 1998, whereas annual recharge of 10,300 was estimated by Reichard and others (2003) for the same years. For most water years, including years with average-to-below-average precipitation, recharge simulated by the LABWM was less than that estimated by Reichard and others (2003). It should be noted that the estimates in Reichard and others (2003) were developed as the boundary condition for a calibrated groundwater-flow model and, therefore, indirectly accounted for the damping effect of the deeper unsaturated zone in terms of reducing year-to-year variability in recharge (this damping effect was not accounted for by the LABWM). The temporal pattern of annual recharge was generally similar for the two recharge estimates, with water years 1978–80, 1983, 1993, 1995, and 1998 all indicating greater than average recharge.

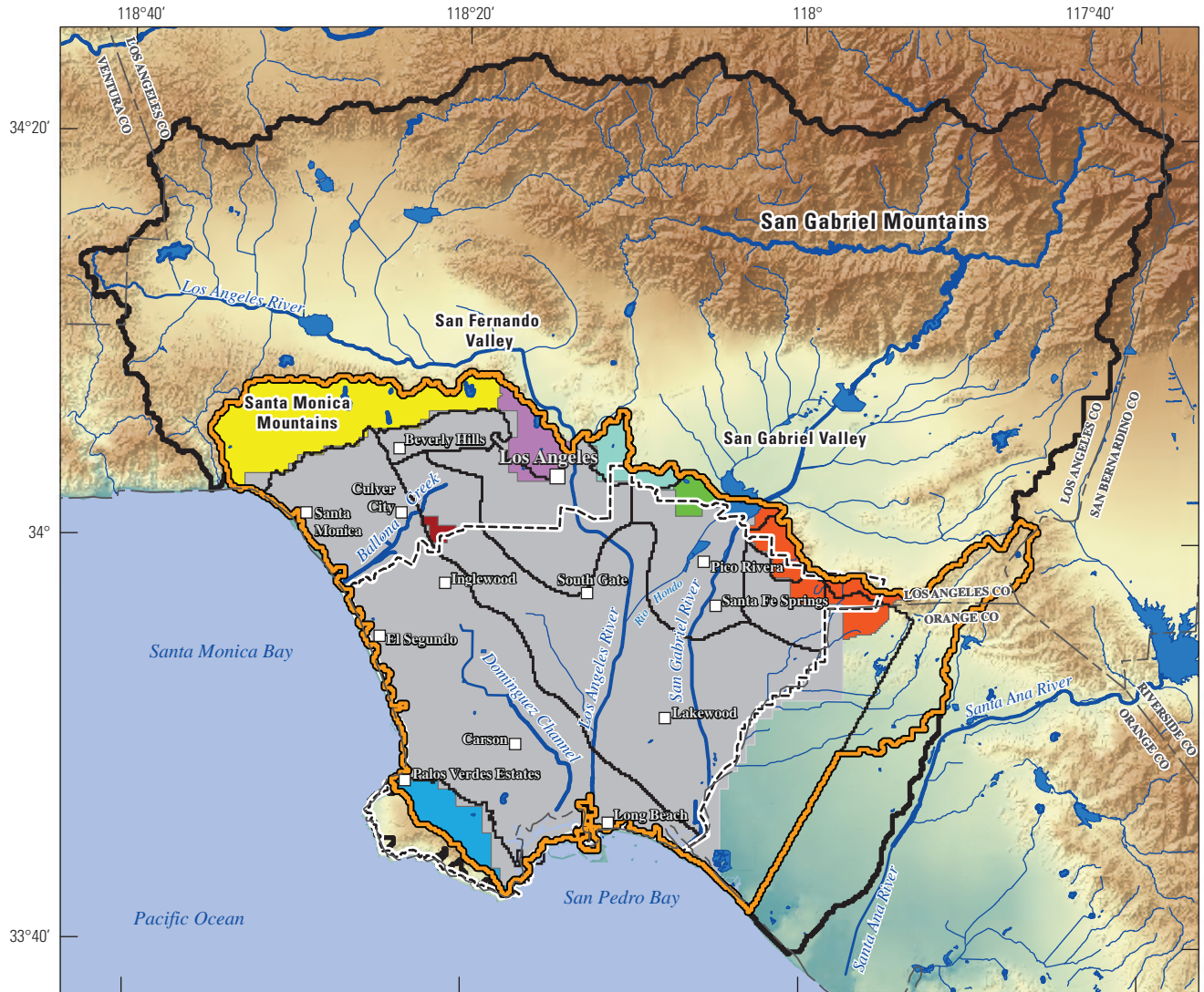
The LABWM results indicated that most of the recharge volume was in the internal recharge area, which is similar to the previous recharge estimates obtained for the LAGSA. The 30-year-average direct recharge simulated by the LABWM for the internal area was 5,350 ha-m/yr, compared to only 2,650 ha-m/yr simulated by the LABWM for the contributing mountain-front recharge areas.

The LABWM results were also compared to previous estimates of recoverable water for basins in the southern California region (Crippen, 1965). Recoverable water was defined by Crippen (1965) as the sum of recharge and runoff. For the comparison, recoverable water was plotted against effective precipitation in the LABWM subbasins and the basins analyzed by Crippen (1965). The LABWM results both included the with and without urban irrigation simulations. For the with irrigation results, the sum of precipitation and irrigation was referred to as effective precipitation. The LABWM results tended to indicate greater recoverable water amounts for a given amount of effective precipitation compared to results obtained by Crippen (1965; fig. 52). The high percentage of impervious area used in the LABWM likely caused more runoff than in most of the basins analyzed by Crippen (1965). A better match between the LABWM results and the estimates of recoverable water by Crippen (1965) was obtained when urban irrigation was included.





**Figure 49.** Comparison of simulation results for subdomains by using a range of urban irrigation estimates, Los Angeles Basin watershed model (LABWM), California: *A*, percentage of contribution of urban irrigation to recharge; *B*, percentage of contribution of urban irrigation estimates to evapotranspiration.



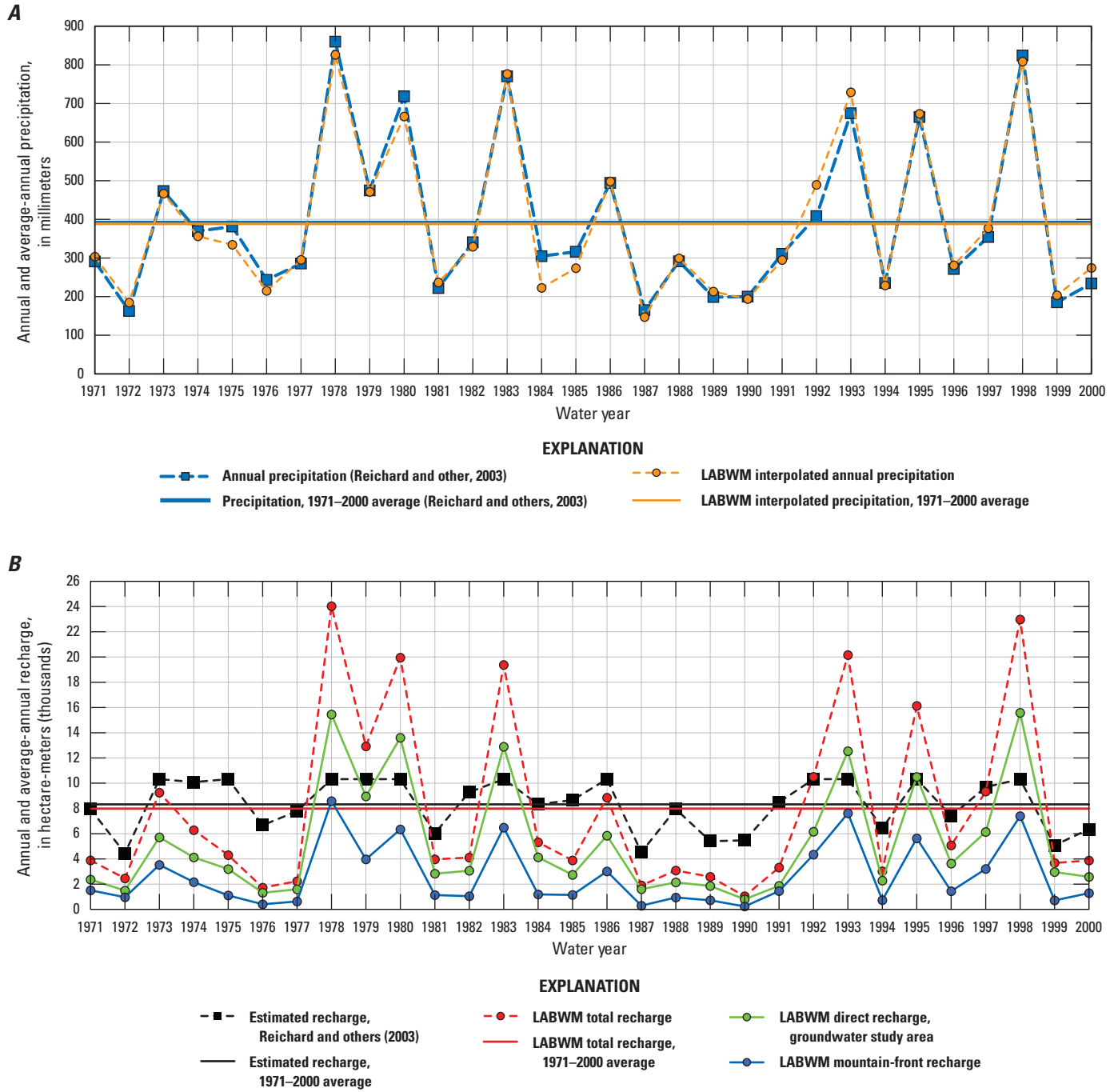
Base modified from U.S. Geological Survey and other State digital data, various scales  
 Universal Transverse Mercator, zone 11  
 North American Datum 1983



**EXPLANATION**

- |  |   |
|--|---|
| <p><b>Recharge areas used for comparison to previous recharge estimates</b></p> <ul style="list-style-type: none"> <li><span style="display: inline-block; width: 15px; height: 10px; background-color: #cccccc; border: 1px solid black; margin-right: 5px;"></span> Internal recharge area</li> </ul> <p><b>Contributing recharge areas</b></p> <ul style="list-style-type: none"> <li><span style="display: inline-block; width: 15px; height: 10px; background-color: #800000; border: 1px solid black; margin-right: 5px;"></span> Baldwin Hills</li> <li><span style="display: inline-block; width: 15px; height: 10px; background-color: #800080; border: 1px solid black; margin-right: 5px;"></span> Elysian Hills</li> <li><span style="display: inline-block; width: 15px; height: 10px; background-color: #008000; border: 1px solid black; margin-right: 5px;"></span> Merced Hills</li> <li><span style="display: inline-block; width: 15px; height: 10px; background-color: #008080; border: 1px solid black; margin-right: 5px;"></span> Palo Verdes Hills</li> <li><span style="display: inline-block; width: 15px; height: 10px; background-color: #ff4500; border: 1px solid black; margin-right: 5px;"></span> Repetto Hills</li> <li><span style="display: inline-block; width: 15px; height: 10px; background-color: #ffff00; border: 1px solid black; margin-right: 5px;"></span> Santa Monica Mountains</li> </ul> | <ul style="list-style-type: none"> <li><span style="display: inline-block; width: 20px; border-top: 2px solid black; margin-right: 5px;"></span> Los Angeles Basin watershed model area boundary</li> <li><span style="display: inline-block; width: 20px; border-top: 2px dashed black; margin-right: 5px;"></span> Water Replenishment District</li> <li><span style="display: inline-block; width: 20px; border-top: 2px solid orange; margin-right: 5px;"></span> Los Angeles recharge study area</li> <li><span style="display: inline-block; width: 15px; height: 10px; background-color: #0070c0; border: 1px solid black; margin-right: 5px;"></span> Water bodies and flood-control areas</li> <li><span style="display: inline-block; width: 15px; height: 10px; background-color: #0070c0; border: 1px solid black; margin-right: 5px;"></span> Major rivers and streams</li> <li><span style="display: inline-block; width: 15px; height: 10px; background-color: #0070c0; border: 1px solid black; margin-right: 5px;"></span> Minor rivers and streams</li> <li><span style="display: inline-block; width: 15px; height: 10px; background-color: #0070c0; border: 1px solid black; margin-right: 5px;"></span> Los Angeles groundwater basins</li> <li><span style="display: inline-block; width: 15px; border-bottom: 1px dashed black; margin-right: 5px;"></span> County line</li> </ul> |
|--|---|

**Figure 50.** Internal and contributing recharge areas used for previous recharge estimates, Los Angeles Basin watershed model (LABWM), California.



**Figure 51.** Comparison of annual results from a previous study and results from using the Los Angeles Basin watershed model (LABWM), California, for *A*, precipitation; and *B*, recharge.

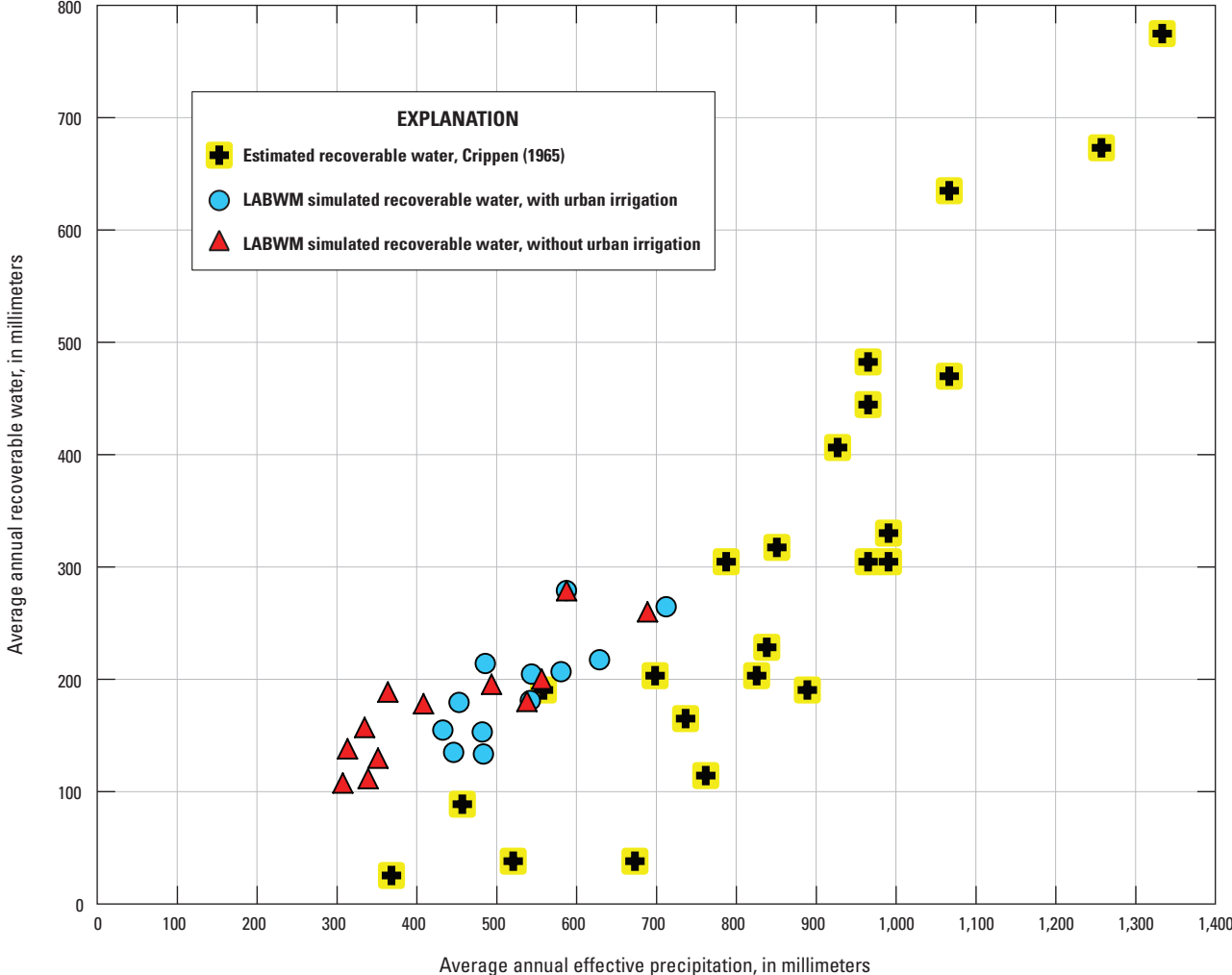


Figure 52. Comparison of recoverable water with effective precipitation obtained with previous studies and with the Los Angeles Basin watershed model (LABWM), California.



## Model Limitations

A primary limitation of the LABWM applied in this study is the uncertainty in model calibration using a comparison of simulated runoff to available streamflow records. The LABWM does not account for regulated streamflow, and only a few unregulated streamflow records were available for calibration. The watershed area upstream from the unregulated streamflow-gaging stations used for calibration included only a fraction of the total area modeled by using the LABWM. In addition, the length of most of the streamflow records used for model calibration did not span the full simulation period. Model uncertainty for simulated recharge is assumed to be greater than simulated runoff because the model is not calibrated directly to recharge data, which generally is not available. Additional data used for calibration, such as measurements of soil moisture at varying depths and times, could greatly reduce the uncertainty in simulated recharge.

A major assumption applied in the LABWM was that runoff generated in response to rainfall, snowmelt, irrigation, and shallow subsurface-seepage flow is the primary component of streamflow measured in the study area. Streamflow resulting from deep groundwater discharge, wastewater discharge, or flow diversions was not represented by the LABWM. In addition, simulation of streamflow was based on a daily routing algorithm that assumed all streamflow either discharges from the drainage basin or infiltrates into the root zone at the end of each day. This limitation could cause an overestimation of streamflow and a corresponding under- or overestimation of recharge. Streamflow was overestimated because the dampening effect (time delay) caused by channel storage of water (including reservoirs and retention basins) was not accounted for. This increased streamflow either can cause an over- or underestimation of recharge, depending on the location and the effective hydraulic conductivity of the channel represented by the model.

Dispersive streamflow (divergent as opposed to convergent streamflow), which can be an important characteristic of streamflow and overland flow across alluvial fans and basins with braided channels, was not directly represented in the surface-water flow-routing algorithm. All surface-water flow was simulated as convergent streamflow. These limitations in simulating surface-water flow could result in an overestimation of recharge in some parts of the study area, particularly in the higher elevation sub-drainage basins and along the mountain front to basin transition.

Although relatively high-resolution (30-m) data were used in this study for defining the percentage of impervious areas for model cells, uncertainty remains about the effective impervious area represented in the model. The effective impervious area includes only those impervious surfaces generating runoff that is routed to downstream cells. In actuality, a large amount of runoff generated by impervious surfaces is routed to pervious areas in the same cell, rather than a downstream cell. For example, runoff from an impervious roof can be routed directly to the pervious lawn

area rather than an impervious street gutter or storm drain. Impervious area runoff routed to pervious areas potentially does not generate runoff for the cell.

Storm runoff is modeled as a cascading flow process in the LABWM. For a given cell, surface-water run-on (inflow from upstream cells) is distributed to the area of the cell (as a uniform inflow depth). In developed urbanized areas, however, storm runoff from impervious areas is usually collected by a network of storm drains that directly connect with the main channels. In doing so, the storm drains cause a more rapid hydrologic response to storms. Although the LABWM empirically accounts for channelized flow in the larger channels, the highly channelized flow along street gutters and through the storm-drain network is not directly represented by the model.

The physical characteristics of the watersheds defined in the LABWM are static; they do not change with time. Changes in land use and land cover caused by factors such as urbanization and wildfires can cause great changes through time in imperviousness, vegetation, land-cover characteristics, and stream-channel characteristics that are not represented by the model. Examination of land-use data sets and results from model calibration and testing indicated that watershed characteristics were likely to have changed notably during the target-simulation period (water years 1915–2014).

Although snow does not fall in the LAGSA or in most of the LABWM area, snow is an important component of the hydrologic system in the higher elevation drainages of the San Gabriel Mountains. The streamflow records used for model calibration did not include these higher elevation drainages, and therefore, the calibrated model had a high degree of uncertainty in the simulation of snow fall and snow melt in the San Gabriel Mountains. In the LABWM area, snow was simulated only when the average daily air temperature was 0 °C or less. In actuality, notable snow can accumulate during storms when the average recorded air temperature is greater than 0 °C. Additional model calibration for the headwater drainages in the San Gabriel Mountains could improve the simulation of recharge and runoff for these locations.

Additional limitations are associated with the urban-irrigation estimates developed in this study. A key assumption of the minimum-month method is that during the minimum-month, landscaped vegetation does not receive any irrigation, but relies solely on natural rainfall. This is most likely not the case in many areas of the southwest, where rainfall can be sporadic, and home owners leave automatic sprinkler systems turned on. Consequently, the minimum-month method is prone to an underestimation of outdoor water use (Department of Water Resources, 1994; DeOreo and others, 1996; Mayer and others, 1999; Gleick and others, 2003).

Another assumption was that the irrigation rate for single-family neighborhoods was representative of the rate in other land-use classes. Typical residential neighborhood landscaping consists of grasses, trees, and bushes, which is similar to the landscaping in commercial or other urbanized

land uses. Theoretically, the water used to maintain those plants is similar, regardless of the type of land-use class in which they are maintained; however, this assumption has not been validated to date.

A further consideration is that of the land-use map. Land cover for a select number of land-use classes in the San Fernando Valley was hand digitized in order to test the accuracy of the reported imperviousness from the LACDPW (Johnson and Belitz, 2012). The results showed that the LACDPW dataset was very good at estimating perviousness in the less vegetated land-use classes, but overestimated it in the single-family residential class. An overestimation would cause more water to be applied to the landscape.

Lastly, if a particular land use was designated as containing irrigated vegetation (table 10), it was assumed that all pervious areas in that land use were irrigated. This is not always the case, however. Many pervious areas, such as barren landscapes or vacant land parcels, are not irrigated.

Daily PET was simulated by using an hourly time step and an energy-balance model to improve the representation of the shading effects of rugged terrain relative to changes in solar position during the year (Flint and Childs, 1987). Daily ET was simulated as a combined function of daily PET; the vertical distribution of available water in the root-zone layers; and the root-zone density, where the root-zone density represents the characteristics of vegetation. Variations in root density were not adjusted or varied according to differences in soil texture; however, the effect of soil properties on ET was accounted for indirectly by differences in layer thickness, water-holding capacity, and vertical hydraulic conductivity.

## Summary and Conclusions

A daily precipitation-runoff model, the Los Angeles Basin watershed model (LABWM), was used to estimate recharge and runoff for the principal groundwater basins underlying the greater Los Angeles area, referred to in this study as the Los Angeles groundwater study area (LAGSA). The area of interest for estimating recharge to the LAGSA, the Los Angeles recharge-study area, included tributary drainages upstream from and peripheral to the LAGSA boundary. The tributary drainages have the potential to contribute a large amount of recharge to the LAGSA. The LABWM uses the distributed-parameter INFILv3 precipitation-runoff modeling code for simulating spatially and temporally variable recharge and runoff on a daily time step. The recharge estimates were used to develop spatially and temporally distributed recharge for the LAGSA and also mountain-front recharge for the peripheral drainages. The mountain-front recharge simulated for the tributary upland areas bordering the LAGSA was combined with the direct recharge simulated for the internal area of the LAGSA in order to define the total potential transient recharge for the LAGSA. An important aspect of the application of the LABWM for recharge estimation is that the

effect of climate variability on recharge is deterministically simulated by using a process-based daily water balance calculation, rather than an empirical approach, where recharge is estimated as a statistical function of precipitation. Variations in recharge in response to the spatial variability of watershed characteristics are also directly accounted for in the distributed-parameter, deterministic simulation. Another important aspect of the LABWM application for estimating recharge is that urban irrigation was included in the daily water-balance simulation and, therefore, it accounted for increased recharge from urban irrigation return flows.

A gridded discretization of the LABWM area was used to represent spatially distributed climate and watershed characteristics affecting the surface and shallow sub-surface hydrology. Daily climate data obtained from a local network of 201 monitoring sites and PRISM-derived average monthly precipitation and maximum and minimum air temperature maps for the 30-year period (1971–2000) were used to develop the climate inputs for the LABWM. Data from 2001 defining topography, land use, land cover, soils, vegetation, and surficial geology were used as input to represent the contemporary conditions of the physical characteristics of the LABWM area. A new method for estimating urban irrigation (representing mostly residential and commercial landscape watering) based on land use and the percentage of imperviousness was incorporated into the LABWM. The urban-irrigation estimates were defined on a quarterly basis to account for seasonal changes in water demand.

The LABWM was calibrated by using available records of streamflow at six streamflow gaging stations within the LABWM. The six gages included three gages with drainage areas in the LAGSA and three gages outside of, but next to, the LAGSA. The calibration was limited because the drainage areas for the six gages did not include most of the LABWM area and because the drainage areas upstream from the gages did not represent all the characteristics and conditions of the LABWM area. The comparison between simulated and measured streamflow was good for the three gages in the LAGSA and satisfactory for the three gages next to the LAGSA, indicating an acceptable overall calibration for the six gages and for most of the goodness-of-fit statistics considered. The satisfactory calibration result included PAEE values within plus or minus 20 percent and NSME values of 0.7 or greater for most of the streamflow components analyzed for all six gages.

The best calibration was obtained for gage BALC6, with a PAEE of –6 and NSME values of 0.74 for daily streamflow, 0.93 for monthly streamflow, and 0.82 for average water year streamflow. The next best calibration was obtained for gage COYC1, with PAEE values of 10 to 11 and NSME values of 0.77 for daily mean discharge, 0.87 for average monthly streamflow, and 0.83 for average water year streamflow. Results for gage ALHW6 showed a good calibration for daily and monthly streamflow, with NSME values of 0.78 and 0.94, respectively. Calibration results for average water-year streamflow, however, were poor for gage ALHW6, with an

NSME of only 0.52. There was a moderate tendency of the model to underestimate streamflow at this location, resulting in PAEE values of -14 to -18. Calibration results for gage COMP4 were good for daily and monthly streamflow, with a PAEE of 18 and NSME values of 0.76 for daily flow and 0.81, for monthly flow; however, the results for average water-year streamflow indicated a poor calibration, with a PAEE of 23 and NSME of only 0.57. For this location, there was a moderate tendency of the model to overestimate streamflow. The NSME results for gage SJCE1 were good for daily, monthly, and average water-year streamflow, with values of 0.74 or greater. The best results for gage SJCE1 were obtained for monthly streamflow, with an NSME of 0.91 indicating an excellent model fit. The PAEE of -16 for gage SJCE1 indicated an overall tendency to underestimate streamflow but was considered satisfactory for model calibration and was within the PAEE calibration criteria of plus or minus 20 that was used in calibrating the LABWM. The PAEE results of 3 and 4 obtained for gage TOPG1 indicate a very good calibration in terms of minimal estimation bias. The monthly NSME of 0.68 and the annual result of 0.73 indicated satisfactory and good calibration results, respectively, however the daily NSME result of 0.35 indicated a poor fit to daily streamflow at gage TOPG1.

Model application to a 100-year target-simulation period, from water years 1915 through 2014, was used to quantify and evaluate spatial and temporal variability of water-budget components, including evapotranspiration (ET), recharge, and runoff. The largest outflow of water from the LABWM area was ET; the 100-year average ET rate of 362 mm/yr (182,473 ha-m/yr) represented 65 percent of the combined water inflow of 488 mm/yr (246,405 ha-m/yr) from precipitation and 63 mm/yr (31,906 ha-m/yr) from urban irrigation. Simulated ET rates within the LABWM area varied from a minimum of 0–100 mm/yr for impervious areas to high values of more than 1,000 mm/yr for many locations, including the south-facing slopes of the San Gabriel Mountains, stream channels underlain by permeable soils and thick root zones, and pervious locations receiving inflows both from urban irrigation and runoff. After ET, surface-water runoff was the next largest outflow from the LABWM, averaging 145 mm/yr (73,212 ha-m/yr) for the 100-year period, or 26 percent of the combined precipitation and urban irrigation inflow. Recharge averaged 45 mm/yr (22,577 ha-m/yr), or about 8 percent of the combined inflow from precipitation and urban irrigation.

Simulation results indicated that recharge in response to urban irrigation was an important component of spatially distributed recharge, contributing more than 50 percent of the total recharge to many of the groundwater basins in the LAGSA. For the eight subdomains included in the LABWM area that contained the LAGSA, urban irrigation contributed 23 mm/yr (4,733 ha-m/yr) to the total recharge of 41 mm/yr (8,473 ha-m/yr), accounting for 56 percent of the total recharge.

Simulation results indicated that mountain front recharge from adjacent upland areas and hilly drainages outside of but tributary to the lower lying area of the groundwater basins made an important contribution to the total recharge. The mountain front recharge was assumed to occur as groundwater underflow from the upland areas into the LAGSA, and was assumed to be equal to the total direct recharge simulated for upland drainages. The time-averaged recharge rate was similar to the combined direct- and mountain-front recharge estimates developed in a previous study of the LAGSA and used as input for a calibrated groundwater flow model. The annual (water year) recharge estimates provided by the LABWM simulation, however, indicated much greater year-to-year variability compared to the previous estimates that were based on an empirical function of annual precipitation. The greater year-to-year variability in the LABWM recharge estimate was most strongly correlated to the year-to-year variability in precipitation and to variations in the timing, magnitude, and frequency of daily precipitation. In addition, the LABWM recharge estimates indicate a high degree of spatial variability caused by spatially varying drainage basin characteristics, climate, and urban irrigation.

## References Cited

- Beven, K. J., and Kirkby, M. J., 1979, A physically based, variable contributing area model of basin hydrology: Hydrological Sciences–Bulletin, no. 24, v. 1, p. 43–69, <http://soilandwater.bee.cornell.edu/research/VSA/papers/BevenHSB79.pdf>.
- California Department of Forestry and Fire Protection, 2002, Monitoring land cover changes in California: California Land Cover Mapping and Monitoring Program, South Coast Project Area, July 2002, 161 p., accessed January 20, 2015, at [http://frap.cdf.ca.gov/projects/land\\_cover/monitoring/pdfs/socdp\\_final2.pdf](http://frap.cdf.ca.gov/projects/land_cover/monitoring/pdfs/socdp_final2.pdf).
- California Department of Fish and Wildlife. California Interagency Wildlife Task Group, 2014, User's manual for version 9.0 of the California Wildlife Habitat Relationships System and Bioview: Sacramento, California, 54 p., <https://www.dfg.ca.gov/biogeodata/cwhr/>.
- California Department of Water Resources, 1975, California's ground water: State of California Bulletin no. 118, 8 p., <http://water.ca.gov/groundwater/bulletin118.cfm>.
- California Department of Water Resources, 1994, Urban water use in California: State of California Bulletin No. 166-4, <http://www.water.ca.gov/historicaldocs/irwm/b166-1994/ch1.html>.



- California Irrigation Management Information System (CIMIS), 2005, Meteorological data: California Department of Water Resources and University of California at Davis, <http://www.cimis.water.ca.gov/>.
- City of Los Angeles Department of Water and Power, 2001, Urban water management plan, fiscal year 2000–2001 annual update: City of Los Angeles, Los Angeles, Calif.
- Crippen, J.R., 1965, Natural water loss and recoverable water in mountain basins of southern California: U.S. Geological Survey Professional Paper 417-E, p. E1–E24, <https://pubs.er.usgs.gov/publication/pp417E>.
- Daly, C., Neilson, R.P., and Phillips, D.L., 1994, A statistical-topographic model for mapping climatological precipitation over mountainous terrain: *Journal of Applied Meteorology*, v. 33, no. 2, p. 140–158.
- Daly, Christopher, Gibson, Wayne, Doggett, Matt, Smith, Joseph, and Taylor, George, 2004, Up-to-date monthly climate maps for the conterminous United States: Procedures of the 14th American Meteorological Society Conference on Applied Climatology, 84th AMS Annual Meeting Combined Preprints, American Meteorological Society, Seattle, Washington, January 13–16, 2004, Paper P5.1, CD-ROM, [http://www.prism.oregonstate.edu/documents/pubs/2004appclim\\_monthlyMaps\\_daly.pdf](http://www.prism.oregonstate.edu/documents/pubs/2004appclim_monthlyMaps_daly.pdf).
- DeOreo, W.B., Heaney, J.P., and Mayer, P.W., 1996, Flow trace analysis to assess water use: *Journal of the American Water Works Association*, January 1996, v. 88, no. 1, p. 79–90, <http://www.awwa.org/publications/journal-awwa/abstract/articleid/13497/issueid/33522453.aspx?getfile=\\pers75apppr\personify\serverfiles\dcdfiles\13497\waternet.0039526.pdf>.
- Farrar, C.D., Metzger, L.F., Nishikawa, Tracy, Koczot, K.M., and Reichard, E.G., 2006, Geohydrological characterization, water-chemistry, and ground-water flow simulation model of the Sonoma Valley area, Sonoma County, California, with a section on Basement rock configuration interpreted from gravity data by Victoria E. Langenheim: U.S. Geological Survey Scientific Investigations Report 2006–5092, 167 p., <https://pubs.er.usgs.gov/publication/sir20065092>.
- Flint, A.L., and Childs, S.W., 1987, Calculation of solar radiation in mountainous terrain: *Journal of Agricultural and Forest Meteorology*, v. 40, no. 3, p. 233–249, [http://dx.doi.org/10.1016/0168-1923\(87\)90061-X](http://dx.doi.org/10.1016/0168-1923(87)90061-X).
- Flint, L. E., and Flint, A. L., 2007, Regional analysis of ground-water recharge, in Stonestrom, D.A., Constantz, Jim, Ferre, T.P.A., and Leake, S.A., eds., *Ground-water recharge in the arid and semiarid southwestern United States*: U.S. Geological Survey Professional Paper 1703-B, p. 29–60, <https://pubs.er.usgs.gov/publication/pp1703B>.
- Flint, L.E., and Flint, A.L., 2012, Simulation of climate change in San Francisco Bay Basins, California: Case studies in the Russian River Valley and Santa Cruz Mountains: U.S. Geological Survey Scientific Investigations Report 2012–5132, 55 p., <https://pubs.er.usgs.gov/publication/sir20125132>.
- Flint, L.E., and Martin, Peter, eds., with contributions by Brandt, Justin, Christensen, A.H., Flint, A.L., Flint, L.E., Hevesi, J.A., Jachens, Robert, Kulongoski, J.T., Martin, Peter, and Sneed, Michelle, 2012, *Geohydrology of Big Bear Valley, California: Phase 1—Geologic framework, recharge, and preliminary assessment of the source and age of groundwater*: U.S. Geological Survey Scientific Investigations Report 2012–5100, 112 p., <https://pubs.er.usgs.gov/publication/sir20125100>.
- Gleick, P.H., Haasz, Dana, Henges-Jeck, Christine, Srinivasan, Veena, Wolff, Gary, Cushing, K.K., and Mann, Amardip, 2003, Waste not, want not: The potential for urban water conservation in California: Pacific Institute for Studies in Development, Environment, and Security. 165 p., [http://www.pacinst.org/wp-content/uploads/sites/21/2013/02/waste\\_not\\_want\\_not\\_full\\_report3.pdf](http://www.pacinst.org/wp-content/uploads/sites/21/2013/02/waste_not_want_not_full_report3.pdf).
- Grimmond, C.S.B. and Oke, T.R., 1986, Urban water balance: 2. Results from a suburb of Vancouver, British Columbia: *Water Resources Research*, v. 22, no. 10, p. 1404–1412, <http://dx.doi.org/10.1029/WR022i010p01404>.
- Grimmond, C.S.B., Oke, T.R., and Steyn, D.G., 1986, Urban water balance: 1. A model for daily totals: *Water Resources Research*, v. 22, no. 10, p. 1397–1403, <http://dx.doi.org/10.1029/WR022i010p01397>.
- Hevesi, J.A., and Christensen, A.H., 2015, Estimating natural recharge in San Geronio Pass watersheds, California, 1913–2012: U.S. Geological Survey Scientific Investigations Report 2015–5122, 74 p., <http://dx.doi.org/10.3133/sir20155122>.
- Hevesi, J.A., Flint, A.L., and Flint, L.E., 2003, Simulation of net infiltration and potential recharge using a distributed-parameter watershed model of the Death Valley region, Nevada and California: U.S. Geological Survey Water-Resources Investigation Report 2003–4090, 171 p., <https://pubs.er.usgs.gov/publication/wri034090>.
- Hevesi, J.A., Flint, L.E., Church, C.D., and Mendez, G.O., 2011, Application of a watershed model (HSPF) to evaluating sources and transport of pathogen indicators in the Chino Basin drainage area, San Bernardino County, California: U.S. Geological Survey Scientific Investigations Report 2009–5219, 142 p., <https://pubs.er.usgs.gov/publication/sir20095219>.
- Jennings, C.W., 1977, Geologic map of California: California Division of Mines and Geology Geologic Data Map no. 2, scale 1:750,000.



- Jeton A.E., and Maurer, D.K., 2011, Precipitation and runoff simulations of select perennial and ephemeral watersheds in the middle Carson River basin, Eagle, Dayton, and Churchill Valleys, west-central Nevada: U.S. Geological Survey Scientific Investigations Report 2011–5066, 44 p., <https://pubs.er.usgs.gov/publication/sir20115066>.
- Johnson, T.D., 2005, Predicting residential irrigation amounts using satellite remote sensing in Los Angeles, California, Master's thesis, San Diego State University, 73 p.
- Johnson, T.D., and Belitz, Kenneth, 2012, A remote sensing approach for estimating the location and rate of urban irrigation in semi-arid climates: *Journal of Hydrology*, v. 414–415, p. 86–98, <http://dx.doi.org/10.1016/j.jhydrol.2011.10.016>.
- Los Angeles County Department of Public Works, Water Resources Division, 2006, Hydrology manual. Appendix D, Proportion Impervious Data. Digital polygon dataset.
- Maidment, D.R. (ed), 1993, *Handbook of Hydrology*: McGraw-Hill, Inc., p. 7.5.
- Maidment, D.R. (ed), 2002, *Arc Hydro: GIS for water resources*: Redlands, California, ESRI Press.
- Markstrom, S.L., Niswonger, R.G., Regan, R.S., Prudic, D.E., and Barlow, P.M., 2008, GSFLOW—Coupled ground-water and surface-water flow model based on the integration of the Precipitation-Runoff Modeling System (PRMS) and the Modular Ground-Water Flow Model (MODFLOW-2005): *U.S. Geological Survey Techniques and Methods 6-D1*, 240 p., <https://pubs.er.usgs.gov/publication/tm6D1>.
- Maxey, G.B., and Eakin, T.E., 1949, Ground water in White River Valley, White Pine, NYE, and Lincoln counties, Nevada: State of Nevada, Office of the State Engineer, in cooperation with the U.S. Department of the Interior, Geological Survey, 59 p., [http://forestry.state.nv.us/hearings/past/springetal/browseabledocs/exhibits/snwa%20exhibits/snwa\\_exh\\_290\\_maxey%20and%20eakin,%201949.pdf](http://forestry.state.nv.us/hearings/past/springetal/browseabledocs/exhibits/snwa%20exhibits/snwa_exh_290_maxey%20and%20eakin,%201949.pdf).
- Mayer, P.W., DeOreo, W.B., Opitz, E.M., Kiefer, J.C., Davis, W.Y., Dziegielewski, Benedykt, Nelson, J.O., 1999, Residential end uses of water: American Water Works Association Research Foundation, Denver, Colorado, 310 p., [http://www.waterrf.org/publicreportlibrary/rfr90781\\_1999\\_241a.pdf](http://www.waterrf.org/publicreportlibrary/rfr90781_1999_241a.pdf).
- Milesi, C., Running, S.W., Elvidge, C.D., Dietz, J.B., Tuttle, B.T., and Nemani, R.R., 2005, Mapping and modeling the biogeochemical cycling of turf grasses in the United States: *Environmental Management*, v. 36, no. 3, p. 426–438, <http://dx.doi.org/10.1007/s00267-004-0316-2>.
- Nash, J.E., and Sutcliffe, J.V., 1970, River flow forecasting through conceptual models part I—A discussion of principals: *Journal of Hydrology*, v. 10, no. 3, p. 282–290, [http://dx.doi.org/10.1016/0022-1694\(70\)90255-6](http://dx.doi.org/10.1016/0022-1694(70)90255-6).
- Nishikawa, Tracy, Izbicki, J.A., Hevesi, J.A., Stamos, C.L., and Martin, Peter, 2005, Evaluation of geohydrologic framework, recharge estimates and ground-water flow of the Joshua Tree area, San Bernardino County, California: U.S. Geological Survey Scientific Investigations Report 2004–5267, 127 p., <https://pubs.er.usgs.gov/publication/sir20045267>.
- Reichard, E.G., Land, Michael, Crawford, S.M., Johnson, T.D., Everett, Rhett, Kulshan, T.V., Ponti, D.J., Halford, K.L., Johnson, T.A., Paybins, K.S., and Nishikawa, Tracy, 2003, *Geohydrology, Geochemistry, and Ground-Water Simulation—Optimization of the Central and West Coast Basins*, Los Angeles County, California: U.S. Geological Survey Water-Resources Investigations Report 2003–4065, 196 p., <https://pubs.er.usgs.gov/publication/wri034065>.
- Rewis, D.L., Christensen, A.H., Matti, Jonathan, Hevesi, J.A., Nishikawa, Tracy, and Martin, Peter, 2006, *Geology, ground-water hydrology, geochemistry, and ground-water simulation of the Beaumont and Banning storage units, San Gorgonio Pass area, Riverside County, California*: U.S. Geological Survey Scientific Investigations Report 2006–5026, 191 p., <https://pubs.er.usgs.gov/publication/sir20065026>.
- Sample, D.J., and Heaney, J.P., 2006, Integrated management of irrigation and urban storm-water infiltration: *Journal of Water Resources Planning and Management*, v. 132, no. 5, p. 362–373, [http://dx.doi.org/10.1061/\(ASCE\)0733-9496\(2006\)132:5\(362\)](http://dx.doi.org/10.1061/(ASCE)0733-9496(2006)132:5(362)).
- San Diego County Water Authority, 2001, A common need, with shared solutions, Annual report 2001: San Diego County Water Authority, San Diego, CA, 49 p., [http://www.sdcwa.org/sites/default/files/files/publications/annual\\_2001.pdf](http://www.sdcwa.org/sites/default/files/files/publications/annual_2001.pdf).
- Southern California Area Governments, 2005, Los Angeles County land use, Digital polygon dataset.
- U.S. Department of Agriculture, 1994, *State Soil Geographic (STATSGO) Data Base—Data use information*: Natural Resource Conservation Service, Miscellaneous Publication no. 1492: Soil Survey Staff, Natural Resources Conservation Service, United States Department of Agriculture. U.S. General Soil Map (STATSGO) for California, accessed December 12, 2001, at <http://sdmdataaccess.nrcs.usda.gov/>.

- U.S. Geological Survey, 2001, The national map seamless server database, <http://www.webgis.com/usgsseam.html>.
- U.S. Geological Survey, 2005, National Land Cover Database—Zone 60 Imperviousness layer: U.S. Geological Survey data available on the World Wide Web, accessed May 16, 2005, at <http://seamless.usgs.gov>.
- U.S. Geological Survey, 2008, Documentation of computer program INFIL3.0—A distributed-parameter watershed model to estimate net infiltration below the root zone: U.S. Geological Survey Scientific Investigation Report 2008–5006, 98 p. <http://water.usgs.gov/nrp/gwsoftware/Infil/Infil.html>.
- Water Replenishment District of Southern California, 2013, Engineering Survey and Report, Updated May 10, 2013, 70 p., [http://www.wrd.org/WRD\\_ESR2013\\_May4\\_Final\\_Report\\_web.pdf](http://www.wrd.org/WRD_ESR2013_May4_Final_Report_web.pdf).
- Westenbroek, S.M., Kelson, V.A., Dripps, W.R., Hunt, R.J., and Bradbury, K.R., 2010, SWB-A modified Thornthwaite-Mather Soil-Water-Balance code for estimating groundwater recharge: U.S. Geological Survey Techniques and Methods 6-A31, 52 p., <https://pubs.er.usgs.gov/publication/tm6A31>.
- Woolfenden, L.R., and Nishikawa, Tracy, eds., 2014, Simulation of groundwater and surface-water resources of the Santa Rosa Plain watershed, Sonoma County, California: U.S. Geological Survey Scientific Investigations Report 2014–5052, 258 p., <http://dx.doi.org/10.3133/sir20145052>.



## **Appendix 1**

---



**Table 1-1.** Los Angeles Basin watershed model.

[ha-m, hectare-meter; mm, millimeter]

Water year	Potential evapotranspiration (mm)	Urban irrigation (mm)	Precipitation (mm)	Actual evapotranspiration (mm)	Direct recharge (mm)	Storage change (mm)	Surface-water discharge (mm)
1915	1,180	63	642	436	75	2	191
1916	1,191	63	706	400	93	14	263
1917	1,167	63	514	411	56	-20	131
1918	1,211	63	499	346	50	1	165
1919	1,201	63	373	328	24	20	65
1920	1,196	63	478	419	38	-37	121
1921	1,180	63	523	427	33	8	119
1922	1,207	63	778	434	96	5	306
1923	1,197	63	404	363	35	-12	81
1924	1,224	63	283	298	15	-13	45
1925	1,204	63	329	332	12	-6	55
1926	1,222	63	581	417	35	6	187
1927	1,209	63	612	395	60	8	212
1928	1,235	63	376	349	27	-8	71
1929	1,225	63	386	356	22	-3	74
1930	1,238	63	407	344	29	-0	97
1931	1,262	63	426	371	27	-2	93
1932	1,202	63	611	387	71	10	205
1933	1,203	63	370	299	35	-7	106
1934	1,275	63	445	313	28	-3	170
1935	1,204	63	676	466	61	14	197
1936	1,246	63	409	341	37	-10	105
1937	1,203	63	776	454	94	19	273
1938	1,217	63	784	417	94	8	327
1939	1,228	63	560	353	50	34	187
1940	1,247	63	438	405	42	-48	103
1941	1,176	63	1,091	513	168	47	426
1942	1,209	63	382	386	39	-37	57
1943	1,234	63	718	409	64	3	305
1944	1,200	63	650	397	79	5	233
1945	1,214	63	465	378	43	-10	117

**Table 1-1.** Los Angeles Basin watershed model.—Continued

[ha-m, hectare-meter; mm, millimeter]

Water year	Potential evapotranspiration (mm)	Urban irrigation (mm)	Precipitation (mm)	Actual evapotranspiration (mm)	Direct recharge (mm)	Storage change (mm)	Surface-water discharge (mm)
1946	1,238	63	421	345	27	-9	120
1947	1,237	63	473	353	42	-3	145
1948	1,220	63	257	282	13	-11	37
1949	1,212	63	283	280	16	-5	54
1950	1,230	63	344	317	21	-2	71
1951	1,239	63	247	271	9	-6	36
1952	1,204	63	829	456	79	33	323
1953	1,226	63	310	310	30	-19	52
1954	1,243	63	392	338	26	-3	95
1955	1,223	63	364	341	20	-2	68
1956	1,233	63	443	348	21	0	137
1957	1,239	63	352	331	19	-4	70
1958	1,211	63	798	480	83	21	277
1959	1,295	63	240	266	21	-23	39
1960	1,280	63	276	279	15	-4	49
1961	1,261	63	182	219	8	-8	26
1962	1,219	63	600	371	52	19	222
1963	1,223	63	339	320	15	2	66
1964	1,233	63	272	295	11	-16	44
1965	1,205	63	430	362	23	4	105
1966	1,260	63	615	351	61	6	261
1967	1,219	63	694	456	53	15	233
1968	1,269	63	399	342	36	-14	99
1969	1,223	63	931	422	102	28	442
1970	1,267	63	298	301	23	-26	63
1971	1,249	63	405	312	30	-2	129
1972	1,274	63	242	232	19	-9	62
1973	1,219	63	610	401	57	15	200
1974	1,253	63	453	344	41	-3	135
1975	1,210	63	424	366	28	-0	94
1976	1,241	63	343	296	15	8	88

**Table 1-1.** Los Angeles Basin watershed model.—Continued

[ha-m, hectare-meter; mm, millimeter]

Water year	Potential evapotranspiration (mm)	Urban irrigation (mm)	Precipitation (mm)	Actual evapotranspiration (mm)	Direct recharge (mm)	Storage change (mm)	Surface-water discharge (mm)
1977	1,246	63	389	358	17	-15	92
1978	1,224	63	1,110	482	146	59	485
1979	1,239	63	620	437	83	-19	182
1980	1,229	63	888	450	118	13	371
1981	1,291	63	304	321	27	-32	51
1982	1,221	63	498	395	31	8	127
1983	1,196	63	1,075	543	124	65	407
1984	1,303	63	291	346	38	-74	44
1985	1,254	63	371	321	30	-7	90
1986	1,245	63	612	419	54	25	177
1987	1,263	63	208	267	15	-33	23
1988	1,254	63	476	400	28	1	110
1989	1,268	63	325	303	25	-6	67
1990	1,278	63	262	274	11	-7	47
1991	1,245	63	416	316	26	3	134
1992	1,268	63	680	422	69	14	238
1993	1,239	63	994	482	133	33	410
1994	1,265	63	302	332	23	-30	40
1995	1,219	63	862	474	95	29	327
1996	1,287	63	390	339	34	-23	104
1997	1,290	63	453	345	52	-1	120
1998	1,187	63	997	526	128	50	356
1999	1,229	63	258	319	25	-46	24
2000	1,276	63	370	325	27	-9	90
2001	1,240	63	482	362	45	1	137
2002	1,270	63	156	211	11	-16	15
2003	1,263	63	529	413	26	7	147
2004	1,285	63	313	298	20	-8	66
2005	1,211	63	1,121	501	142	53	488
2006	1,258	63	414	393	31	-29	82
2007	1,285	63	135	205	10	-23	7

Table 1-1. Los Angeles Basin watershed model.—Continued

[ha-m, hectare-meter; mm, millimeter]

Water year	Potential evapotranspiration (mm)	Urban irrigation (mm)	Precipitation (mm)	Actual evapotranspiration (mm)	Direct recharge (mm)	Storage change (mm)	Surface-water discharge (mm)
2008	1,278	63	418	328	32	1	121
2009	1,287	63	297	283	20	-4	62
2010	1,238	63	511	383	42	9	141
2011	1,228	63	631	429	58	10	198
2012	1,273	63	294	315	14	-12	41
2013	1,289	63	219	246	10	-9	35
2014	1,318	63	191	218	7	-8	37
100-year							
Average	1,237	63	488	361	45	-1	146
Maximum	1,318	63	1,121	543	168	65	488
Minimum	1,167	63	135	205	7	-74	7
Variance	1,004	0	51,383	5,114	1,202	475	12,851
100-year							
Water year	Potential evapotranspiration (ha-m)	Urban irrigation (ha-m)	Precipitation (ha-m)	Actual evapotranspiration (ha-m)	Direct recharge (ha-m)	Storage change (ha-m)	Surface-water discharge (ha-m)
1915	595,376	31,887	324,084	220,197	37,926	1,236	96,611
1916	601,064	31,887	356,383	201,934	46,859	6,880	132,598
1917	588,885	31,887	259,404	207,163	28,012	-10,084	66,200
1918	611,087	31,887	251,609	174,534	25,185	721	83,056
1919	605,738	31,887	188,405	165,508	11,875	10,113	32,796
1920	603,567	31,887	241,062	211,326	19,370	-18,608	60,862
1921	595,613	31,887	263,945	215,228	16,475	3,902	60,226
1922	609,042	31,887	392,307	218,883	48,456	2,562	154,292
1923	603,815	31,887	203,873	183,198	17,692	-6,186	41,056
1924	617,761	31,887	142,595	150,159	7,797	-6,330	22,855
1925	607,560	31,887	165,776	167,301	6,009	-3,189	27,541
1926	616,659	31,887	293,111	210,263	17,796	2,781	94,159
1927	610,233	31,887	308,920	199,408	30,364	3,934	107,101
1928	623,015	31,887	189,689	176,172	13,685	-4,239	35,958
1929	617,895	31,887	194,830	179,751	11,255	-1,610	37,320



**Table 1-1.** Los Angeles Basin watershed model.—Continued

[ha-m, hectare-meter; mm, millimeter]

Water year	Potential evapotranspiration (ha-m)	Urban irrigation (ha-m)	Precipitation (ha-m)	Actual evapotranspiration (ha-m)	Direct recharge (ha-m)	Storage change (ha-m)	Surface-water discharge (ha-m)
1930	624,679	31,887	205,315	173,775	14,624	-185	48,988
1931	636,668	31,887	215,011	187,105	13,761	-998	47,030
1932	606,608	31,887	308,147	195,327	35,881	5,182	103,644
1933	606,898	31,887	186,520	150,831	17,490	-3,499	53,584
1934	643,253	31,887	224,440	157,861	14,177	-1,602	85,891
1935	607,633	31,887	341,154	235,179	30,941	7,275	99,644
1936	628,627	31,887	206,566	172,202	18,559	-5,038	52,730
1937	607,004	31,887	391,305	228,901	47,179	9,361	137,751
1938	614,001	31,887	395,315	210,399	47,664	4,089	165,049
1939	619,485	31,887	282,721	178,244	24,997	17,193	94,173
1940	629,176	31,887	221,031	204,336	21,059	-24,224	51,747
1941	593,592	31,887	550,528	258,775	84,748	23,936	214,956
1942	609,817	31,887	192,488	194,953	19,469	-18,845	28,798
1943	622,744	31,887	362,172	206,518	32,164	1,564	153,813
1944	605,293	31,887	327,828	200,378	39,701	2,301	117,335
1945	612,363	31,887	234,572	190,769	21,739	-5,031	58,982
1946	624,691	31,887	212,279	174,236	13,605	-4,398	60,723
1947	624,232	31,887	238,810	178,129	21,305	-1,676	72,939
1948	615,511	31,887	129,581	142,080	6,322	-5,439	18,504
1949	611,661	31,887	142,673	141,431	8,030	-2,373	27,472
1950	620,672	31,887	173,470	160,105	10,557	-961	35,656
1951	625,341	31,887	124,861	136,866	4,676	-2,906	18,111
1952	607,651	31,887	418,230	230,243	40,069	16,634	163,171
1953	618,394	31,887	156,346	156,267	15,098	-9,512	26,380
1954	627,033	31,887	197,539	170,401	12,886	-1,644	47,783
1955	616,940	31,887	183,743	172,160	10,239	-1,209	34,440
1956	621,902	31,887	223,688	175,778	10,639	71	69,086
1957	625,004	31,887	177,816	166,791	9,543	-1,791	35,159
1958	611,149	31,887	402,692	242,085	41,666	10,838	139,990
1959	653,530	31,887	121,166	134,209	10,690	-11,736	19,889
1960	645,797	31,887	139,137	140,632	7,674	-1,791	24,509

Table 1-1. Los Angeles Basin watershed model.—Continued

[ha-m, hectare-meter; mm, millimeter]

Water year	Potential evapotranspiration (ha-m)	Urban irrigation (ha-m)	Precipitation (ha-m)	Actual evapotranspiration (ha-m)	Direct recharge (ha-m)	Storage change (ha-m)	Surface-water discharge (ha-m)
1961	636,120	31,887	91,821	110,625	4,208	-4,171	13,045
1962	615,191	31,887	302,886	186,944	26,344	9,430	112,055
1963	616,873	31,887	171,247	161,520	7,358	1,143	33,112
1964	622,044	31,887	137,299	149,018	5,684	-7,956	22,440
1965	608,224	31,887	217,106	182,487	11,399	1,888	53,219
1966	635,684	31,887	310,514	176,944	30,851	2,892	131,714
1967	614,791	31,887	350,339	230,049	26,682	7,773	117,721
1968	640,206	31,887	201,495	172,326	18,070	-7,122	50,108
1969	616,811	31,887	469,566	212,780	51,564	14,009	223,101
1970	639,260	31,887	150,222	152,043	11,773	-13,259	31,551
1971	630,312	31,887	204,227	157,212	14,939	-980	64,944
1972	642,818	31,887	122,039	117,294	9,508	-4,320	31,444
1973	614,925	31,887	307,615	202,324	28,762	7,347	101,068
1974	632,310	31,887	228,811	173,781	20,439	-1,658	68,135
1975	610,302	31,887	213,920	184,794	13,908	-80	47,184
1976	625,892	31,887	173,238	149,134	7,634	3,937	44,419
1977	628,614	31,887	196,449	180,721	8,489	-7,405	46,530
1978	617,718	31,887	559,923	243,378	73,712	29,907	244,813
1979	625,263	31,887	312,667	220,373	41,653	-9,442	91,969
1980	619,898	31,887	448,200	227,009	59,368	6,731	186,978
1981	651,351	31,887	153,610	162,206	13,551	-16,155	25,894
1982	616,187	31,887	251,221	199,431	15,714	4,067	63,896
1983	603,416	31,887	542,327	273,827	62,389	32,633	205,364
1984	657,670	31,887	146,621	174,637	19,414	-37,553	22,010
1985	632,754	31,887	187,211	162,089	15,002	-3,352	45,359
1986	628,093	31,887	308,775	211,167	27,323	12,659	89,513
1987	637,488	31,887	104,994	134,563	7,434	-16,721	11,604
1988	632,638	31,887	239,992	202,015	13,918	287	55,659
1989	639,681	31,887	164,080	152,829	12,390	-3,259	34,006
1990	644,747	31,887	132,420	138,305	5,629	-3,487	23,860
1991	628,404	31,887	209,859	159,325	13,319	1,465	67,638

**Table 1-1.** Los Angeles Basin watershed model.—Continued

[ha-m, hectare-meter; mm, millimeter]

Water year	Potential evapotranspiration (ha-m)	Urban irrigation (ha-m)	Precipitation (ha-m)	Actual evapotranspiration (ha-m)	Direct recharge (ha-m)	Storage change (ha-m)	Surface-water discharge (ha-m)
1992	640,002	31,887	343,313	212,863	35,039	7,311	119,987
1993	625,348	31,887	501,457	242,944	66,924	16,564	206,912
1994	638,484	31,887	152,159	167,291	11,656	-15,128	20,228
1995	615,055	31,887	435,132	239,198	48,167	14,704	164,949
1996	649,549	31,887	196,984	170,896	17,253	-11,720	52,442
1997	650,959	31,887	228,703	174,072	26,465	-306	60,359
1998	599,110	31,887	503,048	265,609	64,614	25,286	179,426
1999	619,916	31,887	130,384	161,087	12,747	-23,457	11,894
2000	644,023	31,887	186,516	163,775	13,474	-4,458	45,612
2001	625,596	31,887	242,971	182,407	22,516	719	69,216
2002	640,674	31,887	78,895	106,283	5,354	-8,200	7,344
2003	637,226	31,887	267,105	208,210	13,348	3,503	73,930
2004	648,494	31,887	157,975	150,576	9,965	-3,861	33,182
2005	611,019	31,887	565,613	252,727	71,826	26,709	246,239
2006	634,676	31,887	209,067	198,506	15,816	-14,571	41,202
2007	648,165	31,887	68,085	103,236	5,059	-11,686	3,363
2008	644,780	31,887	211,066	165,742	15,964	324	60,923
2009	649,522	31,887	149,813	142,592	9,884	-2,151	31,374
2010	624,442	31,887	258,006	193,412	21,041	4,433	71,007
2011	619,473	31,887	318,577	216,257	29,224	4,875	100,108
2012	642,243	31,887	148,458	158,710	7,291	-6,136	20,481
2013	650,317	31,887	110,489	123,950	5,014	-4,478	17,889
2014	664,926	31,887	96,497	110,051	3,483	-3,992	18,842
100-year							
Average	624,143	31,887	246,341	182,195	22,565	-310	73,778
Maximum	664,926	31,887	565,613	273,827	84,748	32,633	246,239
Minimum	588,885	31,887	68,085	103,236	3,483	-37,553	3,363
Variance	255,701,870	0	13,080,443,302	1,301,738,559	305,866,837	121,028,587	3,271,432,068

## **Appendix 2**

---



**Table 2-1.** Los Angeles recharge study area.

[ha-m, hectare-meter; mm, millimeter]

Water year	Potential evapotranspiration (mm)	Urban irrigation (mm)	Precipitation (mm)	Actual evapotranspiration (mm)	Direct recharge (mm)	Storage change (mm)	Surface-water discharge (mm)
1915	1,206	120	478	348	76	5	169
1916	1,206	120	548	340	104	13	211
1917	1,193	120	368	327	54	-18	124
1918	1,233	120	355	304	47	-1	125
1919	1,222	120	263	282	21	-2	82
1920	1,220	120	330	331	36	-23	105
1921	1,203	120	382	335	30	8	129
1922	1,229	120	522	348	97	8	189
1923	1,222	120	287	303	29	-15	90
1924	1,245	120	203	269	13	-20	60
1925	1,229	120	216	273	9	-12	65
1926	1,247	120	389	333	33	7	137
1927	1,231	120	437	327	57	11	161
1928	1,253	120	275	298	22	-11	87
1929	1,244	120	280	296	18	-5	91
1930	1,259	120	302	297	26	-1	101
1931	1,287	120	308	305	24	-3	102
1932	1,226	120	431	317	70	12	152
1933	1,220	120	277	276	30	-5	96
1934	1,288	120	313	283	24	-5	132
1935	1,224	120	493	364	60	17	174
1936	1,260	120	292	295	33	-11	96
1937	1,223	120	567	361	94	24	208
1938	1,234	120	548	344	94	15	215
1939	1,246	120	433	305	45	21	182
1940	1,263	120	345	341	42	-36	117
1941	1,204	120	821	400	181	55	305
1942	1,231	120	288	327	33	-39	88
1943	1,254	120	468	338	61	3	186
1944	1,225	120	475	331	82	7	175
1945	1,235	120	335	318	40	-14	111

Table 2-1 Los Angeles recharge study area.—Continued

[ha-m, hectare-meter; mm, millimeter]

Water year	Potential evapotranspiration (mm)	Urban irrigation (mm)	Precipitation (mm)	Actual evapotranspiration (mm)	Direct recharge (mm)	Storage change (mm)	Surface-water discharge (mm)
1946	1,256	120	290	298	23	-14	103
1947	1,260	120	330	299	39	-5	117
1948	1,239	120	172	251	9	-19	51
1949	1,237	120	207	258	13	-8	64
1950	1,244	120	256	278	17	-4	84
1951	1,253	120	194	258	8	-10	59
1952	1,229	120	599	362	75	45	237
1953	1,244	120	241	283	25	-22	76
1954	1,261	120	302	300	24	-5	103
1955	1,243	120	269	291	17	-4	85
1956	1,250	120	351	309	20	1	141
1957	1,264	120	244	275	16	-7	79
1958	1,239	120	572	378	81	26	207
1959	1,317	120	165	249	13	-29	53
1960	1,294	120	226	267	12	-5	73
1961	1,278	120	125	219	6	-16	36
1962	1,236	120	459	322	50	31	175
1963	1,247	120	266	290	11	-6	91
1964	1,257	120	184	254	9	-16	56
1965	1,231	120	314	303	22	5	104
1966	1,282	120	421	310	59	8	163
1967	1,251	120	469	354	45	18	172
1968	1,294	120	317	302	30	-15	120
1969	1,247	120	637	354	105	39	260
1970	1,289	120	200	279	17	-37	61
1971	1,277	120	296	281	23	-2	113
1972	1,297	120	177	238	14	-15	60
1973	1,244	120	461	339	56	22	164
1974	1,273	120	348	308	37	-3	127
1975	1,235	120	329	309	25	0	115

**Table 2-1** Los Angeles recharge study area.—Continued

[ha-m, hectare-meter; mm, millimeter]

Water year	Potential evapotranspiration (mm)	Urban irrigation (mm)	Precipitation (mm)	Actual evapotranspiration (mm)	Direct recharge (mm)	Storage change (mm)	Surface-water discharge (mm)
1976	1,269	120	219	257	10	-3	74
1977	1,272	120	289	302	13	-9	105
1978	1,248	120	816	386	151	78	321
1979	1,264	120	472	361	81	-16	166
1980	1,258	120	653	367	124	22	260
1981	1,313	120	227	299	22	-44	71
1982	1,253	120	333	323	25	-4	109
1983	1,232	120	764	409	120	64	291
1984	1,327	120	221	308	31	-65	68
1985	1,277	120	274	291	24	-10	89
1986	1,266	120	489	348	54	27	180
1987	1,288	120	149	255	11	-40	42
1988	1,281	120	300	307	18	-3	98
1989	1,288	120	221	265	17	-10	69
1990	1,306	120	186	251	6	-12	61
1991	1,269	120	298	286	21	5	107
1992	1,300	120	477	343	63	18	173
1993	1,268	120	717	382	127	50	278
1994	1,291	120	228	299	17	-37	69
1995	1,246	120	655	379	99	41	256
1996	1,304	120	280	307	30	-30	94
1997	1,312	120	360	310	53	-7	124
1998	1,228	120	797	410	142	65	301
1999	1,252	120	201	291	21	-50	58
2000	1,297	120	264	290	23	-16	87
2001	1,258	120	384	317	44	3	141
2002	1,283	120	109	220	8	-29	29
2003	1,281	120	390	334	20	11	145
2004	1,306	120	229	270	16	-12	75
2005	1,237	120	813	402	134	74	323
2006	1,282	120	279	323	23	-35	88

Table 2-1 Los Angeles recharge study area.—Continued

[ha-m, hectare-meter; mm, millimeter]

Water year	Potential evapotranspiration (mm)	Urban irrigation (mm)	Precipitation (mm)	Actual evapotranspiration (mm)	Direct recharge (mm)	Storage change (mm)	Surface-water discharge (mm)
2007	1,304	120	80	216	7	-42	21
2008	1,299	120	305	289	26	5	105
2009	1,306	120	221	263	14	-7	72
2010	1,260	120	404	328	40	14	143
2011	1,249	120	485	356	59	16	174
2012	1,285	120	218	279	12	-19	65
2013	1,303	120	161	240	8	-15	48
2014	1,335	120	133	221	4	-15	43
100-year							
Average	1,259	120	356	308	42	-1	126
Maximum	1,335	120	821	410	181	78	323
Minimum	1,193	120	80	216	4	-65	21
Variance	930	0	27,866	1,849	1,371	661	4,804
Water year	Potential evapotranspiration (ha-m)	Urban irrigation (ha-m)	Precipitation (ha-m)	Actual evapotranspiration (ha-m)	Recharge (ha-m)	Storage change (ha-m)	Surface-water discharge (ha-m)
1915	227,348	22,642	90,083	65,612	14,419	874	31,820
1916	227,364	22,642	103,321	64,079	19,622	2,436	39,825
1917	224,955	22,642	69,306	61,698	10,269	-3,426	23,407
1918	232,489	22,642	66,927	57,373	8,887	-264	23,573
1919	230,352	22,642	49,679	53,261	3,901	-329	15,487
1920	229,985	22,642	62,154	62,479	6,785	-4,307	19,839
1921	226,921	22,642	71,996	63,198	5,632	1,457	24,351
1922	231,758	22,642	98,416	65,633	18,248	1,518	35,658
1923	230,388	22,642	54,098	57,110	5,524	-2,796	16,900
1924	234,807	22,642	38,227	50,822	2,358	-3,700	11,389
1925	231,714	22,642	40,663	51,455	1,787	-2,214	12,276
1926	235,249	22,642	73,364	62,732	6,140	1,233	25,901
1927	232,085	22,642	82,334	61,746	10,760	2,057	30,413
1928	236,262	22,642	51,899	56,145	4,135	-2,154	16,415



**Table 2-1** Los Angeles recharge study area.—Continued

[ha-m, hectare-meter; mm, millimeter]

Water year	Potential evapotranspiration (ha-m)	Urban irrigation (ha-m)	Precipitation (ha-m)	Actual evapotranspiration (ha-m)	Recharge (ha-m)	Storage change (ha-m)	Surface-water discharge (ha-m)
1929	234,595	22,642	52,823	55,823	3,439	-979	17,181
1930	237,508	22,642	56,977	55,997	4,855	-202	18,968
1931	242,669	22,642	58,147	57,555	4,448	-540	19,326
1932	231,109	22,642	81,201	59,820	13,171	2,236	28,616
1933	230,151	22,642	52,158	51,983	5,572	-939	18,184
1934	242,951	22,642	59,012	53,345	4,446	-978	24,841
1935	230,894	22,642	93,055	68,562	11,225	3,169	32,742
1936	237,529	22,642	55,139	55,594	6,131	-1,983	18,040
1937	230,561	22,642	106,865	68,077	17,695	4,549	39,186
1938	232,753	22,642	103,398	64,942	17,774	2,776	40,547
1939	235,027	22,642	81,645	57,550	8,416	3,952	34,369
1940	238,090	22,642	65,037	64,328	8,002	-6,752	22,101
1941	226,973	22,642	154,827	75,426	34,082	10,465	57,495
1942	232,098	22,642	54,378	61,629	6,199	-7,402	16,594
1943	236,439	22,642	88,185	63,662	11,533	483	35,149
1944	230,926	22,642	89,515	62,415	15,437	1,351	32,954
1945	232,856	22,642	63,226	60,000	7,527	-2,610	20,951
1946	236,826	22,642	54,625	56,196	4,267	-2,582	19,386
1947	237,561	22,642	62,161	56,357	7,424	-1,010	22,031
1948	233,641	22,642	32,476	47,408	1,656	-3,579	9,633
1949	233,194	22,642	39,083	48,647	2,477	-1,545	12,146
1950	234,679	22,642	48,246	52,439	3,256	-712	15,905
1951	236,209	22,642	36,622	48,579	1,482	-1,854	11,057
1952	231,788	22,642	113,038	68,266	14,218	8,531	44,665
1953	234,674	22,642	45,514	53,378	4,629	-4,162	14,311
1954	237,758	22,642	56,963	56,606	4,496	-886	19,388
1955	234,356	22,642	50,810	54,864	3,236	-759	16,111
1956	235,787	22,642	66,284	58,194	3,842	218	26,673
1957	238,356	22,642	45,921	51,941	2,966	-1,289	14,944
1958	233,722	22,642	107,837	71,352	15,211	4,849	39,067
1959	248,411	22,642	31,152	46,946	2,443	-5,550	9,954

Table 2-1 Los Angeles recharge study area.—Continued

[ha-m, hectare-meter; mm, millimeter]

Water year	Potential evapotranspiration (ha-m)	Urban irrigation (ha-m)	Precipitation (ha-m)	Actual evapotranspiration (ha-m)	Recharge (ha-m)	Storage change (ha-m)	Surface-water discharge (ha-m)
1960	244,095	22,642	42,679	50,399	2,195	-957	13,684
1961	240,988	22,642	23,646	41,352	1,038	-2,938	6,835
1962	233,072	22,642	86,465	60,772	9,453	5,931	32,951
1963	235,129	22,642	50,158	54,705	2,082	-1,174	17,188
1964	237,133	22,642	34,692	47,940	1,752	-2,965	10,607
1965	232,166	22,642	59,167	57,140	4,068	998	19,604
1966	241,702	22,642	79,352	58,476	11,100	1,588	30,830
1967	235,854	22,642	88,357	66,704	8,393	3,435	32,467
1968	243,982	22,642	59,747	57,030	5,596	-2,810	22,574
1969	235,205	22,642	120,218	66,809	19,743	7,298	49,009
1970	243,169	22,642	37,730	52,552	3,245	-6,900	11,475
1971	240,757	22,642	55,772	53,044	4,328	-358	21,399
1972	244,618	22,642	33,441	44,844	2,623	-2,762	11,377
1973	234,509	22,642	86,863	63,846	10,626	4,157	30,876
1974	240,004	22,642	65,718	58,036	7,031	-574	23,866
1975	232,885	22,642	62,059	58,345	4,635	71	21,650
1976	239,313	22,642	41,219	48,514	1,908	-473	13,912
1977	239,873	22,642	54,551	56,867	2,390	-1,791	19,726
1978	235,420	22,642	153,905	72,789	28,566	14,735	60,457
1979	238,322	22,642	88,965	68,036	15,298	-2,967	31,240
1980	237,186	22,642	123,093	69,206	23,354	4,159	49,017
1981	247,589	22,642	42,864	56,432	4,115	-8,390	13,348
1982	236,358	22,642	62,816	60,988	4,686	-805	20,589
1983	232,396	22,642	144,018	77,129	22,607	12,040	54,884
1984	250,241	22,642	41,690	58,003	5,846	-12,306	12,789
1985	240,743	22,642	51,756	54,964	4,502	-1,936	16,868
1986	238,808	22,642	92,143	65,694	10,122	5,002	33,968
1987	242,914	22,642	28,007	48,081	2,094	-7,531	8,005
1988	241,574	22,642	56,520	57,849	3,391	-505	18,426
1989	242,821	22,642	41,681	49,980	3,271	-1,977	13,048
1990	246,214	22,642	35,005	47,258	1,060	-2,216	11,546

**Table 2-1** Los Angeles recharge study area.—Continued

[ha-m, hectare-meter; mm, millimeter]

Water year	Potential evapotranspiration (ha-m)	Urban irrigation (ha-m)	Precipitation (ha-m)	Actual evapotranspiration (ha-m)	Recharge (ha-m)	Storage change (ha-m)	Surface-water discharge (ha-m)
1991	239,260	22,642	56,152	53,931	3,902	874	20,087
1992	245,087	22,642	89,979	64,673	11,954	3,403	32,592
1993	239,211	22,642	135,247	72,051	23,988	9,473	52,377
1994	243,484	22,642	43,078	56,353	3,272	-6,945	13,040
1995	235,048	22,642	123,606	71,479	18,744	7,711	48,314
1996	245,839	22,642	52,834	57,852	5,714	-5,733	17,642
1997	247,436	22,642	67,900	58,376	10,014	-1,279	23,430
1998	231,519	22,642	150,370	77,290	26,722	12,183	56,816
1999	236,018	22,642	37,823	54,967	3,988	-9,471	10,980
2000	244,501	22,642	49,825	54,646	4,376	-3,007	16,452
2001	237,167	22,642	72,461	59,714	8,254	536	26,598
2002	242,040	22,642	20,507	41,519	1,537	-5,400	5,493
2003	241,621	22,642	73,468	62,972	3,841	2,021	27,276
2004	246,217	22,642	43,186	50,956	3,047	-2,356	14,182
2005	233,250	22,642	153,313	75,832	25,306	13,991	60,825
2006	241,732	22,642	52,703	60,980	4,423	-6,689	16,631
2007	245,912	22,642	15,148	40,641	1,270	-7,994	3,873
2008	244,973	22,642	57,469	54,473	4,811	1,011	19,816
2009	246,265	22,642	41,766	49,574	2,655	-1,330	13,508
2010	237,539	22,642	76,278	61,914	7,496	2,637	26,873
2011	235,562	22,642	91,411	67,201	11,173	2,933	32,745
2012	242,329	22,642	41,076	52,607	2,260	-3,491	12,342
2013	245,743	22,642	30,389	45,252	1,578	-2,822	9,022
2014	251,830	22,642	25,057	41,647	782	-2,799	8,068
100-year							
Average	237,464	22,642	67,041	58,119	7,922	-188	23,830
Maximum	251,830	22,642	154,827	77,290	34,082	14,735	60,825
Minimum	224,955	22,642	15,148	40,641	782	-12,306	3,873
Variance	33,073,903	0	990,971,980	65,738,212	48,769,747	23,518,497	170,856,745

# Appendix 3

---



**Table 3-1.** Montebello Forebay.

[ha-m, hectare-meter; mm, millimeter]

Water year	Potential evapotranspiration (mm)	Urban irrigation (mm)	Precipitation (mm)	Actual evapotranspiration (mm)	Direct recharge (mm)	Storage change (mm)	Surface-water discharge (mm)
1915	1,231	133	439	345	70	-4	160
1916	1,236	133	553	348	109	11	217
1917	1,221	133	372	331	58	-20	136
1918	1,259	133	354	312	45	-1	131
1919	1,251	133	265	287	22	-5	94
1920	1,242	133	344	335	44	-24	121
1921	1,222	133	375	331	34	5	138
1922	1,247	133	576	359	108	21	220
1923	1,239	133	297	312	33	-21	105
1924	1,265	133	205	276	16	-26	72
1925	1,249	133	229	282	14	-14	80
1926	1,265	133	421	342	39	11	162
1927	1,251	133	460	338	62	14	179
1928	1,275	133	274	299	24	-16	99
1929	1,265	133	290	300	23	-7	106
1930	1,279	133	310	304	28	-1	113
1931	1,304	133	313	309	27	-4	114
1932	1,247	133	445	325	71	15	167
1933	1,246	133	285	285	29	-6	109
1934	1,314	133	342	305	26	-5	149
1935	1,245	133	492	360	61	20	184
1936	1,285	133	302	303	34	-12	110
1937	1,246	133	580	363	98	30	222
1938	1,258	133	574	355	102	20	230
1939	1,267	133	426	317	44	17	182
1940	1,284	133	332	342	40	-40	123
1941	1,219	133	821	395	182	65	312
1942	1,251	133	283	326	35	-46	101
1943	1,273	133	525	353	74	13	218
1944	1,243	133	478	336	84	6	184
1945	1,254	133	334	321	42	-20	123

Table 3-1. Montebello Forebay.—Continued

[ha-m, hectare-meter; mm, millimeter]

Water year	Potential evapotranspiration (mm)	Urban irrigation (mm)	Precipitation (mm)	Actual evapotranspiration (mm)	Direct recharge (mm)	Storage change (mm)	Surface-water discharge (mm)
1946	1,279	133	304	308	24	-17	122
1947	1,278	133	349	312	40	-5	134
1948	1,259	133	188	266	11	-23	67
1949	1,255	133	219	269	16	-11	77
1950	1,269	133	272	289	20	-5	101
1951	1,276	133	199	265	10	-14	70
1952	1,247	133	634	371	79	60	255
1953	1,264	133	247	295	26	-29	88
1954	1,281	133	314	308	27	-6	118
1955	1,263	133	271	293	20	-6	97
1956	1,273	133	352	314	22	0	149
1957	1,280	133	259	287	17	-7	94
1958	1,254	133	585	377	84	32	225
1959	1,337	133	170	263	12	-37	66
1960	1,318	133	225	272	11	-8	83
1961	1,301	133	124	227	6	-21	44
1962	1,258	133	456	328	44	39	178
1963	1,267	133	258	290	10	-8	99
1964	1,276	133	190	262	11	-19	69
1965	1,249	133	320	306	23	7	116
1966	1,301	133	432	323	57	12	172
1967	1,266	133	495	361	49	23	194
1968	1,312	133	293	304	27	-21	116
1969	1,266	133	666	364	108	53	274
1970	1,308	133	213	293	20	-44	77
1971	1,295	133	292	292	20	-5	118
1972	1,317	133	173	249	11	-21	66
1973	1,262	133	472	343	54	29	178
1974	1,295	133	361	319	38	-3	141
1975	1,254	133	327	309	26	-1	125
1976	1,284	133	241	273	12	1	88

Table 3-1. Montebello Forebay.—Continued

[ha-m, hectare-meter; mm, millimeter]

Water year	Potential evapotranspiration (mm)	Urban irrigation (mm)	Precipitation (mm)	Actual evapotranspiration (mm)	Direct recharge (mm)	Storage change (mm)	Surface-water discharge (mm)
1977	1,290	133	281	309	13	-15	107
1978	1,268	133	843	391	154	96	335
1979	1,293	133	475	366	80	-19	181
1980	1,282	133	655	371	121	28	268
1981	1,332	133	227	306	22	-53	83
1982	1,276	133	349	329	28	-3	128
1983	1,260	133	777	409	119	71	311
1984	1,352	133	213	314	31	-77	77
1985	1,302	133	303	306	28	-9	110
1986	1,294	133	483	351	49	27	187
1987	1,318	133	135	259	11	-51	49
1988	1,310	133	290	304	16	-4	107
1989	1,316	133	235	277	18	-12	84
1990	1,332	133	211	267	6	-12	82
1991	1,296	133	320	300	19	7	127
1992	1,328	133	451	344	54	17	169
1993	1,297	133	766	389	126	69	314
1994	1,318	133	221	306	17	-48	79
1995	1,276	133	655	385	93	49	260
1996	1,332	133	262	309	28	-40	97
1997	1,342	133	377	322	51	-5	142
1998	1,250	133	878	414	163	86	347
1999	1,282	133	195	302	24	-66	68
2000	1,332	133	268	302	21	-22	99
2001	1,298	133	315	303	26	-7	125
2002	1,315	133	127	236	8	-29	45
2003	1,309	133	503	365	37	30	204
2004	1,336	133	228	280	18	-23	84
2005	1,266	133	822	406	129	87	332
2006	1,315	133	238	313	21	-51	87
2007	1,335	133	60	218	7	-54	21

Table 3-1. Montebello Forebay.—Continued

[ha-m, hectare-meter; mm, millimeter]

Water year	Potential evapotranspiration (mm)	Urban irrigation (mm)	Precipitation (mm)	Actual evapotranspiration (mm)	Direct recharge (mm)	Storage change (mm)	Surface-water discharge (mm)		
2008	1,329	133	314	295	21	12	118		
2009	1,337	133	203	261	11	-13	76		
2010	1,288	133	421	333	34	20	167		
2011	1,274	133	502	359	60	22	194		
2012	1,310	133	221	287	14	-24	77		
2013	1,330	133	158	247	9	-20	55		
2014	1,358	133	142	236	4	-18	53		
100-year									
Average	1,283	133	363	315	43	-1	139		
Maximum	1,358	133	878	414	182	96	347		
Minimum	1,219	133	60	218	4	-77	21		
Variance	1,045	0	30,444	1,689	1,426	1,029	5,154		
Water year	Potential evapotranspiration (ha-m)	Urban irrigation (ha-m)	Precipitation (ha-m)	Actual evapotranspiration (ha-m)	Direct recharge (ha-m)	Storage change (ha-m)	Surface-water discharge (ha-m)	Potential mountain-front recharge (ha-m)	Total potential recharge (ha-m)
1915	15,404	1,659	5,486	4,315	870	-44	2,004	142	1,013
1916	15,466	1,659	6,912	4,351	1,359	141	2,720	220	1,579
1917	15,278	1,659	4,649	4,138	726	-256	1,700	81	808
1918	15,745	1,659	4,425	3,898	565	-14	1,635	105	670
1919	15,643	1,659	3,319	3,587	278	-63	1,175	15	293
1920	15,539	1,659	4,306	4,190	555	-296	1,516	52	607
1921	15,285	1,659	4,693	4,138	421	64	1,729	29	450
1922	15,594	1,659	7,203	4,489	1,350	266	2,757	273	1,624
1923	15,504	1,659	3,716	3,902	415	-259	1,318	33	448
1924	15,826	1,659	2,567	3,449	202	-322	897	8	209
1925	15,623	1,659	2,866	3,526	170	-175	1,003	9	179
1926	15,818	1,659	5,271	4,279	487	140	2,026	70	557
1927	15,646	1,659	5,759	4,230	781	175	2,233	157	938
1928	15,955	1,659	3,426	3,746	300	-203	1,242	22	322
1929	15,820	1,659	3,630	3,757	289	-86	1,330	19	307



Table 3-1. Montebello Forebay.—Continued

[ha-m, hectare-meter; mm, millimeter]

Water year	Potential evapotranspiration (ha-m)	Urban irrigation (ha-m)	Precipitation (ha-m)	Actual evapotranspiration (ha-m)	Direct recharge (ha-m)	Storage change (ha-m)	Surface-water discharge (ha-m)	Potential mountain-front recharge (ha-m)	Total potential recharge (ha-m)
1930	15,994	1,659	3,879	3,801	348	-18	1,408	34	382
1931	16,311	1,659	3,918	3,868	336	-54	1,427	26	362
1932	15,595	1,659	5,563	4,062	887	185	2,087	171	1,058
1933	15,588	1,659	3,566	3,569	362	-70	1,365	61	423
1934	16,435	1,659	4,283	3,811	328	-61	1,866	58	386
1935	15,580	1,659	6,150	4,505	763	245	2,296	125	888
1936	16,077	1,659	3,777	3,788	427	-156	1,377	53	480
1937	15,583	1,659	7,256	4,545	1,222	373	2,775	241	1,463
1938	15,738	1,659	7,185	4,442	1,273	247	2,883	241	1,514
1939	15,853	1,659	5,329	3,962	545	206	2,275	88	633
1940	16,067	1,659	4,155	4,276	503	-506	1,541	50	553
1941	15,247	1,659	10,271	4,944	2,276	807	3,903	427	2,703
1942	15,651	1,659	3,538	4,079	435	-582	1,266	27	462
1943	15,927	1,659	6,571	4,421	928	157	2,725	173	1,101
1944	15,551	1,659	5,980	4,205	1,051	81	2,303	178	1,229
1945	15,682	1,659	4,179	4,021	529	-249	1,537	48	577
1946	15,996	1,659	3,799	3,854	299	-217	1,522	22	321
1947	15,981	1,659	4,368	3,906	500	-57	1,679	96	596
1948	15,751	1,659	2,355	3,325	139	-288	838	5	145
1949	15,703	1,659	2,739	3,370	204	-136	961	13	217
1950	15,873	1,659	3,401	3,620	248	-68	1,261	26	274
1951	15,960	1,659	2,485	3,318	126	-169	870	5	131
1952	15,602	1,659	7,925	4,646	994	749	3,195	260	1,255
1953	15,817	1,659	3,085	3,686	324	-360	1,095	31	355
1954	16,029	1,659	3,929	3,853	338	-80	1,478	41	378
1955	15,805	1,659	3,384	3,661	248	-75	1,208	17	266
1956	15,928	1,659	4,401	3,925	271	4	1,860	22	294
1957	16,013	1,659	3,237	3,595	215	-92	1,178	12	228
1958	15,690	1,659	7,320	4,713	1,050	400	2,815	198	1,249
1959	16,725	1,659	2,131	3,288	147	-465	820	8	155
1960	16,493	1,659	2,810	3,406	135	-104	1,033	8	143

Table 3-1. Montebello Forebay.—Continued

[ha-m, hectare-meter; mm, millimeter]

Water year	Potential evapotranspiration (ha-m)	Urban irrigation (ha-m)	Precipitation (ha-m)	Actual evapotranspiration (ha-m)	Direct recharge (ha-m)	Storage change (ha-m)	Surface-water discharge (ha-m)	Potential mountain-front recharge (ha-m)	Total potential recharge (ha-m)
1961	16,270	1,659	1,548	2,844	72	-260	552	3	74
1962	15,737	1,659	5,705	4,105	546	491	2,222	177	723
1963	15,848	1,659	3,231	3,626	129	-103	1,237	7	137
1964	15,964	1,659	2,379	3,271	138	-232	862	7	144
1965	15,621	1,659	4,002	3,829	291	93	1,448	32	324
1966	16,275	1,659	5,398	4,046	716	146	2,148	181	897
1967	15,834	1,659	6,193	4,514	616	292	2,430	120	736
1968	16,415	1,659	3,670	3,803	333	-258	1,451	37	371
1969	15,836	1,659	8,326	4,551	1,351	660	3,423	323	1,674
1970	16,360	1,659	2,666	3,665	250	-556	966	17	267
1971	16,194	1,659	3,656	3,653	250	-59	1,471	48	298
1972	16,474	1,659	2,166	3,116	137	-258	831	17	154
1973	15,789	1,659	5,905	4,290	680	362	2,232	162	842
1974	16,201	1,659	4,515	3,985	472	-42	1,759	84	557
1975	15,690	1,659	4,084	3,862	321	-8	1,568	25	346
1976	16,064	1,659	3,015	3,411	145	12	1,105	7	153
1977	16,141	1,659	3,518	3,866	162	-193	1,342	9	171
1978	15,865	1,659	10,543	4,885	1,931	1,196	4,190	457	2,388
1979	16,178	1,659	5,942	4,573	1,004	-244	2,269	168	1,172
1980	16,040	1,659	8,188	4,637	1,516	348	3,346	319	1,835
1981	16,664	1,659	2,836	3,833	278	-657	1,041	17	295
1982	15,959	1,659	4,364	4,118	347	-42	1,600	31	378
1983	15,756	1,659	9,721	5,113	1,492	884	3,891	304	1,796
1984	16,917	1,659	2,666	3,934	393	-967	966	24	416
1985	16,292	1,659	3,795	3,834	352	-113	1,381	59	411
1986	16,189	1,659	6,036	4,393	613	344	2,345	114	727
1987	16,486	1,659	1,685	3,234	138	-638	610	6	143
1988	16,386	1,659	3,629	3,798	197	-50	1,342	19	217
1989	16,463	1,659	2,945	3,468	227	-145	1,055	29	256
1990	16,664	1,659	2,640	3,346	78	-156	1,030	4	82
1991	16,216	1,659	4,005	3,752	241	87	1,584	61	302

Table 3-1. Montebello Forebay.—Continued

[ha-m, hectare-meter; mm, millimeter]

Water year	Potential evapotranspiration (ha-m)	Urban irrigation (ha-m)	Precipitation (ha-m)	Actual evapotranspiration (ha-m)	Direct recharge (ha-m)	Storage change (ha-m)	Surface-water discharge (ha-m)	Potential mountain-front recharge (ha-m)	Total potential recharge (ha-m)
1992	16,617	1,659	5,647	4,301	682	211	2,113	156	838
1993	16,222	1,659	9,576	4,866	1,580	862	3,927	385	1,965
1994	16,491	1,659	2,770	3,831	207	-597	989	12	219
1995	15,965	1,659	8,192	4,817	1,158	619	3,258	229	1,387
1996	16,668	1,659	3,276	3,867	350	-501	1,219	40	390
1997	16,782	1,659	4,720	4,034	638	-63	1,771	97	734
1998	15,640	1,659	10,982	5,178	2,042	1,075	4,347	388	2,430
1999	16,039	1,659	2,439	3,776	303	-829	848	14	318
2000	16,661	1,659	3,348	3,783	263	-279	1,241	36	299
2001	16,236	1,659	3,935	3,792	330	-94	1,566	60	390
2002	16,448	1,659	1,587	2,953	96	-361	557	3	99
2003	16,379	1,659	6,295	4,562	461	379	2,552	90	551
2004	16,709	1,659	2,848	3,506	228	-283	1,057	19	246
2005	15,838	1,659	10,281	5,079	1,617	1,094	4,150	419	2,036
2006	16,453	1,659	2,979	3,921	261	-636	1,091	18	279
2007	16,703	1,659	745	2,724	85	-670	265	2	86
2008	16,623	1,659	3,929	3,695	261	154	1,478	52	313
2009	16,722	1,659	2,534	3,264	135	-158	952	15	150
2010	16,108	1,659	5,268	4,165	424	255	2,084	117	542
2011	15,942	1,659	6,284	4,491	745	278	2,428	157	902
2012	16,389	1,659	2,759	3,588	177	-306	958	8	185
2013	16,640	1,659	1,973	3,084	117	-255	686	5	122
2014	16,985	1,659	1,782	2,954	49	-226	665	2	51
100-year									
Average	16,044	1,659	4,543	3,940	538	-17	1,740	92	630
Maximum	16,985	1,659	10,982	5,178	2,276	1,196	4,347	457	2,703
Minimum	15,247	1,659	745	2,724	49	-967	265	2	51
Variance	163,470	0	4,763,921	264,338	223,088	160,945	806,518	12,090	335,998

Table 3-2. Central Basin Pressure.

[ha-m, hectare-meter; mm, millimeter]

Water year	Potential evapotranspiration (mm)	Urban irrigation (mm)	Precipitation (mm)	Actual evapotranspiration (mm)	Direct recharge (mm)	Storage change (mm)	Surface-water discharge (mm)
1915	1,213	149	428	326	66	3	183
1916	1,213	149	512	324	93	15	229
1917	1,202	149	347	311	58	-20	147
1918	1,237	149	319	294	39	-2	137
1919	1,227	149	241	275	24	-8	100
1920	1,221	149	307	311	40	-22	126
1921	1,203	149	353	311	34	6	151
1922	1,227	149	493	330	82	14	216
1923	1,222	149	270	292	32	-17	112
1924	1,245	149	189	268	17	-25	78
1925	1,229	149	203	270	14	-15	83
1926	1,248	149	363	312	33	6	160
1927	1,231	149	401	311	48	12	179
1928	1,252	149	255	285	25	-13	108
1929	1,243	149	260	283	22	-7	111
1930	1,259	149	287	290	27	-2	121
1931	1,286	149	289	295	26	-5	123
1932	1,226	149	410	305	63	15	176
1933	1,219	149	262	275	27	-5	114
1934	1,287	149	292	285	22	-6	141
1935	1,223	149	467	336	59	20	202
1936	1,259	149	278	288	34	-12	117
1937	1,223	149	536	337	82	29	236
1938	1,233	149	515	328	82	19	234
1939	1,245	149	407	298	41	21	196
1940	1,261	149	322	328	44	-39	136
1941	1,201	149	767	362	156	65	332
1942	1,230	149	271	313	38	-44	113
1943	1,252	149	448	326	58	6	207
1944	1,223	149	449	316	75	9	198
1945	1,233	149	321	306	45	-17	136



Table 3-2. Central Basin Pressure.—Continued

[ha-m, hectare-meter; mm, millimeter]

Water year	Potential evapotranspiration (mm)	Urban irrigation (mm)	Precipitation (mm)	Actual evapotranspiration (mm)	Direct recharge (mm)	Storage change (mm)	Surface-water discharge (mm)
1946	1,256	149	274	292	25	-17	123
1947	1,259	149	313	293	37	-6	138
1948	1,238	149	164	256	12	-23	68
1949	1,233	149	195	259	17	-12	80
1950	1,240	149	247	276	20	-6	105
1951	1,250	149	182	259	11	-15	75
1952	1,231	149	552	339	60	51	251
1953	1,246	149	229	280	26	-24	95
1954	1,257	149	279	288	25	-6	121
1955	1,240	149	249	279	21	-5	104
1956	1,249	149	330	298	22	1	157
1957	1,260	149	225	270	18	-9	95
1958	1,238	149	541	349	73	31	237
1959	1,316	149	151	256	13	-35	67
1960	1,295	149	215	267	13	-7	91
1961	1,277	149	112	229	7	-22	47
1962	1,235	149	421	309	36	37	188
1963	1,248	149	253	284	12	-6	111
1964	1,254	149	170	254	13	-19	72
1965	1,227	149	299	291	24	6	126
1966	1,282	149	394	306	48	10	178
1967	1,253	149	436	328	39	21	197
1968	1,296	149	289	295	29	-17	132
1969	1,247	149	591	337	83	47	273
1970	1,291	149	186	279	20	-42	78
1971	1,280	149	273	280	20	-2	124
1972	1,299	149	166	248	12	-19	73
1973	1,246	149	433	320	48	26	188
1974	1,274	149	330	300	35	-3	147
1975	1,239	149	325	300	29	2	143
1976	1,271	149	209	260	13	-3	88

Table 3-2. Central Basin Pressure.—Continued

[ha-m, hectare-meter; mm, millimeter]

Water year	Potential evapotranspiration (mm)	Urban irrigation (mm)	Precipitation (mm)	Actual evapotranspiration (mm)	Direct recharge (mm)	Storage change (mm)	Surface-water discharge (mm)
1977	1,275	149	262	295	14	-14	115
1978	1,252	149	768	360	121	93	344
1979	1,266	149	447	341	74	-15	195
1980	1,260	149	614	347	104	30	282
1981	1,314	149	213	299	24	-51	90
1982	1,256	149	309	306	27	-6	131
1983	1,236	149	709	370	101	71	317
1984	1,326	149	214	308	36	-71	90
1985	1,276	149	268	289	26	-12	113
1986	1,267	149	452	326	47	28	200
1987	1,288	149	144	265	15	-47	60
1988	1,283	149	270	290	19	-6	115
1989	1,289	149	205	266	18	-15	85
1990	1,308	149	174	255	7	-17	77
1991	1,269	149	280	283	16	5	125
1992	1,302	149	427	324	49	18	185
1993	1,270	149	666	356	95	61	302
1994	1,294	149	218	296	20	-40	92
1995	1,250	149	603	351	79	48	274
1996	1,305	149	261	300	30	-34	114
1997	1,313	149	341	303	48	-7	146
1998	1,235	149	756	373	119	76	337
1999	1,252	149	193	292	26	-55	79
2000	1,299	149	236	285	22	-22	101
2001	1,258	149	344	303	36	1	152
2002	1,283	149	96	231	10	-36	40
2003	1,279	149	353	311	18	12	161
2004	1,305	149	212	268	18	-16	91
2005	1,237	149	738	368	99	86	334
2006	1,281	149	257	309	25	-37	109
2007	1,304	149	75	236	9	-52	30

Table 3-2. Central Basin Pressure.—Continued

[ha-m, hectare-meter; mm, millimeter]

Water year	Potential evapotranspiration (mm)	Urban irrigation (mm)	Precipitation (mm)	Actual evapotranspiration (mm)	Direct recharge (mm)	Storage change (mm)	Surface-water discharge (mm)		
2008	1,297	149	302	289	23	10	129		
2009	1,304	149	216	266	16	-9	92		
2010	1,261	149	357	307	31	13	155		
2011	1,249	149	468	335	55	20	207		
2012	1,285	149	200	273	16	-23	82		
2013	1,303	149	153	247	11	-19	62		
2014	1,334	149	127	236	5	-20	55		
100-year									
Average	1,260	149	332	298	39	-1	145		
Maximum	1,334	149	768	373	156	93	344		
Minimum	1,201	149	75	229	5	-71	30		
Variance	910	0	24,125	1,021	861	891	5,087		
Water year	Potential evapotranspiration (ha-m)	Urban irrigation (ha-m)	Precipitation (ha-m)	Actual evapotranspiration (ha-m)	Direct recharge (ha-m)	Storage change (ha-m)	Surface-water discharge (ha-m)	Potential mountain-front recharge (ha-m)	Total potential recharge (ha-m)
1915	51,544	6,327	18,185	13,838	2,790	122	7,763	0	2,790
1916	51,507	6,327	21,740	13,747	3,954	644	9,721	0	3,954
1917	51,052	6,327	14,741	13,190	2,448	-834	6,264	0	2,448
1918	52,538	6,327	13,555	12,495	1,677	-93	5,802	0	1,677
1919	52,131	6,327	10,235	11,681	1,004	-356	4,233	0	1,004
1920	51,882	6,327	13,043	13,219	1,718	-937	5,369	0	1,718
1921	51,090	6,327	14,993	13,219	1,425	263	6,413	0	1,425
1922	52,132	6,327	20,928	14,036	3,481	584	9,155	0	3,481
1923	51,890	6,327	11,483	12,407	1,369	-712	4,746	0	1,369
1924	52,872	6,327	8,029	11,392	719	-1,049	3,293	0	719
1925	52,223	6,327	8,605	11,463	589	-648	3,529	0	589
1926	53,009	6,327	15,403	13,273	1,406	276	6,776	0	1,406
1927	52,280	6,327	17,033	13,210	2,051	491	7,607	0	2,051
1928	53,175	6,327	10,846	12,091	1,070	-571	4,582	0	1,070
1929	52,805	6,327	11,061	12,030	956	-294	4,696	0	956

Table 3-2. Central Basin Pressure.—Continued

[ha-m, hectare-meter; mm, millimeter]

Water year	Potential evapotranspiration (ha-m)	Urban irrigation (ha-m)	Precipitation (ha-m)	Actual evapotranspiration (ha-m)	Direct recharge (ha-m)	Storage change (ha-m)	Surface-water discharge (ha-m)	Potential mountain-front recharge (ha-m)	Total potential recharge (ha-m)
1930	53,464	6,327	12,199	12,307	1,159	-98	5,158	0	1,159
1931	54,618	6,327	12,290	12,517	1,095	-200	5,205	0	1,095
1932	52,059	6,327	17,413	12,955	2,671	633	7,481	0	2,671
1933	51,781	6,327	11,131	11,670	1,149	-192	4,831	0	1,149
1934	54,653	6,327	12,401	12,097	925	-269	5,975	0	925
1935	51,948	6,327	19,842	14,259	2,491	857	8,562	0	2,491
1936	53,461	6,327	11,798	12,251	1,437	-523	4,961	0	1,437
1937	51,943	6,327	22,752	14,329	3,500	1,232	10,018	0	3,500
1938	52,376	6,327	21,858	13,930	3,503	824	9,928	0	3,503
1939	52,877	6,327	17,304	12,667	1,747	887	8,330	0	1,747
1940	53,583	6,327	13,658	13,954	1,880	-1,640	5,791	0	1,880
1941	51,005	6,327	32,582	15,393	6,643	2,750	14,123	0	6,643
1942	52,226	6,327	11,497	13,302	1,610	-1,871	4,782	0	1,610
1943	53,192	6,327	19,021	13,858	2,470	239	8,781	0	2,470
1944	51,947	6,327	19,071	13,439	3,177	392	8,389	0	3,177
1945	52,380	6,327	13,642	12,991	1,893	-704	5,788	0	1,893
1946	53,360	6,327	11,650	12,391	1,081	-731	5,235	0	1,081
1947	53,468	6,327	13,316	12,457	1,562	-257	5,882	0	1,562
1948	52,602	6,327	6,969	10,872	515	-987	2,897	0	515
1949	52,390	6,327	8,303	11,019	709	-503	3,404	0	709
1950	52,677	6,327	10,493	11,734	841	-235	4,480	0	841
1951	53,087	6,327	7,721	11,022	483	-630	3,172	0	483
1952	52,290	6,327	23,462	14,402	2,561	2,160	10,666	0	2,561
1953	52,918	6,327	9,715	11,900	1,116	-1,005	4,031	0	1,116
1954	53,386	6,327	11,864	12,253	1,069	-256	5,124	0	1,069
1955	52,664	6,327	10,594	11,856	872	-224	4,416	0	872
1956	53,062	6,327	14,008	12,667	946	50	6,672	0	946
1957	53,539	6,327	9,548	11,471	744	-376	4,036	0	744
1958	52,573	6,327	22,982	14,827	3,097	1,306	10,078	0	3,097
1959	55,918	6,327	6,432	10,870	550	-1,500	2,838	0	550
1960	54,991	6,327	9,121	11,558	538	-297	3,849	0	538



Table 3-2. Central Basin Pressure.—Continued

[ha-m, hectare-meter; mm, millimeter]

Water year	Potential evapotranspiration (ha-m)	Urban irrigation (ha-m)	Precipitation (ha-m)	Actual evapotranspiration (ha-m)	Direct recharge (ha-m)	Storage change (ha-m)	Surface-water discharge (ha-m)	Potential mountain-front recharge (ha-m)	Total potential recharge (ha-m)
1961	54,239	6,327	4,753	9,741	296	-948	1,990	0	296
1962	52,458	6,327	17,883	13,113	1,537	1,567	7,992	0	1,537
1963	52,999	6,327	10,734	12,063	513	-234	4,718	0	513
1964	53,261	6,327	7,215	10,775	553	-824	3,038	0	553
1965	52,133	6,327	12,688	12,372	1,039	272	5,333	0	1,039
1966	54,456	6,327	16,727	12,990	2,056	429	7,579	0	2,056
1967	53,228	6,327	18,505	13,944	1,657	882	8,349	0	1,657
1968	55,066	6,327	12,262	12,514	1,231	-743	5,586	0	1,231
1969	52,971	6,327	25,116	14,323	3,528	1,992	11,600	0	3,528
1970	54,822	6,327	7,885	11,838	835	-1,782	3,320	0	835
1971	54,362	6,327	11,588	11,901	840	-86	5,260	0	840
1972	55,161	6,327	7,045	10,547	510	-803	3,118	0	510
1973	52,941	6,327	18,392	13,607	2,021	1,123	7,968	0	2,021
1974	54,100	6,327	14,038	12,758	1,479	-120	6,247	0	1,479
1975	52,612	6,327	13,796	12,733	1,225	70	6,095	0	1,225
1976	54,007	6,327	8,880	11,063	532	-141	3,754	0	532
1977	54,159	6,327	11,125	12,536	597	-576	4,894	0	597
1978	53,172	6,327	32,632	15,295	5,125	3,933	14,606	0	5,125
1979	53,759	6,327	18,983	14,494	3,144	-616	8,287	0	3,144
1980	53,504	6,327	26,080	14,756	4,403	1,262	11,986	0	4,403
1981	55,818	6,327	9,059	12,683	1,027	-2,159	3,834	0	1,027
1982	53,348	6,327	13,122	13,011	1,165	-272	5,544	0	1,165
1983	52,511	6,327	30,126	15,707	4,289	3,012	13,445	0	4,289
1984	56,304	6,327	9,104	13,075	1,544	-3,010	3,821	0	1,544
1985	54,194	6,327	11,368	12,293	1,090	-494	4,807	0	1,090
1986	53,830	6,327	19,194	13,864	1,982	1,191	8,483	0	1,982
1987	54,711	6,327	6,098	11,242	636	-1,984	2,531	0	636
1988	54,478	6,327	11,472	12,329	819	-235	4,886	0	819
1989	54,753	6,327	8,728	11,290	782	-642	3,624	0	782
1990	55,542	6,327	7,388	10,841	305	-701	3,270	0	305
1991	53,916	6,327	11,914	12,006	700	217	5,319	0	700

**Table 3-2. Central Basin Pressure.—Continued**

[ha-m, hectare-meter; mm, millimeter]

Water year	Potential evapotranspiration (ha-m)	Urban irrigation (ha-m)	Precipitation (ha-m)	Actual evapotranspiration (ha-m)	Direct recharge (ha-m)	Storage change (ha-m)	Surface-water discharge (ha-m)	Potential mountain-front recharge (ha-m)	Total potential recharge (ha-m)
1992	55,286	6,327	18,136	13,756	2,084	772	7,851	0	2,084
1993	53,947	6,327	28,280	15,115	4,054	2,608	12,831	0	4,054
1994	54,948	6,327	9,269	12,570	846	-1,708	3,887	0	846
1995	53,113	6,327	25,628	14,918	3,358	2,039	11,640	0	3,358
1996	55,433	6,327	11,070	12,758	1,271	-1,465	4,833	0	1,271
1997	55,784	6,327	14,472	12,880	2,021	-316	6,213	0	2,021
1998	52,473	6,327	32,102	15,839	5,053	3,236	14,301	0	5,053
1999	53,162	6,327	8,208	12,415	1,083	-2,328	3,364	0	1,083
2000	55,197	6,327	10,043	12,112	916	-934	4,276	0	916
2001	53,430	6,327	14,625	12,880	1,540	63	6,468	0	1,540
2002	54,509	6,327	4,077	9,830	415	-1,528	1,687	0	415
2003	54,323	6,327	14,980	13,195	771	502	6,839	0	771
2004	55,439	6,327	9,026	11,387	766	-667	3,867	0	766
2005	52,552	6,327	31,359	15,623	4,201	3,661	14,201	0	4,201
2006	54,423	6,327	10,929	13,139	1,069	-1,588	4,635	0	1,069
2007	55,395	6,327	3,178	10,043	366	-2,195	1,291	0	366
2008	55,083	6,327	12,844	12,294	973	417	5,488	0	973
2009	55,385	6,327	9,156	11,297	680	-395	3,901	0	680
2010	53,548	6,327	15,158	13,038	1,308	550	6,589	0	1,308
2011	53,047	6,327	19,875	14,249	2,327	844	8,781	0	2,327
2012	54,570	6,327	8,508	11,612	682	-960	3,501	0	682
2013	55,334	6,327	6,491	10,479	483	-797	2,653	0	483
2014	56,646	6,327	5,381	10,020	214	-861	2,336	0	214
100-year									
Average	53,504	6,327	14,112	12,675	1,646	-58	6,176	0	1,646
Maximum	56,646	6,327	32,632	15,839	6,643	3,933	14,606	0	6,643
Minimum	51,005	6,327	3,178	9,741	214	-3,010	1,291	0	214
Variance	1,641,194	0	43,528,837	1,842,375	1,553,904	1,607,613	9,179,221	0	1,553,904

**Table 3-3.** West Coast Basin.

[ha-m, hectare-meter; mm, millimeter]

Water year	Potential evapotranspiration (mm)	Urban irrigation (mm)	Precipitation (mm)	Actual evapotranspiration (mm)	Direct recharge (mm)	Storage change (mm)	Surface-water discharge (mm)
1915	1,191	116	464	300	69	9	201
1916	1,189	116	512	295	93	12	228
1917	1,178	116	347	278	53	-15	148
1918	1,217	116	310	261	36	-2	131
1919	1,205	116	230	237	20	-7	95
1920	1,209	116	283	269	32	-20	117
1921	1,190	116	349	276	29	8	151
1922	1,214	116	453	296	71	6	196
1923	1,208	116	271	256	29	-11	113
1924	1,230	116	184	229	13	-20	77
1925	1,218	116	189	228	11	-12	78
1926	1,237	116	317	267	27	3	136
1927	1,216	116	356	270	40	8	155
1928	1,235	116	248	246	21	-9	106
1929	1,229	116	239	242	17	-5	101
1930	1,245	116	277	252	23	-0	118
1931	1,273	116	273	255	21	-3	115
1932	1,207	116	380	268	54	11	162
1933	1,198	116	248	238	23	-3	106
1934	1,268	116	236	234	18	-9	108
1935	1,207	116	447	301	50	19	193
1936	1,238	116	256	248	27	-11	108
1937	1,203	116	498	303	69	22	220
1938	1,212	116	459	290	69	12	204
1939	1,223	116	395	256	32	31	192
1940	1,241	116	311	293	41	-40	132
1941	1,192	116	721	337	138	49	312
1942	1,213	116	261	271	31	-34	109
1943	1,236	116	386	283	46	-1	173
1944	1,212	116	415	282	61	6	183
1945	1,220	116	312	267	37	-11	134

**Table 3-3. West Coast Basin.—Continued**

[ha-m, hectare-meter; mm, millimeter]

Water year	Potential evapotranspiration (mm)	Urban irrigation (mm)	Precipitation (mm)	Actual evapotranspiration (mm)	Direct recharge (mm)	Storage change (mm)	Surface-water discharge (mm)
1946	1,240	116	252	249	21	-13	111
1947	1,246	116	295	254	31	-6	131
1948	1,225	116	137	207	8	-20	57
1949	1,223	116	191	221	12	-6	79
1950	1,227	116	233	236	16	-3	100
1951	1,236	116	175	219	8	-10	73
1952	1,214	116	496	301	53	38	219
1953	1,229	116	219	240	21	-18	92
1954	1,247	116	267	251	21	-4	115
1955	1,227	116	242	242	17	-3	102
1956	1,233	116	321	261	22	2	151
1957	1,251	116	210	230	15	-7	88
1958	1,232	116	512	315	64	25	224
1959	1,305	116	147	216	11	-28	64
1960	1,274	116	218	232	12	-3	92
1961	1,260	116	111	190	6	-16	47
1962	1,219	116	414	278	37	31	184
1963	1,234	116	264	253	12	-2	117
1964	1,242	116	158	214	11	-18	67
1965	1,218	116	282	253	20	5	119
1966	1,266	116	384	273	46	9	172
1967	1,239	116	398	288	33	16	176
1968	1,279	116	296	262	29	-14	135
1969	1,234	116	544	305	76	32	247
1970	1,274	116	168	231	15	-33	71
1971	1,264	116	268	244	18	1	121
1972	1,284	116	163	210	11	-14	72
1973	1,232	116	406	285	42	21	174
1974	1,258	116	306	260	30	-3	135
1975	1,224	116	296	258	23	0	130
1976	1,259	116	182	216	9	-4	77

Table 3-3. West Coast Basin.—Continued

[ha-m, hectare-meter; mm, millimeter]

Water year	Potential evapotranspiration (mm)	Urban irrigation (mm)	Precipitation (mm)	Actual evapotranspiration (mm)	Direct recharge (mm)	Storage change (mm)	Surface-water discharge (mm)
1977	1,257	116	284	265	14	-4	125
1978	1,236	116	716	333	114	69	315
1979	1,249	116	426	305	67	-14	185
1980	1,245	116	554	313	91	17	249
1981	1,296	116	208	254	20	-39	88
1982	1,241	116	303	268	24	-2	129
1983	1,217	116	674	339	94	61	296
1984	1,307	116	211	266	32	-60	89
1985	1,258	116	239	245	20	-11	101
1986	1,248	116	473	299	49	33	208
1987	1,271	116	134	224	12	-42	56
1988	1,266	116	269	255	18	-2	114
1989	1,268	116	191	225	15	-12	79
1990	1,289	116	149	209	6	-14	65
1991	1,248	116	260	243	14	5	114
1992	1,281	116	429	292	48	20	185
1993	1,251	116	623	326	93	44	276
1994	1,273	116	209	252	17	-33	88
1995	1,226	116	605	324	80	43	274
1996	1,284	116	244	260	27	-32	105
1997	1,291	116	335	269	44	-6	144
1998	1,212	116	723	344	116	62	317
1999	1,231	116	200	254	22	-44	83
2000	1,275	116	232	247	20	-17	98
2001	1,236	116	374	277	41	6	165
2002	1,262	116	96	194	9	-31	40
2003	1,260	116	317	268	16	8	141
2004	1,285	116	205	230	16	-13	88
2005	1,217	116	727	342	100	74	327
2006	1,259	116	255	272	23	-32	108



**Table 3-3. West Coast Basin.—Continued**

[ha-m, hectare-meter; mm, millimeter]

Water year	Potential evapotranspiration (mm)	Urban irrigation (mm)	Precipitation (mm)	Actual evapotranspiration (mm)	Direct recharge (mm)	Storage change (mm)	Surface-water discharge (mm)
2007	1,278	116	77	196	7	-42	32
2008	1,277	116	281	252	20	6	120
2009	1,281	116	199	225	13	-8	85
2010	1,238	116	361	276	30	14	157
2011	1,230	116	430	297	49	13	186
2012	1,262	116	203	236	14	-16	84
2013	1,282	116	148	208	10	-16	62
2014	1,315	116	112	192	4	-17	48
100-year							
Average	1,243	116	317	261	35	-1	138
Maximum	1,315	116	727	344	138	74	327
Minimum	1,178	116	77	190	4	-60	32
Variance	851	0	21,680	1,236	765	594	4,409

Water year	Potential evapotranspiration (ha-m)	Urban irrigation (ha-m)	Precipitation (ha-m)	Actual evapotranspiration (ha-m)	Direct recharge (ha-m)	Storage change (ha-m)	Surface-water discharge (ha-m)	Potential mountain-front recharge (ha-m)	Total potential recharge (ha-m)
1915	44,919	4,360	17,496	11,327	2,609	344	7,577	623	3,232
1916	44,820	4,360	19,291	11,138	3,491	436	8,586	858	4,350
1917	44,402	4,360	13,096	10,493	1,983	-582	5,562	396	2,379
1918	45,878	4,360	11,674	9,827	1,356	-81	4,931	263	1,619
1919	45,433	4,360	8,665	8,929	763	-258	3,591	24	787
1920	45,597	4,360	10,688	10,159	1,221	-754	4,421	73	1,294
1921	44,877	4,360	13,174	10,409	1,111	312	5,702	64	1,175
1922	45,785	4,360	17,096	11,145	2,690	228	7,394	588	3,278
1923	45,560	4,360	10,210	9,660	1,078	-421	4,254	134	1,211
1924	46,391	4,360	6,936	8,644	502	-742	2,893	13	515
1925	45,905	4,360	7,118	8,596	404	-456	2,934	9	413
1926	46,636	4,360	11,969	10,077	1,004	128	5,121	40	1,044
1927	45,835	4,360	13,438	10,162	1,493	284	5,858	201	1,695
1928	46,544	4,360	9,361	9,287	798	-347	3,984	91	889

Table 3-3. West Coast Basin.—Continued

[ha-m, hectare-meter; mm, millimeter]

Water year	Potential evapotranspiration (ha-m)	Urban irrigation (ha-m)	Precipitation (ha-m)	Actual evapotranspiration (ha-m)	Direct recharge (ha-m)	Storage change (ha-m)	Surface-water discharge (ha-m)	Potential mountain-front recharge (ha-m)	Total potential recharge (ha-m)
1929	46,345	4,360	9,028	9,116	656	-198	3,813	22	679
1930	46,920	4,360	10,435	9,500	850	-5	4,450	94	944
1931	47,999	4,360	10,280	9,615	801	-115	4,339	41	842
1932	45,516	4,360	14,316	10,120	2,026	427	6,104	406	2,432
1933	45,161	4,360	9,342	8,977	852	-120	3,993	91	943
1934	47,798	4,360	8,885	8,840	661	-324	4,069	15	676
1935	45,487	4,360	16,844	11,335	1,888	706	7,274	351	2,240
1936	46,681	4,360	9,649	9,357	1,007	-412	4,056	81	1,088
1937	45,364	4,360	18,782	11,420	2,586	829	8,307	449	3,035
1938	45,688	4,360	17,302	10,920	2,604	456	7,682	459	3,063
1939	46,102	4,360	14,890	9,650	1,218	1,160	7,223	165	1,382
1940	46,773	4,360	11,706	11,046	1,563	-1,522	4,979	159	1,722
1941	44,926	4,360	27,171	12,697	5,220	1,866	11,748	1,245	6,465
1942	45,714	4,360	9,845	10,214	1,158	-1,271	4,104	68	1,225
1943	46,583	4,360	14,561	10,680	1,740	-25	6,525	213	1,952
1944	45,699	4,360	15,653	10,614	2,295	216	6,889	406	2,701
1945	46,008	4,360	11,765	10,080	1,387	-401	5,058	160	1,547
1946	46,743	4,360	9,507	9,386	786	-490	4,184	31	817
1947	46,966	4,360	11,104	9,582	1,152	-209	4,938	126	1,278
1948	46,191	4,360	5,171	7,817	302	-745	2,157	5	307
1949	46,096	4,360	7,208	8,345	461	-218	2,980	26	487
1950	46,241	4,360	8,782	8,880	610	-111	3,762	61	671
1951	46,607	4,360	6,597	8,253	319	-364	2,749	10	328
1952	45,787	4,360	18,690	11,363	1,982	1,430	8,275	512	2,494
1953	46,323	4,360	8,246	9,032	789	-672	3,457	62	852
1954	47,002	4,360	10,058	9,450	787	-165	4,345	59	847
1955	46,272	4,360	9,140	9,130	625	-102	3,846	25	650
1956	46,483	4,360	12,102	9,859	839	74	5,690	56	895
1957	47,165	4,360	7,904	8,668	549	-281	3,329	19	568
1958	46,439	4,360	19,299	11,885	2,421	925	8,427	503	2,925
1959	49,208	4,360	5,544	8,140	412	-1,069	2,422	21	432

Table 3-3. West Coast Basin.—Continued

[ha-m, hectare-meter; mm, millimeter]

Water year	Potential evapotranspiration (ha-m)	Urban irrigation (ha-m)	Precipitation (ha-m)	Actual evapotranspiration (ha-m)	Direct recharge (ha-m)	Storage change (ha-m)	Surface-water discharge (ha-m)	Potential mountain-front recharge (ha-m)	Total potential recharge (ha-m)
1960	48,020	4,360	8,227	8,759	443	-97	3,482	45	489
1961	47,499	4,360	4,189	7,170	233	-613	1,758	3	236
1962	45,969	4,360	15,612	10,463	1,391	1,181	6,936	414	1,805
1963	46,508	4,360	9,943	9,528	459	-87	4,402	21	480
1964	46,829	4,360	5,939	8,061	423	-694	2,510	9	432
1965	45,937	4,360	10,627	9,545	768	192	4,482	51	819
1966	47,718	4,360	14,477	10,282	1,735	337	6,483	512	2,247
1967	46,698	4,360	15,009	10,868	1,251	605	6,644	155	1,406
1968	48,221	4,360	11,168	9,866	1,091	-527	5,098	62	1,152
1969	46,538	4,360	20,513	11,498	2,850	1,200	9,324	779	3,629
1970	48,048	4,360	6,347	8,721	559	-1,238	2,665	29	587
1971	47,672	4,360	10,103	9,181	691	19	4,572	86	777
1972	48,408	4,360	6,148	7,900	430	-537	2,715	25	455
1973	46,455	4,360	15,305	10,738	1,566	795	6,565	411	1,977
1974	47,418	4,360	11,526	9,815	1,113	-116	5,074	144	1,257
1975	46,143	4,360	11,175	9,745	881	17	4,893	53	935
1976	47,462	4,360	6,879	8,161	329	-165	2,915	8	337
1977	47,407	4,360	10,721	10,009	512	-138	4,698	17	530
1978	46,601	4,360	26,977	12,566	4,297	2,601	11,874	1,280	5,577
1979	47,104	4,360	16,070	11,482	2,523	-537	6,962	559	3,082
1980	46,946	4,360	20,889	11,798	3,422	658	9,372	718	4,140
1981	48,856	4,360	7,847	9,590	745	-1,457	3,329	46	791
1982	46,785	4,360	11,441	10,120	899	-75	4,857	66	965
1983	45,888	4,360	25,417	12,780	3,560	2,286	11,152	829	4,388
1984	49,264	4,360	7,955	10,044	1,201	-2,276	3,345	96	1,297
1985	47,429	4,360	8,992	9,247	739	-425	3,791	75	814
1986	47,068	4,360	17,832	11,267	1,848	1,227	7,850	464	2,312
1987	47,902	4,360	5,046	8,432	461	-1,591	2,104	18	478
1988	47,740	4,360	10,136	9,609	664	-83	4,306	90	754
1989	47,810	4,360	7,183	8,465	551	-449	2,976	42	593
1990	48,591	4,360	5,625	7,863	218	-533	2,435	4	223

**Table 3-3.** West Coast Basin.—Continued

[ha-m, hectare-meter; mm, millimeter]

Water year	Potential evapotranspiration (ha-m)	Urban irrigation (ha-m)	Precipitation (ha-m)	Actual evapotranspiration (ha-m)	Direct recharge (ha-m)	Storage change (ha-m)	Surface-water discharge (ha-m)	Potential mountain-front recharge (ha-m)	Total potential recharge (ha-m)
1991	47,059	4,360	9,819	9,145	545	189	4,302	102	647
1992	48,312	4,360	16,160	11,023	1,793	745	6,959	565	2,358
1993	47,176	4,360	23,500	12,275	3,490	1,673	10,423	960	4,451
1994	47,979	4,360	7,892	9,511	635	-1,227	3,332	31	666
1995	46,228	4,360	22,828	12,211	3,029	1,635	10,313	805	3,834
1996	48,395	4,360	9,200	9,791	1,005	-1,205	3,968	73	1,079
1997	48,656	4,360	12,627	10,124	1,665	-217	5,415	335	2,001
1998	45,697	4,360	27,253	12,963	4,362	2,324	11,964	1,098	5,460
1999	46,419	4,360	7,547	9,592	836	-1,663	3,143	40	876
2000	48,086	4,360	8,764	9,307	749	-645	3,713	61	809
2001	46,612	4,360	14,082	10,462	1,538	226	6,216	377	1,915
2002	47,586	4,360	3,630	7,331	325	-1,165	1,499	11	337
2003	47,512	4,360	11,963	10,098	615	287	5,323	58	673
2004	48,435	4,360	7,734	8,659	610	-474	3,299	35	645
2005	45,894	4,360	27,407	12,892	3,771	2,785	12,320	1,177	4,948
2006	47,472	4,360	9,609	10,245	854	-1,198	4,067	46	900
2007	48,167	4,360	2,885	7,380	274	-1,598	1,188	5	279
2008	48,130	4,360	10,613	9,505	749	210	4,508	226	975
2009	48,293	4,360	7,500	8,472	495	-310	3,204	34	529
2010	46,660	4,360	13,601	10,394	1,120	510	5,937	287	1,407
2011	46,375	4,360	16,205	11,193	1,865	478	7,028	359	2,225
2012	47,564	4,360	7,646	8,911	534	-599	3,160	24	558
2013	48,335	4,360	5,587	7,846	366	-585	2,321	10	376
2014	49,584	4,360	4,204	7,252	157	-653	1,808	2	159
100-year									
Average	46,844	4,360	11,936	9,840	1,303	-36	5,190	231	1,534
Maximum	49,584	4,360	27,407	12,963	5,220	2,785	12,320	1,280	6,465
Minimum	44,402	4,360	2,885	7,170	157	-2,276	1,188	2	159
Variance	1,209,565	0	30,816,057	1,756,462	1,086,787	844,446	6,266,687	93,312	1,795,142

**Table 3-4.** Orange County.

[ha-m, hectare-meter; mm, millimeter]

Water year	Potential evapotranspiration (mm)	Urban irrigation (mm)	Precipitation (mm)	Actual evapotranspiration (mm)	Direct recharge (mm)	Storage change (mm)	Surface-water discharge (mm)
1915	1,210	142	442	386	56	8	134
1916	1,216	142	483	383	75	14	154
1917	1,203	142	310	347	33	-22	93
1918	1,239	142	278	323	21	-8	84
1919	1,227	142	236	296	12	-1	71
1920	1,218	142	311	356	24	-19	93
1921	1,200	142	341	350	20	8	105
1922	1,225	142	465	386	64	14	143
1923	1,220	142	249	319	18	-20	74
1924	1,238	142	208	295	11	-18	62
1925	1,226	142	194	285	7	-14	58
1926	1,245	142	335	348	17	7	104
1927	1,228	142	386	358	34	14	122
1928	1,249	142	264	319	18	-11	80
1929	1,239	142	241	306	13	-7	73
1930	1,253	142	290	326	17	2	88
1931	1,282	142	269	319	14	-4	81
1932	1,223	142	385	351	45	14	117
1933	1,220	142	235	297	17	-9	71
1934	1,288	142	262	308	14	-6	88
1935	1,227	142	438	387	39	19	135
1936	1,263	142	244	309	18	-15	73
1937	1,225	142	521	400	62	35	166
1938	1,236	142	474	386	62	16	152
1939	1,245	142	400	343	31	20	148
1940	1,265	142	312	369	27	-38	96
1941	1,202	142	748	444	136	77	233
1942	1,235	142	259	355	23	-55	79
1943	1,254	142	422	377	42	5	141
1944	1,222	142	444	372	63	12	138



Table 3-4. Orange County.—Continued

[ha-m, hectare-meter; mm, millimeter]

Water year	Potential evapotranspiration (mm)	Urban irrigation (mm)	Precipitation (mm)	Actual evapotranspiration (mm)	Direct recharge (mm)	Storage change (mm)	Surface-water discharge (mm)
1945	1,233	142	315	348	31	-17	96
1946	1,256	142	260	320	16	-18	84
1947	1,258	142	296	327	25	-7	93
1948	1,236	142	167	275	8	-24	50
1949	1,234	142	183	275	7	-12	55
1950	1,242	142	231	297	10	-4	70
1951	1,249	142	183	275	6	-11	54
1952	1,230	142	531	402	40	57	174
1953	1,242	142	224	311	16	-28	67
1954	1,256	142	290	328	17	-3	90
1955	1,240	142	238	304	11	-7	72
1956	1,249	142	311	331	13	1	108
1957	1,261	142	201	284	8	-10	61
1958	1,234	142	521	413	51	37	162
1959	1,313	142	136	267	9	-40	42
1960	1,293	142	202	284	6	-7	61
1961	1,276	142	103	228	4	-18	31
1962	1,235	142	373	348	19	32	116
1963	1,247	142	234	301	6	-6	74
1964	1,254	142	170	270	6	-16	52
1965	1,232	142	264	312	10	4	80
1966	1,282	142	348	340	30	10	110
1967	1,249	142	406	374	25	20	129
1968	1,291	142	250	313	16	-17	79
1969	1,245	142	562	400	66	53	184
1970	1,286	142	187	307	12	-46	56
1971	1,273	142	247	303	11	-5	80
1972	1,292	142	157	258	7	-15	49
1973	1,240	142	401	366	29	25	123
1974	1,269	142	294	328	21	-5	92
1975	1,232	142	291	326	15	0	91

**Table 3-4. Orange County.—Continued**

[ha-m, hectare-meter; mm, millimeter]

Water year	Potential evapotranspiration (mm)	Urban irrigation (mm)	Precipitation (mm)	Actual evapotranspiration (mm)	Direct recharge (mm)	Storage change (mm)	Surface-water discharge (mm)
1976	1,266	142	213	284	8	-1	65
1977	1,271	142	237	313	7	-14	73
1978	1,246	142	710	433	95	101	224
1979	1,260	142	430	399	59	-20	133
1980	1,252	142	562	410	88	25	181
1981	1,310	142	198	324	14	-58	60
1982	1,248	142	314	346	16	-2	96
1983	1,231	142	662	440	81	73	209
1984	1,324	142	194	331	23	-77	58
1985	1,272	142	254	315	15	-11	77
1986	1,264	142	404	369	28	23	125
1987	1,284	142	145	276	9	-41	44
1988	1,278	142	261	318	9	-3	79
1989	1,286	142	201	284	9	-10	60
1990	1,302	142	176	271	4	-12	55
1991	1,268	142	272	312	9	6	86
1992	1,300	142	390	367	30	16	119
1993	1,267	142	625	426	79	63	200
1994	1,288	142	215	327	13	-48	64
1995	1,245	142	558	417	59	46	177
1996	1,306	142	252	331	20	-36	78
1997	1,312	142	318	338	32	-7	97
1998	1,232	142	695	449	92	77	218
1999	1,255	142	169	313	15	-67	50
2000	1,303	142	217	302	10	-19	65
2001	1,264	142	299	330	17	1	93
2002	1,287	142	91	229	6	-29	27
2003	1,284	142	332	348	9	13	104
2004	1,311	142	200	284	8	-12	61
2005	1,244	142	691	446	78	89	220
2006	1,287	142	235	340	13	-48	70

Table 3-4. Orange County.—Continued

[ha-m, hectare-meter; mm, millimeter]

Water year	Potential evapotranspiration (mm)	Urban irrigation (mm)	Precipitation (mm)	Actual evapotranspiration (mm)	Direct recharge (mm)	Storage change (mm)	Surface-water discharge (mm)		
2007	1,312	142	72	234	5	-47	21		
2008	1,304	142	250	304	8	5	75		
2009	1,312	142	207	283	7	-5	63		
2010	1,264	142	378	358	22	22	118		
2011	1,254	142	458	394	40	22	143		
2012	1,289	142	202	299	10	-25	60		
2013	1,310	142	144	256	6	-19	43		
2014	1,338	142	122	240	3	-16	37		
100-year									
Average	1,259	142	314	333	26	-1	98		
Maximum	1,338	142	748	449	136	101	233		
Minimum	1,200	142	72	228	3	-77	21		
Variance	934	0	21,214	2,525	632	992	2,227		
Water year	Potential evapotranspiration (ha-m)	Urban irrigation (ha-m)	Precipitation (ha-m)	Actual evapotranspiration (ha-m)	Direct recharge (ha-m)	Storage change (ha-m)	Surface-water discharge (ha-m)	Potential mountain-front recharge (ha-m)	Total potential recharge (ha-m)
1915	27,165	3,185	9,934	8,667	1,249	185	3,018	1,314	2,562
1916	27,308	3,185	10,852	8,591	1,678	316	3,452	1,737	3,415
1917	27,007	3,185	6,956	7,780	749	-483	2,096	422	1,171
1918	27,822	3,185	6,248	7,257	477	-186	1,885	642	1,119
1919	27,552	3,185	5,297	6,643	274	-20	1,585	71	344
1920	27,340	3,185	6,994	7,989	538	-435	2,087	399	936
1921	26,939	3,185	7,650	7,859	444	181	2,351	156	600
1922	27,513	3,185	10,438	8,661	1,439	305	3,219	2,041	3,480
1923	27,393	3,185	5,589	7,155	411	-458	1,667	158	569
1924	27,789	3,185	4,672	6,627	236	-398	1,392	71	307
1925	27,529	3,185	4,345	6,402	155	-319	1,292	39	194
1926	27,947	3,185	7,513	7,811	391	165	2,332	379	770
1927	27,562	3,185	8,672	8,027	771	313	2,746	1,200	1,971
1928	28,045	3,185	5,925	7,169	402	-252	1,792	182	583

**Table 3-4. Orange County.—Continued**

[ha-m, hectare-meter; mm, millimeter]

Water year	Potential evapotranspiration (ha-m)	Urban irrigation (ha-m)	Precipitation (ha-m)	Actual evapotranspiration (ha-m)	Direct recharge (ha-m)	Storage change (ha-m)	Surface-water discharge (ha-m)	Potential mountain-front recharge (ha-m)	Total potential recharge (ha-m)
1929	27,819	3,185	5,422	6,862	281	-165	1,629	93	374
1930	28,122	3,185	6,518	7,310	374	41	1,979	362	736
1931	28,783	3,185	6,034	7,165	325	-97	1,825	127	452
1932	27,456	3,185	8,642	7,870	1,015	310	2,631	1,362	2,378
1933	27,384	3,185	5,281	6,669	389	-196	1,605	418	807
1934	28,918	3,185	5,882	6,919	311	-141	1,978	395	706
1935	27,551	3,185	9,828	8,678	869	436	3,031	915	1,783
1936	28,368	3,185	5,480	6,936	407	-327	1,650	440	847
1937	27,501	3,185	11,690	8,986	1,390	776	3,724	2,089	3,479
1938	27,747	3,185	10,651	8,668	1,397	349	3,423	1,848	3,245
1939	27,948	3,185	8,971	7,693	689	448	3,326	810	1,499
1940	28,394	3,185	7,000	8,285	613	-858	2,145	438	1,051
1941	26,992	3,185	16,802	9,973	3,057	1,719	5,237	3,807	6,864
1942	27,724	3,185	5,819	7,974	512	-1,245	1,764	183	695
1943	28,163	3,185	9,477	8,458	936	102	3,167	1,161	2,097
1944	27,428	3,185	9,962	8,341	1,425	272	3,109	1,568	2,993
1945	27,680	3,185	7,075	7,808	687	-385	2,150	359	1,045
1946	28,203	3,185	5,841	7,192	350	-410	1,895	172	522
1947	28,251	3,185	6,644	7,336	571	-155	2,078	603	1,174
1948	27,747	3,185	3,741	6,173	174	-536	1,116	39	213
1949	27,699	3,185	4,114	6,172	167	-265	1,225	54	221
1950	27,875	3,185	5,195	6,671	215	-86	1,581	138	353
1951	28,049	3,185	4,101	6,182	124	-243	1,223	31	155
1952	27,614	3,185	11,930	9,029	902	1,274	3,910	1,573	2,475
1953	27,895	3,185	5,025	6,972	366	-632	1,505	174	540
1954	28,192	3,185	6,502	7,358	384	-73	2,018	429	813
1955	27,852	3,185	5,339	6,827	256	-166	1,609	76	332
1956	28,051	3,185	6,994	7,430	294	24	2,432	143	436
1957	28,302	3,185	4,506	6,378	188	-235	1,361	46	234
1958	27,705	3,185	11,702	9,268	1,150	825	3,644	1,613	2,763
1959	29,469	3,185	3,064	5,990	211	-900	947	65	277

Table 3-4. Orange County.—Continued

[ha-m, hectare-meter; mm, millimeter]

Water year	Potential evapotranspiration (ha-m)	Urban irrigation (ha-m)	Precipitation (ha-m)	Actual evapotranspiration (ha-m)	Direct recharge (ha-m)	Storage change (ha-m)	Surface-water discharge (ha-m)	Potential mountain-front recharge (ha-m)	Total potential recharge (ha-m)
1960	29,022	3,185	4,524	6,367	140	-160	1,363	72	212
1961	28,647	3,185	2,307	5,127	81	-407	692	17	98
1962	27,729	3,185	8,365	7,824	420	711	2,596	1,047	1,467
1963	28,002	3,185	5,250	6,764	139	-138	1,670	37	176
1964	28,159	3,185	3,813	6,067	132	-362	1,163	31	163
1965	27,662	3,185	5,927	7,007	216	100	1,789	177	393
1966	28,779	3,185	7,822	7,645	681	217	2,464	1,061	1,742
1967	28,044	3,185	9,122	8,406	559	449	2,894	859	1,418
1968	28,996	3,185	5,604	7,031	363	-386	1,782	172	535
1969	27,949	3,185	12,624	8,988	1,491	1,195	4,135	2,472	3,963
1970	28,863	3,185	4,201	6,888	271	-1,040	1,268	122	393
1971	28,580	3,185	5,554	6,799	256	-110	1,794	354	610
1972	29,008	3,185	3,527	5,800	163	-342	1,092	212	375
1973	27,836	3,185	9,001	8,222	645	562	2,757	1,107	1,752
1974	28,488	3,185	6,592	7,361	470	-111	2,056	537	1,008
1975	27,666	3,185	6,535	7,322	343	9	2,046	149	492
1976	28,427	3,185	4,791	6,371	171	-24	1,459	54	226
1977	28,534	3,185	5,330	7,023	152	-306	1,645	44	196
1978	27,987	3,185	15,951	9,712	2,138	2,261	5,025	3,454	5,592
1979	28,299	3,185	9,647	8,965	1,326	-447	2,988	1,525	2,852
1980	28,111	3,185	12,619	9,206	1,973	567	4,058	2,596	4,569
1981	29,411	3,185	4,446	7,271	320	-1,306	1,347	115	436
1982	28,030	3,185	7,053	7,765	362	-37	2,149	335	697
1983	27,643	3,185	14,855	9,885	1,827	1,644	4,684	2,382	4,209
1984	29,717	3,185	4,355	7,433	517	-1,722	1,313	173	690
1985	28,564	3,185	5,706	7,081	326	-236	1,721	388	714
1986	28,373	3,185	9,072	8,291	639	512	2,815	794	1,433
1987	28,826	3,185	3,264	6,193	204	-925	978	51	255
1988	28,699	3,185	5,870	7,143	208	-72	1,777	82	290
1989	28,873	3,185	4,512	6,367	213	-234	1,351	240	453



**Table 3-4. Orange County.—Continued**

[ha-m, hectare-meter; mm, millimeter]

Water year	Potential evapotranspiration (ha-m)	Urban irrigation (ha-m)	Precipitation (ha-m)	Actual evapotranspiration (ha-m)	Direct recharge (ha-m)	Storage change (ha-m)	Surface-water discharge (ha-m)	Potential mountain-front recharge (ha-m)	Total potential recharge (ha-m)
1990	29,230	3,185	3,960	6,074	97	-260	1,234	36	133
1991	28,469	3,185	6,100	7,005	213	140	1,928	456	669
1992	29,180	3,185	8,750	8,230	665	362	2,678	1,143	1,808
1993	28,453	3,185	14,039	9,561	1,767	1,409	4,486	2,917	4,684
1994	28,929	3,185	4,816	7,343	283	-1,072	1,447	86	369
1995	27,955	3,185	12,521	9,354	1,330	1,041	3,982	2,099	3,430
1996	29,315	3,185	5,654	7,435	460	-806	1,750	392	852
1997	29,459	3,185	7,136	7,593	714	-163	2,179	954	1,667
1998	27,655	3,185	15,604	10,085	2,077	1,734	4,894	2,739	4,816
1999	28,182	3,185	3,784	7,017	336	-1,512	1,128	97	432
2000	29,246	3,185	4,864	6,785	223	-422	1,464	305	529
2001	28,371	3,185	6,719	7,403	386	16	2,099	529	915
2002	28,894	3,185	2,053	5,151	127	-651	611	29	156
2003	28,821	3,185	7,463	7,824	202	283	2,340	333	535
2004	29,425	3,185	4,480	6,380	189	-263	1,360	113	302
2005	27,926	3,185	15,515	10,016	1,752	2,000	4,933	3,040	4,792
2006	28,907	3,185	5,269	7,645	298	-1,070	1,583	118	416
2007	29,447	3,185	1,621	5,253	118	-1,046	482	23	141
2008	29,285	3,185	5,614	6,833	172	105	1,690	351	523
2009	29,457	3,185	4,642	6,353	167	-110	1,418	211	378
2010	28,371	3,185	8,497	8,045	496	493	2,648	1,105	1,601
2011	28,146	3,185	10,276	8,853	901	492	3,216	1,300	2,201
2012	28,937	3,185	4,530	6,719	218	-569	1,347	63	282
2013	29,409	3,185	3,238	5,753	127	-421	964	41	168
2014	30,048	3,185	2,745	5,391	62	-357	834	15	77
100-year									
Average	28,262	3,185	7,044	7,466	594	-24	2,194	695	1,289
Maximum	30,048	3,185	16,802	10,085	3,057	2,261	5,237	3,807	6,864
Minimum	26,939	3,185	1,621	5,127	62	-1,722	482	15	77
Variance	470,779	0	10,694,196	1,273,105	318,489	500,154	1,122,903	743,738	1,998,623

Table 3-5. Whittier area.

[ha-m, hectare-meter; mm, millimeter]

Water year	Potential evapotranspiration (mm)	Urban irrigation (mm)	Precipitation (mm)	Actual evapotranspiration (mm)	Direct recharge (mm)	Storage change (mm)	Surface-water discharge (mm)
1915	1,231	184	456	417	73	4	147
1916	1,240	184	534	409	106	17	185
1917	1,224	184	352	401	49	-26	113
1918	1,263	184	327	376	37	-8	105
1919	1,255	184	263	352	18	-5	83
1920	1,246	184	341	411	36	-28	107
1921	1,226	184	351	393	25	4	114
1922	1,250	184	543	419	101	25	183
1923	1,242	184	288	381	26	-26	91
1924	1,265	184	214	345	14	-26	66
1925	1,250	184	220	342	11	-18	69
1926	1,265	184	394	408	31	8	132
1927	1,251	184	447	404	57	18	152
1928	1,275	184	280	371	22	-17	89
1929	1,264	184	277	364	18	-10	88
1930	1,280	184	296	367	22	-3	95
1931	1,305	184	296	372	20	-6	95
1932	1,247	184	432	388	66	20	142
1933	1,248	184	259	345	24	-11	85
1934	1,316	184	316	365	22	-6	119
1935	1,249	184	480	431	54	22	157
1936	1,288	184	282	364	27	-15	90
1937	1,248	184	570	427	94	40	193
1938	1,262	184	541	417	94	24	191
1939	1,269	184	435	388	41	15	175
1940	1,288	184	327	416	33	-44	106
1941	1,222	184	803	449	181	87	270
1942	1,256	184	279	405	29	-59	88
1943	1,277	184	489	416	66	12	179
1944	1,244	184	472	401	84	13	159
1945	1,255	184	336	398	38	-23	108

Table 3-5. Whittier area.—Continued

[ha-m, hectare-meter; mm, millimeter]

Water year	Potential evapotranspiration (mm)	Urban irrigation (mm)	Precipitation (mm)	Actual evapotranspiration (mm)	Direct recharge (mm)	Storage change (mm)	Surface-water discharge (mm)
1946	1,281	184	294	376	20	-21	104
1947	1,282	184	336	376	38	-7	113
1948	1,261	184	187	330	9	-27	59
1949	1,259	184	209	330	12	-15	66
1950	1,274	184	257	351	16	-9	84
1951	1,278	184	203	330	7	-14	63
1952	1,253	184	609	432	72	71	219
1953	1,267	184	247	368	21	-36	78
1954	1,284	184	320	381	24	-7	106
1955	1,267	184	266	357	16	-7	85
1956	1,277	184	342	378	18	0	130
1957	1,287	184	232	340	12	-11	75
1958	1,256	184	569	447	77	39	191
1959	1,339	184	158	323	9	-43	53
1960	1,320	184	221	335	8	-9	71
1961	1,303	184	121	284	4	-22	38
1962	1,261	184	462	393	46	47	160
1963	1,269	184	264	362	8	-11	90
1964	1,280	184	188	324	9	-22	61
1965	1,254	184	311	371	19	5	99
1966	1,305	184	402	384	52	11	139
1967	1,269	184	470	428	41	25	161
1968	1,314	184	283	370	22	-21	97
1969	1,269	184	634	419	104	66	230
1970	1,310	184	211	368	16	-56	67
1971	1,296	184	283	355	17	-6	100
1972	1,317	184	173	312	9	-21	58
1973	1,263	184	471	415	51	32	157
1974	1,296	184	348	386	32	-5	119
1975	1,257	184	308	372	19	-2	103
1976	1,287	184	243	330	8	8	81

Table 3-5. Whittier area.—Continued

[ha-m, hectare-meter; mm, millimeter]

Water year	Potential evapotranspiration (mm)	Urban irrigation (mm)	Precipitation (mm)	Actual evapotranspiration (mm)	Direct recharge (mm)	Storage change (mm)	Surface-water discharge (mm)
1977	1,295	184	264	373	9	-24	90
1978	1,272	184	812	441	150	120	285
1979	1,290	184	492	439	82	-13	168
1980	1,279	184	648	433	128	40	232
1981	1,335	184	213	385	18	-73	68
1982	1,275	184	339	402	21	-10	111
1983	1,257	184	748	469	113	89	261
1984	1,352	184	216	396	28	-93	69
1985	1,302	184	304	377	25	-12	98
1986	1,296	184	463	420	43	25	159
1987	1,315	184	146	326	9	-52	46
1988	1,308	184	284	371	12	-7	92
1989	1,316	184	231	341	16	-14	74
1990	1,330	184	188	320	5	-16	63
1991	1,296	184	312	364	17	7	108
1992	1,327	184	437	412	48	17	144
1993	1,298	184	720	441	119	85	258
1994	1,318	184	221	383	14	-61	69
1995	1,276	184	582	444	71	48	202
1996	1,335	184	287	387	27	-38	96
1997	1,344	184	311	374	34	-14	102
1998	1,254	184	749	460	127	90	257
1999	1,288	184	146	353	15	-82	45
2000	1,330	184	267	364	16	-15	86
2001	1,293	184	320	373	25	-2	107
2002	1,315	184	113	285	6	-30	35
2003	1,310	184	405	412	20	18	139
2004	1,336	184	234	343	15	-15	75
2005	1,272	184	755	460	115	99	266
2006	1,315	184	254	395	16	-54	81

Table 3-5. Whittier area.—Continued

[ha-m, hectare-meter; mm, millimeter]

Water year	Potential evapotranspiration (mm)	Urban irrigation (mm)	Precipitation (mm)	Actual evapotranspiration (mm)	Direct recharge (mm)	Storage change (mm)	Surface-water discharge (mm)		
2007	1,335	184	85	292	5	-55	27		
2008	1,333	184	256	346	11	1	81		
2009	1,340	184	220	330	9	-7	72		
2010	1,291	184	407	401	34	20	137		
2011	1,279	184	522	433	61	33	179		
2012	1,317	184	215	352	11	-30	67		
2013	1,339	184	145	300	6	-22	45		
2014	1,363	184	144	296	3	-16	47		
100-year									
Average	1,285	184	350	380	38	-2	118		
Maximum	1,363	184	812	469	181	120	285		
Minimum	1,222	184	85	284	3	-93	27		
Variance	1,017	0	26,606	1,700	1,330	1,427	3,471		
Water year	Potential evapotranspiration (ha-m)	Urban irrigation (ha-m)	Precipitation (ha-m)	Actual evapotranspiration (ha-m)	Direct recharge (ha-m)	Storage change (ha-m)	Surface-water discharge (ha-m)	Potential mountain-front recharge (ha-m)	Total potential recharge (ha-m)
1915	5,819	871	2,154	1,970	343	20	693	116	458
1916	5,863	871	2,523	1,936	500	83	876	192	692
1917	5,785	871	1,662	1,894	230	-122	532	33	263
1918	5,972	871	1,544	1,779	177	-39	498	85	262
1919	5,932	871	1,245	1,666	83	-25	392	2	85
1920	5,890	871	1,611	1,940	172	-134	503	9	181
1921	5,793	871	1,661	1,855	118	20	538	2	121
1922	5,910	871	2,568	1,978	476	120	864	242	718
1923	5,872	871	1,361	1,802	123	-123	429	5	128
1924	5,978	871	1,013	1,629	66	-125	314	0	66
1925	5,910	871	1,039	1,618	50	-83	324	0	50
1926	5,979	871	1,864	1,928	145	40	623	31	175
1927	5,912	871	2,111	1,908	267	86	720	117	385
1928	6,026	871	1,323	1,752	102	-82	422	3	105



Table 3-5. Whittier area.—Continued

[ha-m, hectare-meter; mm, millimeter]

Water year	Potential evapotranspiration (ha-m)	Urban irrigation (ha-m)	Precipitation (ha-m)	Actual evapotranspiration (ha-m)	Direct recharge (ha-m)	Storage change (ha-m)	Surface-water discharge (ha-m)	Potential mountain-front recharge (ha-m)	Total potential recharge (ha-m)
1929	5,974	871	1,308	1,722	87	-47	416	1	88
1930	6,050	871	1,400	1,735	104	-16	448	12	116
1931	6,167	871	1,401	1,757	95	-29	449	2	97
1932	5,893	871	2,043	1,834	314	93	673	140	454
1933	5,899	871	1,222	1,630	112	-51	402	43	155
1934	6,219	871	1,493	1,725	103	-28	563	43	146
1935	5,903	871	2,268	2,036	257	102	743	68	325
1936	6,090	871	1,331	1,720	128	-73	426	38	165
1937	5,901	871	2,696	2,018	446	190	913	214	660
1938	5,963	871	2,558	1,970	445	112	902	199	644
1939	5,999	871	2,054	1,833	191	73	827	75	266
1940	6,090	871	1,548	1,965	158	-207	503	27	185
1941	5,777	871	3,797	2,124	857	413	1,274	386	1,243
1942	5,938	871	1,317	1,915	136	-281	417	6	143
1943	6,038	871	2,312	1,968	311	56	847	139	449
1944	5,880	871	2,231	1,895	395	59	752	151	546
1945	5,933	871	1,590	1,880	178	-110	512	11	189
1946	6,056	871	1,389	1,775	94	-100	491	7	100
1947	6,058	871	1,588	1,778	178	-33	536	73	251
1948	5,961	871	882	1,560	43	-127	277	0	44
1949	5,951	871	988	1,561	59	-72	310	1	59
1950	6,020	871	1,215	1,658	74	-44	398	5	79
1951	6,041	871	958	1,562	35	-67	299	0	35
1952	5,921	871	2,880	2,042	342	334	1,033	215	557
1953	5,991	871	1,167	1,740	100	-170	368	7	107
1954	6,067	871	1,511	1,801	113	-35	503	23	136
1955	5,989	871	1,257	1,685	74	-33	402	1	75
1956	6,036	871	1,616	1,787	83	2	615	8	91
1957	6,082	871	1,098	1,609	56	-50	353	1	57
1958	5,938	871	2,690	2,112	362	182	904	143	506
1959	6,329	871	747	1,526	45	-203	249	2	47

Table 3-5. Whittier area.—Continued

[ha-m, hectare-meter; mm, millimeter]

Water year	Potential evapotranspiration (ha-m)	Urban irrigation (ha-m)	Precipitation (ha-m)	Actual evapotranspiration (ha-m)	Direct recharge (ha-m)	Storage change (ha-m)	Surface-water discharge (ha-m)	Potential mountain-front recharge (ha-m)	Total potential recharge (ha-m)
1960	6,241	871	1,045	1,582	37	-41	338	1	38
1961	6,158	871	571	1,344	20	-104	181	0	21
1962	5,962	871	2,185	1,860	216	224	757	182	398
1963	5,999	871	1,246	1,710	37	-54	424	2	39
1964	6,050	871	887	1,534	43	-105	286	0	44
1965	5,925	871	1,468	1,756	88	25	470	17	105
1966	6,171	871	1,901	1,816	247	51	657	148	396
1967	6,000	871	2,224	2,021	193	119	762	67	259
1968	6,211	871	1,337	1,748	103	-101	457	12	115
1969	6,000	871	2,998	1,981	490	310	1,089	289	778
1970	6,194	871	996	1,738	75	-265	319	4	78
1971	6,128	871	1,336	1,678	81	-26	474	35	116
1972	6,224	871	820	1,474	42	-99	274	13	55
1973	5,970	871	2,224	1,961	241	151	742	128	370
1974	6,128	871	1,645	1,826	152	-25	563	60	212
1975	5,942	871	1,454	1,758	89	-8	485	3	92
1976	6,082	871	1,149	1,559	40	37	384	0	40
1977	6,120	871	1,248	1,762	44	-114	427	0	44
1978	6,012	871	3,839	2,086	710	568	1,346	452	1,162
1979	6,097	871	2,328	2,076	389	-62	795	134	524
1980	6,045	871	3,063	2,047	604	187	1,095	313	917
1981	6,311	871	1,009	1,821	84	-347	321	5	89
1982	6,025	871	1,602	1,899	97	-49	525	3	100
1983	5,942	871	3,534	2,216	533	423	1,233	219	752
1984	6,391	871	1,021	1,873	131	-439	326	4	136
1985	6,155	871	1,437	1,781	117	-57	466	38	155
1986	6,126	871	2,187	1,986	201	118	753	86	287
1987	6,217	871	689	1,543	44	-247	219	1	46
1988	6,183	871	1,342	1,755	56	-34	436	0	57
1989	6,219	871	1,094	1,610	73	-67	348	18	92
1990	6,286	871	887	1,513	21	-73	296	0	21

Table 3-5. Whittier area.—Continued

[ha-m, hectare-meter; mm, millimeter]

Water year	Potential evapotranspiration (ha-m)	Urban irrigation (ha-m)	Precipitation (ha-m)	Actual evapotranspiration (ha-m)	Direct recharge (ha-m)	Storage change (ha-m)	Surface-water discharge (ha-m)	Potential mountain-front recharge (ha-m)	Total potential recharge (ha-m)
1991	6,126	871	1,476	1,722	81	32	511	56	138
1992	6,275	871	2,066	1,946	229	82	680	122	350
1993	6,133	871	3,402	2,085	564	403	1,221	360	924
1994	6,229	871	1,046	1,810	68	-289	328	3	71
1995	6,034	871	2,749	2,100	336	227	957	149	485
1996	6,309	871	1,358	1,831	127	-181	452	14	141
1997	6,354	871	1,472	1,768	159	-66	481	33	192
1998	5,929	871	3,542	2,175	598	427	1,213	307	906
1999	6,086	871	690	1,666	70	-389	214	3	74
2000	6,287	871	1,260	1,723	73	-71	406	18	91
2001	6,111	871	1,511	1,764	120	-11	508	49	169
2002	6,217	871	532	1,349	27	-140	167	0	28
2003	6,192	871	1,914	1,949	94	85	656	36	130
2004	6,316	871	1,108	1,623	71	-70	354	13	83
2005	6,012	871	3,570	2,174	543	467	1,257	318	861
2006	6,217	871	1,201	1,868	77	-254	381	3	80
2007	6,311	871	404	1,382	25	-258	125	0	25
2008	6,301	871	1,209	1,637	54	6	383	9	63
2009	6,335	871	1,039	1,562	42	-35	341	2	45
2010	6,101	871	1,925	1,894	162	94	646	100	262
2011	6,045	871	2,469	2,049	290	157	844	150	440
2012	6,226	871	1,016	1,663	51	-143	316	1	51
2013	6,329	871	687	1,419	30	-105	213	0	30
2014	6,444	871	683	1,397	13	-78	221	0	13
100-year									
Average	6,072	871	1,653	1,795	180	-7	557	69	249
Maximum	6,444	871	3,839	2,216	857	568	1,346	452	1,243
Minimum	5,777	871	404	1,344	13	-439	125	0	13
Variance	22,713	0	594,454	37,991	29,714	31,884	77,554	10,024	72,807

**Table 3-6.** Los Angeles Forebay.

[ha-m, hectare-meter; mm, millimeter]

Water year	Potential evapotranspiration (mm)	Urban irrigation (mm)	Precipitation (mm)	Actual evapotranspiration (mm)	Direct recharge (mm)	Storage change (mm)	Surface-water discharge (mm)
1915	1,235	104	439	254	50	-2	240
1916	1,228	104	536	258	68	9	304
1917	1,214	104	371	243	45	-15	201
1918	1,252	104	374	236	34	2	205
1919	1,249	104	249	210	17	-7	132
1920	1,237	104	312	237	30	-17	165
1921	1,219	104	369	240	26	7	199
1922	1,244	104	529	265	67	6	295
1923	1,240	104	274	224	22	-13	145
1924	1,268	104	174	196	11	-21	92
1925	1,246	104	213	205	9	-9	112
1926	1,266	104	438	253	27	12	249
1927	1,251	104	459	251	40	10	261
1928	1,274	104	257	216	18	-11	138
1929	1,261	104	311	225	20	-1	170
1930	1,280	104	302	222	22	-1	164
1931	1,310	104	320	229	21	-1	174
1932	1,248	104	438	242	49	7	242
1933	1,241	104	291	214	20	-4	164
1934	1,306	104	361	229	19	-3	220
1935	1,239	104	519	268	49	18	287
1936	1,273	104	309	227	29	-9	166
1937	1,239	104	569	270	68	18	316
1938	1,251	104	589	268	69	12	343
1939	1,265	104	448	236	30	19	268
1940	1,277	104	337	257	34	-33	182
1941	1,213	104	836	297	131	49	463
1942	1,240	104	287	243	29	-34	152
1943	1,263	104	505	263	50	3	292
1944	1,234	104	484	252	61	4	271
1945	1,244	104	316	232	31	-14	171

**Table 3-6.** Los Angeles Forebay.—Continued

[ha-m, hectare-meter; mm, millimeter]

Water year	Potential evapotranspiration (mm)	Urban irrigation (mm)	Precipitation (mm)	Actual evapotranspiration (mm)	Direct recharge (mm)	Storage change (mm)	Surface-water discharge (mm)
1946	1,266	104	302	227	19	-11	171
1947	1,270	104	334	229	29	-5	185
1948	1,254	104	179	195	9	-17	95
1949	1,254	104	204	196	13	-8	106
1950	1,262	104	259	211	14	-3	141
1951	1,268	104	191	195	9	-9	100
1952	1,244	104	649	279	53	48	371
1953	1,260	104	236	218	20	-24	125
1954	1,278	104	303	224	19	-4	166
1955	1,259	104	280	218	17	-1	149
1956	1,266	104	361	233	19	0	212
1957	1,283	104	255	212	15	-5	136
1958	1,256	104	567	276	61	20	313
1959	1,335	104	163	194	10	-28	91
1960	1,313	104	212	199	8	-5	113
1961	1,296	104	129	174	5	-15	68
1962	1,252	104	470	248	29	31	266
1963	1,260	104	251	214	9	-5	137
1964	1,271	104	182	193	10	-14	97
1965	1,242	104	339	230	21	10	182
1966	1,296	104	453	249	40	6	262
1967	1,268	104	517	269	36	21	295
1968	1,310	104	339	236	26	-14	195
1969	1,262	104	680	279	75	36	394
1970	1,307	104	206	218	16	-36	111
1971	1,295	104	303	221	17	-3	172
1972	1,320	104	178	189	9	-17	100
1973	1,260	104	488	257	41	25	268
1974	1,292	104	363	237	28	-3	205
1975	1,245	104	335	229	24	2	184
1976	1,272	104	240	202	11	1	130



Table 3-6. Los Angeles Forebay.—Continued

[ha-m, hectare-meter; mm, millimeter]

Water year	Potential evapotranspiration (mm)	Urban irrigation (mm)	Precipitation (mm)	Actual evapotranspiration (mm)	Direct recharge (mm)	Storage change (mm)	Surface-water discharge (mm)
1977	1,286	104	287	231	12	-11	159
1978	1,263	104	824	294	102	66	466
1979	1,273	104	473	269	63	-15	259
1980	1,280	104	677	286	89	18	388
1981	1,337	104	229	232	18	-41	123
1982	1,270	104	325	236	21	-3	174
1983	1,251	104	813	304	94	62	456
1984	1,349	104	209	238	28	-64	111
1985	1,301	104	289	225	20	-8	155
1986	1,290	104	488	258	39	23	271
1987	1,309	104	143	198	11	-38	75
1988	1,295	104	310	229	16	2	167
1989	1,305	104	224	204	16	-10	118
1990	1,325	104	186	193	6	-13	103
1991	1,286	104	305	219	12	5	172
1992	1,318	104	513	265	46	22	283
1993	1,287	104	722	291	82	42	410
1994	1,315	104	218	226	15	-35	115
1995	1,273	104	642	284	64	33	365
1996	1,324	104	299	236	25	-24	165
1997	1,331	104	343	233	37	-9	185
1998	1,242	104	794	301	97	57	444
1999	1,263	104	209	225	20	-42	109
2000	1,304	104	289	226	21	-11	156
2001	1,268	104	410	244	35	4	230
2002	1,296	104	115	178	9	-29	60
2003	1,292	104	416	250	16	13	241
2004	1,316	104	235	208	16	-12	127
2005	1,245	104	878	307	95	74	506
2006	1,294	104	302	250	24	-32	164
2007	1,316	104	88	184	8	-46	45

**Table 3-6.** Los Angeles Forebay.—Continued

[ha-m, hectare-meter; mm, millimeter]

Water year	Potential evapotranspiration (mm)	Urban irrigation (mm)	Precipitation (mm)	Actual evapotranspiration (mm)	Direct recharge (mm)	Storage change (mm)	Surface-water discharge (mm)		
2008	1,309	104	321	226	18	7	174		
2009	1,318	104	224	202	12	-8	121		
2010	1,277	104	401	246	27	12	220		
2011	1,262	104	487	261	45	12	271		
2012	1,295	104	217	209	12	-15	115		
2013	1,314	104	155	185	9	-15	81		
2014	1,345	104	143	178	4	-16	80		
100-year									
Average	1,276	104	364	234	32	-1	202		
Maximum	1,349	104	878	307	131	74	506		
Minimum	1,213	104	88	174	4	-64	45		
Variance	934	0	30,326	921	637	569	10,183		
Water year	Potential evapotranspiration (ha-m)	Urban irrigation (ha-m)	Precipitation (ha-m)	Actual evapotranspiration (ha-m)	Direct recharge (ha-m)	Storage change (ha-m)	Surface-water discharge (ha-m)	Potential mountain-front recharge (ha-m)	Total potential recharge (ha-m)
1915	16,747	1,404	5,959	3,445	681	-22	3,258	388	1,069
1916	16,660	1,404	7,263	3,497	928	116	4,126	563	1,492
1917	16,461	1,404	5,028	3,296	611	-204	2,728	257	868
1918	16,983	1,404	5,066	3,196	466	27	2,780	363	829
1919	16,935	1,404	3,383	2,850	237	-94	1,794	62	299
1920	16,773	1,404	4,234	3,215	411	-224	2,235	172	583
1921	16,534	1,404	5,006	3,249	356	100	2,705	104	460
1922	16,873	1,404	7,178	3,591	903	88	4,000	699	1,602
1923	16,812	1,404	3,719	3,037	304	-178	1,960	113	418
1924	17,202	1,404	2,360	2,659	145	-281	1,242	32	177
1925	16,893	1,404	2,889	2,776	127	-127	1,516	30	157
1926	17,170	1,404	5,933	3,437	367	160	3,374	244	611
1927	16,965	1,404	6,218	3,408	547	129	3,538	435	982
1928	17,273	1,404	3,482	2,934	238	-152	1,866	68	306
1929	17,096	1,404	4,222	3,056	271	-10	2,309	72	343

**Table 3-6. Los Angeles Forebay.—Continued**

[ha-m, hectare-meter; mm, millimeter]

Water year	Potential evapotranspiration (ha-m)	Urban irrigation (ha-m)	Precipitation (ha-m)	Actual evapotranspiration (ha-m)	Direct recharge (ha-m)	Storage change (ha-m)	Surface-water discharge (ha-m)	Potential mountain-front recharge (ha-m)	Total potential recharge (ha-m)
1930	17,363	1,404	4,097	3,004	294	-18	2,222	109	403
1931	17,760	1,404	4,340	3,110	290	-14	2,359	113	402
1932	16,931	1,404	5,934	3,282	668	100	3,288	472	1,140
1933	16,832	1,404	3,941	2,899	269	-53	2,229	206	476
1934	17,706	1,404	4,892	3,110	252	-46	2,980	197	449
1935	16,801	1,404	7,034	3,633	670	250	3,885	358	1,027
1936	17,265	1,404	4,191	3,072	394	-121	2,250	175	568
1937	16,805	1,404	7,711	3,656	926	243	4,290	619	1,545
1938	16,963	1,404	7,983	3,633	939	167	4,647	665	1,604
1939	17,158	1,404	6,081	3,196	403	258	3,628	260	663
1940	17,312	1,404	4,575	3,489	464	-447	2,474	186	650
1941	16,456	1,404	11,344	4,033	1,772	658	6,284	1,165	2,938
1942	16,819	1,404	3,886	3,302	388	-463	2,063	106	494
1943	17,134	1,404	6,847	3,569	676	40	3,967	485	1,161
1944	16,736	1,404	6,559	3,413	823	58	3,669	527	1,350
1945	16,872	1,404	4,285	3,145	422	-190	2,312	152	574
1946	17,172	1,404	4,101	3,082	259	-153	2,317	88	347
1947	17,217	1,404	4,531	3,105	387	-70	2,513	258	645
1948	17,012	1,404	2,423	2,644	121	-230	1,292	19	140
1949	17,012	1,404	2,766	2,664	171	-109	1,443	62	233
1950	17,116	1,404	3,512	2,859	191	-42	1,907	72	263
1951	17,200	1,404	2,595	2,650	117	-124	1,356	23	140
1952	16,868	1,404	8,795	3,789	726	649	5,035	706	1,431
1953	17,092	1,404	3,195	2,953	271	-323	1,698	108	379
1954	17,335	1,404	4,104	3,042	261	-53	2,258	118	378
1955	17,076	1,404	3,792	2,961	236	-20	2,018	66	302
1956	17,170	1,404	4,894	3,165	251	2	2,880	75	326
1957	17,393	1,404	3,453	2,869	208	-71	1,851	58	266
1958	17,030	1,404	7,684	3,742	824	276	4,246	528	1,352
1959	18,103	1,404	2,213	2,633	131	-375	1,229	37	168
1960	17,813	1,404	2,875	2,701	113	-74	1,537	37	150

**Table 3-6.** Los Angeles Forebay.—Continued

[ha-m, hectare-meter; mm, millimeter]

Water year	Potential evapotranspiration (ha-m)	Urban irrigation (ha-m)	Precipitation (ha-m)	Actual evapotranspiration (ha-m)	Direct recharge (ha-m)	Storage change (ha-m)	Surface-water discharge (ha-m)	Potential mountain-front recharge (ha-m)	Total potential recharge (ha-m)
1961	17,580	1,404	1,747	2,357	70	-202	925	7	78
1962	16,980	1,404	6,378	3,362	387	419	3,614	457	844
1963	17,084	1,404	3,410	2,901	123	-74	1,864	31	153
1964	17,234	1,404	2,467	2,617	131	-187	1,310	13	143
1965	16,840	1,404	4,600	3,118	282	142	2,462	116	398
1966	17,579	1,404	6,148	3,375	545	77	3,554	492	1,037
1967	17,196	1,404	7,012	3,644	486	281	4,006	341	827
1968	17,772	1,404	4,601	3,197	355	-192	2,645	155	509
1969	17,114	1,404	9,223	3,781	1,015	484	5,347	869	1,883
1970	17,729	1,404	2,787	2,958	211	-482	1,504	69	280
1971	17,567	1,404	4,104	2,991	224	-36	2,329	176	400
1972	17,899	1,404	2,414	2,561	124	-225	1,356	67	192
1973	17,092	1,404	6,613	3,486	559	336	3,636	444	1,002
1974	17,518	1,404	4,928	3,210	379	-41	2,784	244	622
1975	16,883	1,404	4,539	3,104	322	25	2,491	106	428
1976	17,256	1,404	3,257	2,745	143	11	1,761	40	183
1977	17,435	1,404	3,898	3,129	162	-148	2,159	29	191
1978	17,134	1,404	11,173	3,992	1,377	889	6,319	1,142	2,519
1979	17,258	1,404	6,412	3,643	861	-199	3,511	463	1,324
1980	17,359	1,404	9,186	3,873	1,213	238	5,267	877	2,090
1981	18,133	1,404	3,107	3,153	249	-560	1,670	77	326
1982	17,217	1,404	4,402	3,205	279	-41	2,362	119	398
1983	16,972	1,404	11,022	4,129	1,275	841	6,180	875	2,151
1984	18,296	1,404	2,836	3,226	384	-873	1,503	93	476
1985	17,641	1,404	3,920	3,056	266	-107	2,108	148	414
1986	17,493	1,404	6,619	3,505	531	313	3,673	331	863
1987	17,749	1,404	1,937	2,690	146	-513	1,019	24	169
1988	17,562	1,404	4,209	3,106	221	23	2,263	93	313
1989	17,692	1,404	3,039	2,767	211	-138	1,602	91	302
1990	17,965	1,404	2,519	2,623	78	-173	1,396	18	95
1991	17,447	1,404	4,134	2,968	164	75	2,331	191	355

Table 3-6. Los Angeles Forebay.—Continued

[ha-m, hectare-meter; mm, millimeter]

Water year	Potential evapotranspiration (ha-m)	Urban irrigation (ha-m)	Precipitation (ha-m)	Actual evapotranspiration (ha-m)	Direct recharge (ha-m)	Storage change (ha-m)	Surface-water discharge (ha-m)	Potential mountain-front recharge (ha-m)	Total potential recharge (ha-m)
1992	17,878	1,404	6,951	3,595	620	296	3,844	534	1,154
1993	17,457	1,404	9,785	3,947	1,116	565	5,561	971	2,087
1994	17,836	1,404	2,958	3,071	198	-472	1,565	50	249
1995	17,259	1,404	8,713	3,845	871	453	4,948	721	1,592
1996	17,957	1,404	4,055	3,196	345	-324	2,241	167	512
1997	18,056	1,404	4,649	3,161	497	-121	2,516	308	805
1998	16,844	1,404	10,770	4,077	1,309	769	6,019	950	2,259
1999	17,124	1,404	2,828	3,054	268	-571	1,479	59	327
2000	17,688	1,404	3,919	3,071	280	-148	2,119	165	445
2001	17,189	1,404	5,562	3,313	479	55	3,119	301	780
2002	17,582	1,404	1,558	2,420	117	-390	814	21	138
2003	17,517	1,404	5,648	3,395	211	173	3,273	162	373
2004	17,841	1,404	3,189	2,816	214	-161	1,725	75	289
2005	16,885	1,404	11,908	4,158	1,284	1,005	6,865	1,164	2,448
2006	17,546	1,404	4,097	3,390	323	-434	2,221	95	418
2007	17,850	1,404	1,188	2,499	104	-626	614	13	117
2008	17,757	1,404	4,348	3,061	245	91	2,356	249	495
2009	17,868	1,404	3,031	2,737	161	-102	1,640	79	240
2010	17,316	1,404	5,440	3,332	365	165	2,982	277	642
2011	17,111	1,404	6,600	3,544	613	169	3,677	383	996
2012	17,559	1,404	2,948	2,836	165	-207	1,558	27	192
2013	17,813	1,404	2,100	2,504	116	-209	1,094	27	143
2014	18,247	1,404	1,936	2,420	52	-214	1,082	11	63
100-year									
Average	17,298	1,404	4,934	3,180	432	-12	2,738	267	699
Maximum	18,296	1,404	11,908	4,158	1,772	1,005	6,865	1,165	2,938
Minimum	16,456	1,404	1,188	2,357	52	-873	614	7	63
Variance	171,779	0	5,577,363	169,314	117,161	104,701	1,872,699	81,982	388,057



Table 3-7. Hollywood.

[ha-m, hectare-meter; mm, millimeter]

Water year	Potential evapotranspiration (mm)	Urban irrigation (mm)	Precipitation (mm)	Actual evapotranspiration (mm)	Direct recharge (mm)	Storage change (mm)	Surface-water discharge (mm)
1915	1,206	134	506	330	74	3	234
1916	1,202	134	584	331	101	5	281
1917	1,187	134	409	316	54	-17	190
1918	1,230	134	430	310	49	4	201
1919	1,220	134	291	289	22	-19	133
1920	1,217	134	358	317	33	-21	163
1921	1,207	134	416	322	28	8	193
1922	1,233	134	597	342	93	16	281
1923	1,227	134	306	304	24	-27	139
1924	1,256	134	197	272	10	-41	90
1925	1,232	134	241	279	7	-21	110
1926	1,252	134	472	332	27	22	226
1927	1,238	134	512	329	48	24	245
1928	1,263	134	284	295	17	-24	130
1929	1,252	134	325	298	17	-8	152
1930	1,268	134	306	288	16	-5	141
1931	1,292	134	352	304	21	-2	163
1932	1,232	134	489	316	55	23	229
1933	1,229	134	314	284	21	-7	150
1934	1,294	134	408	310	22	-4	214
1935	1,226	134	545	346	49	27	257
1936	1,263	134	340	303	32	-15	155
1937	1,225	134	610	345	83	31	285
1938	1,239	134	637	343	96	22	311
1939	1,255	134	461	309	34	19	233
1940	1,267	134	378	340	37	-39	175
1941	1,203	134	923	375	179	72	431
1942	1,230	134	317	328	31	-52	144
1943	1,257	134	539	342	55	6	270
1944	1,227	134	528	327	77	8	251
1945	1,239	134	349	312	33	-23	161

Table 3-7. Hollywood.—Continued

[ha-m, hectare-meter; mm, millimeter]

Water year	Potential evapotranspiration (mm)	Urban irrigation (mm)	Precipitation (mm)	Actual evapotranspiration (mm)	Direct recharge (mm)	Storage change (mm)	Surface-water discharge (mm)
1946	1,258	134	321	304	19	-21	154
1947	1,261	134	365	304	31	-8	172
1948	1,242	134	188	265	8	-37	86
1949	1,240	134	222	265	8	-17	101
1950	1,250	134	265	276	10	-8	122
1951	1,259	134	203	256	5	-16	92
1952	1,230	134	712	355	53	92	347
1953	1,248	134	256	294	18	-39	117
1954	1,267	134	323	301	16	-11	152
1955	1,247	134	306	292	14	-6	140
1956	1,254	134	386	309	18	2	191
1957	1,269	134	296	286	14	-8	139
1958	1,245	134	607	354	63	37	287
1959	1,321	134	199	271	10	-42	94
1960	1,303	134	230	266	6	-13	106
1961	1,287	134	151	236	4	-24	69
1962	1,242	134	540	324	29	63	259
1963	1,249	134	270	293	7	-23	126
1964	1,268	134	207	262	7	-23	95
1965	1,236	134	351	300	16	8	161
1966	1,285	134	492	323	41	21	241
1967	1,254	134	538	347	34	31	260
1968	1,300	134	374	317	29	-19	181
1969	1,253	134	732	354	92	59	362
1970	1,297	134	223	299	14	-59	103
1971	1,281	134	345	298	14	-2	169
1972	1,303	134	192	258	8	-30	90
1973	1,246	134	515	331	38	40	241
1974	1,277	134	399	315	30	-2	190
1975	1,234	134	355	301	19	0	168
1976	1,271	134	233	265	8	-15	109

**Table 3-7. Hollywood.—Continued**

[ha-m, hectare-meter; mm, millimeter]

Water year	Potential evapotranspiration (mm)	Urban irrigation (mm)	Precipitation (mm)	Actual evapotranspiration (mm)	Direct recharge (mm)	Storage change (mm)	Surface-water discharge (mm)
1977	1,274	134	326	306	8	-11	157
1978	1,248	134	913	369	121	119	439
1979	1,266	134	495	351	69	-21	230
1980	1,260	134	764	364	135	31	369
1981	1,317	134	256	318	21	-66	117
1982	1,255	134	358	318	19	-10	166
1983	1,229	134	876	384	115	95	416
1984	1,335	134	228	323	32	-96	104
1985	1,283	134	282	297	13	-23	130
1986	1,269	134	536	339	39	41	251
1987	1,292	134	150	270	9	-63	69
1988	1,281	134	349	308	13	1	161
1989	1,291	134	241	272	12	-19	110
1990	1,308	134	202	255	4	-19	96
1991	1,273	134	319	286	8	7	152
1992	1,301	134	589	347	49	49	278
1993	1,268	134	825	373	115	79	392
1994	1,295	134	241	310	16	-60	110
1995	1,246	134	746	365	95	65	355
1996	1,302	134	322	319	29	-43	152
1997	1,315	134	384	318	44	-19	175
1998	1,220	134	877	379	129	90	413
1999	1,252	134	223	306	23	-72	101
2000	1,292	134	323	307	20	-18	149
2001	1,253	134	484	330	43	16	228
2002	1,285	134	129	255	9	-59	58
2003	1,287	134	442	331	11	16	218
2004	1,308	134	264	285	12	-22	123
2005	1,236	134	942	384	119	118	456
2006	1,284	134	341	338	25	-46	158
2007	1,307	134	91	258	8	-82	42

Table 3-7. Hollywood.—Continued

[ha-m, hectare-meter; mm, millimeter]

Water year	Potential evapotranspiration (mm)	Urban irrigation (mm)	Precipitation (mm)	Actual evapotranspiration (mm)	Direct recharge (mm)	Storage change (mm)	Surface-water discharge (mm)		
2008	1,305	134	338	299	11	6	156		
2009	1,312	134	235	268	7	-15	109		
2010	1,261	134	438	323	23	22	204		
2011	1,256	134	509	339	43	22	240		
2012	1,297	134	229	280	9	-30	105		
2013	1,308	134	167	245	5	-25	76		
2014	1,347	134	143	230	2	-24	69		
100-year									
Average	1,263	134	398	310	36	-2	188		
Maximum	1,347	134	942	384	179	119	456		
Minimum	1,187	134	91	230	2	-96	42		
Variance	1,014	0	36,936	1,158	1,246	1,623	8,693		
Water year	Potential evapotranspiration (ha-m)	Urban irrigation (ha-m)	Precipitation (ha-m)	Actual evapotranspiration (ha-m)	Direct recharge (ha-m)	Storage change (ha-m)	Surface-water discharge (ha-m)	Potential mountain-front recharge (ha-m)	Total potential recharge (ha-m)
1915	4,240	473	1,780	1,159	259	11	824	580	838
1916	4,229	473	2,053	1,163	356	18	989	676	1,032
1917	4,174	473	1,437	1,113	189	-60	668	399	588
1918	4,325	473	1,513	1,092	173	15	706	525	698
1919	4,289	473	1,024	1,018	77	-65	467	136	213
1920	4,280	473	1,258	1,116	115	-74	574	234	349
1921	4,246	473	1,464	1,133	97	28	679	200	296
1922	4,337	473	2,100	1,204	327	55	987	851	1,178
1923	4,314	473	1,076	1,068	86	-95	490	224	310
1924	4,416	473	692	958	35	-144	316	67	102
1925	4,331	473	848	982	25	-75	388	36	61
1926	4,403	473	1,661	1,168	96	76	793	323	419
1927	4,353	473	1,800	1,158	169	85	861	523	692
1928	4,443	473	997	1,036	58	-83	458	133	191
1929	4,403	473	1,141	1,049	59	-28	534	100	159

Table 3-7. Hollywood.—Continued

[ha-m, hectare-meter; mm, millimeter]

Water year	Potential evapotranspiration (ha-m)	Urban irrigation (ha-m)	Precipitation (ha-m)	Actual evapotranspiration (ha-m)	Direct recharge (ha-m)	Storage change (ha-m)	Surface-water discharge (ha-m)	Potential mountain-front recharge (ha-m)	Total potential recharge (ha-m)
1930	4,461	473	1,077	1,014	56	-18	497	186	242
1931	4,543	473	1,236	1,068	74	-6	573	206	280
1932	4,334	473	1,718	1,111	193	82	806	622	814
1933	4,322	473	1,104	999	74	-24	527	326	399
1934	4,551	473	1,434	1,090	78	-14	752	230	308
1935	4,311	473	1,918	1,217	174	96	904	463	636
1936	4,440	473	1,197	1,065	112	-51	543	278	391
1937	4,307	473	2,144	1,214	292	109	1,001	770	1,062
1938	4,359	473	2,241	1,206	336	76	1,095	752	1,089
1939	4,414	473	1,622	1,087	121	67	819	451	571
1940	4,455	473	1,330	1,194	132	-138	615	338	470
1941	4,232	473	3,246	1,319	630	255	1,515	1,377	2,008
1942	4,327	473	1,113	1,155	108	-184	507	260	368
1943	4,422	473	1,894	1,201	195	21	950	508	702
1944	4,317	473	1,856	1,149	269	27	883	656	925
1945	4,359	473	1,229	1,098	117	-82	568	266	383
1946	4,424	473	1,129	1,070	65	-74	540	185	251
1947	4,436	473	1,284	1,069	110	-27	604	405	515
1948	4,368	473	661	932	27	-129	303	61	88
1949	4,363	473	782	931	28	-60	355	84	112
1950	4,396	473	934	971	34	-29	430	110	144
1951	4,427	473	714	901	17	-56	325	33	51
1952	4,325	473	2,505	1,248	186	324	1,220	733	919
1953	4,389	473	900	1,034	64	-138	413	230	293
1954	4,456	473	1,136	1,058	55	-38	533	181	235
1955	4,387	473	1,076	1,027	49	-20	493	114	163
1956	4,411	473	1,356	1,087	62	7	673	117	180
1957	4,461	473	1,041	1,005	50	-29	487	143	193
1958	4,377	473	2,134	1,246	223	130	1,008	596	819
1959	4,645	473	699	951	36	-148	332	154	190
1960	4,582	473	810	936	21	-47	373	94	115



Table 3-7. Hollywood.—Continued

[ha-m, hectare-meter; mm, millimeter]

Water year	Potential evapotranspiration (ha-m)	Urban irrigation (ha-m)	Precipitation (ha-m)	Actual evapotranspiration (ha-m)	Direct recharge (ha-m)	Storage change (ha-m)	Surface-water discharge (ha-m)	Potential mountain-front recharge (ha-m)	Total potential recharge (ha-m)
1961	4,525	473	529	830	13	-84	243	37	50
1962	4,367	473	1,899	1,138	100	221	913	529	629
1963	4,392	473	948	1,030	26	-79	445	97	123
1964	4,459	473	727	923	23	-82	336	35	58
1965	4,348	473	1,233	1,055	55	29	566	169	224
1966	4,519	473	1,729	1,137	144	75	846	570	714
1967	4,408	473	1,893	1,221	121	110	913	408	529
1968	4,573	473	1,315	1,116	101	-66	637	296	396
1969	4,405	473	2,573	1,243	323	207	1,272	862	1,185
1970	4,560	473	784	1,053	51	-208	362	144	195
1971	4,505	473	1,213	1,050	49	-9	595	275	324
1972	4,584	473	675	908	27	-106	318	183	210
1973	4,382	473	1,812	1,166	133	140	846	519	652
1974	4,490	473	1,403	1,107	107	-6	668	371	478
1975	4,339	473	1,247	1,060	67	1	592	178	245
1976	4,470	473	818	931	29	-52	382	90	119
1977	4,479	473	1,147	1,077	27	-37	553	120	146
1978	4,389	473	3,212	1,297	427	418	1,543	1,203	1,629
1979	4,451	473	1,740	1,235	242	-74	810	618	861
1980	4,429	473	2,686	1,279	474	108	1,298	992	1,466
1981	4,631	473	901	1,120	73	-232	413	211	284
1982	4,413	473	1,260	1,118	67	-35	583	194	261
1983	4,321	473	3,081	1,350	406	335	1,462	954	1,360
1984	4,695	473	802	1,135	112	-339	367	206	318
1985	4,512	473	993	1,044	46	-82	457	193	239
1986	4,464	473	1,884	1,190	137	146	883	450	587
1987	4,543	473	529	950	32	-221	241	73	105
1988	4,505	473	1,228	1,085	45	3	568	175	220
1989	4,539	473	849	958	41	-67	389	147	188
1990	4,599	473	709	896	14	-68	339	39	53
1991	4,477	473	1,122	1,004	28	26	536	264	292

Table 3-7. Hollywood.—Continued

[ha-m, hectare-meter; mm, millimeter]

Water year	Potential evapotranspiration (ha-m)	Urban irrigation (ha-m)	Precipitation (ha-m)	Actual evapotranspiration (ha-m)	Direct recharge (ha-m)	Storage change (ha-m)	Surface-water discharge (ha-m)	Potential mountain-front recharge (ha-m)	Total potential recharge (ha-m)
1992	4,576	473	2,072	1,221	174	172	977	729	903
1993	4,460	473	2,901	1,312	405	277	1,380	1,154	1,560
1994	4,554	473	848	1,089	57	-213	387	154	211
1995	4,383	473	2,622	1,283	334	229	1,249	900	1,234
1996	4,580	473	1,132	1,122	101	-152	533	274	375
1997	4,625	473	1,351	1,118	156	-66	616	465	621
1998	4,291	473	3,085	1,333	455	316	1,452	1,068	1,524
1999	4,402	473	785	1,075	80	-252	355	149	229
2000	4,545	473	1,137	1,080	71	-65	524	270	340
2001	4,407	473	1,700	1,162	152	56	803	478	630
2002	4,519	473	453	896	32	-207	205	71	102
2003	4,527	473	1,553	1,166	39	56	765	153	192
2004	4,599	473	929	1,004	43	-78	432	144	187
2005	4,347	473	3,314	1,352	417	416	1,602	1,189	1,607
2006	4,514	473	1,199	1,189	89	-161	556	202	290
2007	4,598	473	320	907	27	-287	147	53	80
2008	4,591	473	1,188	1,053	38	23	547	308	346
2009	4,613	473	828	942	26	-53	385	96	122
2010	4,434	473	1,540	1,137	82	77	717	369	452
2011	4,418	473	1,791	1,193	150	77	843	442	592
2012	4,563	473	806	985	32	-107	369	64	96
2013	4,600	473	589	863	18	-88	268	28	47
2014	4,737	473	502	809	8	-84	242	35	42
100-year									
Average	4,440	473	1,399	1,091	126	-6	661	353	480
Maximum	4,737	473	3,314	1,352	630	418	1,602	1,377	2,008
Minimum	4,174	473	320	809	8	-339	147	28	42
Variance	12,537	0	456,827	14,326	15,414	20,070	107,515	93,825	182,175

Table 3-8. Santa Monica.

[ha-m, hectare-meter; mm, millimeter]

Water year	Potential evapotranspiration (mm)	Urban irrigation (mm)	Precipitation (mm)	Actual evapotranspiration (mm)	Direct recharge (mm)	Storage change (mm)	Surface-water discharge (mm)
1915	1,152	151	506	385	70	17	184
1916	1,138	151	561	383	107	14	208
1917	1,135	151	372	365	49	-22	132
1918	1,188	151	448	370	56	8	166
1919	1,164	151	291	341	25	-23	100
1920	1,191	151	331	368	32	-30	112
1921	1,191	151	412	382	29	8	144
1922	1,221	151	482	390	74	3	166
1923	1,205	151	286	347	23	-28	95
1924	1,232	151	182	304	9	-40	60
1925	1,209	151	217	308	7	-19	72
1926	1,229	151	413	381	25	14	144
1927	1,216	151	491	389	48	29	175
1928	1,243	151	261	338	16	-29	88
1929	1,236	151	299	339	15	-9	105
1930	1,251	151	272	322	15	-6	92
1931	1,279	151	329	349	19	-2	114
1932	1,214	151	421	363	44	20	145
1933	1,207	151	297	329	21	-7	105
1934	1,271	151	356	352	21	-4	138
1935	1,215	151	498	408	44	22	175
1936	1,239	151	325	351	28	-14	111
1937	1,207	151	573	410	74	38	202
1938	1,223	151	599	406	91	35	218
1939	1,244	151	420	365	31	8	167
1940	1,252	151	381	401	36	-39	134
1941	1,204	151	847	449	161	89	299
1942	1,217	151	314	391	31	-62	106
1943	1,247	151	416	387	39	-9	150
1944	1,216	151	468	383	62	10	163
1945	1,229	151	332	364	30	-25	114

**Table 3-8.** Santa Monica.—Continued

[ha-m, hectare-meter; mm, millimeter]

Water year	Potential evapotranspiration (mm)	Urban irrigation (mm)	Precipitation (mm)	Actual evapotranspiration (mm)	Direct recharge (mm)	Storage change (mm)	Surface-water discharge (mm)
1946	1,238	151	283	341	17	-22	99
1947	1,248	151	325	346	27	-10	114
1948	1,221	151	164	283	6	-30	55
1949	1,222	151	221	298	9	-9	74
1950	1,229	151	246	309	11	-7	83
1951	1,238	151	192	285	6	-11	64
1952	1,209	151	622	411	52	87	223
1953	1,227	151	252	343	19	-44	86
1954	1,251	151	302	344	16	-13	106
1955	1,229	151	282	330	13	-5	95
1956	1,232	151	374	362	20	4	140
1957	1,250	151	282	327	14	-7	99
1958	1,225	151	571	421	62	37	201
1959	1,297	151	188	304	10	-42	68
1960	1,272	151	234	304	7	-7	82
1961	1,255	151	154	263	5	-16	53
1962	1,211	151	536	384	38	67	197
1963	1,226	151	265	348	9	-32	93
1964	1,245	151	192	292	8	-22	66
1965	1,213	151	338	347	20	7	115
1966	1,260	151	430	371	40	15	155
1967	1,233	151	482	402	32	27	173
1968	1,275	151	420	388	36	-15	161
1969	1,231	151	659	416	89	62	244
1970	1,271	151	185	334	12	-71	62
1971	1,257	151	319	341	14	-2	117
1972	1,275	151	186	285	9	-22	66
1973	1,227	151	479	391	37	37	166
1974	1,252	151	375	366	31	-4	134
1975	1,219	151	327	347	17	-3	117
1976	1,263	151	161	274	6	-21	53

Table 3-8. Santa Monica.—Continued

[ha-m, hectare-meter; mm, millimeter]

Water year	Potential evapotranspiration (mm)	Urban irrigation (mm)	Precipitation (mm)	Actual evapotranspiration (mm)	Direct recharge (mm)	Storage change (mm)	Surface-water discharge (mm)
1977	1,258	151	304	336	6	-5	119
1978	1,232	151	867	433	123	149	314
1979	1,252	151	433	417	56	-37	148
1980	1,239	151	732	427	137	48	270
1981	1,295	151	227	370	18	-87	77
1982	1,247	151	277	352	13	-28	92
1983	1,223	151	743	447	84	104	260
1984	1,315	151	220	372	23	-99	76
1985	1,261	151	237	325	10	-26	79
1986	1,245	151	544	407	41	51	196
1987	1,269	151	138	297	8	-62	46
1988	1,262	151	281	334	10	-5	93
1989	1,268	151	220	300	10	-13	73
1990	1,286	151	188	280	4	-14	70
1991	1,251	151	270	315	8	4	94
1992	1,275	151	531	404	45	47	186
1993	1,245	151	766	439	110	91	276
1994	1,270	151	249	365	17	-69	87
1995	1,222	151	714	432	96	80	258
1996	1,272	151	303	377	28	-57	106
1997	1,291	151	402	381	51	-18	140
1998	1,205	151	869	455	134	119	312
1999	1,225	151	217	365	22	-91	72
2000	1,262	151	307	357	21	-25	106
2001	1,223	151	451	385	43	16	159
2002	1,255	151	116	279	8	-59	39
2003	1,259	151	409	383	14	12	152
2004	1,278	151	234	313	12	-21	82
2005	1,214	151	858	449	116	133	311
2006	1,259	151	291	388	20	-64	98
2007	1,281	151	80	277	6	-77	26



Table 3-8. Santa Monica.—Continued

[ha-m, hectare-meter; mm, millimeter]

Water year	Potential evapotranspiration (mm)	Urban irrigation (mm)	Precipitation (mm)	Actual evapotranspiration (mm)	Direct recharge (mm)	Storage change (mm)	Surface-water discharge (mm)	
2008	1,274	151	287	330	11	1	96	
2009	1,278	151	223	298	9	-10	77	
2010	1,235	151	396	372	21	16	138	
2011	1,225	151	461	392	39	19	162	
2012	1,261	151	189	297	8	-27	62	
2013	1,270	151	167	271	6	-14	55	
2014	1,314	151	127	247	3	-16	45	
100-year								
Average	1,240	151	368	356	34	-2	130	
Maximum	1,315	151	869	455	161	149	314	
Minimum	1,135	151	80	247	3	-99	26	
Variance	1,076	0	31,896	2,247	1,115	2,053	4,328	
Water year	Potential evapotranspiration (ha-m)	Urban irrigation (ha-m)	Precipitation (ha-m)	Actual evapotranspiration (ha-m)	Storage change (ha-m)	Surface-water discharge (ha-m)	Potential mountain-front recharge (ha-m)	Total potential recharge (ha-m)
1915	13,720	1,801	6,023	4,591	207	2,188	1,592	2,431
1916	13,558	1,801	6,683	4,562	172	2,480	1,802	3,071
1917	13,515	1,801	4,434	4,343	-257	1,568	1,153	1,735
1918	14,149	1,801	5,340	4,409	93	1,973	1,340	2,006
1919	13,868	1,801	3,463	4,063	-279	1,188	582	873
1920	14,189	1,801	3,943	4,381	-356	1,339	733	1,113
1921	14,184	1,801	4,907	4,553	96	1,719	762	1,102
1922	14,540	1,801	5,741	4,644	39	1,978	1,991	2,872
1923	14,355	1,801	3,408	4,136	-335	1,133	793	1,067
1924	14,670	1,801	2,169	3,619	-476	717	150	261
1925	14,405	1,801	2,583	3,673	-229	852	57	144
1926	14,641	1,801	4,918	4,540	168	1,709	855	1,156
1927	14,479	1,801	5,844	4,633	350	2,088	1,469	2,043
1928	14,809	1,801	3,107	4,020	-347	1,048	479	666
1929	14,717	1,801	3,559	4,038	-103	1,248	357	534

**Table 3-8. Santa Monica.—Continued**

[ha-m, hectare-meter; mm, millimeter]

Water year	Potential evapotranspiration (ha-m)	Urban irrigation (ha-m)	Precipitation (ha-m)	Actual evapotranspiration (ha-m)	Direct recharge (ha-m)	Storage change (ha-m)	Surface-water discharge (ha-m)	Potential mountain-front recharge (ha-m)	Total potential recharge (ha-m)
1930	14,898	1,801	3,236	3,840	176	-74	1,095	695	871
1931	15,232	1,801	3,917	4,155	225	-22	1,360	693	918
1932	14,458	1,801	5,008	4,327	523	235	1,724	1,690	2,213
1933	14,376	1,801	3,539	3,917	252	-82	1,253	967	1,218
1934	15,143	1,801	4,242	4,194	247	-44	1,645	603	851
1935	14,466	1,801	5,929	4,860	529	260	2,081	1,301	1,830
1936	14,752	1,801	3,872	4,176	336	-165	1,325	817	1,153
1937	14,377	1,801	6,819	4,883	876	456	2,406	2,058	2,933
1938	14,565	1,801	7,130	4,836	1,078	418	2,600	2,020	3,099
1939	14,811	1,801	5,001	4,350	367	96	1,989	1,281	1,648
1940	14,915	1,801	4,534	4,776	433	-465	1,592	1,052	1,485
1941	14,335	1,801	10,083	5,351	1,912	1,055	3,566	3,257	5,170
1942	14,499	1,801	3,743	4,652	375	-743	1,260	823	1,198
1943	14,852	1,801	4,960	4,611	464	-102	1,787	1,129	1,593
1944	14,487	1,801	5,572	4,568	740	121	1,945	1,762	2,502
1945	14,633	1,801	3,952	4,336	359	-298	1,356	954	1,313
1946	14,741	1,801	3,369	4,061	198	-268	1,180	630	828
1947	14,865	1,801	3,877	4,121	317	-113	1,353	1,082	1,399
1948	14,539	1,801	1,950	3,375	74	-352	655	130	203
1949	14,550	1,801	2,635	3,548	109	-105	885	328	437
1950	14,635	1,801	2,924	3,682	135	-79	988	495	630
1951	14,740	1,801	2,288	3,395	67	-134	761	91	158
1952	14,396	1,801	7,411	4,900	625	1,035	2,652	1,886	2,511
1953	14,609	1,801	3,006	4,085	229	-528	1,021	756	985
1954	14,898	1,801	3,598	4,095	191	-149	1,263	446	637
1955	14,638	1,801	3,353	3,933	158	-62	1,126	416	574
1956	14,679	1,801	4,457	4,308	233	50	1,668	437	670
1957	14,891	1,801	3,356	3,890	172	-82	1,177	505	677
1958	14,588	1,801	6,795	5,019	735	445	2,396	1,745	2,480
1959	15,449	1,801	2,238	3,623	117	-504	804	505	622
1960	15,152	1,801	2,791	3,616	89	-85	973	419	508

Table 3-8. Santa Monica.—Continued

[ha-m, hectare-meter; mm, millimeter]

Water year	Potential evapotranspiration (ha-m)	Urban irrigation (ha-m)	Precipitation (ha-m)	Actual evapotranspiration (ha-m)	Direct recharge (ha-m)	Storage change (ha-m)	Surface-water discharge (ha-m)	Potential mountain-front recharge (ha-m)	Total potential recharge (ha-m)
1961	14,942	1,801	1,829	3,131	58	-185	626	126	185
1962	14,424	1,801	6,378	4,573	458	799	2,349	1,581	2,039
1963	14,600	1,801	3,159	4,139	103	-384	1,103	358	461
1964	14,823	1,801	2,289	3,478	95	-264	782	120	215
1965	14,447	1,801	4,025	4,130	235	87	1,374	529	764
1966	15,006	1,801	5,116	4,420	471	180	1,847	1,524	1,995
1967	14,687	1,801	5,741	4,786	377	318	2,061	1,178	1,555
1968	15,187	1,801	4,997	4,621	433	-178	1,922	850	1,283
1969	14,660	1,801	7,849	4,950	1,056	736	2,909	2,004	3,060
1970	15,137	1,801	2,207	3,975	141	-844	736	467	608
1971	14,968	1,801	3,798	4,057	166	-19	1,395	793	960
1972	15,185	1,801	2,213	3,390	105	-267	787	567	672
1973	14,608	1,801	5,700	4,651	440	436	1,974	1,563	2,003
1974	14,907	1,801	4,466	4,359	365	-48	1,592	1,050	1,414
1975	14,521	1,801	3,892	4,131	205	-37	1,394	665	870
1976	15,046	1,801	1,922	3,269	74	-255	636	244	318
1977	14,983	1,801	3,616	3,997	66	-64	1,418	449	515
1978	14,672	1,801	10,327	5,159	1,461	1,773	3,736	3,051	4,511
1979	14,911	1,801	5,161	4,972	666	-443	1,767	1,658	2,323
1980	14,760	1,801	8,724	5,090	1,638	576	3,221	2,258	3,896
1981	15,424	1,801	2,699	4,407	211	-1,031	914	655	866
1982	14,851	1,801	3,304	4,198	153	-338	1,093	567	720
1983	14,562	1,801	8,853	5,323	1,000	1,237	3,094	2,629	3,630
1984	15,666	1,801	2,625	4,435	271	-1,184	904	695	965
1985	15,021	1,801	2,821	3,868	124	-314	944	536	660
1986	14,829	1,801	6,476	4,852	484	609	2,331	1,437	1,921
1987	15,115	1,801	1,638	3,542	97	-744	545	164	261
1988	15,036	1,801	3,346	3,982	118	-64	1,112	602	720
1989	15,096	1,801	2,616	3,575	118	-150	875	486	604
1990	15,318	1,801	2,241	3,334	43	-163	828	104	146
1991	14,897	1,801	3,219	3,750	97	50	1,123	701	798

Table 3-8. Santa Monica.—Continued

[ha-m, hectare-meter; mm, millimeter]

Water year	Potential evapotranspiration (ha-m)	Urban irrigation (ha-m)	Precipitation (ha-m)	Actual evapotranspiration (ha-m)	Direct recharge (ha-m)	Storage change (ha-m)	Surface-water discharge (ha-m)	Potential mountain-front recharge (ha-m)	Total potential recharge (ha-m)
1992	15,190	1,801	6,327	4,817	532	564	2,216	1,915	2,447
1993	14,831	1,801	9,121	5,234	1,311	1,089	3,289	2,908	4,218
1994	15,122	1,801	2,969	4,351	207	-825	1,038	434	641
1995	14,554	1,801	8,508	5,149	1,140	949	3,070	2,247	3,387
1996	15,145	1,801	3,612	4,494	337	-679	1,262	756	1,093
1997	15,371	1,801	4,791	4,534	607	-216	1,667	1,355	1,962
1998	14,357	1,801	10,344	5,421	1,600	1,412	3,713	2,630	4,230
1999	14,587	1,801	2,584	4,349	259	-1,085	862	389	648
2000	15,036	1,801	3,658	4,249	247	-297	1,261	698	945
2001	14,569	1,801	5,377	4,587	509	187	1,896	1,399	1,908
2002	14,948	1,801	1,382	3,328	96	-700	460	167	263
2003	15,001	1,801	4,873	4,559	162	139	1,814	453	615
2004	15,227	1,801	2,792	3,729	145	-254	973	382	527
2005	14,458	1,801	10,221	5,353	1,380	1,587	3,703	2,982	4,362
2006	15,000	1,801	3,469	4,623	236	-761	1,173	732	968
2007	15,256	1,801	959	3,295	68	-917	314	107	175
2008	15,176	1,801	3,419	3,928	130	14	1,149	991	1,121
2009	15,218	1,801	2,660	3,555	104	-118	921	407	510
2010	14,709	1,801	4,720	4,430	253	192	1,646	1,023	1,276
2011	14,591	1,801	5,491	4,665	463	230	1,934	1,014	1,477
2012	15,022	1,801	2,247	3,543	91	-326	741	122	212
2013	15,132	1,801	1,988	3,229	72	-170	659	137	209
2014	15,655	1,801	1,518	2,941	32	-193	540	131	163
100-year									
Average	14,764	1,801	4,380	4,246	406	-19	1,548	353	759
Maximum	15,666	1,801	10,344	5,421	1,912	1,773	3,736	1,377	5,170
Minimum	13,515	1,801	959	2,941	32	-1,184	314	28	144
Variance	152,703	0	4,524,535	318,691	158,171	291,205	613,891	93,825	1,275,258

**Table 3-9.** Los Angeles groundwater study area.

[ha-m, hectare-meter; mm, millimeter]

Water year	Potential evapotranspiration (mm)	Urban irrigation (mm)	Precipitation (mm)	Actual evapotranspiration (mm)	Direct recharge (mm)	Storage change (mm)	Surface-water discharge (mm)
1915	1,206	135	450	331	65	6	184
1916	1,205	135	519	329	91	13	221
1917	1,194	135	349	311	51	-19	142
1918	1,232	135	332	295	37	-2	136
1919	1,221	135	246	272	20	-8	97
1920	1,219	135	310	310	34	-22	121
1921	1,202	135	360	312	29	7	147
1922	1,227	135	492	334	78	11	204
1923	1,221	135	272	290	27	-17	107
1924	1,244	135	191	262	14	-24	74
1925	1,228	135	203	262	11	-14	80
1926	1,247	135	366	312	28	8	153
1927	1,230	135	409	314	45	13	172
1928	1,251	135	258	282	21	-14	103
1929	1,243	135	264	280	19	-6	107
1930	1,258	135	288	286	23	-1	116
1931	1,286	135	292	291	22	-4	118
1932	1,224	135	407	306	56	14	167
1933	1,218	135	263	271	23	-5	109
1934	1,286	135	292	281	20	-6	133
1935	1,223	135	469	339	51	20	193
1936	1,257	135	277	285	29	-12	111
1937	1,221	135	536	343	75	28	225
1938	1,232	135	517	333	78	18	223
1939	1,244	135	411	299	35	21	191
1940	1,260	135	326	329	39	-39	132
1941	1,202	135	775	375	150	64	320
1942	1,229	135	274	313	32	-45	109
1943	1,252	135	441	328	52	3	193
1944	1,223	135	449	320	68	8	188
1945	1,233	135	321	305	37	-16	130



Table 3-9. Los Angeles groundwater study area.—Continued

[ha-m, hectare-meter; mm, millimeter

Water year	Potential evapotranspiration (mm)	Urban irrigation (mm)	Precipitation (mm)	Actual evapotranspiration (mm)	Direct recharge (mm)	Storage change (mm)	Surface-water discharge (mm)
1946	1,254	135	274	288	21	-16	117
1947	1,258	135	314	291	32	-6	132
1948	1,237	135	162	247	9	-23	64
1949	1,235	135	198	253	13	-10	78
1950	1,242	135	245	269	16	-5	99
1951	1,250	135	184	250	9	-12	72
1952	1,228	135	562	345	56	53	242
1953	1,243	135	231	278	22	-26	91
1954	1,259	135	287	288	21	-6	118
1955	1,241	135	255	276	17	-5	102
1956	1,248	135	335	297	20	1	151
1957	1,262	135	229	265	15	-8	93
1958	1,238	135	541	355	66	30	225
1959	1,316	135	155	249	11	-35	65
1960	1,292	135	216	260	10	-6	87
1961	1,275	135	117	219	6	-19	47
1962	1,234	135	433	312	34	38	184
1963	1,246	135	255	281	10	-8	107
1964	1,255	135	173	247	10	-18	69
1965	1,229	135	299	288	20	6	120
1966	1,280	135	398	307	44	10	172
1967	1,250	135	441	332	35	21	188
1968	1,293	135	302	295	27	-16	132
1969	1,246	135	599	345	81	46	263
1970	1,288	135	187	274	16	-43	75
1971	1,276	135	278	278	17	-2	120
1972	1,296	135	168	240	10	-18	70
1973	1,243	135	436	323	42	26	180
1974	1,271	135	330	298	30	-3	139
1975	1,235	135	314	294	23	0	131
1976	1,268	135	206	252	10	-4	83

**Table 3-9.** Los Angeles groundwater study area.—Continued

[ha-m, hectare-meter; mm, millimeter

Water year	Potential evapotranspiration (mm)	Urban irrigation (mm)	Precipitation (mm)	Actual evapotranspiration (mm)	Direct recharge (mm)	Storage change (mm)	Surface-water discharge (mm)
1977	1,271	135	273	292	12	-11	115
1978	1,248	135	770	369	117	92	327
1979	1,263	135	445	346	68	-18	184
1980	1,258	135	614	354	102	27	266
1981	1,312	135	214	295	20	-52	86
1982	1,254	135	313	305	23	-6	126
1983	1,233	135	716	380	97	72	303
1984	1,325	135	211	303	31	-73	84
1985	1,275	135	262	284	21	-12	105
1986	1,265	135	466	332	43	30	196
1987	1,287	135	140	254	12	-46	55
1988	1,280	135	277	288	16	-3	112
1989	1,286	135	208	259	15	-13	82
1990	1,305	135	174	245	6	-14	73
1991	1,267	135	281	278	14	5	118
1992	1,299	135	444	328	46	22	184
1993	1,268	135	676	365	96	60	290
1994	1,290	135	219	293	17	-43	87
1995	1,246	135	616	361	78	48	265
1996	1,302	135	264	299	27	-36	109
1997	1,311	135	344	304	43	-8	140
1998	1,229	135	764	383	118	76	322
1999	1,250	135	194	288	22	-58	77
2000	1,295	135	249	283	19	-19	101
2001	1,256	135	359	305	34	3	152
2002	1,281	135	103	223	8	-35	40
2003	1,278	135	367	314	17	13	158
2004	1,303	135	216	263	15	-15	88
2005	1,236	135	763	381	101	87	329
2006	1,280	135	260	309	22	-41	106
2007	1,301	135	76	225	7	-51	30

Table 3-9. Los Angeles groundwater study area.—Continued

[ha-m, hectare-meter; mm, millimeter

Water year	Potential evapotranspiration (mm)	Urban irrigation (mm)	Precipitation (mm)	Actual evapotranspiration (mm)	Direct recharge (mm)	Storage change (mm)	Surface-water discharge (mm)	
2008	1,296	135	290	282	18	7	118	
2009	1,303	135	211	256	12	-9	86	
2010	1,258	135	377	312	28	16	156	
2011	1,247	135	463	337	49	18	193	
2012	1,282	135	205	268	13	-22	80	
2013	1,301	135	152	236	9	-18	60	
2014	1,332	135	126	223	4	-18	52	
100-year								
Average	1,258	135	336	297	35	-1	140	
Maximum	1,332	135	775	383	150	92	329	
Minimum	1,194	135	76	219	4	-73	30	
Variance	910	0	24,765	1,400	849	893	4,689	
Water year	Potential evapotranspiration (ha-m)	Urban irrigation (ha-m)	Precipitation (ha-m)	Actual evapotranspiration (ha-m)	Storage change (ha-m)	Surface-water discharge (ha-m)	Potential mountain-front recharge (ha-m)	Total potential recharge (ha-m)
1915	179,559	20,080	67,018	49,312	822	27,324	4,754	14,394
1916	179,411	20,080	77,317	48,984	1,927	32,950	6,049	19,584
1917	177,674	20,080	52,005	46,246	-2,797	21,118	2,741	10,259
1918	183,411	20,080	49,364	43,954	-278	20,211	3,324	8,881
1919	181,784	20,080	36,631	40,437	-1,159	14,424	891	3,900
1920	181,490	20,080	46,076	46,210	-3,210	18,045	1,671	6,781
1921	178,948	20,080	53,548	46,416	1,065	21,836	1,318	5,629
1922	182,685	20,080	73,252	49,746	1,685	30,355	6,685	18,232
1923	181,700	20,080	40,561	43,166	-2,581	15,996	1,461	5,520
1924	185,145	20,080	28,438	38,976	-3,538	11,064	341	2,357
1925	182,820	20,080	30,291	39,037	-2,112	11,838	179	1,787
1926	185,603	20,080	54,533	46,511	1,152	22,754	1,942	6,138
1927	183,031	20,080	60,875	46,737	1,913	25,651	4,103	10,757
1928	186,270	20,080	38,468	42,036	-2,037	15,394	978	4,133
1929	184,979	20,080	39,371	41,629	-931	15,975	662	3,439

**Table 3-9.** Los Angeles groundwater study area.—Continued

[ha-m, hectare-meter; mm, millimeter

Water year	Potential evapotranspiration (ha-m)	Urban irrigation (ha-m)	Precipitation (ha-m)	Actual evapotranspiration (ha-m)	Direct recharge (ha-m)	Storage change (ha-m)	Surface-water discharge (ha-m)	Potential mountain-front recharge (ha-m)	Total potential recharge (ha-m)
1930	187,272	20,080	42,843	42,512	3,361	-206	17,256	1,492	4,853
1931	191,413	20,080	43,417	43,256	3,241	-537	17,537	1,206	4,447
1932	182,241	20,080	60,638	45,561	8,297	2,066	24,794	4,863	13,160
1933	181,343	20,080	39,126	40,329	3,459	-786	16,204	2,112	5,571
1934	191,422	20,080	43,513	41,786	2,904	-926	19,828	1,541	4,445
1935	182,047	20,080	69,812	50,523	7,642	2,951	28,776	3,579	11,220
1936	187,135	20,080	41,295	42,366	4,247	-1,827	16,589	1,881	6,128
1937	181,782	20,080	79,849	51,050	11,238	4,207	33,433	6,441	17,679
1938	183,399	20,080	76,908	49,604	11,576	2,647	33,161	6,186	17,761
1939	185,163	20,080	61,252	44,438	5,281	3,195	28,418	3,129	8,411
1940	187,589	20,080	48,507	48,985	5,746	-5,784	19,640	2,250	7,995
1941	178,971	20,080	115,296	55,833	22,369	9,522	47,651	11,664	34,033
1942	182,899	20,080	40,759	46,593	4,723	-6,640	16,163	1,473	6,195
1943	186,311	20,080	65,642	48,765	7,720	488	28,749	3,807	11,527
1944	182,044	20,080	66,885	47,624	10,175	1,226	27,939	5,248	15,423
1945	183,548	20,080	47,717	45,361	5,573	-2,418	19,281	1,951	7,523
1946	186,695	20,080	40,784	42,812	3,132	-2,443	17,363	1,133	4,265
1947	187,240	20,080	46,712	43,354	4,777	-921	19,582	2,643	7,420
1948	184,170	20,080	24,153	36,697	1,396	-3,395	9,535	259	1,656
1949	183,763	20,080	29,534	37,610	1,908	-1,468	11,564	568	2,476
1950	184,834	20,080	36,455	40,074	2,348	-693	14,806	905	3,253
1951	186,111	20,080	27,458	37,283	1,288	-1,787	10,754	193	1,481
1952	182,803	20,080	83,599	51,419	8,318	7,955	35,986	5,886	14,203
1953	185,035	20,080	34,339	41,401	3,259	-3,828	13,587	1,367	4,626
1954	187,367	20,080	42,700	42,910	3,197	-849	17,522	1,296	4,493
1955	184,683	20,080	37,935	41,080	2,520	-702	15,118	715	3,235
1956	185,819	20,080	49,828	44,226	2,980	213	22,489	858	3,838
1957	187,846	20,080	34,144	39,485	2,182	-1,216	13,772	784	2,965
1958	184,341	20,080	80,604	52,812	9,863	4,490	33,519	5,327	15,191
1959	195,846	20,080	23,066	37,020	1,650	-5,165	9,641	792	2,442
1960	192,314	20,080	32,203	38,726	1,516	-906	12,947	677	2,193

**Table 3-9.** Los Angeles groundwater study area.—Continued

[ha-m, hectare-meter; mm, millimeter

Water year	Potential evapotranspiration (ha-m)	Urban irrigation (ha-m)	Precipitation (ha-m)	Actual evapotranspiration (ha-m)	Direct recharge (ha-m)	Storage change (ha-m)	Surface-water discharge (ha-m)	Potential mountain-front recharge (ha-m)	Total potential recharge (ha-m)
1961	189,861	20,080	17,473	32,544	843	-2,802	6,967	194	1,037
1962	183,626	20,080	64,405	46,438	5,056	5,613	27,378	4,386	9,442
1963	185,430	20,080	37,920	41,761	1,528	-1,153	15,863	554	2,081
1964	186,778	20,080	25,717	36,726	1,537	-2,751	10,286	215	1,752
1965	182,913	20,080	44,570	42,812	2,975	939	17,924	1,091	4,065
1966	190,504	20,080	59,318	45,710	6,596	1,512	25,579	4,488	11,084
1967	186,096	20,080	65,699	49,404	5,260	3,056	28,059	3,127	8,388
1968	192,441	20,080	44,954	43,897	4,010	-2,450	19,578	1,583	5,593
1969	185,473	20,080	89,224	51,315	12,104	6,784	39,100	7,596	19,701
1970	191,714	20,080	27,873	40,836	2,393	-6,416	11,140	851	3,244
1971	189,975	20,080	41,352	41,309	2,558	-326	17,891	1,767	4,325
1972	192,944	20,080	25,007	35,695	1,537	-2,637	10,491	1,085	2,622
1973	185,073	20,080	64,952	48,122	6,285	3,904	26,720	4,334	10,619
1974	189,250	20,080	49,112	44,421	4,536	-509	20,743	2,491	7,027
1975	183,797	20,080	46,723	43,716	3,454	69	19,564	1,179	4,632
1976	188,814	20,080	30,711	37,510	1,463	-578	12,395	444	1,907
1977	189,259	20,080	40,603	43,402	1,722	-1,578	17,136	667	2,389
1978	185,832	20,080	114,653	54,993	17,464	13,637	48,638	11,038	28,502
1979	188,057	20,080	66,283	51,441	10,156	-2,622	27,388	5,126	15,282
1980	187,194	20,080	91,436	52,685	15,243	3,945	39,643	8,073	23,316
1981	195,248	20,080	31,906	43,878	2,987	-7,749	12,870	1,126	4,113
1982	186,628	20,080	46,548	45,435	3,370	-889	18,712	1,313	4,683
1983	183,595	20,080	106,610	56,503	14,382	10,663	45,142	8,193	22,575
1984	197,249	20,080	31,364	45,155	4,552	-10,809	12,545	1,291	5,843
1985	189,809	20,080	39,031	42,203	3,061	-1,828	15,674	1,438	4,499
1986	188,372	20,080	69,298	49,347	6,437	4,460	29,134	3,676	10,113
1987	191,549	20,080	20,885	37,826	1,757	-6,864	8,245	336	2,093
1988	190,588	20,080	41,233	42,807	2,327	-511	16,690	1,062	3,389
1989	191,445	20,080	30,965	38,501	2,216	-1,892	12,220	1,053	3,270
1990	194,196	20,080	25,968	36,490	855	-2,127	10,829	204	1,059
1991	188,606	20,080	41,791	41,352	2,069	815	17,634	1,830	3,899



**Table 3-9.** Los Angeles groundwater study area.—Continued

[ha-m, hectare-meter; mm, millimeter

Water year	Potential evapotranspiration (ha-m)	Urban irrigation (ha-m)	Precipitation (ha-m)	Actual evapotranspiration (ha-m)	Direct recharge (ha-m)	Storage change (ha-m)	Surface-water discharge (ha-m)	Potential mountain-front recharge (ha-m)	Total potential recharge (ha-m)
1992	193,314	20,080	66,108	48,890	6,777	3,203	27,317	5,164	11,941
1993	188,680	20,080	100,604	54,394	14,287	8,885	43,117	9,655	23,942
1994	192,088	20,080	32,569	43,577	2,502	-6,403	12,972	769	3,271
1995	185,491	20,080	91,761	53,676	11,556	7,193	39,416	7,151	18,707
1996	193,803	20,080	39,357	44,495	3,995	-5,312	16,259	1,716	5,712
1997	195,088	20,080	51,218	45,211	6,457	-1,229	20,858	3,547	10,004
1998	182,887	20,080	113,683	57,071	17,497	11,293	47,903	9,180	26,677
1999	186,000	20,080	28,865	42,944	3,235	-8,629	11,394	751	3,986
2000	192,747	20,080	36,993	42,110	2,821	-2,861	15,002	1,553	4,374
2001	186,925	20,080	53,511	45,363	5,054	499	22,675	3,193	8,246
2002	190,702	20,080	15,272	33,258	1,235	-5,142	6,000	302	1,537
2003	190,271	20,080	54,690	46,748	2,555	1,904	23,562	1,285	3,840
2004	193,991	20,080	32,106	39,104	2,265	-2,251	13,067	781	3,046
2005	183,913	20,080	113,576	56,645	14,966	13,015	49,030	10,289	25,255
2006	190,532	20,080	38,752	46,019	3,207	-6,102	15,707	1,213	4,420
2007	193,726	20,080	11,300	33,484	1,067	-7,597	4,426	203	1,270
2008	192,946	20,080	43,165	42,006	2,622	1,020	17,597	2,186	4,807
2009	193,892	20,080	31,391	38,181	1,810	-1,282	12,761	844	2,654
2010	187,246	20,080	56,149	46,435	4,210	2,335	23,249	3,279	7,489
2011	185,675	20,080	68,990	50,237	7,355	2,725	28,753	3,806	11,161
2012	190,830	20,080	30,459	39,857	1,949	-3,217	11,950	310	2,259
2013	193,592	20,080	22,653	35,177	1,329	-2,631	8,857	248	1,577
2014	198,345	20,080	18,752	33,184	587	-2,667	7,728	195	782
100-year									
Average	187,230	20,080	50,002	44,232	5,226	-180	20,803	2,688	7,914
Maximum	198,345	20,080	115,296	57,071	22,369	13,637	49,030	11,664	34,033
Minimum	177,674	20,080	11,300	32,544	587	-10,809	4,426	179	782
Variance	20,152,868	0	548,739,585	31,016,021	18,806,845	19,794,632	103,902,499	7,197,694	48,597,379

Prepared by the Sacramento Publishing Service Center.

For more information concerning this report, contact:

Director  
U.S. Geological Survey  
California Water Science Center  
6000 J Street, Placer Hall  
Sacramento, CA 95819  
dc\_ca@usgs.gov

or visit our Web site at:  
<http://ca.water.usgs.gov>

